

Historic, Archive Document

Do not assume content reflects current scientific knowledge, policies, or practices.

Reserve
1
Ag84F

CORE LIST

ROOFING FARM BUILDINGS

U. S. DEPT. OF AGRICULTURE
NATIONAL AGRICULTURAL LIBRARY
RECEIVED

DEC 11

PROCH



Farmers' Bulletin No. 2170

U.S. DEPARTMENT OF AGRICULTURE

CONTENTS

	PAGE
Types of roofing.....	3
Rigid shingles.....	3
Asbestos-cement sheets.....	7
Bituminous roofing.....	7
Metal roofing.....	12
Canvas roofing.....	16
Special roofing materials.....	17
Selection.....	17
Roof slope.....	17
Weight.....	17
Cost.....	18
Fire resistance.....	19
Appearance.....	19
Location.....	19
Estimating roofing.....	19
Flashing.....	19
Painting.....	20
Valley flashing.....	21
Vertical flashing.....	21
Gutters and downspouts.....	23
Snow guards.....	24
Roof repair.....	25
Locating leaks.....	25
Shingles.....	26
Metal roofing.....	26
Flashing.....	26
New roofing over old.....	28

This bulletin supersedes Farmers' Bulletin 1751, "Roof Coverings for Farm Buildings and Their Repair."

Washington, D.C.

Issued November 1961
Slightly revised March 1973

For sale by the Superintendent of Documents, U.S. Government Printing Office
Washington, D.C. 20402 - Price 25 cents

Roofing Farm Buildings

Prepared by *Northeastern Region, Agricultural Research Service*¹

Many types of roofing are available for farm buildings—*asphalt or asbestos-cement shingles, roll roofing, galvanized steel, aluminum, wood shingles, slate, and others.* They vary in durability, fire resistance, insulating value, and other properties.

Make your selection carefully, whether you are covering a new building or reroofing an old one. Some important considerations are discussed on pages 17 to 19.

For maximum service and protection, install the roofing properly and keep it in good repair. Improper installation and poor maintenance can result in leaks or other trouble and shorten the life of the roofing.

TYPES OF ROOFING

Rigid Shingles

Various kinds of rigid shingles are available. Wood, slate, and asbestos cement are discussed here, because they are most common on farm buildings. Others include clay shingles and tiles, molded-asbestos tile, and different kinds of metal shingles.

Wood

Wood shingles, if of a durable species and properly laid, make a satisfactory, attractive, and well-insulated roof.

Different grades of shingles are on the market. The best ones are

edge grained and all heartwood No. 1 grade.

Shingles in all grades below No. 1 are flat grained or contain varying amounts of sapwood.

No. 1 grade southern cypress, redwood, and cedar shingles are the most decay resistant.

No. 1 grade shingles are recommended for permanent roofs—especially for dwelling roofs. The lower grades of shingles are not economical for permanent construction, but are suitable for temporary roofs and for sidewalls.

Wood shingles are made in lengths of 16, 18, and 24 inches. Ordinarily they come in random widths, 2½ to 14 inches. You can get shingles of uniform width—5 or 6 inches—but they are generally used for decorative effects on roof and sidewalls.

Following are installation details for wood shingles:

Deck.—In warm, humid climates, wood shingles are commonly nailed to slats to permit ventilation of the underside (fig. 1). A slat roof is light in weight and low in cost. The slats may be 1- by 4-inch strips, spaced, center to center, a distance equal to the length of shingle exposed to the weather.

In cold climates, the shingles are usually laid over tight sheathing covered with rosin-sized paper. Slats with insulation board under them are sometimes used.

¹ For further information please contact Merrill S. Timmins, Jr., architect, ARC-East, Beltsville, Md. 20705.



BN-12001-X

Figure 1.—Laying wood shingles over slats.

Method.—One-fourth pitch is the minimum slope recommended for wood shingles. If the slope is much less than one-fourth pitch, it will be hard to keep the roof watertight.

On roofs of one-fourth pitch or steeper, lay the shingles as follows to provide a three-ply roof:

<i>Shingle length (inches)</i>	<i>Length exposed to weather (inches)</i>
16-----	5
18-----	5½
24-----	7½

On roofs of less than one-fourth pitch, lay the shingles as follows to provide a four-ply roof:

<i>Shingle length (inches)</i>	<i>Length exposed to weather (inches)</i>
16-----	3¾
18-----	4¾
24-----	5¾

Low-grade flat-grained shingles should be laid with the “bark” side exposed (the side that was nearest the bark in the tree). They will

weather better and be less likely to turn up at the butt or to become waterlogged.

Split shingles over 8 inches in width; atmospheric changes can crack wide shingles.

Double the shingles at all eaves and extend them about an inch beyond the edge.

Space dry shingles ¼ inch apart, and green or wet ones ⅓ inch, to allow for swelling in damp weather.

Fasten each shingle with two nails, one on each side, 1 to 2 inches above the butt line of the next course and not more than ¾ inch from the edge. Never nail in the middle—the shingle may split. Use threepenny rust-resistant nails for 16- and 18-inch and fourpenny nails for 24-inch shingles. Joints should be broken at least 1½ inches and all nails should be covered.

Check the coursing as the work progresses. The shingle rows must

be kept parallel to the eaves to avoid uneven exposure of the last few courses.

Hips and ridges may be finished "Boston" style as shown in figure 2.

Flashing.—Painted sheet iron or "tin" is frequently used for flashing with wood shingles. However, more durable material, such as 26- or 24-gage galvanized metal of the highest quality or heavily coated IX flashing tin, is recommended. See page 19 for information on installing flashing.

Staining.—Stains rich in coal-tar creosote have much more preservative value than those containing little or no coal-tar creosote. However, shingles treated with such stains cannot be satisfactorily painted; the creosote will bleed through paint even after several years' exposure. Shingles treated with stains containing little or no coal-tar creosote can be painted after short exposure to the weather.

Dipping is the best method of staining a shingle. Dip the shingle to within 3 inches of the tapered end. Brush coats may be applied for additional protection after several years' exposure.

Slate

Slate shingles make an attractive, durable, and fire-resistant roof covering.

They are available in different grades and in various colors. The best slates have a metallic appearance, do not absorb water, and are very strong. B-grade slate has sufficient durability for farm buildings.

Commercial slates range in size from 6 by 10 to 14 by 24 inches. The more commonly used sizes are 8 by 16, 9 by 12, and 9 by 18 inches.

Some dark slates fade to a lighter gray on exposure. This change in color is not always uniform and the roof may become unattractive. Certain green slates may become buff or brown after a few months' exposure. This change is sometimes considered desirable and it has no effect on the quality of the slate.

Slates are very heavy roofing material—700 to 900 pounds per square—and require strong roof framing. (A square of roofing is the quantity necessary to cover 100 square feet of roof surface.)

Slate roofs are commonly installed by roofing contractors.

Asbestos Cement

Asbestos-cement shingles are made of asbestos fiber and portland cement. They are strong, durable, and fire resistant.

They are available in a wide variety of colors and surface textures (including their natural color, which is similar to that of portland cement).

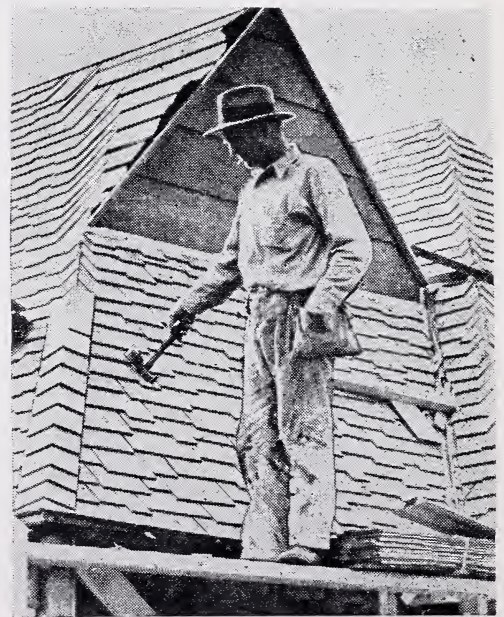
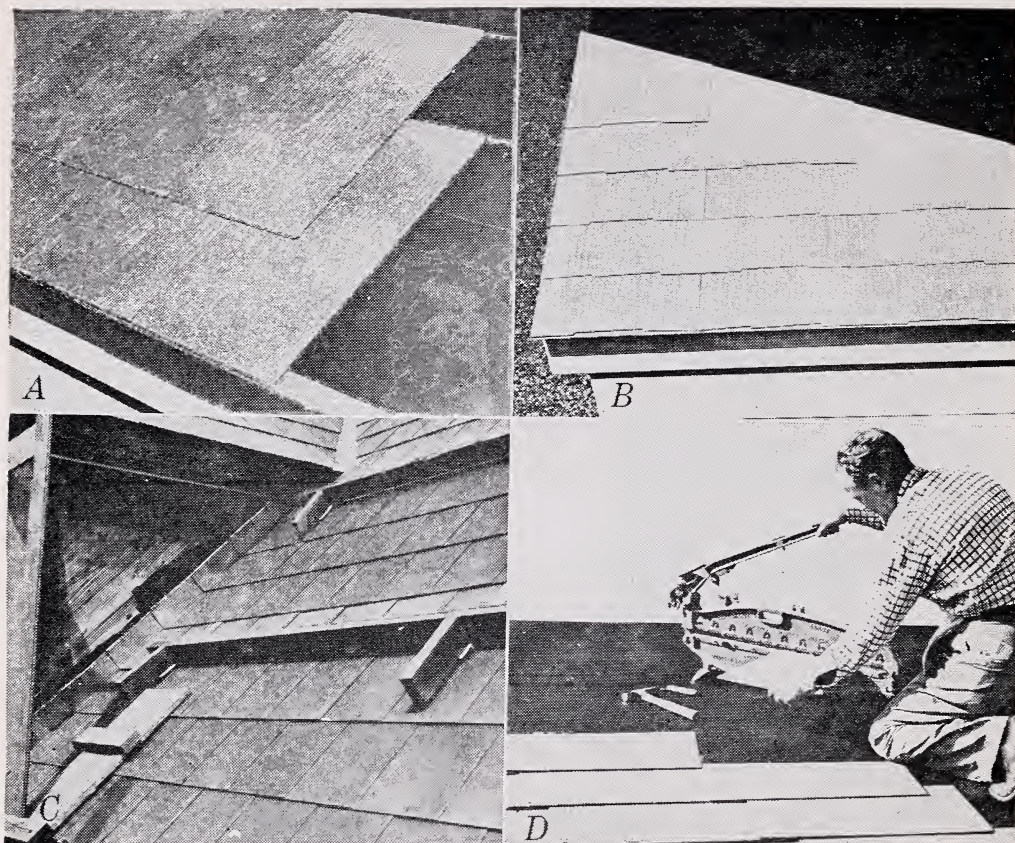

Figure 2.—Finishing hips and ridges "Boston" style.



BN-12002-X, BN-12000-X, BN-11999-X, BN-12003-X

Figure 3.—Asbestos-cement shingles: A, American-method individual; B, American multiple; C, side or Dutch lap; D, American ranch.

There is no standard by which to judge the merits of the many variations, and if you plan to use these shingles, select a type that has given good service in your locality.

Asbestos-cement shingles may be classed according to shape and method of application as follows:

- American - method individual shingles are 8 inches wide and 16 inches long (fig. 3, A). They are laid like wood shingles and weigh about 350 pounds per square.
- American multiple shingles usually come in strips 24 to 30 inches long and 12 to 15 inches high (fig. 3, B). They weigh about 300 pounds per square. When laid, they give the appearance of smaller individual shingles.

- Side-lap, or Dutch-lap, shingles are approximately 16 by 16 inches and weigh 265 to 290 pounds per square (fig. 3, C). They are laid with one-third or one-fourth side and top lap. One-third lap makes a tighter and more attractive roof. One-fourth lap makes a lighter-weight and lower-cost roof.

- American ranch shingles are 24 by 12 inches and weigh 250 to 260 pounds per square (fig. 3, D). They are usually laid with one-sixth side lap (20 inches exposed) and one-fourth top lap (9 inches exposed).

Detailed instructions for laying asbestos-cement shingles may be obtained from manufacturers or dealers.

Asbestos-Cement Sheets

Corrugated asbestos-cement sheets are available for covering roofs consisting of sheathing strips or purlins on top of rafters.

Dimensions of the sheets are: Width, 42 inches; length, 3 to 11 feet; thickness, $\frac{3}{8}$ inch or $\frac{1}{4}$ inch. The sheets are corrugated at 4.2-inch intervals.

Following are installation details:

Deck.—Sheets $\frac{3}{8}$ inch thick may be laid on purlins spaced 45 to 54 inches on center. Sheets $\frac{1}{4}$ inch thick may be laid on purlins spaced 30 to 42 inches on center. The exact spacing of the purlins required in each case will depend on expected snow loads.

Method.—The sheets should be laid with a side lap of 1 corrugation and a minimum end lap of 6 inches. Trim the corners of the sheets as shown in figure 4 to permit continuous lap.

Fasten the sheets to wood purlins with 3-inch ring-shank nails.

Fasten them to metal purlins with special fasteners available commercially.

Apply asphalt mastic on each side of the ridge. Set a gasket material on the mastic. Then cover the ridge with a semicircular ridge cap.

Bituminous Roofing

Bituminous roofing, in one of the many forms, is widely used on farm buildings.

Bituminous roofing materials divide into three general classes—lightweight felts, roll roofing, and asphalt shingles.

There are, however, four types of bituminous roof covering—the three listed above plus builtup roofing.

Bituminous roofing materials have a felt base. They are made of rag felt or asbestos felt. Asbestos-felt roofing is more fire resistant than the rag-felt roofing.

Lightweight Felts

Lightweight asphalt-saturated or tar-saturated felts are used (1) under shingles or other roofing ma-

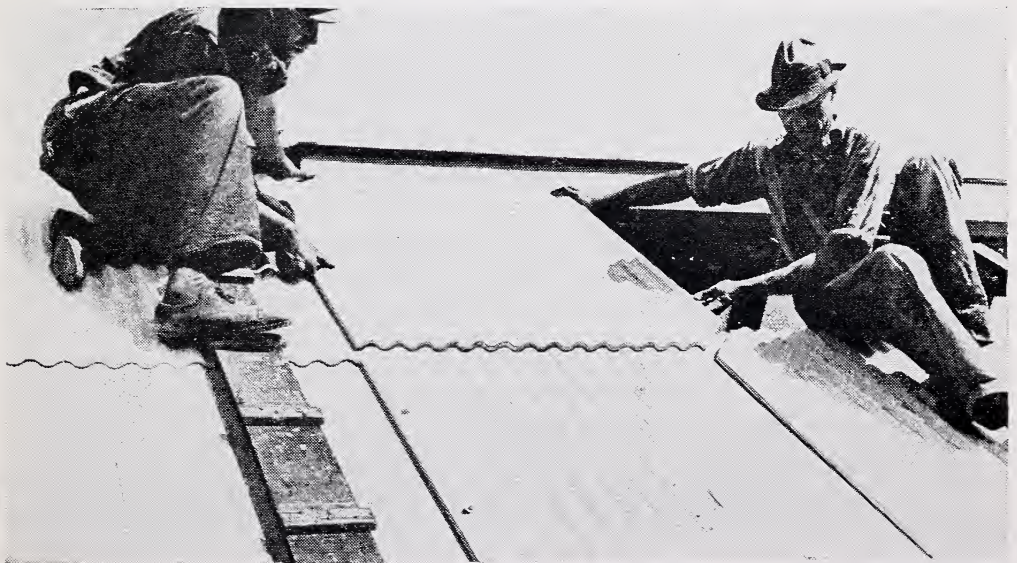

BN-12004-X

Figure 4.—Laying corrugated asbestos-cement sheets.

Table 1.—Lightweight felts—average size and weight of commercial packages

Material	Width	Area per roll	Weight per roll
	Inches	Square feet	Pounds
15-pound asphalt or tarred felt..	32 and 36	432	60
30-pound asphalt or tarred felt..	32 and 36	216	60
Slater's felt.....	36	500	32
Sheathing felt.....	36	500	35
Red rosin-sized sheathing paper..	36	500	20, 25, 30, and 40

materials, (2) for builtup roofing, and (3) to cover low-cost buildings such as sheds. They serve only as a very temporary roof covering, however, as they are easily torn by the wind.

Table 1 shows the several kinds of felts available and the average size and weight of commercial packages. Rosin-sized paper also is listed in the table. However, it is not felt material; it is merely a heavy building paper. It is used under steel roofing because acids in tar- or asphalt-saturated felts corrode the metal.

Roll Roofing

Roll roofing, of good quality and properly laid, is a suitable, low-first-cost covering for smaller farm buildings.

The roofing, which is also known as prepared, ready, and composition roofing, is composed of asphalt-saturated felt coated with asphalt. It is available in different grades or thicknesses. The heavier grades generally prove more satisfactory and give longer service.

Three forms of roll roofing are available:

- Mineral-surfaced roofing is coated with mineral granules (ce-

ramic-coated rock or crushed slate) on the weather side and dusted with talc or mica on the underside. It comes in a variety of colors—the color of the granules determining the color of the roofing.

- Smooth-surfaced roofing is not coated; both sides are dusted with talc or mica. It comes in one color only.

- Selvage-edge or wide-selvage roofing is coated with asphalt and mineral granules to 1 inch from the middle of the roll. The remainder is not coated with mineral granules, but there should be 2 or 3 inches of asphalt coating extending beyond the mineral granules for weather resistance where two strips of the roofing join. Because it provides two-ply coverage, selvage-edge roofing is more durable and more wind resistant than the other kinds of roll roofing and can be used on lower-pitched roofs. If you buy this roofing, be sure that it is made for use with cold cement and that the cement and the roofing are made by the same manufacturer.

Table 2 shows the average size and weight of commercial packages of roll roofing.

Following are installation details:

Table 2.—Roll roofing—average size and weight of commercial packages

Type	Width	Area per roll	Weight per roll
	Inches	Square feet	Pounds
Smooth surfaced.....	36	108	55 to 90
Selvage edge.....	36	108	70 to 74
Mineral surfaced.....	36	108	45 to 65

Deck.—Roll roofing — mineral surfaced, smooth surfaced, and selvage edge—should be laid on tight sheathing.

Method.—Roll roofing is usually laid with the sheets stretched parallel to the eaves (fig. 5). It can also be laid with the sheets stretched along the slope. If the latter method is used, fasten wood battens or metal strips over the long laps for more protection against tearing by the wind.

Mineral-surfaced roofing is laid as shown in figure 5. Lap the strips 2 or 3 inches at the side or edge. Lap the ends of adjoining strips 4

to 6 inches. Use large-headed galvanized nails to fasten the roofing. Space them 2 to 3 inches apart. If a nail goes into a crack between boards, pull it out and patch the hole in the roofing. Tin caps are not recommended. They corrode quickly and leave the nailhead protruding, which makes it easy for the wind to tear off the roofing.

Smooth-surfaced roofing may be laid in the same way as mineral-surfaced roofing, however, the “blind nailing” method is recommended. Increase the side lap to 4 inches and the end lap to 6 inches. Nail the underlying edges through tin or fiber disks on 6-inch center. Cement

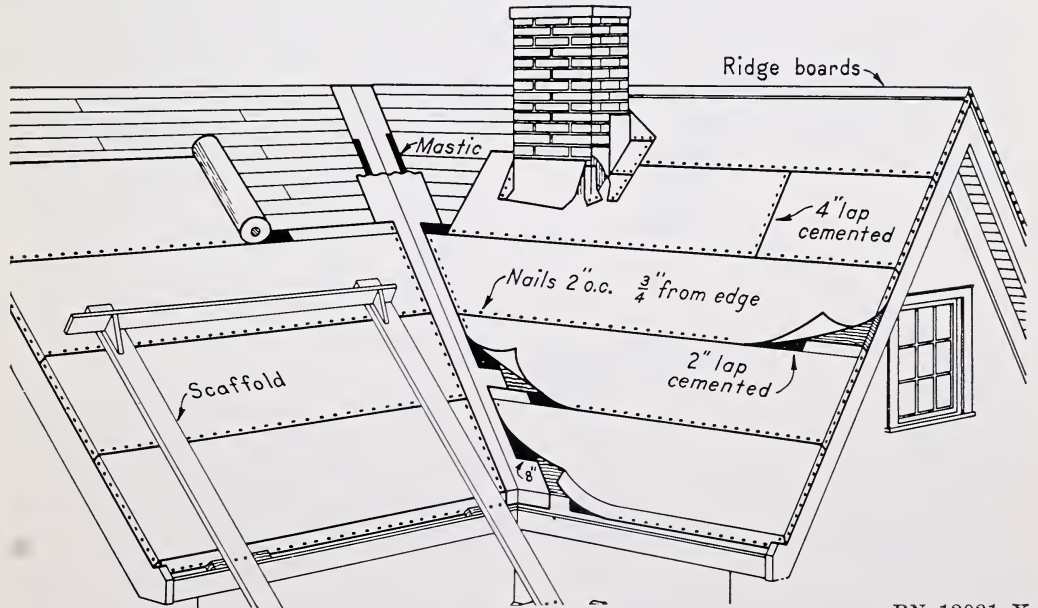

Figure 5.—Installation of regular roll roofing.

BN-12021-X

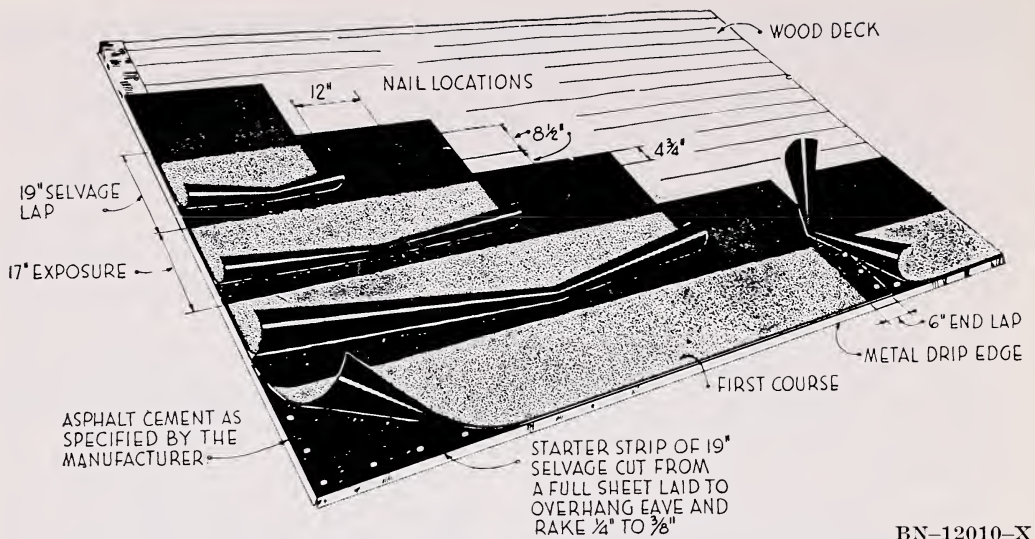

Figure 6.—Installation of selvage-edge roll roofing.

the overlying edges with hot asphalt or special blind-nailing cement. Step down firmly on these edges to make them stick.

Selvage-edge roofing is laid as shown in figure 6. Be sure that no gap is left between the coated parts of adjoining strips. Sunlight will deteriorate any exposed, unprotected part of the roofing.

Roll roofing is usually fastened at eaves and gables by nailing into the edge of the sheathing (fig. 5). Figure 7 shows a better method in which battens are used. Use barbed or cement-coated nails to fasten the battens.

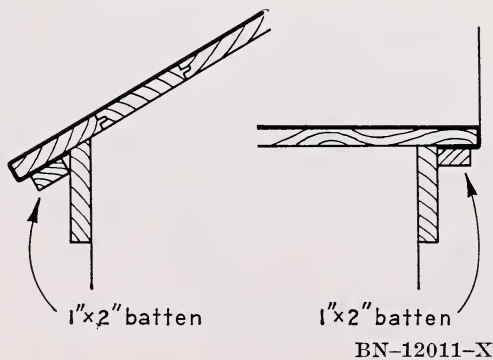

Figure 7.—Battens for fastening roll roofing at eaves.

Flashing.—Flashings should be of the same material as the roofing and in two thicknesses. Rust-resistant metal chimney flashing should be used at chimneys with all but the cheapest roofing. Chimney flashing should be wedged and calked into the mortar joints.

Asphalt Shingles

Asphalt shingles, also called composition shingles, are widely used for roof covering, because of their moderate cost, lightweight, and durability.

The shingles are composed of asphalt-saturated felt coated with asphalt and are surfaced with mineral granules on the weather side.

They are available as single shingles or in strips of several units, and in a wide variety of colors and patterns.

Asphalt shingles are semirigid and susceptible to damage by the wind. Also, cheap shingles, or shingles laid with too much surface exposed, may curl badly after weathering. Some asphalt shingles are made so that they can be locked down or interlocked when laid.

Strip shingles are available with a self-sealing compound on the tabs. Use one of these types in windy locations.

Strip shingles require less labor to apply than individual shingles. The three-tab strip shingle is one that is commonly used. It is 36 inches long and 12 inches high, and has cutouts 5 inches deep and $\frac{3}{8}$ inch wide. These cutouts produce the appearance of individual shingles.

Figure 8 shows the general method of laying asphalt shingles. Detailed directions normally are included with the shingles when purchased.

Builtup Roofing

Builtup roofing consists of several layers of lightweight felt, lapped

and cemented together with a bituminous material and covered with a layer of small-sized gravel or slag.

The roofing is long lived and low in cost. It has high fire resistance, although it will burn freely once ignited.

The roofing may be used on roofs sloping $\frac{1}{2}$ inch to 3 inches per foot. On greater slopes, it may slip in hot weather and the gravel may not stay in place. On lesser slopes, the uneven surface may prevent proper drainage.

Builtup roofs may be 3-, 4-, or 5-ply, according to the number of layers of felt. A 5-ply roof, if laid by skilled workmen in accordance with the manufacturer's specifications, should last 20 years or more. Builtup roofs are usually installed

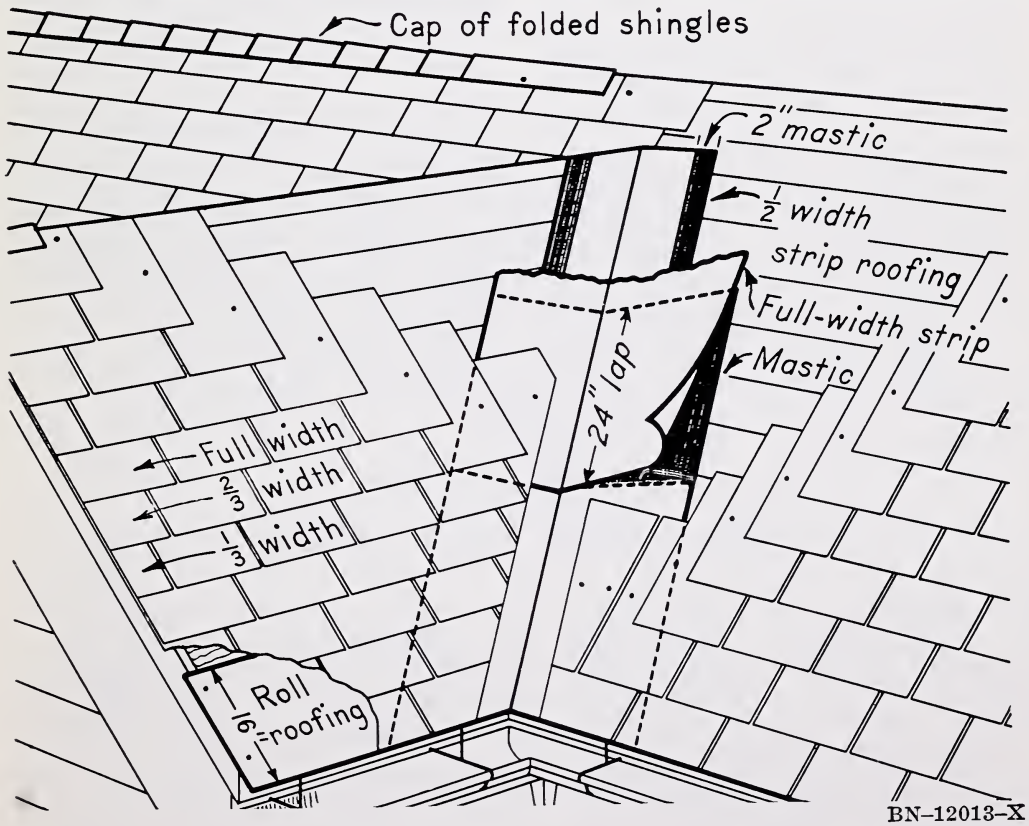

Figure 8.—Installation of ordinary asphalt shingles. In general, valley construction details apply to all types of shingles.

by contractors who have the necessary equipment and experience.

Metal Roofing

Metal roofings include tin, galvanized steel, aluminum, copper, and zinc. Copper and zinc are not used much on farm buildings, because of the high cost. They are laid like tin roofing.

Metal roofings are light in weight and fire resistant. Those laid with locked or soldered joints can be used on low-pitched roofs with little danger of leakage.

Metal roofings have little insulating value. Insulating materials may be needed under them. Proper grounding is required for protection against lightning.

Tin

The so-called tin roofing is actually soft steel or wrought iron coated with a mixture of lead and

tin. The material is more properly known as terne metal.

A tin roof of good material, properly laid and kept well painted, may last 40 to 50 years.

The roofing is available in strips 50 to 100 feet in length and 14, 20, 24, and 28 inches in width. These strips come in rolls for easy handling.

The roofing is made in two thicknesses, IC and IX; IX is the heavier. It is available with a lead-tin coating of 8, 20, or 40 pounds per 436 square feet. Durability of the roofing depends on the thickness of the coating rather than on the thickness of the metal.

Special sheet-metal tools are required to lay tin roofing. If you are not experienced in laying the roofing, it may be advisable to have professional roofers do the work.

Following are installation details:

Deck.—Tin roofing should be laid

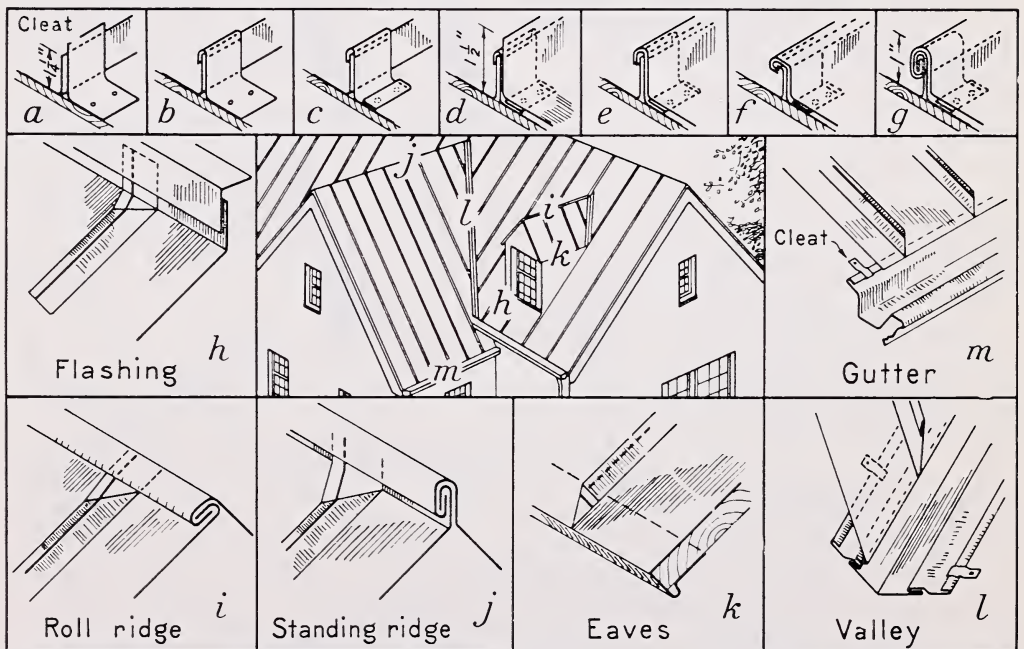

BN-12014-X

Figure 9.—Installation of tin, or terne metal, roofing: a to g, steps in forming a standing seam; h to m, joints at breaks in the roof.

on tight sheathing. Tongue-and-groove boards are recommended. The boards should be well seasoned and of uniform thickness. The deck can be covered with rosin-sized or other tar-free sheathing paper to deaden the noise of wind and rain on the roof.

Method.—If the roof slope is 3 inches or more per foot, a standing-seam roof should be laid. If the slope is less than 3 inches per foot, a flat-seam roof should be laid.

Figure 9 shows the details in laying a standing-seam roof. Form the seams as shown in *a* through *g* of the illustration. The cleats should be of the same material as the roofing and should be spaced 8 to 12 inches apart. Fasten them securely to the sheathing. The finished seam should be straight, rounded neatly at the top edge, and stand 1 inch above the roof surface. Standing seams are not soldered.

A flat-seam roof is laid in the same general way as a standing-seam roof (fig. 9), except that the seams are formed differently and are flattened on the roof. Figure 10 shows the method of forming flat seams. These seams should be soldered to make them watertight.

Galvanized Steel

Galvanized-steel roofing (fig. 11) is an economical and durable covering for farm buildings, if good materials are used and the roof is properly cared for.

Roofing made of alloy steel is more rust resistant than that made of plain steel, but durability depends chiefly on the protective zinc coating. Heavily galvanized roofing gives long service without painting. Lightly galvanized roofing must be kept well painted after it begins to rust.

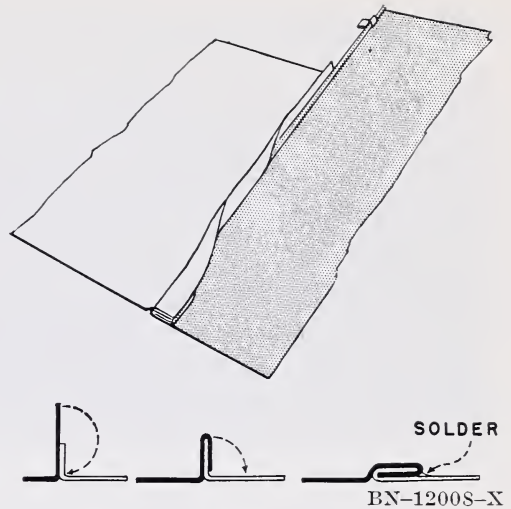

Figure 10.—Method of forming a flat seam.

Roofing with a guaranteed minimum coating of 2 ounces of zinc per square foot is on the market under a special “seal of quality.” This is a heavy coating, and the roofing will last a long time under normal conditions. For maximum service, however, it will need painting eventually.

Galvanized-steel roofing comes in different thicknesses, indicated by gage number. No. 28 gage or heavier is recommended for farm buildings. (The lower the gage number, the heavier the metal.)

Styles of galvanized-steel roofing commonly used on farm buildings are V-crimp sheets, corrugated sheets, and trapezoidal configurations of several shapes.

- V-crimp sheets are made to cover 24 or 30 inches allowing for side lap, and 6 to 12 feet long. They come with 2, 3, or 5 V-crumps. The 5-crimp sheets provide a more watertight roof, because they are laid with a side lap of 2 crumps.
- Corrugated sheets are 26 inches wide with 1½-inch corrugations, and 27½ inches wide with 2½-inch corrugations (24-inch coverage, in



BN-12005-X

Figure 11.—Laying corrugated galvanized-steel sheets.

both cases, allowing for side lap). They are available in lengths of 6 to 32 feet.

- Trapezoidal sheets are the strongest of the three styles and are available in the same widths, lengths, and thicknesses as the other two. Special sheets may cover 48 inches of width.

Following are installation details for sheet steel. Additional installation details may be obtained from manufacturers.

Deck.—Corrugated and trapezoidal sheets may be laid on (1) tight sheathing; (2) 1- by 4-inch or 1- by 6-inch roofing slats, spaced 2 feet apart, on top of rafters, spaced 2 feet on center; (3) 2- by 4-inch purlins on top of rafters; or (4) rafters with 2- by 4-inch headers cut between them.

V-crimp sheets should be laid on tight sheathing.

Tight sheathing under either type may be covered with rosin-sized sheathing paper.

Method.—Corrugated sheets are laid with a side lap of $1\frac{1}{2}$ corrugations. End lap is 9 inches if the roof slope is 4 inches rise per foot

run, and 6 inches if the slope is more than 6 inches rise per foot run. All laps should be made over supports.

Fasten the sheets at all laps and intermediate supports. Nail down through the tops of the corrugation. Space the nails about 8 inches apart. Screw-type or ring-shank nails are recommended. They should be long enough to fully penetrate the sheathing. The nails should have weather-protected heads, or neoprene washers should be used under the heads.

V-crimp sheets with 2 or 3 crimps should be laid with a side lap of 1 crimp. Those with 5 crimps should be laid with a side lap of 2 crimps. End lap and nailing is the same as corrugated sheets.

Flashing.—Flashings at hips, valleys, eaves, and chimneys should be of galvanized steel. Open valleys should be used; they should be lined with galvanized steel 1 or 2 gages heavier than the roofing. Special valley sheets are available.

Special ridge rolls, joints, and flashings for use at hips, eaves, and chimneys are available and will aid in making a tighter roof.

Painting.—Galvanized-steel roofing should weather for at least a year before it is painted. Clean the roof thoroughly before you paint. Remove rusted spots with a wire brush. Remove any loose nails and re nail. Do not paint unless the roof is absolutely dry. The best time is in warm, dry weather. When painting is needed, the proper application of a good zinc-base paint will extend the life of the roof considerably.

Aluminum

Aluminum roofing (fig. 12) is popular on farm buildings. Good grades of aluminum are highly corrosion resistant, require no painting, and have low maintenance cost.

Aluminum reflects a little more heat than steel. Reflection of the hot summer sun's heat keeps the interior of the building cooler.

Two styles of aluminum roofing commonly used on farm buildings

are V-crimp sheets and corrugated sheets.

- V-crimp sheets are made 26 inches wide with 5 crimps and about 50 inches wide with 8 crimps (24- and 48-inch coverage, respectively, allowing for side lap). In both widths, they are made 6 to 32 feet long, 0.019 inch and 0.024 inch thick, and have a smooth or embossed finish.

- Corrugated sheets with either 1¼- or 2½-inch corrugations are available in the same widths, lengths, and thicknesses as the V-crimp sheets.

Following are installation details for the corrugated sheets and V-crimp sheets. Additional details may be obtained from manufacturers.

Deck.—Corrugated sheets may be laid on tight sheathing, 1- by 6-inch boards spaced 12 inches on center, or 2- by 4-inch purlins spaced a maximum of 24 inches on center.

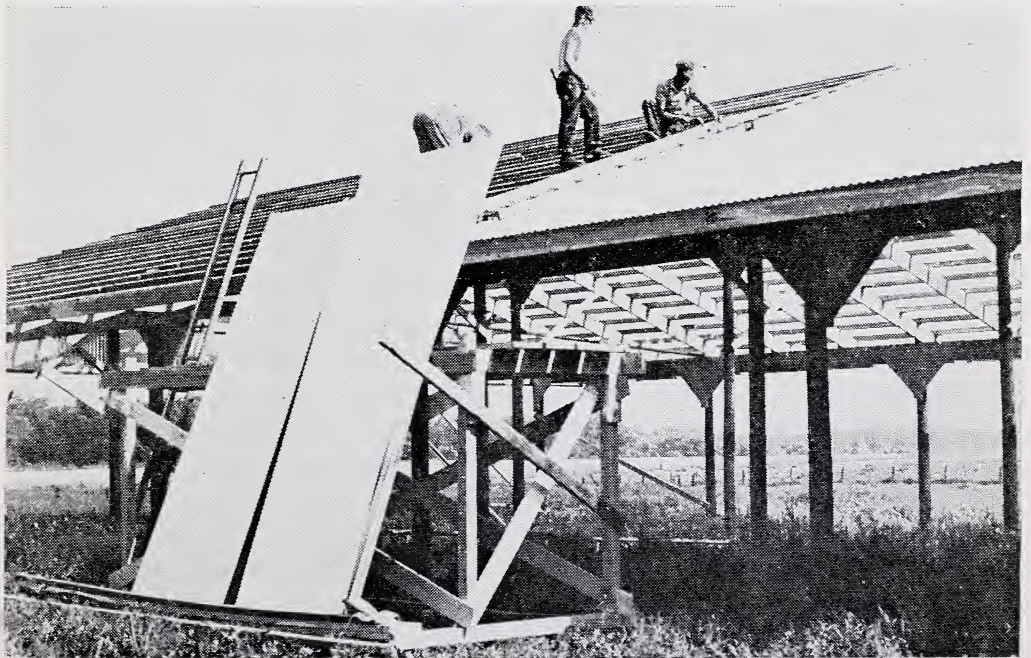

BN-12006-X

Figure 12.—Laying corrugated aluminum sheets.

Spacing of the purlins will depend on the weight of the sheets and varies with corrugation size and thickness of sheet.

V-crimp sheets may be laid on tight sheathing or sheathing boards spaced up to 6 inches apart.

Tight sheathing under either type should be covered with 15-pound or heavier asphalt-saturated felt. Lay the felt in horizontal courses, starting at the eaves, and lap the courses a minimum of 3 inches.

The roofing should not touch other kinds of metal. Cover steel nailheads in the sheathing (if not covered with asphalt felt) with asphalt-saturated felt or aluminum mastic. If metal purlins, other than aluminum, are used, coat them with aluminum-pigmented asphalt.

Method.—Corrugated sheets with 2½-inch corrugations are laid with a side lap of 1½ corrugations. Sheets with 1¼-inch corrugations are laid with a side lap of 2½ corrugations. Side laps should be away from the prevailing winds. End lap should be 6 inches or more. At the eaves, extend the sheets 2 inches beyond the edge of the deck to form a drip edge. Fasten the sheets by nailing through the tops of the corrugations. Use aluminum nails, with neoprene washers under the heads, long enough to fully penetrate the sheathing.

V-crimp sheets—5 or 8 crimps—should be laid with a side lap of 2 crimps. End lap is 6 inches or more. Fasten the sheets by nailing down through the tops of the V-crimps. Use aluminum nails with neoprene washers under the heads.

Flashing.—Aluminum flashing, 0.024 inch thick, should be used. Special ridge rolls, joints, and flashings are available for use at hips,

eaves, side and end walls, valleys, and chimneys.

Canvas Roofing

Canvas roofing is light in weight, long lived and watertight when kept well painted, and not hard to lay. It is particularly suitable for flat roofs that must be walked on, because it will not break readily.

The roofing is relatively high in cost, but is not expensive considering its durability. A good canvas roof, properly cared for, should last 25 to 30 years.

Canvas is made in two general classes—numbered duck and ounce duck. The difference is in the weaving. Numbered duck weighs from 7 to 20 ounces per linear yard 22 inches wide. No. 12 is the lightest and No. 00 the heaviest. Ounce duck weighs from 6 to 15 ounces per linear yard 28½ inches wide. It is made in three grades—army, double-filled, and single-filled. Of the three grades, only the army grade is suitable for roofing.

For roofing, canvas should be unbleached, unsized, closely woven, and not lighter than the 10-ounce grade. No. 6 (13-ounce) and No. 2 (17-ounce) are recommended for roofs that must be walked on a great deal.

Canvas is available in widths up to 120 inches. However, the 22-inch width of numbered duck and the 28½-inch width of ounce duck are generally used for roofing.

Following are installation details:

Deck.—Canvas must be laid on a smooth, tight surface. Tongue-and-groove flooring 2½ to 4 inches wide is recommended. Sheathing 6 to 8 inches wide could be used but is not so good because of

greater shrinkage. If the boards cup or warp, the raised edges will make ridges that will wear through the canvas.

Method.—There are several methods of laying canvas roofing. The following one is the most commonly used:

Paint the wood sheathing with a paint made of the following, if a light-colored roof is desired: 100 pounds of white-lead paste, 4 gallons of raw linseed oil, 2 gallons of turpentine, and 1 pint of liquid drier.

When this paint is thoroughly dry, apply a heavy coat of the white-lead paste.

Lay the first strip of canvas on the wet paste and press it down firmly. (Pressing it down with rollers will give a smoother surface.) Stretch the canvas slightly and fasten it along the edges with $\frac{3}{4}$ -inch copper tacks or galvanized nails, spaced 4 inches apart. Apply the white-lead paste along the edges. Lay the next strip of canvas with a lap of $1\frac{1}{2}$ inches. Nail the joint with $\frac{3}{4}$ -inch copper tacks, spaced $\frac{3}{4}$ inch apart.

After the canvas has been laid, apply three coats of paint. For the priming coat, use the same mixture that was used to paint the sheathing, except use 3 gallons of raw linseed oil instead of 4. For the second and third coats, use any good outside-type paint.

Flashing.—Canvas flashings should be used with canvas roofing. They are installed in the same way as are flashings of other materials.

Special Roofing Materials

Natural lighting—in addition to windows—may be desired in farm service buildings.

Translucent structural panels made of plastic reinforced with glass fibers or wire and sold under various trade names are available.

The panels are strong, light in weight, durable, fire resistant, and shatterproof and require no painting. They are available in various colors. They admit soft, diffused light—up to 80 percent as much light as clear glass.

The panels are made in flat, corrugated, and V-crimp sheets. Corrugated sheets may be used with corrugated metal roofing or corrugated asbestos-cement roofing. V-crimp sheets may be used with 5-V-crimp metal roofing. The panels come in the same widths and lengths as the metal or asbestos-cement sheets.

Installation of the panels is the same as for metal or asbestos-cement sheets. Details may be obtained from manufacturers.

SELECTION

The roof covering for a building should be carefully selected. Some important considerations are roof slope, weight of roofing material, cost, fire resistance, appearance, and location.

Roof Slope

Table 3 shows the minimum roof slope on which various types of roofing should be laid using the standard end or side lap. If the slope is less than that indicated, there will be danger of leaks.

Weight

Roofing materials vary in weight. Table 3 shows the approximate weight per square of different types. If the roofing is too heavy for the

framing, sagging may occur. A roof that sags is unsightly and hard to keep repaired.

Cost

Roofing materials vary widely in price. Cost in roofing, however, involves more than the cost of the materials. Labor, decking, scaf-

folding, and other factors make up a large part of the cost.

In selecting roofing from the standpoint of cost, keep these points in mind:

- Good-quality, long-lived roofing should be used on permanent buildings, even though the first cost is high. If maintenance, repair, and

Table 3.—Recommended minimum roof slope and approximate weight of various roof coverings

Type of roofing	Minimum rise per foot run with ordinary lap	Approximate weight per square ¹
	Inches	Pounds
Aluminum	4	30
Asbestos shingle:		
American multiple	5	300
American ranch	5	260
Asbestos, corrugated	3	300
Asphalt shingle:		
Lockdown	4	290
3-tab	4	210
Built-up roofing	½	600
Canvas (8 to 12 ounce)	½	25
Galvanized steel:		
Corrugated	4	100
V-crimp	2½	100
Roll roofing:		
Regular (2- to 4-inch lap)	4	100
Selvage edge (17- to 19-inch lap)	1	140
Slate	6	800
Tin:		
Standing seam	3	75
Flat seam	½	75
Wood shingles	6	200

¹ The different types of roofing vary in weight per square according to the weight or thickness of the roofing material itself.

replacement are considered, low-quality roofing can be more expensive in the long run.

- Long-lived roofing is warranted when the cost of applying the roofing is high in comparison with the cost of the materials, or when access to the roof is hazardous.
- If you are near the supply center, good-quality roofing may be available at lower-than-normal cost. For example, slate, one of the most durable roofing materials, usually is one of the more expensive. However, near a quarry, the price may be comparable with that of lower-quality, less-durable roofing.

Fire Resistance

Roofing materials vary in fire resistance. Slate, asbestos-cement shingles, and metal roofings are the most fire resistant. Others, such as asphalt shingles and roll roofing, provide satisfactory protection, if they are of good quality and are kept in good condition.

The dwelling and other important buildings should have a fire-resistant roof covering, if possible. Buildings closely grouped together—less than 150 feet apart—also should have fire-resistant coverings. If one catches fire, the danger of fire from flying sparks to the other buildings will be minimized.

Appearance

The roofs of buildings in a farm group should harmonize in color even though they may differ in contour or design.

Light-colored asphalt roofs usually absorb less heat than darker-colored roofs.

Location

Along seacoasts the air is saturated with salt; around industrial works it may be polluted with fumes. The salt and fumes may corrode galvanized or aluminum roofings and shorten their life. Steel roofing, even though galvanized, is particularly susceptible to such corrosion. If used, it must be kept well painted.

ESTIMATING ROOFING

Having selected the type of roofing, you will need to determine the amount of roofing material needed. This should be done by someone experienced in estimating roofing. The following is offered as a guide.

Roofing materials are commonly sold by the square (100 square feet). The number of squares needed will be determined by the area of the roof in square feet.

Figure 13 shows four types of roofs commonly used on farm buildings and a simplified method of determining the area of each.

The roofs shown in figure 13 are plain. If your roof has dormers, chimneys, and valleys, determine the area by sections and add.

Extra material is required for overhang at eaves and gables and for fitting around chimneys, dormers, and valleys. Include this in your estimate. Allow also for waste.

FLASHING

Flashing—strips of metal or other material—must be installed in the valleys between intersecting roof surfaces and where the roof joins chimneys and other vertical surfaces to make the roof watertight.

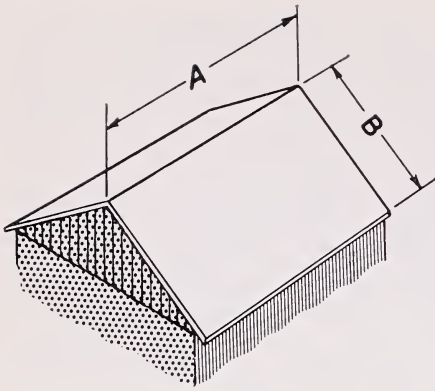

GABLE ROOF

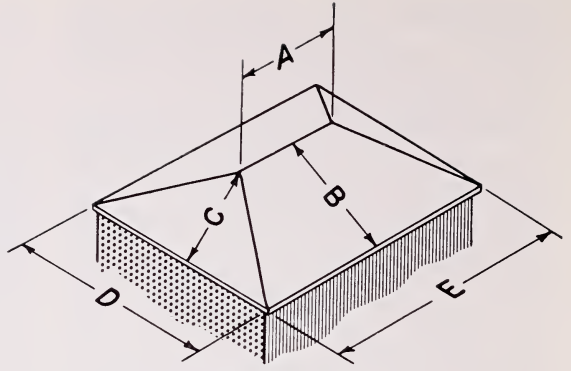

HIP ROOF

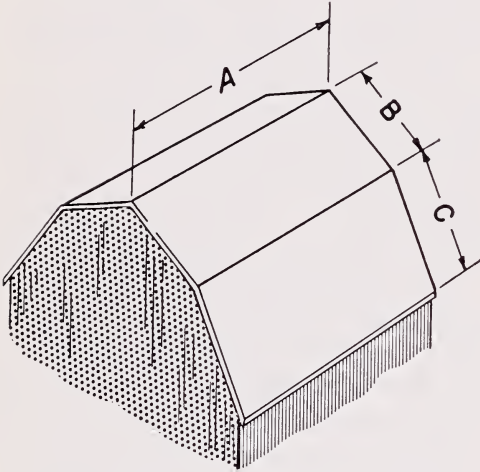

GAMBREL ROOF

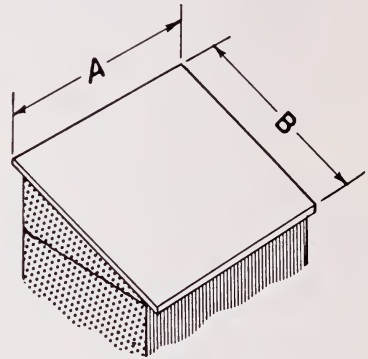

SHED ROOF

BN-12015-X

Figure 13.—METHOD OF DETERMINING AREA OF ROOF

Gable Roof.—Multiply roof length (A) by rafter length (B). Multiply by 2.

Hip Roof.—Step 1: Add roof length (A) and eaves length (E). Divide by 2. Multiply by rafter length (B). Multiply by 2. Step 2: Multiply longest rafter length (C) by eaves length (D). Step 3: Add figures obtained in steps 1 and 2 for total roof area.

Gambrel Roof.—Add rafter lengths (B and C). Multiply by roof length (A). Multiply by 2.

Shed Roof.—Multiply roof length (A) by rafter length (B).

Sheet metal—copper, aluminum, galvanized steel, or terne metal—is used for flashing with most types of roofing. Roll roofing or felt is used with bituminous roofings, and canvas with canvas roofing.

Special flashing materials are available. One type is steel sheets protected on both sides with baked-on coating or bonded asphalt-saturated fabric. Another type is a

double layer of bituminous felt reinforced with cotton or steel-wire mesh.

Painting

Zinc, lead, and aluminum flashings are not ordinarily painted. Copper is sometimes painted to prevent the staining of other surfaces. Paint will not last long on untreated copper. Before painting,

wash the surface of the copper with a solution of $\frac{1}{2}$ gallon of lukewarm water, 4 ounces of copper sulfate, and $\frac{1}{8}$ ounce of nitric acid. (Mix the solution in a glass container.) Wash the surface with water to remove all traces of the acid and allow it to dry.

Valley Flashing

Valleys may be open (fig. 14) or closed (fig. 15).

Open valleys should be at least 4 inches wide at the top and should widen out about $\frac{1}{8}$ inch per foot of length. Use flashing strips at least 20 inches wide.

When a valley is between roof surfaces of different areas or slopes, provide a baffle rib to prevent the larger or faster-descending volume of water from forcing its way up under the roofing on the opposite side. The baffle can be in the form of a V-crimp along the center line of the valley.

Figure 15 shows two methods of flashing closed valleys where rigid shingles are used. In *A*, a continuous strip of metal is laid under the

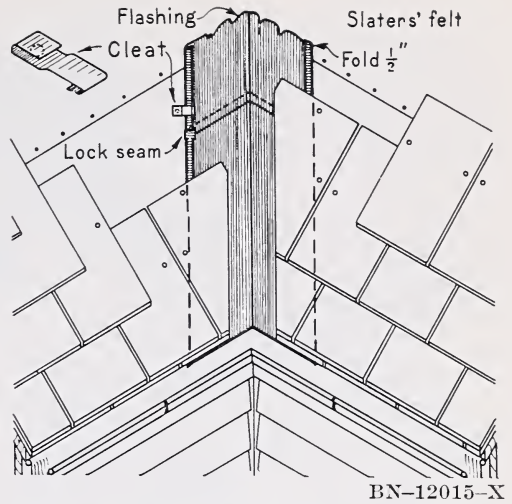

Figure 14.—Flashing in open valley.

shingles. In *B*, short pieces of metal are built in as the shingles are laid. If a prepunched nailhole in a slate or asbestos shingle falls over the metal flashing, provide a new hole. Each shingle should be fastened with two nails located outside the metal.

Vertical Flashing

Flashing at vertical surfaces, such as chimneys and walls, must extend up at least 6 inches and be

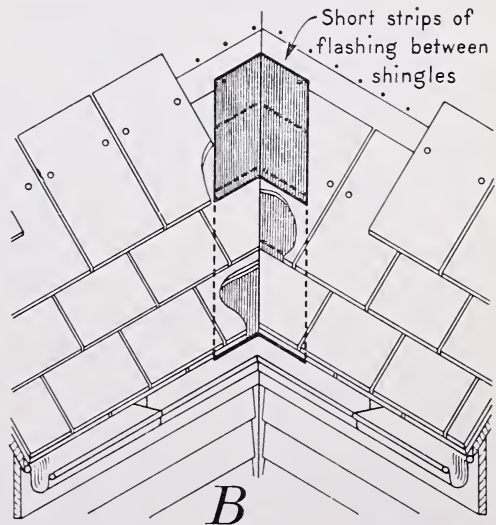
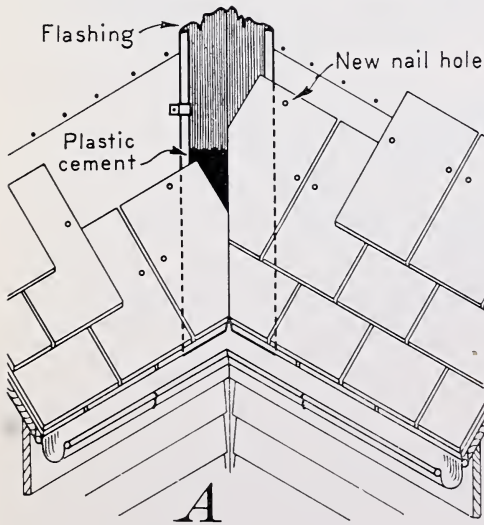
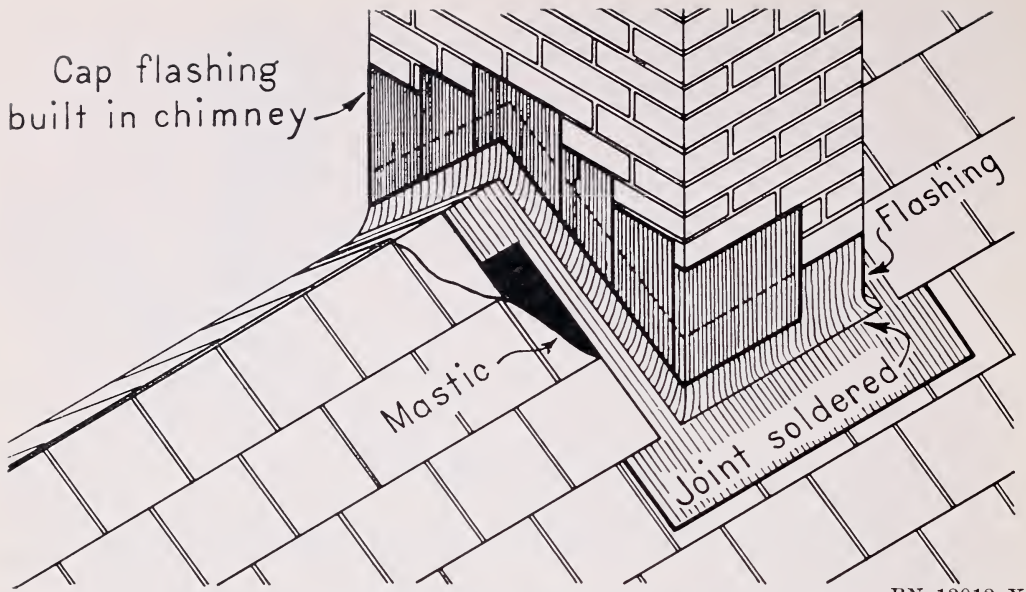
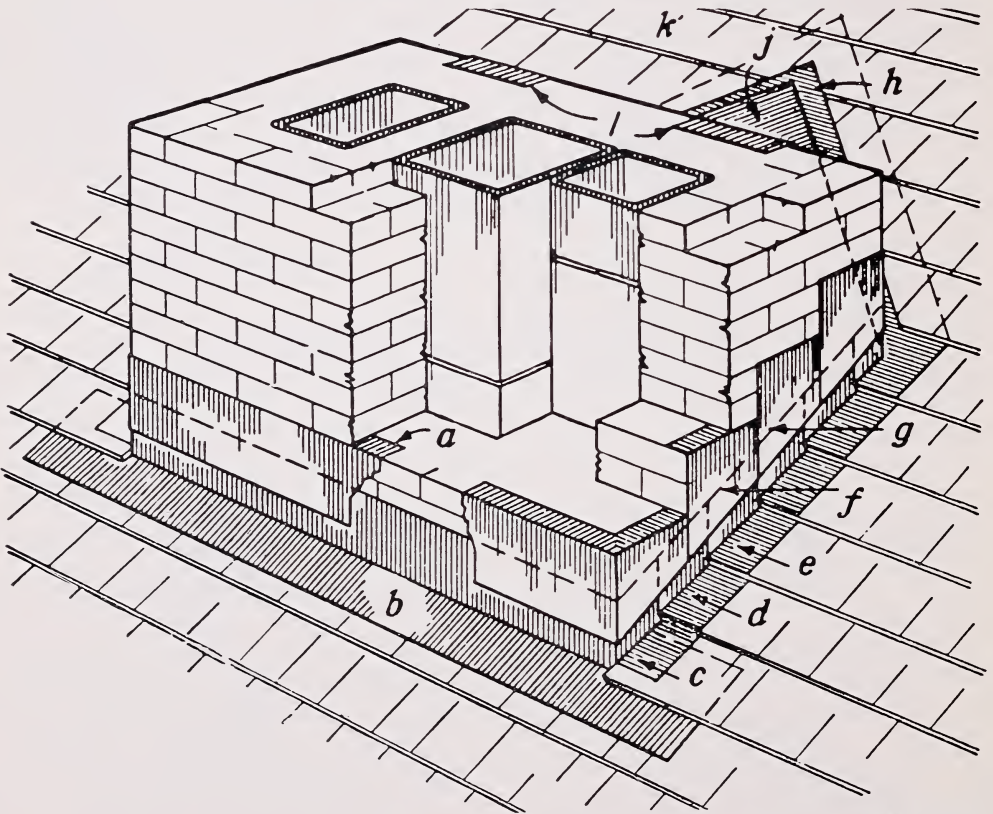

Figure 15.—Flashing in closed valley: *A*, Long metal strip under shingles; *B*, short pieces of metal intermembered with shingles.



BN-12012-X

Figure 16.—Flashing at chimney located on ridge.



BN-12009-X

Figure 17.—Flashing at chimney located on slope. Sheet metal (h), over the cricket, extends under the shingles (k) at least 4 inches and is counter-flashed at l in joint. Base flashings (b, c, d, and e) and cap flashings (a, f, and g) lap over the base flashings to provide watertight construction. Provide a full bed of mortar where cap flashing is inserted in joints.

counterflashed with cap flashing. The two flashings should not be fastened together rigidly.

Figure 16 shows the method of flashing a chimney located on the ridge. The cap flashing should be built into the joints when the masonry is laid. It should be folded down at least 4 inches over the base flashing that is installed at the same time as the roofing.

Figure 17 shows the method of flashing a chimney located on the slope. The cricket, or saddle, behind the chimney diverts water coming down the slope and prevents ice from forming behind the chimney.

Flashing around plumbing pipes extending through the roof must be installed so that the pipe can settle or expand without causing leaks.

GUTTERS AND DOWNSPOUTS

Gutters and downspouts are good investments, particularly in areas of high rainfall. They prevent the formation of water holes around buildings and damp conditions around foundations, and they reduce maintenance cost.

Gutters may be of wood built in as part of the cornice and lined with metal (fig. 18), or they may be metal troughs hung along the eaves (fig. 19).

Built-in gutters made of good materials will be more expensive than metal troughs, but maintenance cost will be considerably less. Built-in gutters should be wide and shallow and should be built entirely outside the wall line of the building. The outer edge should slope to prevent breakage when ice forms in the gutter.

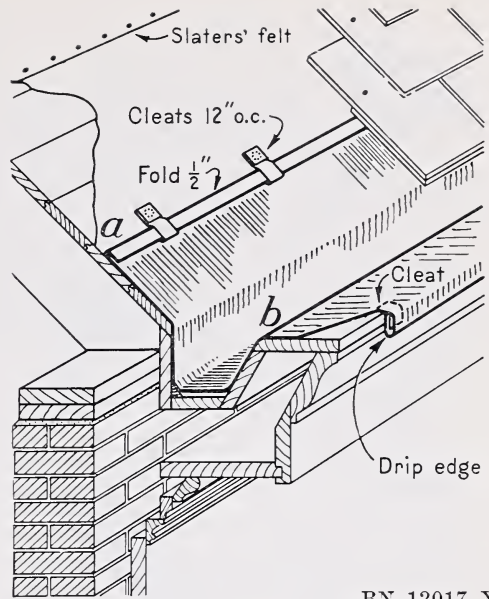

BN-12017-X

Figure 18.—Built-in gutter. Flashing should be at least 2 inches higher at *a* than at *b*.

In areas of heavy snowfall, the outer edge of a gutter should be $\frac{1}{2}$ inch below the extended edge of the roof. This is to prevent snow banking on the edge of the roof and causing leaks. Hanging metal troughs are better adapted to such construction.

Gutters should slope $\frac{1}{16}$ inch per foot toward the outlet to the downspout. This outlet should be larger in circumference than the downspout. Cover the outlet with a wire guard to prevent the accumulation of leaves and trash in the downspout.

Downspouts must be large enough to remove the water from the gutter satisfactorily.

Conductor heads or funnels (fig. 20) should be used where branch downspouts converge or at scuppers of flat roofs.

Join sections of downspouts by fitting the upper section inside the lower section. Soldering the joints is not recommended. Solder the

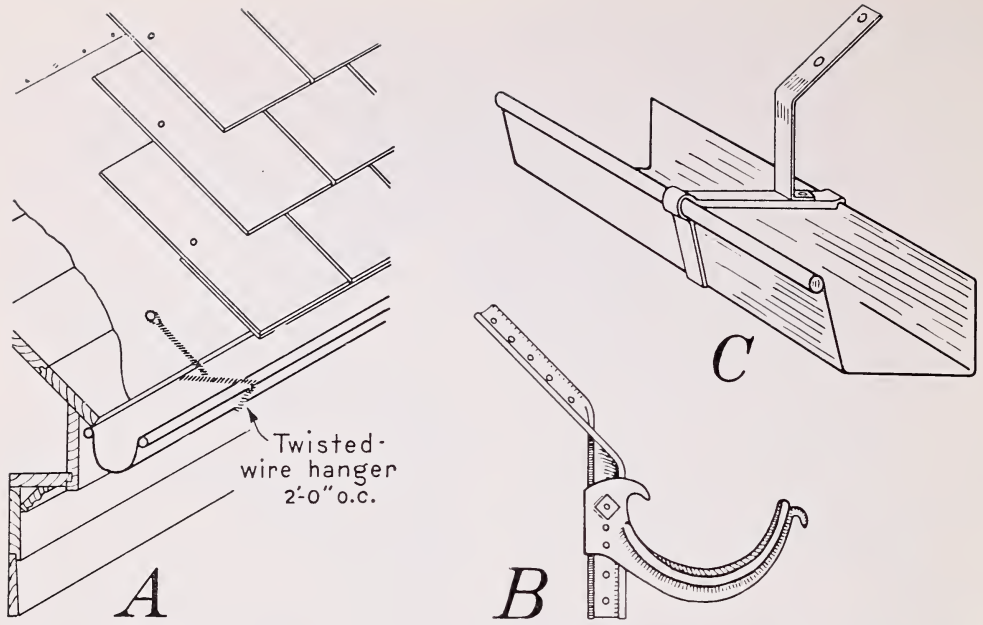

BN-12018-X

Figure 19.—Hanging eaves troughs: A, Half-round type; B, adjustable hanger; C, box type.

downspouts to the straps fastening them to the building.

On the lower end of a downspout, install—

- (1) a shoe, or turnout, if the water will merely drain away;
- (2) a cast-iron or tile pipe con-

nection or boot if the water will go into a storm sewer; or

- (3) a rain switch, or diverter, if part of the water will go into a cistern.

Gutters and downspouts should be large enough to carry off normal storm water flow. Intense rains may occur periodically and the gutters overflow. However, if they overflow only for the duration of the storm, little damage will be done.

Table 4 shows recommended sizes of downspouts and gutters for various roof areas. Local conditions may require larger sizes.

Install downspouts not more than 40 feet apart.

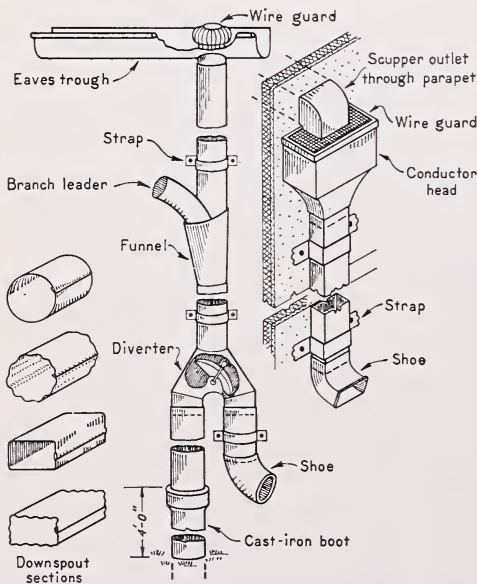

BN-12019-X

Figure 20.—Downspouts and fittings.

SNOW GUARDS

Snow guards (fig. 21) should be used on steep roofs in cold climates to prevent sheets of ice or snow from sliding. Sliding ice can tear off

Table 4.—Recommended sizes of gutters and downspouts for various roof areas

Roof area	Gutter diameter	Downspout diameter
Square feet	Inches	Inches
100–800.....	4	3
800–1,000....	5	3
1,000–1,400...	5	4
1,400–2,000...	6	4

roofing, break gutters, and endanger a person walking under the eaves.

Snow guards should be staggered in three rows near the eaves and spaced 6 to 12 inches apart. Sometimes, they are installed only over entrances or other traveled areas.

ROOF REPAIR

Inspect the roofs of your buildings frequently. Check for breaks, missing shingles, choked gutters, damaged flashings, and defective mortar joints at chimneys, parapets, and coping.

Repair defects promptly. Don't neglect small defects. They extend rapidly and involve not only the roof covering but also the sheathing, framing, and interior finish.

You can probably repair small defects yourself. Large defects or failures should be repaired by experienced persons. An inexperienced person may do more harm than good.

Locating Leaks

As soon as a wet spot appears on a wall or ceiling, inspect the roof to determine the cause. The location of the spot may indicate the

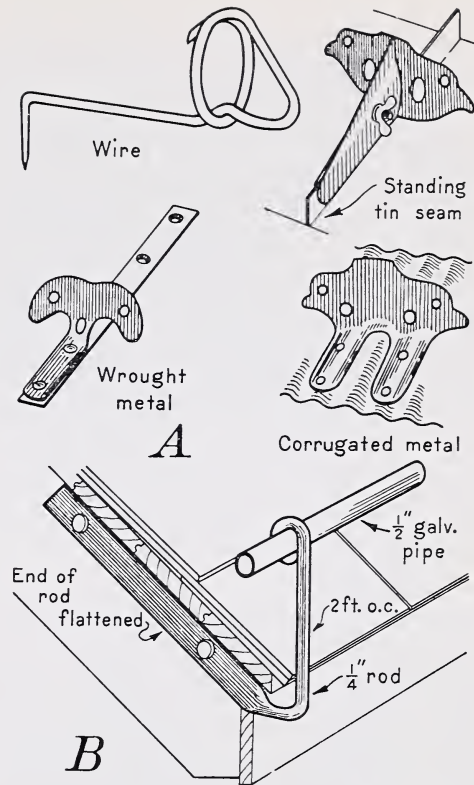

BN-12020-X

Figure 21.—Snow guards: A, Common types installed at the same time as the roofing; B, homemade type.

trouble. If it is near a chimney or exterior wall, look for defective or narrow flashing or loose mortar joints. On flat roofs, look also for choked downspouts or an accumulation of water or snow higher than the flashing. On sloping roofs, look also for corroded, loose, or displaced flashing and rotten shingles at valleys and at junction of dormers with the roof.

Other frequent causes of leaks are:

- Holes in the roof covering—generally the cause on plain roofs.
- Loose or defective flashing around cupolas and plumbing vent pipes.
- Gutters so arranged that when choked they overflow into the house.

- A ridge of ice along the eaves that backs up melting snow under the shingles.
- Water leaking from downspouts splashes against a wall and enters through a defect.

Shingles

Replace missing shingles with the same kind of shingle or a piece of rust-resistant metal. In an emergency, make a temporary repair with metal cut from a tin can.

If metal is used, paint it on both sides. Slip it under the shingle in the course above. Be careful not to dislodge sound shingles.

Metal Roofing

Close small holes in steel or tin roofing with a drop of solder. Solder a patch of the same kind of metal over large holes. If soldering tools are not handy, seal small holes with elastic roofer's cement. Paste a piece of canvas over large holes, using paint as the adhesive. Apply several coats of paint over the patch.

Close small holes in aluminum roofing with a sheet-metal screw and neoprene washer or with an aluminum-pigmented calking compound. Holes up to $\frac{3}{8}$ inch in diameter can be closed also with cold solder. Holes over $\frac{1}{2}$ inch in diameter should be covered with an aluminum patch. Coat the patch with aluminum-pigmented calking

mastic, and fasten it with sheet-metal screws.

New short sheets may be used to repair large defects in metal roofing. If the defect is near the bottom of the old sheet, remove several fasteners, slip the new sheet under the damaged area, and refasten the old sheet in the same holes. If the defect is near the top, follow the same procedure, but place the new sheet over the damaged area.

Metal roofing may become riddled with small holes. An application of a heavy-brushing bituminous coating may be effective.

Flashing

Repairs to flashing should be made at the time the roofing is repaired or when inspection shows defects.

Fasten loose flashing securely in place and fill the joint with roofer's cement. If the joint is wide, oakum rolled in roofer's cement may be calked in the joint.

Replace badly corroded metal in open valleys. Closed valleys are harder to repair. Where leaks occur, try to slip a piece of metal—a square piece folded on the diagonal—up under the shingles. If this cannot be done readily, call in a roofer.

Rake out loose mortar in chimney joints, and repoint the joints with a mixture of 1 part portland cement, 1 part lime, and 6 parts sand.

BN-11994-X, 11997-X, 11993-X, 11996-X, 11992-X, 11995-X

Figure 22.—Laying new shingles over old: A, Cut away 2 to 4 inches of the old shingles along eaves and gables; B, nail on wood strip to provide a firm nailing base; C, nail wood strip, level with the old shingle surface, in open valleys and lay new metal valley sheet on top of wood strip; D, lay a double course of new shingles at eaves; E, install new chimney flashing; F, nail strips of bevel siding, thin edge down, at ridges to provide a solid nailing base.



A



B



C



D



E



F

NEW ROOFING OVER OLD

When you plan to reroof an old building, consider laying the new covering over the old. This is not always possible or desirable, but there are advantages.

- The old roofing will provide additional insulation.
- You can lay the new roofing without exposing the interior of the building or the sheathing to the weather.
- You avoid the labor, expense, and mess of removing the old covering.

The roof framing must be strong enough to support the additional weight. If your roofing is exceptionally heavy (see table 3), you may have to brace the rafters; or, if they cannot be properly braced, you may have to remove the old covering.

Rigid shingles and metal roofings may be laid over old roll roofing and asphalt shingles, if the surface is not puffy or badly wrinkled. Puffy areas should be slit or cut and the old roofing nailed flat. If

the new roofing is metal, cover the old roofing with rosin-sized paper (asphalt-saturated felt for aluminum).

Metal roofings may be laid over old wood shingles. Nail 2- by 4-inch nailing strips over the shingles, parallel to the eaves. Fasten the strips to the decking. For lightweight aluminum roofing, space the strips 16 inches on center. For steel roofing, space the strips 24 to 30 inches on center. End laps of the metal roofing sheets should be over strips. If the new roofing is aluminum, cover nailheads in the strips with aluminum-pigmented mastic or asphalt-saturated felt.

New wood shingles may be laid over old. First, nail flat and secure all curled, badly warped, and loose shingles, and hammer down all protruding nails. Then follow the steps in figure 22. Use fivepenny nails $1\frac{3}{4}$ inches long for the new shingles. The old shingles may have been laid on lath or strips. However, in nailing the new shingles, it is not necessary that the nails strike these strips.