

5-15

MHI
Copy 3

FM 5-15

DEPARTMENT OF THE ARMY FIELD MANUAL

FIELD FORTIFICATIONS



HEADQUARTERS, DEPARTMENT OF THE ARMY
OCTOBER 1959

FIELD MANUAL }
 No. 5-15

HEADQUARTERS
 DEPARTMENT OF THE ARMY
 WASHINGTON 25, D. C., 8 October 1959

FIELD FORTIFICATIONS

| | Paragraphs | Page |
|--|------------|------|
| PART ONE. INTRODUCTION | | |
| CHAPTER 1. INTRODUCTION..... | 1, 2 | 3 |
| 2. GENERAL..... | 3-5 | 4 |
| PART TWO. FUNDAMENTALS OF PROTECTION | | |
| CHAPTER 3. PROTECTION OF PERSONNEL AND INDIVIDUAL WEAPONS | | |
| Section I. Protection from effects of conventional weapons.. | 6-11 | 7 |
| II. Protection from effects of chemical and biological weapons..... | 12-14 | 9 |
| III. Protection from effects of nuclear weapons..... | 15-18 | 11 |
| IV. Comparison of protection required..... | 19, 20 | 18 |
| CHAPTER 4. PROTECTION OF CREW SERVED WEAPONS, COMBAT EQUIPMENT, AND MATERIEL | | |
| 5. PROTECTION OF UNITS..... | 21, 22 | 20 |
| 6. PROTECTION OF ADMINISTRATIVE SUPPORT INSTALLATIONS..... | 23-26 | 22 |
| 6. PROTECTION OF ADMINISTRATIVE SUPPORT INSTALLATIONS..... | 27-31 | 27 |
| PART THREE. MEANS OF PROVIDING PROTECTION | | |
| CHAPTER 7. GENERAL | | |
| Section I. Materials and methods..... | 32-35 | 34 |
| II. Construction of overhead cover in functional layers..... | 36-40 | 42 |
| III. Revetments for earth banks..... | 41-44 | 46 |
| IV. Drainage..... | 45-48 | 56 |
| CHAPTER 8. PERSONNEL AND INDIVIDUAL WEAPONS | | |
| Section I. Emplacements..... | 49-53 | 61 |
| II. Shelters..... | 54-58 | 85 |
| CHAPTER 9. CREW SERVED INFANTRY WEAPONS, COMBAT EQUIPMENT AND MATERIEL | | |
| 10. ARTILLERY WEAPONS..... | 59-71 | 100 |
| 10. ARTILLERY WEAPONS..... | 72-78 | 127 |

***This manual supersedes FM 5-15, 17 August 1949, and TB ENG 117, 19 December 1955.**

| | Paragraphs | Page |
|--|------------|------|
| CHAPTER 11. ACCESSORIES FOR EMPLACEMENTS AND SHELTERS | | |
| Section I. Firing Ports..... | 79-82 | 135 |
| II. Illumination..... | 83, 84 | 137 |
| III. Entrances..... | 85-89 | 141 |
| IV. Heating..... | 90-93 | 147 |
| PART FOUR. OBSTACLE EMPLOYMENT | | |
| CHAPTER 12. GENERAL..... | 94-97 | 155 |
| 13. PRINCIPLES OF EMPLOYMENT OF ARTIFICIAL LAND OBSTACLES | | |
| Section I. General..... | 98-104 | 157 |
| II. Minefields..... | 105, 106 | 159 |
| III. Barbed wire entanglements..... | 107-109 | 160 |
| IV. Antivehicular obstacles..... | 110, 111 | 165 |
| CHAPTER 14. PRINCIPLES OF EMPLOYMENT OF ARTIFICIAL BEACH AND RIVER LINE OBSTACLES..... | 112-115 | 166 |
| 15. PRINCIPLES OF EMPLOYMENT OF NATURAL OBSTACLES..... | 116-118 | 170 |
| PART FIVE. OBSTACLE CONSTRUCTION | | |
| CHAPTER 16. BARBED WIRE ENTANGLEMENTS | | |
| Section I. Materials..... | 119-123 | 171 |
| II. Construction procedures..... | 124-132 | 177 |
| III. Material and labor estimates..... | 133, 134 | 203 |
| CHAPTER 17. ANTIVEHICULAR OBSTACLES..... | 135-146 | 205 |
| 18. NATURAL LAND OBSTACLES..... | 147, 148 | 223 |
| 19. BEACH AND RIVER LINE OBSTACLES..... | 149-154 | 227 |
| APPENDIX I. REFERENCES..... | | 237 |
| II. FORTIFICATION PROTECTION FACTORS..... | | 239 |
| III. ILLUSTRATIVE EXAMPLES OF INSTALLATIONS DISPERSAL..... | | 246 |
| IV. FIELD DESIGN PROCEDURES..... | | 261 |
| INDEX..... | | 265 |

PART ONE
INTRODUCTION
CHAPTER 1
INTRODUCTION

1. Purpose

This manual provides information on the use of field fortifications and obstacles in proper combinations with mobility and dispersion for the protection of individuals, units, and administrative support installations in the field.

2. Scope

a. The manual describes the employment and construction of unit-construction field fortifications as defined in paragraph 3*a*. The capabilities and limitations of each fortification are discussed; and standard plans, bills of materials, construction procedures, and time and labor requirements are furnished.

b. The fortifications and techniques of protection described in this manual, are applicable to all field army units.

c. Field design procedures for structures to support overhead cover are included in appendix IV.

d. This manual is written with the assumption that the reader is familiar with the employment and effects of nuclear weapons as described in DA Pams 39-1 and 39-3.

e. The material herein is applicable without modification to both nuclear and nonnuclear warfare.

CHAPTER 2

GENERAL

3. Types of Field Fortifications

Field fortifications are constructed by all arms and services. Engineer troops assist the units which are to occupy these fortifications and in addition may be made entirely responsible for all fortifications in a specific area. The two types of field fortifications and their definitions are listed below.

a. Field Fortifications—Unit Construction. These fortifications are emplacements and shelters of temporary construction which can be constructed with reasonable facility by using units with no more than minor engineer supervisory and equipment participation.

b. Field Fortifications—Engineer Construction. These fortifications are emplacements and shelters of temporary construction which require construction by engineer troops with or without assistance from using units.

4. Responsibilities

a. It is the responsibility of the commander of troops occupying positions or installations to lay out and construct field fortifications.

b. The staff engineer at all levels of command assists in preparation of plans and orders and performs technical inspections with respect to field fortifications. Engineer staff officers and engineer technical advisory personnel must be familiar with the tactical and administrative support considerations which affect the organization of the ground in order to provide proper technical assistance and advice.

c. The duties of engineer troops in the construction of field fortifications by the using units are—

- (1) To supply field fortifications materials and hand tools.
- (2) To furnish technical advice and assistance.
- (3) To furnish and operate engineer construction equipment as appropriate.

5. Definition of Terms

The following terms are used in planning and constructing field fortifications.

a. Blast Loading. The loading (or force) on an object or structure caused by the air blast from an explosion striking and flowing around

the object. It is a combination of overpressure (or diffraction) and dynamic pressure (or drag) loading.

b. Concealment. The act or result of actions designed to hide or disguise men or material from the enemy; the application of techniques of camouflage or screening or both, with the aim of denying information as to the existence, nature, disposition, or purpose of installations, equipment, or activities. Concealment offers protection from observation only.

c. Cover. Shelter or protection, either natural or artificial, from enemy fire.

d. Deception. Any activity the aim of which is to draw attention; the use of any measure, the aim of which is to mislead by misrepresenting any installation, equipment or activity.

e. Defilade. Protection or shielding from hostile ground observation and flat trajectory fire, provided by a natural or artificial obstacle such as a hill, ridge, or bank.

f. Drag Loading. The forces exerted upon an object or structure by the dynamic pressures from the blast wave of a nuclear explosion. These forces are influenced by certain characteristics of the object or structure, primarily its shape.

g. Emplacement. A prepared position for one or more weapons or pieces of equipment for protection against hostile fire or bombardment, and from which they can execute their tasks. Emplacements include foxholes and trenches.

h. Enfilade Fire. Fire in which the long axis of the beaten zone coincides with the long axis of the target; e.g., fire in the direction of the length of a line or column.

i. Gap. A portion of a barrier in which no obstacles exist. It is wide enough to enable a friendly force to pass through in tactical formation.

j. Incident Radiation. Radiation which falls upon, strikes or affects a certain plane of reference.

k. Lane. A clear route through an obstacle. A single lane is normally 8 yards wide; a double lane is 16 yards wide. Lanes must be suitably marked.

l. Obstacle. Any obstruction (natural terrain feature, condition of soil or climate, or manmade object) that stops, delays, or diverts movement.

- (1) Natural obstacles include steep slopes, rivers, gullies, swamps, heavy woods, thick jungle, and deep snow and manmade objects, such buildings or walls, not originally erected to serve as obstacles but which may be employed as such.
- (2) Artificial obstacles include works of destruction and construction, such as demolished bridges; road craters; abatis; flooding; minefields; contaminated areas; wire entanglements; road-blocks; antitank ditches, and log, steel, and concrete structures.

m. Physical Protection. The use of natural or artificial physical means to provide protection from weapons effects. Some examples of physical protection are protective clothing, armored vehicles, emplacements, shelters, parapets, trenches and natural terrain conditions.

n. Reaction Time. The time that elapses between an action and a counteraction.

o. Revetment. A retaining wall or facing, constructed from sandbags, boards, brush, or other materials which hold earth slopes at steeper angles than could normally be maintained without caving or sliding.

p. Shelter. Any natural or artificial cover which protects troops, ammunition, or supplies from enemy action or inclement weather. No provisions are made for firing weapons from shelters.

q. Translation. Lateral movement caused by drag loading.

r. Trench. An excavation of standard dimensions which connects other emplacements and shelters.

PART TWO

FUNDAMENTALS OF PROTECTION

CHAPTER 3

PROTECTION OF PERSONNEL AND INDIVIDUAL WEAPONS

Section I. PROTECTION FROM EFFECTS OF CONVENTIONAL WEAPONS

6. General

a. Methods of Providing Protection. Protection against conventional weapons is best provided by putting an adequate thickness of shielding material between the target and the weapon or weapon fragments. In the field this is most easily done by digging into the ground so that the personnel or equipment to be protected is not exposed to the line of sight of the weapon. This provides excellent protection against direct fire weapons, horizontally impelled fragments, small arms and the crushing action of tanks. Digging into the ground also affords protection against artillery, infantry heavy weapons, bombs and other aerial weapons. To improve protection against this latter group of weapons, overhead cover must be constructed. The added protection depends on the strength and thickness of the cover. If this cover extends above the ground sufficiently to provide a target for direct fire weapons, the protective value of the emplacement or shelter may be reduced. Similar reduction in the protective value of the emplacement or shelter may result from extending the structure above the level of the ground to provide firing apertures. If surface structures are covered with earth they may provide protection comparable to subsurface structures. However, the surface structure must be of stronger construction and the thickness of the earth cover and the effort required to place and compact it may be excessive.

b. Protection Afforded. The protection afforded by each of the standard emplacements and shelters against the effects of conventional weapons is presented in chapter 8.

7. Close Combat Weapons

Emplacement design should provide for defense against close combat weapons as listed below.

a. Grenades. The emplacement itself provides a shield between the

occupants and a grenade exploding outside the emplacement. Shielding is accomplished inside the emplacement by a grenade sump, in which the grenade may explode harmlessly.

b. Bayonet or Rifle Butt. Most emplacements offer little protection from a bayonet or rifle butt except by denying entry to the person wielding the weapon. Actually, certain emplacements may increase vulnerability to bayonet or rifle butt attack by hindering effective counteraction by the personnel inside. Where possible, without significantly reducing the other protection provided, emplacements should permit rapid, easy exit.

c. Demolition Charges. The effect of demolition charges such as the pole charge and satchel charge is minimized by the shielding material of the emplacement between the occupant and the exploding charge.

8. Small Arms

Firearms, such as rifles, carbines, pistols, and machineguns, are classified as small arms. These firearms may inflict casualties directly or through ricocheting fragments of solid materials. They are normally fired on a flat trajectory. Two to six feet of earth or a lesser amount of more impervious material will provide protection from small arms.

9. Conventional Artillery and Infantry Heavy Weapons

Attacks by these weapons fall into two general categories.

a. Direct Fire. Recoilless rifles, assault guns, tank guns, bazookas, and small guided missiles are considered to be direct fire weapons. They have a flat trajectory and a high penetrating power which may be increased by a shaped charge in the missile. Because of this flat trajectory, emplacements and shelters below ground level provide good protection against direct fire weapons. Emplacements and shelters which protrude above ground surface offer a silhouette as a target and hence are much more vulnerable to direct fire weapons. When it is necessary that emplacements or shelters protrude above the ground surface they should be provided with a sloping cover. This decreases their vulnerability to direct fire weapons, since it increases the probability of the projectiles ricocheting from the cover.

b. Indirect Fire.

- (1) Mortars, howitzers, most free rockets and guided missiles and other artillery weapons are indirect fire weapons. The most widespread casualty producing effect of these weapons is their fragmentation. Subsurface positions with small openings, such as foxholes, provide excellent protection from these fragments, except those resulting from overhead bursts. Protection may be increased by adding 18 inches of overhead cover which is sufficient to stop most fragments. Occasionally a horizontal sweep of fragments may cause casualties through openings in

surface emplacements and shelters which have adequate overhead cover.

- (2) Direct hits from indirect fire weapons can cause casualties in emplacements and shelters through earth covers up to 12 feet thick, depending on the fuzing and the size of the weapon and the construction of the emplacement. A protective cover constructed in functional layers supported by a roof constructed of laminated planks (described in ch. 7) gives the best protection, against conventional weapons, per foot of cover thickness. Three feet of such cover will survive a direct hit from a 155-mm shell.

10. Bombs and Other Aircraft Delivered Weapons

Bombs other than direct hits or very near misses will tend to produce fragment patterns similar to surface burst indirect fire. Consequently, shelters and uncovered emplacements afford good protection. Only thick overhead cover of materials arranged in functional layers will provide protection from direct hits or near misses. Aircraft rockets are similar to artillery direct fire weapons except that they have a greater capability for attacking a target at ground level, such as the opening of a foxhole. Aircraft machineguns and small caliber cannon are similar in their effects to small arms and small direct fire infantry heavy weapons except that they also have a better capability for attacking low silhouette targets. Certain types of air-delivered weapons, such as small antipersonnel mines, may be dropped in high densities over wide areas. Overhead cover which can resist penetration will provide protection from these latter weapons.

11. Tracked Vehicles

Tracked vehicles can destroy or damage emplacements and shelters and cause casualties within them by their crushing action in addition to the use of direct fire weapons. Small emplacements or shelters which are deep enough permit the surrounding earth to sustain the weight of tracked vehicles without crushing the fortification or injuring its occupants.

Section II. PROTECTION FROM EFFECTS OF CHEMICAL AND BIOLOGICAL WEAPONS

12. General

Enemy use of chemical and biological agents and weapons must be considered in discussing the employment of emplacement and shelters. Although emplacements and shelters do not offer complete protection from such weapons, provision can often be made for partial protection. The protection afforded by each of the standard emplacements and

shelters against the effects of chemical and biological agents and weapons is presented in chapter 8.

13. Protection Afforded By Emplacements

a. Napalm and Flamethrowers. Protection from napalm and flamethrowers requires that the burning jelly or fuel be excluded from the emplacement and that adequate breathable air be retained in the emplacement. Covered emplacements with relatively small apertures and entrance areas which can be closed, provide protection from napalm and flamethrowers.

b. Gas, Liquid Contaminants and Biological Agents. Deep emplacements, unless they are constructed so as to permit airtight sealing, generally increase the hazard from gas, because gas tends to settle in low places. Overhead cover alone over an emplacement provides no protection from gas. Emplacements which have overhead cover and protected apertures provide protection from the direct hazard of liquid contaminants. A collective protector (gas particulate filter unit) is required for effective protection from the effects of casualty gases because the occupants of a closed emplacement or shelter would exhaust the air supply inside within a relatively short time, depending on the size of the emplacement or shelter. For personnel in open or partially open emplacements, the best protection against casualty gas and aerosol borne biological agents is the use of the protective mask.

14. Protection Afforded By Shelters

Fully covered shelters with properly protected openings provide excellent protection from napalm and flamethrowers. However, if the enemy fires a flamethrower into the shelter all occupants would probably die of either burns or asphyxiation. Protection from effects of gas and biological agents depends on the type of shelter. Crude, hasty shelters provide protection similar to that provided by emplacements with overhead cover. Shelters can be improved so that they are airtight and incorporate collective protectors (gas particulate filter units) as described in TM 3-350. If the gas particulate filter unit provides sufficient air to maintain a slight positive pressure inside the shelter, airtightness is not required, since any leakage would be from inside to outside the shelter. Biological agents aerosols act in a fashion similar to that of gas. Covered shelters generally are capable of excluding liquid agents. The possibility that liquid contaminants may be inadvertently introduced into the shelter on clothing and equipment must be considered.

Section III. PROTECTION FROM EFFECTS OF NUCLEAR WEAPONS

15. General

The effects of nuclear weapons from which protection of personnel and their individual weapons is required are—

- a. *Blast (direct and indirect).*
- b. *Nuclear radiation (initial and residual).*
- c. *Thermal radiation (direct and indirect).*

The protection afforded by each of the standard emplacements and shelters from the effects of nuclear weapons is described in chapter 8.

16. Protection From Blast Effects

a. *General.* The blast effect of nuclear weapons acts on the personnel within an emplacement or shelter as well as on the emplacement or shelter itself.

b. *Effects From Which Protection Is Required.*

(1) Direct effects of the blast:

- (a) Overpressure.
- (b) Drag loading.

(2) Indirect effects of the blast:

- (a) Physical injury to occupants resulting from collapse or failure of the emplacement or shelter due to blast loading, air induced ground shock, or tree blowdown.
- (b) Physical injury as a result of tree blowdown or flying debris.
- (c) The loss of protection from other effects of nuclear weapons (thermal and nuclear radiation), conventional, and chemical and biological weapons as a result of collapse or failure of the emplacement or shelter.

c. *Protection From Direct Effects.*

- (1) *Overpressure.* The effect of overpressure alone on personnel is, with one exception, not militarily significant because the pressure required to cause serious casualties is so high that personnel exposed to such pressure will normally also be subjected to lethal indirect blast effects and lethal radiation doses. Multiple reflections of the blast wave inside a shelter may, however, build overpressure up to significant levels. The use of blast-proof entrances will reduce this hazard. The one result of overpressure on personnel which is an exception is eardrum rupture which will occur between 7 and 15 psi overpressure. Such an injury may impair the combat efficiency of those sustaining it but should not require their evacuation.
- (2) *Drag loading.* Shelters and below ground emplacements give good protection from drag loading. Within the position itself, the area near doors and entranceways is most susceptible to

drag effects and incoming debris. This is especially true in shelters with more than one entrance. Blast-proof entrances are required to protect personnel inside an emplacement or shelter from injury by translation, resulting from drag loading inside the structure. Completely blast resistant entrances are not practical for most field fortifications, but some additional protection can be obtained by constructing baffles in the entrances. The degree of protection afforded by a foxhole against injury resulting from translation is not too well known at present. However, appreciable protection should be provided if the foxhole is deep enough to prevent the occupant from being thrown out.

d. Protection From Indirect Effects.

- (1) *Physical injury.* Some protection from physical injury resulting from the collapse or partial failure of an emplacement or shelter due to drag loading, air-induced ground shock or tree blowdown can be provided by well-designed and well-constructed positions. Subsurface fortifications used in conjunction with low parapets provide the best protection in forested areas. Structures which protrude above the ground required overhead cover strong enough to support fallen trees. Damage to an emplacement or shelter which is sufficient to produce physical injury to its occupants will usually result in a loss of protection from other weapons effects. Means of preventing such loss are discussed in the following paragraphs.
- (2) *Debris hazard.* If an individual is inside an emplacement or shelter, considerable protection from flying debris is provided, depending on the design of the position and the amount of equipment within the position which might itself form a debris hazard. Small, deep, relatively closed positions such as foxholes provide the best protection. Wide, shallow, open positions such as artillery emplacements provide the poorest protection. The protection provided by an emplacement or shelter can be improved if the loose equipment within is kept to a minimum.
- (3) *Loss of protection in open emplacements.*
 - (a) *Unrevetted.* Blast damage to an unrevetted emplacement is caused by the failure of the soil to withstand air-induced ground shock. Soils vary in their susceptibility to this ground shock. In most soil firm enough to otherwise sustain an unrevetted emplacement, 25 psi or more will normally be required for actual wall collapse. Unrevetted walls in a cohesive soil may show almost no structural damage while the same unrevetted emplacement in a less cohesive soil such as sand, will collapse. However, an estimate of

soil stability based only on cohesive qualities is not valid because of such variable characteristics of soil as previous disturbance and moisture and air content. The degrees of damage shown in table I for unrevetted emplacements are based on the level to which the emplacement was filled as a result of the introduction of dust and debris. (Shock susceptible soils such as loess can be expected to fail at much lower overpressure ranges.) In loose gravelly soils, dust and debris can sometimes almost completely fill an emplacement at overpressures as low as 5 psi because this type of soil provides excellent debris material. Such fill may make weapons temporarily inoperative and cause casualties by choking or entrapping the occupants of the emplacements.

Table I. Fill Damage To Unrevetted Open Subsurface Emplacements (Loose Gravelly Surface)

| Overpressures | Degree of damage |
|---------------|------------------|
| 20 psi----- | Severe |
| 12 psi----- | Moderate |
| 4 psi----- | Light |

Severe — At least 50 percent filled.
 Moderate — Less than 50 percent and more than 10 percent filled.
 Light — Less than 10 percent filled.

- (b) *Revettted.* The blast overpressure necessary to collapse revettted emplacements depends upon the soil type, the revettment material and the construction procedure used but will normally exceed that required to collapse unrevetted emplacements. Revetting will not prevent fill damage resulting from blown-in material, so table I will generally apply to revettted positions in loose gravelly soil.
- (4) *Loss of protection in covered emplacements.* Overhead cover for emplacements and shelters has considerable importance in protection from the indirect effects of blast. Unless the overhead cover is well constructed it can impair the overall protective value of the emplacement or shelter since its failure may result in direct injury to the occupants as well as a greater probability of injury to personnel from other effects. The forces acting on the overhead cover are produced by its own weight, the differential pressure on its faces, impact of pressure wave, and if above ground, drag pressure. Overhead covers above ground have a tendency to be blown away while those even with or below the ground surface may tend to fail either inward or outward. Inward failure of cover results in a high probability of injury to the occupants.

- (5) *Loss of protection in surface shelters.* This type of shelter is subject to the full force of the drag loading resulting from the blast effect of a nuclear explosion. Such loading can be critical at relatively low overpressures particularly if there are openings above the surface. Streamlining the silhouette with earth cover will reduce the drag load. The protection from tree blow-down in the event a tree fell on the shelter would depend on the construction of the shelter.
- (6) *Loss of protection in subsurface shelters.* Since this type of shelter is underground, it is not subject to the drag-loading of the blast effect and can withstand higher blast overpressure than surface shelters. The effect of blast on the overhead cover of a subsurface shelter is essentially the same as that described in (4) above for covered emplacements.

17. Protection From Nuclear Radiation

a. *General.* The nuclear radiation effects of a nuclear weapon act only on the personnel within an emplacement or shelter and have no effect on the emplacement itself.

b. *Types of Nuclear Radiation Against Which Protection Is Required.*

- (1) *Initial.* Initial radiation consists essentially of initial gamma radiation, and initial neutron radiation.
- (2) *Residual.* Residual radiation consists of induced radiation and fallout.

c. *Initial Nuclear Radiation.*

(1) *Initial gamma radiation.*

(a) *General.* The gamma radiation which is produced by a nuclear explosion during the first minute after the burst is known as initial gamma radiation. This radiation is not capable of being detected by the human senses, but it is capable of producing casualties if personnel are not shielded from it. Distance is the best shielding factor, since the intensity of the gamma radiation decreases with the distance away from the source. Gamma radiation is also absorbed (or attenuated) to some extent when it must pass through any material. It is not possible to absorb gamma radiation completely, but if a sufficient thickness of material is placed between the source of gamma radiation and an individual the radiation dose received by the individual becomes negligible.

(b) *Protection afforded by emplacements and shelters.* The gamma radiation affecting occupants of emplacements and shelters is in two components (fig. 1). The direct or line of sight radiation, and the scatter radiation. At distances at which personnel in emplacements may be expected to survive

a nuclear burst, at least 50 percent of the incident gamma dose will be from the scatter component. This percentage increases with the range, so that for bursts of 10 KT or higher, on an emplacement or shelter in which personnel may be expected to survive, an average of 75 percent of the gamma dose will be from scatter radiation. An emplacement or shelter, such as a deep foxhole, which provides all-round shielding for the occupant against scatter radiation, but which may allow direct radiation (such as that from a high air burst) to enter, provides better overall protection than an emplacement or shelter which provides complete protection from direct radiation but does not provide all-round protection against scatter radiation.

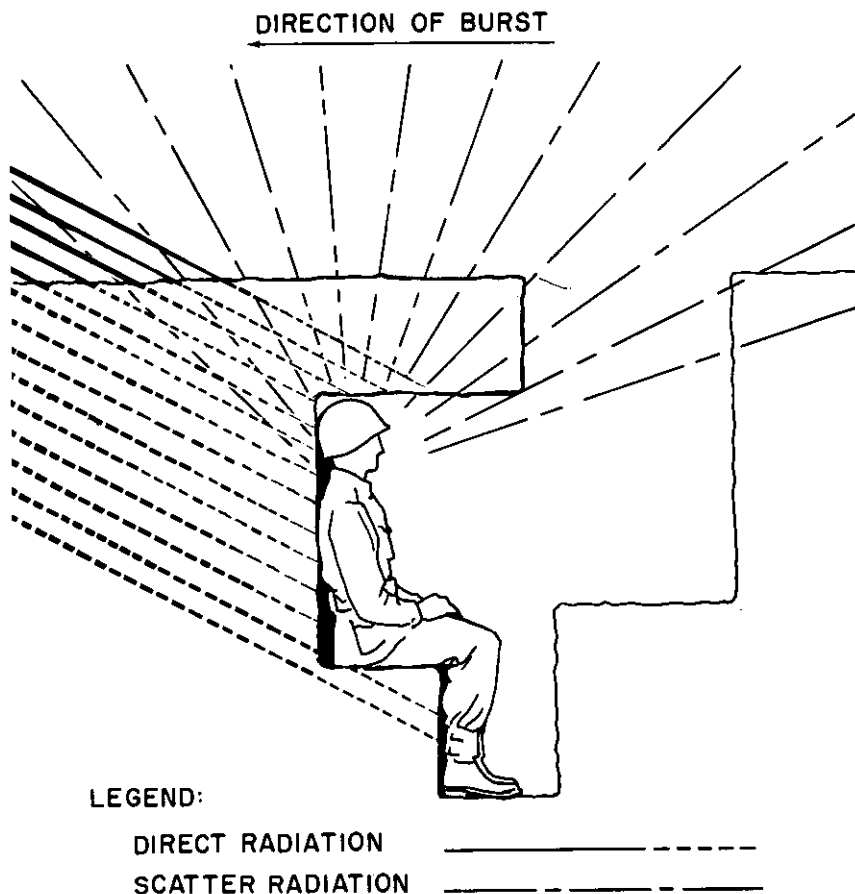

Figure 1. Effect of gamma radiation from a low air burst on occupant of an open emplacement.

(2) *Neutron radiation.* Neutrons produced by the explosion of nuclear weapons behave somewhat like gamma rays. Neutrons scatter more than gamma rays, as a result, emplacements and shelters with openings allow a greater percentage of neutrons than gamma rays to enter. Earth, however, provides better shielding from neutrons than from gamma rays with the result that a well baffled entrance to an emplacement or shelter reduces the percentage of neutrons to gamma rays which enter the structure. Properly constructed emplacements and shelters provide substantial protection against neutron radiation.

d. Residual Radiation.

(1) *Neutron induced gamma radiation.* This gamma radiation results from radioactivity produced in certain types of soil by neutrons produced during the nuclear explosion and exists in a circular pattern around ground zero. It exists primarily in the ground area directly below low air bursts. Personnel in emplacements or shelters in an area which is subjected to significant intensities of this type of residual radiation will probably have become casualties from other effects. Areas in which fortifications are to be constructed should be monitored to detect the presence of radiation if there are indications that the area was near the ground zero of a nuclear burst.

(2) *Fallout.*

(a) *General.* The radioactive dust and debris particles which fall back to the ground (fallout) from surface or near surface bursts present the most difficult residual radiation protection problem. Personnel in emplacements and shelters in fallout areas are subjected to radiation from two major sources. One is the scatter gamma radiation from radioactive particles in the surrounding (out to several hundred feet) fallout areas; the second is the direct gamma radiation from radioactive particles which fall or drift into or on the overhead cover of the emplacement or shelter.

(b) *Protection afforded by emplacements and shelters.* Emplacements and shelters protect against scattered gamma radiation as described in *c(1)(b)* above. Protection against radiation from radioactive particles (fallout) is obtained by keeping them out of the fortification itself and by providing a thick overhead cover to attenuate the radiation from any particles which do fall on or near the emplacement or shelter.

(c) *Permanent overhead cover.* While earth or other thick overhead cover on an emplacement or shelter will attenuate radiation resulting from any fallout deposited on it, the

overhead cover may be of such a design that fallout particles driven by the wind tend to collect above the shelter and actually increase the intensity of the radiation within the shelter. An emplacement or shelter should be constructed so that drifting as well as falling particles will not be concentrated in or near it. The use of a small ditch or berm approximately a foot away from the edge of an emplacement or shelter to intercept or collect wind-driven particles often substantially decreases the amount of radiation to which the occupants are subjected.

- (d) *Temporary overhead cover.* When a poncho, shelter half, or other temporary overhead cover is used to exclude fallout from an open emplacement the particles which collect on the temporary overhead cover should be periodically disposed of well away from the emplacement so that they do not reenter the emplacement before the overhead cover is replaced. This type of overhead cover *only excludes* the particles and does not attenuate radiation from them.

18. Protection From Thermal Radiation

a. *General.* The protection of personnel from burns resulting from direct exposure to thermal radiation is a problem of large proportions due to the great range to which this effect extends for the higher yield weapons. The task of protection is increased by the fact that casualties may also be caused indirectly as a result of fires in forest and built-up areas. Under certain circumstances (dry weather, forests subject to easy ignition, and high winds) the overall threat from the direct and indirect results of this effect may exceed that of all other effects, except fallout, combined.

b. *Protection From Primary Effects.* Thermal radiation causes direct casualties only on persons in the line of sight of the source of the thermal radiation. Personnel in the open or in uncovered emplacements can be provided some protection by any type of opaque shield, including protective clothing. All areas of the skin must be covered by the protective clothing. An emplacement or shelter which affords significant protection from nuclear radiation will normally provide protection from direct thermal radiation.

c. *Protection From Secondary Effects.* Fires in forests and built-up areas may result from direct thermal radiation. Protection against them is usually beyond the capability of the individual and is discussed in chapter 5 on the protection of units. Individual emplacements and shelters will normally give their occupants adequate insulation from the heat of the fire but cannot prevent suffocation over extended periods. Personnel in tanks and armored personnel carriers would be shielded from the fire provided they are able to receive sufficient oxygen

and the vehicle itself did not catch fire. If time or other considerations do not permit a quick evacuation from the fire area, personnel in vehicles should dismount and seek shelter in emplacements or shelters which have provision for ventilation.

Section IV. COMPARISON OF PROTECTION REQUIRED

19. Comparison of Protection Required From Different Effects of Nuclear Weapons

An interrelation exists between certain effects of nuclear weapons which governs the type and amount of protection from each effect which is required to provide the desired level of overall protection. The effects for which this interrelation is particularly significant are blast and prompt nuclear radiation. Protection from each of these effects must be balanced since no real protection is afforded by revetting an open fox hole in which the occupants will receive 5,000 to 10,000 rem of prompt nuclear radiation before failure of unrevetted foxhole walls would occur. The occupant will become a casualty whether the foxhole is revetted or not. Likewise, no real protection is afforded by providing an extremely low transmission factor for an emplacement or shelter which is not built to withstand the level of blast over pressure which would accompany the intensities of radiation capable of being withstood. The ideal emplacement or shelter is one which provides comparable degrees of protection for its occupants against the effects of blast and initial nuclear radiation at the ranges at which casualties would occur to personnel inside it. This balanced protection cannot be achieved precisely because changes in weapon yield and type result in changes in the relationship between the casualty radius from nuclear radiation and from blast effects. As a general rule, protection from prompt radiation is more important in low air bursts of small yield weapons and protection from blast is more important in high yield weapons.

20. Comparison of Protection Required From the Effects of Nuclear, Conventional, Chemical, and Biological Weapons

There are similarities between the protection which is required from each of these types of weapons. These similarities aid greatly in the employment of a single emplacement or shelter to provide balanced protection.

a. Protection is provided from the blast effect of nuclear weapons by the use of defilade or by the use of low streamlined silhouettes and strong construction. This includes protection from damage to individual fortifications from tree blowdown. These same measures are used to provide protection from direct fire artillery and small arms weapons and from low level aircraft strafing and rocket attacks. With respect to

type of construction, protection from the blast effect of a nuclear weapon requires strength, mass, and streamlining. Protection from direct fire weapons requires both strength and considerable thickness of relatively impenetrable materials. The requirements for protection from both the blast effect of a nuclear explosion and conventional direct fire must be considered in employing an above ground emplacement or shelter. The blast effect of the nuclear weapon generally governs the structural strength and shape; and the penetration by direct fire weapons governs the thickness and composition of protective shielding.

b. The requirements for protection from nuclear radiation are similar to requirements for protection from fragments from indirect fire artillery and bombs, as well as some types of air delivered weapons. Basically, both require a minimum diameter, maximum depth and excavation in defilade, and overhead cover with a minimum of aperture or entrance area, and baffles in entranceways wherever possible. Generally, protection from conventional weapons will establish a requirement for minimum desirable thickness of cover. Protection from nuclear radiation will, in most cases, govern the required thickness above this. Depending on materials available and assuming good construction, about 12 to 24 inches of overhead cover will normally protect from shell fragments. Eighteen inches of earth over half a foxhole will reduce the total gamma radiation dose from a low air burst to about 0.7 of its value on an open foxhole. This decreases the distance from ground zero at which the occupant of the foxhole would be safe by about 100 yards. Changing the thickness of the half cover to 12 or 24 inches of a cover would not change this distance appreciably. Thus thickness of partial overhead cover should normally be based on protection from conventional weapons. When full cover is used, however, and there is little or no line of sight access of radiation into the shelter, radiation attenuation outweighs conventional weapons effects in governing the thickness of earth cover. In such a case for example, a change from 12 to 24 inches of earth cover can be expected to reduce by more than half the initial nuclear radiation dose received by the occupant.

c. A fortification providing good protection initial radiation will usually provide excellent protection from fallout radiation if steps are taken to exclude the fallout particles.

d. Fortification characteristics required for the exclusion of chemical agents (casualty gases and flame) and biological agents will also exclude fallout particles.

CHAPTER 4

PROTECTION OF CREW SERVED WEAPONS, COMBAT EQUIPMENT, AND MATERIEL

21. General

This chapter covers the fundamentals of protecting both infantry and artillery crew served weapons (excluding missiles) and the combat equipment and materiel normally found in the combat zone.

22. Protection Required

In considering the protection of personnel, definite radiation levels, blast pressures, or conventional weapon effects could be taken as criteria since all personnel would be affected similarly under given conditions. However, when considering the requirements for protecting weapons, equipment and materiel, each effect of conventional and nuclear weapons must be considered with respect to the type of weapon, equipment and materiel to be protected.

a. Protection From Conventional Weapons Effects. Most weapons, equipment, and material are vulnerable to three conventional weapons effects—the blast of a direct hit, or very near miss, of shells and bombs; cutting and tearing by projectiles or bomb and shell fragments; and burning by incendiaries. Emplacements generally provide good protection against these effects. Especially sensitive materiel may require greater protection from blast and shock than that given to personnel. Weapons and equipment are susceptible to damage by fragments in varying degrees depending on the extent to which the item is armored. The effort required to construct overhead cover for supply and equipment trenches is usually not justified by the added protection value it affords. Incendiaries will destroy or damage nearly all materiel. Some materiel, such as food, water, and medicine can be contaminated by gas if not sealed in airtight containers.

b. Protection From Nuclear Weapons.

- (1) *Protection from blast.* Blast can cause damage by the crushing effects of high overpressure, by causing exposed objects to be translated as a result of drag loading or by striking material with blast driven debris. Against materiel, as against personnel, the effects of drag are usually much more significant than overpressure itself. Whenever possible, weapons, equipment and materiel should be placed so as to reduce or eliminate drag. Normally, this requires placing them below the ground

surface, which gives some protection from flying debris or falling trees. Certain materiel such as fragile supplies and airtight containers are vulnerable not only to drag but to overpressure as well. For these items pressure resistant shelters will provide some protection.

- (2) *Protection from nuclear radiation.* With two exceptions, nuclear radiation causes no damage to materiel. The minor exception is food and medicine, which are not harmed by high radiation doses, but in which the color and taste may change. The major exception is electronic equipment, particularly transistorized components, which can be permanently damaged by neutron radiation. If it is necessary to protect materiel from initial radiation, it should be shielded in the same manner as personnel. Residual radiation can render supplies and equipment unsafe to handle until they are decontaminated. Protection from fallout may be provided by placing a cover such as a tarpaulin over the materiel. When the cover is removed carefully, most of the fallout particles will be removed with it.
- (3) *Protection from thermal radiation.* Thermal radiation affects anything that will burn. Any flame resistant cover will provide protection depending on the intensity of the heat. A few inches of earth provides excellent protection. Thermal energy levels required to ignite various materials in the open are listed in DA Pam 39-3.

CHAPTER 5

PROTECTION OF UNITS

23. Protection By the Use of Mobility

Mobility is an operational means of protection from the effects of nuclear weapons. It permits a unit to locate at an area other than one subject to attack. Mobility does not reduce the necessity for physical protection, though it does tend to govern its nature and type. Physical protection should be developed to facilitate mobility. Frequent movement limits a unit to those levels of field protection most rapidly attainable with the least logistic effort. A less mobile unit uses more substantial fortifications in fewer locations. The total amount of effort required to achieve both kinds of protection may well be the same. The following general factors, described in *a* through *f* below, affect the use of mobility and in doing so, directly affect the levels of protection available to a unit.

a. The Effect of the Unit's Mission on the Protection Afforded by Mobility. The first step in analyzing the requirements for protection of a unit is to consider its mission. In both offensive and defensive operations the requirements of its mission may prevent a unit from using mobility as a means of protection. When the mobility of a unit is restricted by its mission, use of maximum possible dispersion and physical protection must be emphasized to the maximum extent compatible with the mission. Capability for protection and the manner in which emplacement and shelters are integrated with the requirements of mobility are directly related to the type of unit and its mission.

b. Capability for Movement. A primary consideration with respect to use of mobility as a means of unit protection is the mechanical ability of the unit to move and keep moving. This consideration applies in offensive as well as defensive operations.

- (1) *Ability to move.* This depends on the unit's ability to maintain and fuel its means of transportation. How fast the unit can move, with what degree of concealment or effective camouflage it can move, and its limitations in respect to where it can move, are all factors in the degree of protection afforded the unit by mobility.
- (2) *Ability to keep moving.* This is the unit's capability for overcoming obstacles to movement: tree blowdown, mass destruction of built-up area, widespread mass fires, large radioactive craters created by nuclear weapons, and areas of intense fall-

out are obstacles to movement. In addition to the created obstacles, the natural conditions of the geographic area have a major governing effect on mobility. These limitations affect foot soldiers, ground vehicles, and aircraft. If a unit is not able to move or keep moving, shelter must be provided for those not protected by the means of transport, and for the means of transport itself. The extent to which the mobility is limited influences the types and levels of protection required.

c. Integration of the Protection Afforded by Mobility With That Afforded by Physical Protection. High mobility is an essential characteristic for units involved in nuclear warfare. In itself, however, it does not always serve as a means of protection. A unit in place and well camouflaged is much less likely to be observed (and consequently attacked by nuclear weapons) than a unit which is moving. A moving unit has no physical protection from the effects of nuclear weapons other than its organic vehicles. For small units and those which do not appear to constitute a profitable nuclear target, their mobility may allow them to escape observation and subsequent attack. For other units, mobility offers no inherent protection unless the unit can escape enemy observation except for periods too short to allow accurate delivery of nuclear weapons. A unit in place can dig in and greatly reduce its possible casualties from a nuclear weapons attack. Even with the limited time available on offensive operations, significant increases in protection can be obtained by digging in. On the other hand, a unit which has been observed in an area and determined to be a profitable target for nuclear attack can, by moving out of the area (if such movement can be accomplished prior to the attack and is undetected) completely escape the effects of the enemy nuclear attack. The selection of the best course of action in a given situation, i.e., movement or digging, is a command decision which depends, among other things, upon the observation capabilities of the enemy, the size, type, location and mission of the unit, the enemy reaction time, the availability of a suitable area for relocating the unit, and the capabilities of the enemy for employing nuclear weapons. In warfare when nuclear plenty exists, the enemy may be able to saturate on short notice an entire area in which he has detected significant movement. In such a situation, the development of a high degree of physical protection will normally provide a maximum reduction in casualties from enemy nuclear attack.

d. Effect of Available Area on Mobility. For the same level of protection from a given nuclear weapon, a well dug in unit can gain physical protection using only $\frac{1}{4}$ to $\frac{1}{2}$ the area required if it were merely dispersed in the open. This is quite important in offensive operations where it is necessary to use enough troops to create a preponderance of force. Wherever such troops cannot continue moving

either as a result of the dictates of the mission or of enemy action, they must place a high priority on attainment of maximum possible physical protection. To derive added protection from a move, a unit requires a suitable area in which to move. This new area must be one which permits the unit to accomplish its mission. It should not be one just vacated by another unit. If units continually exchange positions they merely invite attack, since it makes little difference to the enemy which one of the units occupying a position over a period of time is destroyed. Time spent on movement which merely exchanges unit positions, is better spent in improving the physical protection in each area with movement deferred until it is actually required for the mission. Considering the degree of dispersion which is essential in modern warfare, suitable areas to which a unit may move will usually be at a premium, except in extended advances. As a result, the use of fortifications which reduce the area required by a unit for adequate dispersion increase the opportunities for movement.

e. Type of Unit and the Individual Protection Organically Available. The type of unit and the protection organically available to the unit without the use of emplacements or shelters usually determines the degree to which the unit will use emplacement and shelters in conjunction with mobility. A reconnaissance unit which moves rapidly in small increments and does not appear to be a profitable nuclear target can move with relative safety but needs physical protection when tactical or logistical requirements require a halt. On the other hand, an armored unit is generally safer in medium tanks than in open foxholes. Infantry in armored personnel carriers are safer than in prone shelters. Such units do not normally require emplacements and shelters for their personnel assigned to tanks or armored carriers unless they, for tactical or logistical reasons, are going to remain in one place for a period of time sufficient to permit developments of emplacements and shelters affording considerably more protection than the vehicles themselves. Personnel of the unit who do not have the protection afforded by the vehicles should develop other protection as rapidly as possible to a degree matching that available for the rest of the unit. Many units have supporting units which must be well protected if the supported unit is to remain effective. Most combat support and service units have little organic physical protection and for this must rely almost exclusively on digging in regardless of the type of operation being supported.

f. The Logistical Situation and Its Effect on Mobility. Logistical situations limit the protection afforded a unit by mobility. Units which are capable of providing protection for themselves by mobility and which in fact can base their means of protection on their ability to move are still limited because of their dependence on logistics systems which must remain relatively immobile.

24. Protection by the Use of Dispersion

a. General. Dispersion is a primary means of increasing protection of units from the effects of nuclear weapons. In effect, doubling the size of the area occupied by a unit will reduce by half the number of casualties the unit will receive from a given nuclear burst, if the original area occupied by the unit is at least as large as the area over which the casualty producing effects from the burst extend. This increase in protection is comparable to that provided by providing an unprotected unit, in place, with fortifications having an average Fortification Protection Factor of 50 (app. II). The amount of dispersion used depends upon the size and capabilities of a unit, its mission, the available area and its characteristics, enemy capabilities, and the ability of the unit to dig itself in. Fortifications, properly employed, can be used in lieu of or to supplement dispersion. Such employment of fortifications can be particularly important for those units, which after considering the factors listed above, cannot disperse sufficiently to obtain adequate protection. Conversely, the proper use of dispersion can greatly reduce the requirements for unduly high levels of protection using field fortifications.

b. Superimposition. In many situations there will be areas in which there is not sufficient space, even with the use of field fortifications, for units to disperse satisfactorily, each in its own area, without attempting to attain unduly high levels of physical protection. A method of compensating for this shortage of space is the use of the technique of superimposition. In applying this technique, unlike subunits are stationed close together and like subunits are well separated. By this means a command can insure that a given nuclear attack cannot entirely eliminate a specific capability of the command. For example, in one area there could be an engineer construction company, an ordnance company, a field artillery service battery, and a signal construction company. In an adjacent area, with units of similar types sufficiently distant from each other so that one nuclear weapon could not destroy two units of the same type, there could be another engineer topo company, another field artillery service battery, and a military police company. Losses would then be balanced, with less serious overall effect. This superimposition eliminates the necessity for excessively high levels of protection demanding high troop and logistical effort. This same technique may be applied to the superimposition of larger units. There is, however, this important limitation on the use of superimposition. A unit of a type having a high probability of attracting a nuclear attack or dummy or decoy units designed to attract fire should not be placed in the vicinity of other units.

25. Balancing Means of Protection

In order to obtain maximum protection for a minimum of troop and

logistic effort expended on physical protection, it is necessary to achieve a balance between physical protection, dispersion and mobility. To be able to use mobility effectively for protection of appropriate units, suitable unoccupied areas must be available into which these units can move. To accomplish an assigned mission a certain troop strength must be put in an area. The troop capacity of the available area can be expanded without increased risk of loss to nuclear attack by the proper use of field fortifications. The degree to which the available area can be expanded is in general inversely proportional to the overall Fortification Protection Factor of the fortifications or other means used. Where the combination of dispersion and a reasonable degree of physical protection does not result in the required degree of protection in the available area, superimposition, as described in paragraph 24*b*, can be used to insure that no essential capability of the command is subjected to unacceptable losses from a given attack, although the total loss to the command may exceed normally acceptable limits.

26. Organization of the Ground

a. The defense is built around a series of organized and occupied tactical positions which are selected for their natural defensive strength, their contribution to the unit's mission, and for the degree of observation available. Unit-construction field fortifications, adapted to the fire plan for organic and supporting weapons, are used to strengthen these positions. The plans for these fortifications not only must provide for the desired degree of protection but also for bringing the enemy under the maximum volume of effective fire as early as possible. In almost all situations, plans are based on progressive construction, proceeding from open to covered emplacements and shelters, then on to the ultimate protection which it is reasonable to provide in the given circumstances. As soon as a unit moves into position anywhere in a theater of operations, it must at least provide itself the minimum protection against the effects of nuclear weapons, since it must always be assumed that the enemy possesses the capability of employing nuclear weapons.

b. In the offense, movement is continued until enemy action or over-extension of our own capabilities forces a halt. At such times a unit is particularly vulnerable to enemy counterattack action and the unit should acquire the maximum possible protection as rapidly as it can. In gaining such protection however, it must be careful that it does not compromise capabilities for future movement.

CHAPTER 6

PROTECTION OF ADMINISTRATIVE SUPPORT INSTALLATIONS

27. General

Administrative support installations represent a major protection problem. Administrative support installations include facilities such as depots, maintenance centers, hospitals, and replacement centers. To provide these installations with a high level of protection by means of emplacement and shelter construction alone is prohibitively expensive except under very special circumstances. Other means must be used which reduce the fortification and shelter effort to within reasonable limits. Dispersal reduces vulnerability considerably. Effective dispersal of unprotected installations, however, introduces major problems: efficiency, security, and control capabilities are greatly reduced. Engineer effort may still be prohibitive because of the extended road (and to the rear, rail) nets required, and because of the demand to build in the dispersal areas additional facilities considered essential by the various technical services. The total area required to provide adequate protection through dispersal alone can be prohibitive. This chapter is devoted to means which can be taken to provide maximum possible protection of administrative support installations without introducing excessive requirements for emplacement and shelter construction effort, and without requiring excessive dispersal.

a. Protection Objective. The basic objective of protection for an administrative support installation is to insure a continued capability to accomplish its assigned mission after a nuclear attack. This requires preservation of personnel essential to accomplishment of the mission and preservation of essential stored and operating supplies and equipment.

b. Factors Involved. There are many factors involved in providing installation protection. Some of them affect the levels of fortifications required more directly than others. This manual discusses in detail only those considerations arising from those factors which directly affect field fortification design and the engineer effort (by engineer or nonengineer units) required to provide adequate protection.

(1) The factors involved are—

(a) The proportion of a given type of supply or activity which a command can afford to lose to one nuclear weapon. This

involves stockage and reserve levels, resupply capabilities, and other similar considerations.

- (b) The maximum size of weapon which the enemy can deliver upon the administrative support installations of a command.
 - (c) The number of separate locations for installations which can be utilized considering available area, facilities, and transportation network, operating efficiency of installations, local security problems, and other types of units in the area.
 - (d) The size of the total area over which a given installation can operate adequately, and the amount of this total area which must be physically occupied.
- (2) From these general factors are drawn the following specific requirements for each installation affecting field fortifications design.
- (a) The proportion of the supplies or activities in a specific installation which is the maximum which one nuclear burst can be permitted to destroy.
 - (b) The distance which must be maintained between those portions of the installation which are not to be destroyed by a single nuclear burst for different levels of field fortifications construction.
 - (c) The total area through which the installation can be dispersed, the amount of this area which must be physically occupied, and the facilities within the area which must be utilized.

c. Protective Layout of Installations. To provide maximum protection with minimum effort, utilizing the factors just described, the layout of an installation must be planned in conjunction with the fortifications and shelters designed to provide the desired level of protection. Layouts can be planned for any specific size of nuclear weapon, degree of physical protection, and existing available area so as to provide that a given proportion of any type of supply facilities, or personnel will survive the burst of one nuclear weapon. This layout may often bear a resemblance to or be coordinated with the superimposition of units discussed in paragraph 30e. In considering the layout of installations, four different types of installations will be considered.

- (1) *Undispersed.* These are installations which are small enough or of a nature such that dispersal of the components of the installation into subinstallation areas is not desirable, even though it is recognized that the entire installation may be lost to one nuclear weapon.
- (2) *Linearly Dispersed.* These are installations which are of a nature facilitating linear layout and which contain supplies or facilities which the command cannot afford to lose in their entirety to one nuclear burst. Linearly dispersed installations

are long narrow installations, (usually along road nets) which can be long enough that the combination of layout and physical protection will permit one or more portions of the installation to remain intact when a nuclear weapon destroys some other portion of the installation.

- (3) *Point dispersed.* These are installations which can operate in more than one local area in the same vicinity, which contain supplies or facilities which the command cannot afford to lose in their entirety to one nuclear burst, and which have small operating area requirements. Such an installation consists of two or more small subinstallations at points separated from each other by distances dictated by the considerations discussed in paragraph 30.
- (4) *Area dispersed.* These are installations or groups of installations which can operate in more than one local area in the same vicinity, which contain supplies or facilities which the command cannot afford to lose in their entirety to one nuclear burst, and which have fairly large operating area requirements. Such an installation consists of two or more subinstallations in areas separated from each other by distances dictated by the considerations discussed in paragraph 31.

28. Undispersed Installations

The primary requirement for protection of an undispersed installation as described in paragraph 27c(1) is protection from fallout, except when the protection is intended to be of such a high level as to permit a significant probability that an enemy nuclear weapon aimed at the installation will miss far enough due to normal delivery error to leave the installation intact.

a. Protection Against Fallout. The essential requirement for protection against fallout is protection of personnel, but steps should be taken to facilitate ready decontamination of supplies and equipment, when radiation levels have decreased sufficiently to allow this. Personnel may be protected by field fortifications of the type listed in this manual, or by more elaborate structures, requiring greater engineer effort, as covered in engineer technical manuals. Normally, available time, supplies, and engineer effort will dictate use of field fortifications described in this manual. The fallout transmission factors with each fortification provide information on fallout protection. If shelter is desired, from within which operations may be continued while radiation intensities remain high, special design and engineer effort will normally be required. Such shelters are not included in this manual.

b. High Levels of Protection. For certain critical installations, especially those prepared prior to a war, a very high level of protection may be desired, so that these installations will provide a chance of survival from a large nuclear burst. Such shelters often involve use

survival from a large nuclear burst. Such shelters often involve use of existing deep underground cavities. They cannot normally be constructed using unit effort and are not included in this manual.

29. Linearly Dispersed Installations

a. General. One of the best ways to provide administrative support installations with protection from nuclear attacks is to lay out the installations generally in a straight line, paralleling a road system if possible. This layout is particularly useful for installations such as conventional ammunition supply points and depots. However, this disposition is not satisfactory for some administrative support installations because of resulting difficulties in installation operations and in providing security.

b. Coordination of Layout and Physical Protection. One of the characteristics of linearly dispersed installations as described in paragraph 27c(2) is that a specified proportion of the installation must survive an attack by a single nuclear weapon of a given size. For completely unprotected personnel and materiel subject to attack by weapons of megaton yield, the distances required between portions of an installation to insure that no more than one portion will be destroyed by one nuclear weapon are often prohibitive. Proper use of field fortifications can greatly reduce these distances. In addition, location of existing facilities may govern the location of portions of the installation, preventing the use of arbitrary separation distances. In laying out a linear installation, the level of shelter provided can be varied with the distance between like components of the installation to insure that one of these components will survive a nuclear burst of given size; or the reverse process can be followed in which the distance between like components of the installation can be varied according to the shelter provided to insure the survival of one component of the installation from an attack by the given size nuclear burst. The inter-relationship of the shelter and separation distance is illustrated in appendix III. In this appendix a linearly dispersed installation is described in which $\frac{2}{3}$ of the materiel and personnel are to survive a one megaton burst. Without any shelters or fortifications the installation must be 17 miles long to fulfill the requirements. Using fairly simple personnel shelters it can be reduced to 10 miles long. Using better personnel shelters and open trenches to protect materiel, it can be reduced to 8 miles long, and still provide for $\frac{2}{3}$ survival from a one megaton burst.

c. Fallout Protection. Normally, shelters provided for protection of personnel from initial effects will provide adequate fallout protection. The discussion in paragraph 28a on fallout protection for undispersed installation applies here also.

d. Camouflage. Certain characteristics of a linear installation facilitate its camouflage. If the installation is disposed along a large and

active road net, normal activity on the road will detract from the activity of the installation, so far as revealing the position and the nature of the installation is concerned.

30. Point Dispersed Installations

a. General. An alternative to the linear installation layout is dispersion of subinstallations about a central point. For small installations, this takes the form of dispersal of points at a few chosen locations. The advantage of such dispersion is that all the dispersed subinstallations can use common facilities at the center.

b. Coordination of Layout and Physical Protection.

- (1) For layout of a small installation in several dispersed points, there should be chosen, based on enemy capabilities, a size of weapon from which a definite proportion of supplies and personnel must be protected. The critical effect radius of this design weapon is matched against the critical item to be protected, and the points are dispersed so that an adequate distance will separate each point from the next. The effect of field fortifications in reducing this distance, and the corresponding effort involved for various levels of protection can be calculated as shown in appendix III.
- (2) Assuming an installation dispersed in what is essentially a three point pattern, a design weapon 200 KT and a maximum allowable loss of one-third of the total installation, each point should be 4 miles from the next if the personnel are unprotected. If the personnel are protected by simple field fortifications to a level corresponding to the blast resistance of the supplies, this distance may be reduced to 2.5 miles. If both the personnel and supplies are protected by covered shelters and supply trenches, so that blast resistance up to 25 psi can be expected, and so that the personnel in their shelters have radiation protection comparable to 25 psi blast resistance, the distance can be further reduced to 1.9 miles.

c. Fallout Protection. Normally shelters providing protection for personnel from initial effects will provide adequate fallout protection. Refer to paragraph 31a which applies to any administrative support installation.

d. Camouflage. The small area physically occupied by the few points comprising the point dispersed installation makes the problem of camouflage relatively simple. The points may be shifted to the most easily camouflaged sites, as long as the required minimum distance between points is maintained and the sites selected will allow efficient operation.

e. Superimposition. The point dispersed installation, because of the relatively small area physically occupied, is readily adaptable to having other units superimposed upon its overall area. This facilitates

security but adds to the problem of camouflage of the entire area. The area as a whole will become a more lucrative nuclear target as more units are added to it, but if each unit properly disposes itself and digs in appropriately, no one unit capable of dispersion should be rendered ineffective by one nuclear burst.

31. Area Dispersed Installations

a. General. When an installation has so many components, or must physically occupy so large an area that these components cannot be efficiently dispersed either linearly or as a separated group of points, the various components may be grouped as subinstallations located in a wide band about a central point. Such a pattern is more suitable for a rear area complex whose parts utilize common facilities than it is for smaller combat area installations which do not physically occupy a large area. The band of subinstallations resembles a "doughnut" whose inner area is large enough to include the damaging effects of a specified size weapon. The outer radius is sufficiently larger than the inner radius to provide operating space for the component units of the installation. The use of trenches, shelters and emplacements can reduce both the inner radius and the outer radius, and by thus decreasing the overall area can improve intrainstallation coordination.

b. Layout.

- (1) The activities of the installation should be dispersed throughout the operating zone, so that the center of each subinstallation may be separated sufficiently from the next to insure survival of the required proportion of the total installation after a burst of a specified weapon on the worst possible spot. Like activities must be separated by a distance equal to twice the radius of the critical effect. Activities which are most vulnerable should be placed at the outer edge of the operating zone.
- (2) The central area of the "doughnut" may be used to facilitate intrainstallation coordination over its road network, to store surplus or salvage items, and for the location of those activities whose survival is less essential, or which have a particularly low vulnerability to weapons effects.
- (3) Since like activities must be separated if possible, it follows that each subinstallation will contain a variety of activities. Thus a maintenance company may be divided into three widely separated platoons, if it is capable of operating when so divided. The accompanying loss in efficiency must be weighed against the protection gained by dispersal.

c. Physical Protection. In such an installation, the various supplies and equipment and the personnel will be affected differently by different levels of weapons effects. Field fortifications should be designed to bring the more vulnerable items up to the level of hardness of the

more resistant items. Critical items should receive priority for protection. The extent to which an activity can be hardened by shelters and emplacements will directly affect where the activity should be placed in the installation. Digging in an activity which requires a large operating area may require considerable effort and reduce the operating efficiency, but this digging in will allow a decrease in distance between components, which may offset the loss in efficiency. Since a rear area installation will normally stay in place for a comparatively long time, the planned layout should include the use of field fortifications throughout the installation. The effect of combining dispersion and digging in is shown in the example in *d* below.

d. Example of an Area Dispersed Installation. Assume a weapon of 5 megaton yield as the weapon from which three-fourths of a total installation must survive, and activities in the installation which range in resistance from that offered by shelters and equipment trenches (25 psi) to that offered by foxholes and supplies in the open (15 psi). Such an installation, divided into four large subinstallations, may be safely placed in a band whose inner diameter is no less than 10,800 meters and whose outer diameter is 16,500 meters. The activities closest to the center are those least vulnerable or most expendable. If the personnel were mostly in the open, the inner diameter would be about 26,000 meters. The outer diameter would have to be 30,000 meters to insure that a burst between two subinstallations will not destroy the greater part of both. The advantage gained by use of relatively light field fortifications is obvious. Refer to appendix III for detailed calculations.

e. Fallout. An area dispersed installation is large enough so that protection from fallout can depend on location of the various activities within the whole installation. The direction of the prevailing winds can be determined, and if a nuclear burst is most probable in the center of the installation, those activities which would be most impeded by fallout should be placed upwind of the center. The shelters shown in this manual will provide adequate protection from fallout.

f. Camouflage. The large amount of area physically occupied by some logistic installations makes camouflage difficult. On the other hand, the large amount of area available in the operating band of an area dispersed installation may offer considerable opportunity for selecting individual areas which possess considerable camouflage potential. In selecting such areas, the possibilities of tree blowdown and fires must be kept in mind.

g. Superimposition. Superimposition of activities and units is a prerequisite for an area dispersed installation. Each subinstallation contains a variety of dissimilar units which share common facilities and security. Without superimposition, the requirements for area would be impossible to fulfill.

PART THREE
MEANS OF PROVIDING PROTECTION
CHAPTER 7
GENERAL

Section I. MATERIALS AND METHODS

32. Materials

a. Natural. Full use is made of all available natural materials such as trees, logs, and brush in the construction of emplacements and shelters. In many types of terrain an area will contain sufficient natural materials to meet the requirements for revetted emplacements and those with light cover. Snow and ice may be used in the construction of emplacements and shelters in arctic areas.

b. Prepared.

- (1) Standard construction material such as dimensioned lumber, corrugated metal, sandbags, spikes, burlap, and woven wire are engineer class IV items of issue and are available at engineer supply points.
- (2) Captured enemy supplies, locally procured material, and demolished buildings may furnish good sources of expedient construction materials.

33. Excavation

a. Use of Hand Tools. The individual soldier may be equipped with intrenching tools, pickmattocks, shovels, intrenching axes or machetes. The relative value of each tool depends on the soil and terrain encountered. In arctic areas, a larger quantity of intrenching axes are required to aid in the preparation of emplacements in frozen ground. The infantry division battle group is authorized as part of its organizational equipment, an Intrenching Outfit, Infantry, consisting of 250 round pointed D-handled shovels, 125 pickmattocks, 500 sandbags, 200 pounds of nails and a supply of saws, axes, wire cutters and other hand tools. The man hours required to excavate the standard emplacements described in chapter 8 are shown in table V.

b. Use of Equipment. The relatively narrow cuts with steep or nearly vertical sides required for most emplacements or shelters can be accomplished more accurately by hand. However, ditching machines, back-hoes, and excavators are highly desirable for most applications because

of their speed in digging. Bulldozers and scrapers may be used for larger excavations. Often these machines cannot dig out the exact shape desired or must dig out more earth than is required. As a result, hand labor and additional revetment material are usually needed to finish up the excavation when machines are used. The use of construction machinery results in the creation of distinctive scars on the terrain and increases the effort required for effective camouflage.

c. Use of Explosives. Explosives may be necessary for excavation in rocky or frozen ground and may be desirable to aid hand labor in any type of ground. Personnel using explosives must be properly trained and qualified. The possible undesirability of noise must be considered in planning the use of explosives.

34. Connections and Framing

a. Connections. Wood connections are made by nailing, spiking, or bolting or by the use of driftpins. Expedient connections are made with wire or rope lashing or pipe dowels or by notching. In connections which depend upon direct bearing, wire lashings or similar fastenings are added wherever they will improve the initial strength and rigidity of the structure. Where a fastener must resist relative movement of the parts in contact, driftpins or scabs are used. When driftpins or bolts are used, holes should be drilled in the wood members to prevent splitting.

b. Framing. Frames to support overhead cover for emplacements and for shelter structures are usually constructed using post-cap-stringer type construction or post-cap and laminated roof construction. This type of construction is illustrated in figure 2. Structures framed using this type of construction require less materials than built-up structures using notched logs or dimensioned timber. The post-cap structure lends itself to prefabrication and has been used as the basis for the standard structures presented in chapters 8 and 9. Either logs or dimensioned timber can be used in this type of construction. In most of the joints used in this type of work there is direct compressive contact between the ends and sides of wooden members, and the strength of the joint does not entirely depend upon nails or driftpins except when the resultant load is directed upward by the buildup of pressure inside the shelters. Joints which are properly fitted and tightly assembled result in a structure which is stronger than one with poorly fitted joints in which the wood fibers are crushed at the few points of contact and the remainder of the bearing area serves no useful purpose. If logs are used as shown in figure 3, and the ends of log stringers rest on a log cap, the bottom of the stringer ends are flattened to fit the flattened top surface of the cap. This is done to increase the bearing area between the cap and stringer. The depth of the cut on stringers and caps should not exceed $1/6$ of the diameter of the stringer or cap logs.

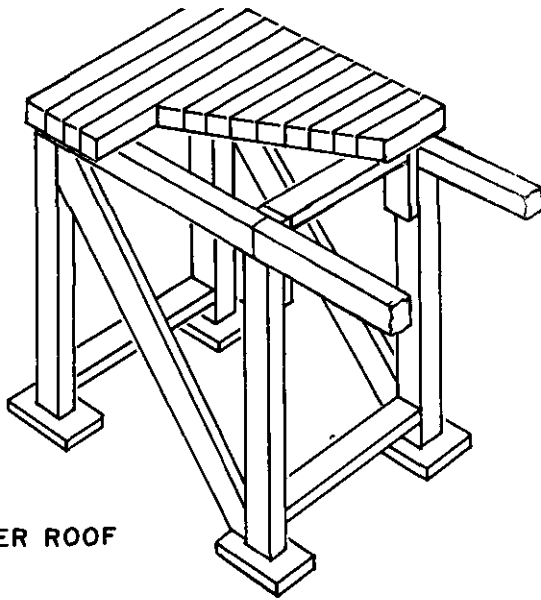

① STRINGER ROOF

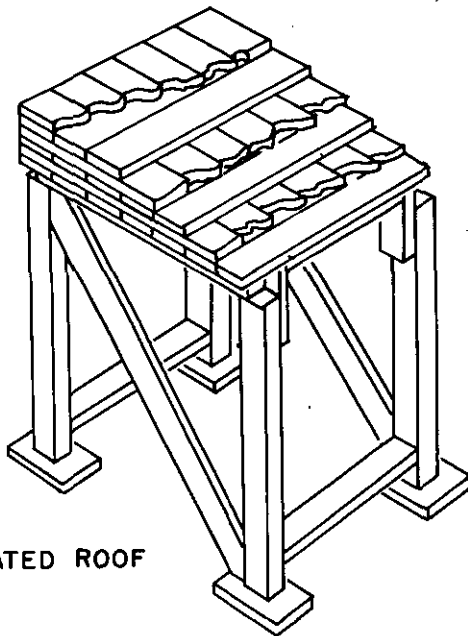

② LAMINATED ROOF

Figure 2. Post-cap-stringer construction using dimensioned timber.

When log caps are used, the portions of the cap which rest on the posts are flattened as shown in 1, figure 4 in order to provide a level bearing area and to reduce the possibility of splitting the post due to the concentrated load. As in the case of the stringer ends the amount removed

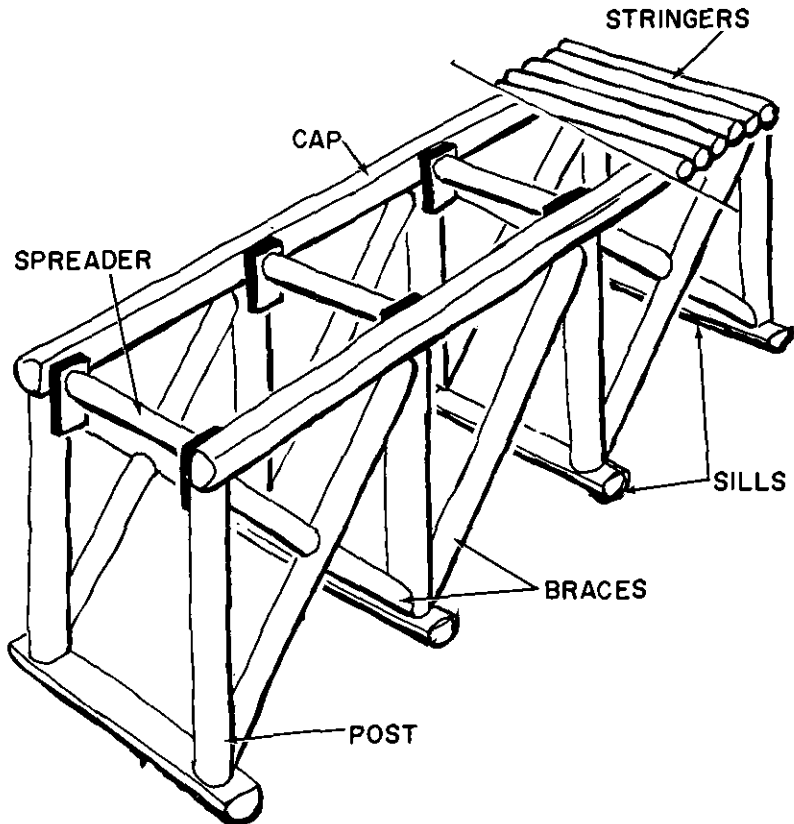

Figure 3. Post-cap-stringer construction using logs.

should not exceed $\frac{1}{8}$ of the diameter of the cap log. When it is not possible to flatten the cap where it rests on a post the post itself should be wrapped with 6 to 10 turns of heavy iron wire as shown in 2, figure 4. Salvaged communications wire may be used as an expedient wrapping.

c. Wall Construction. Walls used in emplacements or shelters may consist of sheathing (planks or corrugated metal) nailed over frames built as described in *b* above, or be built up using notched logs or dimensioned timber.

- (1) *True notched log method.* Walls may be constructed using logs or timbers notched as shown in 1, figure 5. This type of construction requires more material than post-cap-stringer construction and does not resist impact loads as well as post-cap-stringer construction.
- (2) *Modified notched log method.* A more desirable method of wall construction using notched logs or timber is the modified notched log method shown in 2, figure 5. Either logs or

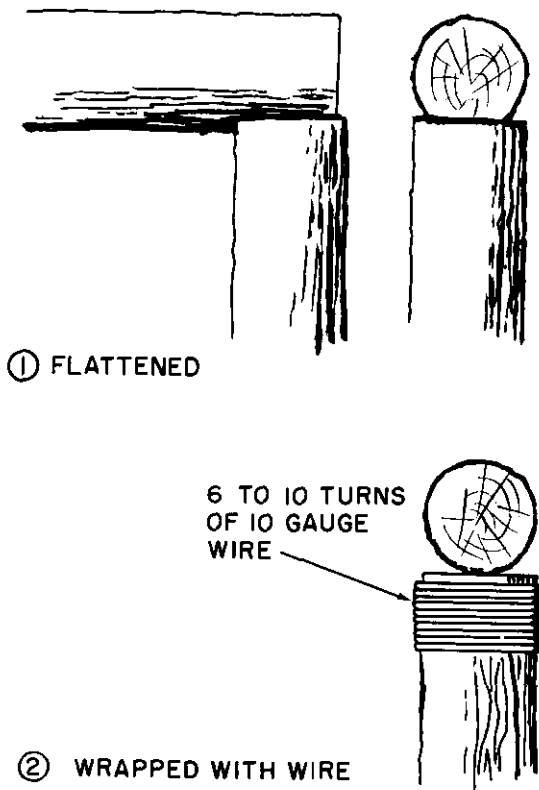
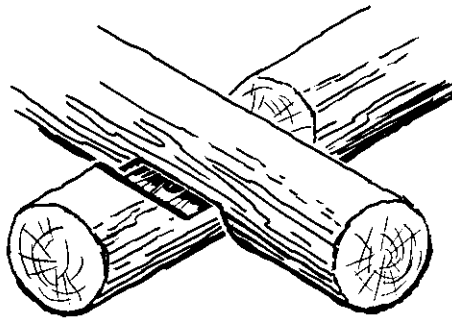

Figure 4. Use of log caps.

dimensioned timbers may be used in this method. Such a wall resists inward pressure but does not resist outward pressure. For subsurface structures this method of wall construction has an important advantage in that the structure has square corners and does not require excavating recesses for the ends of logs or timbers projecting beyond the notches.

- (3) *Precautions in notching.* Notching requires accuracy in layout and workmanship. Cuts are made by sawing wherever practicable. Overcutting in either direction, either with or across the grain causes weak points which may result in partial splitting or complete failure of the member. All joints in notched logs or timber are connected with driftpins for increased lateral stability.

d. Bracing. Frames may require bracing during or after erection. Standard methods of installing braces are shown in figure 6. The method illustrated in 1, figure 6 (external bracing) is usually used when timber frames are assembled above ground and lowered into place. Such



TRUE NOTCHED-LOG METHOD

①

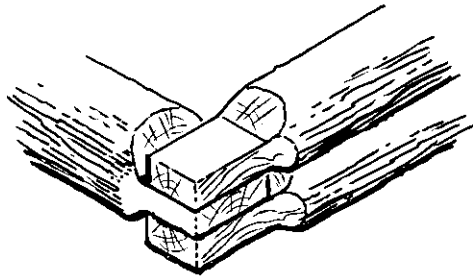

MODIFIED NOTCHED-LOG METHOD

②

Figure 5. Notched wall construction.

braces may be removed later if they present an obstruction provided sheathing or smaller internal bracing is used. This type of bracing has the advantage of preventing distortion in either direction. Its strength, however depends solely on the strength of the nailed or spiked joints and its method of installation does not permit the use of round logs. The methods of bracing illustrated in 2 and 3, figure 6 (internal bracing) are stronger because the entire end of the brace bears against the post or strut. These braces may be the full thickness of the post; single internal braces prevent distortion only in one direction. In a series of sidewall frames, the disadvantage can be compensated for by alternating the direction of the brace in adjacent frames as shown in 4, figure 6. In single frames two way internal bracing may be installed as shown in 5, figure 6, using braces $\frac{1}{2}$ the thickness of the posts. This type of bracing prevents distortion in either direction.

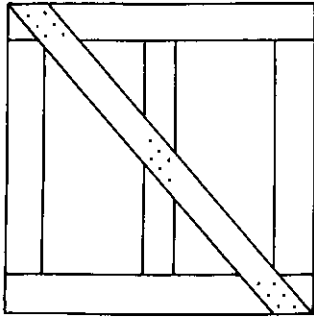

① SPIKED BRACE

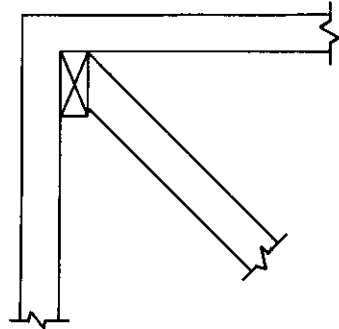

② DIAGONAL BETWEEN STRUTS

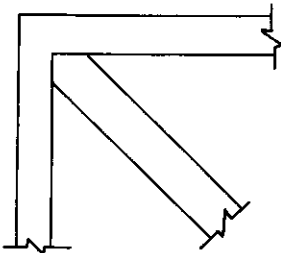

③ DIAGONAL BETWEEN POSTS

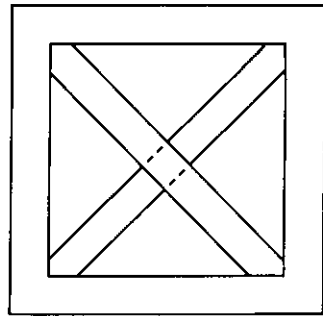

⑤ TWO-WAY DIAGONALS

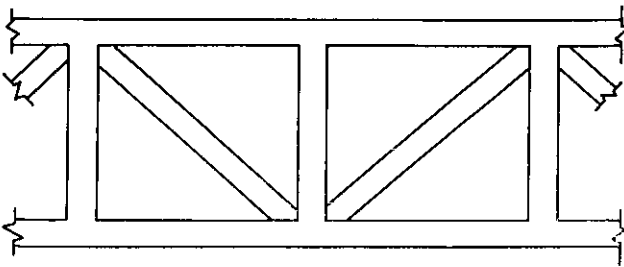

④ ALTERNATE DIAGONALS IN SIDEWALL FRAMES

Figure 6. Standard methods of installing braces.

35. Prefabrication

a. *Applicability.* Items adapted to prefabrication include standard frames, standard sheathing, members for emplacements of post-cap construction and members for modular shelter sections.

b. *Organization and Procedure.* For a prefabrication operation planning begins with a study of the work to be done and the means available. Detail drawings are developed to show the cuts to be made on each member and the finished dimensions. The dimensions include

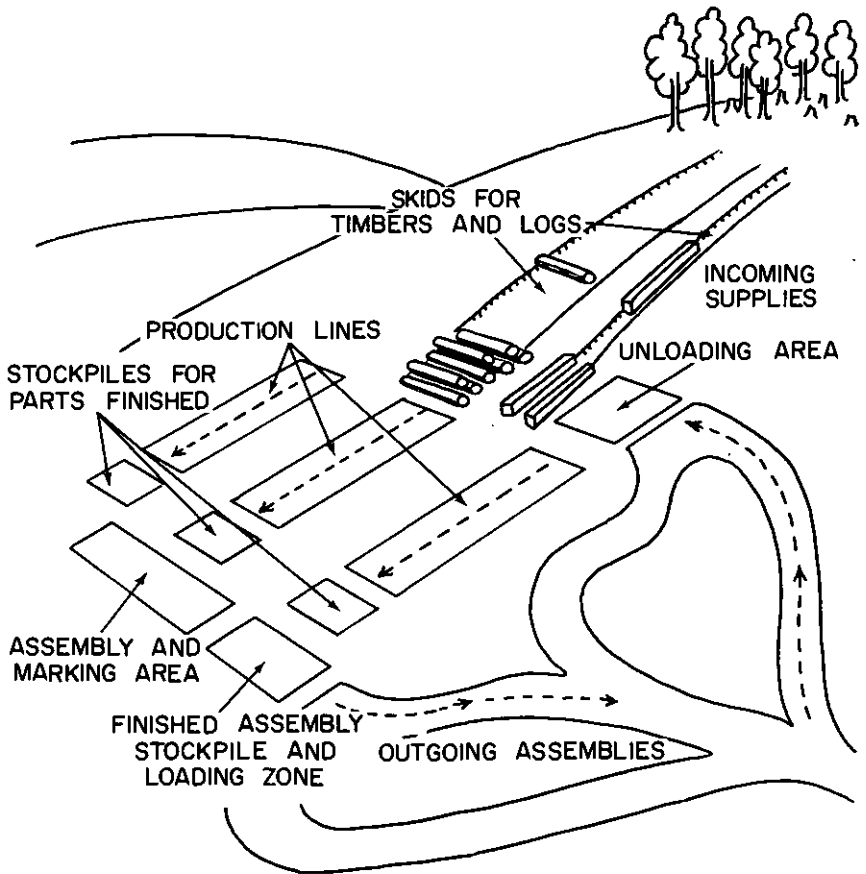

Figure 7. Production line layout for prefabrication.

permissible tolerances for log diameters or lumber dimensions. In developing a production-line layout (fig. 7) for the prefabrication of assemblies, consideration is given to the following requirements:

- (1) The site should be located on a reasonably open area of uniform slope, in which logs will roll downhill on skids and timbers will slide on lubricated skids or in which materials handling equipment such as forklifts can efficiently operate. Truck routes are developed for incoming materials at the upper edge of such a layout and for outgoing assemblies at the lower edge.
- (2) For such products as notched log structures, the members of each assembly should be handled over adjacent parallel lines so that each set can be given a trial assembly at the end of the lines where the members are numbered and marked for later field assembly. For other products, such as standard frames and standard sheathing made of dimension lumber, this feature may be omitted.

- (3) In each line, the first work station should include a layout team to mark the finished lengths and to indicate the faces on which fabricating cuts are to be made. All other stations are provided with full-size templates, patterns, or metal dies for laying out the exact cuts to be made.
- (4) The crews and tools for each work station are estimated and tabulated, and trial runs are made over various lines until an effective operation is developed. For some assemblies, it may be more efficient to combine in one line the fabrication of several of the smaller parts of similar sizes. Such parts may be fabricated at different work stations in the line, or all stations may work alternately on different parts, stockpiling parts at the end of the line to fill the gaps in production.
- (5) An inspection station is established at the end of each line or as a part of the work at trial assembly areas. Such stations stockpile parts for replacement purposes, and return rejected parts to the appropriate raw-material areas for further fabrication. The inspection stations may make such minor corrections as may be practicable, if such corrections result in placing the parts in acceptable condition.
- (6) At the trial assembly areas, for the products for which such assembly is specified, each set of parts is assembled on a level foundation, and when satisfactory the set is disassembled and the parts are numbered to agree with a number layout which will accompany the prefabricated structure.

c. Use of Standard Designs. Standard designs and bills of materials for timber structures suitable for use as emplacements and personnel shelters are given in chapters 8 and 9. Each part is numbered in the drawings in order to facilitate prefabrication. These structures are designed to support overhead cover up to 4 feet thick.

Section II. CONSTRUCTION OF OVERHEAD COVER IN FUNCTIONAL LAYERS

36. General

To provide adequate protection against both penetration and detonation of artillery shells and bombs, a structure would require overhead earth cover so thick as to be impracticable in fighting positions. By combining materials and employing them in layers in a logical sequence, the required protection is provided with less excavation and construction effort. A design of overhead cover in functional layers which protects against the penetration and explosion from a hit by a 155-mm artillery round consists of a camouflage layer, a burster layer, a waterproof layer, a cushion layer, a dustproof layer, and a laminated roof with a total thickness of less than three feet. Figure 8 illustrates a shelter

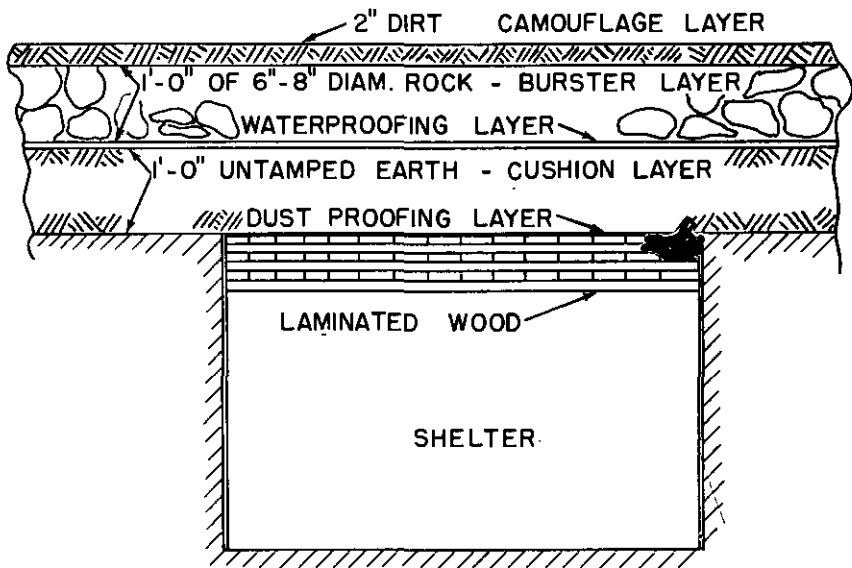

Figure 8. Typical overhead cover constructed in functional layers.

with overhead cover constructed in functional layers. The purpose of each layer and its construction are discussed in paragraphs 37 through 39.

37. Burster and Camouflage Layer

The burster layer covers the entire shelter and extends beyond the shelter on all sides for a distance equal to the depth of the shelter floor beyond the original surface of the ground. The purpose of this layer is to cause detonation of the projectile or deformation of the projectile case before it can penetrate into the lower protective layers. The burster layer is made up of rocks placed by hand. Irregularly shaped rocks of 6- to 8-inch size, placed in two layers with the joints broken, are more effective for the purpose than flat rocks. Logs at least 8 inches in diameter, wired together in a layer, may be used as a substitute material. This log layer is more difficult to install and much more difficult to repair. The burster layer is covered with no more than 2 inches of untamped earth or sod, as a camouflage layer. Greater thickness of camouflage material will tend to increase the explosive effect by introducing a tamping factor.

38. Waterproofing and Dustproofing Layers

These layers may be made up of tar paper with joints well lapped, or canvas or tarpaulins. The dustproof layer just above the roof support prevents dust and dirt from shaking down on weapons and personnel. The waterproof layer is designed to keep moisture from the cushion

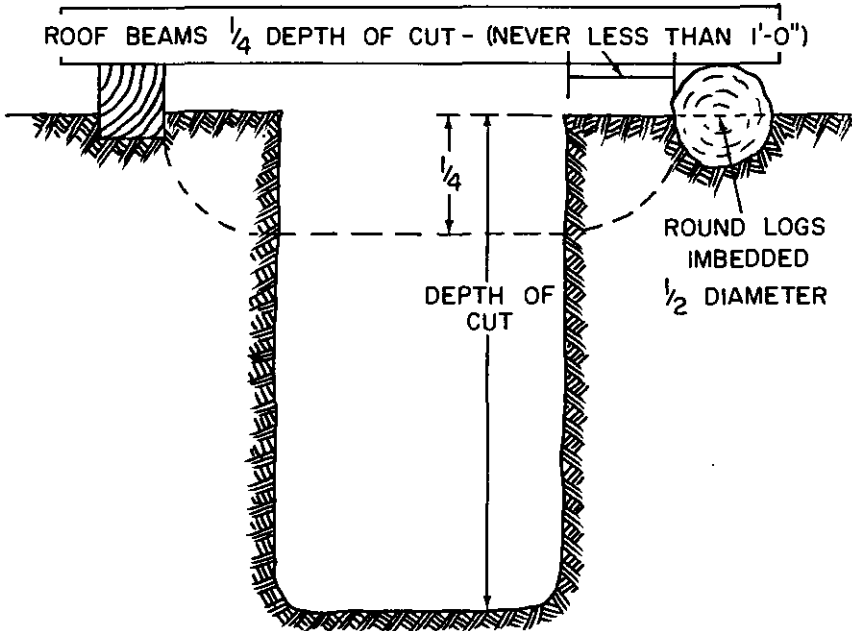

Figure 9. Support of overhead cover on earth banks.

layer in order to retain the cushioning effect of the soft dry earth, and to minimize the dead load the structure must carry.

39. Cushion Layer

The cushion layer is intended to absorb the shock of detonation or penetration. Untamped earth is the best material for the purpose and it should be at least one foot thick. Materials which do not compact, such as loose gravel, transmit excessive shock to the layer below and should not be used in the cushion layer. If the total thickness of cover shown in figure 18 is not thick enough to give the desired attenuation of radiation, the required thickness should be obtained by thickening the cushion layer.

40. Support of Overhead Cover

a. Overhead cover is normally supported on the roof of the structure and the resultant load is transmitted through the caps and posts to the foundation on which the structure rests. It may be necessary in some instances, to support a roof directly on the earth outside a revetted position. Where this must be done, the roof timber should *not* bear on earth immediately outside the excavation because the load may cause an increase in the pressure on the wall to the point where the wall buckles or caves. Instead, the roof structure is carried on timber sills or foundation logs bedded uniformly in the surface at a safe distance

from the cut. This distance should be at least $\frac{1}{4}$ the depth of the cut and in no case less than 1 foot to the nearest edge of the sill. Round logs used for this purpose are embedded to at least half their diameter to provide maximum bearing area of log to soil. The principles are illustrated in figure 9.

- b. (1) Table II below shows the thickness of laminated plank roof required to support various thicknesses of earth cover. The planks should extend from support to support in all layers, and adjoining edges should be staggered from one layer to the next.
- (2) Table III below shows the spacing of stringers required to support a one-inch plank roof under various thickness of earth over various spans. Stringers are 2" \times 4" unless otherwise indicated.
- (3) The data for tables II and III was determined using earth cover loading the roof at 150 lb./ft.³, a maximum bending stress of 2,100 lb./in.², and no allowance for impact loading.

Table II. Thickness in Inches of Laminated Wood Required To Support Various Thicknesses of Earth Cover Over Various Spans

| Thickness of earth cover in feet | Span width in feet | | | | | |
|----------------------------------|--------------------|---|----|---|---|---|
| | 2½ | 3 | 3½ | 4 | 5 | 6 |
| 1½ | 1 | 1 | 2 | 2 | 2 | 2 |
| 2 | 1 | 2 | 2 | 2 | 2 | 3 |
| 2½ | 1 | 2 | 2 | 2 | 2 | 3 |
| 3 | 2 | 2 | 2 | 2 | 3 | 3 |
| 3½ | 2 | 2 | 2 | 2 | 3 | 3 |
| 4 | 2 | 2 | 2 | 2 | 3 | 4 |

Table III. Center to Center Spacing, in Inches, of Wooden Stringers Required To Support a One-Inch Thick Wood Roof With Various Thicknesses of Earth Cover Over Various Spans

| Thickness of earth cover in feet | Span width in feet | | | | | |
|----------------------------------|--------------------|----|-------|-------|-------|-----|
| | 2½ | 3 | 3½ | 4 | 5 | 6 |
| 1½ | 40 | 30 | 22 | 16 | 10 | 18* |
| 2 | 33 | 22 | 16 | 12 | 8/20* | 14* |
| 2½ | 27 | 18 | 12 | 10 | 16* | 10* |
| 3 | 22 | 14 | 10 | 8/20* | 14* | 8* |
| 3½ | 18 | 12 | 8/24* | 18* | 12* | 8* |
| 4 | 16 | 10 | 8/20* | 16* | 10* | 7* |

Note. Stringers are 2" \times 4" except those marked by an asterisk (*) which are 2" \times 6".

- (4) The roof designs shown here are not designed to be shellproof, even under a laminated earth and rock cover. The roofs shown with the cover indicated are fragment proof and will give substantial radiation protection, if properly designed entrances are provided. These roofs may under certain conditions be shellproof.
- c. Sandbags should never be used to support overhead cover.

Section III. REVETMENTS FOR EARTH BANKS

41. General

a. *Definition.* A revetment is a support for a vertical or nearly vertical earth bank which prevents the earth from caving or falling into the excavation.

b. *Uses.* Earth banks in emplacements and shelters are revetted to protect against—

- (1) Blast and earth shock from explosion.
- (2) Weathering of positions during extended periods of occupation.
- (3) Naturally unstable soil conditions.

42. Types

Revetments used in the construction of emplacements and shelters may be either of the retaining wall type or of the facing type. Each of the types is discussed in detail in *a* and *b* below.

a. *Retaining Wall Type.* This type of revetment is used in relatively unstable soils. It resists the tendency of the sides of an emplacement or shelter to slide into the excavated area. This tendency is overcome by the weight of the wall itself imbedding the lower course of the wall in the firm earth below the floor of the emplacement or shelter and the fact that it is sloped toward the side of the excavation as shown in figure 10. The horizontal layers of the wall are tied together so that the wall acts as a structural unit, without any sliding of one part upon another. This type of revetment (fig. 10) may be constructed of sandbags, sod blocks and various expedients as described in paragraph 43.

b. *Facing Type.*

- (1) *General.* Facing revetment serves mainly to protect revetted surfaces from the effects of weather and damage caused by occupation. It is used only when soils are stable enough to sustain their own weight. This type of revetment (fig. 11) consists of the revetting or facing material and the supports which hold the revetting material in place. The facing material may be much thinner than that used in a retaining wall. For this reason facing type revetments are preferable since less excavation is required. The top of the facing should

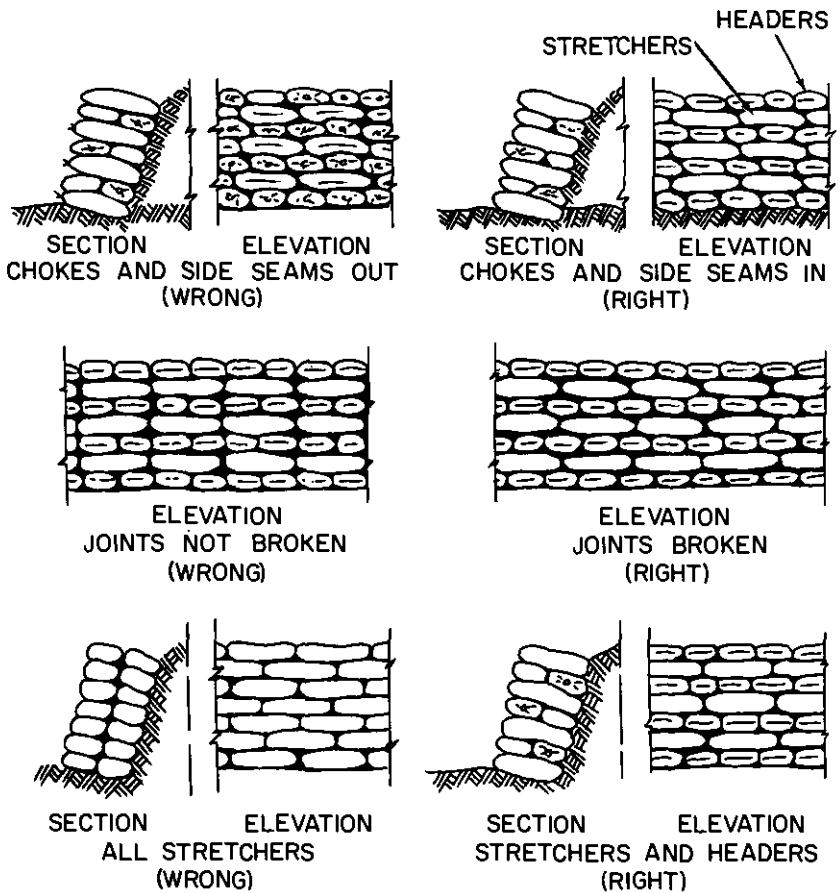
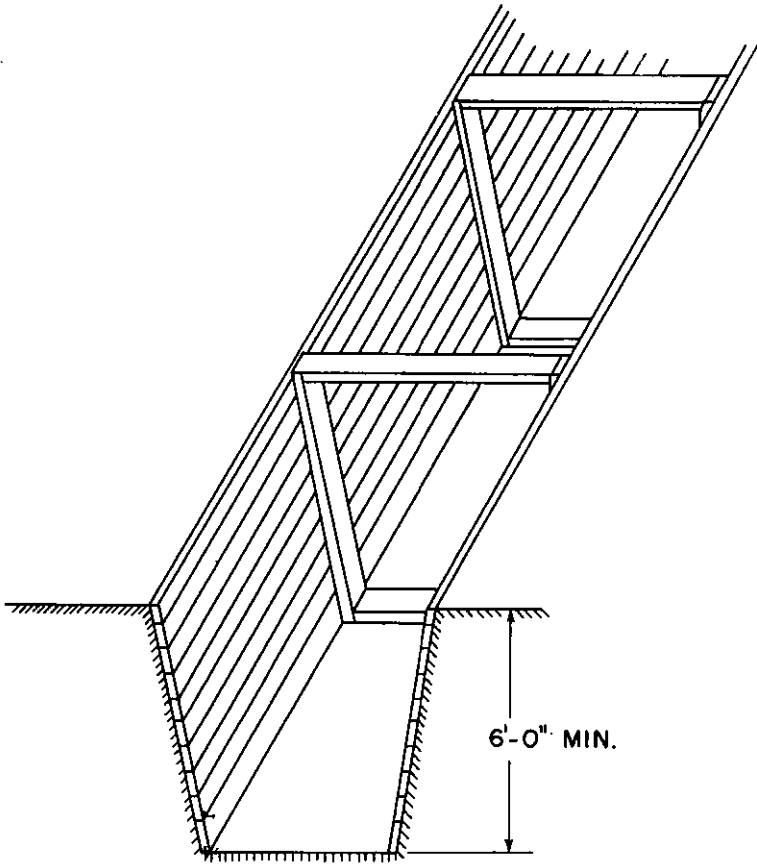

Figure 10. Retaining wall type of revetment.

be set below ground level so that the revetting is not damaged by tanks crossing the emplacement.

- (2) *Materials for facing.* The facing may be constructed of brushwood hurdles, continuous brush, pole and dimensioned timbers, corrugated metal, or burlap and chicken wire. The method of constructing each type is described in paragraph 44.
- (3) *Methods of support.* The facing may be supported by—
 - (a) *Timber frames.* Frames of dimensioned timber (1, fig. 11) are constructed to fit the bottom and sides of the position, and hold the facing material apart over the excavated width.
 - (b) *Pickets.* The pickets are driven into the ground on the position side of the facing material and held tightly against the facing as shown in 2, figure 11 by bracing the pickets apart across the width of the position and anchoring the tops of the pickets by means of stakes driven into the ground and tiebacks.



① SUPPORTED BY FRAMES

Figure 11. Facing type of revetment.

43. Methods of Constructing Retaining Wall Type Revetments

a. Sandbags.

- (1) *Uses and limitations.* Sandbags are useful for temporary revetments, especially where silent installation is essential. Sandbags used in revetments rot in damp weather and pale in the sunlight. They cannot be counted on for a useful life of more than one to six months unless they are stabilized as described in (3) below.
- (2) *Dimensions and weights.* The standard sandbag measures 14 by 26 inches when empty, and a bundle of 200 empty sandbags weighs about 80 pounds. Properly filled to $\frac{3}{4}$ of full capacity, the bag weighs from 40 to 75 pounds, depending upon the type and moisture content of the filler and occupies

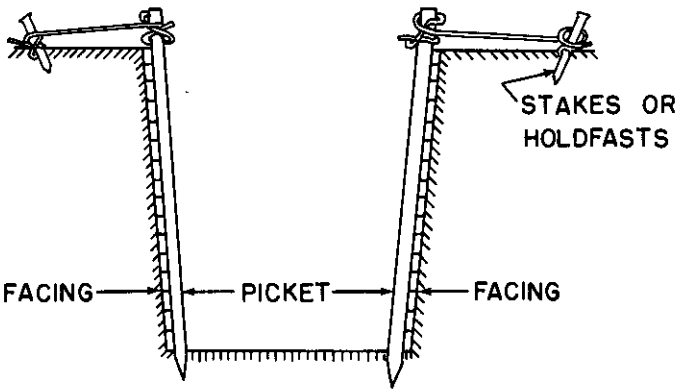
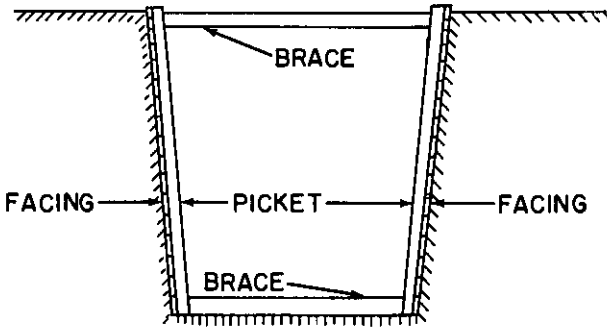

② SUPPORTED BY PICKETS

Figure 11—Continued.

a space about 5 by 10 by 20 inches. When laid in the standard revetment, a double row of alternate headers and stretchers as shown in figure 10, about 320 sandbags are required per 100 square feet of revetted surface.

- (3) *Stablization*. Sandbags may be stablized by filling them with a mixture of dry earth and portland cement, normally in the ratio of 1 part of cement to 10 parts of dry earth. The bags remain plastic until installed, and setting of the cement occurs later as the bags take on moisture. If the filler is a very sandy soil or a sand-gravel mixture the cement to sand ratio should be increased to about 1 to 6. An alternative method is to dip the filled bags in a cement and water slurry before setting them in place.

STAKES OR HOLDFASTS
PLACED HERE AS IN
FIGURE 11

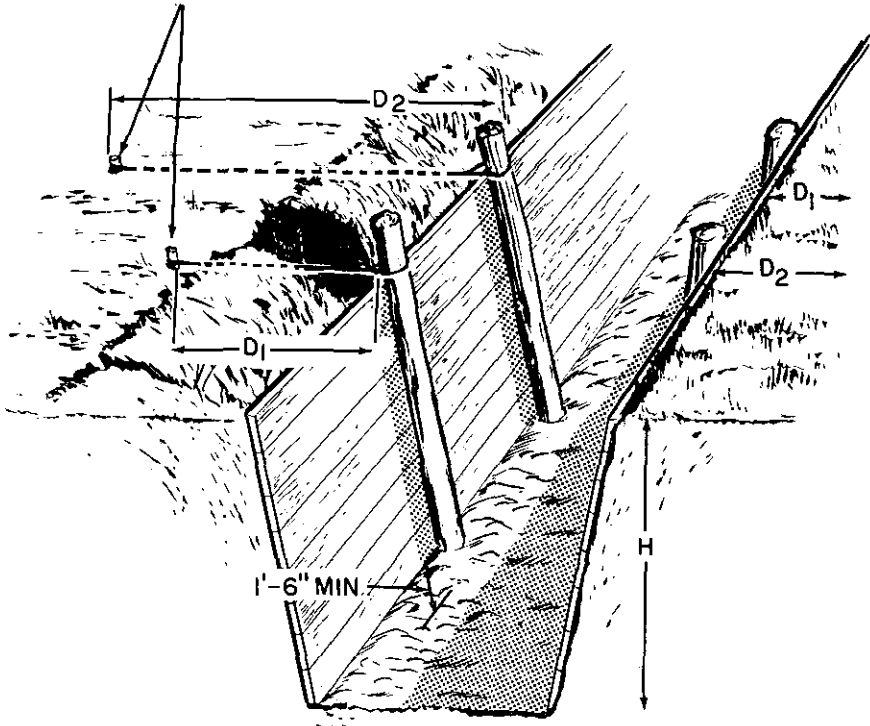

D_1 IS EQUAL TO OR GREATER THAN H
 D_2 IS EQUAL TO $H+2'$

Figure 12. Method of anchoring pickets.

(4) Construction procedure.

- (a) The bags are uniformly filled about $\frac{3}{4}$ full with earth or with a dry soil-cement mixture and the choke cords are tied.
- (b) The bottom corners of the bags are tucked in after filling.
- (c) The foundation of the revetment is pitched to slope the wall toward the revetted face at a slope of 3 or 4 to 1. As the revetment is built, the revetted face is made to conform to this slope by backfilling or additional excavation. When stabilized sandbags are used the foundation should be about 6 inches below the floor level of the revetted position, so that the earth of the floor helps the wall resist sliding.
- (d) Sandbags are laid so that the planes between the layers have the same pitch as the foundation, i.e., at right angles to the slope of the revetment.

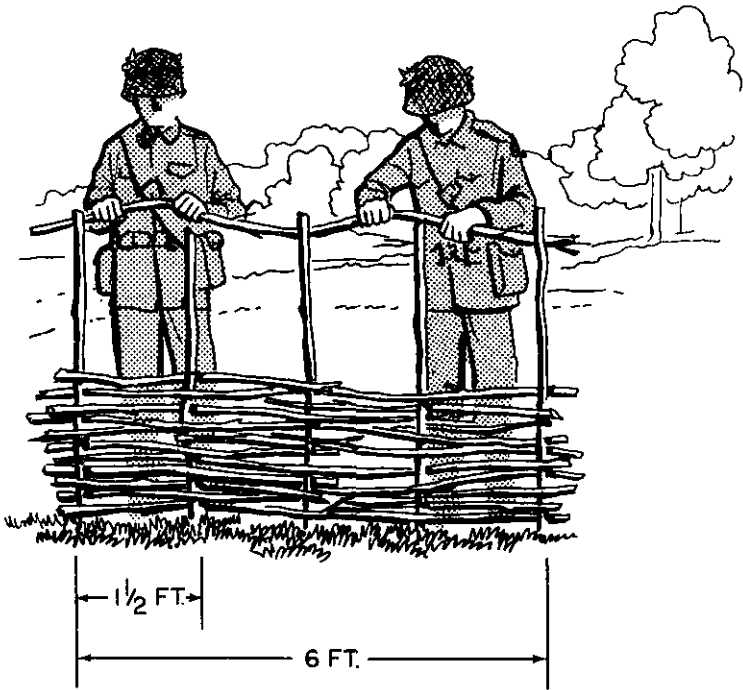

Figure 13. Making a brushwood hurdle.

- (e) The bottom row of the revetment is constructed with all bags placed as headers (fig. 10). The wall is then constructed using alternate rows of stretchers and headers with the joints broken between courses (fig. 10). The top row of the revetment wall consists of headers.
- (f) All bags are placed so that side seams on stretchers and choked ends on headers are turned toward the revetted face.

b. Sod Blocks. Thick sod with good root systems provides a satisfactory revetting material. Sod blocks cut into sections about 9 by 18 inches are laid flat, using the alternate stretcher-header method described above for use with sandbags. Sod is laid grass-to-grass and soil-to-soil, except for the top layer which should be laid with the grass upward, to provide natural camouflage. As each layer of sod is completed, wooden pegs are driven through the layers to prevent sliding until the roots grow from layer to layer. Two pegs are driven through each 9- by 18-inch sod. Sod revetment are laid at a slope of about 3 vertical to 1 horizontal.

c. Expedients. In cold weather blocks of ice may be used to construct retaining wall type revetments. They are stacked in the same manner as sandbags or sod; water is applied to bind them together by freezing. Other expedients include earth-filled packing cases or am-

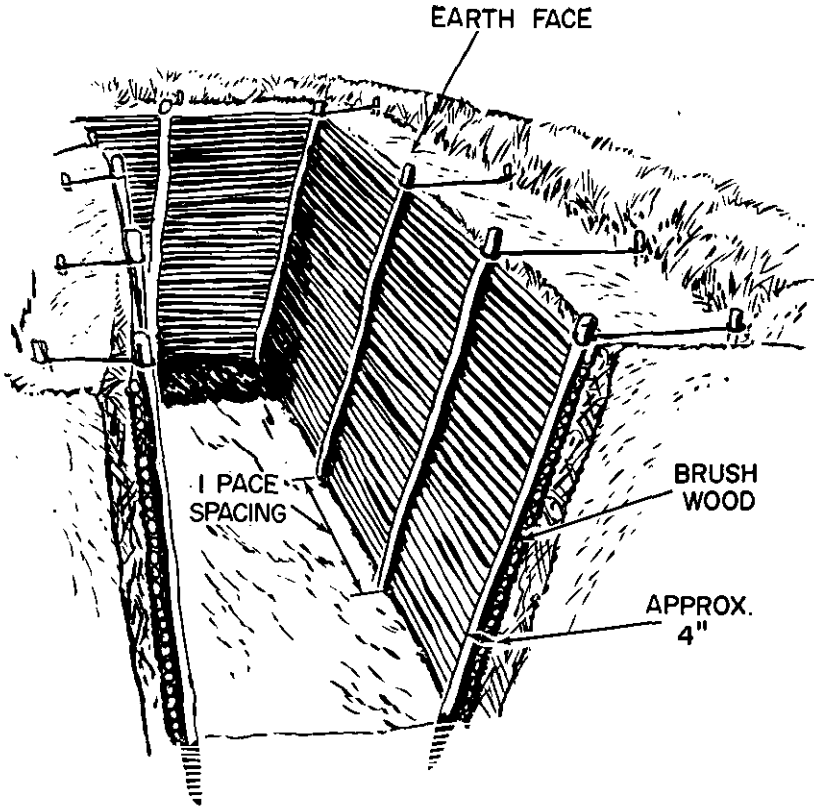
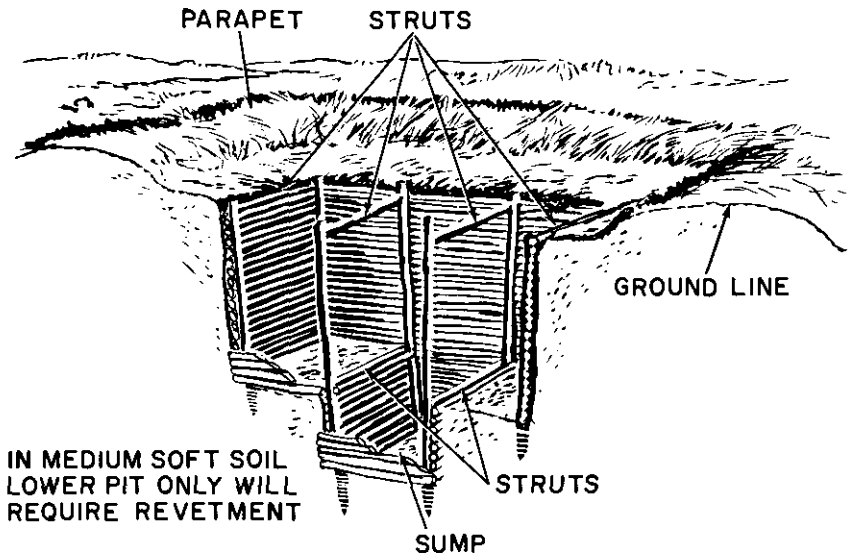

Figure 14. Continuous brush revetment.

munition boxes. Empty boxes or packing cases are placed in position and nailed or spiked to the lids of the layer below; the boxes are then filled with earth or rock and the lids fastened in place. This procedure is repeated for each row. To prevent overturning or sliding, the tops of these revetments are tied back to pickets as described in paragraph 44 for facing type revetments.

44. Methods of Constructing Facing Type Revetments

a. General. As described in paragraph 42b(3), facing type revetments may be supported either by timber frames or pickets. The size of pickets required, and their spacing, is determined by the size of the soil and the type of facing material used. To facilitate driving wooden pickets should not be smaller than 3 inches in diameter or in smallest dimension. The maximum spacing between pickets should be about 6 feet. The standard U-shaped pickets normally used to support barbed wire entanglements are excellent for use in revetting. Pickets are driven at least 1½ feet into the floor of the position. Where the tops of the pickets are to be anchored, an anchor stake or holdfast is



① SMALL POLES

Figure 15. Types of timber revetments.

driven into the top of the bank opposite each picket and the top of the picket is racked to it as shown in figure 12. The distance between the anchor stake and the facing is at least equal to the height of the revetted face, with alternate anchors staggered and at least 2 feet farther back. The wire holding the pickets against the emplacement walls must be straight and taut. A groove or channel may have to be cut in the parapet to pass the wire through. After the picket has been made tight, the groove should be filled in.

b. Brushwood Hurdle. A brushwood hurdle is a woven revetment unit usually 6 feet long and of the required height. As shown in figure 13 pieces of brushwood about 1 inch in diameter are woven on a framework of sharpened pickets driven into the ground at 18-inch intervals. When completed, the 6-foot lengths are pulled up and carried to the position, where the pickets are driven in place and the tops of the pickets are tied back to stakes or holdfasts. The ends of the hurdles are then wired together.

c. Continuous Brush. As shown in figure 14 a continuous brush revetment is constructed in place. Sharpened pickets 3 inches in diameter are driven in the bottom of the trench at 1-pace intervals and about 4 inches from the earth face to be revetted. The space behind the pickets is packed with small straight brushwood laid horizontally and the tops of the pickets are anchored to stakes or holdfasts.

d. Pole and Dimensioned Timber. A pole revetment (fig. 15) is similar to the continuous brush revetment except that a layer of small

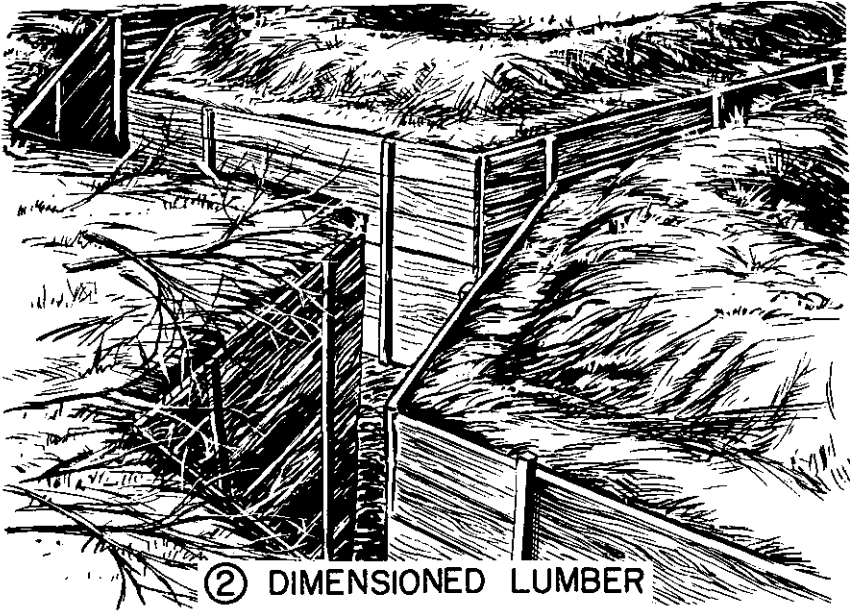

Figure 15—Continued.

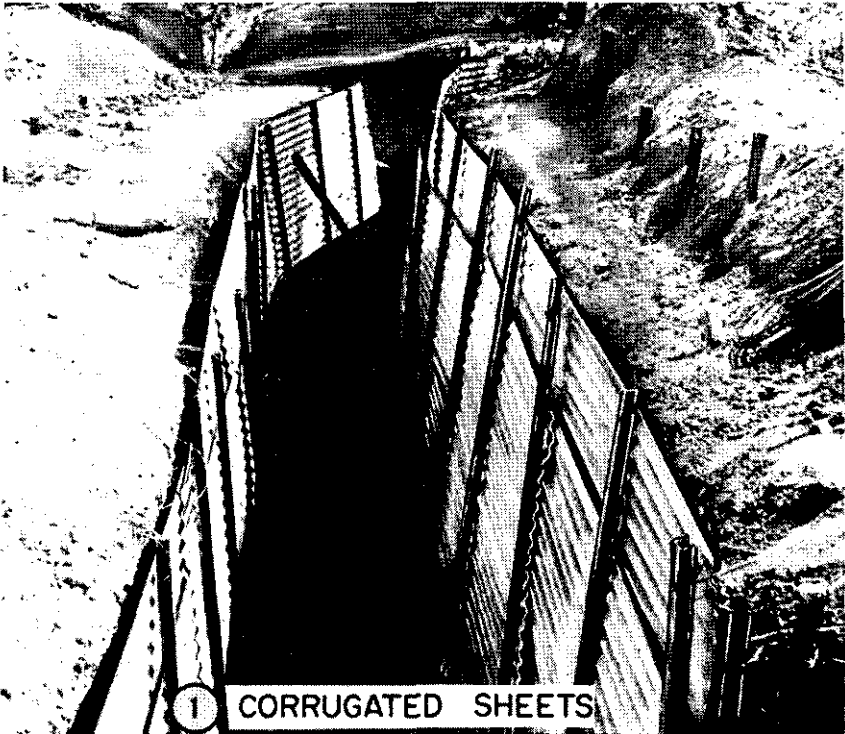
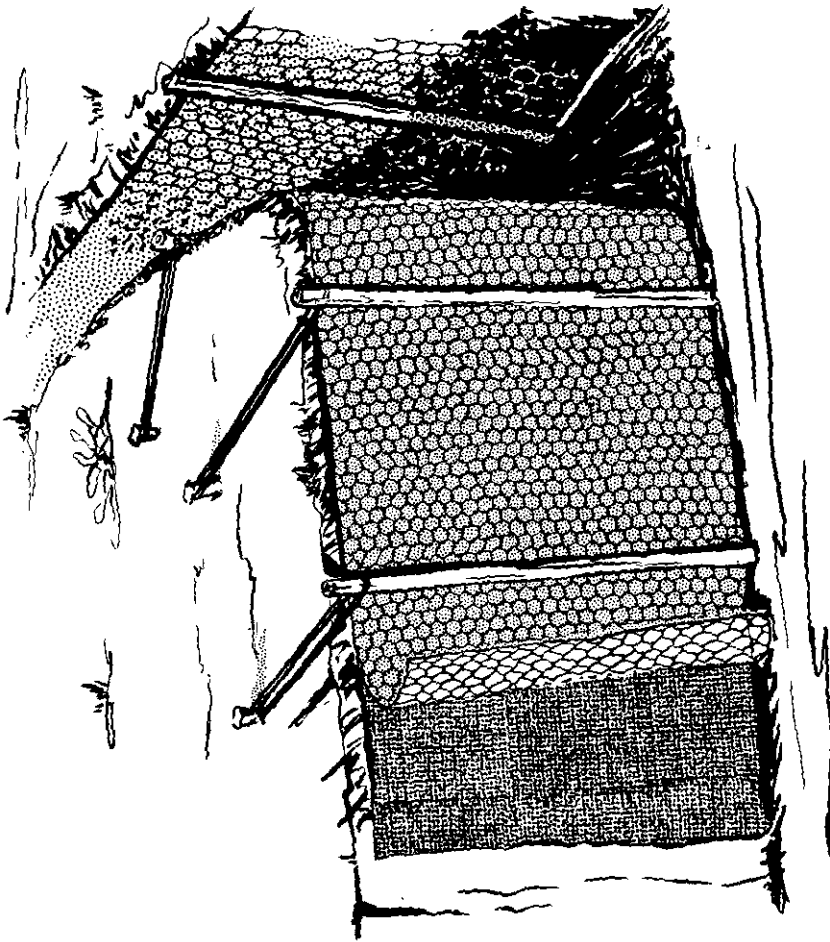

Figure 16. Metal revetment.



② BURLAP AND CHICKEN WIRE

Figure 16—Continued.

horizontal round poles, cut to the length of the wall to be revetted, is used instead of brushwood. Boards or plank, if available, are used instead of poles and can be installed more quickly. Pickets are held in place by holdfasts or struts.

e. Metal. A revetment of corrugated metal sheets (1, fig. 16) or pierced steel plank may be installed rapidly and is strong and durable. It is well adapted to emplacement construction because the edges and ends of sheets or planks can be lapped as required to produce a revetment of a given height and length. All metal surfaces must be smeared with mud to eliminate possible reflection of thermal radiation and to aid camouflage. Burlap and chicken wire revetments are installed as shown in 2, figure 16. When damaged, corrugated metal forms dangerous sharp edges. Prompt attention should be given to the repair of damaged revetments to prevent injuries to personnel or damage to equipment.

Section IV. DRAINAGE

45. Principles

a. Emplacements and shelters are sited to take advantage of the natural drainage pattern of the ground and construction so as to provide for—

- (1) Exclusion of surface runoff.
- (2) Disposal of direct rainfall or seepage.
- (3) Bypassing or rerouting natural drainage channels if they are intersected by the emplacement or shelter.

b. The methods of providing for each of the above are described in paragraphs 46 and 47.

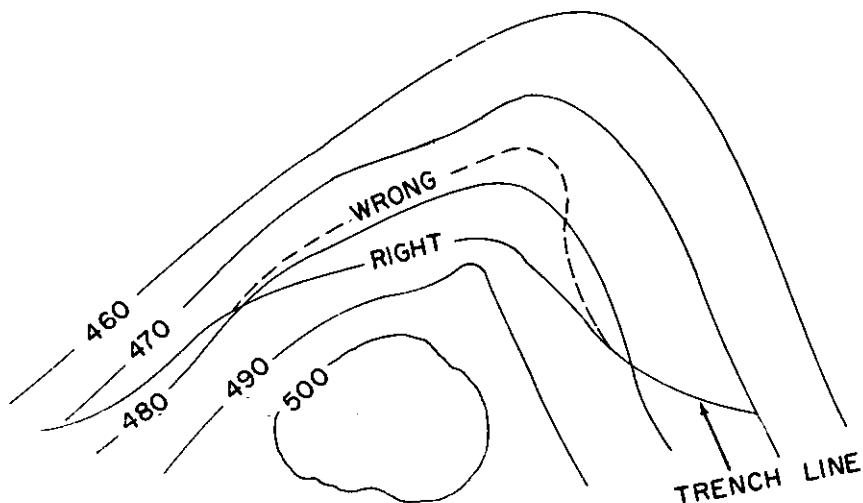

Figure 17. Siting to lessen problem of disposal of runoff water.

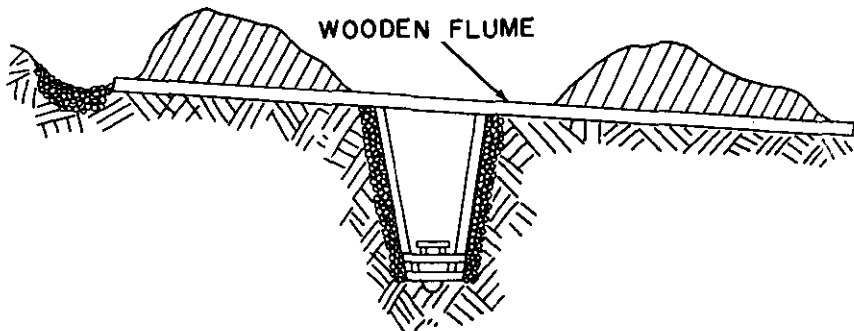

Figure 18. Use of open flume to direct water across trench.

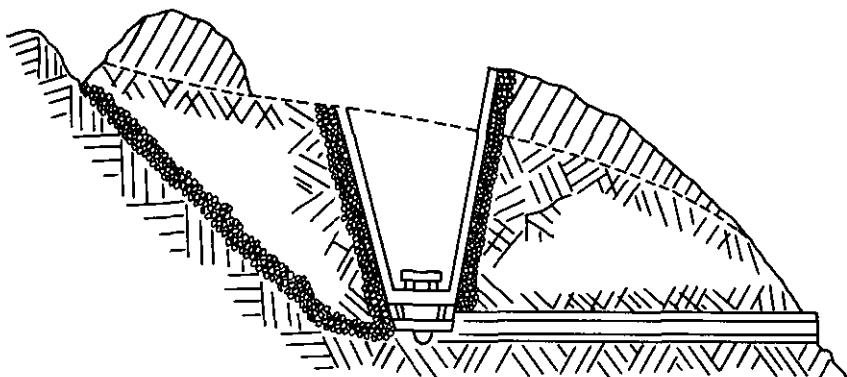

Figure 19. Use of under trench drains.

46. Exclusion of Surface Runoff

Proper siting, as illustrated in figure 17 can lessen this problem by locating the emplacement of shelter in an area not subject to excessive runoff. Surface water may be excluded by excavating interceptor ditches up slope from the emplacement or shelter. It is much easier to prevent surface water from flowing in than to remove it after it has gained access. Emplacements and shelters should be sited so as to direct the water to natural drainage lines. If this is not possible with trenches, the water is conducted across the trench through open flumes developed for the purpose or under the trench using a combination of trench drains and culverts. An application of the open flume method for use with trenches is shown in figure 18, a typical under trench drain in figure 19.

47. Disposal of Direct Rainfall or Seepage

Water collecting within an emplacement or shelter is carried to central points by providing longitudinal slopes in the bottom of the excavation. A very gradual slope (1 percent or 1 foot in 100 feet) is

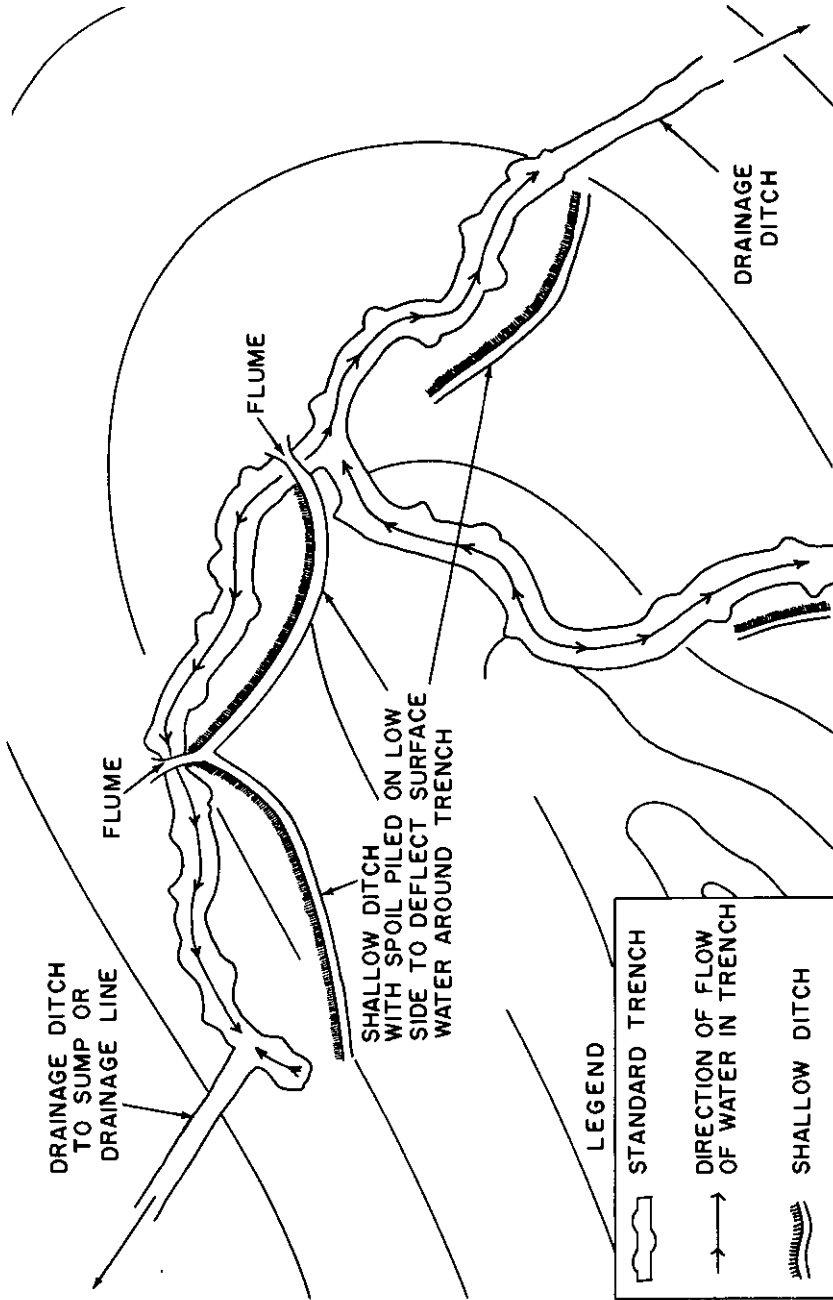

Figure 20. Method of siting trench to provide longitudinal drainage.

desirable. In trenches the slope is best provided for by fitting the trench to the terrain in such a way that the original surface has a moderate slope, as shown on the contoured layout in figure 20. When permitted by the tactical situation excavation of trenches should commence at the lowest level and progress upward in order to avoid collecting water in the bottom of a partially completed trench. The central collecting points may be either natural drainage lines or sumps below the bottom of the excavation as shown in figure 21. Such sumps are located at points from which water will percolate through permeable soil or can be piped, pumped, or bailed out. If pumps are not available, a lift type pump can be improvised from a square wooden box with a plunger fitted with a leather flap as shown in figure 22.

48. Maintenance

All drains and sumps should be kept clear including the interceptor ditches for surface drainage. Earth thrown into excavations from shell explosions or from cave-in should be removed so that water will not back up and cause caving at other points.

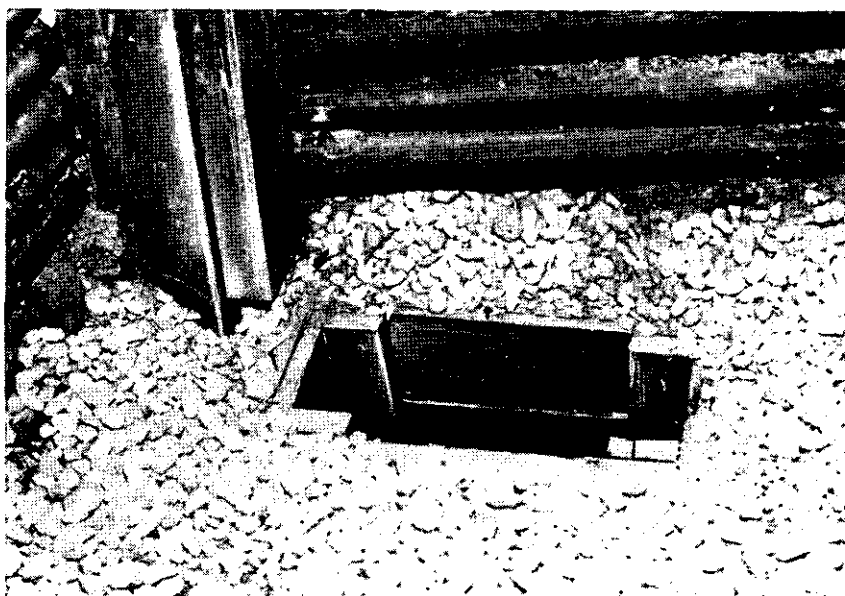

Figure 21. Drainage sump in bottom of excavation.

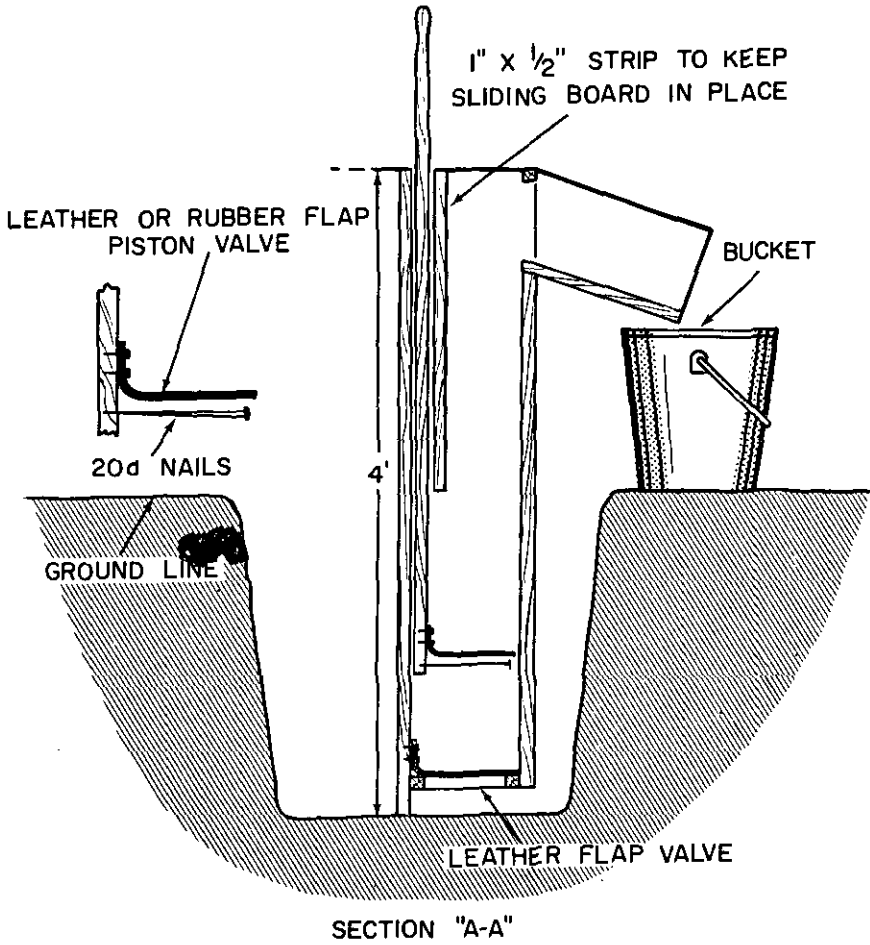
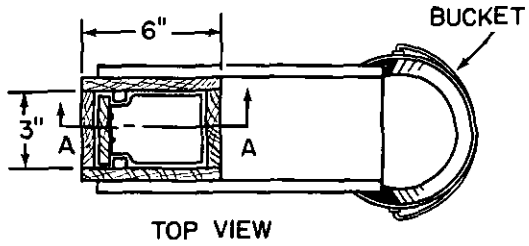

Figure 22. Improvised lift-type pump.

CHAPTER 8

PERSONNEL AND INDIVIDUAL WEAPONS

Section I. EMBLEMMENTS

49. General

An emplacement is a prepared position, for one or more weapons or pieces of equipment for protection against hostile fire or bombardment, and from which they can execute their tasks.

50. Emergency Emplacements

Before construction of individual foxholes is begun, and if the situation permits, the squad leader has each man lie down at the position selected for him and personally verify the sectors of observation and fire. If the situation is stabilized, at least temporarily, the positions are so selected as to be capable of being connected later. There are emergency situations, however, in which elements may be stopped where no natural cover is available and men may have to dig in without such preparation. Three types of emergency emplacements which provide protec-

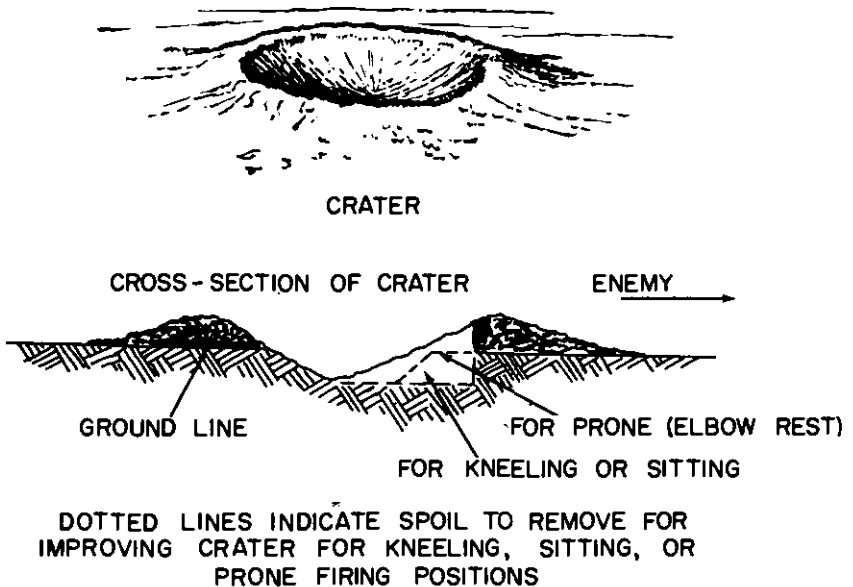

Figure 23. Improved crater.

tion against flat-trajectory fire are discussed here. A tabulation of the protection afforded by each is included in table VI.

a. *Improved Crater.* A shell or bomb crater of adequate size offers immediate cover and concealment and is readily improved as shown in figure 23. By digging the crater to a steep face on the side toward the enemy, the occupant provides himself with a firing point for use in the kneeling, sitting, or prone firing positions. A small crater can later be developed into a foxhole. A large crater used in this manner does not afford protection if overrun by a tank.

b. *Skirmisher's Trench.* This shallow pit-type emplacement (fig. 24) provides a temporary, open prone firing position for the individual rifleman. When the situation demands immediate shelter from heavy enemy fire and when existing defiladed firing positions are not available, each soldier lies prone or on his side, and with his intrenching tool, scrapes and piles the soil in a low parapet between him and the enemy. Thus a shallow, bodylength pit can be formed quickly in all but the hardest ground. The trench should be oriented with respect to the enemy line of fire so that it is least vulnerable to enfilade fire. In a skirmisher's trench, a soldier presents a low silhouette to the enemy and is afforded some protection from small arms fire. Should the gen-

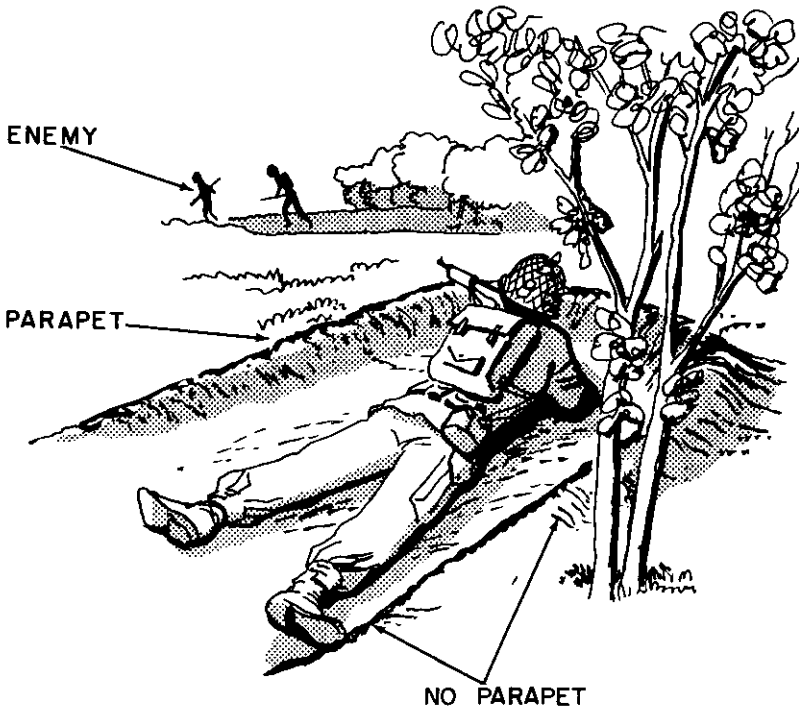

Figure 24. Skirmisher's trench.

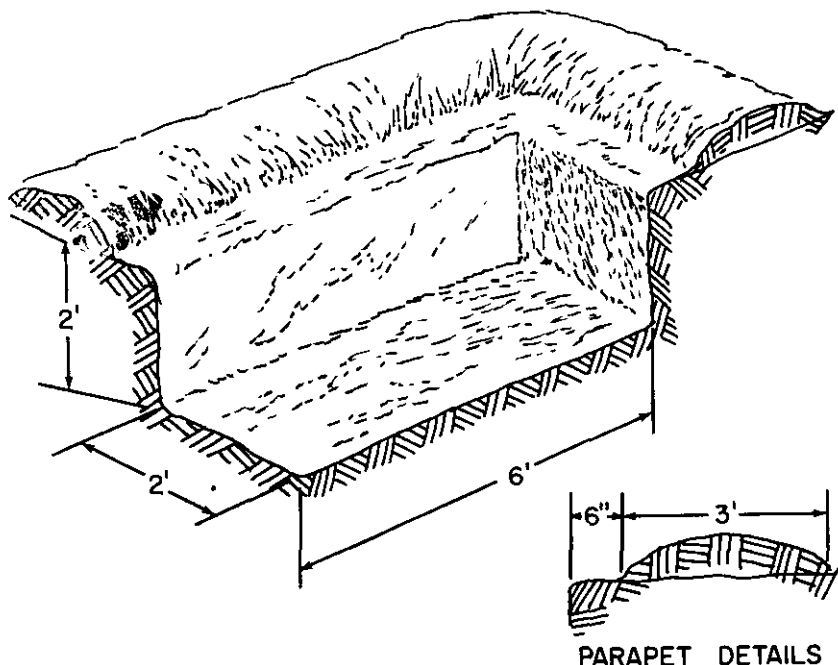

Figure 25. Prone emplacement.

eral attack halt along this line of advance, the trench can be developed into a foxhole or a prone shelter.

c. Prone Emplacement. This emplacement (fig. 25) is a further refinement of the skirmisher's trench. It provides a firing position for the individual rifleman, and, in addition, affords greater protection against small arms and direct fire artillery. By virtue of its additional depth it provides limited protection against the effects of nuclear weapons.

51. Foxholes

The foxhole is the basic defensive position of the individual rifleman. The standard types are the one- and the two-man foxhole. The size, shape, and methods of construction of a foxhole as a fighting position vary with the tactical situation and condition of the terrain. Foxholes may be developed from well-sited craters, skirmisher's trenches, or prone emplacements. All fighting positions are sited primarily for good field of fire; concealment is a secondary consideration. Types of foxholes are described and illustrated in *a* and *b* below. A tabulation of the protection afforded by each type is included in table VI.

a. One-Man Foxhole. This type of foxhole may be constructed either open or with a half cover (figs. 26 and 27). In either case it may be constructed with or without an offset.

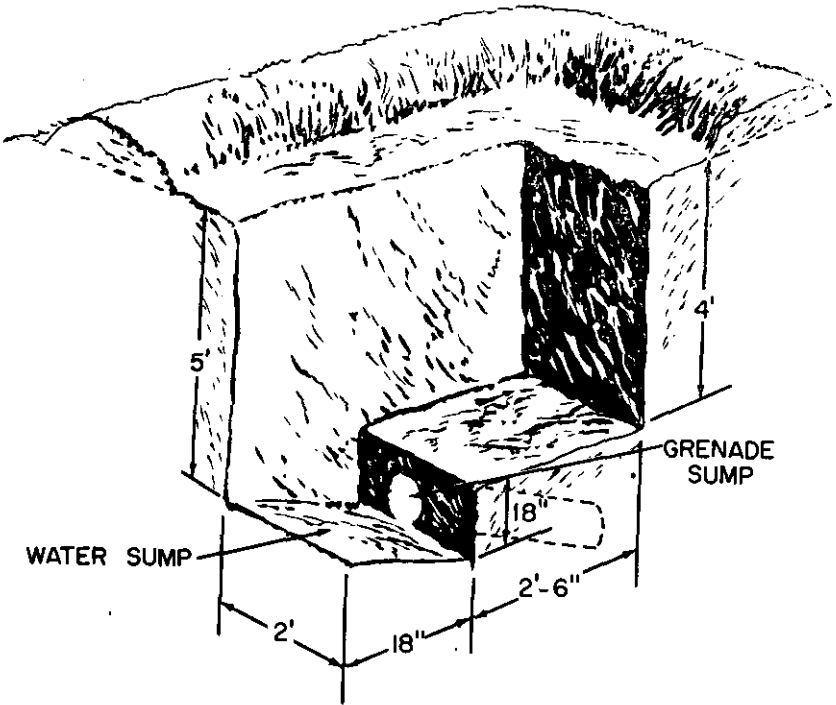

① WITHOUT OFFSET

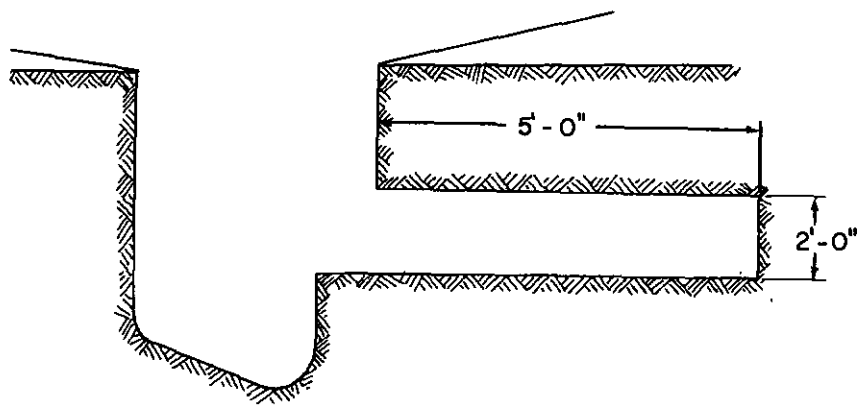

② WITH OFFSET

Figure 26. Open one-man foxhole.

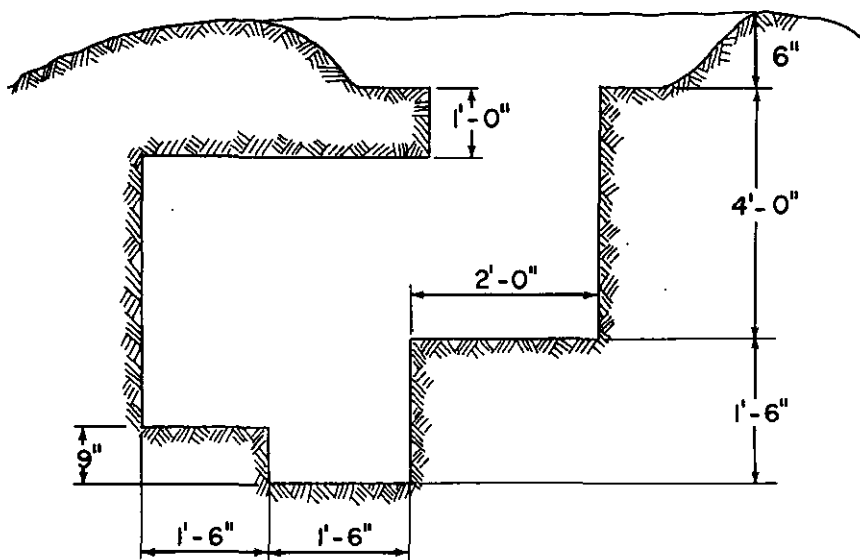

① WITHOUT OFFSET

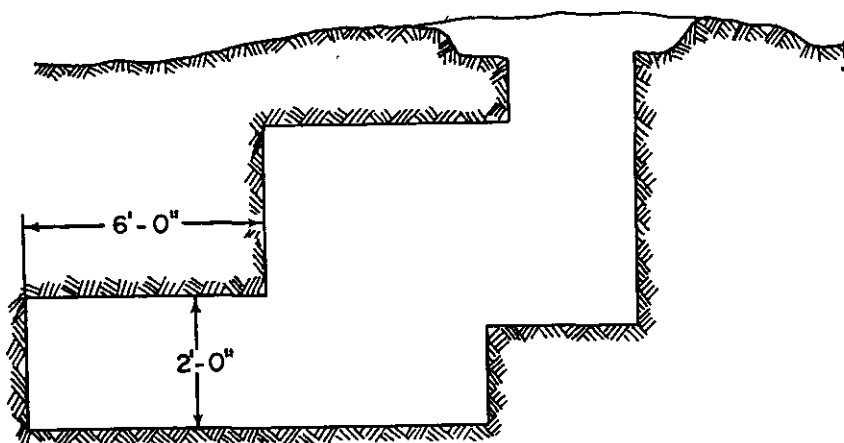

② WITH OFFSET

Figure 27. One-man foxhole with half cover.

(1) *Dimensions and layout.* The overall dimensions and layout of the one-man foxhole are as shown in figures 26 and 27.

(2) *Construction details.*

- (a) *Fire step.* The depth to the fire step will depend upon the height of a comfortable firing position for the occupant, normally $3\frac{1}{2}$ to 5 feet. The occupant, crouched in a sitting position on the fire step, must have at least 2 feet of overhead clearance if a tank overruns the foxhole. This will normally provide protection against the crushing action of tanks; however, in some soils it will be necessary torevet the walls of the foxhole in order to provide this protection.
- (b) *Water sump.* A water sump, 18 inches by 2 feet and 18 inches deep below the fire step, is dug at one end of the foxhole to collect water and to accommodate the feet of a seated occupant.
- (c) *Grenade sump.* A circular grenade sump 8 inches in diameter, 18 inches long, and sloped downward at an angle of 30° , is excavated under the fire step, beginning at the lower part of the fire step riser. Hand grenades thrown into the foxhole are disposed of in this sump, and their fragmentation is restricted to the unoccupied end of the foxhole. For good drainage and to assist in disposing of grenades, the fire step is sloped toward the water sump, and the bottom of the water sump is funneled downward to the grenade sump.
- (d) *Parapet.* If excavated spoil is used as a parapet, it should be placed as a layer about 3 feet wide and 6 inches high all around the foxhole, but leaving an elbow rest of original earth about 1 foot wide next to the foxhole. If sod or topsoil is used to camouflage the parapet, the sod or topsoil should be removed from the foxhole and parapet area, set aside until the parapet is complete, and then placed on the parapet in a natural manner.
- (e) *Camouflage.* Whether or not a parapet is constructed in wooded or brushy type terrain, a foxhole can be camouflaged effectively with natural materials, as shown in figure 28. In open or cultivated areas, it may be preferable to omit the parapet, remove the excavated spoil to an inconspicuous place, and improvise a camouflage cover for the foxhole. This is a light, open frame of branches garnished with grass or other natural foliage to match the surroundings. As an alternate method, the foxhole can be covered with a shelter-half or other expedient material, and further covered with snow or some other material, according to local terrain conditions (fig. 28). The occupant raises one side of the cover for observation or firing.

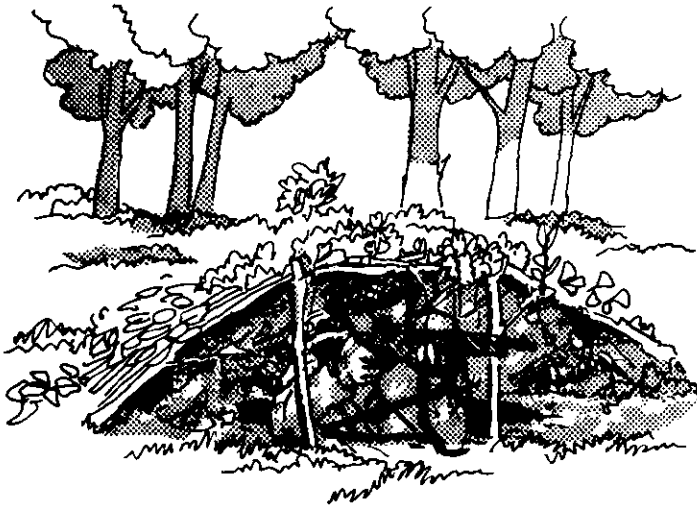

① FOXHOLE WITH CAMOUFLAGE COVER IN PLACE

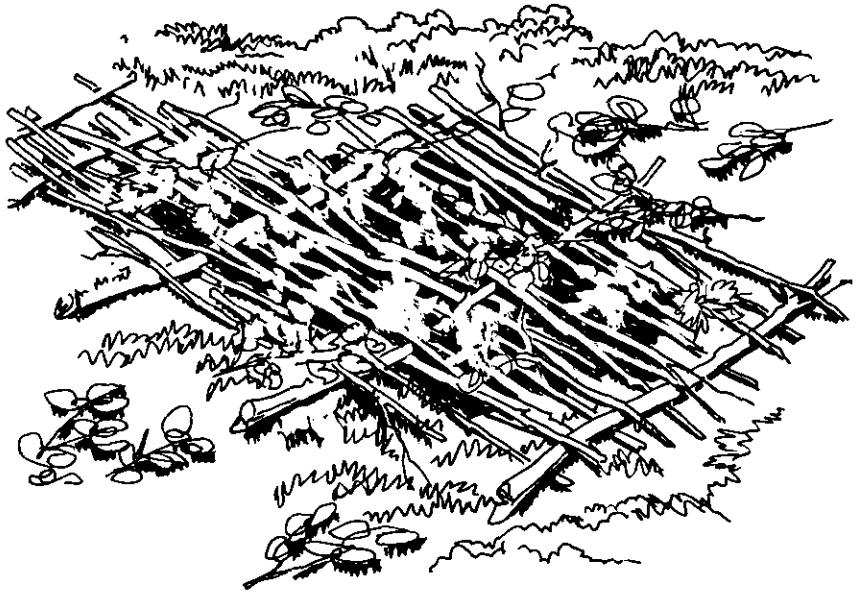

② METHOD OF CONSTRUCTING COVER

Figure 28. Camouflaged one-man foxhole.

(f) *Overhead cover.* The half overhead cover for the one-man foxhole, as illustrated in figure 27 is constructed as described in paragraph 40.

(g) *Offsets.* The offsets shown in figures 26 and 27 are usually constructed as refinements of the basic foxhole; they are excavated using handtools, to the dimensions required by the individual. The spoil may be added to the parapet or to the overhead cover.

b. *Two-Man Foxhole.* This type of foxhole may be constructed either open, with half overhead cover, or with full overhead cover (figs. 29-31). Those constructed with either a full or a half overhead cover may be revetted and provided with an offset or adjoining shelter. The open foxhole may be deepened to provide additional protection.

TWO MAN FOXHOLE

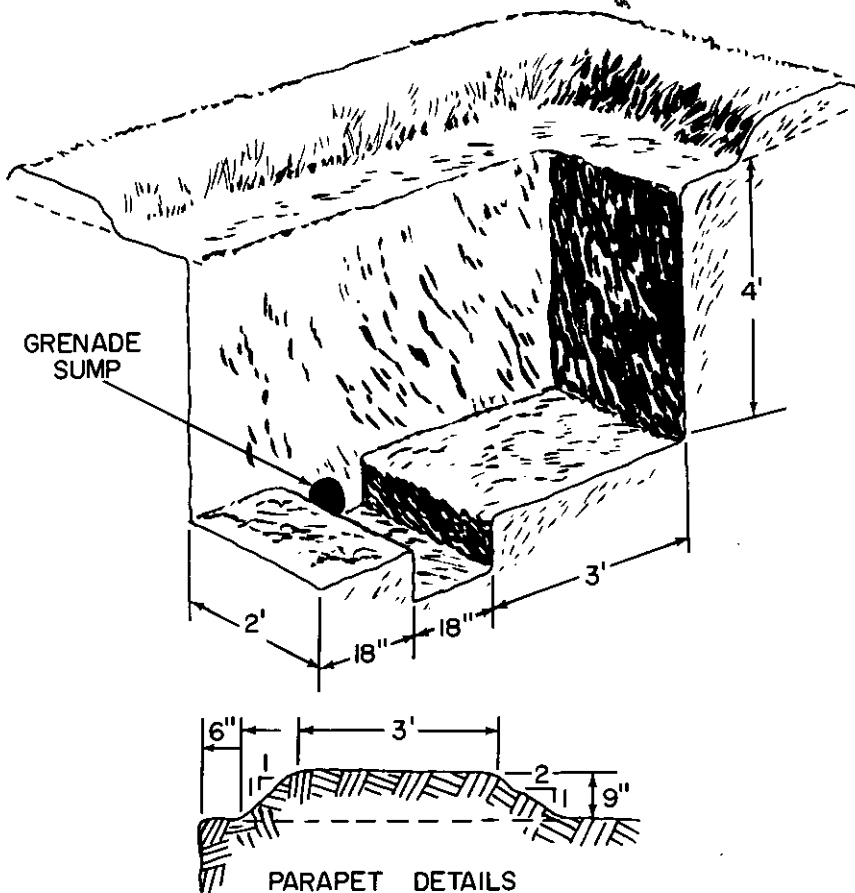

① STANDARD

Figure 29. Open two-man foxhole.

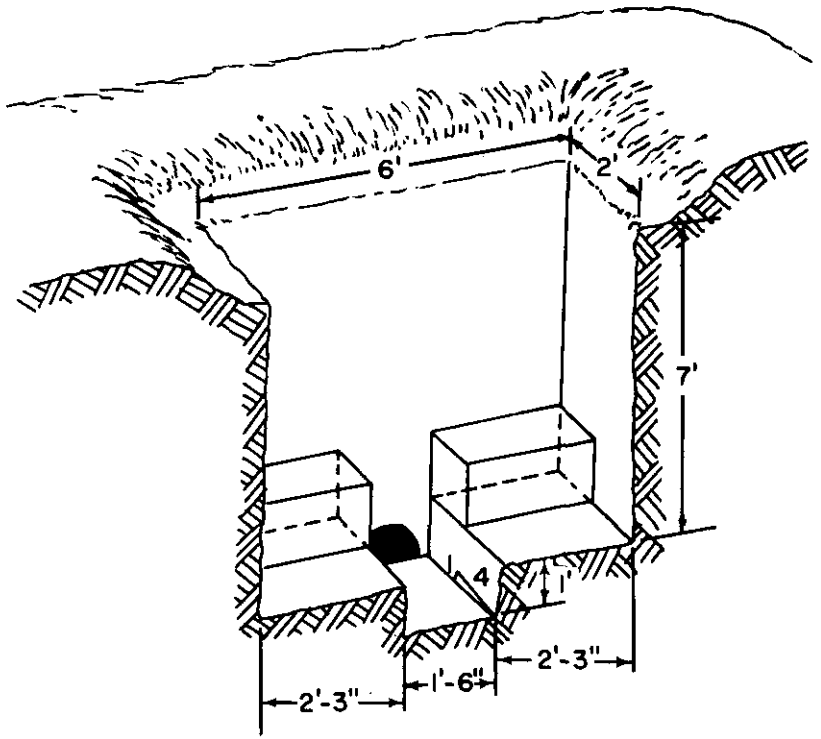

② DEEPENED

Figure 29—Continued.

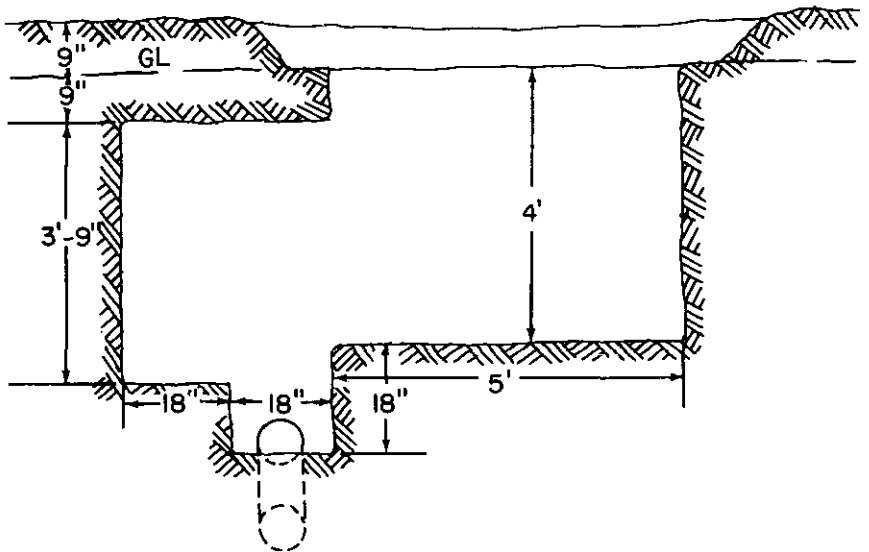

STANDARD

Figure 30. Standard two-man foxhole with half cover.

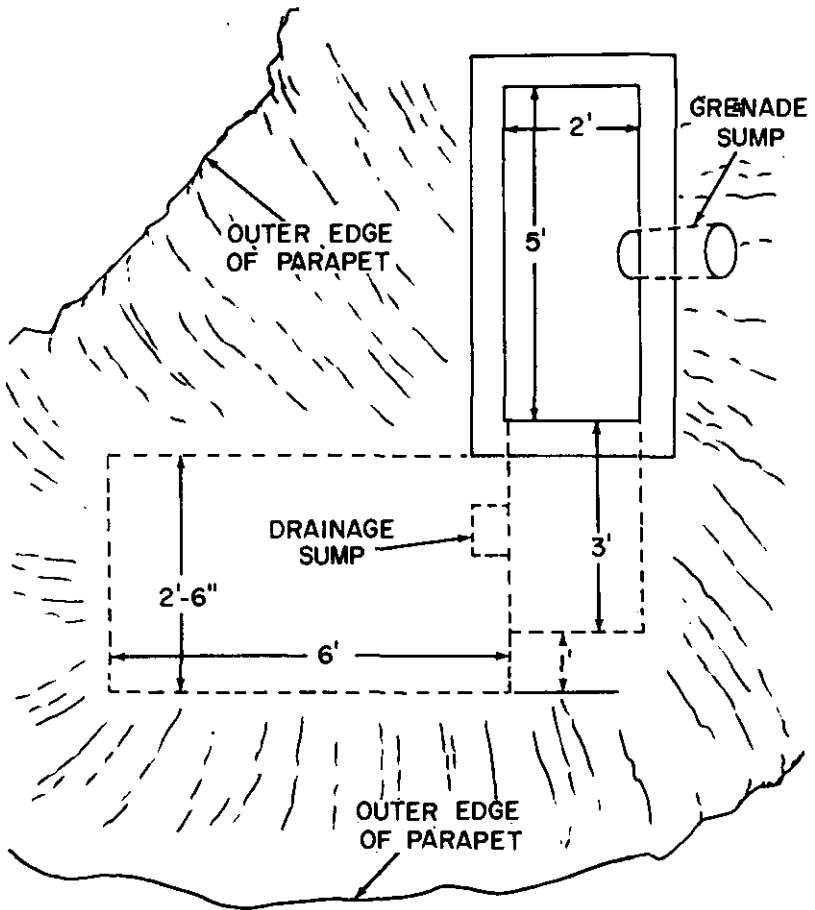

② WITH ADJOINING SHELTER

Figure 31—Continued

- (4) *Overhead cover.* The half overhead cover for the two-man foxhole is constructed in the same fashion as that used on the one-man foxhole.

52. Trenches

a. General. Trenches are excavations of standard dimension used to connect other emplacements and shelters. Trenches are developed progressively from the crawl trench, through the crouch and run trench and the fighting trench, to the standard trench.

b. Crawl Trench. This trench is a shallow trench, providing protection for a crawling man, and is used to connect other emplacements, trenches or shelters. Figure 32 shows the dimensions of a crawl trench.

c. Crouch and Run Trench. This trench is usually developed from

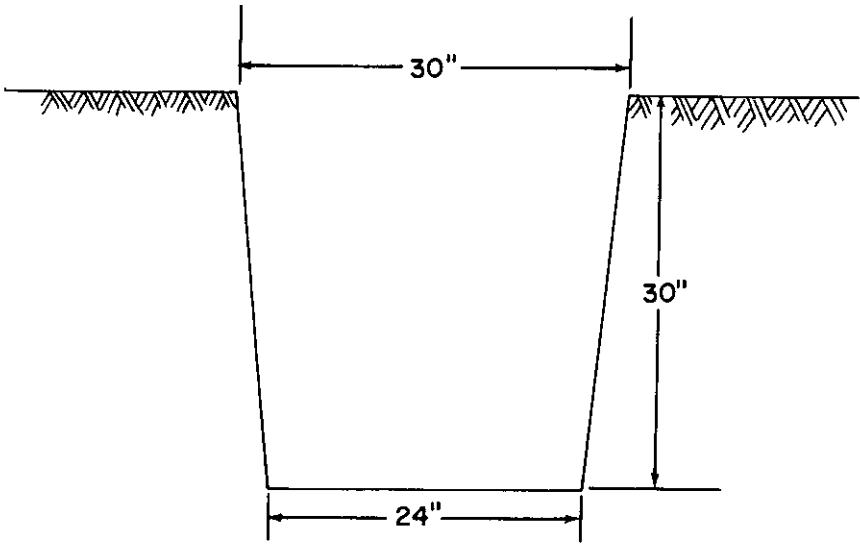

Figure 32. Crawl trench.

a crawl trench. It provides protection for a crouching man and is of a size to permit him to run while taking advantage of the protection of the trench. Its uses are the same as described for the crawl trench. Figure 33 shows the dimensions of a crouch and run trench.

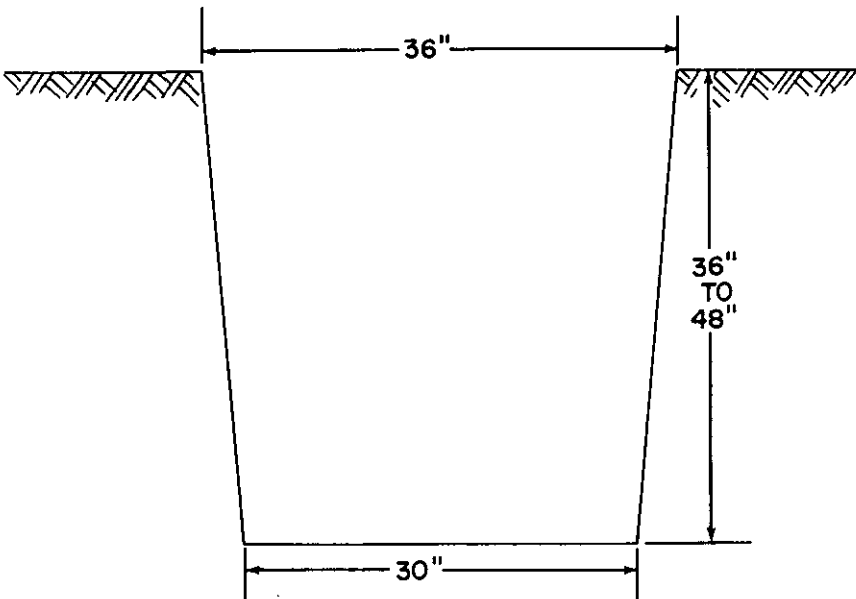

Figure 33. Crouch and run trench.

d. Fighting Trench. This trench is the next stage in the progressive development toward the standard trench. It may be developed from either a crawl trench or a crouch and run trench. Figures 34 to 36 illustrate types of fighting trenches. This trench is normally revetted except when constructed in extremely stable soil. It may be open as shown in figure 34, covered as shown in figure 35, or open with a fighting bay as shown in figure 36. This trench provides limited protection from nuclear weapons effects if the occupants are completely within the trench at the time of the explosion, and fair protection from conventional weapons. It is also a fighting position in that it allows a man to sit or stand in the trench and fire his weapon. This trench increases the flexibility of a position in which it is used in that it offers a means of communication, protection, and an emplacement for fighting. Additional protection can be gained by the construction of a parapet.

e. Standard Trench. The standard trench is developed from the fighting trench by lowering it to a depth of 5½ feet below the ground and constructing a 1 foot parapet above the ground line. It may be constructed without fighting bays as shown in figure 37, with fighting bays, as shown in figure 38 or with a continuous fighting step, as shown in figure 39. This trench provides somewhat greater protection against both conventional and nuclear weapons than the fighting trench as a result of its greater depth and its parapet. It is primarily a fighting position but is also usable for communications control, supply, evacuation, and movement of troops.

f. Protection Afforded. The protection afforded by each of the types of trenches described above is tabulated in table VI.

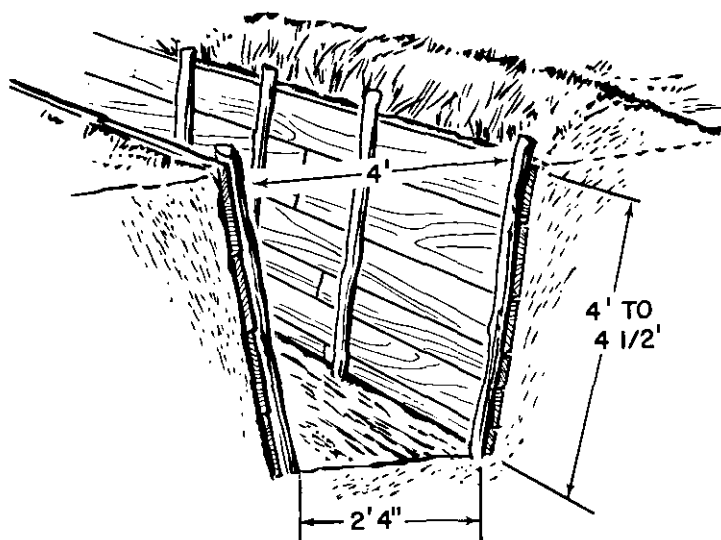

Figure 34. Open revetted fighting trench.

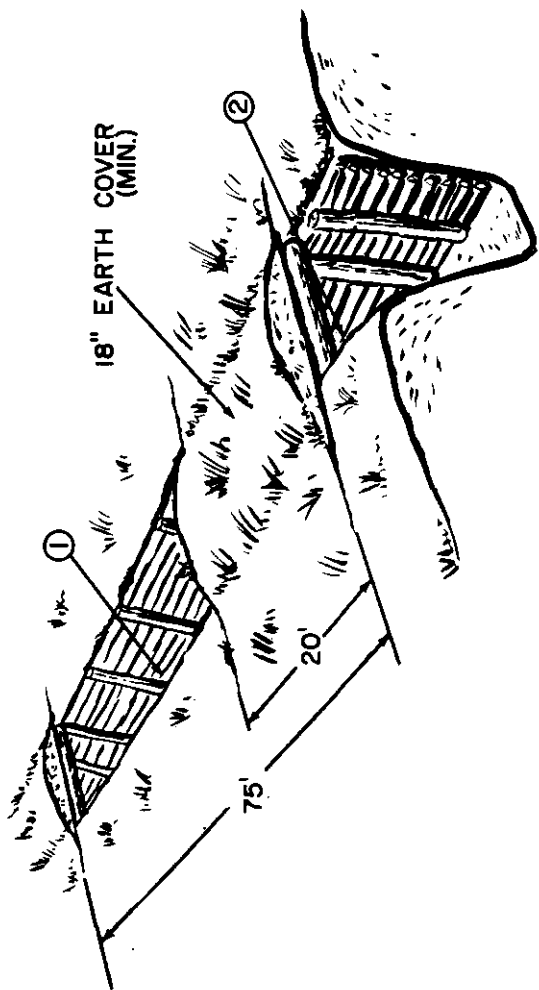

Figure 85. Revetted fighting trench with full cover.

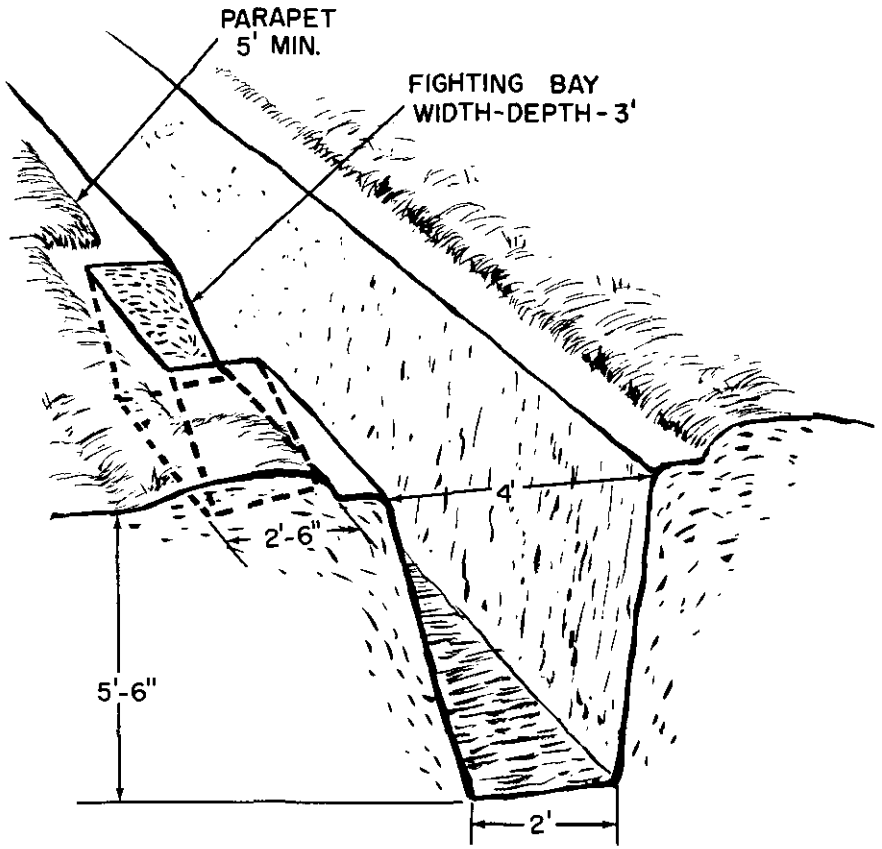

Figure 36. Open revetted fighting trench with fighting bay.

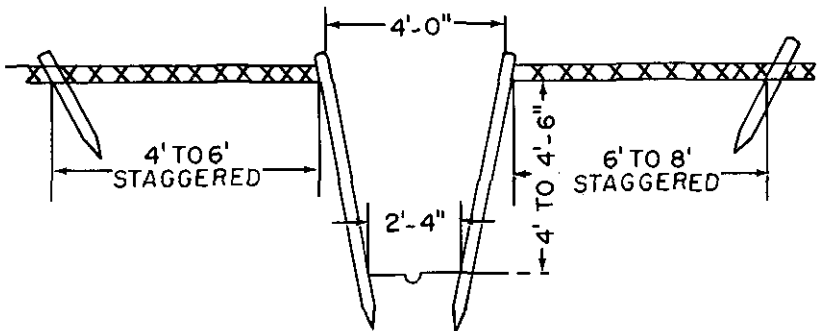
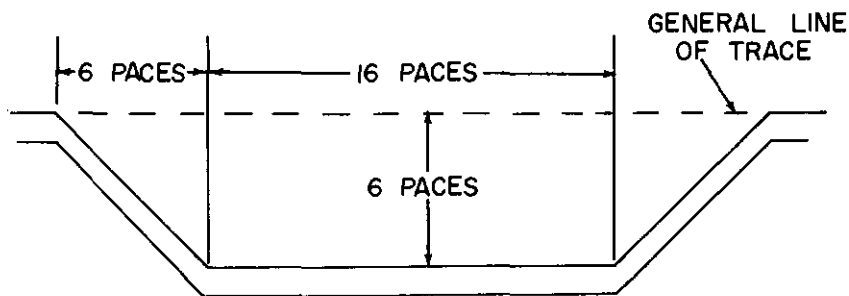
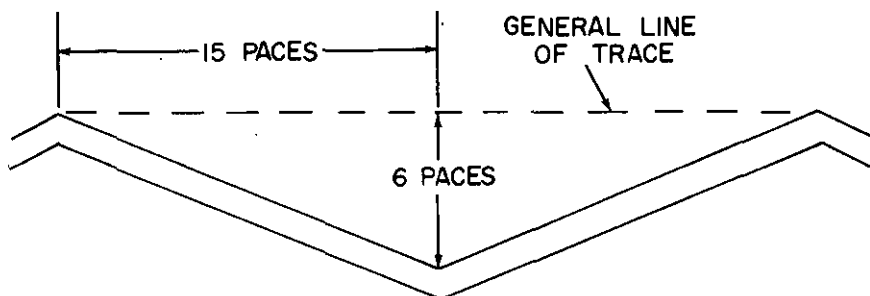

Figure 37. Standard trench without fighting bays.



① OCTAGONAL TRACE



② ZIGZAG TRACE

Figure 40. Standard trench traces.

- (e) It can be provided with a continuous fire step. Its chief disadvantage is that its layout lacks simplicity of detail.
- (2) *Zigzag trace.* The zigzag trace, 2, figure 40, can provide protection from enfilade fire and shell bursts by the employment of short tangents and by the occupation of alternate tangents. The zigzag trace has the following advantages:
- (a) It is the simplest and easiest to trace, construct, revet, and maintain.
 - (b) It may be readily adapted to the terrain.
 - (c) It permits both frontal and flanking fire. This trace has no specific disadvantages.

i. Trench Boards. As noted in paragraph 47, trenches are sloped longitudinally for drainage. Trench bottoms are grooved or cut V-shaped to carry water, and trench boards, as shown in figure 41, are installed to provide a surface for walking. If lumber is not available,

logs and branches may replace the stringers and slats. Coarse gravel or crushed rock may be used instead of stringers if the flow of water is small, with a plank to serve as a walkway.

j. Overhead Cover. If overhead cover is used in the construction of trenches, it should be installed in 20- to 40-foot sections and in conjunction with the overhead cover of emplacements and shelters connected by the trenches. Sections of cover should also be constructed and camouflaged at random along the trench trace to deceive the enemy as to the true location of the position. Support for light overhead cover is constructed as described in paragraph 40. Support for heavy overhead cover is furnished by post-cap-stringer type structures as shown in figures 42 and 43.

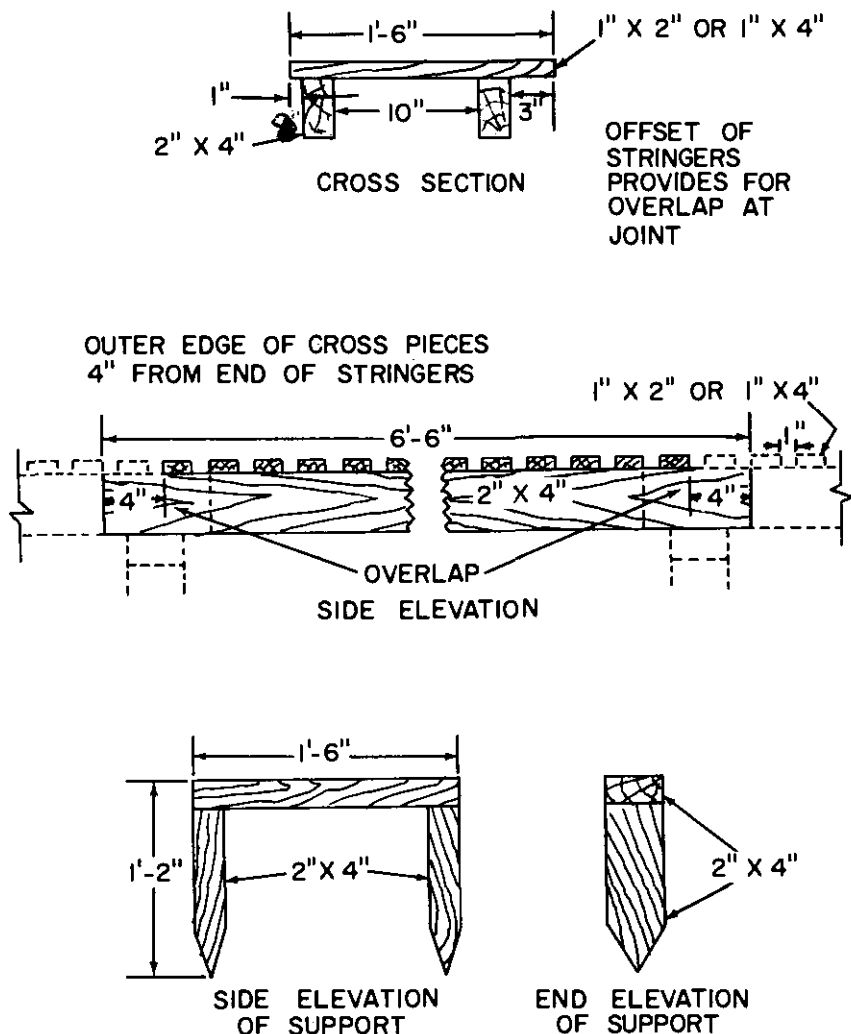
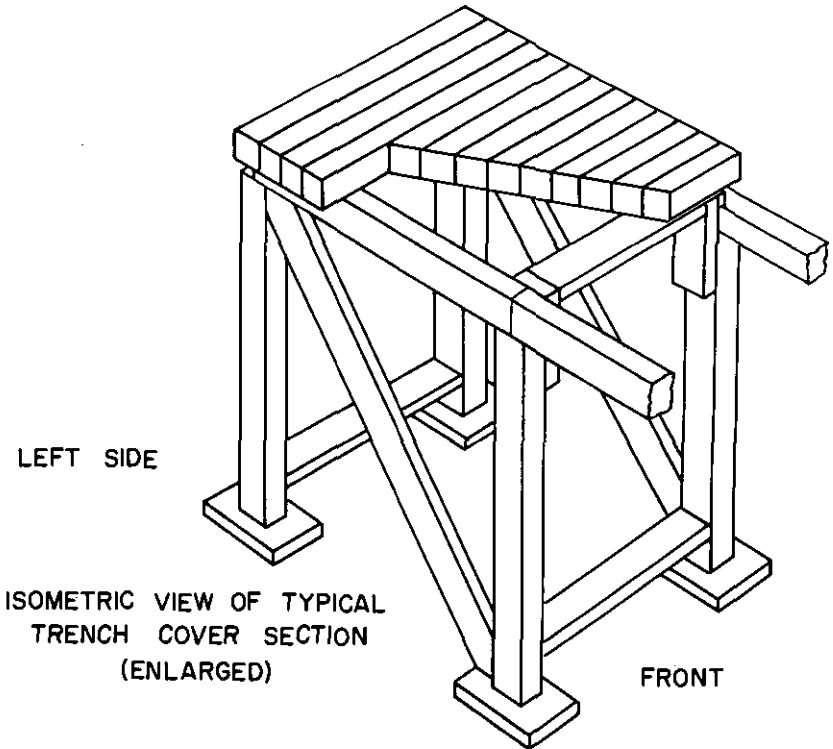

Figure 41. Trench board and support.



BRACING DETAILS

CROSS BRACING SHOULD BE USED ON END SECTIONS OF TRENCH COVER. IF THE PORTION OF THE TRENCH TO BE COVERED REQUIRES FIVE OR MORE TYPICAL SECTIONS (30' OR GREATER) THE CENTER SECTION SHOULD ALSO BE CROSS.

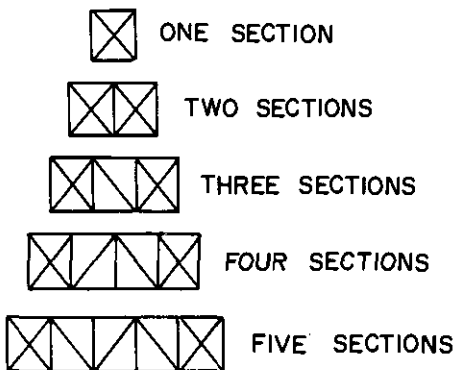
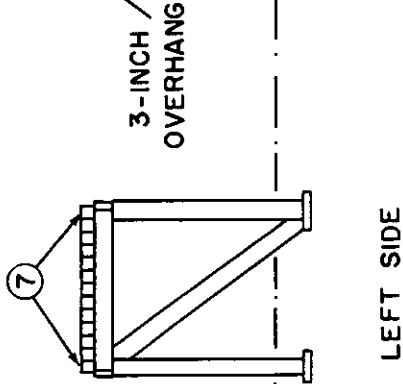
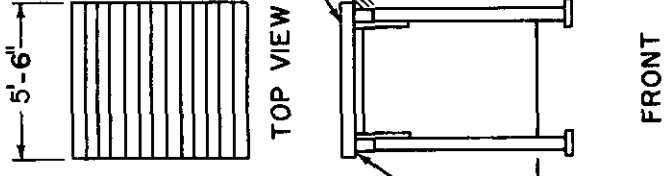
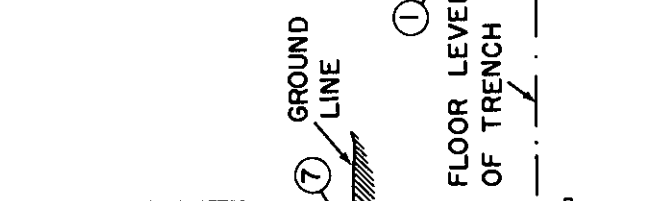
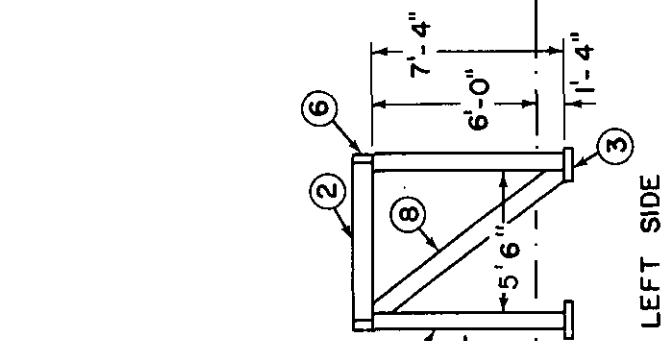
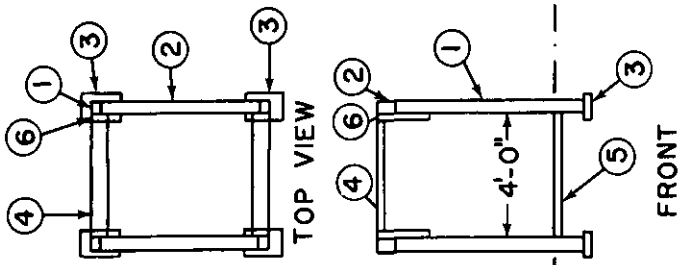

Figure 42. Trench cover section, dimensioned timber.



FRAMING DETAILS

FRAME WITH ROOF

Figure 42—Continued.

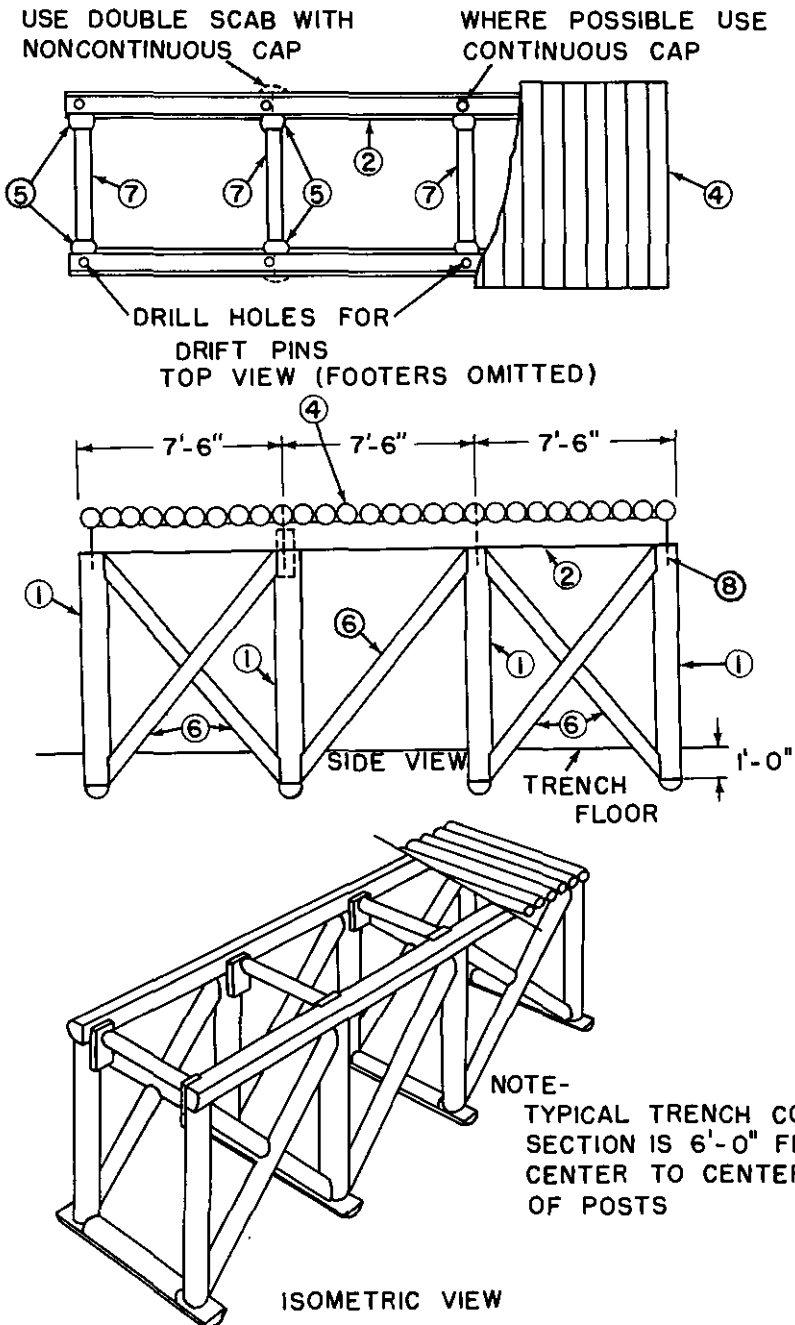
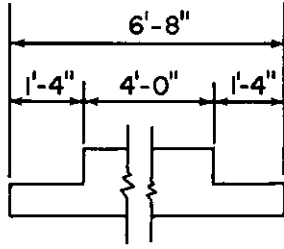
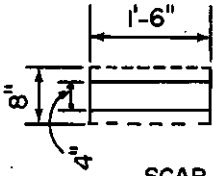

Figure 43. Trench cover section, log construction.



FOOTING & SILL DETAIL

BOTH LOGS OF THE
CROSS BRACING IDENTICALLY
NOTCHED



SCAB DETAIL

CUT ALONG LINES

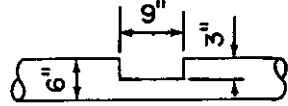

CROSS BRACING DETAIL

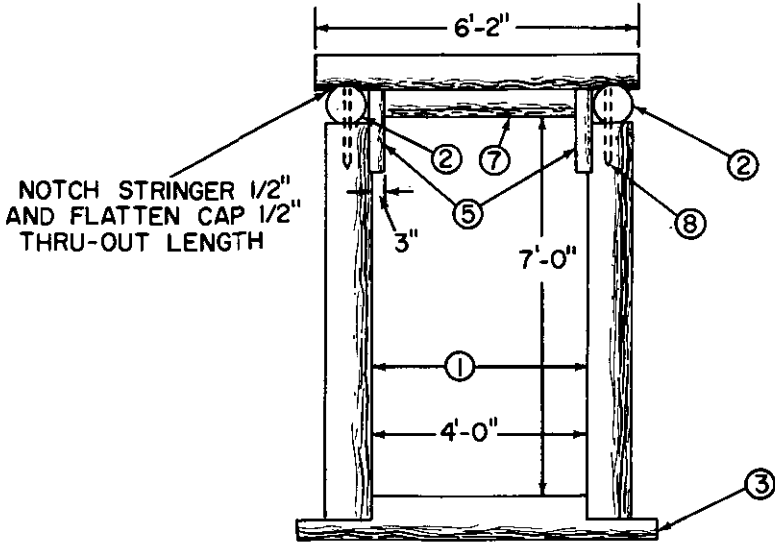

NOTCH STRINGER 1/2"
AND FLATTEN CAP 1/2"
THRU-OUT LENGTH

END VIEW

Figure 43—Continued.

The bills of materials and construction notes are shown in table IV for the dimensioned timber structure and in table V for the log structure.

53. Progressive Development

Emplacements for the protection of personnel and individual weapons normally progress from the improved crater through the skirmishers trench, the prone emplacement and the one- and two-man foxholes with their various refinements, as described in paragraphs 50 and 51. Trenches, developed as described in paragraph 52, may be used at any stage of emplacement development. Other factors which may dictate the skipping of certain intermediate phases of development are presented in table VI. This table allows the selection of the most appropriate emplacement for a given protective requirement and further determination of the best sequence of progressive development based on the amount of protection achieved for a given expenditure of manpower and logistic effort.

Table IV. Bill of Materials, Trench Cover Section, Post, Cap, and Stringer Construction Dimensioned Timber (fig. 42)

| No. | Nomenclature | Size | Basic section as shown | Additional sections when used in series |
|-----|----------------------|------------------|------------------------|---|
| 1 | Post..... | 8" × 8" × 7'-4" | 4 | 2 |
| 2 | Cap..... | 8" × 10" × 6'-2" | 2 | 2 |
| 3 | Footing..... | 2" × 8" × 1'-4" | 16 | 8 |
| 4 | Top spreader..... | 3" × 8" × 3'-6" | 2 | 1 |
| 5 | Bottom spreader..... | 3" × 8" × 4'-0" | 2 | 1 |
| 6 | Scab..... | 3" × 8" × 2'-0" | 4 | 2 |
| 7 | Stringer*..... | 6" × 8" × 5'-10" | 13 | 13 |
| 8 | Bracing..... | 3" × 8" × 9'-6" | 2** | 2** |
| 9 | Driftpin..... | ¾" × 16" | 8 | 4 |
| 10 | Driftpin..... | ½" × 12" | 26 | 24 |
| 11 | Nails..... | 60d | 20 lb | 15 lb |

* Laminated wood roof, designed in accordance with table II may be substituted if desired.

** Change to 4 when cross bracing is required. See bracing details.

Suggested Construction Procedure

1. Dig holes for footers.
2. Place footers in holes making them as level as possible.
3. Nail posts to footers.
4. Place caps on top of posts and secure with driftpins (bore ½" holes for pins).
5. Nail scabs in place.
6. Nail top and bottom spreaders in place.
7. Nail side braces in place.
8. Put stringers on top of caps and secure with ½" driftpins.
9. Use typical overhead cover.

Table V. Bill of Materials, Trench Cover Section, Post, Cap, and Stringer, Log Construction (fig. 43)

| No. | Nomenclature | Size | Basic section as shown | Additional sections when used in series |
|-----|-------------------|--------------------|------------------------|---|
| 1 | Post..... | 12" log × 7'-4" | 4 | 2 |
| 2 | Cap..... | 12" log × 7'-6"* | 2 | 2 |
| 3 | Sill..... | 12" log × 6'-4" | 2 | 1 |
| 4 | Stringer***..... | 10" log × 6'-4" | 8 | 8 |
| 5 | Scab..... | 3" × 8" × 1'-6"*** | 4 | 2 |
| 6 | Bracing..... | 6" log × 9'-6" | 4 | 4 |
| 7 | Top spreader..... | 6" log × 3'-6" | 2 | 1 |
| 8 | Driftpins..... | ½" × 16" | 30 | 18 |
| 9 | Nails..... | 100d | 8 lb | 8 lb |
| 10 | Nails..... | 60d | 20 lb | 18 lb |

* Or larger multiples thereof.

** Scab should be dimension timber as indicated, whenever such material is available. When only logs are available the scab should be split out of the center of an 8" log.

*** Laminated wood roof, designed in accordance with table I, may be substituted if desired.

Construction Notes

1. Dig trenches for sills.
2. Place sills and level up.
3. Nail posts to sills with 100d nails.
4. Place caps on posts, secure with driftpins.
5. Nail scabs in place.
6. Nail in top spreaders.
7. Nail cross bracing in place.
8. Place stringers on top of caps and secure with ½" driftpins.
9. Use typical overhead cover.

Table VI. Characteristics of Personnel and Individual Weapons Emplacements

| Type of emplacement or shelter | Nuclear weapons effects ¹ | | | Conventional weapons effects ¹ | | | Total construction time in man hours for construction with D-handle shovels and ordinary carpentry tools ² | | | Weight and volume of materials | | | | | |
|---|--------------------------------------|-----------------|-----------------------------|---|-----------------|---------------------|---|---|---------------------|--------------------------------|--|---------------------------|--|---------------------------|---------------------|
| | Initial gamma | Initial neutron | Residual gamma ³ | Fortification protection factor | Thermal effects | Tracked vehicles | Artillery fragments | Revertment materials for cover support only | Complete revertment | No revertment materials used | Corrugated metal construction ⁴ | Sized lumber construction | Corrugated metal construction ⁴ | Sized lumber construction | Complete revertment |
| Improved crater..... | 0.6 | 0.8 | 0.3 | 90 | Fair..... | Virtually none..... | Better than in open..... | N/A | N/A | 0.5 | N/A | N/A | N/A | N/A | N/A |
| Skirmishers trench..... | 0.8 | 0.9 | 0.5 | 95 | Fair..... | Virtually none..... | Better than in open..... | N/A | N/A | 0.5 | N/A | N/A | N/A | N/A | N/A |
| Prono emplacement..... | 0.4 | 0.7 | 0.2 | 85 | Good..... | Virtually none..... | Fair..... | N/A | N/A | 1.5 | N/A | N/A | N/A | N/A | N/A |
| Open one man foxhole..... | 0.09 | 0.3 | 0.1 | 65 | Very good..... | Good..... | Good..... | N/A | N/A | 2.0 | N/A | N/A | N/A | N/A | N/A |
| Open one man foxhole with offset..... | 0.004 | 0.008 | 0.00001 | 20 | Excellent..... | Very good..... | Excellent..... | 9.0 | 14.0 | N/A | 16.0 | N/A | 5.5 | 24.0 | 4.0 |
| One man foxhole with half cover..... | 0.08 | 0.2 | 0.04 | 55 | Very good..... | Fair (-)..... | Very good..... | 2.5 | 3.0 | N/A | 4.5 | 5.5 | N/A | 20.0 | 3.5 |
| One man foxhole with half cover and offset..... | 0.003 | 0.008 | 0.00001 | 20 | Excellent..... | Very good..... | Excellent..... | 10.0 | 14.0 | N/A | 12.0 | 18.0 | N/A | 25.0 | 4.0 |
| Open two man foxhole..... | 0.1 | 0.3 | 0.1 | 65 | Good..... | Good..... | Good..... | N/A | N/A | 3.0 | N/A | N/A | N/A | 28.0 | 10.0 |
| Deepened two man foxhole..... | 0.07 | 0.15 | 0.1 | 55 | Very good..... | Good..... | Very good..... | N/A | N/A | 5.0 | N/A | 10.0 | N/A | 30.0 | 12.0 |
| Two man foxhole with half cover..... | 0.09 | 0.2 | 0.04 | 60 | Very good..... | Fair to good..... | Very good..... | 4.0 | 4.0 | N/A | 8.0 | 10.0 | N/A | 28.0 | 11.0 |
| Two man foxhole with half cover and two offsets..... | 0.002 | 0.003 | 0.00001 | 15 | Excellent..... | Very good..... | Excellent..... | 20.0 | 30.0 | N/A | 22.0 | 35.0 | N/A | 38.0 | 22.0 |
| Two man foxhole with half cover and adjoining shelter..... | 0.01 | 0.02 | 0.0005 | 30 | Excellent..... | Good..... | Excellent..... | 11.0 | 17.0 | N/A | 13.0 | 22.0 | N/A | 46.0 | 28.0 |
| Open fighting trench (25' length) ⁵ | 0.4 | 0.7 | 0.3 | 85 | Good..... | Fair..... | Good..... | N/A | N/A | 21.0 | N/A | 32.0 | N/A | 49.0 | 22.0 |
| Fighting trench with full cover (25' length) ⁵ | 0.15 | 0.4 | 0.03 | 70 | Excellent..... | Fair..... | Very good..... | 27.0 | 29.0 | N/A | 35.0 | 40.0 | N/A | 73.0 | 33.0 |

¹ Protection afforded assumes the occupants of fortifications are in the most protected position of their fortifications. For most fortifications protection decreases as the angle of sight from the position to the center of the weapon burst increases.

- ² a. For blast effects, see paragraph 16.
- ³ a. For direct fire weapons effects, see paragraph 9.
- ⁴ b. For base combat weapons effects, see paragraph 7.
- ⁵ Assumes normal digging capability in daylight with trained troops.
- ⁶ Assumes fallout is kept out of hole at surface level by some sort of cover.
- ⁷ May include wooden framing and braces.

Note: Classification of Fortifications by Attenuating of Residual Radiation.

a. Fortifications may be generally classified according to their attenuation of residual radiation. Such classification is shown below:

| Transmission Factors | Fallout Attenuation Classifications | General Guidance in High Level Radiation Field |
|----------------------|-------------------------------------|--|
| Less than 0.001..... | Excellent | Remain in place |
| 0.001 to 0.005..... | Good | Probably remain in place |
| 0.005 to 0.01..... | Fair | Probably leave position at optimum time. |
| More than 0.01..... | Poor | Leave position at optimum time. |

b. A general idea of the dose to be expected with the classifications shown above is tabulated below, using a fallout arrival time of H+1 and a stay time of 96 hours. Under these conditions, the total incident dose in rem is exactly three times the dose rate of H+1. Assuming an H+1 dose of 5,000 rem, hour:

| Classification | Interior Dose for Various Fallout Classifications* | Total Dose |
|----------------|--|--------------------|
| Excellent..... | Less than 15 rem* | Less than 15 rem* |
| Good..... | 15 to 75 rem* | 15 to 75 rem* |
| Fair..... | 75 to 150 rem* | 75 to 150 rem* |
| Poor..... | More than 150 rem* | More than 150 rem* |

*See conditions in appendix II on fortification protection factor.

Section II. SHELTERS

54. General

A shelter, either natural or artificial, provides protection for troops, supplies, and equipment from either enemy action, weather, or both. Shelters may be open or covered. Shelters differ from emplacements in that no provision is made for firing weapons from them. Although natural shelters, such as caves, mines and tunnels, as well as artificial shelters may be used by troops in the field, the discussion in this section is limited to artificial shelters. Artificial shelters may be constructed as surface or subsurface shelters. Subsurface shelters may either be of the open cut, cut and cover, or cave type. The type to be constructed in a given situation is determined by the character of the ground, the intended use, the materials available, and the protection required.

55. Surface Shelters

a. General. Surface shelters provide the best observation, and exit and require the least amount of labor to construct. They are difficult to conceal, require transportation or local procurement of considerable quantities of cover and revetting materials, and provide the least protection of the types of shelters discussed in this manual. These shelters are seldom used to provide protection for personnel in forward positions unless they can be concealed in woods, on reverse slopes, or among buildings. They may be used when the water level is so close to the surface or the surface is so hard or frozen that the construction of the cut and cover type of shelter is not practical. Surface shelters should be of small capacity (2-12 men) and well dispersed.

b. Wooden Surface Shelter (fig. 44). This shelter will not provide good protection against either nuclear weapons effects or direct hits from artillery, bombs, or heavy rockets. Blast, particularly from the direction of the doorway, would probably destroy the structure in overpressures ranging from 5 to 10 psi, depending on the shape of the structure. Radiation transmission factors have been determined for this shelter with 1½ feet, 2½ feet, and 3½ feet of earth cover overhead. For initial gamma and residual radiation, transmission factors are as shown in table VII for an occupant at the center of the shelter.

Table VII. Radiation Transmission Factors for Wooden Surface Shelters

| Earth cover thickness | Initial gamma | Residual |
|-----------------------|---------------|----------|
| 1½ feet | 0.20 | 0.02 |
| 2½ feet | 0.08 | 0.009 |
| 3½ feet | 0.04 | 0.004 |

Table 6-5, TM 23-200 is the best guide currently available for determining initial neutron transmission factors giving a range of 0.08 to 0.01 for 2 to 3 feet of earth cover. Another fair approximation is to consider that neutron transmission factors are equal to, or slightly less than, prompt gamma transmission factors. These factors could be improved by putting in a baffled entranceway, but blast would normally be prohibitively destructive at fairly long ranges making such added radiation protection of little value.

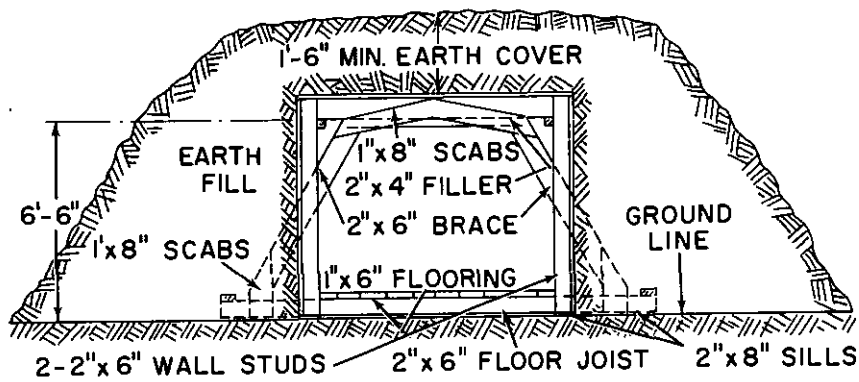

① CROSS SECTION

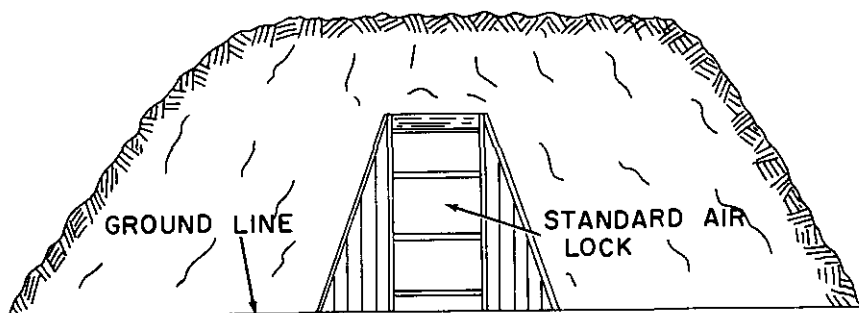

② FRONT ELEVATION

Figure 44. Wooden surface shelter.

c. Metal Surface Shelter. Such shelters are superior to wooden surface shelters in that they are readily adaptable to arched configurations, are more rapidly erected, and generally present streamlined targets. The arched or cylindrical shape resists nuclear weapons blast better than a rectangular shape. The 9 foot corrugated metal surface will protect against blast pressures of from 15 to 25 psi. The initial gamma and residual radiation transmission factors for 1½ feet, 2½ feet, and 3½ feet of earth cover are shown in table VIII.

Table VIII. Radiation Transmission Factors for Metal Surface Shelters

| Earth cover thickness | Initial gamma | Residual |
|-----------------------|---------------|----------|
| 1½ feet | 0.10 | 0.015 |
| 2½ feet | 0.07 | 0.004 |
| 3½ feet | 0.03 | 0.003 |

The best estimate for initial neutron radiation transmission factors is that they are equal to, or slightly less than, the values for prompt gamma radiation. A baffled entranceway will significantly improve transmission factors, especially as the overhead earth cover thickness is increased.

d. Use. The surface shelter is most suitable for use in rear areas where protected working space for an installation is needed.

56. Subsurface Shelters

a. General. This type of shelter generally provides better protection than the surface shelter. Since it is below the surface it is not subject to the drag loading of the blast effects (although personnel inside might be if entrance design permits entry of the blast wave).

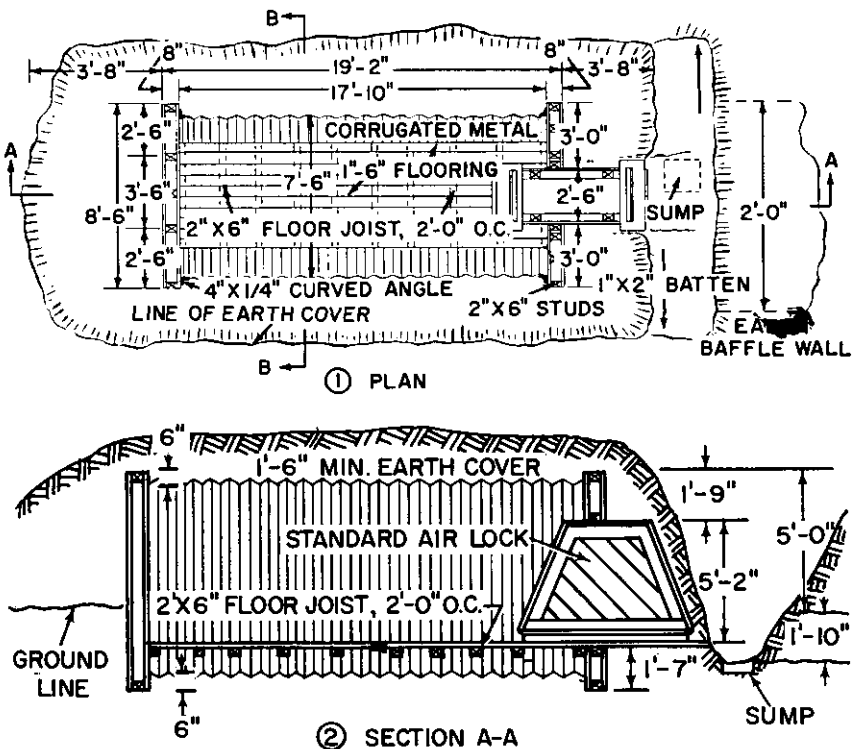

Figure 45. Metal surface shelter.

END WALLS SHEATHED ON BOTH SIDES. 1" X 6" INTERIOR SHEATHING
 HORIZONTAL, EXTERIOR DIAGONAL.
 TARPAPER OUTSIDE

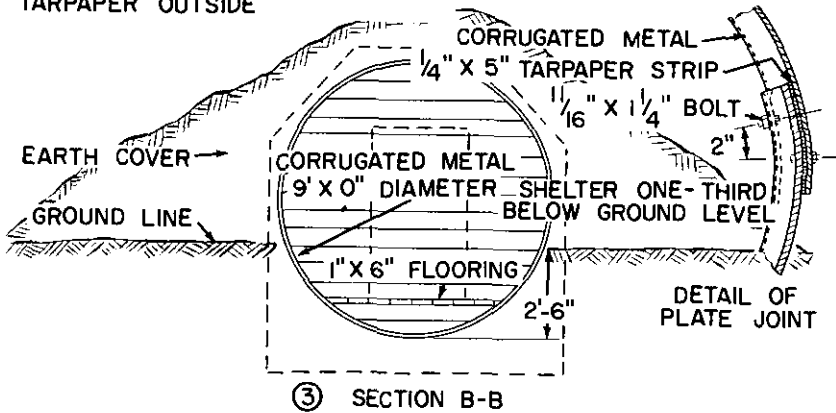

Figure 45—Continued.

It can, therefore, withstand much higher pressures than the surface shelter. Also, protection against radiation is improved since the surrounding earth will provide somewhat more protection than would the limited thicknesses around a surface shelter. Its below the surface location also increases protection against conventional weapons effects, by providing ample overhead cover to prevent penetration by direct fire weapons, fragments or airplane rockets, except those from directly above the shelter. There is usually no silhouette to serve as a target for direct fire weapons other than the sloped overhead cover. Special consideration should be given to entranceway design. A line of sight from the inside to the outside of the shelter will result in a considerable reduction of protection against radiation. One or two right angle turns, or offsets, in an entranceway provide good protection.

b. Offset Foxhole With Two-Man Shelter. Two types of subsurface shelters were previously covered in section I emplacements. One is the offset foxhole when it is not designed to be used as a fighting emplacement. The second is the two-man shelter for use in conjunction with the foxhole.

c. Open Cut. Where it is necessary to provide protection for a relatively large number of personnel in a relatively short period of time, the use of an open excavation as shown in figure 46 will provide some protection against small arms, direct fire artillery weapons, and the effects of nuclear weapons. The amount of protection against the latter is dependent on the location of ground zero with respect to the shelter and the height of the burst.

d. Cut and Cover. Cut and cover shelters are the type most commonly employed in a forward area. An excavation is dug into the ground, the shelter is erected in the excavation, and the spoil is back

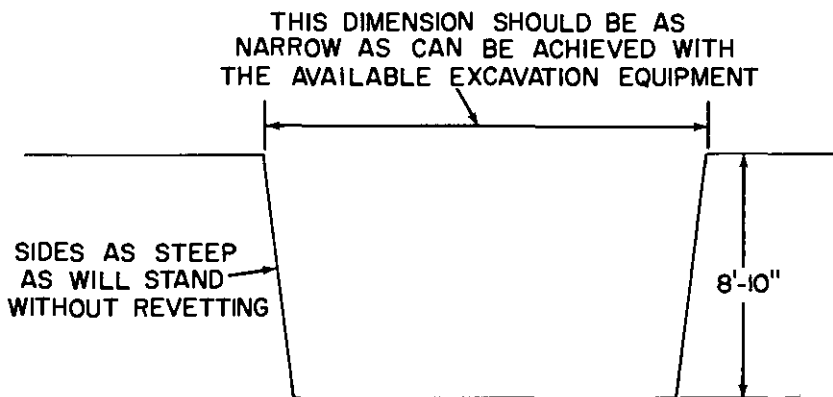

Figure 46. Open cut subsurface shelter.

filled around and over it to or above ground level. The shelter may be constructed of local material, dimension lumber, timber, or corrugated metal. The protection provided depends on the type of construction, thickness, and composition of the overhead cover. Cut and cover shelters are especially suitable as command posts and aid stations, since they are easily cleaned and ventilated and casualties can easily be admitted and evacuated. For drainage, the floor of the shelter should slope slightly toward the entrance. Excavation should be no greater than is necessary to accommodate the structure, and the excavated dirt should be packed around the structure. The static load of the overhead cover plus the assumed impact load should not be greater than the structure can support.

- (1) *Modular timber shelter* (fig. 47). This shelter with dimensions of 6 feet by 8 feet can be made from finished timber with varying degrees of protection depending on the size of members used and the type of construction. Radiation protection is almost independent of the type of frame roof and revetment construction but depends on the thickness of overhead cover and overall configuration. For an individual 6 foot by 8 foot shelter, with well-baffled entranceways, transmission factors vary with the thickness of earth overhead cover as shown in table IX.

Table IX. Radiation Transmission Factors for Subsurface Modular Timber Shelter

| Earth overhead cover thickness | Initial gamma | | Residual |
|--------------------------------|---------------|-----------|------------|
| | Surface burst | Air burst | |
| 1½ feet | .09 | .15 | .004 |
| 2½ feet | .05 | .07 | .0002 |
| 3½ feet | .03 | .04 | negligible |

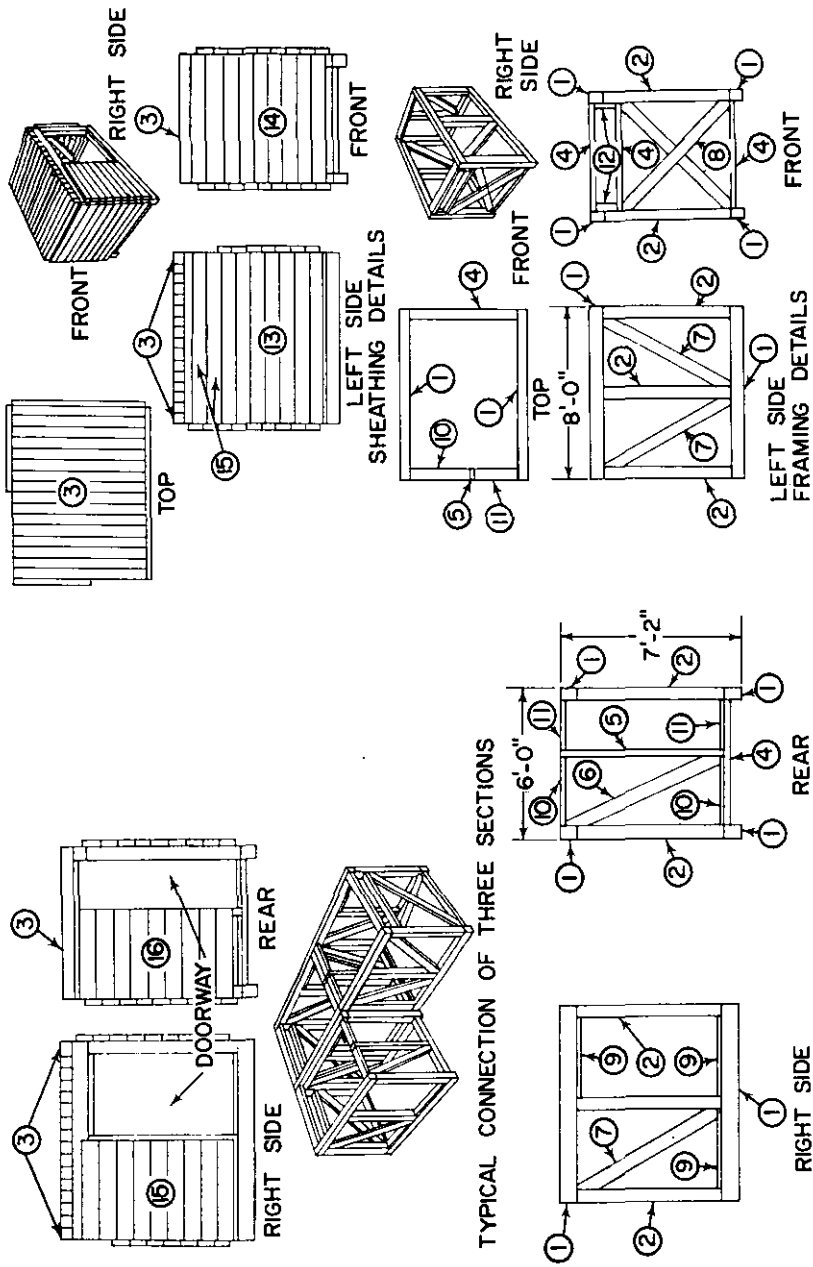

Figure 47. Modular timber shelter (6 feet by 8 feet).

An approximation for the initial neutron radiation transmission factor is a figure slightly less than that for corresponding initial gamma. Protection against blast will vary from about 30 psi for light construction up to 65 psi for heavy post-cap-stringer type construction for a shelter with about 2 to 4 feet of earth overhead cover.

- (2) *Corrugated metal arch shelter* (fig. 48). Radiation transmission factors for this shelter, with well-baffled entranceways is as shown in table X.

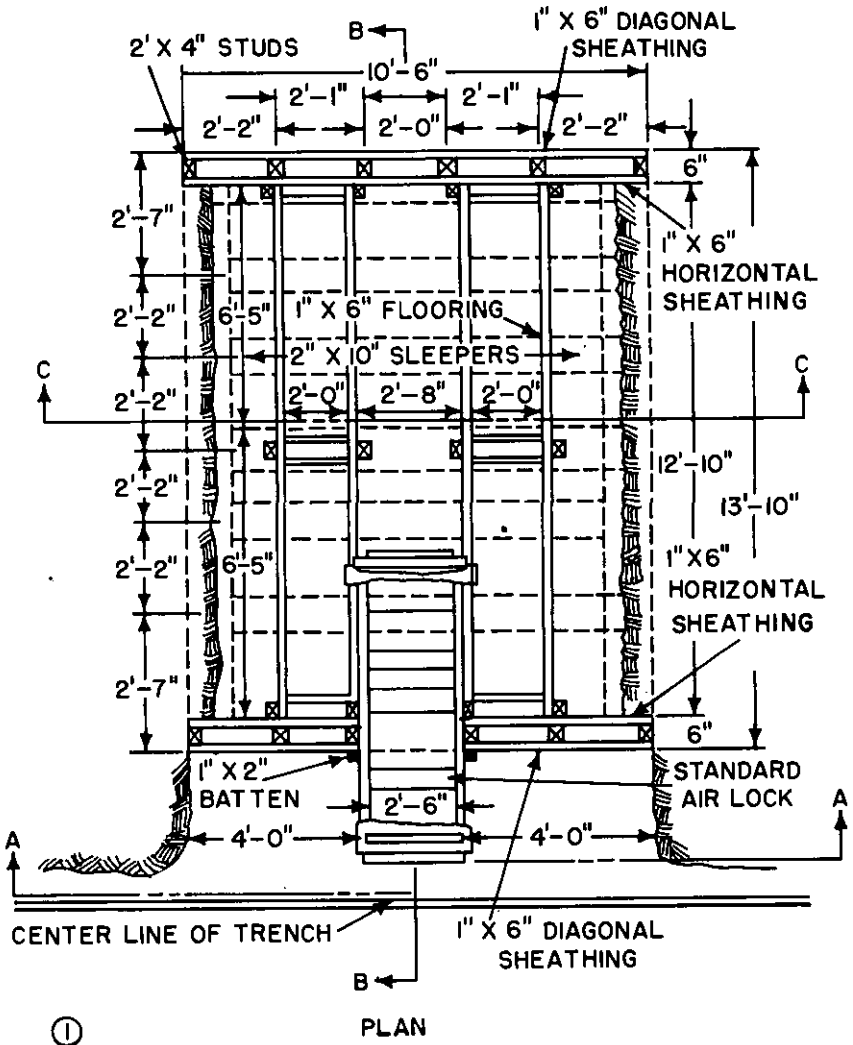
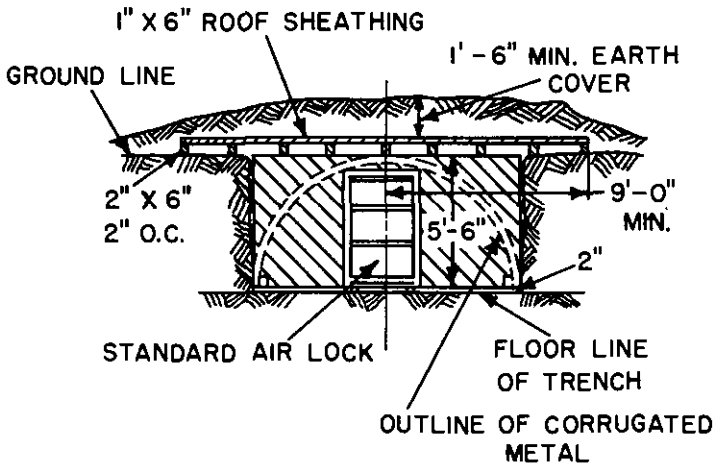
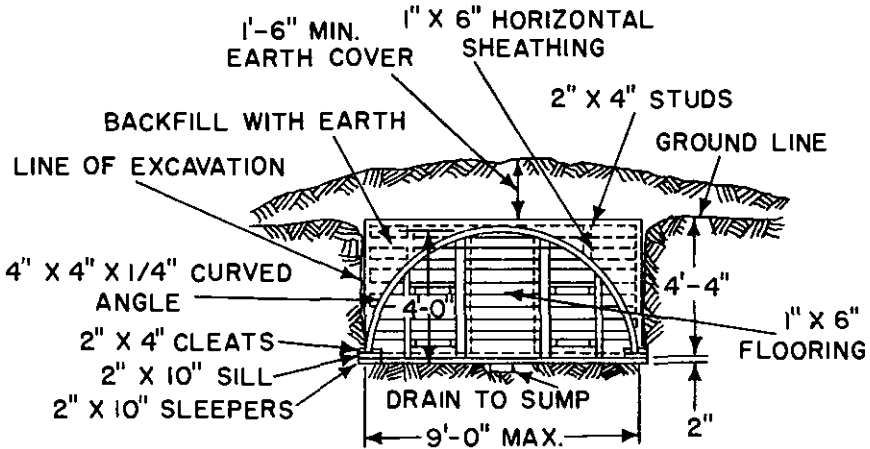

Figure 48. Cut and cover corrugated metal arch shelter.



② FRONT VIEW



③ SECTION ON LINE "C-C"

Figure 48—Continued.

Table X. Radiation Transmission Factors for Subsurface Corrugated Metal Arch Shelter

| Earth overhead cover thickness | Initial gamma | | Residual |
|--------------------------------|---------------|-----------|------------|
| | Surface burst | Air burst | |
| 1½ feet | .06 | .15 | .008 |
| 2½ feet | .015 | .04 | .0002 |
| 3½ feet | .005 | .02 | negligible |

An approximation for the initial neutron radiation transmission factor is a figure slightly less than that for corresponding initial gamma. This same type shelter with larger overall dimensions may be used in administrative support installations. For a shelter 40 feet long and 18 feet wide, transmission factors are as shown in table XI (again, initial neutron transmission factors can be taken as slightly less than the corresponding initial gamma factors).

Table XI. Radiation Transmission Factors for 40 Feet by 18 Feet Subsurface Corrugated Metal Arch Shelter

| Earth overhead cover thickness | Initial gamma | | Residual |
|--------------------------------|---------------|-----------|------------|
| | Surface burst | Air burst | |
| 1½ feet | .06 | .15 | .006 |
| 2½ feet | .015 | .04 | .0003 |
| 3½ feet | .005 | .015 | negligible |

A shelter this size has about 4 times the area of one 9½ feet wide by 20 feet long and is more economical to construct than four 9½ by 20 feet shelters, providing the proper equipment for excavation and erection is available. This type shelter, with a diameter of 9½ feet, will provide protection against blast pressures up to 65 psi with about 2 feet of earth cover. Increasing the depth of the shelter will slightly improve the blast protection it affords.

- (3) *Corrugated metal circular shelter* (fig. 49). This type shelter will provide about the same blast protection as the arch shelter above. A circular shelter 7½ feet in diameter by 20 feet long with well-baffled entranceways will have radiation transmission factors as shown in table XII. (Initial neutron transmission factors can be taken as slightly less than those for initial gamma.)

Table XII. Radiation Transmission Factors for Subsurface 7½ Feet in Diameter by 20 Feet Long Corrugated Metal Circular Shelter

| Earth overhead cover thickness | Initial gamma | | Residual |
|--------------------------------|---------------|-----------|------------|
| | Surface burst | Air burst | |
| 1½ feet | .05 | .1 | .005 |
| 2½ feet | .01 | .03 | .0002 |
| 3½ feet | .004 | .01 | negligible |

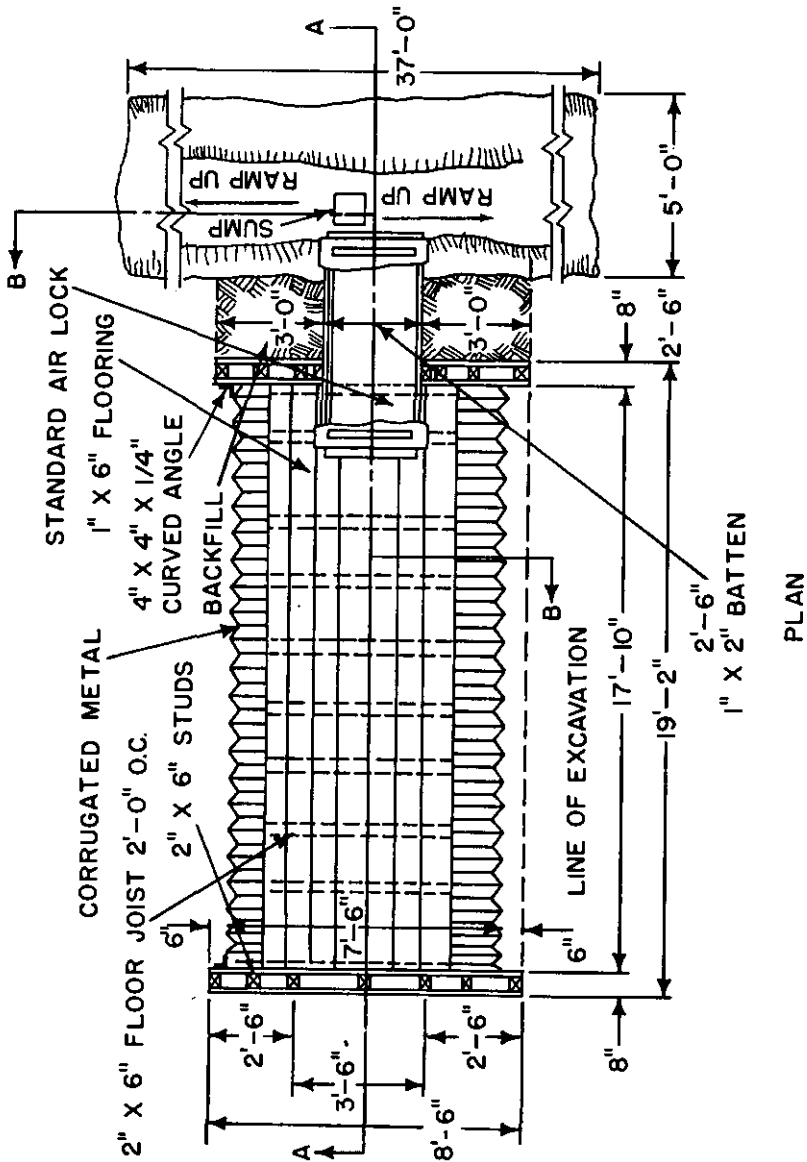
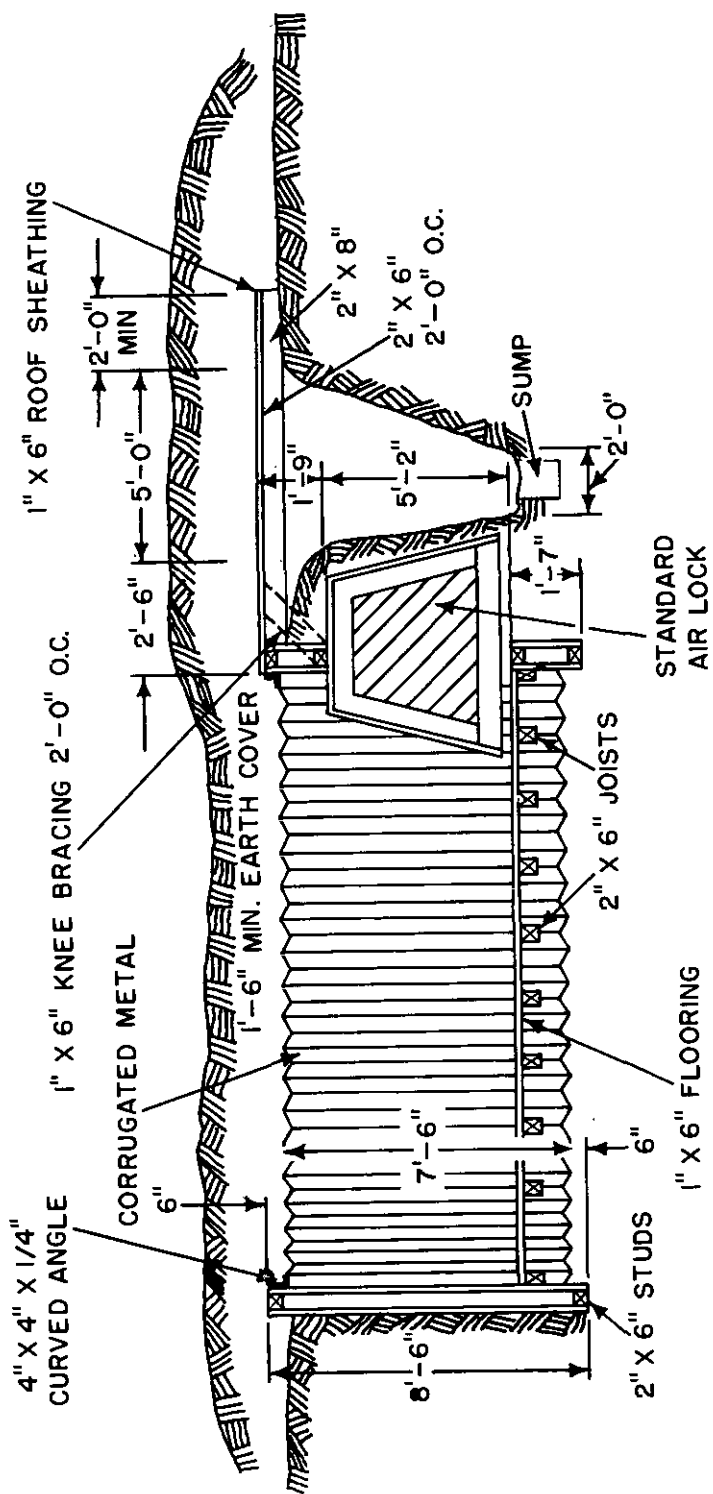
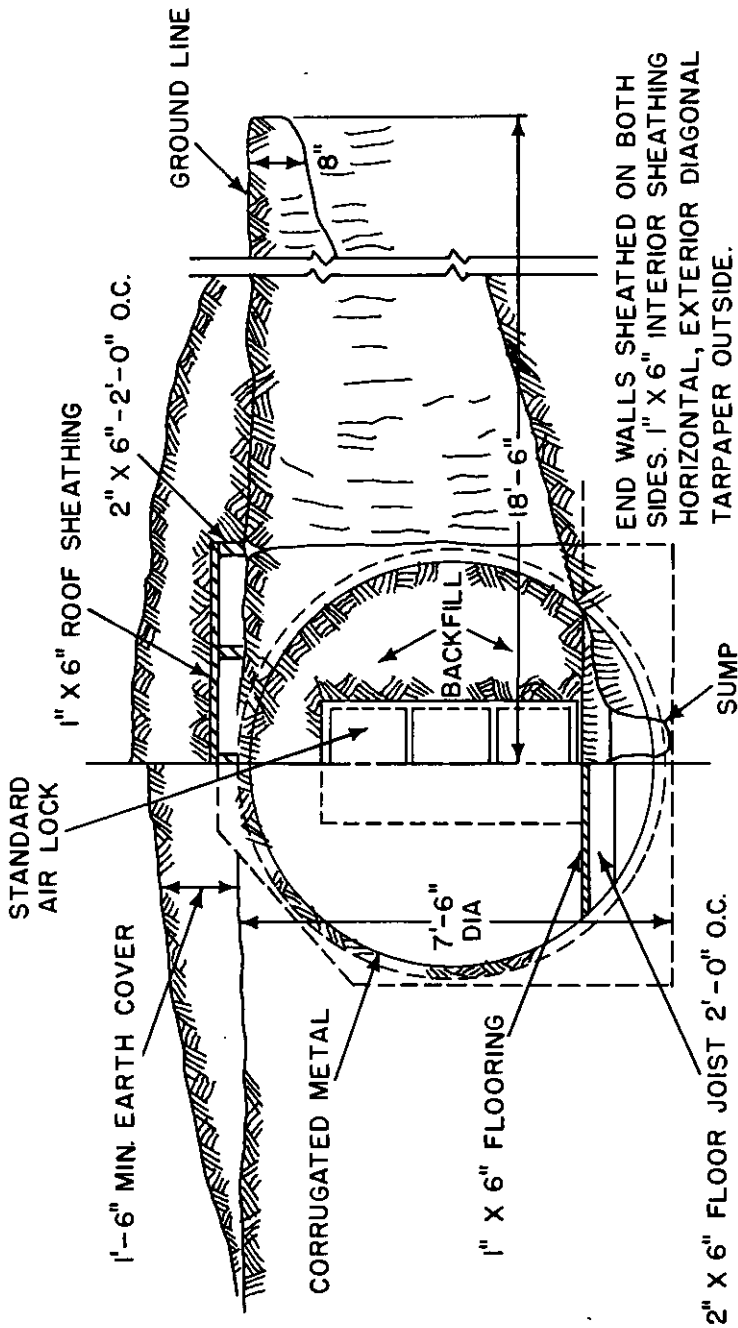

Figure 49. Cut and cover corrugated metal circular shelter.



SECTION "A-A"



SECTION "B-B"

Figure 49—Continued.

e. Cave. Cave shelters are constructed entirely below the surface by mining methods and have a cover of undisturbed earth. They are the least conspicuous type, afford effective protection before they are completed, and require the least construction material. Their disadvantages include limited observation, congested living conditions, small exits, and difficult drainage and ventilation. Their construction is difficult and time consuming and requires experience in mining methods. Men may be trapped in them if exits are blocked or timbering is crushed by a direct hit from a conventional weapon or by air induced ground shock from a nuclear explosion. The degree of protection afforded by cave shelters depends upon the depth in which the chamber is built.

57. Construction Procedures

a. Timber Shelters. Post-cap-stringer type structures using logs or dimensioned timber may be used to construct surface or cut and cover shelters. Figure 47 shows the basic 6 feet by 8 feet modular shelter developed for such use, and some of the combinations by which the basic structure may be utilized to provide larger shelters. Table XIII contains the bill of materials and construction notes for the 6 feet by 8 feet structure using dimensioned timber. The table also shows the sizes of logs which may be used if dimensioned timber is not available.

b. Metal Shelters. Metal structures may be used for both surface and cut and cover shelters. Figure 45 illustrates a surface shelter made from a circular section of corrugated metal. Figures 48 and 49 illustrate cut and cover shelters made from semicircular and circular corrugated metal respectively.

58. Progressive Development

The progressive development of shelters usually consists of increasing the protection afforded by the originally constructed shelter either by adding overhead cover to an open shelter or increasing the thickness of the overhead cover already in place within the capability of the structure to support it. The addition of gas proof and blast proof entrances and heating, ventilation and lighting facilities as described in chapter 12 may be included in the progressive development of a shelter.

Table XIII. Bill of Materials, Modular Section (6' x 8') Shelter Post, Cap, and Stringer Construction—Dimensioned Timber (fig. 47)

| Material list | | | Quantities | | | | |
|---------------|--------------|-------------------|------------|-------|-------|-----------|-------|
| No. | Nomenclature | Rough size | Roof | Front | Right | Left | Rear |
| 1 | Cap or sill | 6" x 8" x 8'-0" | ----- | ----- | 2 | 2 | ----- |
| 2 | Post | 6" x 6" x 5'-10" | ----- | ----- | 3 | 3 | ----- |
| 3 | Stringer** | 6" x 6" x 6'-0" | 16 | ----- | ----- | ----- | ----- |
| 4 | Spreader | 3" x 6" x 5'-0" | ----- | 2 | ----- | ----- | 1 |
| 5 | Post, door | 3" x 6" x 6'-6" | ----- | ----- | ----- | ----- | 1 |
| 6 | Brace | *3" x 6" x 7'-0" | ----- | ----- | ----- | ----- | 1 |
| 7 | Brace | *3" x 6" x 6'-10" | ----- | ----- | 1 | 2 | ----- |
| 8 | Brace | *3" x 6" x 8'-0" | ----- | 2 | ----- | ----- | ----- |
| 9 | Spreader | 2" x 6" x 3'-3" | ----- | ----- | 3 | ----- | ----- |
| 10 | Spreader | 2" x 6" x 2'-9" | ----- | ----- | ----- | ----- | 2 |
| 11 | Spreader | 2" x 6" x 2'-0" | ----- | ----- | ----- | ----- | 2 |
| 12 | Scab | 3" x 6" x 1'-0" | ----- | ----- | ----- | ----- | ----- |
| 13 | Siding | 3" x RW x 8'-0" | ----- | ----- | ----- | 41 1/3 SF | ----- |
| 14 | Siding | 3" x RW x 6'-0" | ----- | 36 SF | ----- | ----- | ----- |
| 15 | Siding | 3" x RW x 4'-0" | ----- | ----- | 24 SF | ----- | ----- |
| 16 | Siding | 3" x RW x 3'-6" | ----- | ----- | ----- | ----- | 21 SF |
| 17 | Roll roofing | 100 sq ft roll | 6 | ----- | ----- | ----- | ----- |
| 18 | Driftpin | 1/2" x 14" | ----- | ----- | 6 | 6 | ----- |
| 19 | Nails | 100d | 25 lb | ----- | ----- | ----- | ----- |
| 20 | Nails | 60d | ----- | 8 lb | 8 lb | 8 lb | 8 lb |

*Allowance for double cut ends of braces is included in overall length as shown under rough size.

**Laminated wood roof designed in accordance with table I, may be substituted if desired.

| Size of rectangular timber | Size of round timber required to equal (in inches) |
|----------------------------|--|
| 6 x 6 | 7 |
| 6 x 8 | 8 |
| 8 x 8 | 10 |
| 8 x 10 | 11 |
| 10 x 10 | 12 |
| 10 x 12 | 13 |
| 12 x 12 | 14 |

Construction Notes

1. Any combination of the four types of side panels shown may be used in regard to location and number of doors required.
2. In the construction of larger shelters consisting of two or more basic units, the exterior wall panels should be based on the number and position of doorways required. Panels to be coupled in the interior of the shelter, forming a double wall, must be of the same type wall construction and provide doorways. Siding is not required on interior walls.
3. Structure can be built as surface or subsurface emplacement. Type of siding material below ground as revetment is optional.
4. Finished or rough dimensioned timber to be used.
5. Typical overhead cover to be used.

Overall size of basic section (with sheathing)

Length..... 8'-6"
 Width..... 6'-6"
 Height..... 7' 8"

CHAPTER 9

CREW SERVED INFANTRY WEAPONS, COMBAT EQUIPMENT AND MATERIEL

59. General

a. Protection of crew served weapons is provided by emplacements which give some protection to the weapon and its crew while in firing position, and which have an adjacent or nearby shelter to provide protection for the crew when not firing. Normally, these positions start out as open emplacements. As the positions are developed, the emplacements are deepened and provided with half overhead cover if applicable. Next the positions are provided with standard shelters either adjoining the emplacement or close at hand. These provide excellent protection for the crew when not firing, while the crew served weapon is equally well protected by being placed on the bottom of the emplacement itself.

b. Overhead cover which extends over the crew and weapon while firing will increase vulnerability to some weapons effects and increase protection from others (par. 16b(2)(b)). Normally, such overhead cover is not worth the effort required to build and camouflage.

c. Crew shelters immediately adjoining and opening into emplacements provide excellent operational capability with good protection, since the crew is not exposed when moving from shelter to weapon and back again. Since emplacement floors are below ground surface, access to adjoining subsurface shelters is relatively simple.

60. Automatic Rifle Emplacement

a. *Open.* The open emplacement for the automatic rifle is developed from the 1- or 2-man foxhole by adding a circular or semicircular firing table and bipod trench, as shown in figure 50. The gunner takes position in the emplacement and points the weapon at the extreme right flank of the target. Keeping his elbow in place he moves the weapon to the extreme left flank firing position while the assistant gunner marks the track of the bipod. The bipod trench and the firing table are excavated when the situation permits, and an empty tin can is embedded to mark the position of the right elbow so that the ends of the bipod trench act as automatic stops at each flank of the target area.

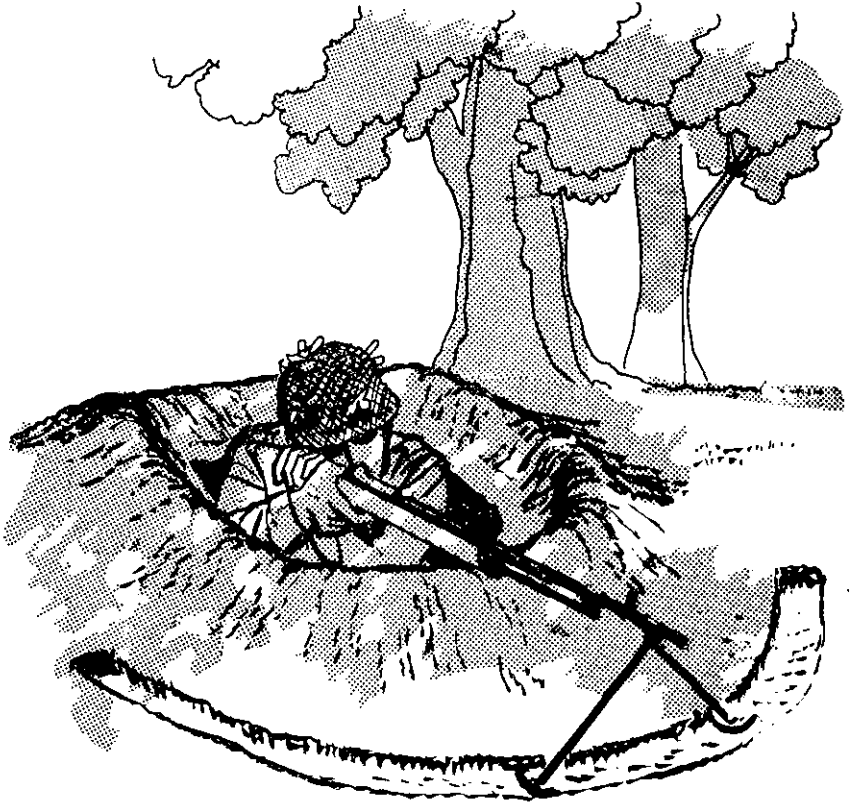

BIPOD TRENCH

Figure 50. Open automatic rifle emplacement.

b. Emplacements With Light Overhead Cover. Limited protection against fragments is provided by overhead cover of the type shown in figure 51. It is constructed as described in paragraph 40.

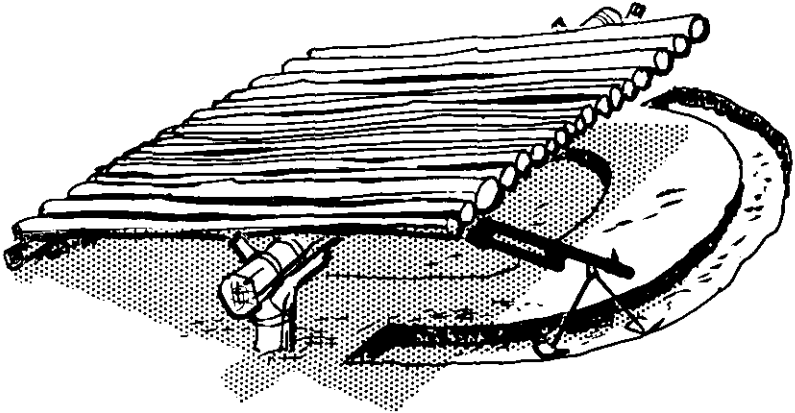

Figure 51. Automatic rifle emplacement with light overhead cover.

c. *Emplacement With Heavy Overhead Cover.* Heavy overhead cover is provided for automatic rifle emplacements by enlarging the excavation to approximately 5 feet 4 inches by 7 feet and framing a post-cap-stringer structure inside it, as shown in figure 52.

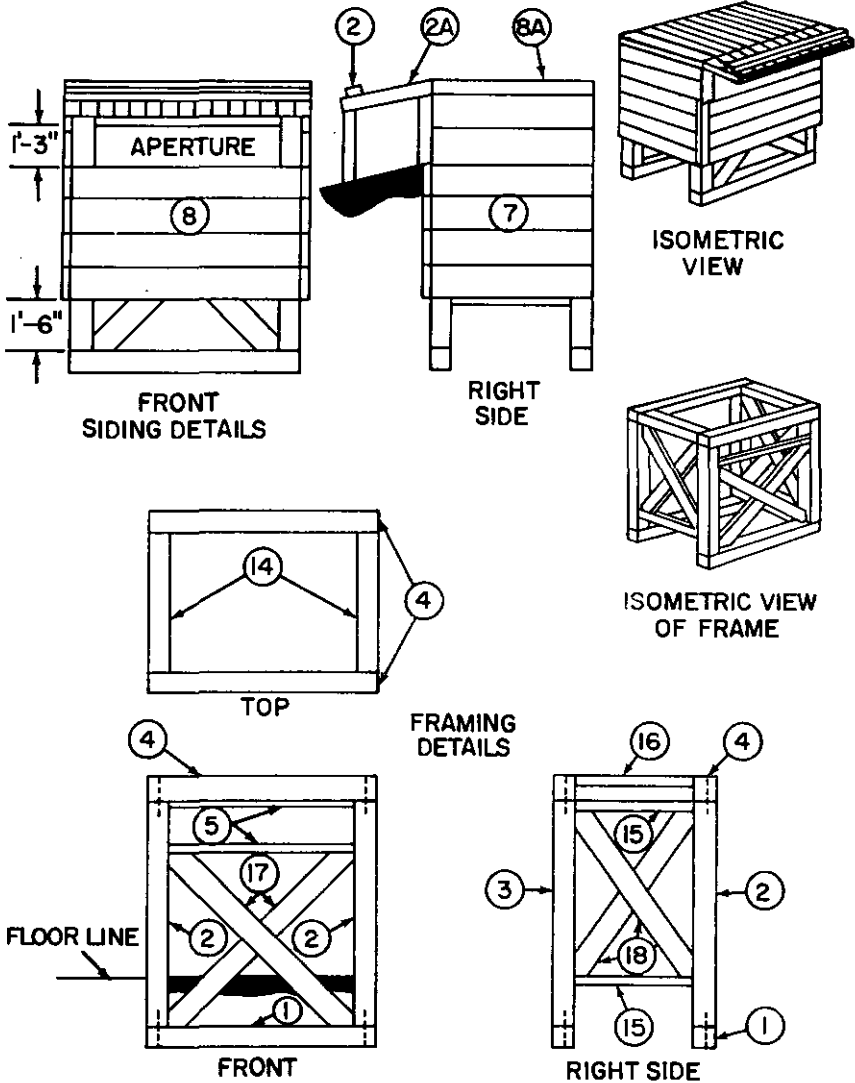

Figure 52. Structure used to support heavy overhead cover for automatic rifle emplacement (five feet by seven feet dimensioned timber, post-cap-stringer).

The bill of materials and construction notes for this structure are shown in table XIV. In the completed emplacement, the firing aperture is the full width of the emplacement. The size of the aperture may be reduced by filling in with sandbags.

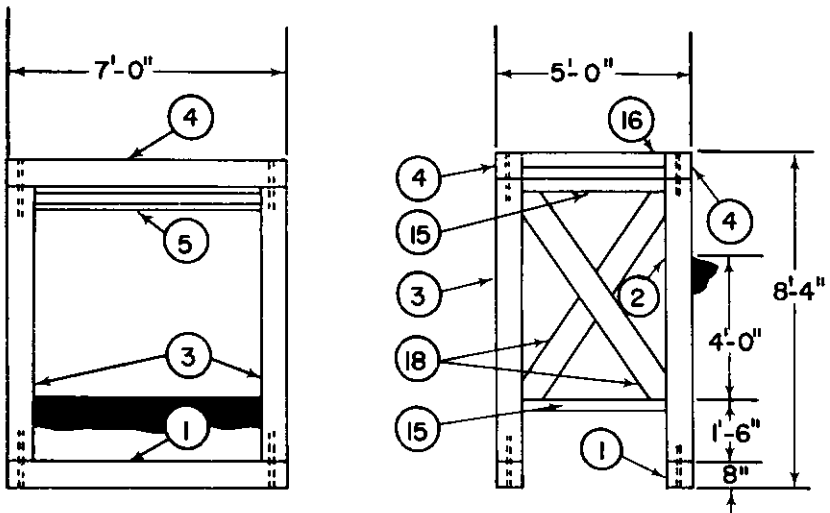
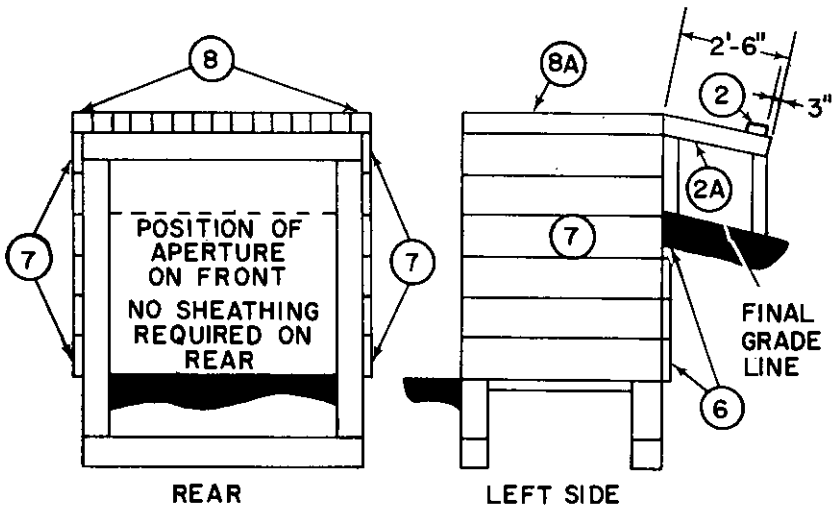

Figure 52—Continued.

61. Caliber .30 Machinegun Emplacements

a. *Open.* There are three types of open emplacements for these weapons; the pit, the horseshoe, and two-foxhole type. Of the three, the two-foxhole type is easier to construct and is less vulnerable to crushing action by tanks.

(1) *Pit type.* In the initial position for the caliber .30 machinegun, the gun is emplaced in a pit as shown in figure 53.

Table XIV. Bill of Materials, AR Emplacement (5 feet by 7 feet), Post-Cap-Stringer—Dimension Timber (fig. 52).

| Material list | | Quantities | | | | |
|---------------------|------------------|------------|-------|------|------|------|
| Nomenclature | Size | Front | Right | Left | Rear | Roof |
| Sill..... | 8" × 8" × 7'-0" | 1 | | | 1 | |
| Post, front..... | 8" × 8" × 7'-0" | 2 | | | | |
| Post, rear..... | 8" × 8" × 7'-0" | | | | 2 | |
| Cap..... | 8" × 8" × 7'-0" | 1 | | | 1 | |
| Spreader..... | 3" × 6" × 5'-8" | 2 | | | 1 | |
| Siding..... | 3" × 12" × 7'-0" | 4 | | | | |
| Siding..... | 3" × 12" × 5'-0" | | 7 | 7 | | |
| Stringer..... | 6" × 6" × 5'-0" | | | | | 15 |
| Apron stringer..... | 6" × 6" × 2'-9" | | | | | 15 |
| Cleat, roof..... | 3" × 6" × 7'-6" | | | | | 1 |
| Driftpin..... | ½" × 12" | 4 | | | 4 | |
| Nails..... | 60d | | | | | |
| Nails..... | 100d | | | | | |
| Sandbags..... | | | | | | |
| Tar paper..... | 35# roll | | | | | |
| Post, apron..... | 8" × 8" × 2'-0" | 4 | | | | |
| Spreader..... | 3" × 8" × 3'-8" | | 2 | 2 | | |
| Brace..... | 3" × 8" × 3'-10" | | 1 | 1 | | |
| Brace..... | 3" × 8" × 7'-9" | 2 | | | | |
| Brace..... | 3" × 8" × 6'-3" | | 2 | 2 | | |

Construction Notes

1. Rough or finished dimension timber to be used.
2. Drill ½" diameter holes for driftpins.
3. Assemble front and rear framing near emplacement site.
4. Manhandle front and rear frames into correct position in the emplacement.
5. Add side spreaders and braces.
6. Add siding to both sides and front.
7. Add stringers and secure with 100d nails.
8. Add apron stringers and secure with 100d nails. Support where necessary according to grade line.
9. Typical overhead cover to be used.
10. When 3" × 12" siding is not available, use 3" × random width.

(2) *Horseshoe type.* The dimensions and layout of the completed emplacement are shown in figure 54. As the first step in its construction, an open pit of the dimensions shown in figure 54 is dug, with the long side of the pit parallel to the line being defended. The spoil is used to form an all around parapet. Then as the second step, a horseshoe shaped trench about two feet wide is dug along the rear and sides of the pit, leaving a chest high shelf in the center to serve as the gun platform, as shown in figure 54. The spoil from this trench is added to the parapet, making it at least three feet thick and low enough to permit all-around fire.

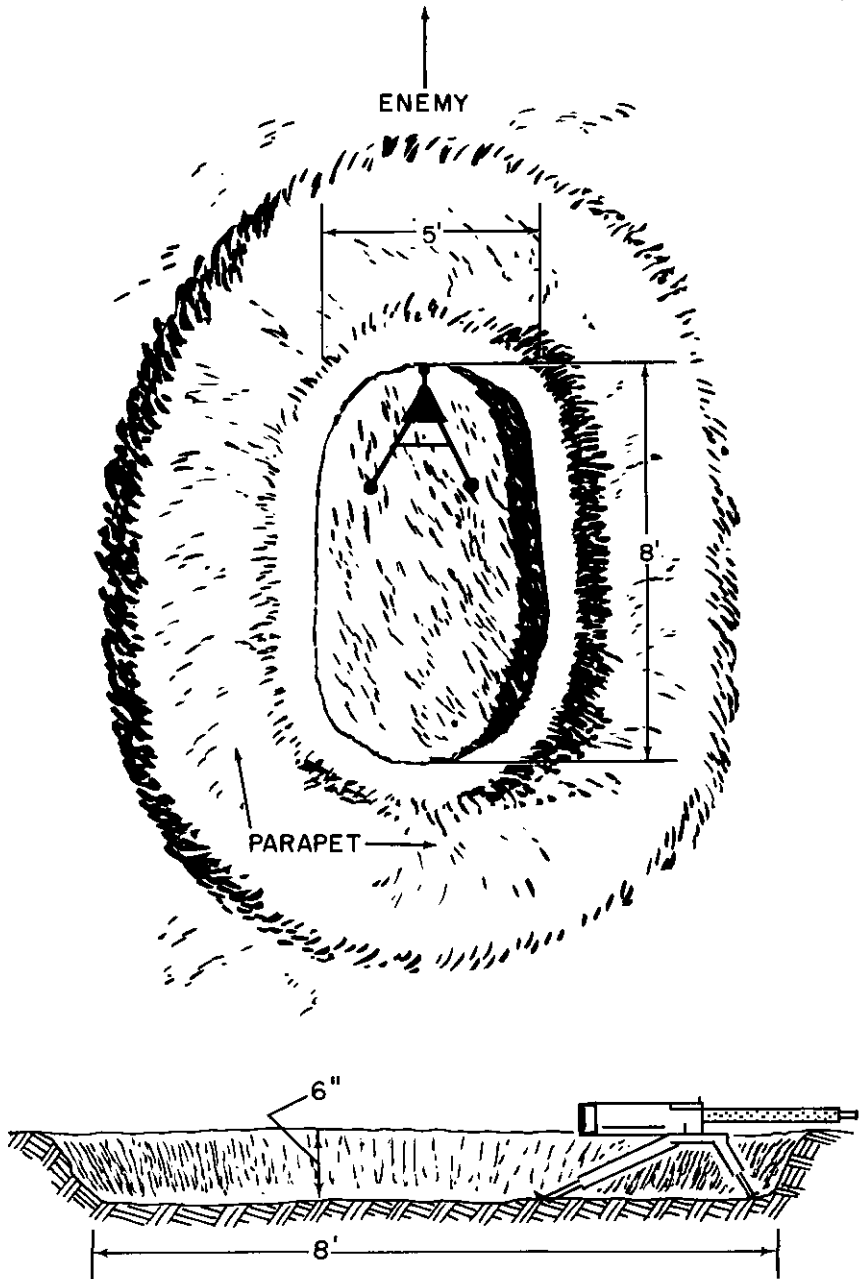

Figure 53. Plan view and cross section of pit type emplacement for caliber .50 machinegun.

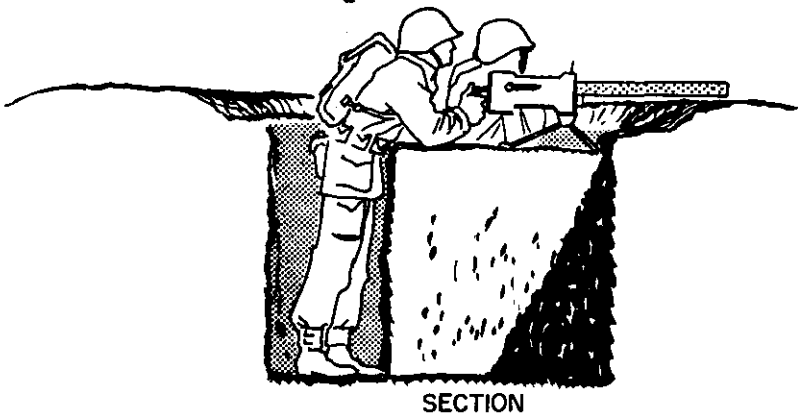
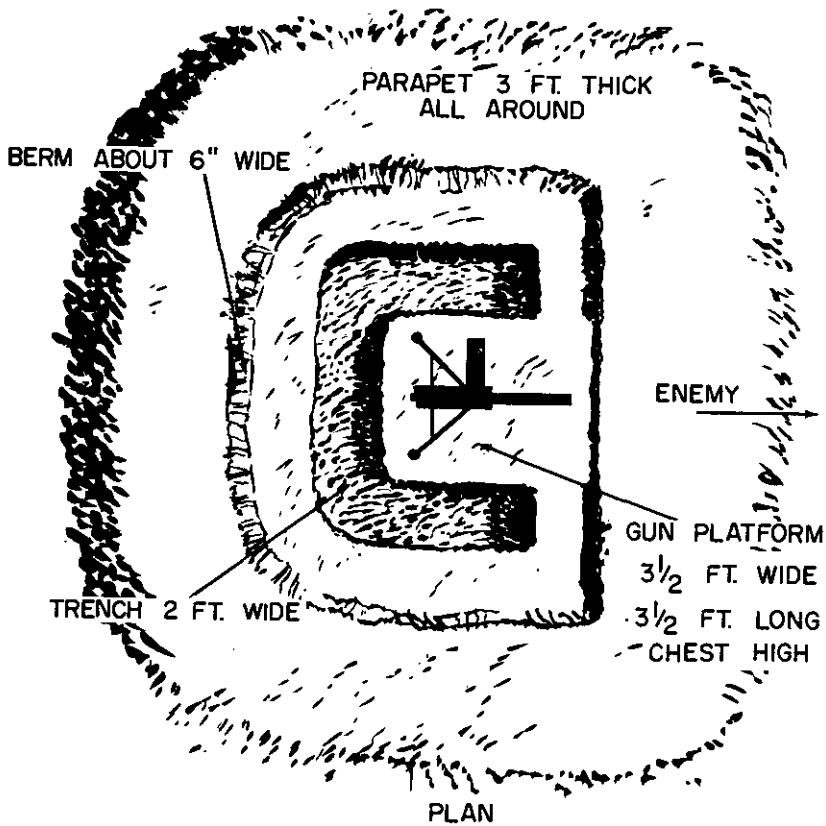

Figure 54. Completed horseshoe type emplacement.

- (3) *Two foxhole type.* This emplacement consists of 2 one-man foxholes close to the gun position, as illustrated in figure 55. The parapet is low enough to permit all around fire.

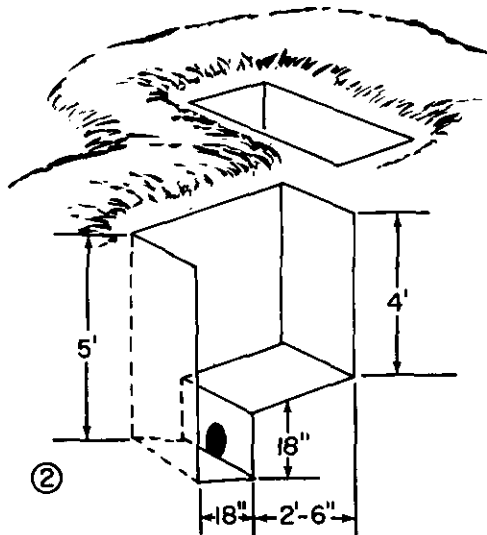
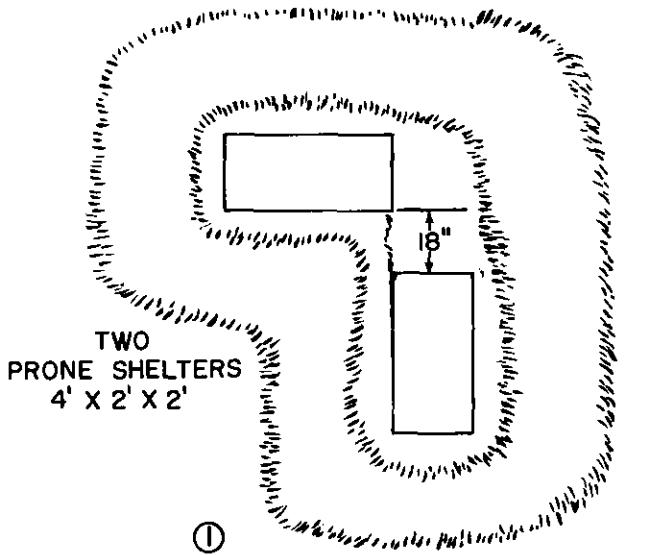

Figure 55. Two foxhole type emplacement.

b. Construction of Overhead Cover.

- (1) *Light overhead cover.* Support for light cover is constructed as described in paragraph 40. For all around fire a level roof is carried above the parapet.

platform is enlarged to 5 feet by 5 feet to accommodate the caliber .50 machinegun mount. The method of constructing this emplacement is similar to that used to construct the horse-shoe emplacement for the machinegun as described in paragraph 61a(2).

- (2) The dimensions and layout when the weapon is used with the M63 anti-aircraft mount are as shown in figure 56.

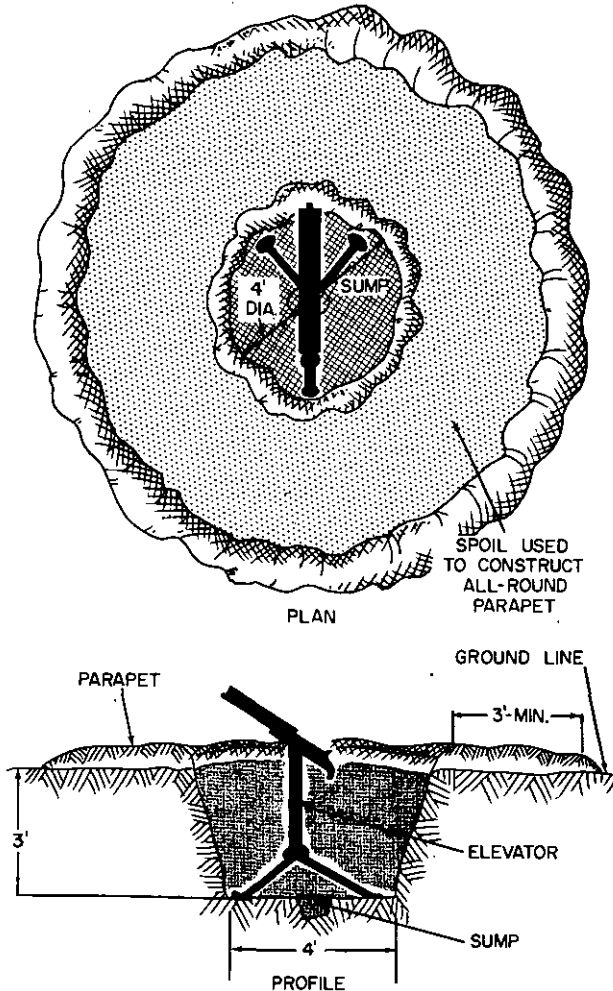

Figure 56. Open emplacement for caliber .50 machinegun using M63 anti-aircraft mount.

b. *Covered Emplacements.* The methods used to provide light and heavy overhead cover for this weapon are generally the same as those described for the machinegun in paragraph 61b. To provide overhead cover for the weapon on its ground mount, the excavation is en-

larged to accommodate a 7-foot by 7-foot post-cap-stringer of the types illustrated in figures 57 and 58 and for which bills of materials and construction notes are provided in tables XV and XVI. The aperture is enlarged and the front leg of the tripod placed outside the aperture. Also, the structure is provided with an apron over the

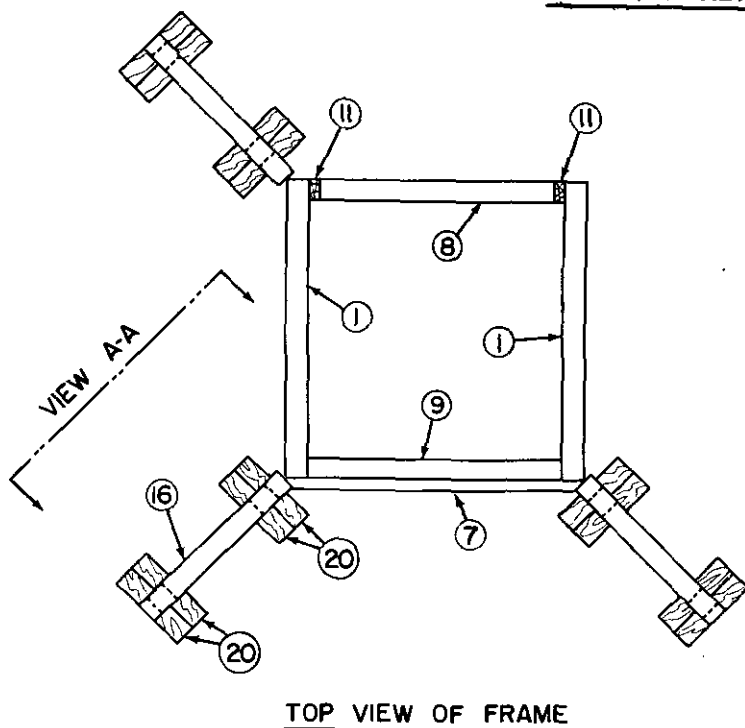
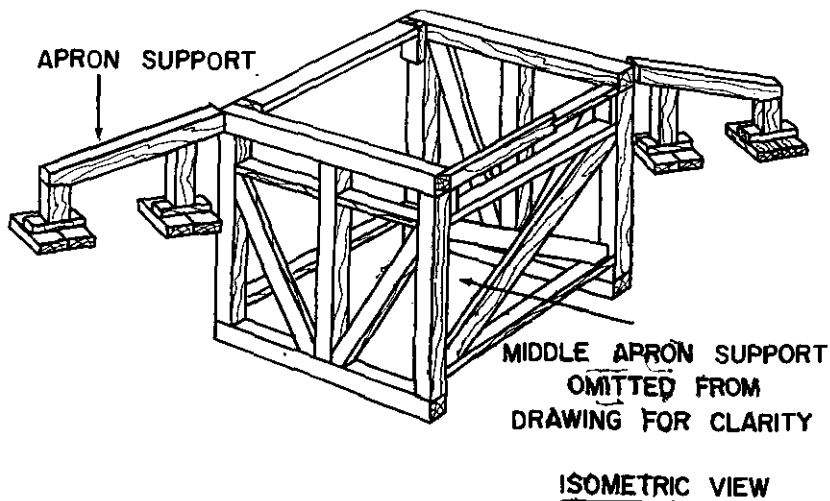

Figure 57. .50 caliber machinegun emplacement, 7-foot by 7-foot post-cap-stringer, dimension timber.

aperture to protect the projecting parts of the weapon. When the weapon is to be employed primarily against aircraft, overhead cover is not practical for the emplacement. However, foxholes with overhead cover may be constructed near by or may be connected to the emplacement to provide protection for the crew.

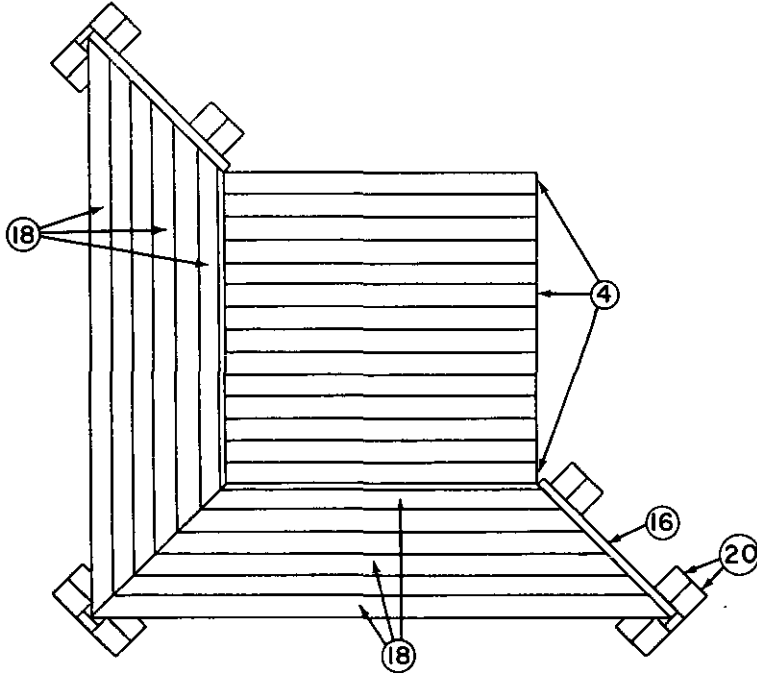
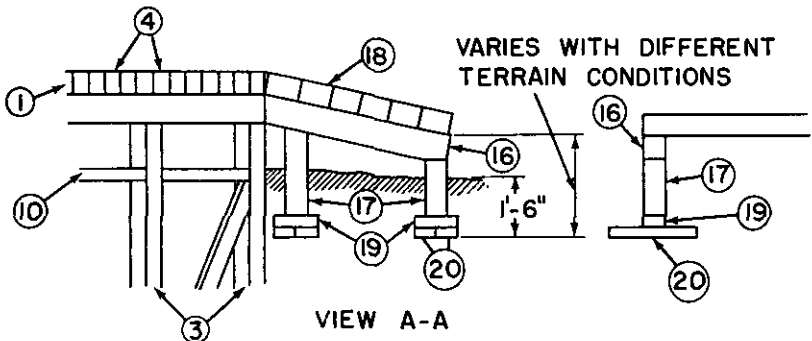

Figure 57—Continued.

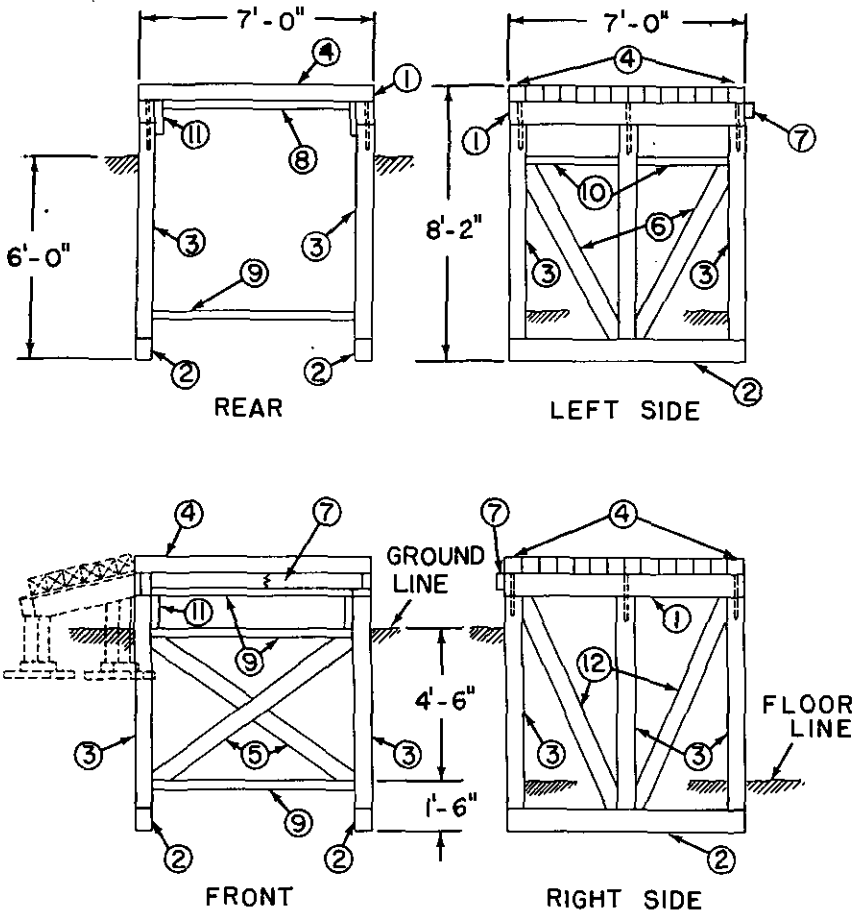
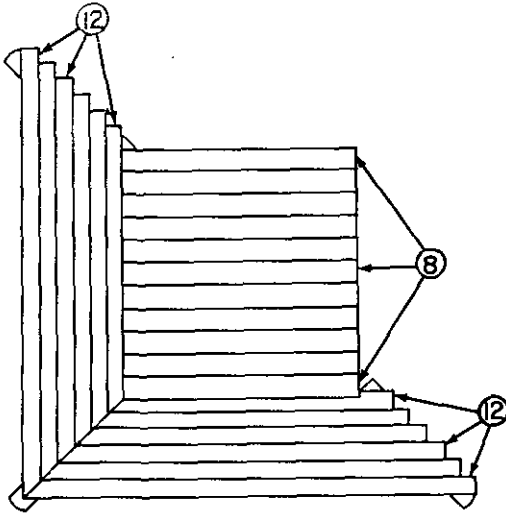
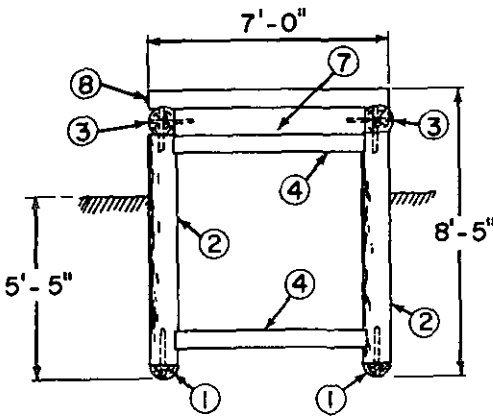

Figure 57—Continued.



TOP VIEW SHOWING STRINGERS



REAR

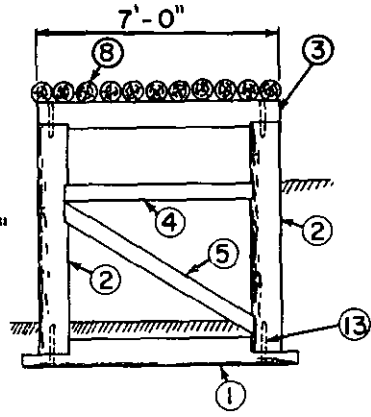

LEFT SIDE

Figure 58—Continued.

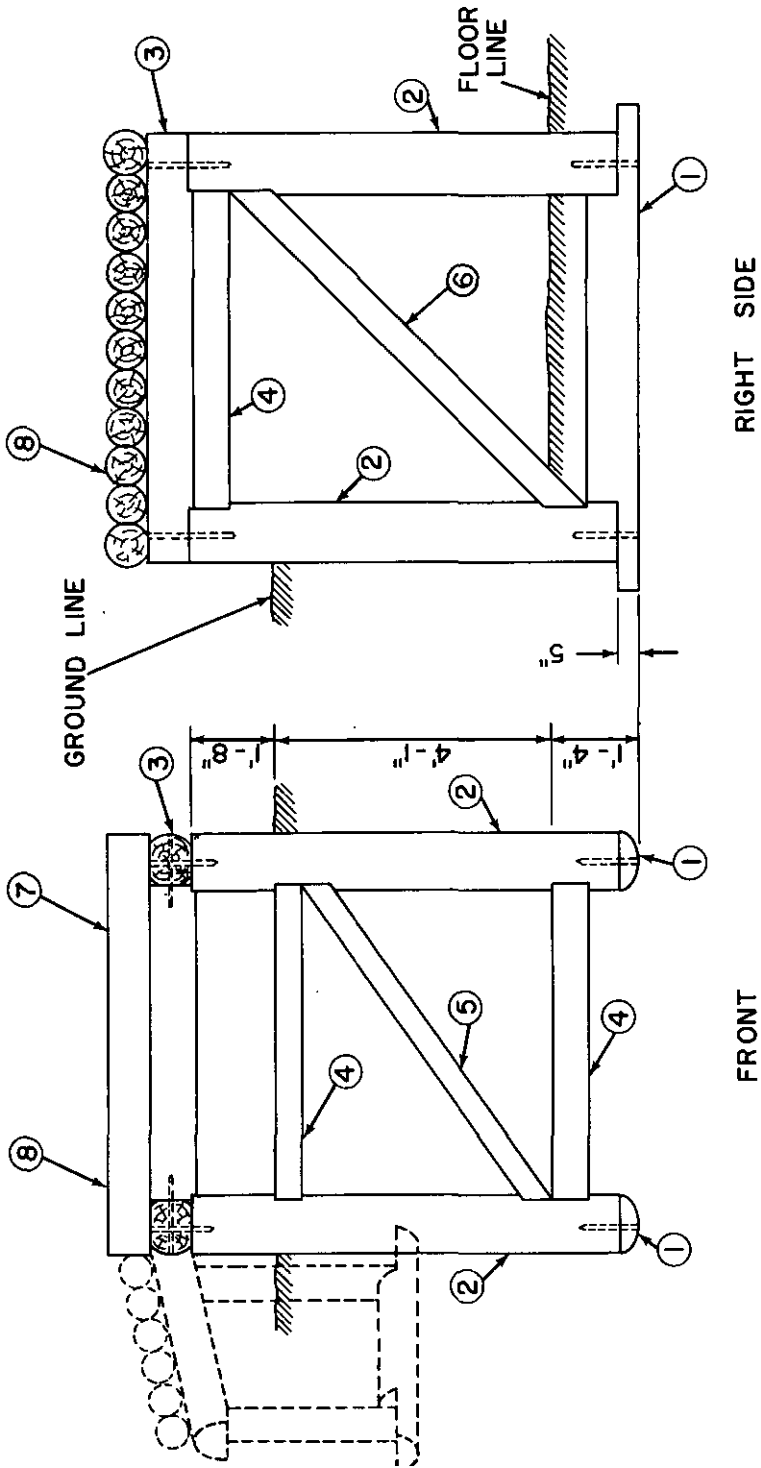

Figure 58—Continued.

63. Emplacements For 3.5-Inch Rocket Launcher

a. *Open Positions.* The two types of open emplacements for the 3.5-inch rocket launcher are the pit type, and the horseshoe type.

(1) *Pit type.* This emplacement (fig. 59) consists of a circular pit with concentric circular pit excavated below the surface.

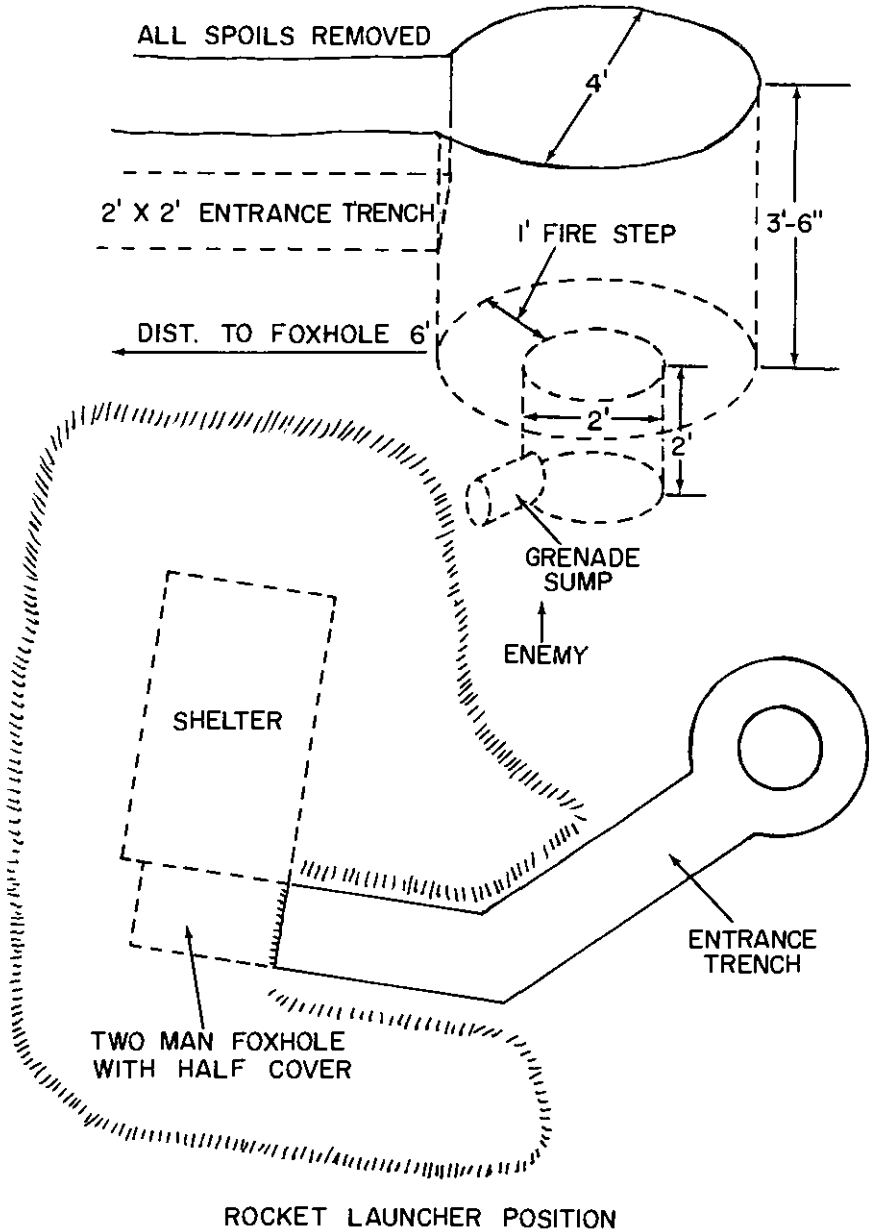

Figure 59. Pit type emplacement for 3.5-inch rocket launcher.

The pit is used for shoulder firing from a position on the fire step. If tanks overrun the position the gunner crouches in the lower pit and the assistant takes cover in his own foxhole.

Table XV. *Bill of Materials, .50 caliber Machinegun Emplacement (7 feet by 7 feet) Post-Cap-Stringer Construction Dimension Timber (fig. 57)*

| No. | Nomenclature | Rough size | Quantity |
|-----|----------------|-----------------|----------|
| 1 | Cap..... | 6"×8"×7'-0" | 2 |
| 2 | Sill..... | 6"×8"×7'-0" | 2 |
| 3 | Post..... | 6"×6"×6'-4" | 6 |
| 4 | Stringer..... | 6"×6"×7'-0" | 14 |
| 5 | Brace..... | 3"×6"×7'-0" | 2 |
| 6 | Brace..... | 3"×6"×6'-0" | 2 |
| 7 | Filler..... | 3"×6"×7'-0" | 1 |
| 8 | Spreader..... | 3"×6"×5'-6" | 1 |
| 9 | Spreader..... | 3"×6"×6'-0" | 4 |
| 10 | Spreader..... | 3"×6"×2'-9" | 2 |
| 11 | Scab..... | 3"×6"×1'-0" | 4 |
| 12 | Brace..... | 3"×6"×7'-0" | 2 |
| 13 | Nails..... | 100d | 20 lb |
| 14 | Nails..... | 60d | 15 lb |
| 15 | Tar paper..... | 100-ft. roll | 3 rolls |
| 16 | Apron cap..... | 6"×8"×4'-3" | 3 |
| 17 | Post..... | 6"×6"×3'-0"* | 6 |
| 18 | Stringer..... | 6"×6"×7' to 13' | 12 |
| 19 | Footer..... | 3"×6"×1'-0" | 6 |
| 20 | Footer..... | 3"×6"×2'-0" | 12 |
| 21 | Driftpin..... | ½"×16" | 6 |

*Actual post length varies with terrain conditions; 3'-0" is long enough for any site.

Construction Notes

Body

1. Place sills 2 in parallel trenches in floor of emplacement.
2. Nail posts 3 to sills 2.
3. Drill driftpin holes in cap 1 and secure cap to posts.
4. Add scab 11 and spreaders 8, 9.
5. Complete framing by adding braces 5, 6, 12 and spreaders 10.
6. Nail stringers 4 to cap 1.

Apron

1. Position footers level in hole.
2. Nail posts 17 to footers 19, 20.
3. Nail apron cap 16 to cap 1 and posts 17.
4. Nail stringers 18 to cap 16.
5. Typical overhead cover to be used.

Table XVI. *Bill of Materials, .50 caliber Machinegun Emplacement (7 feet by 7 feet) Post-Cap-Stringer Construction—Round Timber (fig. 58)*

| Material list | | | |
|---------------|---------------------|--------------|----------|
| No. | Nomenclature | Size | Quantity |
| 1 | Sill..... | 10"×8'-0" | 2 |
| 2 | Post..... | 10"×6'-8" | 4 |
| 3 | Cap..... | 10"×7'-0" | 2 |
| 4 | Spreader..... | 6"×5'-6" | 6 |
| 5 | Brace..... | 6"×6'-10" | 2 |
| 6 | Brace..... | 6"×8'-10" | 1 |
| 7 | Spreader..... | 10"×5'-6" | 2 |
| 8 | Stringer..... | 8"×7'-0" | 11 |
| 9 | Apron sill..... | 10"×5'-0" | 3 |
| 10 | Apron post..... | 8"×4'-0"* | 6 |
| 11 | Apron cap..... | 8"×4'-8" | 3 |
| 12 | Apron stringer..... | 6"×8" to 13' | 12 |
| 13 | Driftpin..... | ½"×16" | 24 |
| 14 | Nails..... | 100d | ----- |
| 15 | Nails..... | 60d | ----- |
| 16 | Tar paper..... | 100 ft roll | 3 rolls |

*Actual post length varies with terrain conditions; 4'-0" is long enough for most sites.

Construction Notes

1. Assemble right and left framing near emplacement site (parts 1, 2, 3, 4, 5, 6).
2. Manhandle right and left side frames into correct position in the emplacement.
3. Complete framing by adding spreaders (parts 4 and 7 and brace (part 5)).
4. Assemble apron supports (parts 9, 10, 11 near emplacement site).
5. Manhandle apron supports into correct position in the emplacement.
6. Add stringers (parts 8 and 12).
7. Drill ¼" diameter holes for driftpins.
8. Flatten logs where nailing surface is required (notch approximately 1" deep).
9. Typical overhead cover to be used.

b. Emplacement With Light Overhead Cover. The two-foxhole emplacement shown in figure 60 provides light overhead cover for the crew, except when actually firing. The overhead cover is supported as described in paragraph 40. The gunner occupies the hole on the left; the assistant the hole on the right. If the position is in danger of being overrun by tanks the weapon may be taken into the foxhole.

c. Emplacement With Heavy Overhead Cover. Providing heavy overhead cover for a rocket launcher is impracticable because heat, concussion, and other effects of the black blast prevent firing it from a confined space. If such protection is desired when the weapon is not being fired a small personnel shelter with heavy overhead cover may adjoin the weapon emplacement.

64. Emplacements For Rifle, 106-MM

The 106-mm rifle is usually mounted on a ¼-ton truck and is treated as a self-propelled weapon, so far as emplacements are concerned.

Since the weapon must be kept mobile because its characteristic black-blast reveals its position and requires it to be moved after a few rounds, its normal employment is as a roving weapon, firing a few rounds from one position then moving to another. In a defensive operation several open pits should be constructed with concealed routes from these firing positions to a concealed shelter position with overhead cover. The weapon remains in the shelter until needed, then, after firing, it is moved to another firing position or back to its shelter. The firing pit should protect the sides and front of the body of the vehicle with the rifle about parapet level. The rear should be ramped so the vehicle can displace rapidly. The covering shelter is constructed using standard shelter designs. Figure 61 illustrates a typical firing position for the recoilless rifle.

65. Emplacements For 81-MM Mortar, M29

The emplacements illustrated in figure 62, are circular in shape with the sides of the emplacement sloping inward toward the bottom. The floor slopes to the drainage sump which is located under the open gap

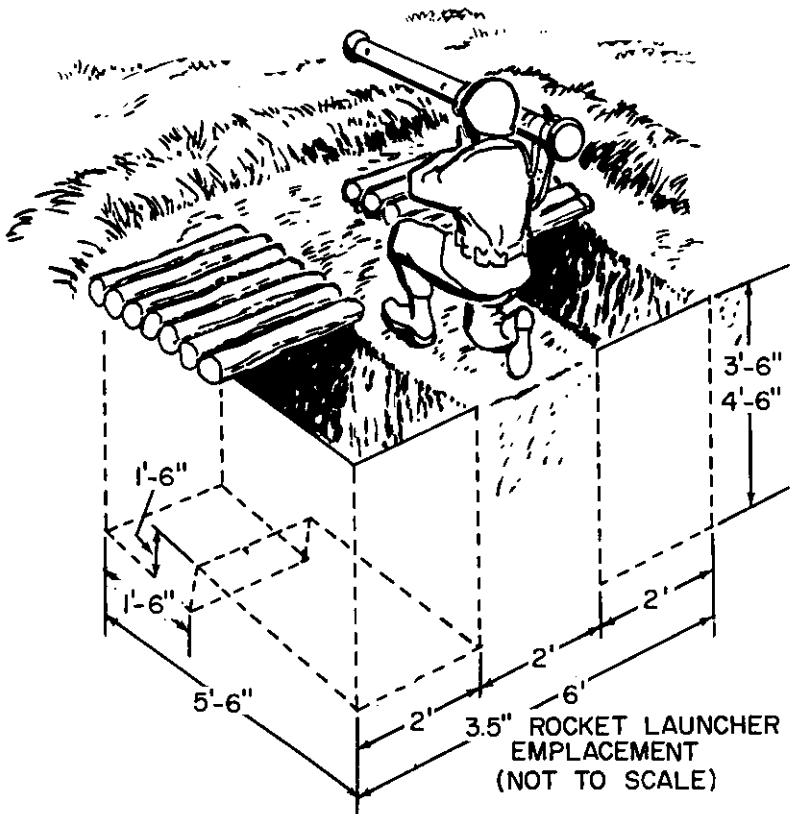
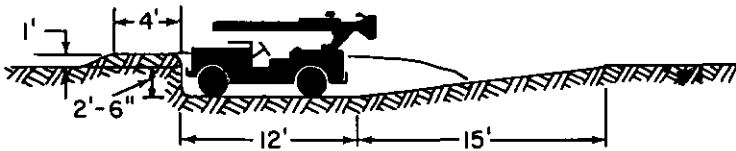
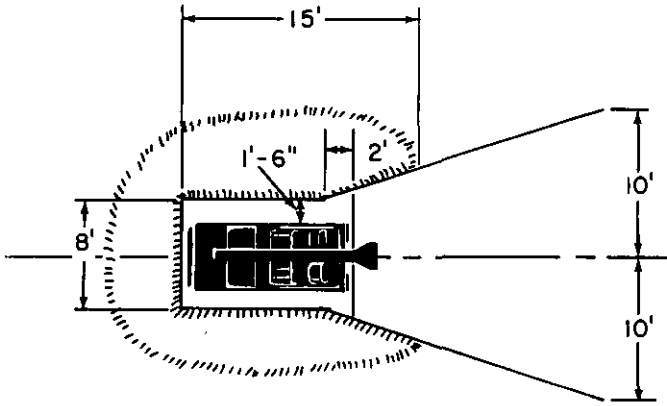

Figure 60. Two-foxhole emplacements for 3.5-inch rocket launcher with light overhead cover.



106 MM RECOILLESS RIFLE POSITION
JEEP MOUNTED

① MOUNTED ON $\frac{1}{4}$ TON TRUCK

Figure 61. Emplacement for 106-mm rifle.

in the parapet. An ammunition ready rack or niche, located so that it is convenient for the gunner, is built into the side of the emplacement. The bottom of the ammunition rack is elevated from the floor of the emplacement. Another ready rack may be constructed in one side of the trench leading to the position. The initial emplacement is revetted using sandbags and the improved emplacement is revetted using corrugated metal. Before constructing the parapet, the mortar is laid for direction of fire by the use of an aiming circle or alternate means. Aiming stakes are then normally placed out at a referred deflection of 2,800 mils. The parapet is then constructed, leaving a 3-foot gap for the line of sight. This imaginary line of sight should be so positioned that it is 1 foot from the right edge of the gap. This will

allow an approximate 1,500-mil sector of fire without moving any portion of the parapet. The parapet should be not more than 20 inches high and a minimum of 36 inches wide. Dirt should not be placed within 1½ feet of the edges of the sighting gap; in order that sandbags positioned here may be removed to provide a greater sector of fire when necessary. An exit trench may be constructed leading to personnel shelters and to other mortar positions.

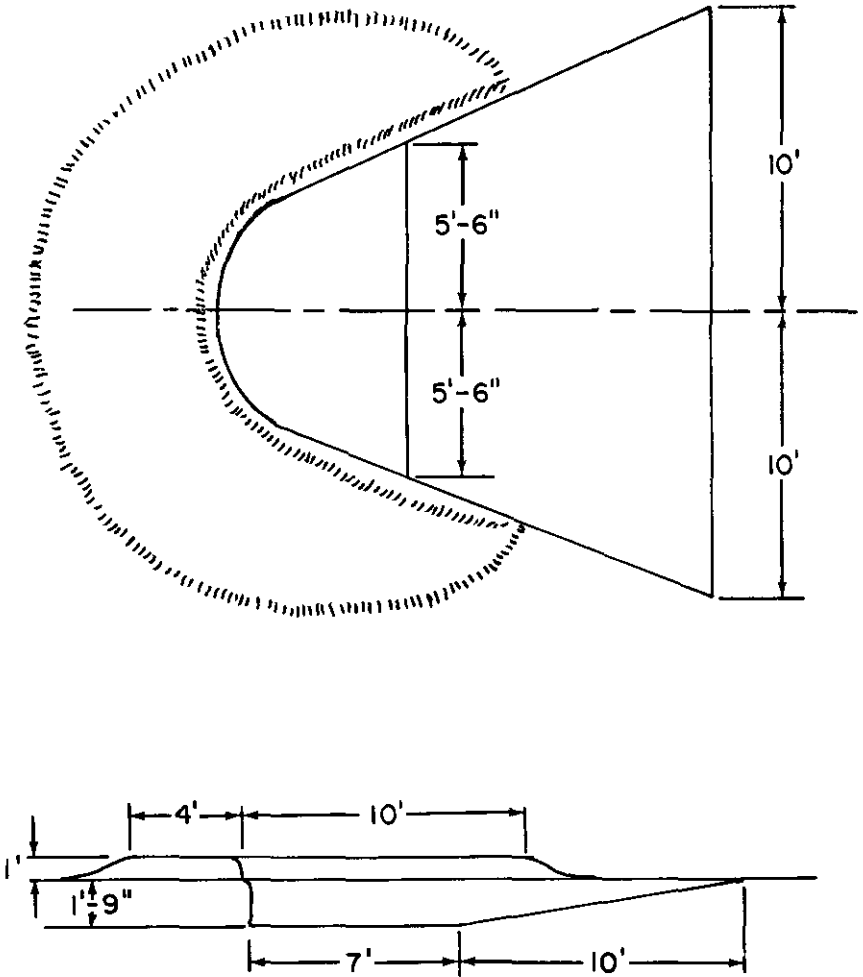

106 MM RECOILLESS RIFLE POSITION
GROUND MOUNTED

② ON GROUND MOUNT

Figure 61—Continued.

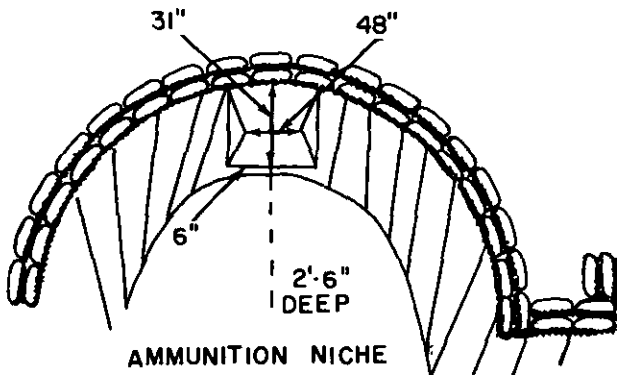
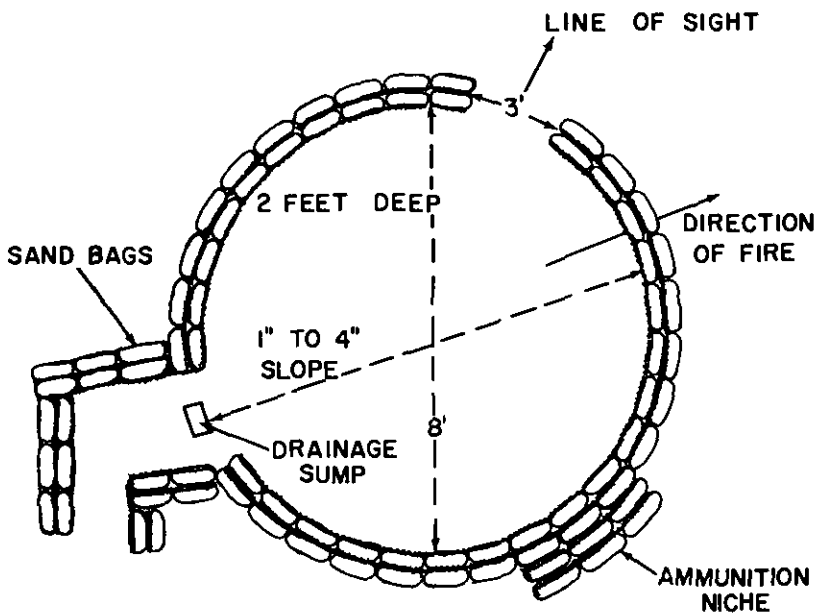

① INITIAL EMPLACEMENTS

Figure 62. Emplacement for 81-mm mortar.

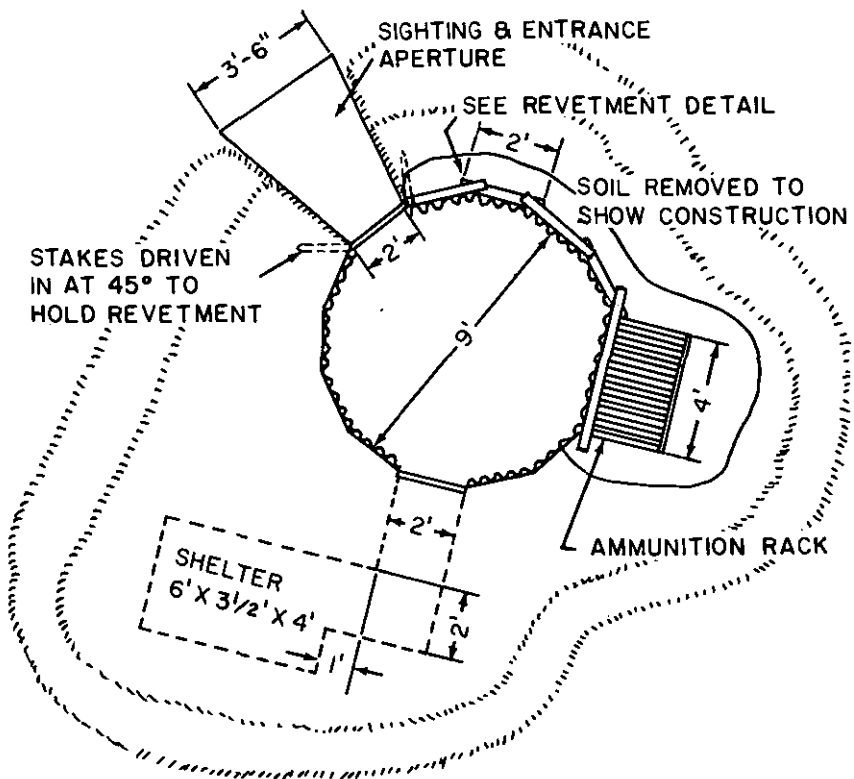

② IMPROVED EMPLACEMENTS

Figure 62—Continued.

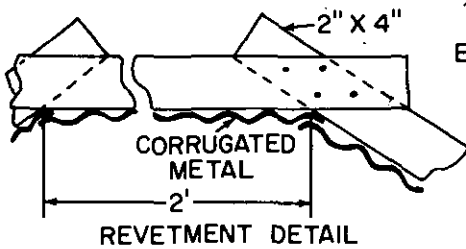
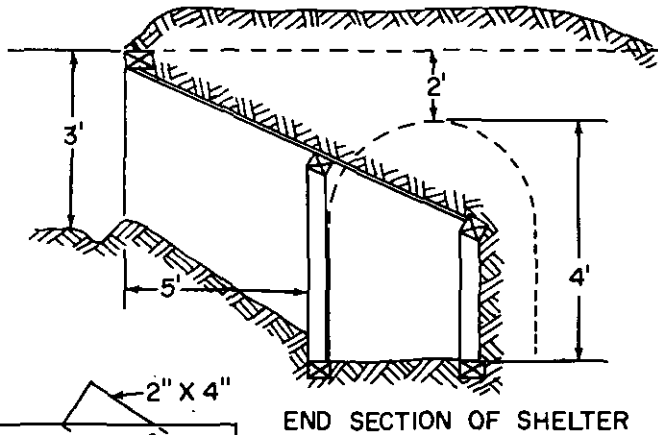
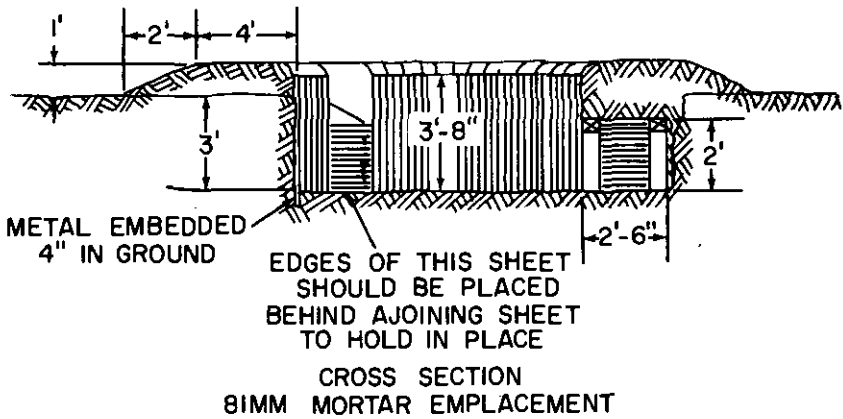

② IMPROVED IMPLACEMENTS

Figure 62--Continued.

Table XVII. Characteristics of Crew Served Infantry and Artillery Weapons Emplacements

| Type of emplacement or shelter | Nuclear weapons effects ¹ | | | Conventional weapons effects ² | | | Protection afforded ¹ | | Total construction time in man hours for construction with D-handle shovels and ordinary carpentry tools ³ | | Weight and volume of materials | | | | |
|--|--|-----------------------|----------------|---|-----------------|------------------|----------------------------------|------------------------------------|---|-----------------------------|--|---------------------------|--|---------------------------|--------------------|
| | Nuclear radiation transmission factors | Initial neutron gamma | Residual gamma | Fortification protection factor | Thermal effects | Tracked vehicles | Artillery fragments | Revetment materials for cover only | Complete revetment | No revetment materials used | Corrugated metal construction ⁴ | Straw lumber construction | Corrugated metal construction ⁴ | Straw lumber construction | Complete revetment |
| Open automatic rifle emplacement with 18" of cover. | 0.1 | 0.3 | 0.1 | 65 | Very good | Good | Fair | N/A | 4.0 | N/A | 45 | N/A | 170 | 3.0 | 200 |
| Open horseshoe type .30 cal machinegun emplacement. | 0.07 | 0.2 | 0.02 | 55 | Very good | Virtually none | Good | 4.0 | N/A | 7.0 | N/A | 0.5 | 70 | 4.0 | 270 |
| Open 2 one-man forhole type light machinegun emplacement. | 0.15 | 0.4 | 0.1 | 70 | Good | Fair | Fair to good | N/A | 2.0 | 7.0 | N/A | N/A | N/A | 5.0 | 450 |
| Open 2 one-man forhole type light machinegun emplacement. | 0.1 | 0.3 | 0.1 | 65 | Very good | Good | Good | N/A | 4.0 | 7.0 | N/A | N/A | 530 | 10.0 | 640 |
| Horseshoe type light machinegun emplacement with full cover. | 0.06 | 0.2 | 0.003 | 55 | Very good | Fair | Very good | 9.0 | N/A | 14.0 | 190 | 4.0 | 250 | 13.0 | 800 |
| 2 one-man forhole type 1 $\frac{1}{2}$ machinegun type emplacement with $\frac{1}{4}$ cover and adjoining shelter. | 0.015 | 0.03 | 0.0005 | 30 | Excellent | Good | Excellent | 15.0 | N/A | 28.0 | 250 | 2.5 | 630 | 7.5 | 850 |
| Chenau type .50 cal machinegun emplacement. | 0.3 | 0.5 | 0.15 | 80 | Fair | Fair | Fair | N/A | 10.0 | 16.5 | N/A | N/A | 300 | 5.0 | 430 |
| Pit type emplacement for 3.5 rocket launcher. | 0.3 | 0.5 | 0.15 | 80 | Fair | Fair | Fair | N/A | 3.0 | 6.0 | N/A | N/A | 110 | 1.0 | 160 |
| 81-mm mortar emplacement. | 0.4 | 0.7 | 0.3 | 85 | Good | Virtually none | Fair | N/A | N/A | 13.0 | N/A | N/A | 210 | 3.0 | N/A |
| 4.2-inch mortar emplacement. | 0.4 | 0.7 | 0.3 | 85 | Good | Virtually none | Fair | N/A | N/A | 29.0 | N/A | N/A | 370 | 6.0 | N/A |
| Recoilless rifle position (mounted). | 0.4 | 0.6 | 0.2 | 80 | Fair | Virtually none | Fair | N/A | 30.0 | N/A | N/A | N/A | N/A | N/A | N/A |
| Recoilless rifle position (dismounted). | 0.5 | 0.7 | 0.2 | 85 | Fair | Virtually none | Fair | N/A | 17.0 | N/A | N/A | N/A | N/A | N/A | N/A |

CHARACTERISTICS OF ARTILLERY WEAPONS EMPACEMENTS

¹ Protection afforded assumes the occupants of fortifications are in the most protected position of their fortifications. For most fortifications protection decreases as the angle of sight from the position to the center of the weapon burst increases.
² For blast effects, see paragraph 16.
³ For direct fire weapons effects, see paragraph 9.
⁴ For close combat weapons effects, see paragraph 7.
⁵ Assumes normal digging capability in daylight with trained troops.
⁶ Assumes fallout is kept out of hole at surface level by some sort of cover.
⁷ May include wooden framing and braces.

Note. Classification of Fortifications by Attenuating of Residual Radiation.
 a. Fortifications may be generally classified according to their attenuation of residual radiation. Such classification is shown below:
 Fallout Attenuation Classifications
 Transmission factors Classification General guidance in high level radiation field
 Less than 0.001 Excellent Remain in place.
 0.001 to 0.005 Good Probably remain in place.
 0.005 to 0.01 Fair Probably leave position at optimum time.
 More than 0.01 Poor Leave position at optimum time.

b. A general idea of the dose to be expected with the classifications shown above is tabulated below, using a fallout arrival time of H+1 and a stay time of 96 hours. Under these conditions the total incident dose in rem is exactly three times the dose rate of H+1. Assuming an H+1 dose of 5,000 rem/hour:
 Interior Dose for Various Fallout Classifications*
 Classification Total Dose
 Excellent Less than 15 rem*
 Good 15 to 75 rem*
 Fair 75 to 150 rem*
 Poor More than 150 rem*
 *See conditions in appendix II on fortification protection factor.

66. Emplacement For 4.2-Inch Mortar, M30

Construction of the 4.2-inch mortar emplacement is identical to that of the 81-mm mortar emplacement except for changes in dimensions as indicated in figure 63.

67. Protection Afforded

A tabulation of the protection afforded by each emplacement is included in table XVII.

68. Progressive Development

Crew served infantry weapons emplacements are progressively developed as shown in *a* through *c* below.

a. Open Positions. The initial stage of the development of an emplacement, when under fire or threat of immediate attack, is the excavation of an open shallow pit.

b. Positions With Light Overhead Cover. This stage begins with deepening and revetting pits for gunners. Along with the revetment, supports are installed for such overhead cover as is included in the eventual plan. The overhead cover actually constructed during this stage should be the appropriate portion of the heavy overhead cover as described in paragraphs 36 through 40.

c. Positions With Heavy Overhead Cover. When intended for eventual heavy cover, squared timber (or round log posts) and plank sheathing are installed during the revetting operation. Timber or log structures are installed when practicable, using post-cap method of construction, with either stringer or laminated roofs, to receive the overhead cover.

69. Shelters

Shelters are not used to provide protection for crew served infantry weapons while firing. Shelters may be constructed nearby or adjoining for use by the crew when the weapon is not being fired.

70. Combat Equipment

Radios, switchboards and other combat equipment are usually protected if the user or wearer of the equipment is protected. Photographic film and certain transistor powered communications equipment may be adversely affected by levels of radiation below that which will cause personnel casualties. The instruction manual on these items should be consulted to determine any special protection required.

71. Combat Materiel

Protection for POL, rations, ammunition, and other combat materiel may be provided by the use of standard shelters or trenches.

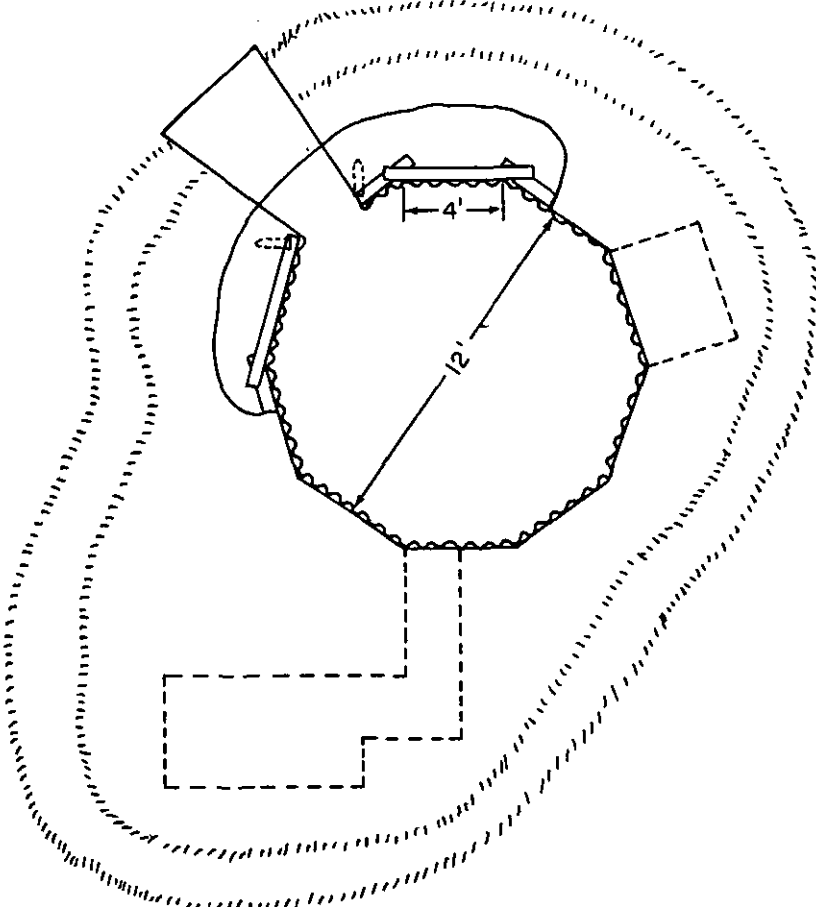
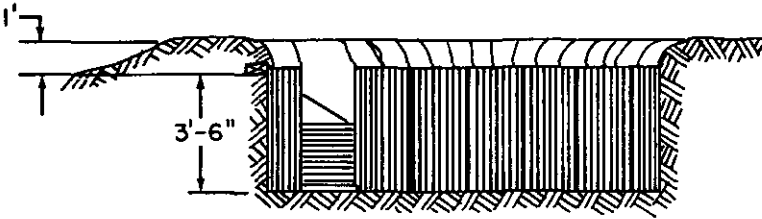

ALL DIMENSIONS AND REMARKS ARE THE SAME AS THOSE ON THE 81MM MORTAR EMPLACEMENT EXCEPT THOSE NOTED.

Figure 63. Emplacement for 4.2-inch mortar.

CHAPTER 10

ARTILLERY WEAPONS

72. General

Protection for artillery weapons is provided by emplacements which permit maximum flexibility in the delivery of fire, and at the same time protect the weapon and its crew against the effects of conventional and nuclear weapons. The protection afforded by each of the emplacements described below is tabulated in table XVII.

73. 105–155 Howitzer

The emplacement for these weapons consists of a circular pit, of the dimensions and layout shown in figure 64. This figure shows the emplacement in its final stage of development. Paragraph 78 discusses the progressive development of the emplacement to this stage.

74. 8-Inch Howitzer, 155-MM Gun

Emplacements for these weapons are shaped like the sector of a circle, pointing in the direction in which the weapon will fire as shown in figure 65. The direction of fire is determined and marked prior to the construction of the emplacement. If the required sector of fire exceeds that which can be achieved by traversing the weapon, the rear of the emplacement is widened to permit shifting the trails.

75. 280-MM Gun

Pit type emplacements are not used with this weapon. It is usually emplaced at ground level.

76. Self-Propelled and Tank Mounted Weapons

a. Large caliber self-propelled weapons have a very limited traverse without turning the vehicle, and for this reason it is seldom practical to construct emplacements for them. When positions are prepared a sloped ramp is incorporated into the position to facilitate the vehicle's entry into and withdrawal from the gunpit. When operating in extremely cold weather, flooring or graveling the pit may be necessary so that the tracks of the vehicles will not freeze to the ground. The rear of the pit and the sloped ramp should be widened sufficiently to permit driving the vehicle in at an angle in order to compensate for the limited traverse of the weapon.

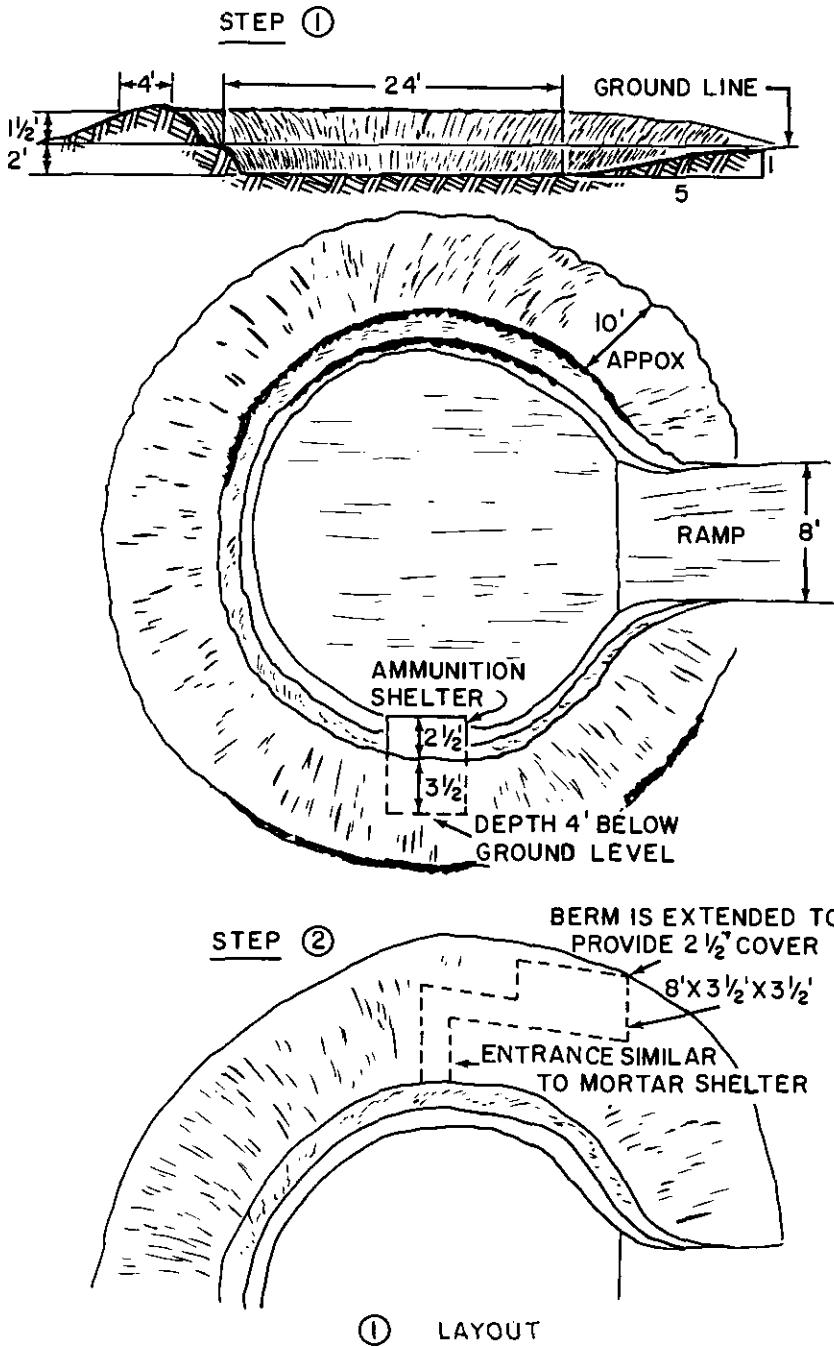
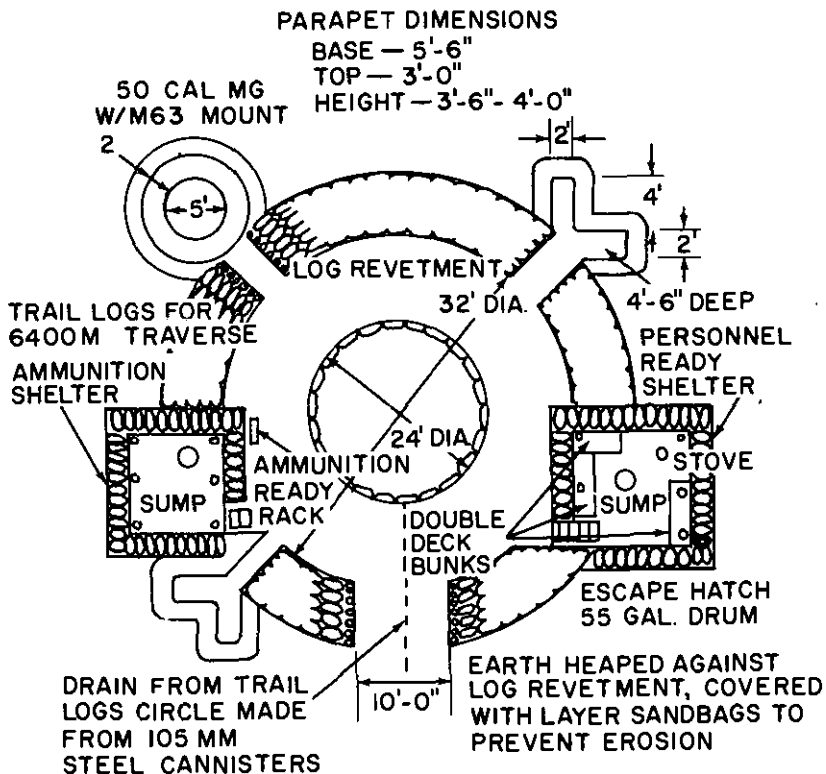

Figure 64. 105-155-mm howitzer emplacement.



② COMPLETED EMPLACEMENT

Figure 64—Continued.

b. A self-propelled weapon mounted in a revolving turret is emplaced or protected in the same manner as any other vehicle. Natural defilades such as road cuts or ditches are used where available. In open areas, parapets are provided to protect the sides and front of the hull of the vehicle, and the rear is left open. The simplest form of a dug-in position of this type is shown in figure 66. Wherever possible such positions are constructed and occupied during darkness, with all camouflage being completed before dawn. The emplacement normally includes foxhole protection for personnel on relief, preferably connected with the emplacement by a short trench.

A dug-in emplacement of this type should have the following:

- (1) An excavation deep enough to afford protection for the tracks and part of the hull of the vehicle with maximum thickness of parapet at the front of the emplacement and the rear left open for entry and exit of vehicle.

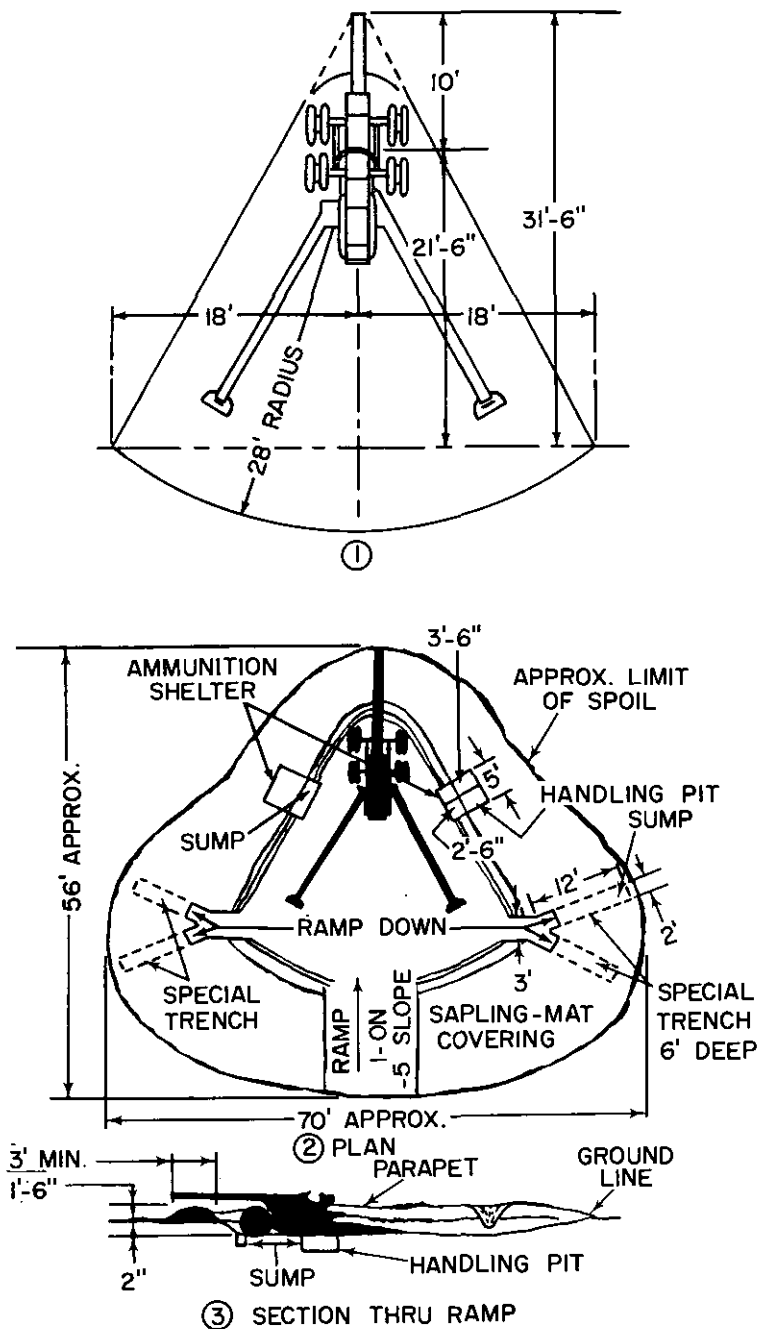
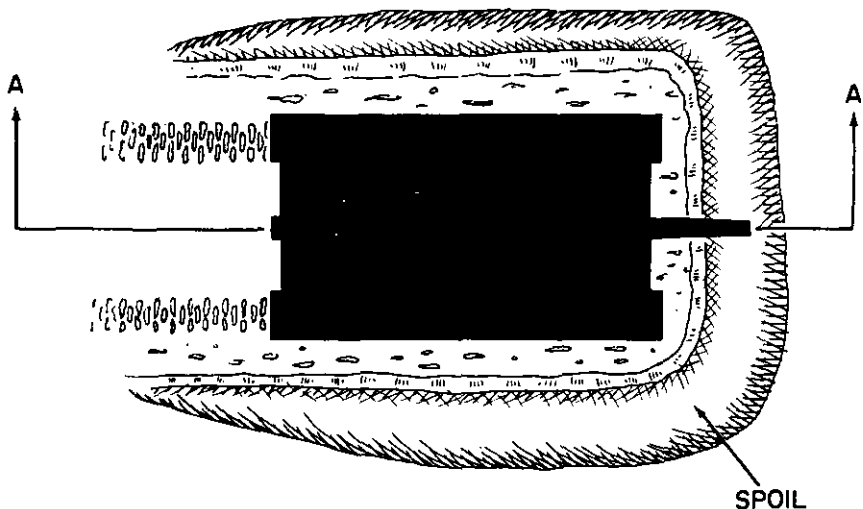
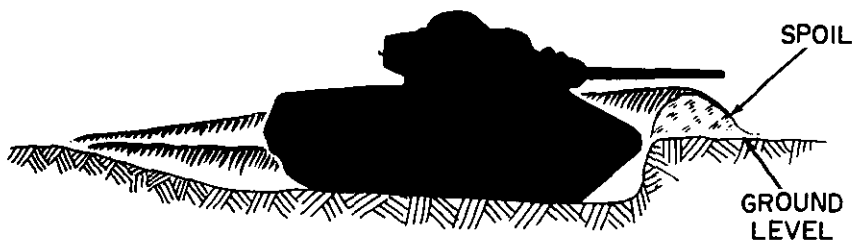

Figure 65. 8-inch howitzer, 155-mm gun emplacement.



PLAN VIEW



SECTION A-A

CAMOUFLAGE NOT SHOWN

Figure 66. Dug-in emplacement for self-propelled weapon.

- (2) Inside dimensions just large enough to permit entry and exit of vehicle. For self-propelled artillery weapons sufficient space must be available for storage of ammunition and movement of cannoneer.
- (3) An inside depth permitting the weapon to depress to its minimum elevation.
- (4) Barrel stops, if necessary, to prevent fire into adjacent units.
- (5) Provisions for drainage (if possible) and frostproof flooring is required to prevent tracks from freezing to the ground.

- (6) If it is necessary to deliver fire at elevations higher than permitted by the carriage design, the floor must be sloped upward in the direction of fire.

77. Shelters and Accessory Structures

a. Ammunition Shelters. A cut and cover, post-cap-stringer type structure such as is illustrated in figure 47 may be used with overhead cover as an ammunition shelter in conjunction with all types of weapons emplacements.

b. Personnel Ready Shelter. The personnel ready shelter is similar to the ammunition shelter.

c. Accessory Structures. Accessory structures, such as fire direction centers and switchboard shelters, are constructed using standard shelter designs.

78. Progressive Development

Artillery weapons emplacements are constructed so as to allow for continuous improvement in order to provide additional protection and comfort in the event of prolonged occupation. These emplacements are developed in stages as described *a* through *d* below.

a. Stage 1. This stage provides open foxholes for the protection of the crew and open emplacements for infantry weapons used to defend the position. Provision is made for only minimum essential shifting of the gun trail and ammunition is stored in the open. Stage-one emplacement for a 105-mm howitzer, is illustrated in 1, figure 67.

b. Stage 2. This stage provides trail logs for all around traverse of the weapon, a low parapet to protect the weapon, and covered emplacements for the crew, defensive weapons, and ammunition. Stage-two emplacement for a 105-mm howitzer, is illustrated in 2, figure 67.

c. Stage 3. In this stage a parapet revetted on the inside which permits all around direction fire is provided. Work is begun on covered shelters for personnel and ammunition. Stage-three emplacement for a 105-mm howitzer, is illustrated in 3, figure 67.

d. Stage 4. In this stage revetment is provided for the ground fighting positions and for the outside and top of the parapet. Overhead cover is also provided for the personnel ready position and the ammunition shelter. Stage-four emplacement for a 105-mm howitzer, is illustrated in 2, figure 64.

e. Use of Overhead Cover. In general, it is usually difficult to provide overhead cover for artillery weapons. The widths and heights involved make such construction impractical under most conditions. Such overhead cover would also unduly restrict the firing capability of the weapon. In addition, under most conditions, it is not desirable to excavate an emplacement for the weapon much below ground level or to construct a high all-around parapet for the following reasons:

- (1) A high all-around parapet restricts the direct fire capability of the weapon.
- (2) Emplacements excavated below ground create difficulty in providing for the rapid removal of the weapon from the emplacement.



Figure 67. Progressive development of 105-mm howitzer emplacement.

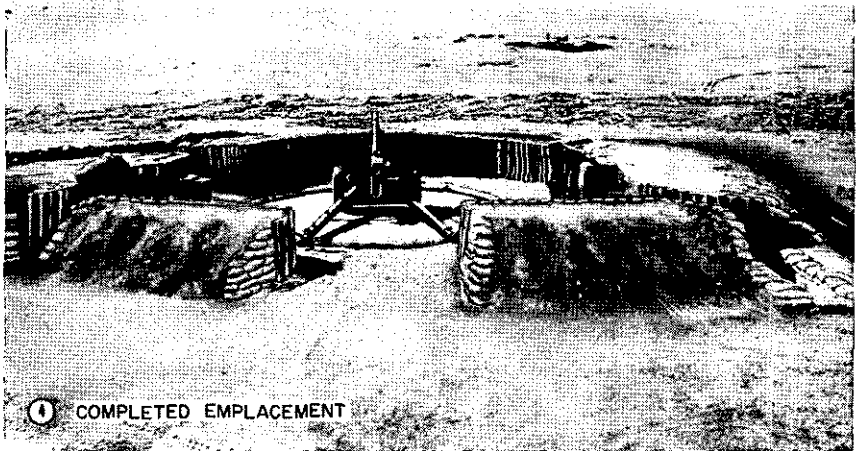
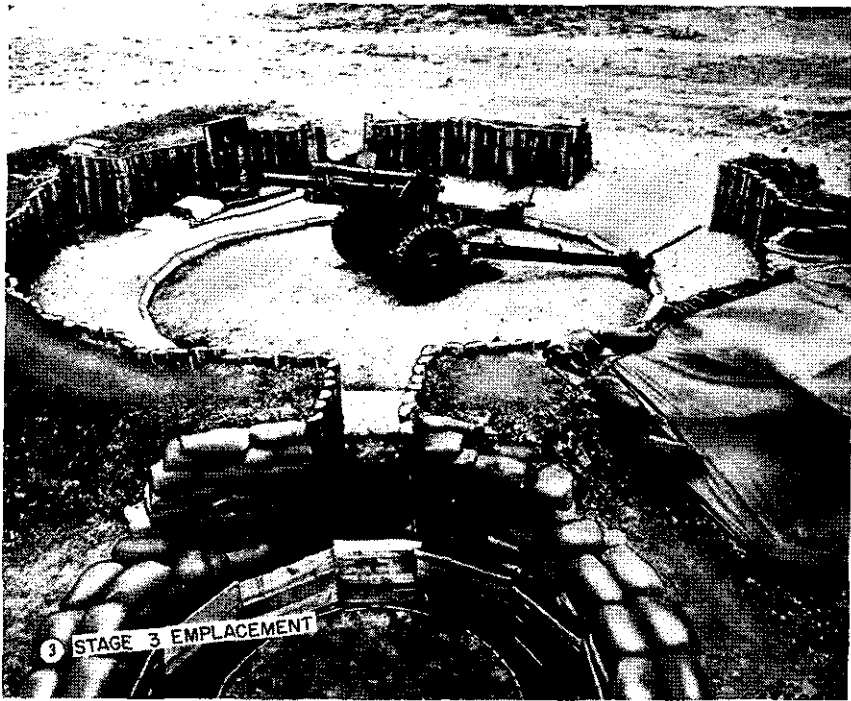

Figure 67—Continued.

CHAPTER 11

ACCESSORIES FOR EMPLACEMENTS AND SHELTERS

Section I. FIRING PORTS

79. Open Apertures

a. Apertures above the ground surface are generally undesirable because of their vulnerability to both nuclear weapons and direct fire conventional weapons and because of the difficulty of concealing them. In some cases however, the requirement to be able to fire or observe while under indirect artillery fire may be a prerequisite and apertures may be necessary. The location and size of an aperture are determined primarily by the operational characteristics of the weapon and by the desired field of fire. Large apertures permit better coverage of fields of fire but are more vulnerable to enemy weapons.

b. Figure 68 shows schematically three methods of placing sandbags or similar materials in and around apertures to provide lateral protection. Their advantages and disadvantages are as follows:

- (1) Type A (fig. 68) provides better observation than the others but is more difficult to conceal because of its wider outer opening. The type is not used in hard materials, such as masonry, which might deflect bullets or fragments into the gunner's face. It may be used for ports intended for observation only. These require less height than firing ports and for this reason are easier to conceal.
- (2) Type B (fig. 68) the reverse of type A, has its widest opening toward the inside of the emplacement. Of the three, this type affords the most protection but it requires the most change of position of the gunner or the weapon. It is used only where fields of fire are relatively restricted in width or in relatively thin masonry walls.
- (3) Type C (fig. 68) is a compromise between types A and B. It provides an adequate angle of vision and does not require excessive movement of the gunner or the weapon. It is used in loopholes through earth parapets and may also be used in walls that are too thick for satisfactory use of type B. In hard materials the outer part of the opening is formed in steps, to reduce deflection of bullets or fragments into the emplacement.

c. The angle of fire provided by these apertures may vary according

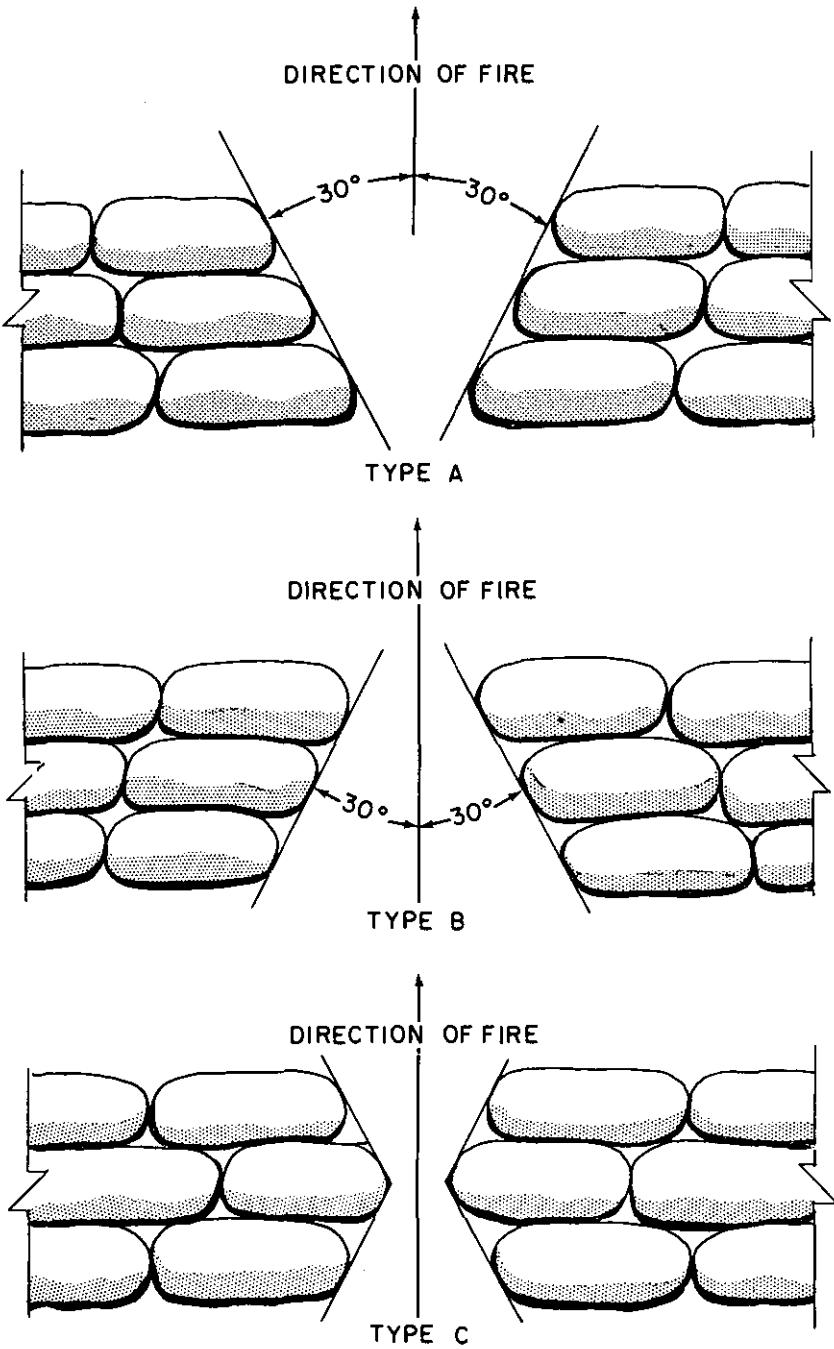

Figure 68. Types of apertures.

to the situation. With types A and B it is usually limited to 60°, 30° to the right and to the left of the principal direction of fire, but type C can readily be arranged for a 90° angle of fire. The smallest width is usually 4 inches.

80. Shuttered Apertures

Apertures may be shuttered when not in actual use, for concealment, for protection against fragments and against some of the effects of nuclear weapons, or for both concealment and protection. An opening in a wall or parapet is readily recognized by its rectangular shape and, in a position with overhead cover, by its dark background. Any covering, such as an empty sandbag on a light wooden frame, provides concealment and is otherwise satisfactory in some situations. More substantial material, such as a steel plate or several layers of plank, is required for protection against fragments or bullets.

81. Antigrenade Netting

A grenade net fastened to the overhead cover above the aperture and sloped toward the enemy to a sump provides excellent protection against grenades the enemy may attempt to throw into the emplacement. Chicken wire or camouflage netting is satisfactory for the purpose. Such a netting does not interfere with the firing of weapons, but does prevent troops within the emplacement from throwing grenades.

82. Aprons

Additional protection and effectiveness can be provided for an emplacement with overhead cover by constructing aprons over the apertures as illustrated in figure 69. The apron makes the emplacement much easier to conceal and aids materially in hiding the flash from the weapon. The overhead cover can be extended out on the apron making the thickness over the emplacement itself considerably greater. The length of the posts is adapted to the contour of the ground and the required field of fire for each position. Aprons will normally be quite vulnerable to blast from nuclear weapons.

Section II. ILLUMINATION

83. Flame Illumination

Sources of light that employ flame include gasoline lanterns, candles and kerosene lamps. Open-flame lights consume oxygen and, for this reason, are not satisfactory for prolonged use in unventilated or poorly ventilated emplacements or shelters.

a. Gasoline Lanterns. Gasoline lanterns provide a very satisfactory open-flame light. If used extensively, it is advisable to procure un-

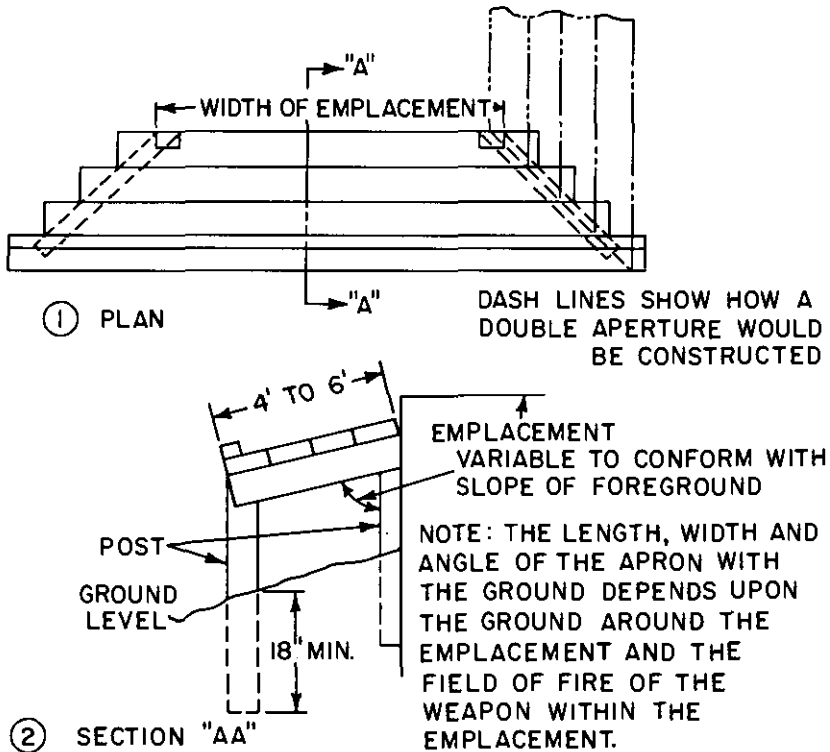

Figure 69. Apron for standard emplacement.

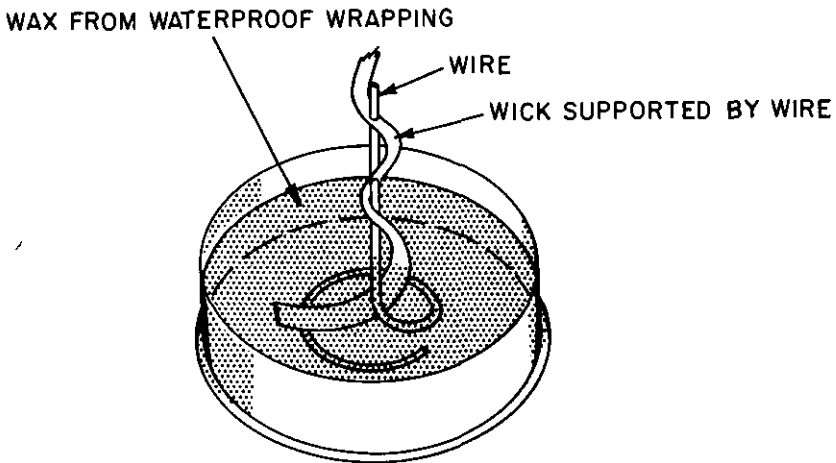

Figure 70. Improvised candle.

treated gasoline for fuel locally or from a quartermaster unit; the use of treated motor gasoline blackens mantles.

b. *Candles.* Candles are not satisfactory for extensive use as open-flame light but should be available for emergency use. Candles with suitable holders are the best type of flame illumination for frontline positions. Candles can be made from the water proofing wax that covers certain items, such as parts for equipment and weapons. This wax is collected and placed in a shallow can such as the jam can from types of field rations. A felt wick is placed in the can and supported by a wire or small metal strip as shown in figure 70.

c. *Kerosene Lamps.* Kerosene lamps can be improvised using a ration can and empty cartridge as shown in figure 71.

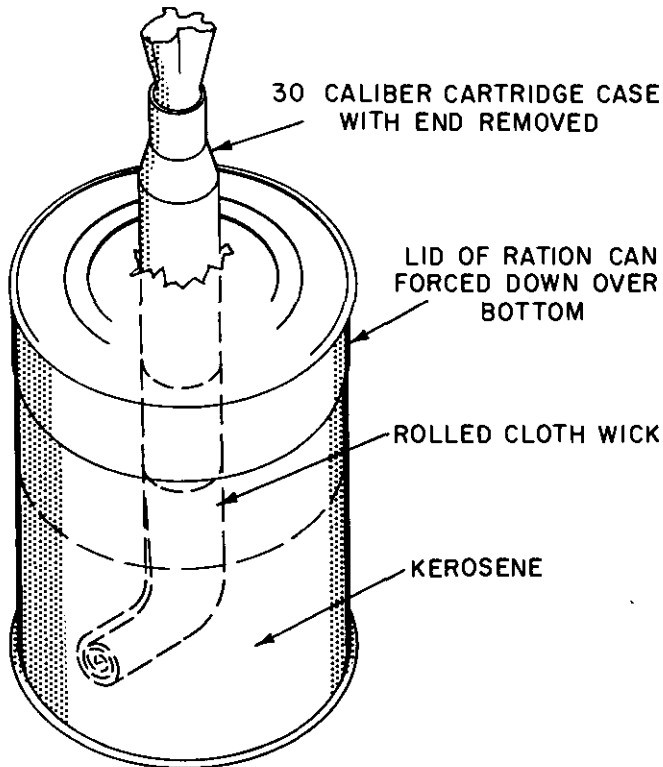

Figure 71. Improvised kerosene lamp.

84. Electricity

a. Electric lights provide the most satisfactory illumination for shelters and emplacements but are usually not feasible for front-line installations because of light security regulations. Sources of current include dry-cell batteries (flashlights and instrument lights), wet-cell

batteries (automotive equipment electric systems), and portable electric generators. Dry-cell batteries provide silent operations; the other sources require engine driven generators which may disclose the position by their sound. When the engine can be provided with a flexible exhaust tube, much of the noise can be eliminated by placing the end of the tube in a hole similar to a fox-hole and covering the hole with boards or similar material. The engine noise of portable generators may be reduced by inclosing the generator in a shelter or other excavation. The inclosure requires an ample air supply and ventilation, for carburetion and cooling.

b. In rear areas or in nonfighting positions where some noise is permissible, portable generators are used to provide current. In this type of installation the generators must operate continuously during the hours when illumination is required. Standard portable electric generators are provided in tables of organization and equipment for certain units. They supply 115-volt, singlephase, 60-cycle alternating current, for which wiring and fixtures, with adequate fuse protection, must be installed by qualified personnel. Wire types must be suitable for exposure to dampness, and wire sizes must be large enough to avoid excessive voltage loss in lines. Standard 115-volt incandescent bulbs can be used with 110-115-volt alternating current.

c. If noise is permissible during a few hours in each 24-hours period, emplacements in forward areas may be illuminated by 6- or 12-volt automotive type bulbs supplied by wet-cell automotive storage batteries, to be charged daily by small standard generators, each with a battery charger. This permits continuous use of lights if necessary, with intermittent generator operation. Due to the small capacity of an arrangement of this type, lights are small and are used sparingly. Long lines of wire are avoided by installing a generator-charger.

d. Expedient lighting systems may be developed from salvaged parts of wrecked vehicles. Vehicle headlights may be used as overhead lamps; and by operating the motor intermittently, the battery of the vehicle provides electric current. The generator charging rate should be set at the highest position permitted by the capacity and condition of the battery. A muffled automotive engine makes less noise than the engine of the standard generator sets.

e. A very useful lighting expedient consists of a 25-watt, 110-volt incandescent bulb connected to the 90-volt terminals of a dry battery provided with such terminals and used in some types of radio equipment. Such batteries have a short life in radio service, but when un-servicable for use in radio, they will provide intermittent illumination from a 110-volt bulb for an additional several hours.

Section III. ENTRANCES

85. Blast Protection

The conditions which influence blast effects on fortifications are so varied that only general rules for entrance design may be given. Completely blast proof entrances for field fortifications are generally not feasible because of the strong construction required. Small, baffled entrances and entrances with baffles or right angle turns will reduce drag forces inside, keep debris from being thrown in and will provide some reduction in inside overpressures. Entrance ways should be strong enough so that the structural members of the entrance itself are not blown into the shelter. Overpressures within shelters, can vary from less than half to twice the incident overpressure.

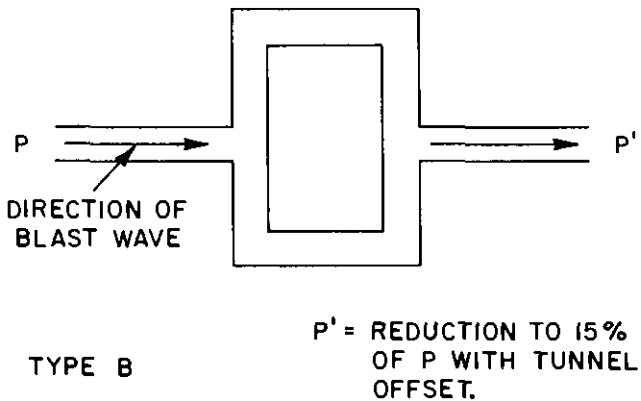
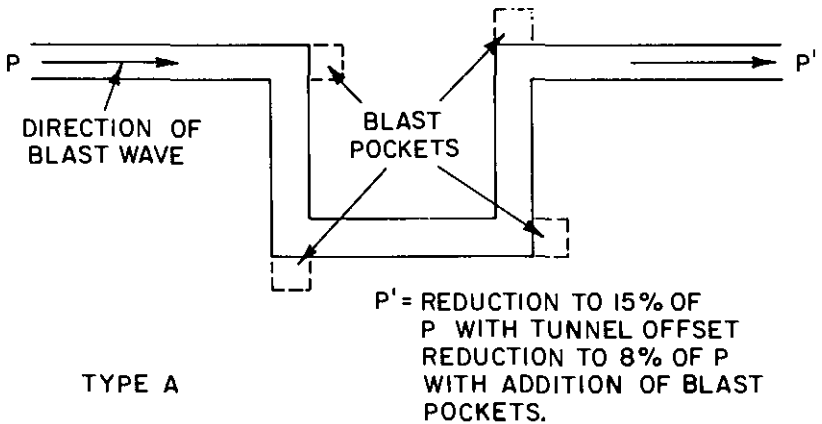

Figure 72. Blast traps in a tunnel type entrance.

86. Protection From Chemical and Biological Agents

In order to provide the occupants of emplacements and shelters sufficient protection from chemical and biological agents so that the wearing of protective masks is not necessary, special construction of shelter entrances is required. The construction of such entrances is covered in TM 3-350.

87. Light Security

If light proof blast baffle walls or gasproof air locks are not provided, blackout curtains should be installed in the entrances to all shelters to prevent light leakage from disclosing the position. To be most effective, blackout curtains are hung in pairs so that one shields the other and prevent light leakage when a person passes through the entrance. When other materials are not available, issue blankets may be used as blackout curtains.

88. Emergency Exits

Emergency exits in larger shelters are desirable in case the main exit becomes blocked. Such exits should be made more blast-resistant than the main entrance. This can easily be done by making them just large enough to crawl through. Corrugated pipe sections or 55-gallon drums with the ends removed are suitable for use in constructing this type of exit. A simple emergency exit which is highly blast-resistant can be constructed by sloping a section of corrugated pipe from the shelter up to the surface, bracing a cover against the inside, and filling the section of pipe with gravel. When the inside cover is removed, the gravel will fall into the shelter, and the occupants can crawl through the exit with no digging effort required.

89. Construction of Air Locks

Air locks are chambers between two improvised gasproof curtains, constructed to reduce the entrance of gas into a shelter when personnel enter or leave. The volume of air in the lock is kept to the minimum practicable, to reduce the movement of contaminated air into the lock when the outer curtain is opened. Figure 73 gives details for an air lock of minimum dimensions, suitable for use with most types of shelters. Figure 74 gives details for a similar lock for use in aid shelters. It is elongated sufficiently to admit a litter with two carriers. Either of these structures can be modified to provide additional headroom if necessary. If the outer door frame of the air lock projects in front of the earthwork of the entrance, the door opening is reduced so that the curtain is 4 inches wider and 4 inches longer than the door frame. If the outer door frame is recessed in earthwork, the door frame may be the same width as the improvised curtain. The air-lock framing details provide recessed shelves above the door frames to receive the rolled-up

curtains when they are not in use. When gas attacks are expected, a brush and a bucket of soapy water (preferably hot) is kept available at the entrance of shelters. If the area is contaminated, men scrub boots with soapy water before entering shelters.

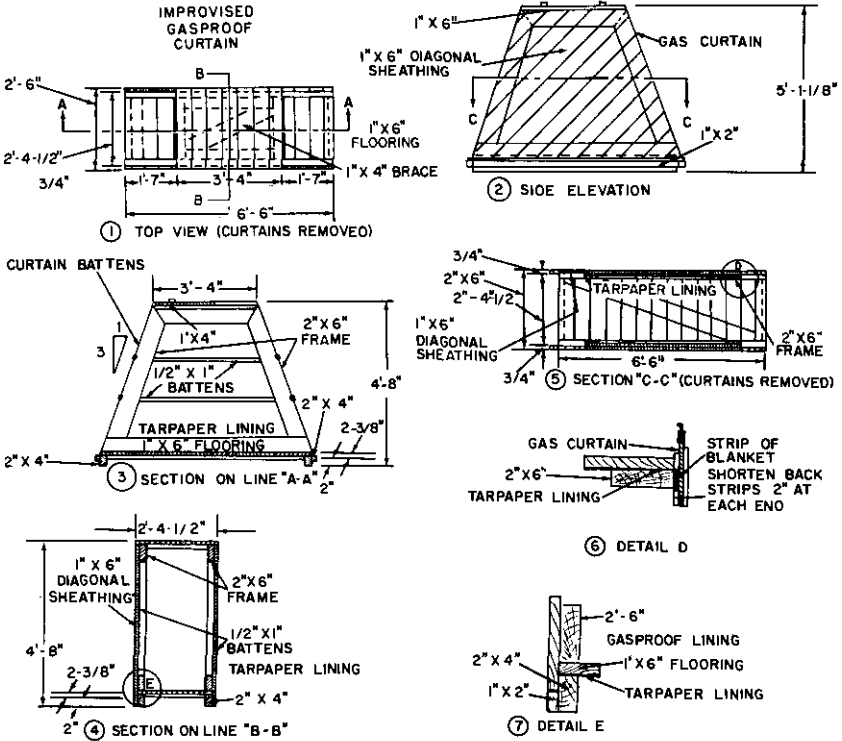
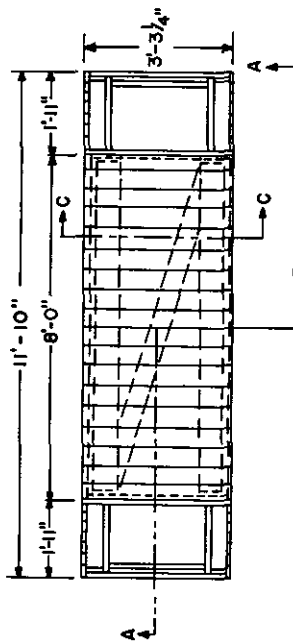
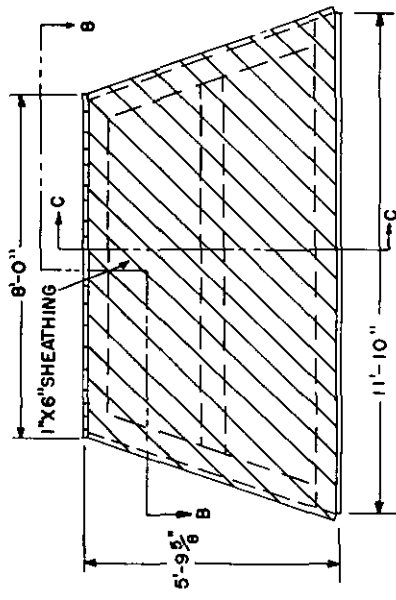

Figure 73. Standard air lock for shelter.



① TOP VIEW (CURTAINS REMOVED)



② SIDE ELEVATION (CURTAINS REMOVED)

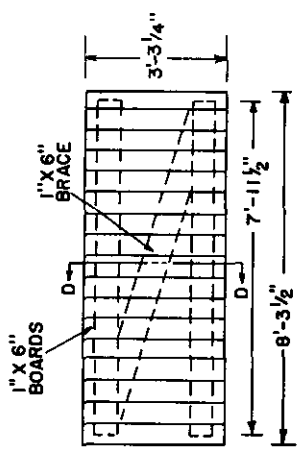

③ TOP VIEW OF ROOF PANEL

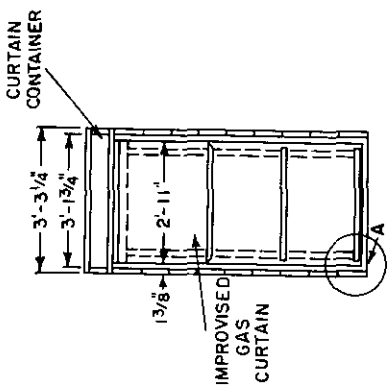

④ FRONT ELEVATION

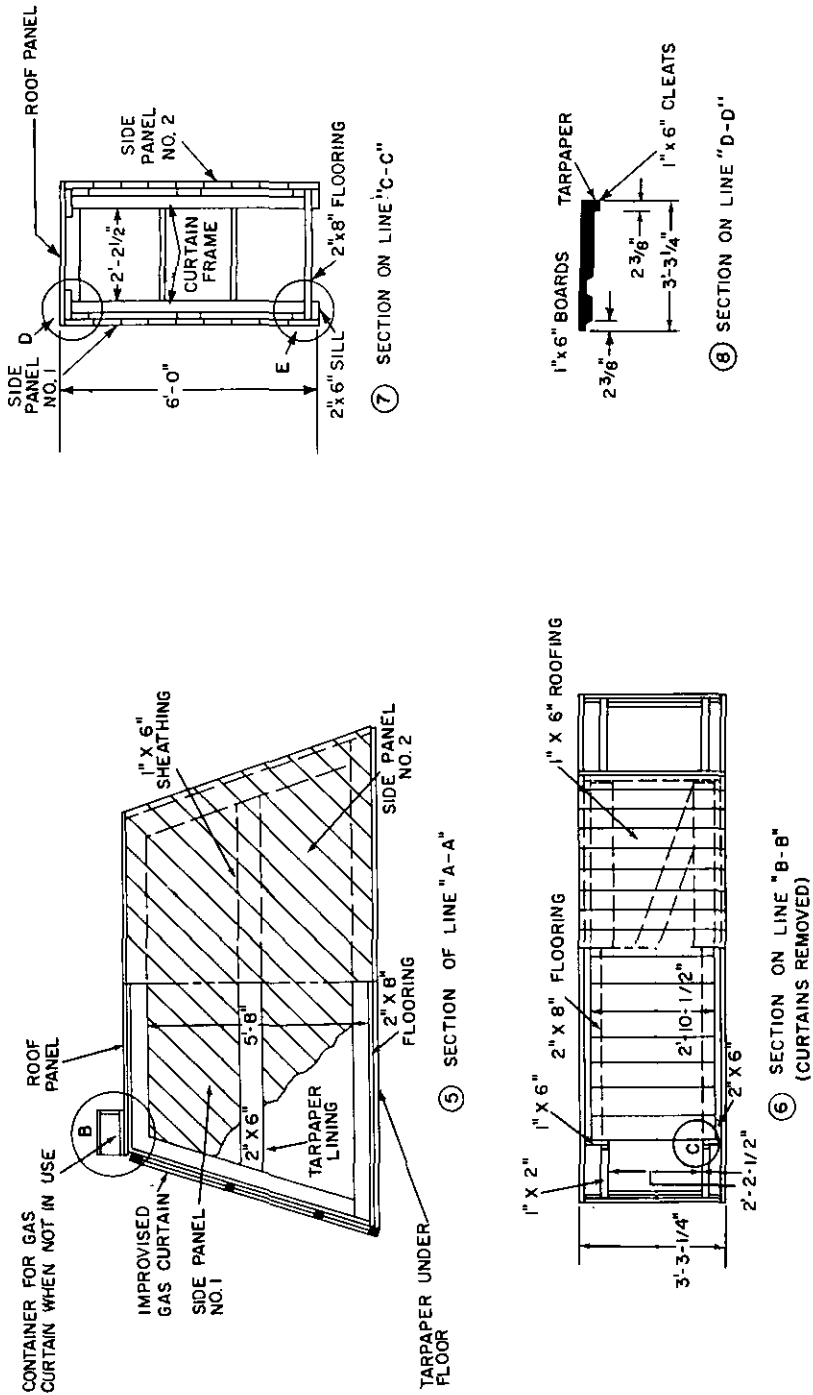
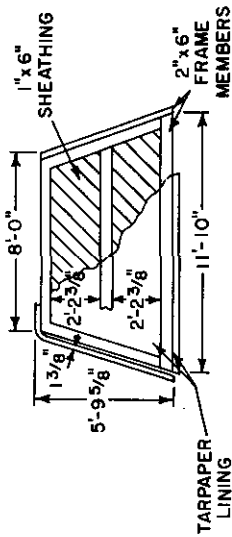
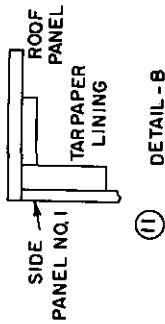

Figure 74. Air lock for aid shelter.



⑨ INSIDE VIEW OF SIDE PANEL NO. 1
(SIDE PANEL NO. 2 SAME--REVERSED)



⑪ DETAIL - B

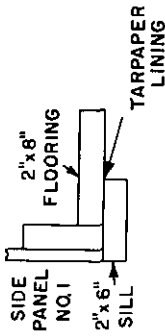

⑫ DETAIL - C

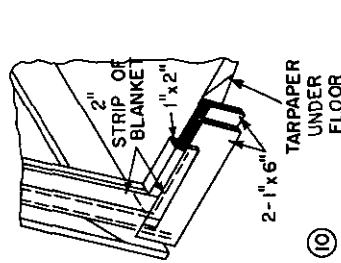

⑩ ISOMETRIC OF DETAIL - A

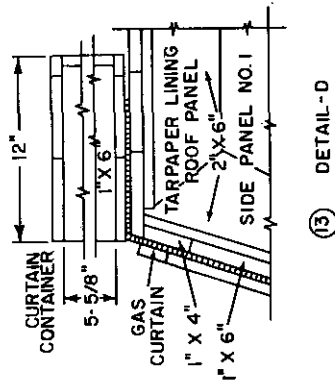

⑬ DETAIL - D

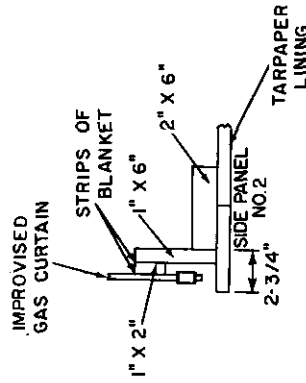

⑭ DETAIL - E
(GAS CURTAINS REMOVED)

Figure 7.4—Continued.

Section IV. HEATING

90. General

During cold weather it is often necessary to provide some type of heat for both emplacements and shelters. Issue stoves are not normally available for heating of shelters and emplacements and even if available they are too large to be used in most emplacements. Heating presents many problems that must be solved for each particular situation. During daylight the smoke gives away the location of a position, and at night the light sparks of glow must be shielded. Fuel is normally difficult to obtain in forward areas and may have to be transported long distances. Most fuels may be burned without a stove but it is never safe to have an open fire in a closed shelter. Gases resulting from incomplete combustion may be very toxic. All heating in shelters should be by some type of stove which is properly vented to remove the burned gases from the shelter.

91. Fuels

a. Charcoal is an excellent fuel for emplacement heating because it gives off very little smoke or light and will burn for a long time. It is also lightweight, easily transported, and relatively safe to handle and use.

b. Coal is also relatively safe and easy to handle, but is heavy, difficult to ignite, and gives off both light and smoke. Coke has some of the advantages of charcoal, in that it is lightweight and burns long with little smoke or light, but it is more difficult to ignite.

c. Diesel fuel is usually available and is easily transported but it is dangerous to burn as fuel in shelters or emplacements, and it gives off both smoke and light.

d. Gasoline is usually available and easy to transport. It can be burned with little or no smoke. It is very dangerous to use in either a shelter or an emplacement and gives off light.

e. Wood is usually the most plentiful fuel. It is easy to handle and transport, is relatively safe, and gives good heat. It cannot be burned without giving off some smoke and light, however, and there is the further disadvantage that large quantities are required compared with other fuels.

92. Stoves

Some improvised stoves for burning coal, coke, wood, or charcoal are shown in figure 75. An improvised gasoline or diesel fuel stove is shown in figure 76. This stove provides easily controllable heat with the fuels most likely to be available, but can be extremely dangerous if not carefully operated. This type can be adapted to various types of containers if the same principles are employed. The essential items required for

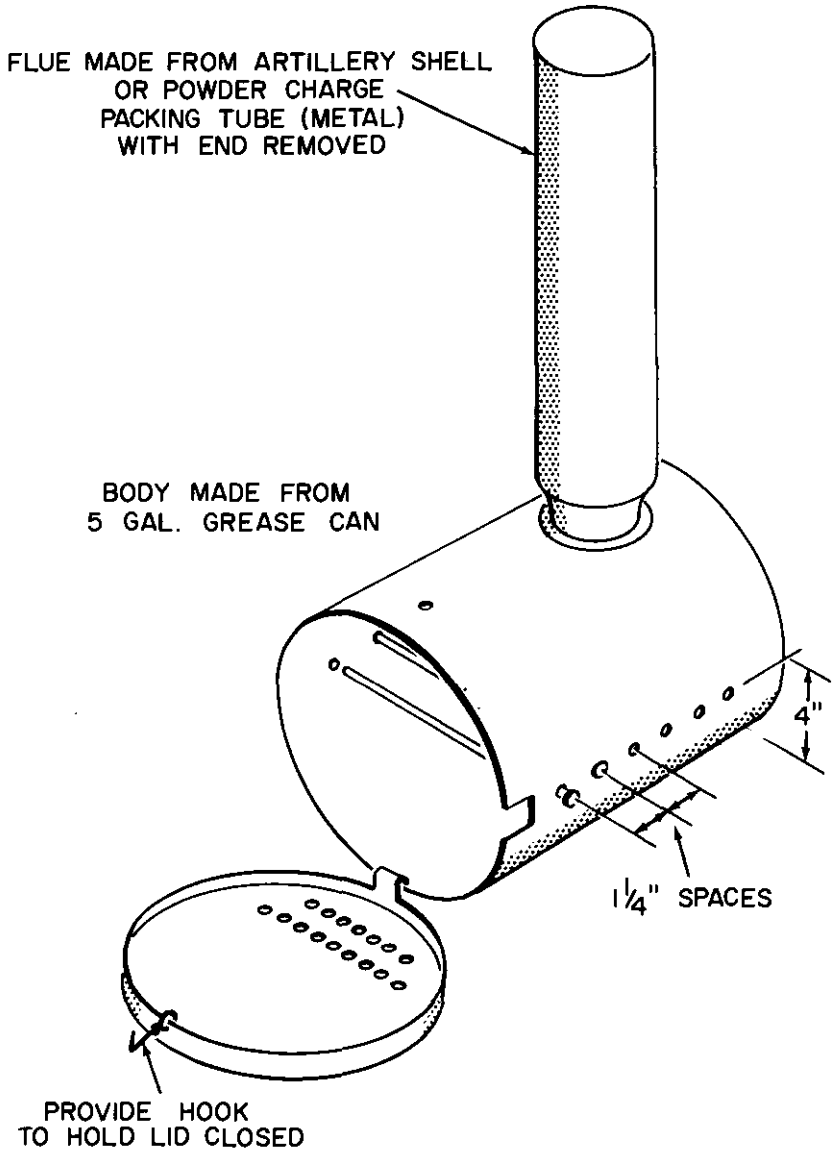

From grease can
Figure 75. Improvised stoves.

BODY MADE FROM
5 GAL. OIL CAN

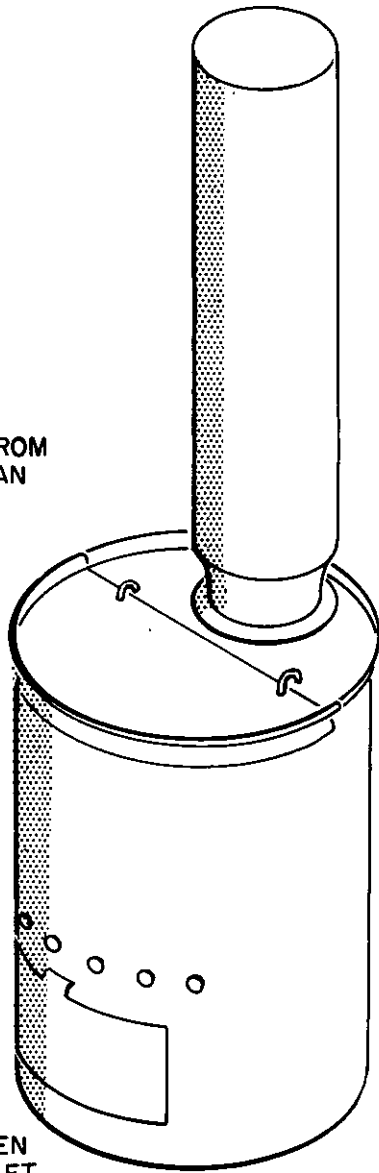

PROP DOOR OPEN
TO CONTROL DRAFT

From 5-gallon oilcan
Figure 75—Continued.

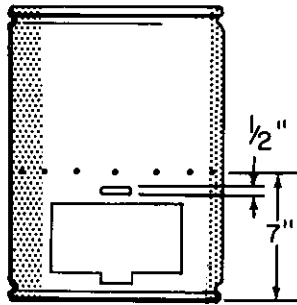
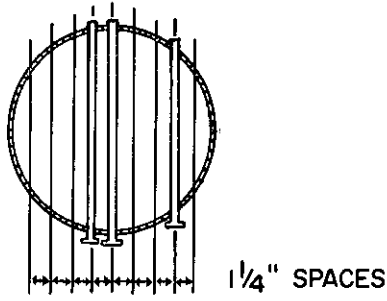

CUT SECTION FOR DRAFT AND CLEANOUT LEAVE TABS AS SHOWN
 INSERT IN SLOT FOR HINGE



HINGE LID WITH HEAVY WIRE OR NAIL

BEND TAB AS SHOWN

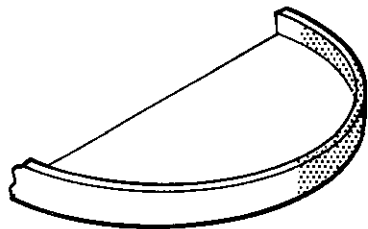
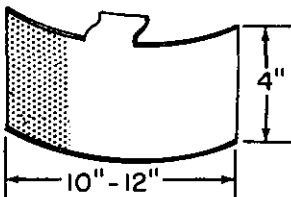

CUT OFF HALF OF TOP FOR LID

From 5-gallon oilcan—Continued

Figure 75—Continued.

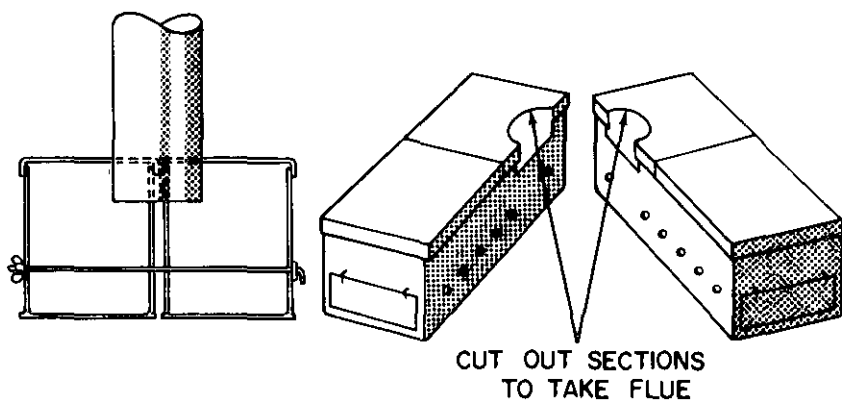
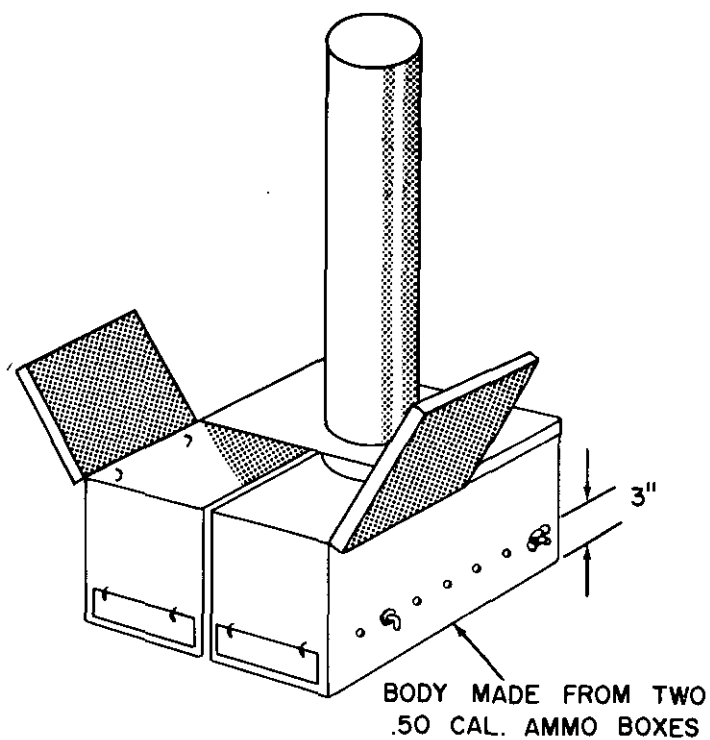

From two .50 cal ammunition boxes

Figure 75—Continued.

BODY MADE FROM
ARTILLERY FUSE BOX

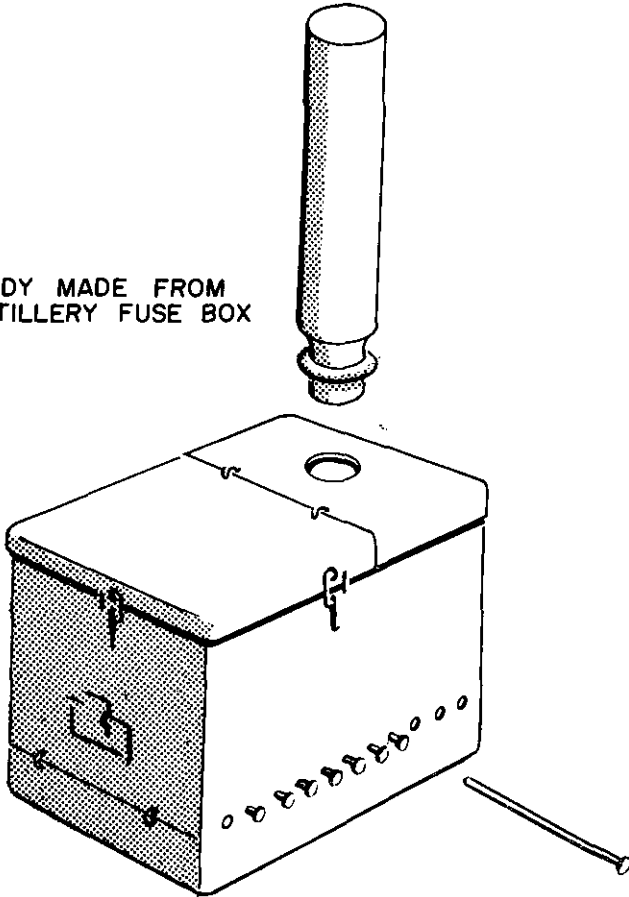

From fuse box

Figure 76—Continued.

the construction of this stove are a petcock and a piece of copper fuel tube long enough to supply fuel from an improvised tank located outside the shelter and at a safe distance from the entrance. The tube and tank can be obtained from a wrecked or salvaged vehicle. The stove is downdraft type and special instructions are required for its proper operation. To light the stove, close off the air and fuel intake at the top of the stove. Then open the door at the bottom. Next light a piece of paper and place it in the stove. Let the paper burn until the stove starts to draw well. Then open the air and fuel intake opening at the top of the stove and close the door at the bottom. Next open the fuel petcock. Adjust the flow of fuel until the stove is burning as desired. At each stove of this type the following warning should be posted: **Do not turn on the fuel before lighting the stove with paper. To do so may cause an explosion or backflash that will burn the person lighting**

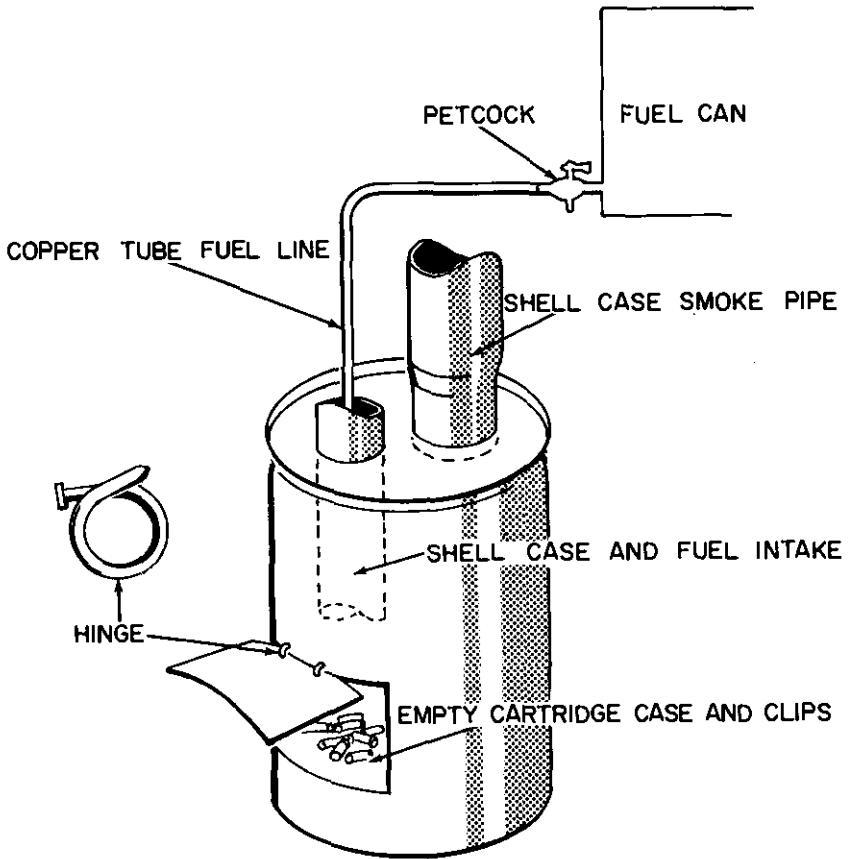

Figure 76. *Improvised oil burning stove.*

the stove. The cartridge cases and clips in the bottom of the stove acts as the igniter. They become very hot after the stove is in operation for a few minutes and then when the fuel flow is cut very low, the fuel drips on the hot shell cases and ignites.

93. Underfloor Heat

For fuel economy underfloor or radiant heating is the most efficient method of heating closed shelters with earth floors. Underfloor heat may be developed in several ways but consists primarily of running the smoke vent under the floor of the shelter. The vent should be covered by at least 3 inches of earth floor and may be constructed of metal boxes or cans with their ends removed or of sheet metal rolled into a round pipe. The firebox is dug into the floor of the shelter or dug outside the shelter with the flue passing under the floor. Where the material is available 2 or 3 vents should be constructed under the floor for increased efficiency, as indicated schematically in figure 77. The

fire pit may be a dug out with a sheet metal cover or one of the stoves illustrated in figure 75 with a vent at the back instead of at the top of the stove.

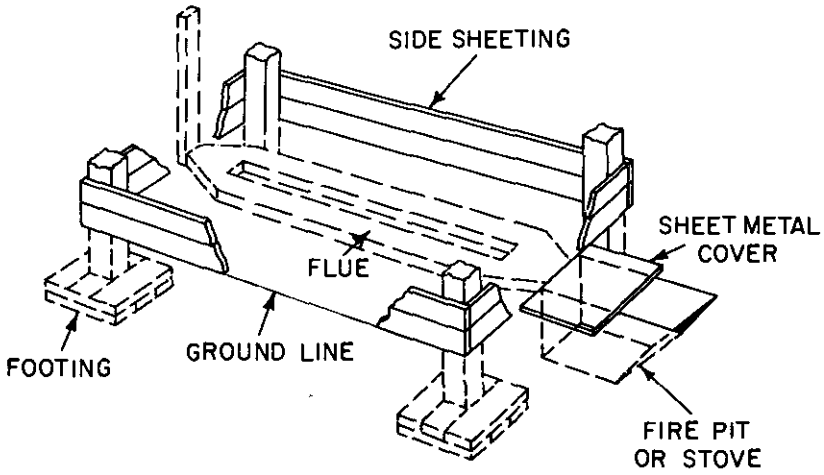

Figure 77. Underfloor heating.

PART FOUR
OBSTACLE EMPLOYMENT
CHAPTER 12
GENERAL

94. Definition

An obstacle is any terrain feature, condition of soil, climate, or man-made object other than fire power, that is used to stop, delay, or divert movement.

95. Purpose

Obstacles play an important part in warfare. They restrict the movements of forces, delaying them and requiring them to regroup. Obstacles should not be considered solely as passive defense measures but should be included in the overall defense plan.

96. Uses

a. A sufficient number of well sited and concealed obstacles, when used in conjunction with antipersonnel mines, can adversely affect the morale of the enemy.

b. When the enemy force attempts to cross an obstacle it must first establish a bridgehead. Until this bridgehead is established, the enemy is in a vulnerable spot where a defeat could be inflicted by a comparatively small force.

c. Obstacles are used offensively to anchor a flank or flanks of an advancing unit. They are also created behind enemy lines to delay, disorganize, and harass troop movements and communications. This latter measure is particularly effective when the enemy force is withdrawing.

d. If the enemy force has nuclear weapon capabilities, the operational plans of the friendly force may include dispersion, with wide intervals between units of company size or larger (ch. 5). Such intervals should be blocked by a combination of obstacles and fire power.

97. Classification

Obstacles are divided into two general classes depending on whether they are existing or are constructed for the express purpose of hindering movement.

a. *Natural*. A natural obstacle is any existing object or condition that is used to hinder movement including manmade objects not constructed as obstacles but used as such. Natural obstacles include swamps, rivers and streams, mountain ranges, climatic conditions, irrigation canals, and existing buildings or walls.

b. *Artificial*. An artificial obstacle is any manmade object constructed to hinder movement. Artificial obstacles include minefields, antitank ditches, contaminated areas, hedgehogs, road craters, demolished bridges, and barbed wire. It may be constructed entirely on land or partially under water as in the case of beach and river line obstacles.

c. Obstacles can be divided into 3 groups according to their uses. Seldom does an obstacle fall clearly into 1 of these 3 groups. More often than not an obstacle serves in 2 or all 3 capacities. This arbitrary classification of obstacles merely clarifies their primary uses.

- (1) *Protective*. Protective obstacles are those obstacles used to provide security. Obstacles of this type are usually artificial and include such items as wire, minefields, and various warning devices. They are intended primarily to prevent the enemy from making a surprise assault from areas close to a position.
- (2) *Defensive*. Defensive obstacles are obstacles used to delay the enemy force in areas where it can be engaged with heavy, intense, defensive fire. They may be either natural or artificial. A defended road block or an obstacle in front of a defensive position which stops or delays the enemy force once it is in range of defensive weapons are examples of this type. Defensive obstacles should be covered by appropriate fire, kept under observation, and should be employed in conjunction with protective obstacles.
- (3) *Tactical*. Tactical obstacles are obstacles used to break up enemy attack formations and channelize the enemy force into areas where it is blocked by defensive obstacles or can be brought under intensive defensive fires. This tactical obstacle delays, harasses or demoralizes the enemy by forcing it to employ dangerous or exhaustive breaching measures in areas not covered by fire.

CHAPTER 13

PRINCIPLES OF EMPLOYMENT OF ARTIFICIAL LAND OBSTACLES

Section I. GENERAL

98. Coordination With Tactical Plan

As previously stated obstacles should be tied in and coordinated with the tactical plan. All obstacles should contribute to the success of this plan, and all units concerned should know the location of and understand the purpose and type of obstacles employed. In addition all concerned should know when the obstacles are to be executed, and for how long they are to be defended. Only by coordination with all elements can an integrated plan be prepared that will use all elements of defense to their best advantage against the enemy.

99. Covering By Observation and Fire

a. Observation. If accurate fire is to be delivered on an obstacle or obstacle system it must be under observation. The observation and defense of obstacles for close-in defense is the responsibility of the unit occupying the ground. However, when an obstacle system covers a large area, observation is normally the responsibility of roving patrols, an outpost system, Army aviation or tactical air while their final defense is a mission for mobile forces than can be brought quickly to any point of the system. At times it is not feasible to have an obstacle under direct observation. When this is the case, warning devices or alarm systems such as trip flares, boobytraps, in connection with noise makers should be used.

b. Fire. Covering an obstacle by fire usually means the difference between causing the enemy only small delay and annoyance and forcing him into a costly engagement.

- (1) Both antivehicular and antipersonnel obstacles should be covered by both antivehicular and antipersonnel fire. Fire that covers antipersonnel obstacles should not only be capable of discouraging breaching, bypass, or capture by personnel but should also be capable of stopping any vehicles that may be used in the assault. Also, antivehicular obstacles must be covered by fire that will not only destroy vehicles but will prevent troops from breaching the obstacle and clearing a path for the vehicles.

- (2) Obstacles are best covered by direct-fire weapons, but when this is not feasible, observed artillery fire and tactical air should be used. Artillery covering obstacles should be prepared to deliver fire that is effective against both personnel and vehicles. When it is impossible to cover obstacles by fire they should be contaminated or heavily boobytrapped to cause the enemy to employ dangerous and exhaustive breaching measures.

100. Employment in Conjunction With Natural and Other Artificial Obstacles

It is fundamental that an obstacle system should usually be as difficult to bypass as it is to breach except when the obstacle is intended to divert or deflect the enemy rather than to delay or stop him. If this condition is to be achieved, artificial obstacles must be sited to take full advantage of natural and other artificial obstacles; also, to keep logistic and construction requirements at a minimum, natural obstacles are improved and exploited to their fullest extent as described in chapters 15 and 18.

101. Employment In Depth

Obstacles do not seriously hamper the enemy's movement until they overload or heavily tax his breaching capabilities. This cannot be accomplished unless obstacles are employed in depth. With the exception of contaminated areas it is usually prohibitive in time and materials to construct a large deep area of continuous obstacles. The same end is accomplished by constructing successive lines of obstacles, one behind the other, as time and conditions permit. These successive lines require the enemy force to continually deploy and regroup, thus dissipating, channelizing, and dividing its effort until friendly forces can destroy it or force its withdrawal.

102. Camouflage and Concealment

a. Obstacles should be camouflaged or employed in such a way that they come as a surprise to the enemy. When the enemy has no prior knowledge of an obstacle, he has to reduce it without benefit of prior planning. If the obstacle is defended the defender has the advantage of the enemy's first reaction, which is usually confusion, and the enemy may be caught without the men and material to breach the obstacle.

b. Proper siting is often the easiest solution to obstacle camouflage problems. Large obstacle systems cannot be concealed by siting alone, but when proper advantage is taken of the terrain and the obstacles are located in folds of the ground, around blind curves in roads, or just over the tops of hills, they can be made inconspicuous from the enemy's ground observation. To help camouflage obstacles from aerial observation, regular geometric layouts of obstacles and barrier systems should

be avoided and phony obstacles used to confuse the enemy as to the exact location and extent of the system.

c. Often the best way to conceal an obstacle is to postpone its execution or construction as long as possible, yet assuring that it can be done properly and in time. This cannot be done when large barrier systems are involved but is possible when preparing obstacles to block narrow avenues of approach, such as roads or bridges. Obstacles created by demolitions lend themselves readily to this procedure. When their use is contemplated they should be completely prepared, with firing the only thing left for the last minute.

103. Provision for Lanes and Gaps

Whenever obstacles are employed around a defensive position or area, lanes or gaps through the system are left and concealed. These lanes are provided so that patrols, counterattacks, and friendly troops on other missions may move through the system without difficulty. Under normal circumstances the lanes or gaps necessary to mount a general offensive through the obstacle system are not provided during construction, but prepared later when the need for them arises. It is of prime importance that there be a sufficient number of lanes to allow for alternate use and that they be concealed and changed periodically to insure that they are not discovered by the enemy. Prior plans must exist to insure that all lanes or gaps can be blocked quickly when enemy action is expected. Lanes and gaps should be covered by fire to preclude the possibility of the enemy rushing through them before they can be closed.

104. Affording No Advantage to the Enemy

Enemy forces may use certain obstacles to an advantage as they are breached or assaulted. Antitank ditches should be so constructed as to be useless to the enemy as fighting trenches. Log cribs should be so located that the enemy cannot deliver effective fire on defending weapons while using the crib as a breastwork. Care should be taken that obstacles are not located so that the enemy can use hand grenades against the defenders from cover or concealment provided by the obstacles. Barbed wire, mines, and boobytraps should be used extensively to deny use of any cover or concealment that might be provided to the enemy by natural or artificial obstacles. Care should be taken to guard against the inadvertent placing of an obstacle which might later hinder friendly maneuver.

Section II. MINEFIELDS

105. General

Minefields not only present an obstacle to the advance of the enemy but unlike obstacles of a passive nature, can also inflict significant

casualties; therefore minefields are considered the best form of artificial obstacle. The installation of minefields changes favorable terrain to unfavorable terrain and materially enhances the strength of the defense system.

106. Types

Mines and Minefields are covered in FM 5-31 and FM 20-32.

Section III. BARBED WIRE ENTANGLEMENTS

107. General

Barbed wire entanglements are artificial obstacles designed to impede the movement of foot troops and, in some cases, tracked and wheeled vehicles. The materials used in constructing barbed-wire entanglements are relatively lightweight and inexpensive, considering the protection they afford. Barbed-wire entanglements can be breached by fire but are rapidly built, repaired and reinforced.

108. Classification

Entanglements are classified according to their use and their depth and whether fixed or portable.

a. Use. Entanglements are classified by use as tactical, protective, or supplementary. The employment of these types in a defensive area is shown schematically in figure 78.

- (1) *Tactical.* Tactical wire entanglements are sited parallel to and along the friendly side of the final protective line. They are used to break up enemy attack formations and to hold the enemy in areas covered by the most intense defensive fire. Tactical entanglements extend across the entire front of a position but are not necessarily continuous.
- (2) *Protective.* Protective wire entanglements are located to prevent surprise assaults from points close to the defense area. As in the case of all antipersonnel obstacles, they are close enough to the defense area for day and night observation and far enough away to prevent the enemy from using hand grenades effectively from points just beyond the obstacle, normally 40 to 100 yards. Protective wire surrounds the individual units of a command, usually the platoons (fig. 78). These entanglements should be connected to entanglements around other platoons to inclose the entire defensive positions. Protective entanglements are erected around rear-area installations in the same manner and to serve the same purpose as protective wire around defensive positions in forward areas. Protective wire also includes the entanglements which should be installed over the tops of installations provided with overhead cover (fig. 79).

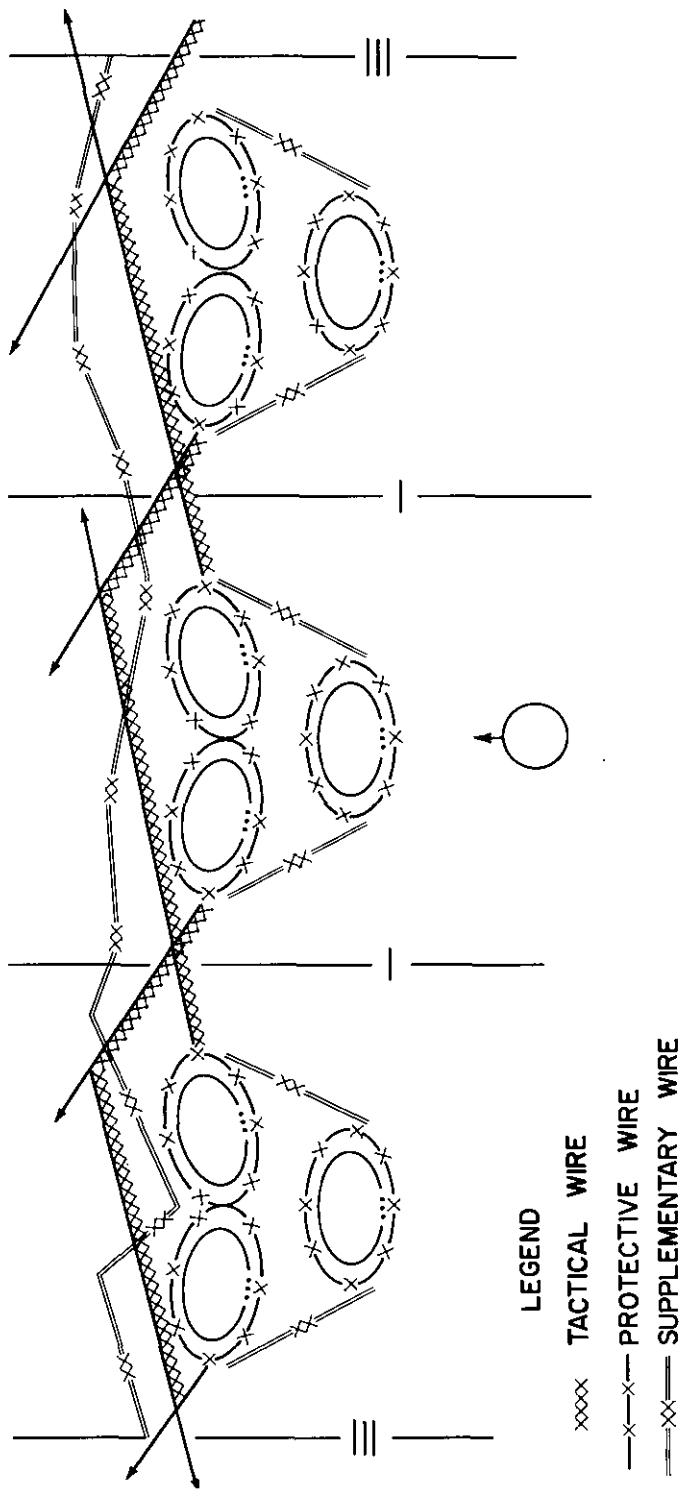

Figure 78. Schematic layout of barbed wire entanglements in defensive area.

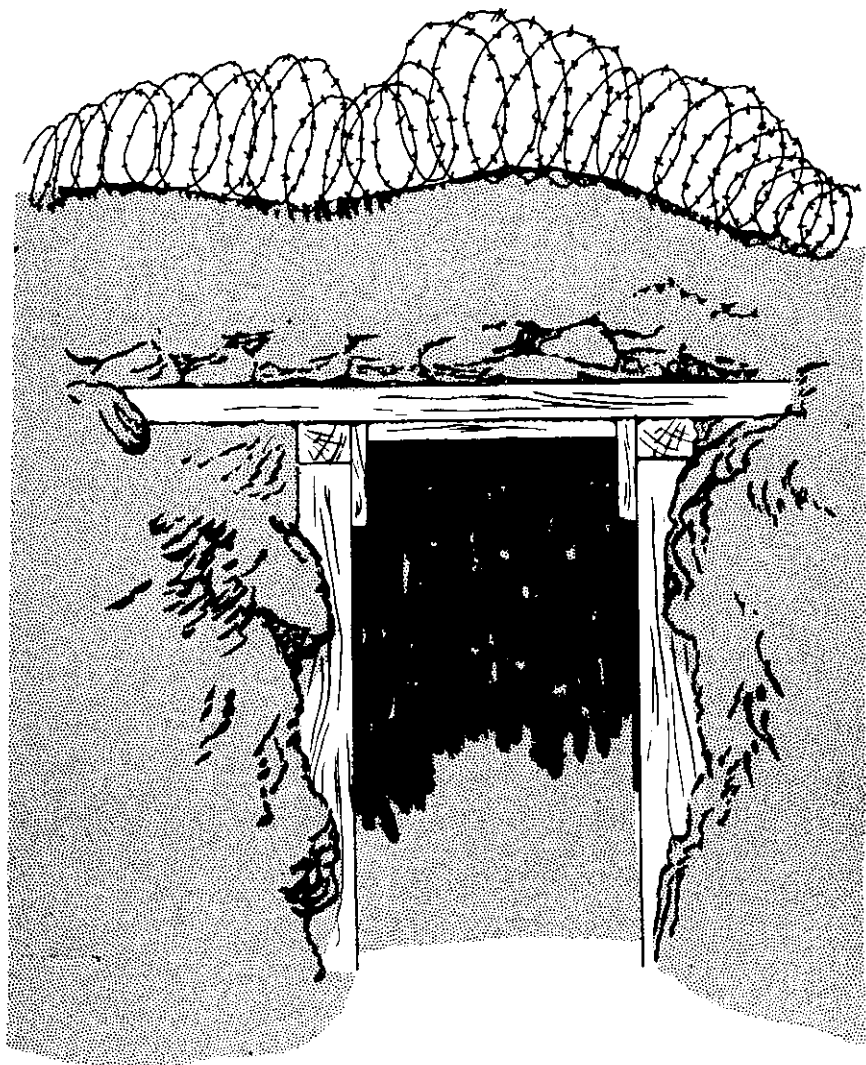

Figure 79. Protective wire installed on top of overhead cover.

(3) *Supplementary.* Supplementary wire entanglements are used to conceal the exact line of the tactical wire and to inclose the entire defensive position by connecting the protective wire that surrounds each platoon. Supplementary wire entanglements used to break up the line of tactical wire should be identical to the tactical wire entanglements and constructed simultaneously with them whenever possible.

b. *Depth.* Entanglements are classified by depth as belts, bands, or zones.

(1) *Belt.* A belt is an entanglement one fence in depth.

- (2) *Band*. A band consists of two or more belts in depth, with no interval between them. The belts may be fences of the same type, or the band may be composed of two or more fences of different types.
- (3) *Zone*. A zone consists of two or more bands or belts in depth, with intervals between them.

c. Equivalent Effectiveness. Entanglement depths are also described or specified in terms of comparative effectiveness. Tactical wire entanglements should be equivalent in effectiveness to 3 belts of 4- and 2-pace double apron fence whenever possible. Protective wire may employ any type of entanglement provided its effectiveness is at least the equivalent of that of the 4- and 2-pace double apron fence. Supplementary wire should have an effectiveness equivalent to that of the type of wire it supplements. It should be equivalent to tactical wire or equivalent to the type of protective wire being used if it connects the outer perimeters of protective wire at the flanks and rear.

d. Portability.

- (1) Fixed entanglements are those types which must be erected in place and which cannot be moved unless completely disassembled.
- (2) Portable entanglements are those types which can be moved without complete disassembly. Portable entanglements have been developed for one of the following reasons:
 - (a) To permit assembly in rear areas, with ease of transportation and rapid installation in forward positions.
 - (b) For the temporary closing of gaps or lanes which can be reopened quickly for patrols or counterattacking forces.

109. Uses

a. In the Defense.

- (1) *Outpost area*. The combat outposts should be surrounded with wire entanglements. These entanglements should be carefully sited to serve as both protective and tactical wire and must be covered by small arms fire. The wire obstacles should be supplemented by antipersonnel mines, warning devices, and boobytraps.
- (2) *Battle position*. In the battle area, each company defense position is normally surrounded by a wire entanglement which is connected laterally across the front to the entanglements surrounding the other units in the position.
- (3) *Artillery and reserve area*. Wire entanglements are used in the outer protection of howitzer positions. Heavier weapons, and shelters or other installations in the reserve area, are similarly protected if justified by the situation.
- (4) *Antipersonnel obstacles*. Barbed wire entanglements, trip flares,

noise makers, and antipersonnel mines are sited to warn against enemy patrol action or infiltration at night; to prevent the enemy from delivering a surprise attack from positions close to the defenders; and to hold, fix or delay the enemy in the most effective killing ground. Such obstacles should be near enough to defensive positions for adequate surveillance by the defenders by night and day and far enough away to prevent the enemy from using hand grenades against the defender from points just beyond the obstacle.

b. As Road Blocks. A series of barbed wire concertinas as shown in figure 80 will stop wheeled vehicles. A series of these blocks placed about 10 yards apart should be used. The ends of adjacent coils are wired together and the obstacle lightly anchored at the sides of the road. The block should be sited to achieve surprise.

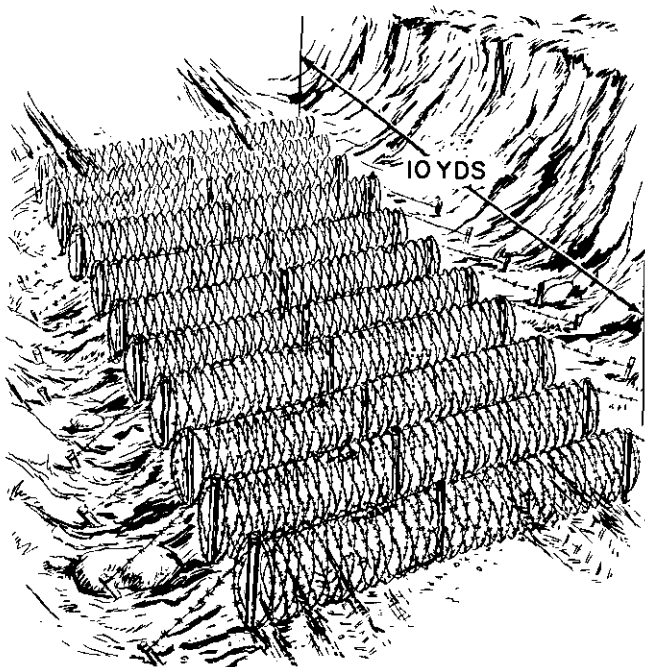

Figure 80. Concertina roadblock.

c. To Strengthen Natural Obstacles. Deep rivers, canals, swamps, and cliffs which form effective delaying obstacles to infantry, and thick hedgerows, fences, and woods, which are only partial obstacles, can be improved by lacing with barbed-wire, by the addition of parts of standard fences on one or both sides, or by entangling with loose wire.

Section IV. ANTIVEHICULAR OBSTACLES

110. General

In defensive positions, antivehicular obstacles are used to obstruct gaps between natural obstacles or in lines of considerable length in open terrain. These obstacles are usually employed in conjunction with wire entanglements, minefields, and other obstacles. Under some conditions they may be continuous in areas just inland of beaches. Antivehicular obstacles should not be continuous across the front of a position, but should have gaps which can be kept under observation and fire and at which flares and other warning devices can be kept in operational condition. Such gaps tend to canalize vehicular movement; they cannot be expected to stop such attacks unless they are exploited by observation and effective covering fire. If enemy forces are equipped with short gap bridging the effectiveness of antivehicular obstacles under 60 feet in width is materially decreased. A narrow ditch will halt a unit so equipped only until this organic bridging can be brought into play.

111. Siting

Antivehicular obstacles are sited to take advantage of trees, brush, or folds in the ground for concealment and surprise effect. If they can be sited to permit flooding with water, the obstacle becomes more effective and helps to deny its use to the enemy as a protected firing position for infantry. In some situations, antivehicular obstacles may also be sited for close-in protection, in front or to the rear of the main line of resistance and as adjuncts to other obstacles. In such locations, vehicles may be separated from their infantry support and are vulnerable to antivehicular weapons.

CHAPTER 14

PRINCIPLES OF EMPLOYMENT OF ARTIFICIAL BEACH AND RIVER LINE OBSTACLES

112. Army Responsibility

In unilateral Army shore-to-shore amphibious operations, army forces are responsible for the installation and removal of beach obstacles. In joint Army-Navy operations, Navy forces are normally responsible for installation and removal of obstacles seaward from the one-fathom line at low tide and Army forces have similar responsibility landward from the same point.

113. Ocean Beach Defenses

An assault across an ocean normally involves a ship-to-shore assault in which the enemy requires adequate anchorages for assault shipping and shore for beaching large landing craft. Where the overwater distance is short, however, or where the enemy can develop a nearby base in neutral or unoccupied territory, shore-to-shore operations are practicable, using smaller craft able to land troops and vehicles at almost any point. Against either of these types of operation, antiboat and antipersonnel obstacles at wading depths are desirable in most situations. Antipersonnel obstacles so located, however, are not effective against large landing craft if the latter can beach at the waterline or can side-carry floating causeways and use them to get ashore.

a. Beach obstacles are designed to force landing craft to unload at low tide several hundred yards seaward of the highwater mark. Thus, on beaches with gradual slopes assaulting infantry must cross a wide expanse of obstacle-studded beach covered by heavy defensive fire before reaching the high-water mark. At high tide, beach and underwater obstacles should be covered by just enough water so that they cannot be seen by personnel in landing craft. When landing craft strike the obstacles they are disabled and the assaulting troops are forced to disembark in deep water.

b. Antiboat obstacles are constructed at varying heights so they are about 1 to 2 feet below the surface of the water at high tide, echeloned in depth in various arrangements of which those shown in figure 81 are typical.

114. River Line Defenses

All possible means of crossing are studied, including assault boats, footbridges, fixed and floating vehicular bridges, and the use or rehabili-

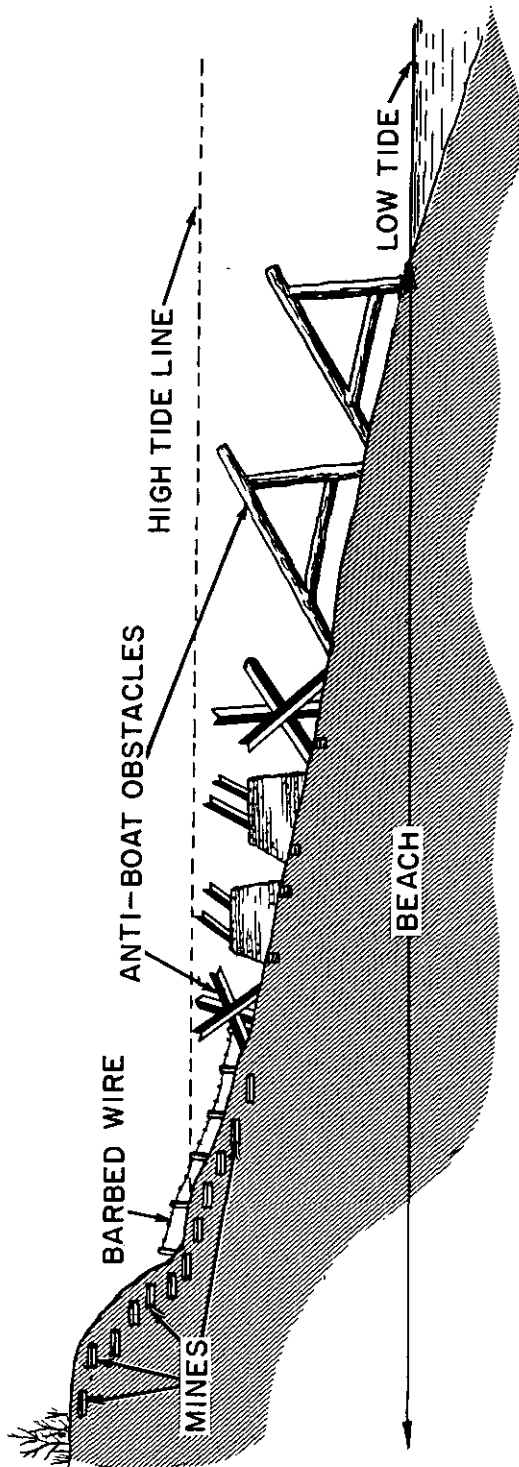

Figure 81. Anti-boat obstacles in beach defense.

tation of existing bridges. In addition to antiboat and antipersonnel obstacles, the defender considers the use of obstacles to hamper the enemy's bridging activities and his installation of booms and other protective devices to protect bridges.

115. General Considerations

a. Siting. The basic requirements for artificial obstacles and their employment apply equally to beach and river-line obstacles. Of particular importance are the requirements that artificial obstacles be used to exploit natural obstacles, that they be inconspicuous, be kept under surveillance, and be capable of being covered by fire. Gaps and lanes are provided and are marked or referenced for the use of friendly troops. The type of antiboat obstacles selected for use should be a type which will be effective against the type of boats which can operate in the surf, current, and wind conditions to be expected. They are sited for maximum obstacle effect at the tide stage at which an assault is probable and for maximum effectiveness against amphibious tracked and wheeled vehicles.

b. Beach Slopes. Due to tide and current action, beaches and river lines tend to fall into two general types—those with steep slopes into deep water, and those with gradually sloping bottoms for a considerable distance offshore. Each type has advantages and disadvantages for the defense. The steep slope prevents debarkation until boats reach the beach, but it renders placing underwater obstacles more difficult. The gentle slope facilitates placing obstacles but it also allows the attacking troops to disembark while still afloat.

- (1) *Steep.* For beaches with steeply sloping bottoms, provision should be made for stopping landing craft offshore in deep water. The obstacles may include mines of various types anchored just below the waterline, floating log booms anchored or tied to shore, which may have mines attached, and heavy chains of wire rope stretched between pile dolphins. Preferably such obstacles should be submerged so as to be out of sight but tide variations may make this impracticable. In such cases a compromise must be made between minimum visibility and maximum practicable effectiveness. Where possible, provision is made for adjusting the height of log booms and the like, to conform with water level fluctuations.
- (2) *Sloping.* For beaches with gradually sloping bottoms, the defense attempts to prevent landing craft from reaching the beach or from reaching water or wading depth for personnel and vehicles. In addition to obstacles of the types described above, in water of wading depth the bottom is covered thoroughly with underwater wire entanglements of all types. Underwater wire entanglements must be anchored in place very

securely to prevent damage from surf or currents and so that both enemy and friendly fire will tend to form tangles rather than to clear lanes. In such entanglements, channels provided for passage of friendly small boats may be closed rapidly by the use of anchored concertinas or weighted spirals.

c. *Employment in Depth.* Beach obstacles are typically established in bands in depth, as follows:

- (1) *Antiboat obstacles.* These are located from wading depth at low tide to wading depth at high tide.
- (2) *Barbed-wire entanglements.* These are placed from wading depth at high tide, inshore across the width of the beach.
- (3) *Antivehicular and antipersonnel obstacles.* These are installed beginning at low waterline and extending inshore across the width of the beach. Mines or other obstacles are normally installed at beach exit.
- (4) *Antivehicular ditches.* These are dug beginning at the inshore edge of the beach, where concealment is possible.
- (5) *Other obstacles.* These are located inshore of the beach area, in the same manner as obstacles for land defense.

CHAPTER 15

PRINCIPLES OF EMPLOYMENT OF NATURAL OBSTACLES

116. Types

Natural obstacles include swampy or inundated areas of adequate width and depth, rivers and streams, deep loose sand, heavily timbered areas, steep banks, slopes and ridges, and climatic conditions.

117. Advantages and Disadvantages

Natural obstacles are improved and exploited as fully as possible because the construction of artificial obstacles is limited, in most situations, by a shortage of time, labor, material, and available transportation. Also, some artificial obstacles are made less effective by nuclear bursts, whereas most natural obstacles are either unaffected by such bursts or are made more effective through contamination. A natural terrain feature such as a small stream, an area of soft ground, or an uphill slope can be a very effective obstacle. Natural obstacles frequently have the advantage of being well concealed and will surprise the enemy. Often they can be improved with a minimum of work to become very effective against tanks and personnel. They can be improved with less effort and materials than a *comparable* artificial obstacle can be built. Such features as heavy woods, steep banks, swampy areas, cliffs, cuts, sharp defiles, bodies of water, or large rocks, are capable of stopping tanks. Although infantry can negotiate many natural obstacles that bar tanks, a combination of artificial obstacles with the natural ones will slow down and harass troops. Deep streams and wide bodies of water can force troops to use auxiliary methods of crossing. Rough terrain tends to canalize movement through valleys which can be easily blocked or along the tops of ridges. Where natural obstacles are present, a study should be made to improve and incorporate these obstacles into the defense. Artificial obstacles such as barbed-wire entanglements and minefields may be employed to extend and connect natural obstacles.

118. Retention of Element of Surprise

The enemy must be considered to have adequate knowledge of the existing terrain conditions and measures for improvement of natural obstacles are most effective if properly concealed or if timed in such a way that the element of surprise is retained.

PART FIVE
OBSTACLE CONSTRUCTION
CHAPTER 16
BARBED WIRE ENTANGLEMENTS

Section I. MATERIALS

119. Standard Barbed Wire

a. Description. Standard barbed wire is 2-strand twisted No. 12 steel wire with 4-point barbs at 4-inch spacing (fig. 82).

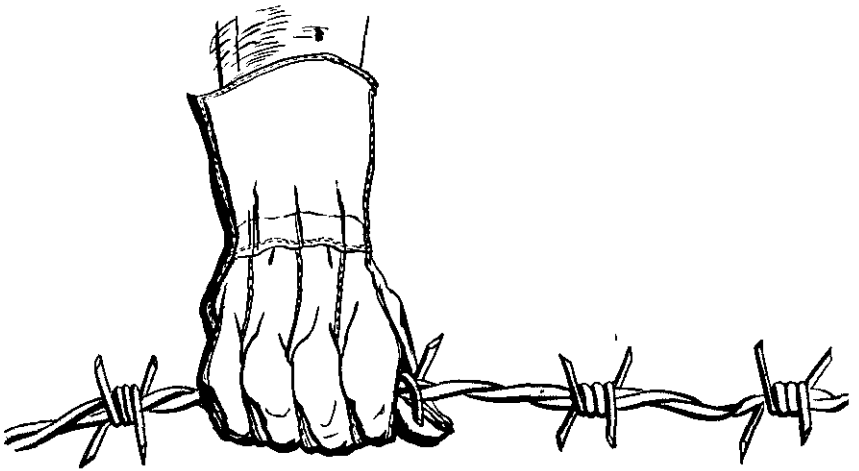

Figure 82. Standard barbed wire.

b. Handling. In handling barbed wire, the standard barbed wire gauntlets shown in figure 82 or heavy leather gloves are worn. They permit faster work and avoid cuts and scratches. As an added safety precaution, the wire should be grasped with the palm down.

c. Issue. Barbed wire is issued in reels (fig. 83) containing about 400 yards of wire. The wire weighs 100 pounds and the reel 5 pounds. In building a fence, 2 men handle 1 reel.

d. Bobbins. Bobbins (fig. 84) holding 30 yards of wire are prepared, normally in rear areas, for use in building short lengths of fence and in repairing entanglements. In use, 2 men handle 1 bobbin. One un-

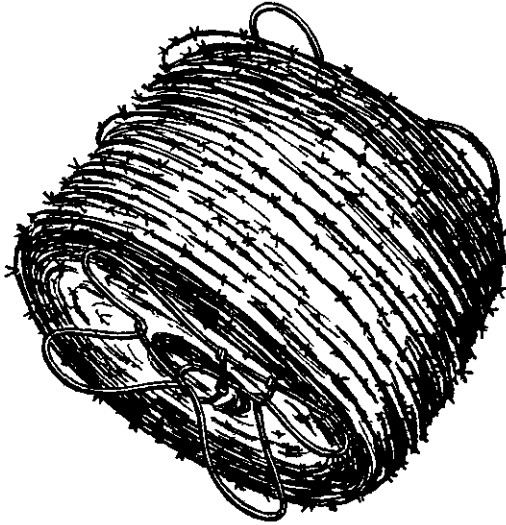
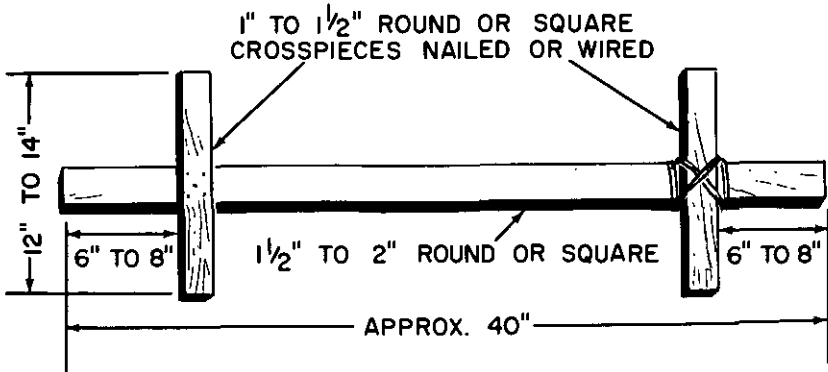

Figure 83. Barbed wire reel.



① METHOD OF MAKING BOBBIN



FREE END MARKED WITH WHITE TAPE

② COMPLETED BOBBIN

Figure 84. Barbed wire bobbin.

winds the bobbin while the other installs the wire. Two or more men may make the bobbins as follows:

- (1) The bobbin sticks are prepared.
- (2) The reel is rigged on an improvised trestle or other support.
- (3) One man unrolls and cuts 30-yard lengths of wire, fastening one end of each to the trestle.
- (4) The wire is wound in figure-of-eight shape on the bobbin sticks.
- (5) A piece of white tracing tape should be tied to the loose end of the wire to facilitate finding it.

120. Standard Barbed Wire Concertina

a. Description. The standard barbed wire concertina (fig. 85) is a commercially manufactured barbed wire obstacle made of a roll of single-strand, high-strength, spring-steel wire with 4-point barbs attached at $2\frac{1}{3}$ -inch spacing. Wires forming the coils are clipped together at intervals so that the concertina opens to a cylindrical shape 50 feet long and 3 feet in diameter. The concertina is easily opened and collapsed and can be used repeatedly because the wire returns to its original shape after a crushing force is applied and then removed. The wire is much harder to cut than standard barbed wire. The concertina weighs 55 pounds.

b. Handling.

- (1) *To open concertina.* The collapsed concertina is tied with plain-wire bindings attached to the quarter points of a coil at 1 end of the concertina. In opening the concertina, these bindings are removed and twisted around the carrying handle for use in retying the concertina when it is again collapsed. Four men open a concertina and extend it to the 50-foot length, with 1 man working at each end and others spaced along its length to insure that it opens and extends evenly. When necessary, 2 men can easily open a concertina by bouncing it on the ground to prevent snagging as they open it.
- (2) *To collapse concertina.* Two men can collapse a concertina in the following manner: First all kinks in coils are removed. Loose clips are tightened or replaced with plain wire. To close the concertina, 1 man stands at each end of it and places a foot at the bottom of the coil and an arm under the top of the coil. The 2 men walk toward each other closing the concertina by feeding the wire over their arms and against their feet. When closed, the concertina is laid flat and compressed with the feet. The concertina is tied with plain wire bindings.
- (3) *To carry concertina.* One man easily carries the collapsed concertina by stepping into it and picking it up by the wire handles attached to the midpoints of an end coil.

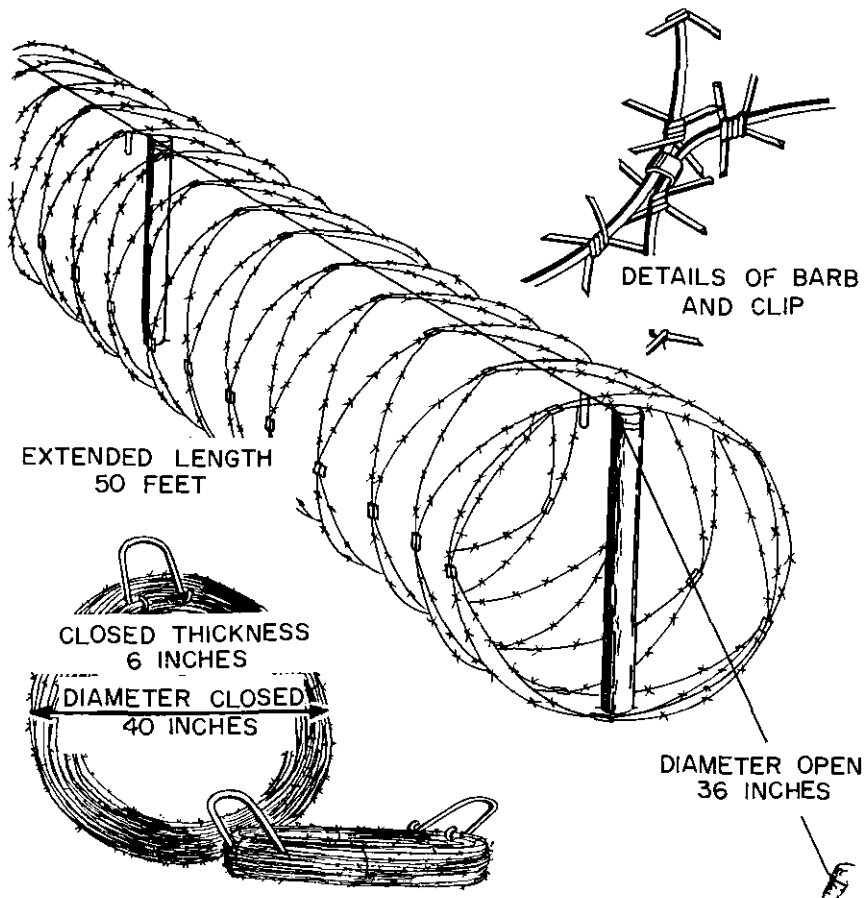

Figure 85. Standard barbed wire concertina.

121. Pickets

Wire entanglements are supported on metal or wooden pickets.

a. Metal Pickets. Metal pickets are issued in two types, screw and U-shaped, and in standard lengths, short or anchor, medium, and long (fig. 86). The U-shaped picket is also issued in an extra-long size. Pickets in serviceable condition are recovered for reuse.

- (1) *Screw picket.* The screw picket is screwed into the ground by turning it in a clockwise direction using a driftpin or another picket inserted in the bottom eye of the picket for leverage. The bottom eye is used in order to avoid twisting the picket. Screw pickets are installed so that the eye is to the right of the picket, as seen from the friendly side. Screw pickets tend to be less rigid than other types but are desirable because they can be installed rapidly and silently. When silence is necessary the driftpin used in installing the pickets should be wrapped with cloth.

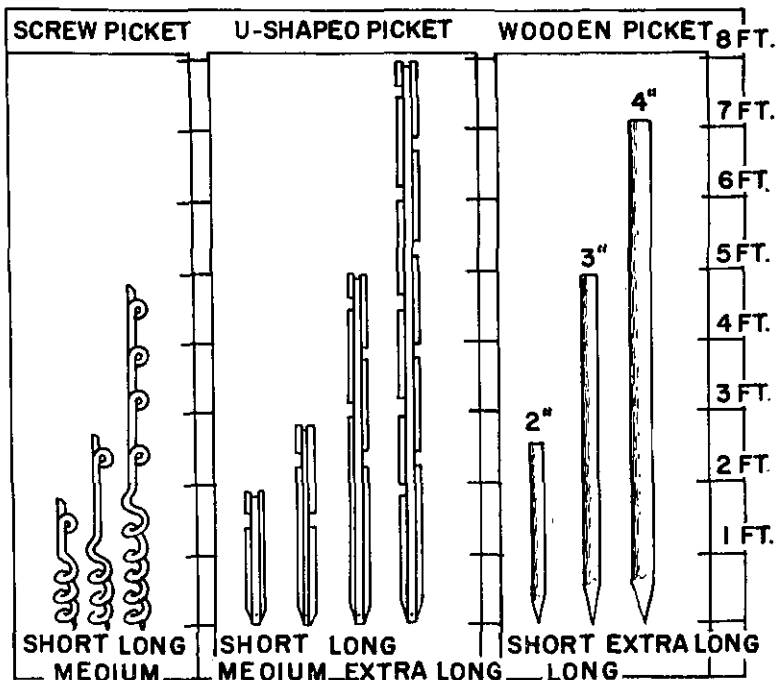

Figure 86. Pickets for use with barbed wire.

- (2) *U-shaped picket.* The U-shaped picket is a cold-formed steel picket of U-shaped cross section, pointed at one end for driving. It is notched for wire ties and the pointed end has a punched hole for wires used in bundling the pickets. U-shaped pickets are driven with a sledge hammer or maul, using a special attachment on top of the picket, to prevent a sledge from deforming it and to avoid splitting the head of a maul. Driving the pickets is noisy and is slower than installing screw pickets; however, noise may be cut down somewhat by placing a piece of rubber tire over the driving face of the maul or sledge. The pickets are rigid and sturdy when properly installed and are preferable to screw pickets in situations where noise is not a disadvantage and time is available. The pickets are driven with the hollow surface or concave side facing enemy fire because small-arms projectiles ricochet from the convex side.
- (3) *Arctic adapter.* For erecting barbed-wire obstacles with U-shaped drive pickets under conditions where frozen ground prevents driving the pickets, an Arctic adapter is available for anchoring the pickets. The adapter is made of steel and consists of a base plate equipped with an adjustable channel receptacle and 2 anchor pins. It is anchored by driving the

anchor pins through holes in the base plate into the ground. One anchor pin drive sleeve with driving pin is provided with each 20 adapters to facilitate anchor pin emplacement.

b. *Wooden Picket.* Expedient wooden pickets of several types may be used.

- (1) Round poles 3 to 4 inches in diameter are cut to standard picket lengths, sharpened on 1 end, and driven with a maul. The pickets are used without peeling the bark, to prevent the wire from sliding on the picket, and to simplify camouflage. Longer pickets are required in loose or sandy soil or when driving through a snow cover. The driving of wooden pickets is not as noisy as the driving of steel pickets, and the noise can be reduced further by fastening a section of tire tread over the face of the hammer or maul. For driving in hard earth, picket tops are wrapped with wire to avoid splitting. Pickets of hardwood, properly installed, are sturdy and rigid.

Table XVIII. Wire Entanglement Materials

| Material | | Weight lb | Length ft | Number carried by 1 man | Weight of man-load lb |
|----------------------------------|------------|--------------|--------------|-------------------------------|-----------------------------|
| Reel | | 105 | 1,200 | ½ | 52.5 |
| Bobbin | | 8-9 | 90 | 4-6 | 32-54 |
| Standard barbed-wire concertina | | 55 | 50 | 1 | 55 |
| Expedient barbed-wire concertina | | 30 | 20 | 1 | 30 |
| Screw pickets | Long | 9 | 4½ | 4 | 36 |
| | Medium | 6 | 2¾ | 6 | 36 |
| | Short | 4 | 1¾ | 8 | 32 |
| U-shaped pickets | Extra long | 16 | 8 | 3-4 | 48-64 |
| | Long | 10 | 5 | 4 | 40 |
| | Medium | 6 | 2¾ | 6 | 36 |
| | Short | 4 | 2 | 8 | 32 |
| Wooden pickets | Extra long | 17-23 | 7 | 2 | 34-46 |
| | Long | 12-16 | 5 | 3 | 36-48 |
| | Short | 3-6 | 2½ | 8 | 24-48 |

- (2) Dimension lumber ripped to a square cross section may be used instead of round poles and is equally satisfactory except that it is more difficult to camouflage. Such pickets may be dipped in camouflage paint prior to driving.
- (3) Standing trees and stumps may be used as pickets when their location permits.

122. Staples

Improvised staples made of 1/2-inch round driftpins or similar material are used to fasten the bottoms of concertina fences securely to the ground.

123. Use of Table

Table XVIII gives a recapitulation of the information on materials used in the construction of barbed wire entanglements.

Section II. CONSTRUCTION PROCEDURES

124. General

Table XIX gives the materials and man-hours required for entanglements of the various types. The normal sizes of work crews are given below in the descriptions of the entanglements. For each construction project, the senior noncommissioned officer divides his crew into groups of approximately equal size, based on his knowledge of the skill and speed of each man. He organizes them in such a way that construction proceeds in proper order and at a uniform rate. Each individual must know exactly what his group is to do and his job in the group. Each man should have barbed wire gauntlets. The sequence of operations for each fence is given below in the paragraph describing the erection of the fence. This sequence should be followed, and as experience is gained, the size and composition of the groups may be varied in the interests of speed and efficiency. For each section of entanglement, all fence-building operations normally proceed from right to left, as one faces the enemy. It may, however, be necessary to work from left to right, and men should, if time permits, be taught to work in either direction. The senior commissioned or noncommissioned officer will decide, in the event of heavy casualties, what wires, if any, are to be omitted.

a. Construction at Night. For night construction the following additional preparations are made:

- (1) Tracing tape should be laid from the materials dump to the site of work and then along the line of fence where possible.
- (2) Materials should be tied together in man loads and pickets bundled tightly to prevent rattling.
- (3) Wire fastenings of wire coils and pickets should be removed and replaced with string which can easily be broken.

Table XIX. Material and Labor Requirements for 300-yd Sections Various Barbed-Wire Entanglements

| Type of entanglement | Pickets | | | Barbed wire 400 yd 105 lb reels ¹ | Number of concertinas | Staples | Lbs of materials per lin yd of entanglement ² | Man-hours to erect 300 yds of entanglement ³ |
|---------------------------------------|------------|------|--------|--|-----------------------|---------|--|---|
| | Extra long | Long | Medium | | | | | |
| Double-apron, 4- and 2-pace..... | | 91 | | 12-13 | | | 10 | 54 |
| Double-apron, 6- and 3-pace..... | | 61 | | 11-12 | | | 7 | 45 |
| High wire (less guy wires)..... | | 181 | | 15-18 | | | 12 | 72 |
| Low wire, 4- and 2-pace..... | | | 91 | 9 | | | 7.5 | 45 |
| Four strand fence..... | | 91 | | 3½-4 | | | 4 | 18 |
| Double-belt expedient concertina..... | | 92 | | 2 | 90 ⁴ | 270 | 14 | 36 |
| Triple-belt expedient concertina..... | 46 | 92 | | 3 | 135 ⁴ | 270 | 21 | 90 |
| Triple-belt standard concertina..... | | 146 | | 2 | 54 | 290 | 16 | 27 |

¹ Lower number of reels applies when screw pickets are used; high number when U-shaped pickets are used. Add difference between the two to the higher number when wood pickets are used.

² Average weight when any issue metal pickets are used.

³ With the exception of the triple-belt concertinas, man-hours are based on the use of screw pickets. When driven pickets are used, add 20 percent to man-hours. With experienced troops, reduce man-hours by ¼. Increase man-hours by 50 percent for night work.

⁴ Based on concertina being made up in rear areas and ready for issue. One expedient concertina opens to 20-foot length, as compared with 50 feet for a standard concertina, and requires 100 yards of standard barbed wire, also small quantities of No. 10 and No. 16 smooth wire for ties.

- (4) A piece of tape should be tied to the ends of the wire on each reel or bobbin.

b. *Supervision.* Proper supervision of entanglement construction includes the following:

- (1) Proper organization of the work into tasks.
- (2) Making sure the tasks are carried out in the proper sequence.
- (3) Prevention of bunching and overcrowding of personnel.
- (4) Making sure the wires are tightened properly and spaced correctly.
- (5) Checking ties to see that they are being made correctly and at the right points.

c. *Construction in Combat Areas.* When working in close proximity to the enemy, the necessary precautions include—

- (1) The provision of security around the work party.
- (2) Silence.
- (3) No working on enemy side of fence unless absolutely necessary.
- (4) The use of screw pickets, if available.
- (5) Men not working should lie down near start of work until they can continue their work.
- (6) Individual weapons must be kept nearby at all times.

d. *Wire Ties.* Wires are tied to pickets by men working from the friendly side of the wire and picket, stretching the wire with the right hand as the tie is started. The four ties used in erecting wire entanglements are shown in figure 87.

- (1) *Top-eye tie.* The top-eye tie is used to fasten wire to the top eye of screw pickets. It is made in one continuous movement of the left hand (fig. 88) while the right hand exerts a pull on the fixed end of the wire. This is a secure tie, is quickly made, and uses only a few inches of wire.
- (2) *Intermediate-eye tie.* This tie is used to fasten wire to eyes other than the top eye, in screw pickets. It is made as shown in figure 89. This tie and the other ties described below require more time to make than the top-eye tie and each uses several feet of wire. In making the intermediate-eye tie shown in figure 89, the following points are especially important:
 - (a) The right hand reaches over the fixed wire and around the picket, with the palm down. The left hand holds the fixed end for tension.
 - (b) The loops are removed from the free end and wrapped around the picket.
 - (c) One side of the loop should pass above the eye and the other side below the eye.
- (3) *Post tie.* Wire is fastened to wooden pickets or to the steel U-shaped picket with the post tie shown in figure 90. The

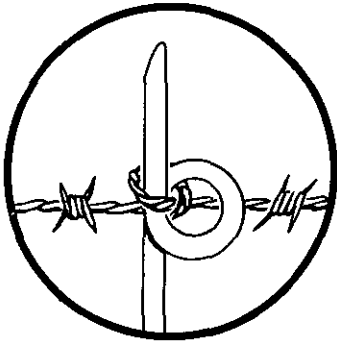

TOP-EYE TIE

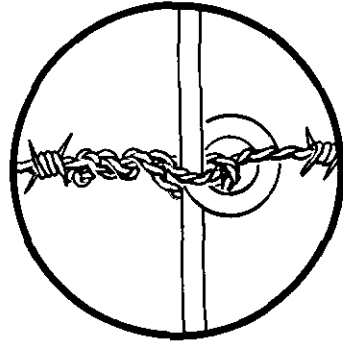

INTERMEDIATE-EYE TIE

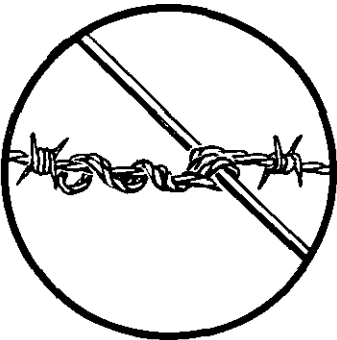

APRON TIE

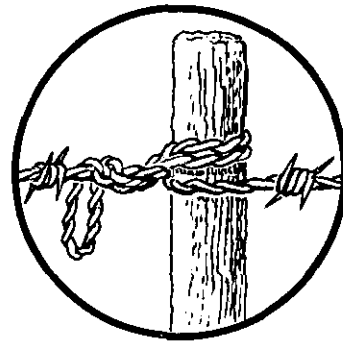

POST TIE

Figure 87. Ties used in erecting wire entanglements as seen from friendly side.

wire should be wrapped tightly around the post to keep the barbs from sliding down the post. With the U-shaped picket, the wire wrapping is engaged in a notch in the picket. The method is essentially the same as that of the intermediate-eye tie.

- (4) *Apron tie.* The apron tie is used whenever two wires that cross must be tied together. It is made as shown in figure 91. It is the same as the post tie except that a wire is substituted for the post.

e. Method of Installing Wires

- (1) The end of the wire is attached to the first anchor picket. This is the picket at the right end of a section of entanglement, from the friendly side. Fences are built from right to left as this makes it easier for a right-handed man to make the ties while remaining faced toward the enemy.

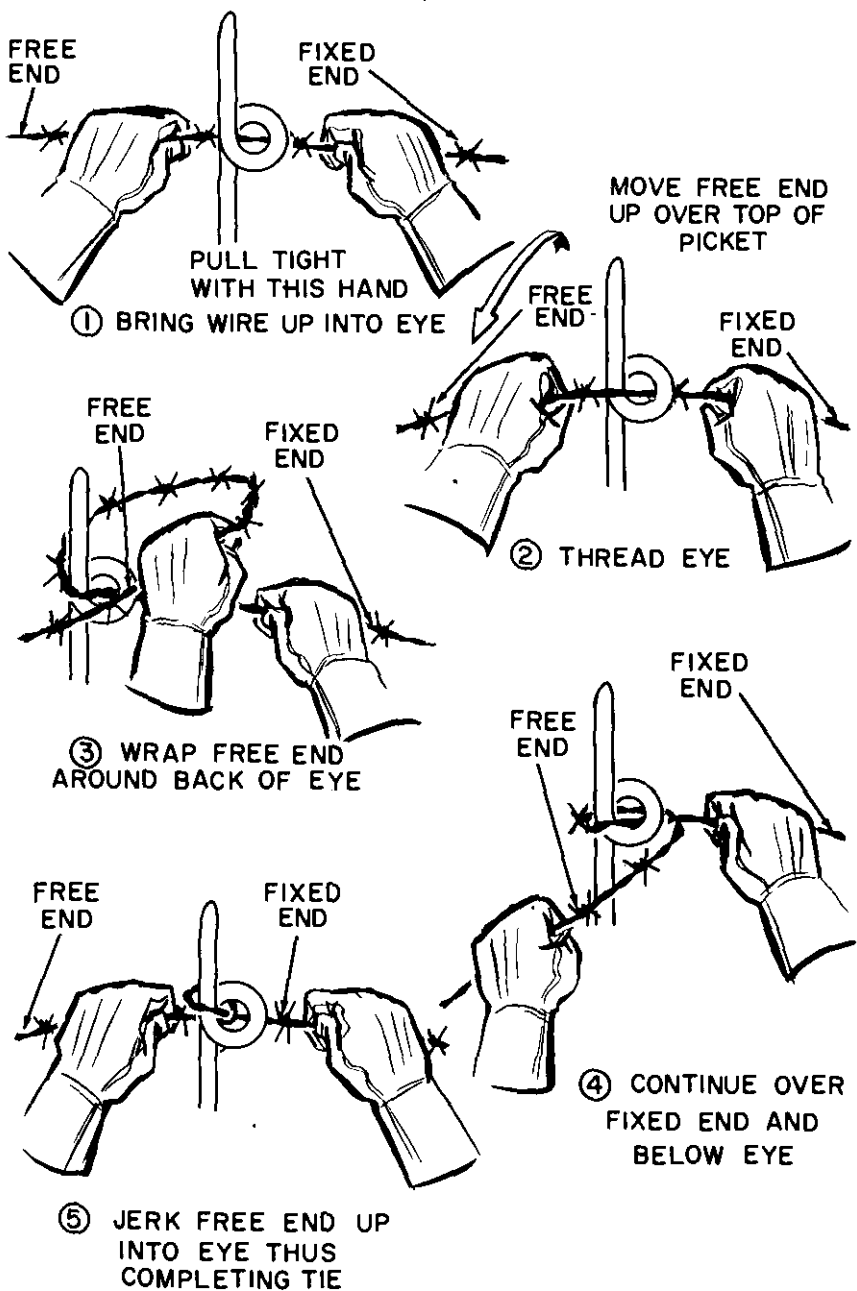
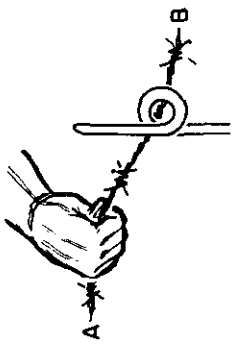

Figure 88. Top-eye tie.



① WITH PALM DOWN REACH AROUND PICKET OVER FIXED END AND TAKE LOOP FROM FREE END



② PULL LOOP BACK AROUND PICKET

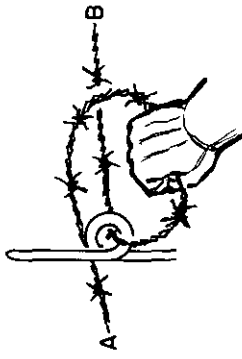

③ BRING LOOP FORWARD AND DOWN OVER FIXED END END OF LOOP GOES BEHIND EYE, THUS LOOP SPLITS EYES

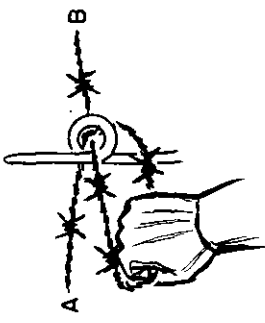

④ CONTINUE LOOP DOWN (AND ACROSS TO FREE END)



⑤ BRING LOOP UP OVER FREE END

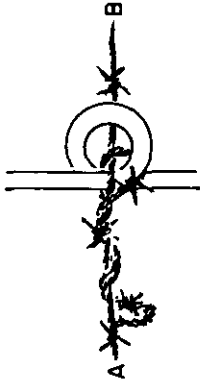

⑥ WIND LOOP AROUND FREE END AT LEAST TWO TURNS TO COMPLETE FASTENING
A = FREE END B = FIXED END

Figure 89. Intermediate-eye tie.

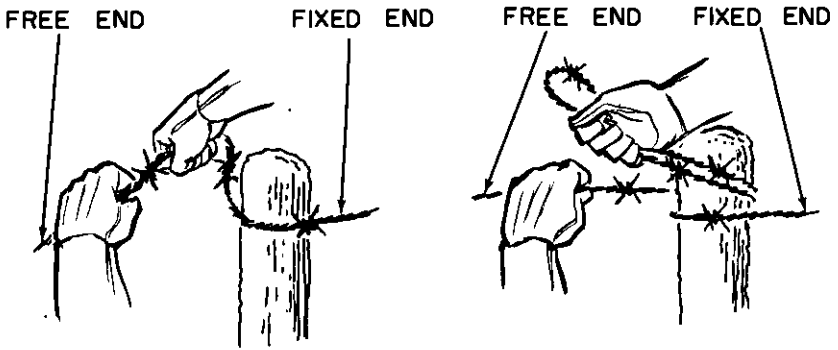

① WITH PALM DOWN REACH AROUND PICKET OR POST OVER FIXED END AND TAKE LOOP FROM FREE END

② WRAP LOOP AROUND POST ABOVE FIXED END

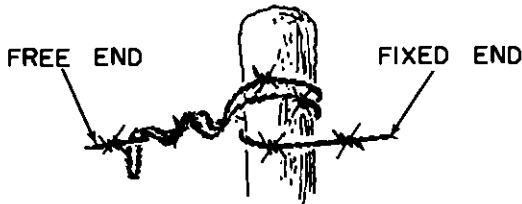

③ WRAP LOOP AROUND FREE END AT LEAST TWO TURNS TO COMPLETE TIE

Figure 90. Post tie.

- (2) A bar is inserted in the reel and the reel is carried for 25 to 30 yards allowing the wire to unreel from the bottom. This is done on the friendly side of the row of pickets to which the wire is to be tied.
- (3) Slack is put in the wire by moving back toward the starting point; the ties are then made by two men leapfrogging each other. If available, two men can be assigned to make the ties as the reel is unwound.

f. Tightening Wire. After a wire is installed it can be tightened, if necessary, by racking with a driftpin or short stick (fig. 92). Wires should not be racked at ties or where they intersect other wires because this makes salvage of the wire very difficult. Fences are similarly racked to tighten them when they sag after having been installed

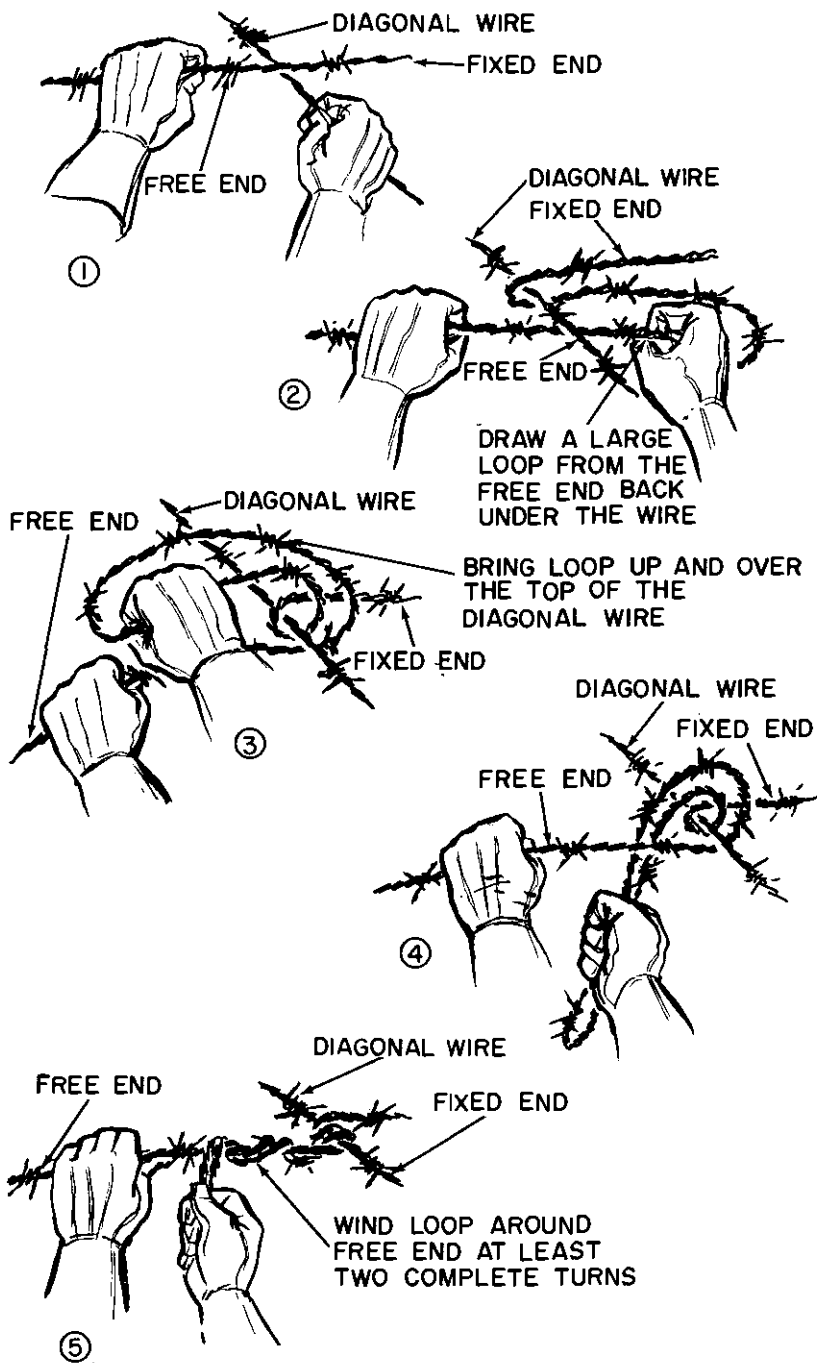

Figure 91. Apron tie.

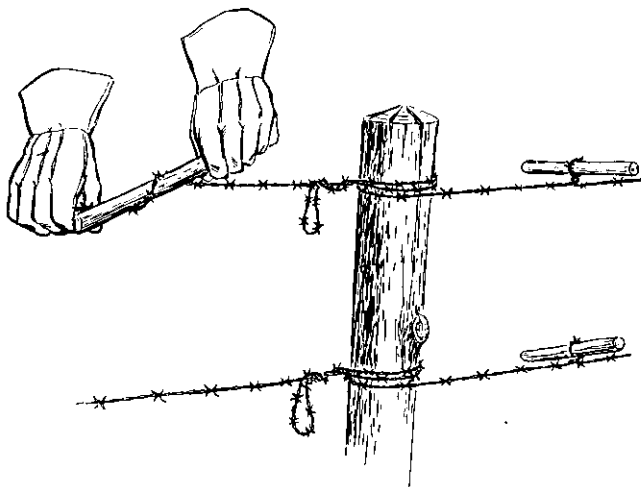

Figure 92. Tightening wire by racking.

for some time. Wires should be just taut enough to prevent them from being easily depressed by boards, mats, or similar objects thrown across them. If wires are stretched too tightly they are more easily cut by fragments.

125. Double-Apron Fence

a. General. There are 2 types of double-apron fence: the 4- and 2-pace fence and the 6- and 3-pace fence. The 4- and 2-pace fence (fig. 93) is the better obstacle of the two and is the type more commonly used. In this fence the center pickets are 4 paces apart and the anchor pickets are 2 paces from the line of the center pickets and opposite the midpoint of the space between center pickets. The 6- and 3-pace fence follows the same pattern with pickets at 6- and 3-pace intervals. For this fence less material and construction time are required, but the obstacle effect is substantially reduced because with the longer wire spans it is easier to raise the lower wires and crawl over or under them. Except for picket spacing the 4- and 2-pace and then 6- and 4-pace fences are identical. Only the 4- and 2-pace fence is discussed in detail.

b. Construction. A 300-yard section of either type of double-apron fence is a platoon task normally requiring 1½ hours, assuming 36 productive men per platoon. There are 2 operations in building a double-apron fence: laying out and installing pickets and installing wire. The first operation is nearly completed prior to starting the second. The second operation is started as men become available and the first operation has moved far enough ahead to avoid congestion. A platoon is normally assigned to build a 300-yard section.

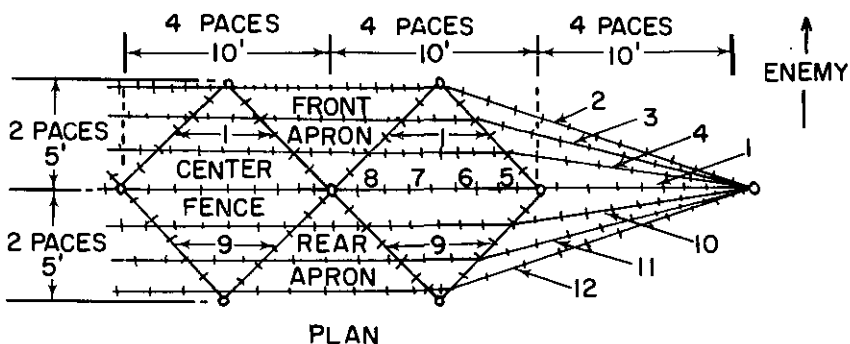

NOTE:
EYES OF ALL PICKETS POINT
IN DIRECTION FROM WHICH
FENCE IS BEING ERECTED.

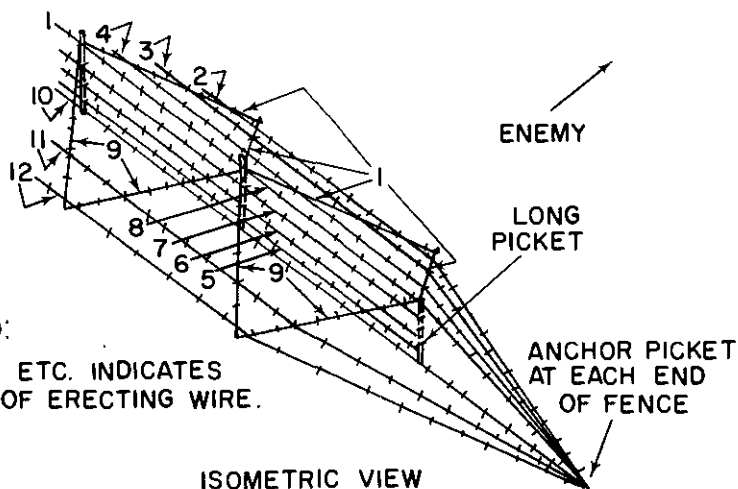
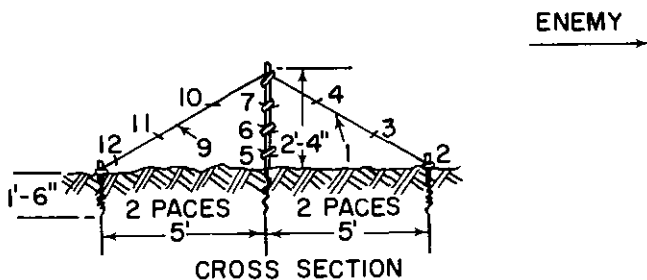

LEGEND:
1-2-3-4 ETC. INDICATES
ORDER OF ERECTING WIRE.

Figure 98. Double-apron fence.

- (1) *First operation.* The working party, if not organized in 3 squads, is divided into 3 groups of approximately equal size. One squad lays out the long pickets along the centerline of the fence at 4-pace intervals (10 feet), at the spot where they are to be installed and with their points toward the enemy. Another squad lays out the anchor pickets, with points toward the enemy and positioned 2 paces (5 feet) each way from the centerline and midway between the long pickets (fig. 94). The 5-foot spacing is readily checked with a long picket. The third squad installs all the pickets, with the help of the two other squads as the latter finish the work of laying out the pickets. When installed the lower notch or bottom eye of the long pickets should be approximately 4 inches off the ground to make passage difficult either over or under the bottom wires.

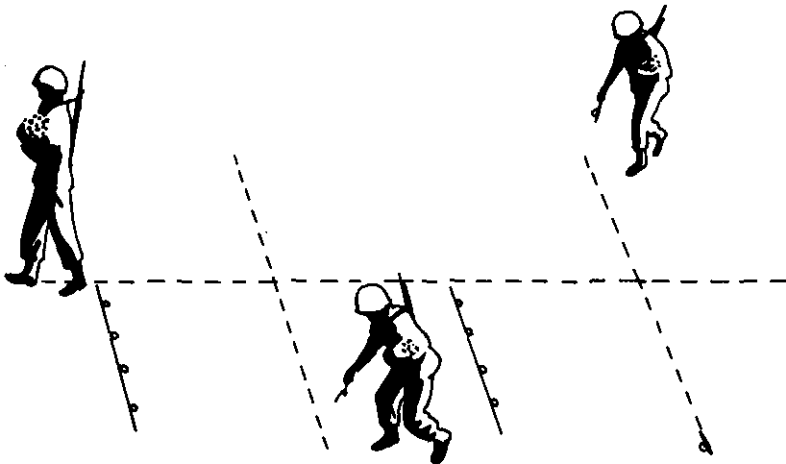

Figure 94. Laying out anchor pickets.

- (2) *Second operation.* As the groups complete the first operation, they return to the head of the fence and begin installing wire. The order in which the wires are installed is shown in figure 93 and is further illustrated in figure 95. Care must be taken to avoid having any of the men cut off between the fence and the enemy. The men are divided into 2- or 4-man groups and proceed to install the wires in numerical order; that is, as soon as the men installing one wire have moved away from the beginning of the fence and are out of the way, the next wire is started. Installation is as follows:

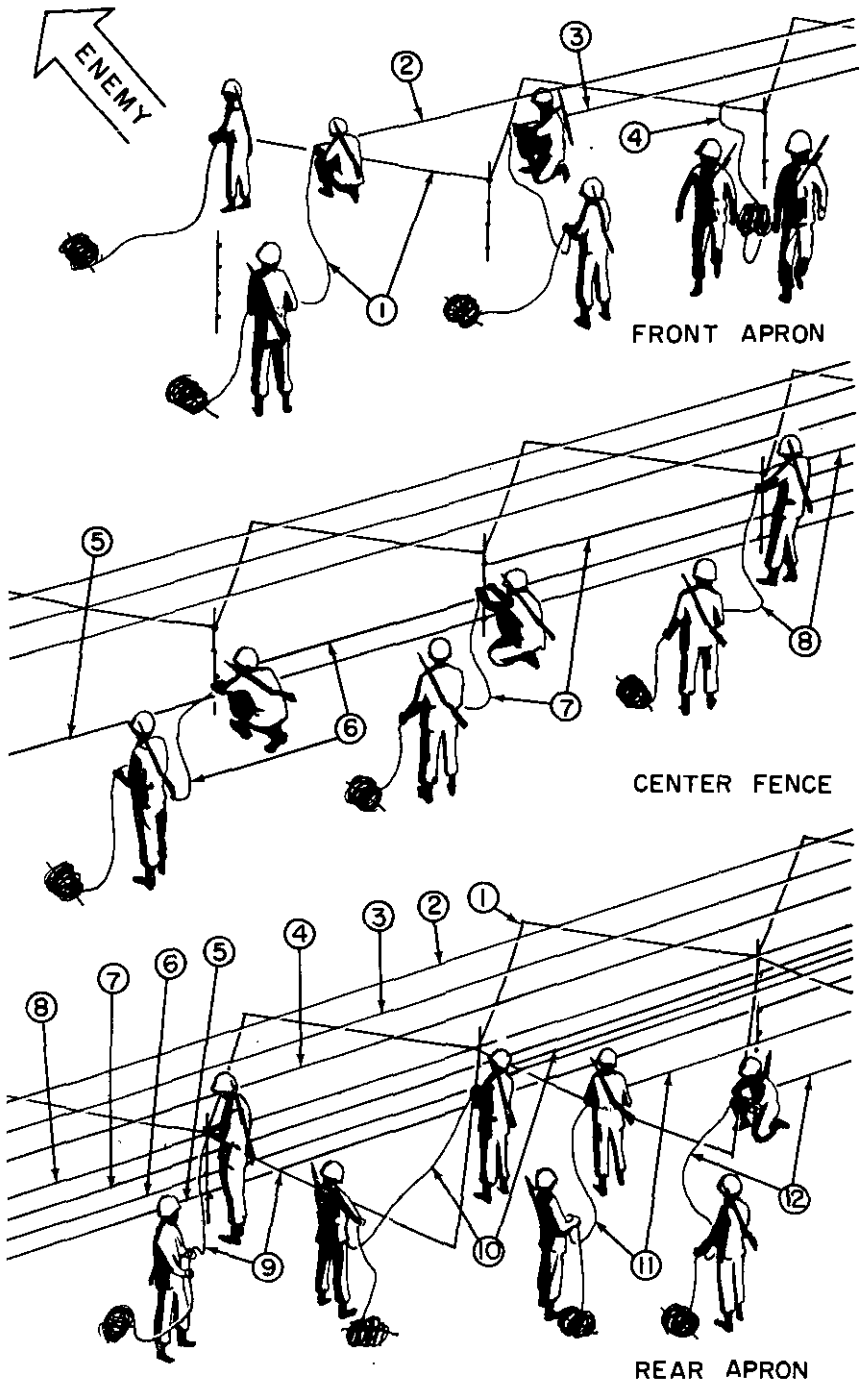
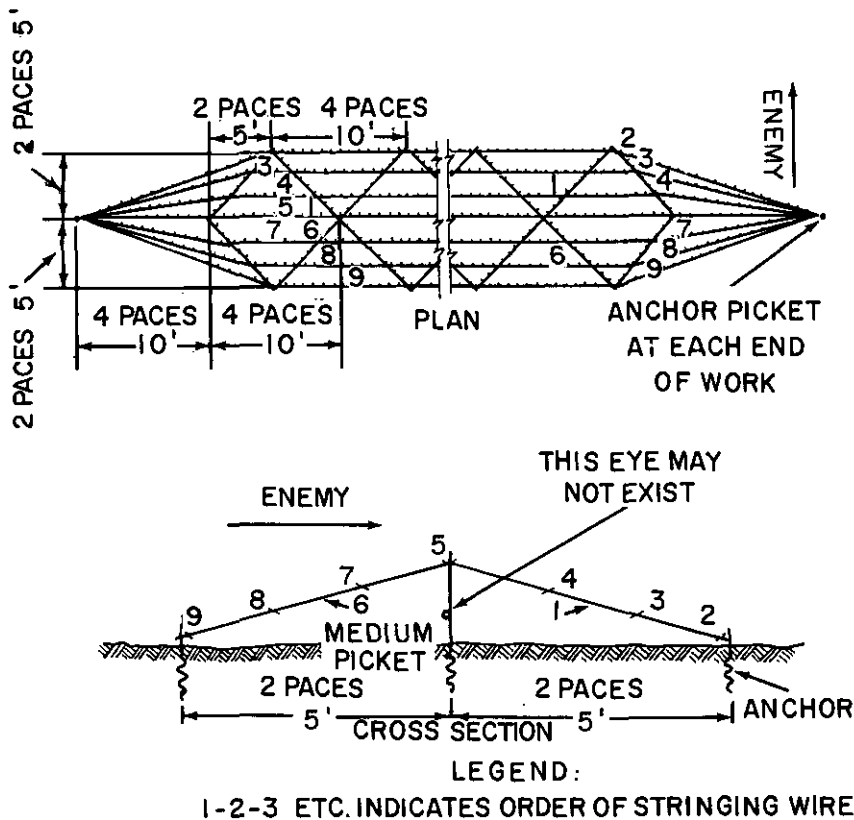

Figure 95. Sequence of installing wire in a double-apron fence.

- (a) The No. 1 wire is the diagonal wire on the enemy side and is secured with a top-eye tie to all pickets. It is important to keep this wire as tight as possible.
- (b) The No. 2 wire is the trip wire on the enemy side of the fence and is secured to both diagonals just above the anchor picket with the apron tie. This wire must be tight enough and close enough to the ground to make passage over or under the wire difficult.
- (c) The No. 3 wire is an apron wire on the enemy side of fence. It is secured to the first diagonal wire, and thereafter to each alternate diagonal, and then to the last diagonal wire. The No. 4 wire is also an apron wire on the enemy side of the fence. It is secured to the first diagonal wire (No. 1), thereafter to the diagonal wires which are not tied to the No. 3 wire and then to the last diagonal wire. Apron wires Nos. 3 and 4 are equally spaced along the diagonal wire.
- (d) The No. 5 wire is the first one which is not started from the end anchor picket. It is started at the first long picket. It is secured with the intermediate-eye tie and is stretched tightly to prevent passage over or under it.
- (e) Wires Nos. 6, 7, and 8 complete the center portion of the fence and are secured to the long pickets, Nos. 6 and 7 with the intermediate-eye tie. No. 8 is secured with the top-eye tie. These wires (Nos. 6, 7 and 8) form the backbone of the fence and are drawn up as tightly as possible to hold the pickets in position.
- (f) No. 9 is the diagonal apron wire on the friendly side of the fence and is secured with the top-eye tie to all pickets. Nos. 10 and 11 are apron wires and No. 12 is the trip-wire on the friendly side of the fence. Wire No. 12 is installed in the same manner as wire No. 2 (b) above.
- (g) If the fence is not satisfactorily tight when installed, wires are tightened by racking as described in paragraph 124f.

126. Low Wire Fence

a. General. This is a 4- and 2-pace double-apron fence in which medium pickets replace long pickets in the fence centerline (fig. 96). This results in omission of the Nos. 6 and 7 wires, and in bringing all the apron and diagonal wires much closer to the ground so that passage underneath this fence is difficult. If wire obstacles in bands or zones are authorized, this fence may be used advantageously on one or both sides of the double-apron fence. The low wire entanglement is used where concealment is essential. In tall grass or shallow water, this entanglement is almost invisible and is particularly effective as a surprise obstacle. However, a man can pick his way through this low wire



NOTE:
EYES POINT IN DIRECTION FROM WHICH FENCE IS BEING ERECTED

Figure 96. Low wire fence.

fence without much difficulty; therefore, for best results it must be employed in depth.

b. Construction. Except for the omission of the two wires and the substitution of the medium pickets, this fence is constructed in the same manner as the double-apron fence (par. 125).

127. Four-Strand Cattle Fence

a. General. The four-strand center section of a double-apron fence can be installed rapidly to obtain some obstacle effect, and aprons can be added later to develop it into a double-apron fence. In country where wire fences are used by farmers, obstacles in the form of four-strand cattle fences (fig. 97) will blend with the landscape. Their design should follow as closely as possible the local custom, usually

wooden pickets at about 2- to 4-pace intervals with 4 horizontal strands of barbed wire fixed to them. They should be sited along footpaths and edges of fields or crops, where they will not look out of place. If conditions permit, this fence may be improved by installing guy wires in the same manner as the diagonal wires of the double-apron fence. Table XX does not include materials for these guy or diagonal wires, therefore they must be added separately when estimating. All longitudinal wires of this fence must start and end at an anchor picket.

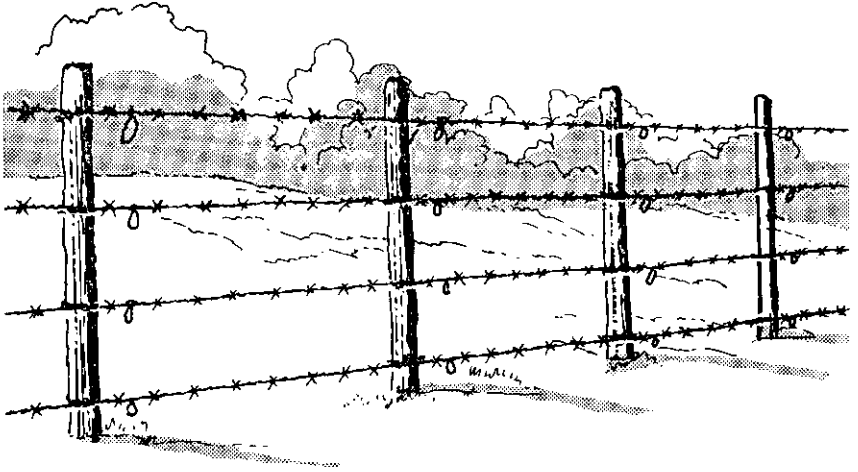

Figure 97. Four-strand cattle fence.

b. Construction. Eight men may be employed on short sections of this fence and up to 16 on 300-yard sections. The 2 operations are laying out and installing pickets and installing wire.

- (1) *First operation.* The working party is divided into 2 groups of approximately equal size. The first group carries and lays out long pickets at 10-foot intervals along the centerline of the fence, beginning and ending the section with an anchor picket and including anchor pickets for guys if needed. The second group installs the pickets.
- (2) *Second operation.* As the first task is completed, men move individually to the head of the fence and are organized into teams of 2 or 4 men to install wires. For 4-man teams, 2 men carry the reel and 2 men make ties and pull the wire tight. For 2-man teams, the wire must first be unrolled for 50 to 100 yards then the men come back to the head of the work and make the ties, or the wire may first be made up into bobbins to be carried and unwound by one man while the other man makes the ties. The first team installs the bottom fence wire, drawing it tight and close to the ground. Succeeding teams install the next wires in order.

128. High-Wire Entanglement

a. *General.* This obstacle consists of 2 parallel 4-strand fences with a third 4-strand fence zigzagged between them to form triangular cells. With 2 rows of pickets as shown in figure 98, the entanglement is classed as a belt; with one or more additional rows of fences and triangular cells it is a band. To add to the obstacle effect, front and rear aprons

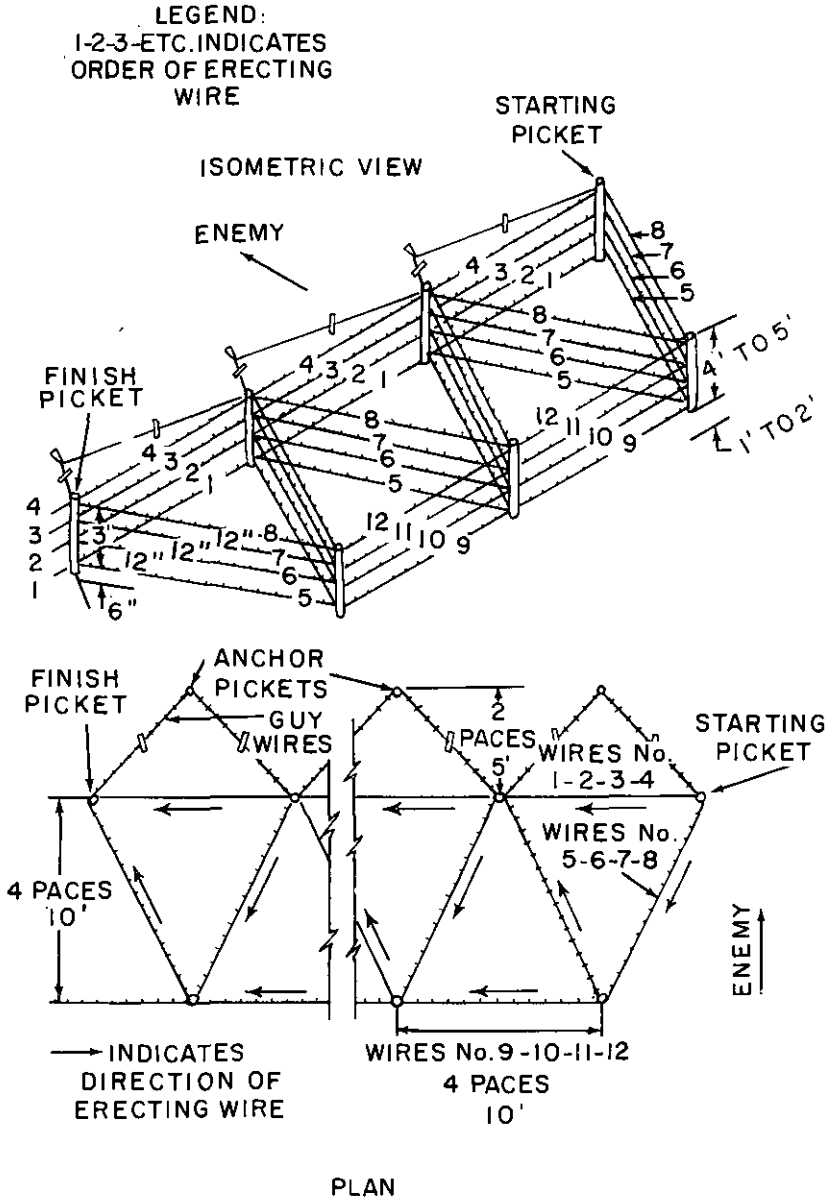

Figure 98. High-wire entanglement.

may be installed and spirals of loose wire may be placed in the triangular cells.

b. Construction. A 300-yard section of high-wire entanglement with 2 rows of pickets, as shown in figure 121, is a platoon task normally requiring 2 hours, assuming 36 productive men per platoon. The 2 operations are—laying out and installing pickets, and installing wire.

(1) *First operation.* For this operation the working party is divided into 2 groups, assigning $\frac{2}{3}$ of the men to the first group and $\frac{1}{3}$ to the second. The first group carries and lays out pickets, front row first and at 10-foot intervals. Second-row pickets are laid out in a line 10 feet to the rear of the front row and spaced midway between them. The group also lays out an anchor picket in line with each end of each 4-strand fence, 10 feet from the nearest long picket. If guys are needed, anchor pickets are also laid out in lines 2 paces from the lines of the front and rear fences, opposite and midpoint of spaces between the long pickets. The second group installs front-row pickets, returns to the head of the fence and installs the rear row and then installs the anchor pickets. When the first group finishes laying out pickets they begin installing wire and help finish installing the pickets.

(2) *Second operation.* As the first task is completed, men move individually to the head of the fence and are organized into teams of 2 or 4 men to install wires in the same manner as for the 4-strand fence. The order of installation is as shown in figure 121, except that if front guys are used they are installed before the No. 1 wire; rear guys after the No. 12 wire. The lengthwise wires of each 4-strand fence begin and end at an anchor picket.

129. Standard Concertina Fences

The standard concertina is described in paragraph 120, and the advantages of the concertina type obstacles are given in paragraph 109. As an obstacle, in most situations the triple standard-concertina fence is better than the double-apron fence. The material for it weighs about 50 percent more but it is erected with about $\frac{1}{2}$ the man-hours. Every concertina fence is secured firmly to the ground by driving staples (par. 122) at intervals of not more than 2 yards. The staples are used on the single concertina fence and on the front concertina of the double and triple types. The 3 types of fence are as follows:

a. Single Concertina. This is one line of concertinas. It is erected quickly and easily but is not an effective obstacle in itself. It is used as an emergency entanglement or for the temporary closing of gaps between other obstacles. It is for such purposes that one roll of concertina may be habitually carried on the front of each vehicle in engineer combat units.

b. *Double Concertina*. This consists of a double line of concertinas with no interval between lines. The two lines are installed with staggered joints. As an obstacle, the double concertina is less effective than a well-emplaced, double-apron fence. It is used in some situations to supplement other obstacles in a band or zone.

c. *Triple Concertina*. This consists of two line of concertinas serving as a base, with a third line resting on top, as shown in figure 99. All lines are installed with staggered joints. Each line is completed before the next is started so that a partially completed concertina entanglement presents some obstruction. It is erected quickly, and is difficult to cross, cut, or crawl through.

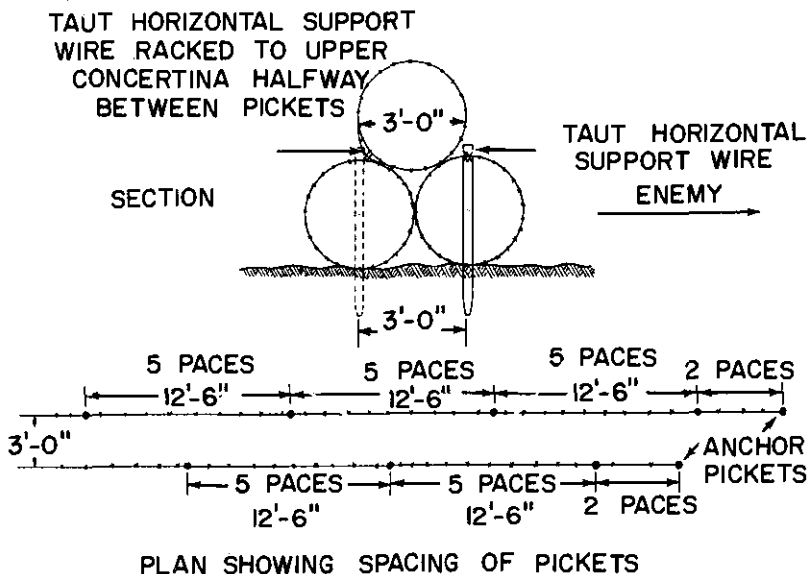

Figure 99. Triple standard-concertina fence.

130. Triple Standard-Concertina Fence

A 300-yard section of this fence is a platoon task normally requiring less than 1 hour. There are 2 operations: carrying and laying out pickets and concertina rolls and installing pickets and opening and installing concertinas.

a. *First Operation*. For the first operation, the working party is divided into 3 groups of approximately equal size: 1 to lay out all pickets, 1 to install all pickets, and 1 to lay out all concertina rolls.

- (1) The first group lays out front-row long pickets at 12½ foot intervals on the line of fence (fig. 100) with points of pickets on line and pointing toward the enemy. The rear row long pickets are then laid out on a line 3 feet to the rear and opposite the center of interval between the front row long pickets. An anchor picket is laid out at each end of each line, 5 feet from the end long picket.

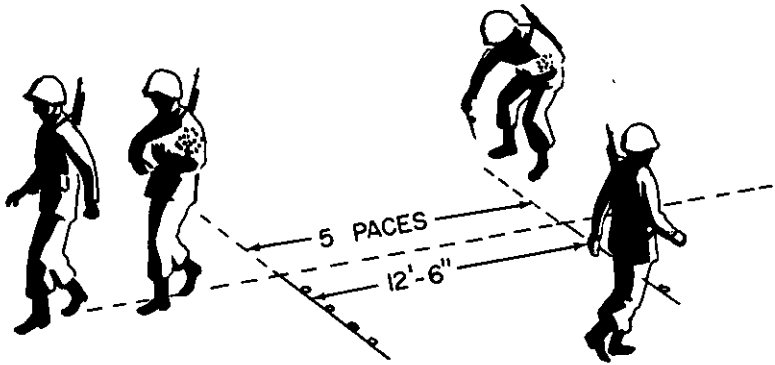

Figure 100. Laying out long pickets for triple concertina fence.

- (2) The second group installs pickets beginning with the front row (fig. 101). As in other fences, eyes of screw pickets are to the right. Concave faces of U-shaped pickets are toward the enemy.

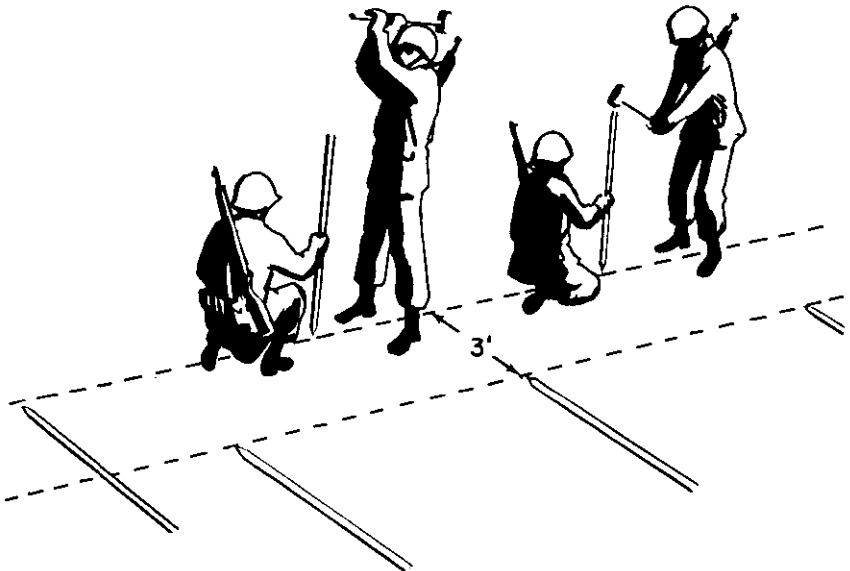

Figure 101. Installing front-row pickets for triple concertina fence.

- (3) The third group lays out concertinas along the rows of pickets (fig. 102). In the front row, 1 roll is placed at the third picket and 1 at every fourth picket thereafter. Sixteen staples accompany each front-row concertina. In the second row, 2 rolls are placed at the third picket and 2 at every fourth picket thereafter. As each roll is placed in position, its binding wires are unfastened but are left attached to the hoop at one end of the roll.

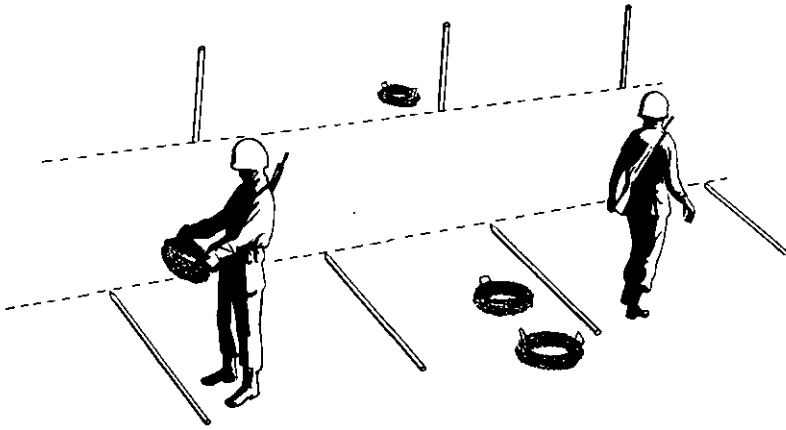

Figure 102. Layout out concertinas.

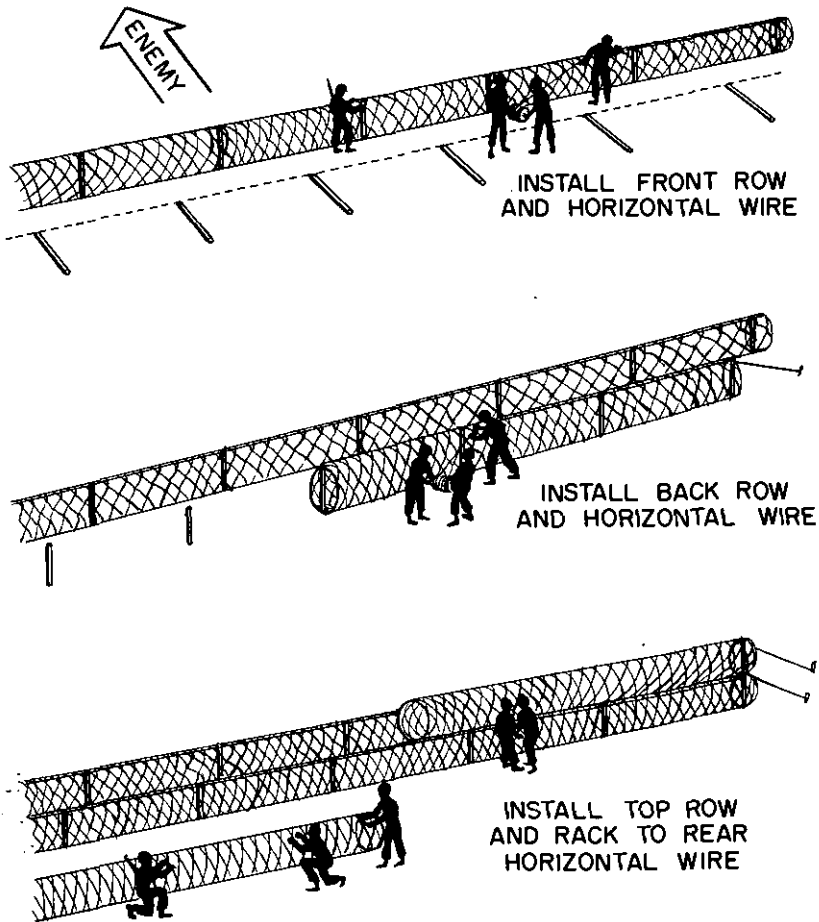

Figure 103. Installing concertinas.

b. *Second Operation.* As they complete the first operation, all men are organized in 4-man parties (par. 103) to open and install concertinas, beginning at the head of the fence. The sequence, shown in general in figure 103 is as follows:

- (1) Open the front-row concertinas in front of the double line of pickets and the other two in its rear.
- (2) Lift each front-row concertina in turn and drop it over the long pickets, then join concertina ends as shown in figure 104.

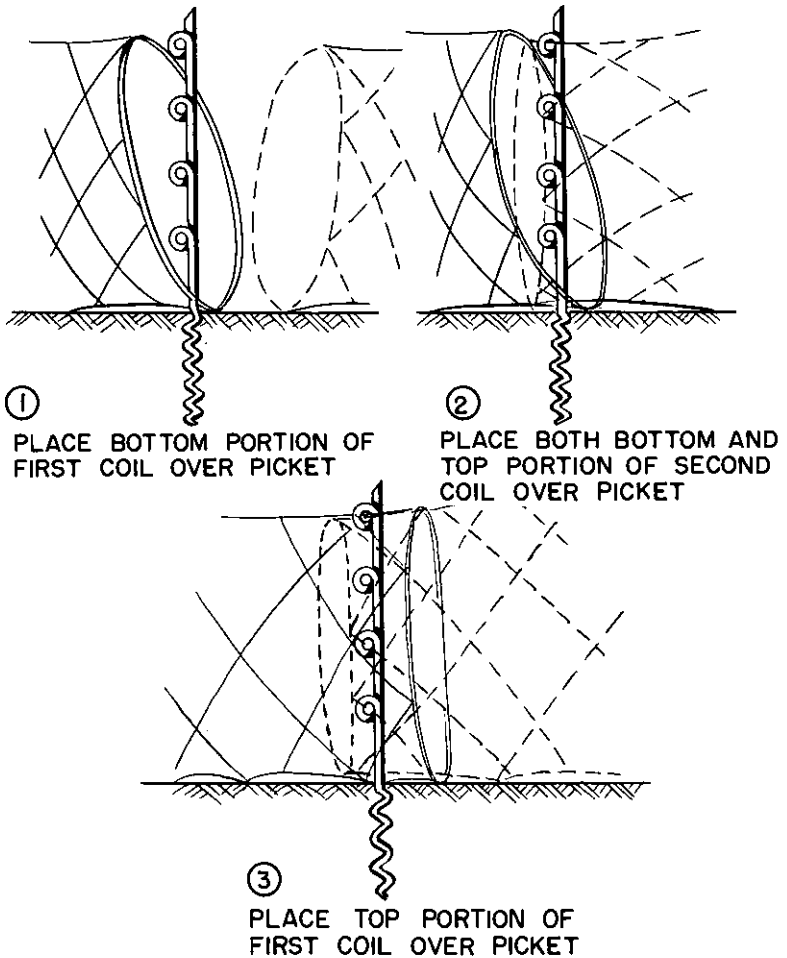

Figure 104. Joining concertinas.

- (3) Fasten the bottom of the concertina to the ground by driving a staple over each pair of end hoops, and one over the bottom of a coil at each long picket, and one at the $\frac{1}{2}$ and $\frac{1}{4}$ points of the $12\frac{1}{2}$ -foot picket spacing. Securing the front concertina to the ground is essential and must be done before installing

another concertina in its rear unless the enemy side of the fence is sure to be accessible later.

- (4) Stretch a barbed-wire strand along the top of each lower row and fasten them to the tops of the long pickets, using the top-eye tie for screw pickets. These wires are stretched as tightly as possible to improve the resistance of the fence against crushing.
- (5) Install the rear-row concertina as described in *b* above for the front-row concertina.
- (6) Install the concertina in the top row (fig. 103), fastening the end hoops of 50-foot sections with plain steel wire ties. Begin this row at a point between the ends of the front and rear of the lower rows, thus breaking all end joints.
- (7) Rack the top concertina to the rear horizontal wire at points halfway between the long pickets. If there is safe access to the enemy side of the fence, similarly rack the top concertina to the forward horizontal wire.

131. Portable Barbed-Wire Obstacles

Standard concertinas are readily moved and are well adapted for the temporary closing of gaps or lanes, or for adding rapidly to the obstacle effect of fixed barriers such as the double-apron fence. Other portable barbed-wire obstacles are—

a. Spirals of Loose Wire. By filling open spaces in and between wire entanglements with spirals of loose wire, the obstacle effect is substantially increased. Men are tripped, entangled, and temporarily immobilized. Spirals for such use are prepared as follows:

- (1) Drive four 3-foot posts in the ground to form a diamond 3 by 1½ feet.
- (2) Wind 75 yards of barbed wire tightly around the frame. Start winding at bottom and wind helically toward top.
- (3) Remove wire from frame and tie at quarter points for carrying or hauling to site where it is to be opened and used. One spiral weighs less than 20 pounds and a man can carry 3 or more of them by stepping inside the coils and using wire handles of the type furnished with the standard concertina.
- (4) If spirals are needed in large quantities, mount the diamond-shaped frame on the winch of a truck and use the winch to coil the wire.

b. Knife Rest. The knife rest (fig. 105) is a portable wooden or metal frame strung with barbed wire. It is used wherever a readily removable barrier is needed; for example, at lanes in wire obstacles or at road-blocks. With a metal frame it can be used as an effective underwater obstacle in beach defenses. Knife rests are normally constructed with 10 to 15 feet between cross members. They should be approximately

4 feet high. The cross members must be firmly lashed to the horizontal member with plain wire. When placed in position, knife rests must be securely fixed.

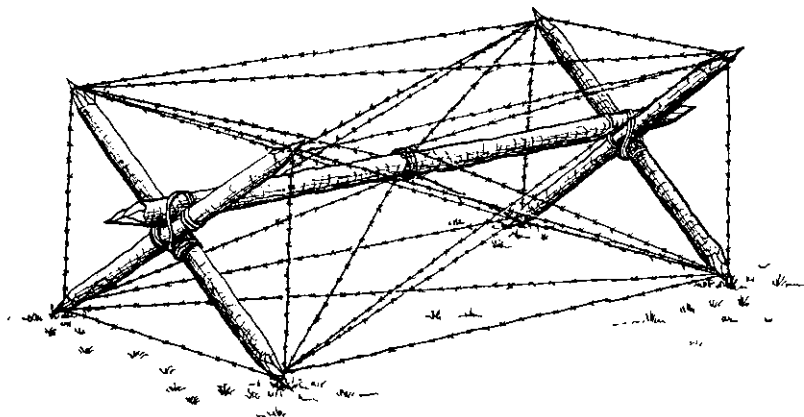

Figure 105. Knife rest.

c. Trip Wires. Immediately after a defensive position is occupied and before an attempt is made to erect protective wire, trip wires should be placed just outside of grenade range, usually 30 to 40 yards. These wires should stretch about 9 inches above the ground and be fastened to pickets at not more than 5-yard intervals. They should be concealed in long grass or crops or on a natural line such as the side of a path or the edge of a field. The trip wires should be placed in depth in an irregular pattern.

d. Tanglefoot. Tanglefoot (fig. 106) is used where concealment is

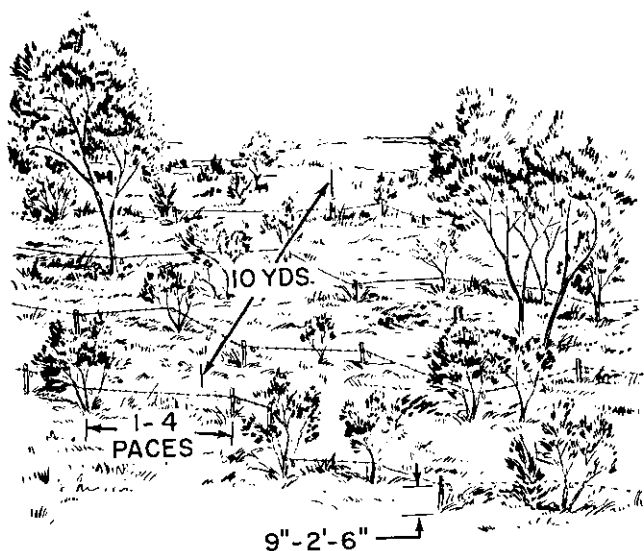

Figure 106. Tanglefoot.

essential. The obstacle should be employed in a minimum depth of 10 yards. The pickets should be spaced at irregular intervals of from 2½ to 10 feet, and the height of the barbed wire varies between 9 inches and 2 feet 6 inches. It should be sited in scrub, if possible, using bushes as supports for part of the wire. In open ground, short pickets should be used.

e. Trestle Apron Fence. The trestle apron fence (fig. 107) has inclined crosspieces spaced at 16- to 20-foot intervals to carry longitudinal wires on the enemy side. The rear ends of the crosspieces are carried on triangular timber frames which are kept from spreading by tension wires on the friendly side. The crosspieces may be laid flat on the ground for tying the longitudinal wires in place and then raised into position on the triangular frames. The frames are tied securely in place and held by the tension wires. The fence should be sited in such a way that it can be guyed longitudinally to natural anchorages and racked tight.

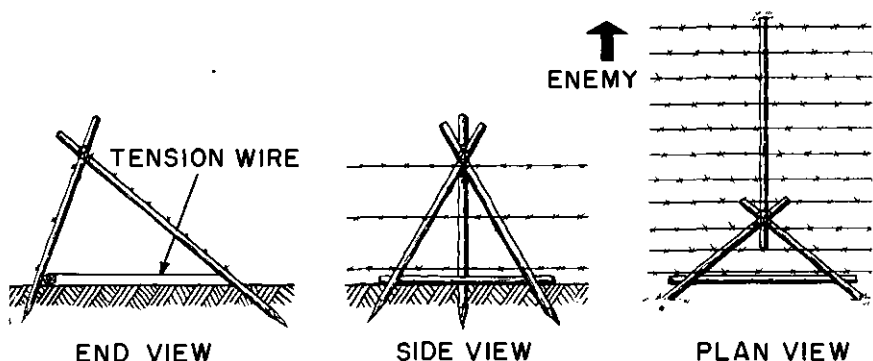
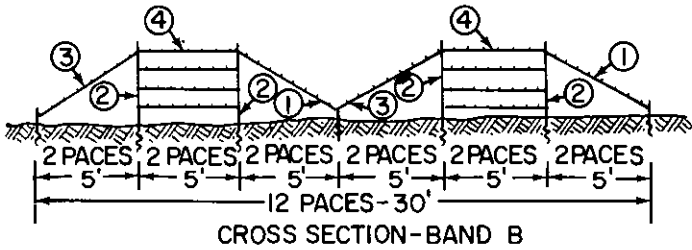
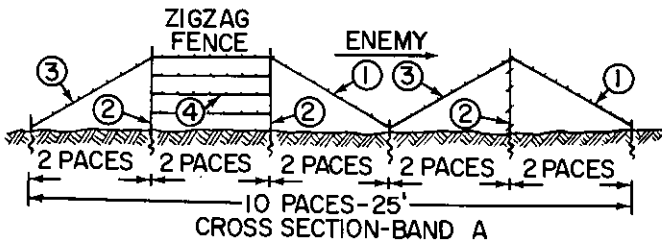
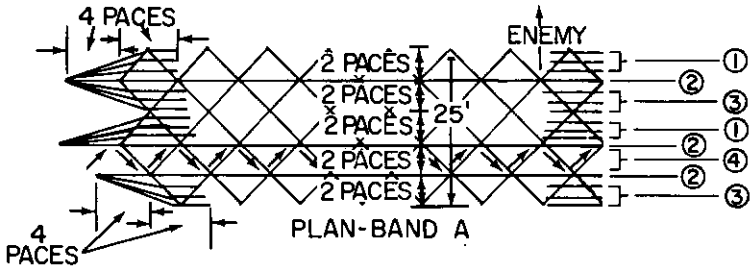

Figure 107. Trestle apron fence.

132. Combination Bands

As noted in paragraph 128, the high-wire entanglement may be built with additional rows of fences and triangular cells to form bands of any desired depth or may be made more effective by adding front and rear aprons. Other types of fences may be combined in bands to form obstacles which are much more difficult to breach than a single belt. Portable barbed wire obstacles may be added as described in paragraph 131. The construction of bands of varied types is desirable because this makes it difficult for the enemy to develop standard methods of passage and it permits fitting the obstacles to the situation and to the time and materials available. Six different types of effective combination bands are shown in figure 108. Other variations are readily developed.



- ① FRONT APRON
- ② CENTER FENCE
- ③ REAR APRON
- ④ ZIGZAG FENCE

Figure 108. Combination bands of wire obstacles.

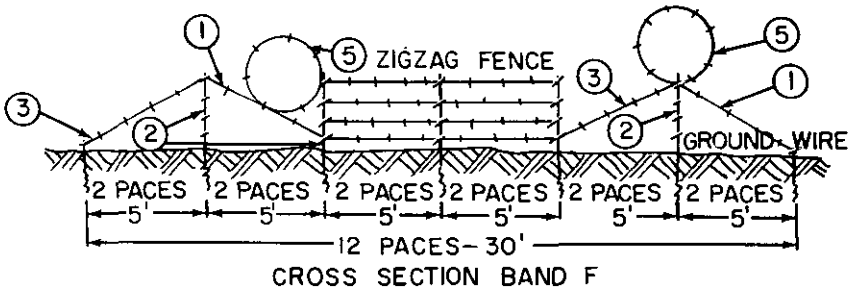
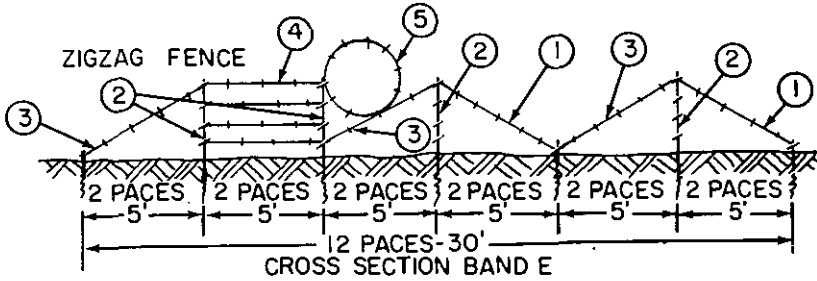
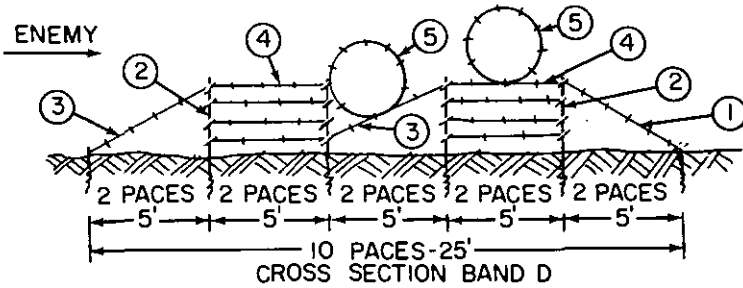
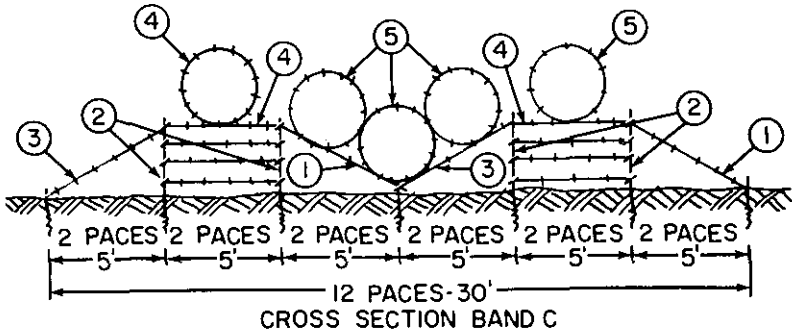

LEGEND:

- ① FRONT APRON ③ REAR APRON ⑤ CONCERTINA
② CENTER FENCE ④ ZIGZAG FENCE 4 STRAND

Figure 108—Continued.

Section III. MATERIAL AND LABOR ESTIMATES

133. General

Barbed wire obstacles are constructed primarily from issue materials, thus, both logistical and construction estimates are involved. Table XVIII gives weights, lengths, and other data required for estimating truck transportation and carrying party requirements. Table XIX gives the material and labor requirements for construction of various wire entanglements. Table XIX is based on daylight work; for night work the man-hours must be increased 50 percent.

134. Requirements for a Defensive Position

a. Method of Estimating. Table XIX gives quantities and weights of material per linear yard of entanglement. If a layout to scale can be developed, the lengths of the various types of entanglements are scaled and the quantities and weights are computed. If a scaled layout cannot be prepared, rules of thumb may be used for estimating the required lengths of tactical and protective wire entanglements. If the length of front is taken as the straight-line distance between limiting points, the rules are—

- (1) Length of tactical wire entanglement is $1\frac{1}{4}$ times the length of front, regardless of the size of the unit involved.
- (2) Length of protective wire entanglement for a defensive position is 5 times the length of the front being defended. Since protective wire encircles each platoon area of a command, the protective wire entanglement for units is taken as 2.5 times the average platoon frontage times the number of platoons involved.
- (3) Supplementary wire in front of the forward edge of the battle area (FEBA) is used to break up the line of tactical entanglements. Its length is $1\frac{1}{4}$ times the units frontage. The length of the supplementary wire entanglement behind the FEBA is approximately equal to $2\frac{1}{2}$ times the distance from the FEBA to the rearmost reserve unit. This rule of thumb is adequate for all units.

b. Example: GIVEN: A defensive position with a frontage of 1,800 yards and a depth of 900 yards. The tactical wire entanglement is a band consisting of three belts of triple standard concertina fence. The protective entanglement is a band consisting of two belts of 4- and 2-pace double apron fence. The supplementary entanglements are the same type and depth as the entanglements they supplement. Only screw pickets are available.

- REQUIRED: (1) Material to be requisitioned.
(2) Man-hours to construct.
(3) Number of $2\frac{1}{2}$ -ton truck loads (to per-

mit cross-country travel each truck will carry only $2\frac{1}{2}$ tons).

SOLUTION: Tactical.

- (1) Length of trace of entanglement $= 1.25 \times 1,800 = 2,250$ yards.
- (2) Sections of fence $= \frac{2,250 \times 3}{300} = 22.5$ sections, use 23.
- (3) Short pickets $23 \times 4 = 92$.
- (4) Long pickets $23 \times 146 = 3,358$.
- (5) Concertina $23 \times 54 = 1,248$.
- (6) Staples $23 \times 290 = 6,670$.
- (7) 400-yd reels $23 \times 2 = 46$.
- (8) Man-hours to construct $23 \times 27 = 621$.
- (9) $2\frac{1}{2}$ -ton truck loads $\frac{23 \times 300 \times 16}{2.5 \times 2,000} = 22.08$ truck loads, use 23.

Protective

- (1) Length of trace of entanglement $5 \times 1,800 = 9,000$ yards.
- (2) Sections of fence $\frac{9,000 \times 2}{300} = 60$ sections.
- (3) Short pickets $60 \times 182 = 10,920$.
- (4) Long pickets $60 \times 91 = 5,460$.
- (5) 400-yd reels $60 \times 12 = 720$.
- (6) Man-hours to construct $60 \times 54 = 3,240$.
- (7) $2\frac{1}{2}$ -ton truck loads $\frac{60 \times 300 \times 10}{2.5 \times 2,000} = 36$ truck loads.

Supplementary (in front of MLR)

Same as tactical requirements.

Supplementary (behind MLR)

- (1) Length of trace of entanglement $2.5 \times 900 = 2,250$ yards.
- (2) Sections of fence $\frac{2,250 \times 2}{300} = 15$ sections.
- (3) Short pickets $15 \times 182 = 2,730$.
- (4) Long pickets $15 \times 91 = 1,365$.
- (5) 400-yd reels $15 \times 12 = 180$.
- (6) Man-hours to construct $15 \times 54 = 810$.
- (7) $2\frac{1}{2}$ -ton truck loads $\frac{15 \times 300 \times 10}{2.5 \times 2,000} = 9$ truck loads.

c. Alternate Positions. If the plans include the preparation of alternate positions for the support platoon and the reserve company, the estimate is adjusted to include protective and supplementary wire for such positions, based upon any specific information that may be available.

CHAPTER 17

ANTIVEHICULAR OBSTACLES

135. Ditches

a. Types.

- (1) *Triangular ditches* (1, fig. 109). These are relatively easy to build but a vehicle stopped in a ditch of this type can usually back out and try another route.
- (2) *Sidehill cuts* (2, fig. 109). Sidehill cuts are variations of the triangular ditch adapted to sidehill locations and have the same advantages and limitations.
- (3) *Trapezoidal ditches* (3, fig. 109). These require about double the construction time of triangular type ditches but provide a much stronger obstacle effect. In a trapezoidal ditch as shown, the front end of the vehicle drops into the ditch as the center of gravity of the vehicle crosses the edge, and if the ditch depth exceeds the height of the vehicle wheels or treads, vehicles entering the ditch are trapped. Sections of ditch longer than 100 yards are not normally camouflaged. In winter, a trapezoidal ditch may be camouflaged by snow to resemble a standard trench (fig. 110).

b. Construction Procedures.

- (1) *Excavation.* Ditches are excavated by earthmoving equipment, by explosives as described in FM 5-25, or by handtools. To be effective, ditches made by explosives must be dressed to true surfaces by excavating equipment or handtools. Triangular and sidehill-cut ditches are constructed rapidly by a combination of explosives and motorized graders and angle-dozers. The actual time required varies widely in different types of soils. If available and if it can be used at the site of the ditching, the standard $\frac{3}{4}$ -yard shovel is used in ditch excavation. Estimating factors for construction time in average soil are shown in table XX.
- (2) *Revetting.* The face of the ditch, or both faces in the case of a trapezoidal ditch, should be revetted as soon as possible after it has been dug. Facing type revetting is used almost exclusively, with pole type or brushwood hurdles preferred because of their durability. For revetting techniques see chapter 7. It is particularly important that the top of the

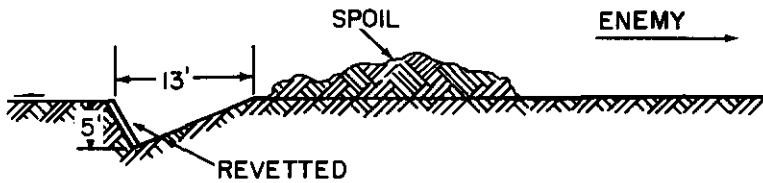

① TRIANGULAR DITCH

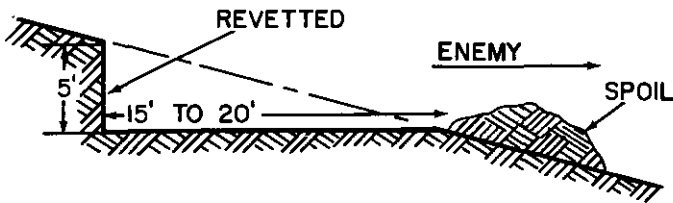

② SIDEHILL CUT

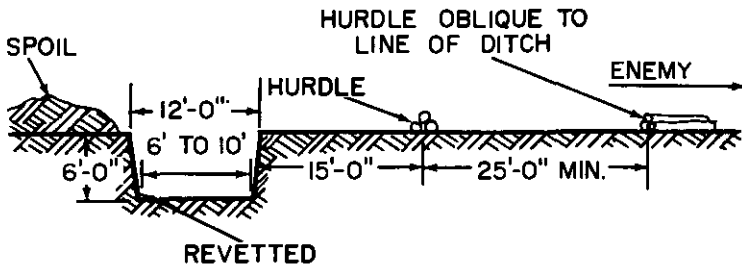

③ TRAPEZOIDAL DITCH

Figure 109. Types of antivehicular ditches.

revetment be about 8 inches below the top of the ditch and that the anchor stakes and tieback wires be buried under a foot of earth.

136. Craters

a. General. Crater-type obstacles are used for blocking roads, trails, or defiles, preferably at points where the terrain prevents bypassing the obstacle or where terrain suitable for bypassing can be mined and covered by antivehicular fire. Craters should be improved wherever possible by steepening the sides, flooding or mining.

b. Preparation. As in the case of bridge demolitions, craters are

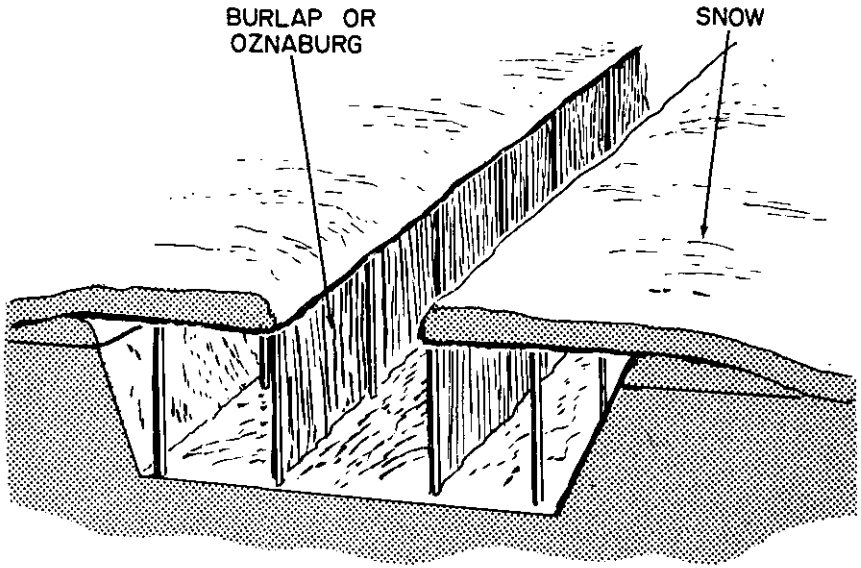

Figure 110. Antivehicular ditch camouflaged to resemble a standard trench.

Table XX. Estimating Data on Ditch Construction (Average Soil)

| Method of Construction | Dimensions of Ditch | | Crew Size | Construction Rate (ft/hr) |
|--|---------------------|----------------------|----------------------|-------------------------------------|
| | Depth (ft) | Width at Top (ft) | | |
| Handtools----- | 6 | 12 | Platoon ¹ | 13 (triangular) 7 (trapezoidal) |
| Explosives ² ----- | 10 | 30 | Squad ² | 25 |
| Earth Moving Equip----- | 6 | 12 | Platoon ¹ | 22 (triangular) 11 (trapezoidal) |
| ($\frac{3}{4}$ yd shovel, W/2 operators & 3-10 hand laborers). | | | | |

¹ 40 men.

² 13 men.

³ 12 pounds of ammonium nitrate per foot of length of crater.

formed by explosive charges placed in advance and prepared for later detonation. The weights of charges, depths, and arrangement are given in detail in FM 5-25. The methods normally employed include—

- (1) Placement of charges in a culvert under the road and concealed and wired for detonation from a safe distance.
- (2) If a culvert is not available at the point selected, charges are placed in the bottoms of holes excavated in the road. Truck-

mounted earth augers, if available, are used for digging the holes. The charges are placed and wired for detonation at a safe distance. The holes are backfilled in such a way that they are not readily noticed. The use of ADM to produce craters is covered in TC 5-8.

137. Log Hurdles and Cribs

a. Hurdles. Log hurdles formed of 10- to 18-inch logs as shown in figure 111 may be used to add to the obstacle effect of a crater, or other type of roadblock. The hurdles force vehicles to reduce speed as they approach the obstacles or they may act as an additional means of trapping vehicles in the vicinity of antitank ditches. Each hurdle consists of one 18-inch or three 10-inch logs firmly staked in place on a roadway or on ground suitable for use as a bypass. A hurdle of this size stops or damages most types of wheeled vehicles. Tanks can cross them at reduced speeds on reasonably level ground but are stopped by hurdles on uphill grades which approximate the critical grade of the vehicle. To stop a tank on such a slope, the size and location of the pole or log hurdle must be such that the ground line of the tank will be tilted to a slope of 1 to 1. The poles must be firmly tied between strong stakes at not more than 5-foot intervals. To determine the height of the hurdle required, a stick 12 feet long is held at an angle of 45° above horizontal, with one end of the ground downhill from the hurdle location. The distance between the upper end of the stick and the ground gives the required height of the hurdle. The hurdle should be sited on the steepest part of the slope and as near the top as possible.

b. Cribs. Rectangular or triangular log cribs (figs. 112-114) are used effectively as roadblocks where standing timber is available and where such an obstacle cannot readily be bypassed. Unless substantially built, obstacles of this type are not effective against heavy tracked vehicles. Cribs are strengthened by filling them with earth; and preferably the earth is obtained by digging a shallow ditch in front of the obstacle. Log hurdles in front of a log crib force vehicles to reduce speed and add to the effectiveness of the roadblock. An engineer platoon equipped with platoon tools can build 20 feet of this obstacle in 4 to 8 hours.

138. Posts

a. General. Posts are among the most effective of antivehicular obstacles because each post presents a breaching problem to the attacker. There is no fast method of breaching a belt of posts. Normally, the attacker will seek to bypass such an obstacle. Post obstacle belts may be constructed using either steel, log, or concrete posts.

b. Steel Posts. These posts are usually sections of rail, heavy pipe

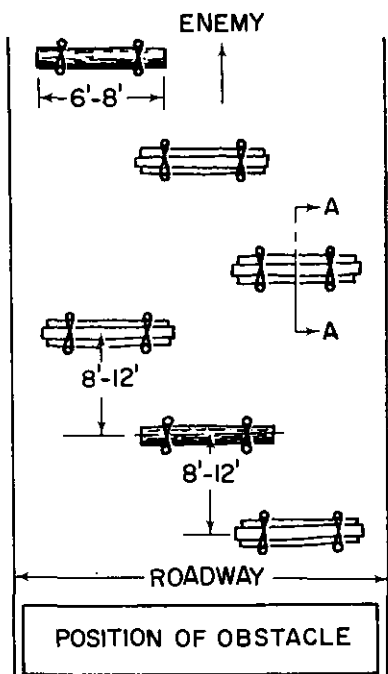

EMPLOYMENT OF STAGGARD
6'-8' HURDLES
(3-10" LOGS OR 1-18" LOG)

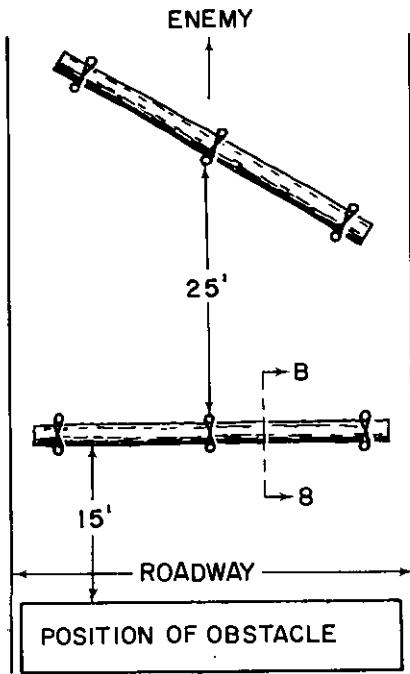

EMPLOYMENT OF 18"
LOGS AS HURDLES

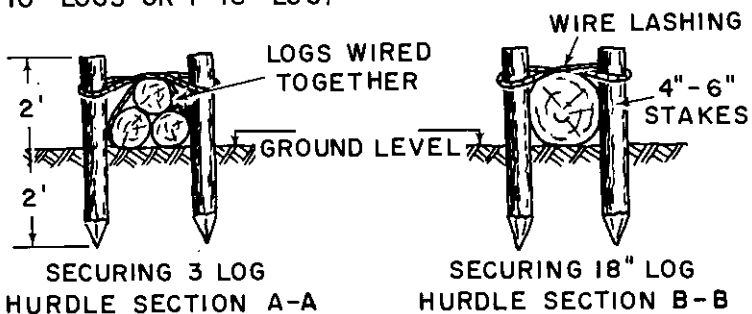

Figure 111. Types of log hurdles.

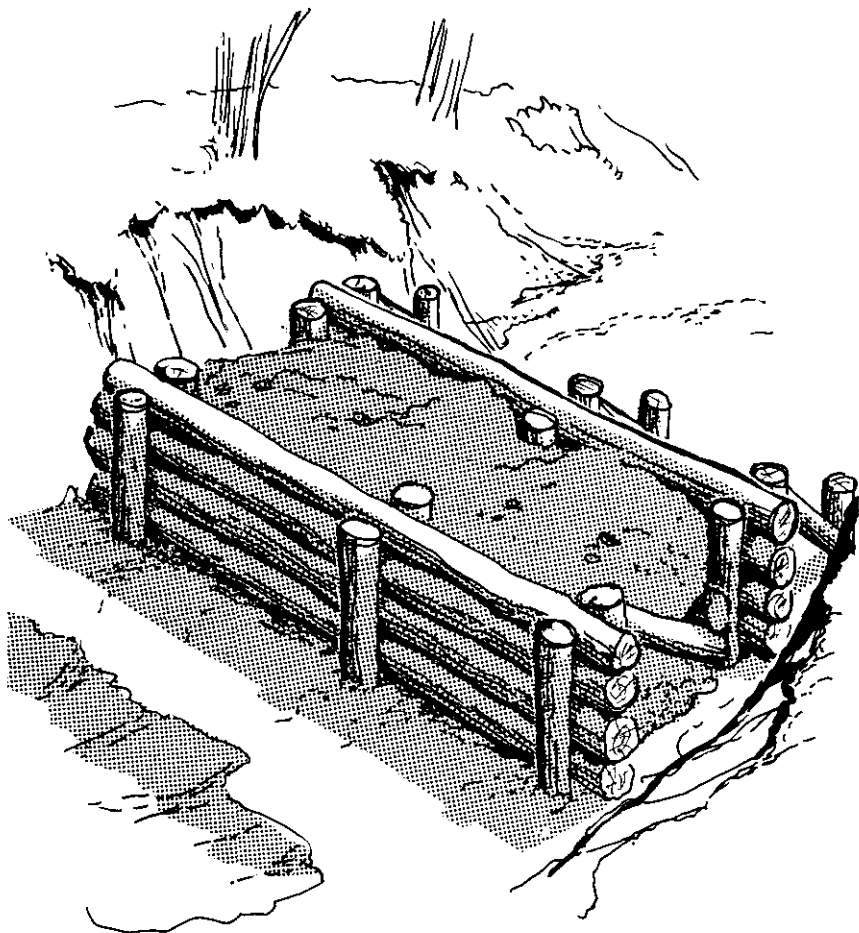

Figure 112. Rectangular log crib used as roadblock.

or structural members. Due to their small cross-sectional area, steel posts are installed over footings to prevent their being driven into the earth by the weight of a tank.

c. Log Posts. These posts should be hardwood with a minimum diameter of 15 inches. Footings are used under log posts only where the soil has exceptionally poor load-bearing characteristics. Figure 115 depicts a belt of log post obstacles.

d. Concrete Posts. Precast concrete posts may be emplaced either vertically or angled in the direction of the enemy line of approach using lengths, spacings and arrangements as described for wood or steel post obstacles.

- (1) Concrete posts should be square in cross section and 9 feet or more in length. They can be readily precast in horizontal open-top boxes with plank bottoms and removable sides and

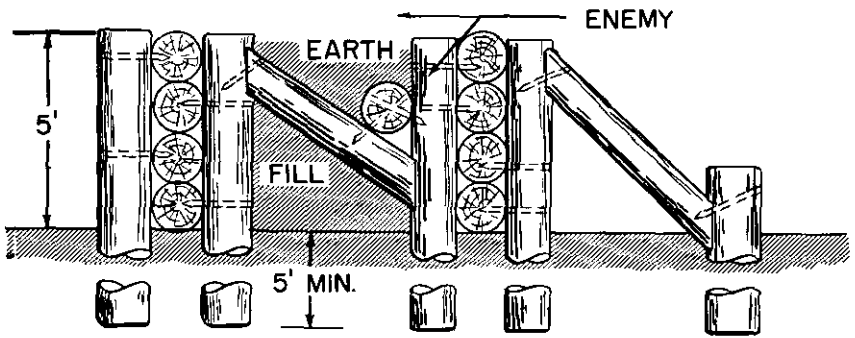

CROSS SECTION

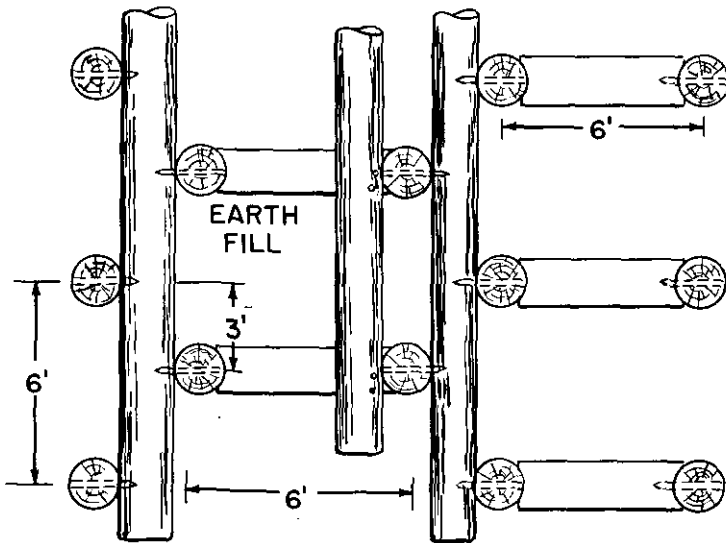

NOTE: ALL LOGS 8" DIAMETER (MIN.)

PLAN

Figure 113. Details of log crib used as roadblock.

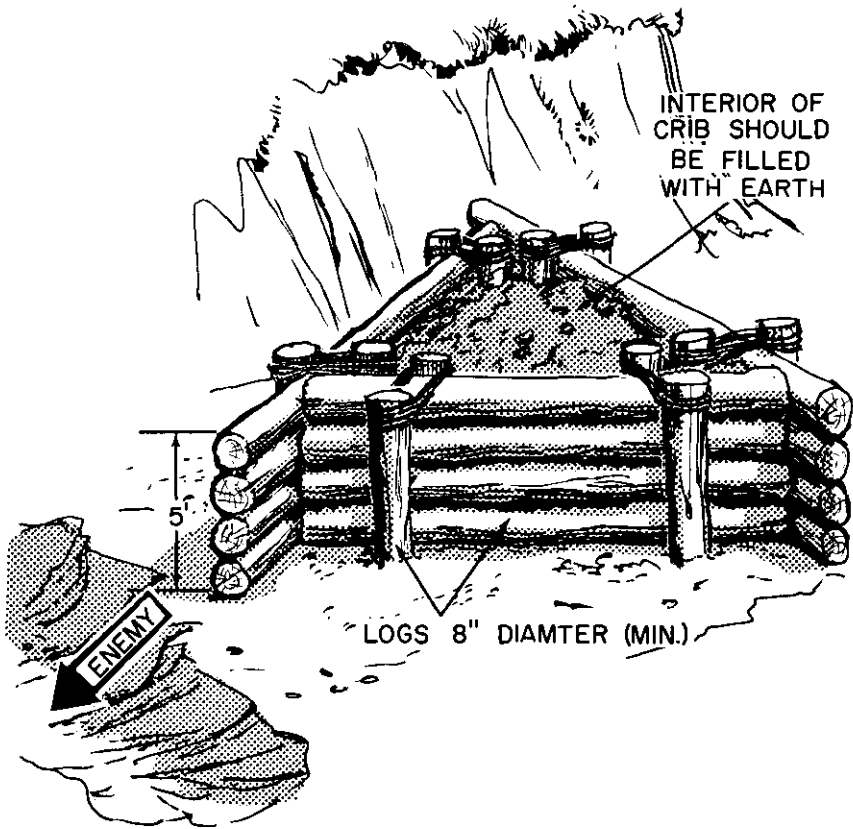

Figure 114. Triangular log crib used as roadblock.

ends. Two lifting rings are set in the top surface at the quarter points of the length, for loading and unloading; and a similar ring is positioned at the top end for raising it into position. A chisel-shaped point can be easily formed at the bottom end. Lengthwise reinforcement is provided several inches inside the surface near each corner of the square post, with a transverse wrapping of wire at each foot of length. Round reinforcing bars of $\frac{1}{2}$ -inch diameter are adequate for the longitudinal reinforcement. Reinforcement can be improved by using 4 to 6 strands of barbed wire at each corner, attached to the form ends and racked tight, preferably to almost the breaking strength of the wire. After curing for 1 week or more under wet burlap, such posts are installed in the same manner as described for wood posts or steel posts. If piledriving equipment is to be used, a steam or air hammer may be required for driving heavy posts of this type depending on the type of soil.

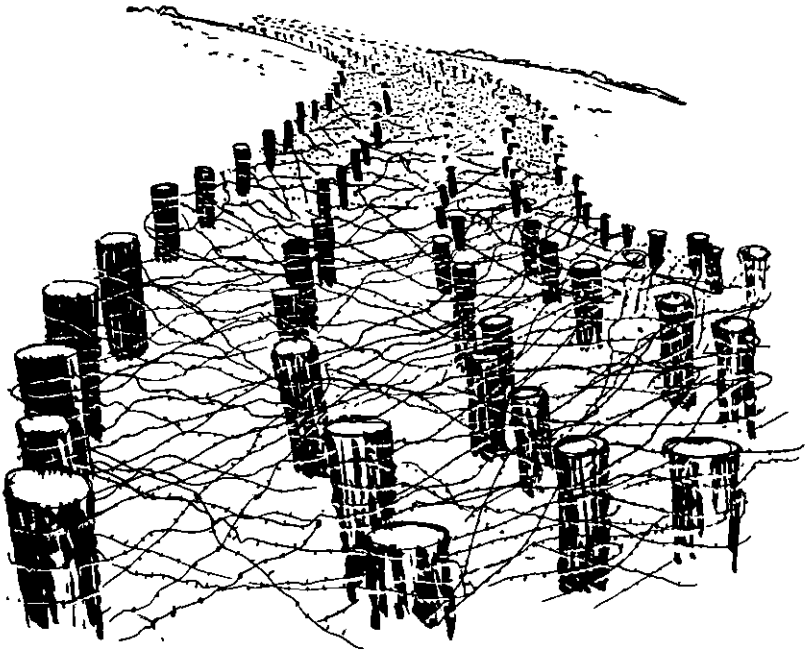

Figure 115. Belt of log post obstacles.

- (2) Round concrete posts may be improvised from corrugated metal pipe of small sizes filled with concrete. Because of the time required to funnel concrete into pipe held vertically and because of the expenditure of the pipe, this method is less efficient than the use of square precast concrete posts.

e. Placing.

- (1) All posts are buried 5 feet in the ground either vertically or at a slight angle toward the enemy, and project above ground level between $2\frac{1}{2}$ and 4 feet. The height should vary from post to post. The minimum acceptable density for posts is 200 per 100 yards of front. The spacing should be irregular, with at least 4 feet and not more than 6 feet between posts.
- (2) Posts are equally useful whether employed in long belts or in short sections as roadblocks. By pre-digging holes, lining them with pipe and covering them for later rapid installation of posts, the road may be kept open for use until the roadblock is needed. The rate of construction of such roadblocks is approximately as follows, based on a 20-foot road width:
 - (a) Using pile-driving equipment, 2 NCO's and 16 men: 4 to 6 hours.
 - (b) Using power earth auger or demolitions (shaped charges) 1 NCO and 8 men: 2 to $2\frac{1}{2}$ hours.
 - (c) Using handtools, one combat engineer platoon: 3 to 5 hours.

- (3) *Use of spirals of wire with posts.* The effect of post-type obstacles can be enhanced, and the obstacles made more difficult to breach, by weaving spirals of barbed wire among the posts as shown in figure 115. The belt illustrated is an anti-personnel as well as an antivehicular obstacle.

139. Abatis

a. *Use.* Trees felled as shown in figure 116 can be used to block a road or defile. To stop tracked vehicles the trees should be at least 2 feet or more in diameter and at least 20 feet long. To effectively block a road through a heavily wooded area, an abatis at least 75 yards deep is required.



Figure 116. Abatis used as roadblock.

b. *Construction.* Abatis may be constructed using handtools, by the use of explosives alone, or by a combination of notching and explosives as shown in figure 117. Using only handtools, 1 engineer platoon (40 men) can build 75 yards of abatis in 8 hours. Information on the use of explosives for the construction of abatis is contained in FM 5-25. Bushy-top trees with heavy branches and thick foliage should be used for abatis wherever possible since the branches reduce the momentum of the vehicle and the foliage sets up a screen. The trees should be felled as shown in figure 116 so that the trunk remains attached to the stump. To insure that the trunk remains attached no cut is made on the side of the tree toward which it is to fall, the tree is strained to fall in the required direction and the butt cut $\frac{2}{3}$ through on the opposite side. The effectiveness of an abatis is increased by interlacing barbed wire in the branches of the trees.

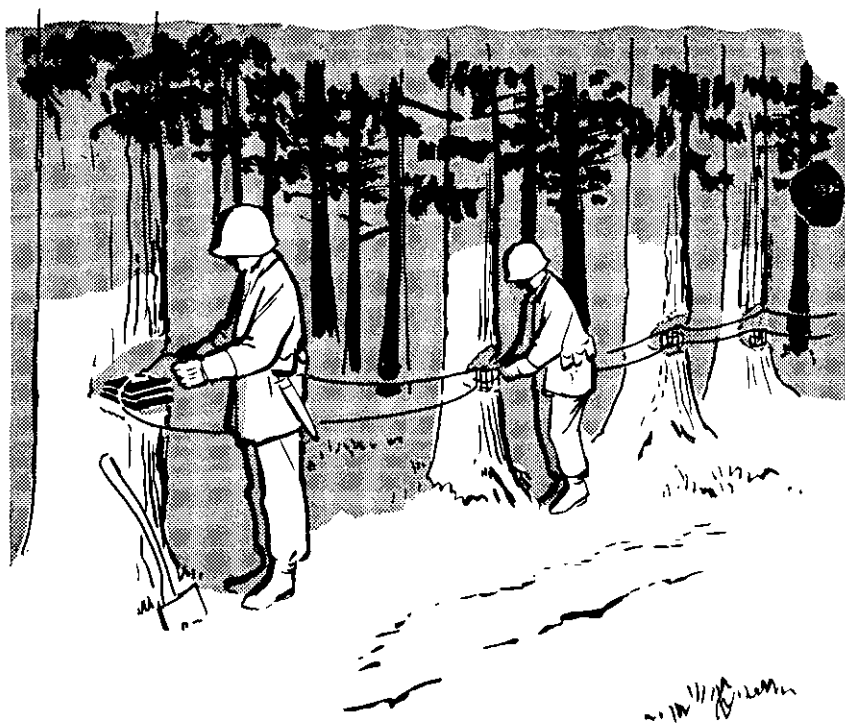

Figure 117. Preparing explosive charges for abatis construction.

c. *Tree Blowdown.* Air bursts of nuclear weapons over forested areas result in tree blowdown, creating an obstacle similar to an abatis. Table XXI shows the distance from the ground zero of the burst to which the mobility of foot soldiers and vehicles is adversely affected.

Table XXI. Effect of Tree Blowdown on Mobility (Forests Averaging 175 Trees Per Acre)

| Effect on mobility | Distance in miles from ground zero | | |
|--|------------------------------------|-----|-----|
| | Yield (KT) | | |
| | 1 | 10 | 50 |
| Area impassable to vehicles and very difficult for passage by foot soldiers. | 0.3 | 0.8 | 1.4 |
| Area passable to vehicles only after extensive clearing. | 0.4 | 1.0 | 1.8 |

140. Steel Hedgehogs

Steel hedgehogs as shown in figure 118 are relatively light in weight for the obstacle effect they provide, and they are quickly installed and removed. They are designed to revolve under wheeled vehicles and puncture them or to belly up tracked vehicles. Unless kept under observation and covered with fire, the enemy can readily move them aside. They are well adapted for use in vegetation high enough to afford

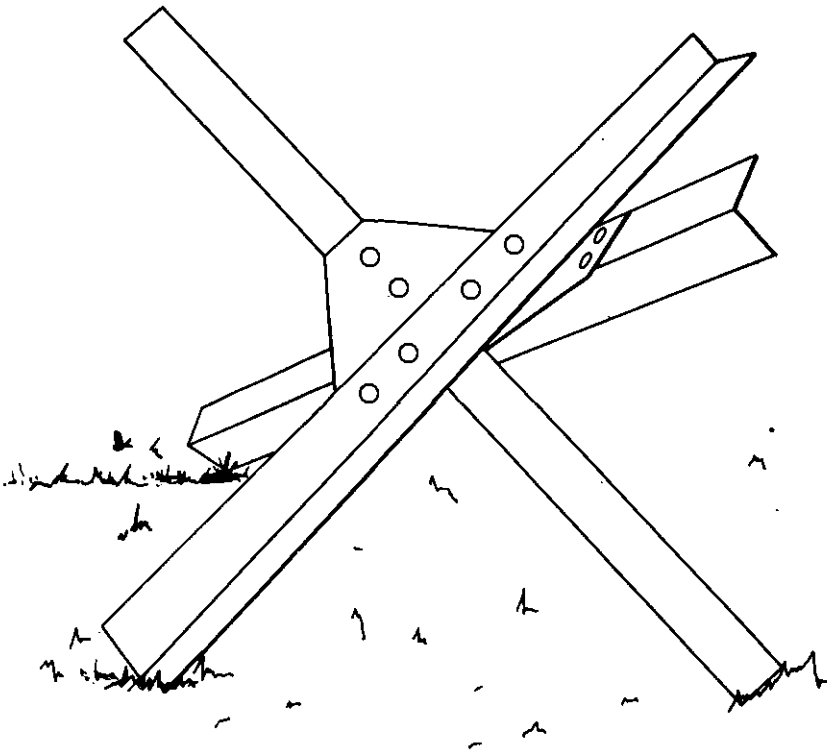
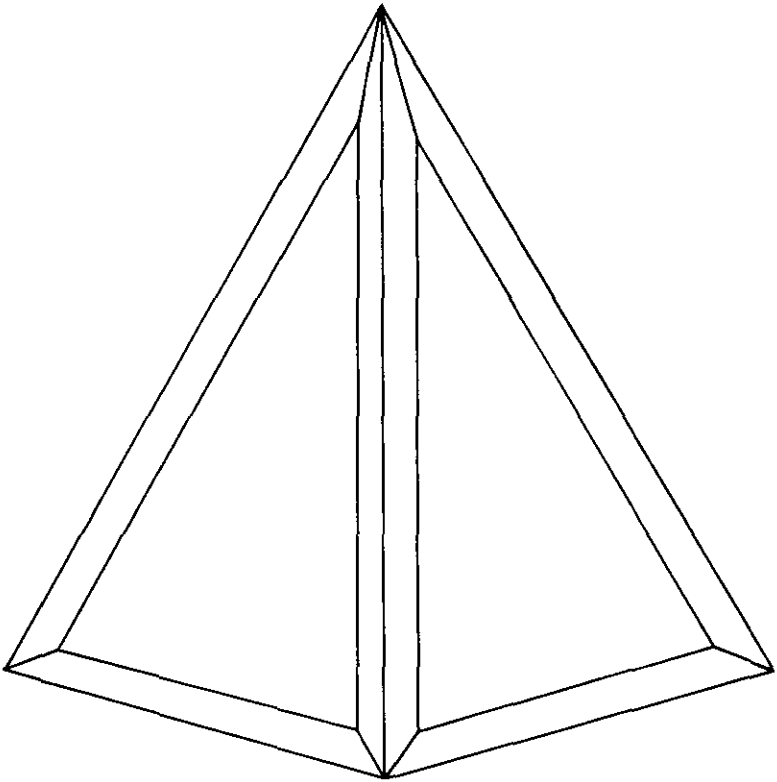

Figure 118. Steel hedgehog.

complete or partial concealment. Exposed parts should be painted to blend with the background. Hedgehogs are made up in rear areas, using 3 angles about 4 inches by 4 inches by $\frac{5}{16}$ inch, 4 feet long, and a $\frac{5}{16}$ -inch steel plate about 20 inches square. A hedgehog of this size weighs about 160 pounds. Hedgehogs are used in rows, with at least 150 hedgehogs to each 100 yards of front which is to be protected in this manner.

141. Steel Tetrahedrons

Steel tetrahedrons as shown in figure 119 are employed in a manner similar to that of hedgehogs. They are usually made of 4-inch by 4-inch by $\frac{1}{2}$ -inch angles, the base and sides in the shape of equilateral triangles, 5 feet on a side. Their finished height is approximately 4 feet.



STEEL TETRAHEDRONS

Figure 119. Steel tetrahedrons.

142. Concrete Cubes

Cubes are concrete obstacles of approximately cubical shape, set in irregular rows. A typical size and arrangement is shown in figure 120. Because of the weights involved and the simplicity of erecting forms

for cubes, these obstacles are best cast in place if the situation permits. A cube of the size shown in figure 120 requires about 2.4 cubic yards of concrete and weighs slightly less than 5 tons.

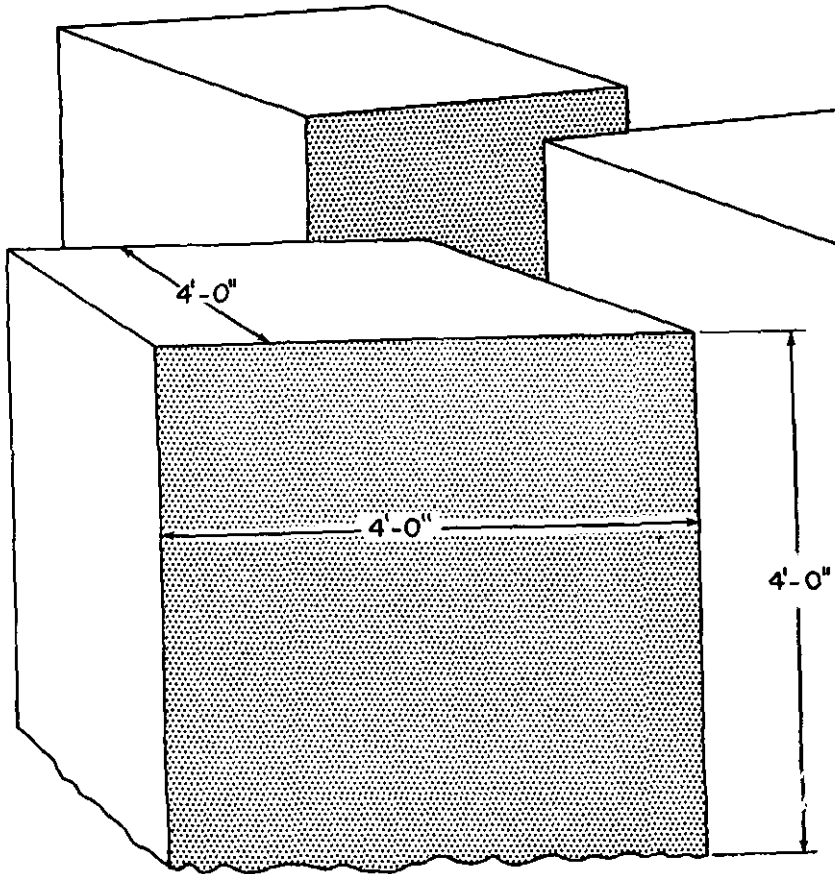

Figure 120. Concrete cubes

143. Concrete Cylinders

Concrete obstacles of cylindrical shape are usually smaller than cubes and are light enough to be precast. Their use is similar to that of cubes, and they may be preferable in situations in which precast obstacles are the type required. Cylinders may be precast in forms made of lightweight sheet metal which need not be removed. A cylinder of the size shown in figure 121 requires 1.35 cubic yards of concrete and weighs a little less than 3 tons.

144. Concrete Tetrahedrons

Concrete tetrahedrons are pyramids with base and sides of equilateral triangles, 5 feet on a side. They are set in irregular rows as shown in

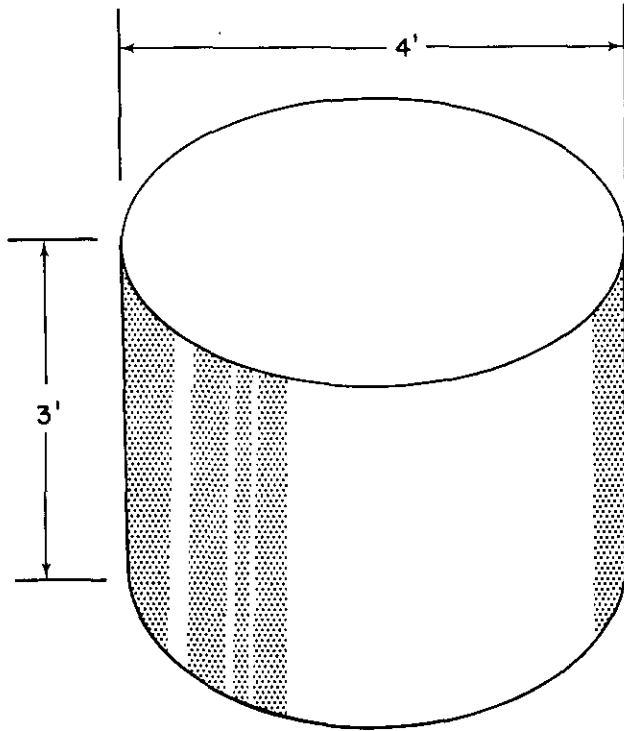

Figure 121. Concrete cylinders.

figure 122. A tetrahedron of this size has a vertical height of about 4 feet 1 inch, requires 0.55 cubic yard of concrete, and weighs about 1.1 tons. They may be precast in trough-shaped forms between triangular divisions, with a lifting ring embedded in the center of the top surface of each tetrahedron.

145. Expedients

a. Roadblocks may be improvised from farm carts, automobiles, and trucks, which are loaded with rock, concrete, or other heavy material. When placed in position their wheels should be damaged or removed, and the vehicles should be firmly anchored.

b. Vehicles can be moved to close a gap that has been left to keep the road open.

c. A roadblock which may be effective in some situations is constructed quickly by the method shown in figure 123. A heavy tree at one side of a road is cut almost through and its trunk is attached by a wire rope to a tree across the road in such a way that if a passing vehicle strikes the rope the tree will fall and damage the truck or pin it in place.

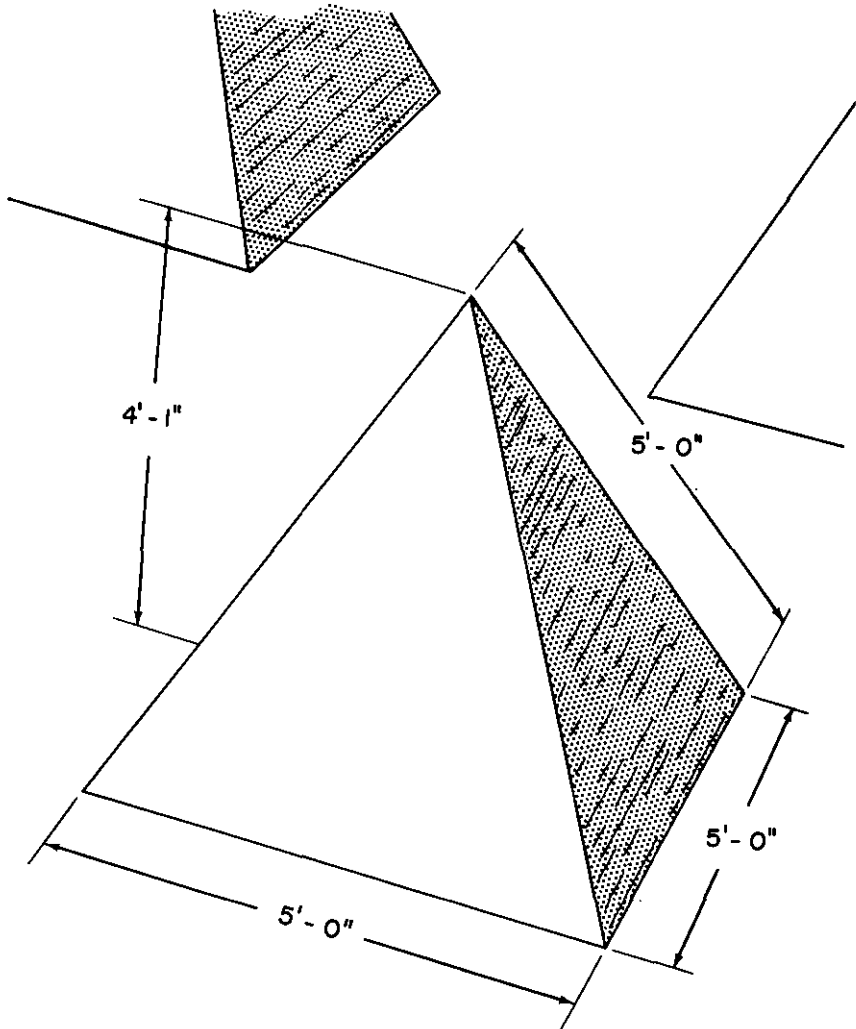

Figure 122. Concrete tetrahedrons.

d. Plain wires stretched across a road at a height of 3 to 6 feet will sometimes decapitate vehicle drivers. Fencing, telegraph or telephone wires may be used, stretched tight and attached firmly to trees, telephone pole, walls or fences. The wires should make an angle of between 45° to 90° with the line of the road.

e. A good winter weather road obstacle is constructed by using a heavy wire rope stretched at 45° across the road at a height of about 3 feet. The rope should be located just over the top of a hill or around a blind corner on a downhill grade. Slant the wire rope to divert the vehicle over a steep embankment, into a deep ditch, or into a tree.



Figure 123. Wire-rope roadblock.

146. Use of Screens and Phony Obstacles

a. Purpose. Wherever possible, antivehicular obstacles, particularly roadblocks, should be concealed by screens for the following reasons:

- (1) In order to conceal the true nature of the obstacle.
- (2) In order to prevent fire from being directed at the most vulnerable part.
- (3) In order to confuse the crew of the vehicle. Screens should also be erected in front of phony obstacles and at sites where no obstacle exists, causing delay and expenditure of valuable ammunition. The enemy force will not know with any certainty what form of obstacle or defense opposes it or whether any real obstacle exists. If the force stops to investigate, the defense will have an opportunity to destroy it; if it goes ahead it runs the risk of running into mines or of being held on an obstacle under fire.

b. Siting. Screens should be sited not more than 10 feet from the obstacles which they are concealing. If a vehicle goes through a screen at this distance, it will encounter the obstacle before it can halt. It will therefore not be in position to fire at the obstacle. Screens must not obscure the fields of fires of the defenders.

c. Construction. A form of screen, suitable for concealing a roadblock, consists of 2 horizontal strips of canvas, garnished netting, or

blankets; the lower part suspended from wires about 4 feet from the ground, and the upper part at a height of 7 to 8 feet. The upper part should overlap the lower part by 6 to 13 inches.

d. Phony Obstacles. Phony obstacles should be used extensively to confuse and delay tanks and cause them to waste ammunition. They should be carefully made in order to present a realistic appearance. They can be made of plaster, wood, or asbestos sheets. Wooden obstacles can be used to represent steel obstacles. Antitank and anti-personnel mines should be interspersed extensively between phony obstacles.

CHAPTER 18

NATURAL LAND OBSTACLES

147. Types

Natural terrain features such as streams, steep banks, ravines, swamps, and existing walls can be used as obstacles. They are exploited by tying in with artificial obstacles or by improvement as described below.

148. Methods of Improving Natural Land Obstacles

a. Bank Cutting and Stream Deepening.

- (1) *Bank cutting.* The banks of streams, ravines, ditches and embankments may be cut to increase the dimensions and to present a nearly vertical face to approaching vehicles. Spoil, logs, and if necessary, revetments are placed on the friendly side to increase the strength of the obstacles. Hurdles may be placed on the enemy side.
- (2) *Stream deepening.* Under some conditions a fordable section of a stream may be deepened by cutting a channel along the near shore, preferably with equipment of dragline type working in the fordable streambed. If possible the cut should result in a nearly vertical face at the shoreline. If the inshore terrain permits its concealment, and timber is available, it is advisable to deposit the spoil in a log crib built along the near shore. In other situations it may be desirable to dispose of the spoil in the fordable part of the streambed, to haul it downstream through the shallow water to deeper water, or to move it downstream on scows.

b. Flooding. Lowlands may be flooded by cutting dams, levees or dikes, or by preparing demolition charges to cut them on command. Because the water may remove an otherwise effective obstacle in a nearby area, or flood out defensive positions, such action requires careful control and liaison between adjacent organizations. Accurate information should always be obtained from local sources before flooding is carried out. Since it will render an area impassable for long periods to any but the lightest traffic, flooding is advisable only when a strategic withdrawal followed by a static defense is intended. In addition, reinstatement of the normal drainage and water control system may be a very difficult task in the subsequent advance. Local flooding may be

carried out in antitank ditches and small streams, swamps, and ditches without orders from higher command.

c. Bridge Demolitions. Bridge demolitions by explosive charges are readily prepared in advance for detonation at the proper time as described in FM 5-25. They add to the obstacle effect of any stream and are more effective if the stream is deep enough and wide enough to stop tracked and wheeled vehicles. Water 3 feet deep stops most wheeled vehicles which are not waterproofed; water 6 feet deep stops nearly all vehicles up to and including medium tanks. Demolition of an overpass over a highway requires bypassing traffic on both roads if the resulting debris also blocks the overpassed road effectively.

d. Snow and Ice Obstacles.

- (1) *Increasing the obstacle effect.* Deep loose snows and icy roads are obstacles which lend themselves to improvement in a variety of ways. Roadside ditches may be deepened and widened to tank-trap size, then permitted to fill with loose snow. Hillside roads or crowned earth roads may be sprinkled with water to freeze. In deep snow, movement of heavy tracked and wheeled vehicles is usually impossible except on cleared roads, thus road obstacles assume special importance. Under winter conditions or in the arctic, studies are made of prevailing winds, temperature, and snowfall predictions so that snow fences can be installed or existing fences moved, to induce drifting over or across roads.
- (2) *Vehicle traps of packed snow.* Two or more parallel embankments, of cross sections as shown in figure 124, are effective as antivehicular obstacles. The snow must be packed hard, preferably by bulldozers or graders. If sited on a forward slope, the effectiveness of this type of obstacle against enemy vehicles is increased, and friendly vehicles can overrun it. A light fall of new snow provides effective camouflage, and drifting snow makes the outlines indistinct.
- (3) *Tank traps in ice.* In crossing frozen lakes or rivers, heavy tracked or wheeled vehicles usually follow paths which have

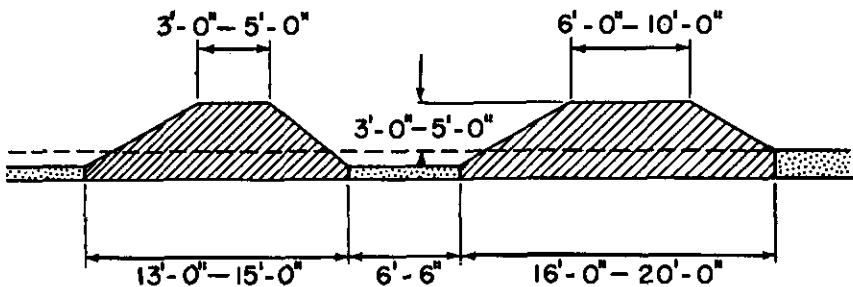

Figure 124. Antivehicular obstacle of packed snow.

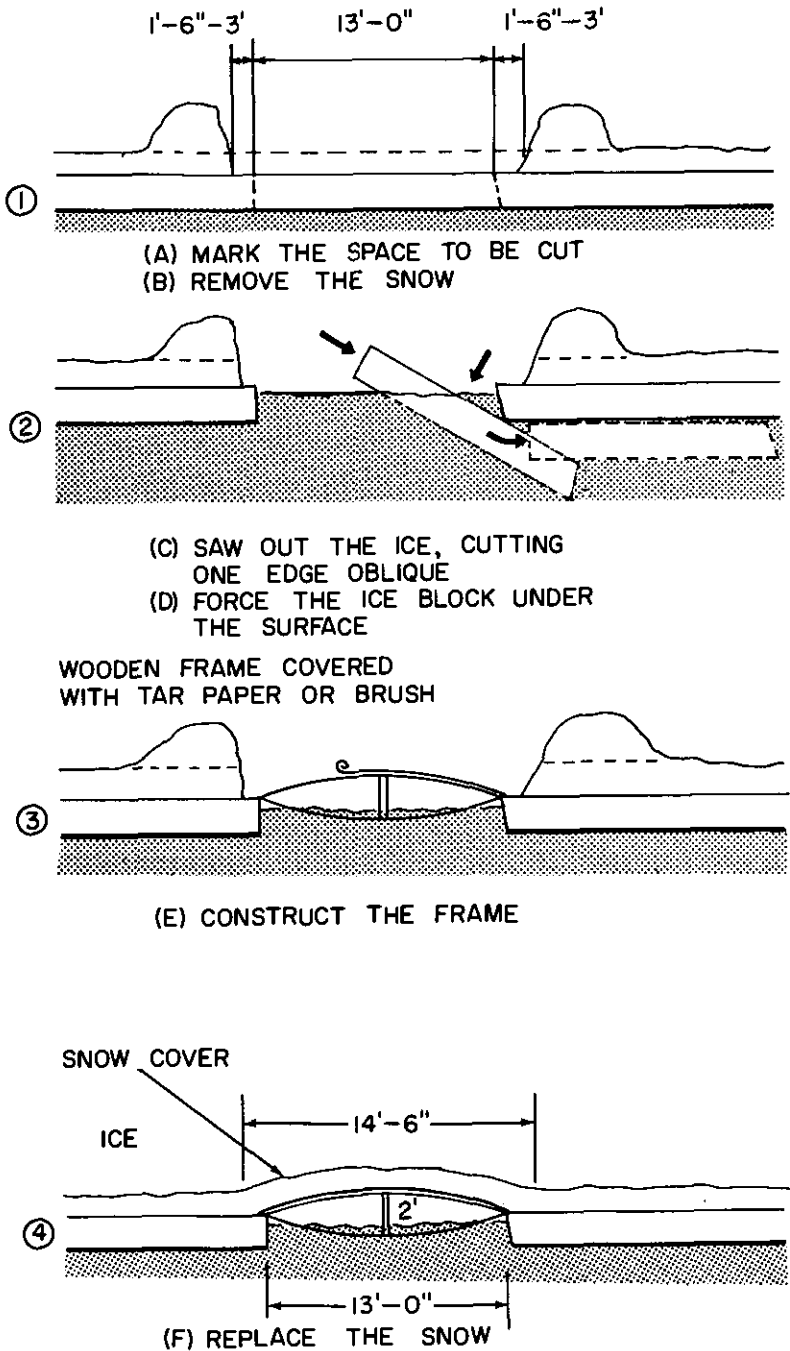

Figure 125. Vehicle traps in ice.

been explored and found to have safe carrying capacities. Such paths may be trapped as shown in figure 125. An opening 10 to 13 feet wide is cut in the ice, and the cut blocks are slid under the firm ice where they are carried downstream by water action. The open lane is then closed with a light wooden frame covered with burlap, brush or tarpaper and topped with snow. The effectiveness of the obstacle depends upon maintaining a snow cover at least 4 inches thick, to keep the ice from refreezing.

CHAPTER 19

BEACH AND RIVER LINE OBSTACLES

149. General

Most of the types of obstacles described in paragraphs 145 through 148 can be used as antiboat obstacles for some types of boats in water depths for which they are adapted and in which they can be sited and anchored. The tide range determines the water depths for which it is practicable to position obstacles on the bottom above the low waterline. Outside this line, heavy obstacles may be sunk from boats or lowered by cranes operating from the beach or afloat in small landing craft. Posts of timber, steel, or concrete are effective antiboat obstacles, readily placed except in rocky or coral bottoms. Posts are preferably emplaced or driven with a slope or batter toward deep water. Wooden obstacles of other types should be filled with rock or otherwise anchored in position. Antiboat obstacles may be connected with wire rope or may have barbed wire or other types of obstacles anchored between them. In rivers or other locations where the water level is constant or the tide range is minor or negligible, standard cased antitank mines tied to posts or other obstacles under the surface provide effective obstacles.

150. Timber Obstacles

Unpeeled round logs provide the types of antiboat obstacles described and shown, but sawed timbers may be used if more readily available. In addition to the uses of wooden posts described in paragraph 138, timber obstacles of the following types are used effectively under various conditions:

a. Rock-Filled Cribs and Pillars. Rock-filled timber cribs (fig. 126) are normally 6 to 10 feet long by 3 to 4 feet wide, and have stability at heights up to 6 or 7 feet. The logs are driftpinned at the corners. Cribs may be installed on a beach at low water or may be dragged or lowered into water before completing the rock fill. For lower heights smaller cribs, triangular in shape and known as pillars (fig. 127) are built with less material and effort. Both types may be connected by barbed wire, wire rope, or a combination of both.

b. Tetrahedrons. Timber tetrahedrons (fig. 128) are pinned and wired to a triangular bottom frame which is weighted in place with rocks. A post may be driven through the obstacle for improved anchorage. Tetrahedrons are normally spaced at intervals of 15 to 30 feet

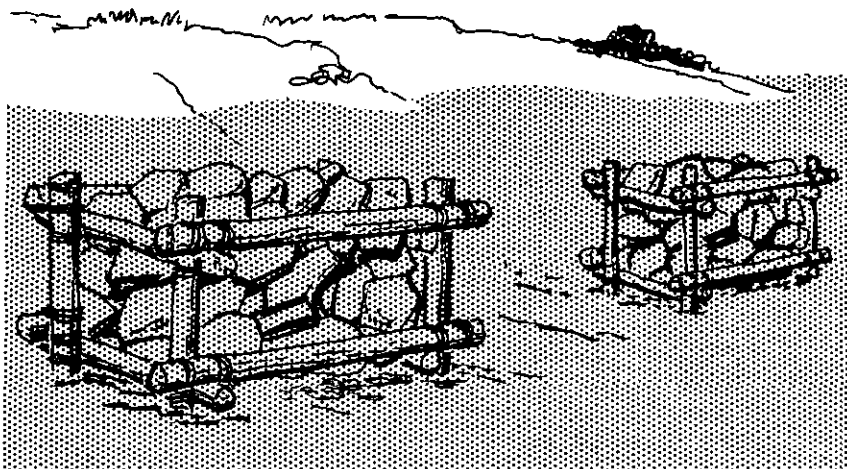

Figure 126. Rock-filled cribs.

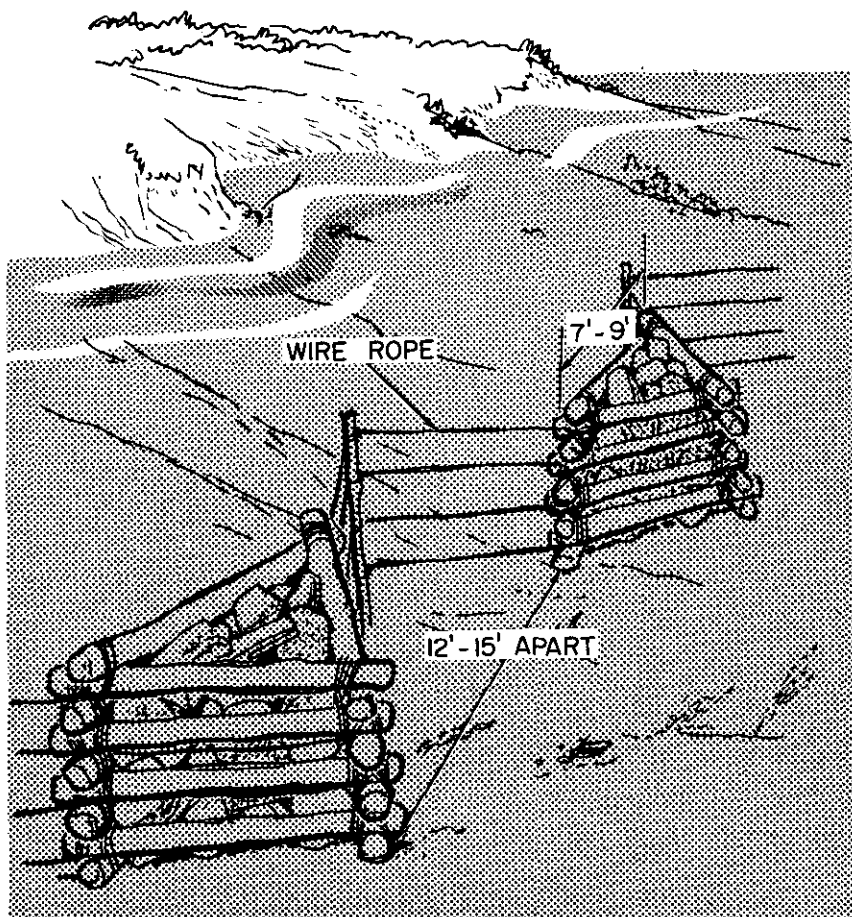

Figure 127. Rock-filled pillars.

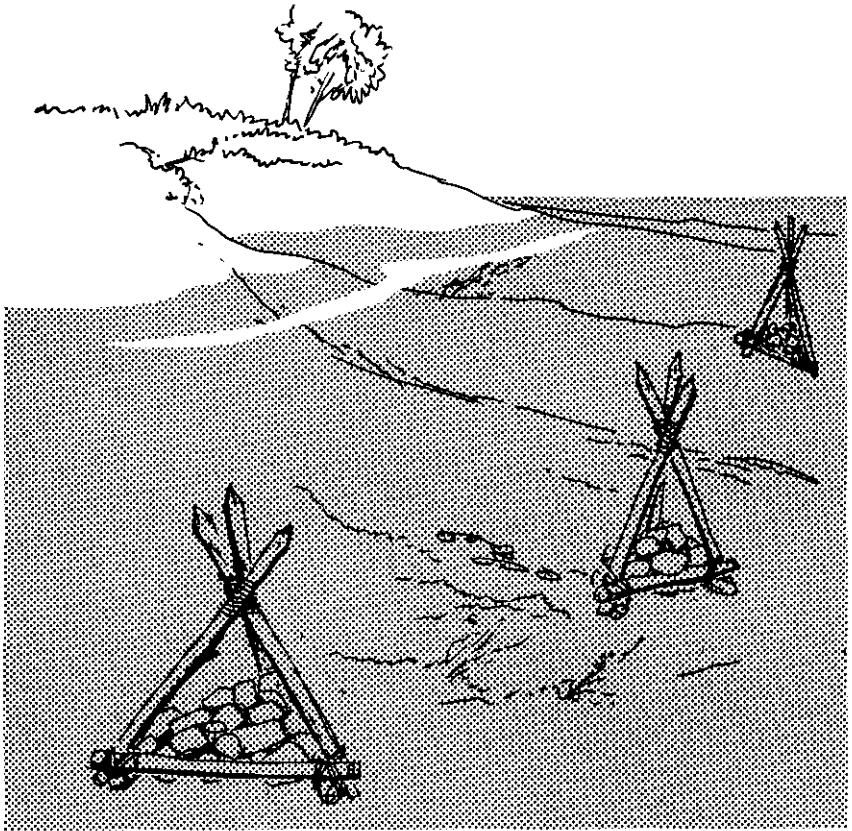

Figure 128. Timber tetrahedrons.

and may be connected with wire rope or incorporated in a barbed wire fence.

c. Log Scaffolding. In suitable water depths, log scaffolding, as shown in figure 129, is effective in impeding small boats. Wooden posts driven into the bottom are reinforced by diagonal braces extending inshore and have horizontal stringers attached to the offshore face.

d. Braced Wooden Posts. This obstacle, shown in figure 130, may be built in relatively shallow water in which there is little or no tide range. The posts are driven approximately to water level in two rows staggered so that diagonal braces can extend from each rear post to two of the front posts to provide a structure of exceptional rigidity. The bottom ends of the braces may be fastened to the rear posts before the latter are fully driven and before the work is so deep as to require diving equipment. The front posts may be connected with wire rope or barbed wire to further improve the rigidity of the structure and to add to the obstacle effect. The efficiency of this obstacle is further enhanced by the liberal use of barbed wire tangles securely fastened to and between the posts.

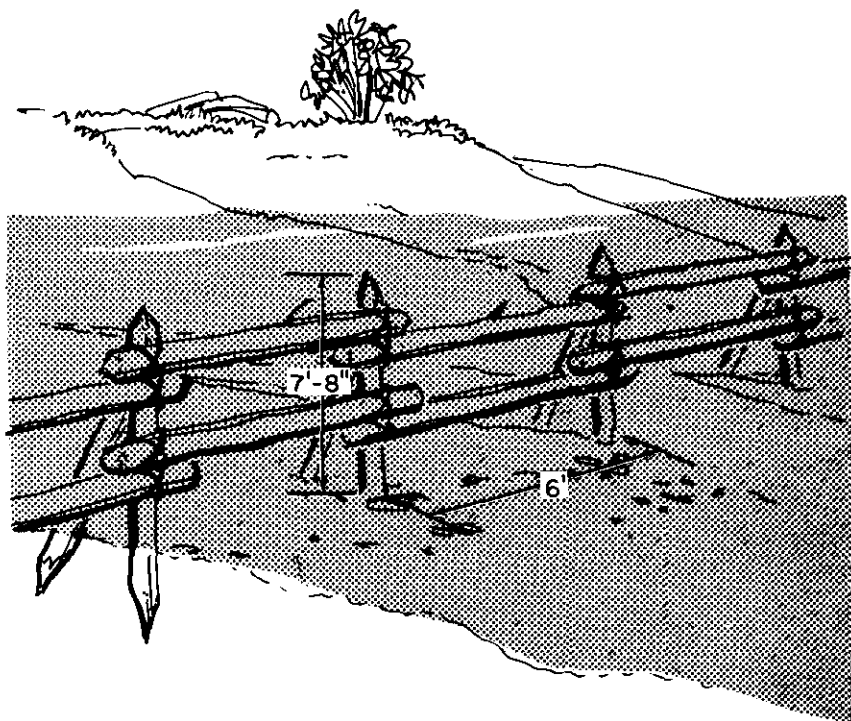

Figure 129. Log scaffolding.

e. Log Tripods. Braced log tripods, constructed of logs at least 8 inches in diameter, as shown in figure 131, are effective antiboat obstacles. The obstacle is positioned with its longest leg facing the direction of expected assault, and this leg may be capped with a standard antitank mine or sharpened to a point. Constructed in varying sizes so they are covered by 1 to 2 feet of water at high tide, these obstacles are placed on beaches from the low-tide mark back to about halfway to the high tide line.

f. Log Ramps. Log ramps are constructed as shown in figure 132. They are used to tear the bottoms out of assault craft riding up on them, and to upset such craft. They are effective obstacles with or without mines fastened to the high end of the ramp. Ramps may be placed either in an irregular pattern or in a continuous belt spaced at approximately 10-foot intervals.

g. Nutcrackers. Nutcrackers are constructed as shown in figure 133. The 3- by 3- by 2-foot base has a center well or recess large enough to house 1 or 2 antitank mines, depending on whether a 1-way or 2-way obstacle is desired. It also has a built-in socket for the bottom end of the activating rail or pole. Shear pins, usually of $\frac{1}{4}$ inch soft iron, hold the rail erect and prevent detonation of the mines by wave action. A

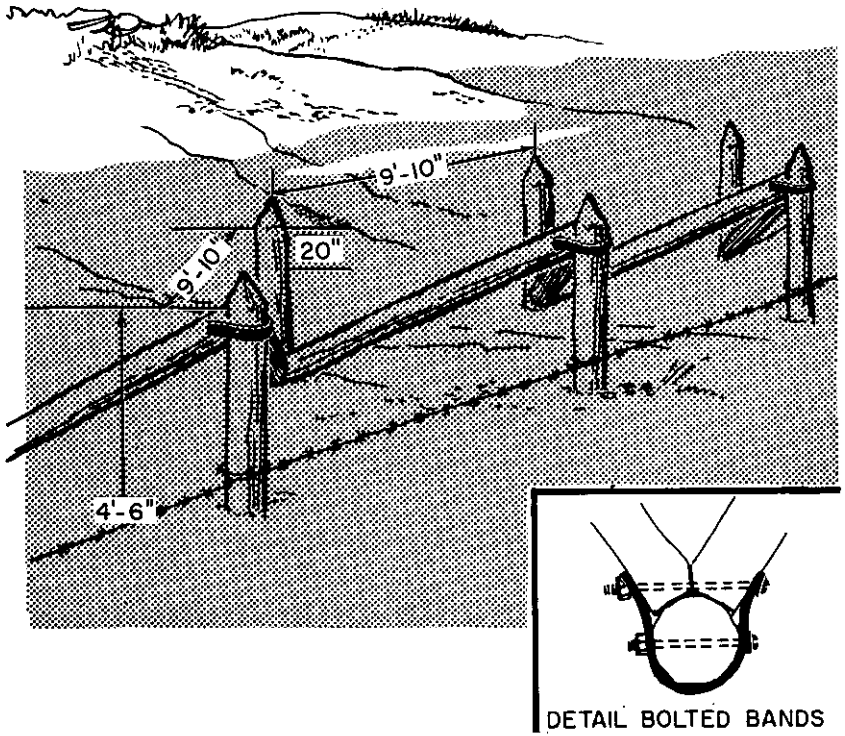
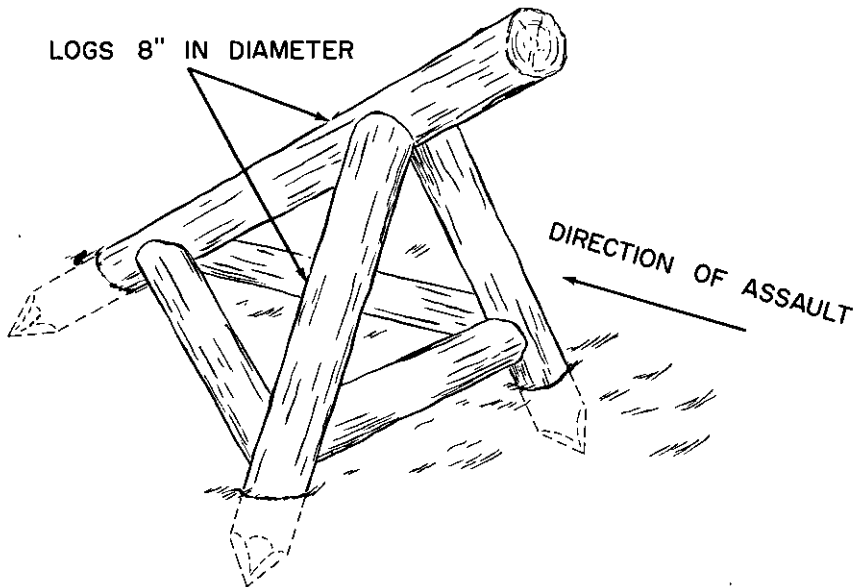

Figure 130. Braced wooden posts.



HEIGHT VARIES. OBSTACLE
SHOULD BE COVERED BY 1' TO 2'
OF WATER AT HIGH TIDE.

Figure 131. Log tripod.

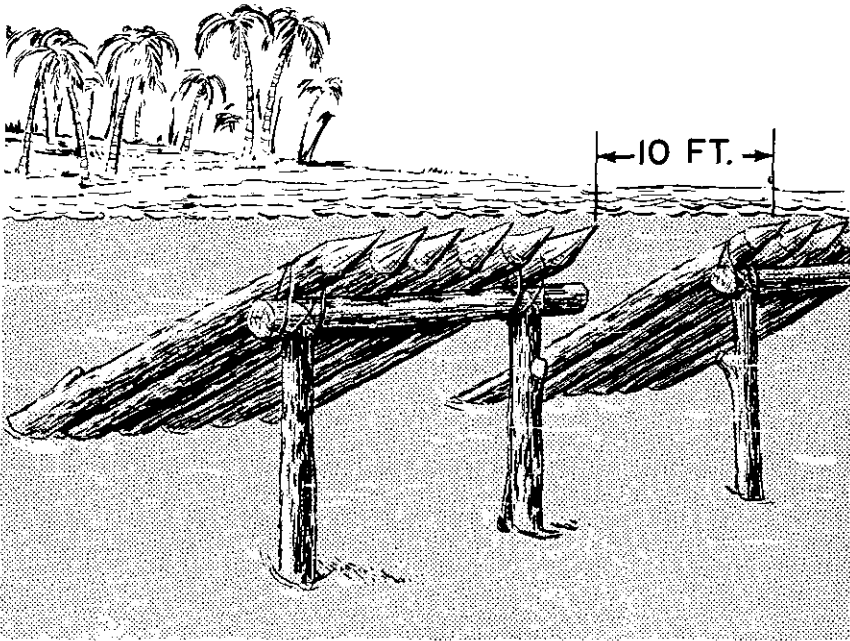

Figure 132. Log ramps.

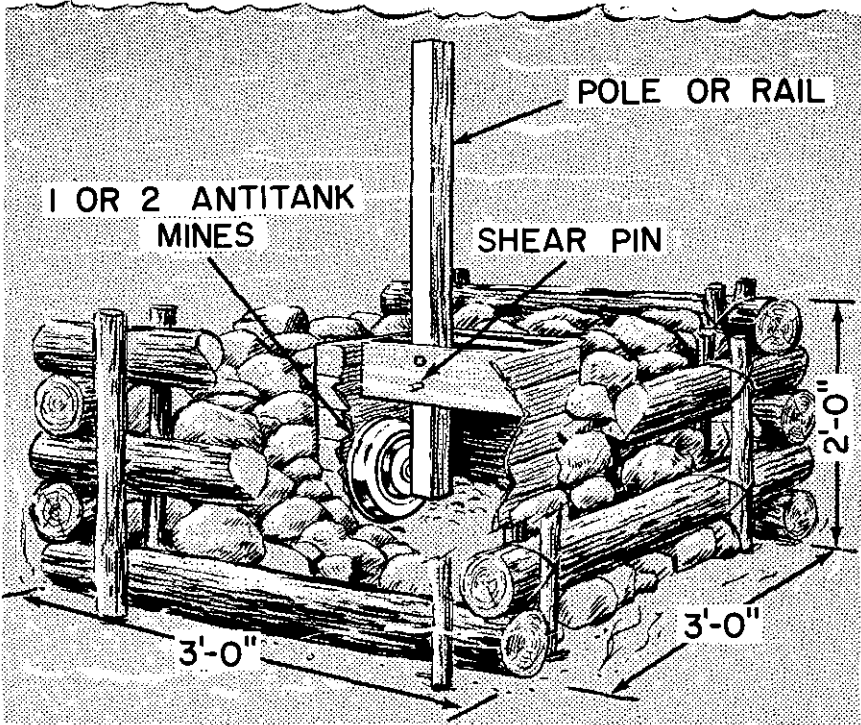

Figure 133. Nutcracker.

landing craft striking the pole will break or bend the shear pin sufficiently to detonate the mines. Nutcrackers are normally employed in an irregular pattern, interspersed with plain steel and log posts.

151. Steel Obstacles

Steel beams, piles, and rails provide simple and effective antiboat obstacles of the post type. Steel rails can be driven in rocky or coral bottoms in which wood piles would be splintered. Steel obstacles of portable types are advantageous for underwater use because of high unit weight of steel; they remain in position without anchorage against wave or currents. Steel obstacles intended for field fabrication for antiboat use include the following:

a. *Steel Scaffolding.* On beaches having considerable tidal range, 2-inch steel pipe may be driven into the bottom and welded together to form a structure of the scaffolding type, as shown in figure 134. Floating mines may be attached below the normal water level, to be detonated if scraped by a vessel.

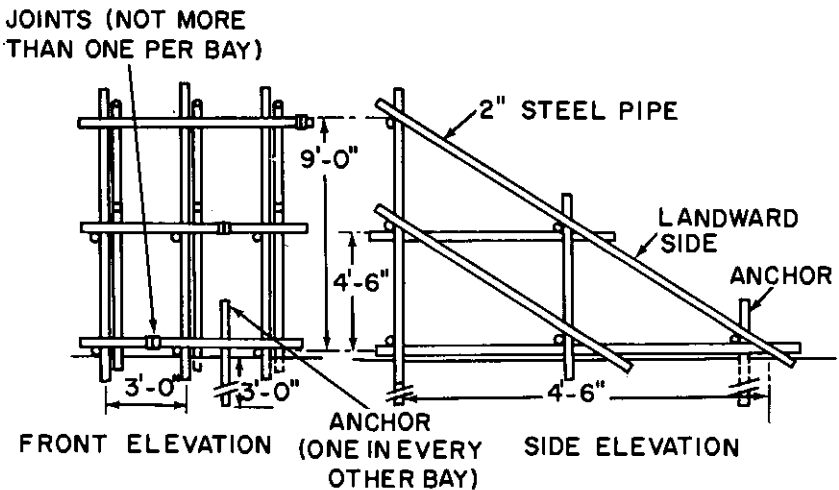

Figure 134. Steel scaffolding.

b. *Steel Hedgehogs.* Steel hedgehogs of the type shown in figure 135 are fabricated in rear areas, shipped knocked down, and quickly assembled with a bolted center connection. The angles used are usually about 6 feet long, making the obstacle about 4 feet high. The hedgehog is emplaced without anchorage so that it revolves under a boat or amphibious vehicle, holes it, and anchors it as it sinks. Normally hedgehogs are installed in several rows, using about 150 hedgehogs to each 100 yards of beach.

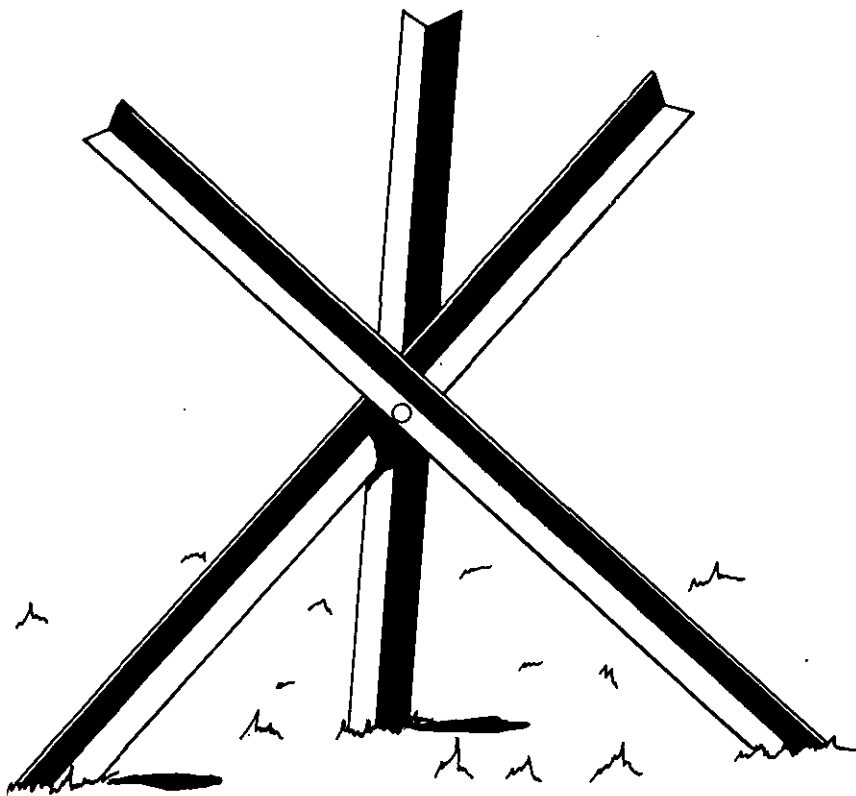

Figure 135. Steel hedgehog.

152. Concrete Obstacles

As with obstacles of other materials, all types of concrete obstacles described in paragraphs 142 through 144 may be used as beach obstacles under certain conditions. Concrete obstacles of post type are particularly useful if heavy piledriving equipment is available. Some types are improved for antiboat use by embedding rails in their tops to form horned scullies. The cylinder modified in this manner is shown in figures 136 and 137. By setting the rails at an angle of about 45° with the vertical, a fast-moving boat is holed and may be sunk as its momentum carries it down over the length of the horn. The horns may be improved by pointing them, using oxyacetylene cutting equipment.

153. Barbed Wire Beach Obstacles

Wire entanglements are used as antipersonnel obstacles but will also stop light landing craft. They are placed inshore of scaffolding or sunken obstacles and, if possible, are covered by machinegun fire. Entanglements normally are built at low tide. They require constant

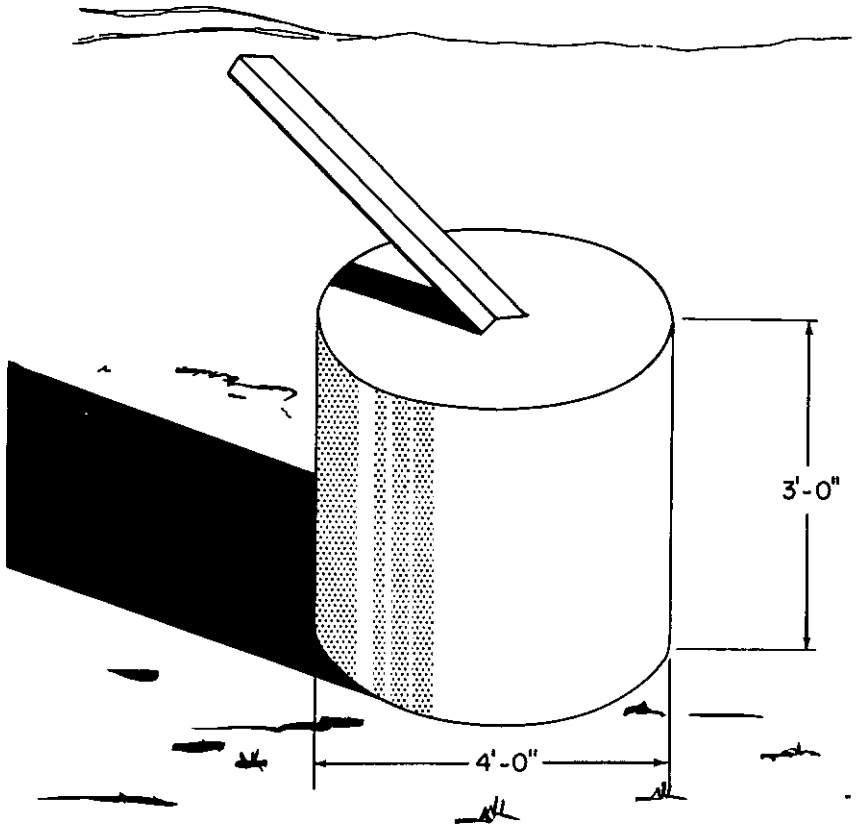

Figure 136. Horned scully based on concrete cylinder.

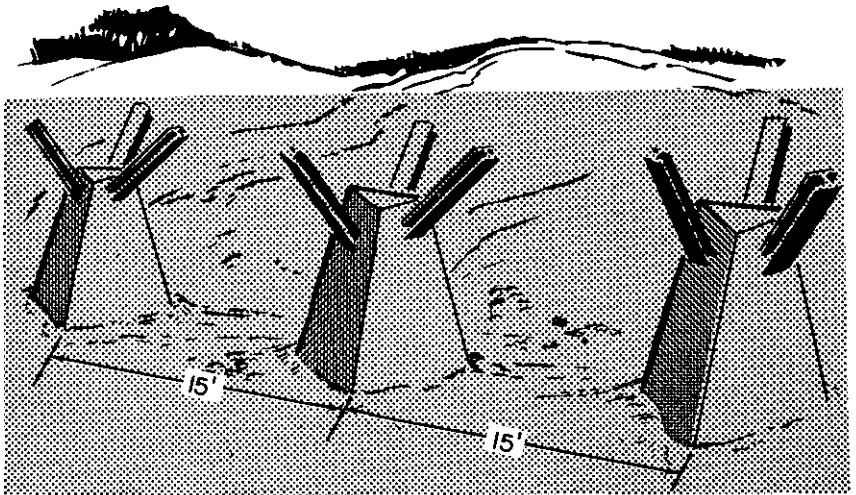

Figure 137. Horned scullies based on small dragon's teeth.

maintenance, particularly if placed in surf. Wire also is erected on beaches or river banks, often in connection with antitank and anti-personnel minefields. Almost all of the types of wire obstacles described in chapter 16 may be used in conjunction with other types of beach and underwater obstacles.

154. Expedient Underwater Obstacles

The obstacles described in *a* and *b* below are made with native materials, some supplemented with barbed wire, and are difficult to reduce. Wherever possible, mines should be used with the obstacles to increase their effectiveness and to hinder removal by enemy underwater demolition teams.

a. Rock Mounds. These consist simply of mounds of rock about 3 feet high and 12 feet square and staggered at intervals of 10 to 15 feet on the outer edges of reefs or likely landing beaches.

b. Rock Walls (fig. 138). Rock walls are about 4 feet high and from 3 to 4 feet wide, in sections or continuous lines. They should be mined and topped with concertinas. They should be sited so that the top of the wire is just under the surface at high tide.

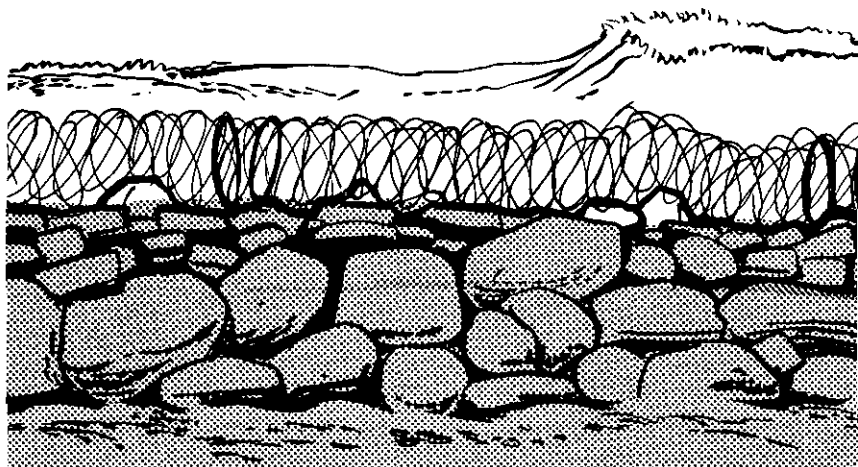

Figure 138. Rock walls.

APPENDIX I

REFERENCES

1. DA Pamphlets and Regulations

| | |
|-------------------|--|
| DA Pam 39-1 | Nuclear Weapons Employment |
| DA Pam 39-3 | The Effects of Nuclear Weapons |
| DA Pam 108-1 | Index of Army Motion Pictures, Film Strips, Slides and Phono Recordings |
| DA Pam 310-series | Military Publications Indexes |
| AR 320-50 | Authorized Abbreviations and Brevity Codes |
| AR 320-5 | Dictionary of United States Army Terms |

2. Field Manuals

| | |
|----------|---|
| FM 3-5 | Tactics and Techniques of Chemical, Biological and Radiological Warfare |
| FM 5-6 | Operations of Engineer Troop Units |
| FM 5-20 | Camouflage, Basic Principles and Field Camou- flage |
| FM 5-25 | Explosives and Demolitions |
| FM 5-31 | Use and Installation of Boobytraps |
| FM 5-34 | Engineer Field Data |
| FM 5-35 | Engineers' Reference and Logistical Data |
| FM 7-100 | Infantry Division |
| FM 20-32 | Land Mine Warfare |
| FM 21-5 | Military Training |
| FM 21-6 | Techniques of Military Instruction |
| FM 21-10 | Military Sanitation |
| FM 21-26 | Map Reading |
| FM 21-30 | Military Symbols |
| FM 21-40 | Small Unit Procedures in Atomic, Biological, and Chemical Warfare |
| FM 23-55 | Browning Machineguns, Caliber .30 M1917A1, M1919A4, M1919A4E1, M1919A6, and M37 |
| FM 23-65 | Browning Machinegun, Caliber .50 HB, M2 |
| FM 24-20 | Field-Wire Technique |
| FM 30-5 | Combat Intelligence |
| FM 31-10 | Barriers and Denial Operations |
| FM 31-50 | Combat in Fortified Areas and Towns |
| FM 31-60 | River-Crossing Operations |

| | |
|-----------|--|
| FM 31-72 | Mountain Operations |
| FM 72-20 | Jungle Operations |
| FM 100-5 | Field Service Regulations; Operations |
| FM 100-10 | Field Service Regulations; Administration |
| FM 101-5 | Staff Organization and Procedure |
| FM 101-10 | Organization, Technical, and Logistical Data |

3. Technical Manuals

| | |
|-----------|---|
| TM 3-350 | Improvised CBR Protective Shelters |
| TM 5-226 | Carpentry |
| TM 5-252 | Use of Road and Airfield Construction Equipment |
| TM 5-260 | Principles of Bridging |
| TM 5-286 | Semipermanent Highway and Railway Trestle Bridges |
| TM 5-302 | Construction in the Theater of Operations |
| TM 5-310 | Military Protective Construction |
| TM 5-360 | Port Construction and Rehabilitation |
| TM 5-725 | Rigging |
| TM 9-1910 | Military Explosives |
| TM 9-1940 | Land Mines |
| TM 9-1950 | Rockets |
| TM 9-1980 | Bombs for Aircraft |
| TM 9-2800 | Military Vehicles |
| TM 23-200 | Capabilities of Atomic Weapons (U) |
| TM 30-246 | Tactical Interpretation of Air Photos |

4. Training Circulars

| | |
|--------|---------------------------------|
| TC 5-8 | Atomic Demolition Munitions (U) |
|--------|---------------------------------|

APPENDIX II

FORTIFICATION PROTECTION FACTORS

1. Purpose

a. Fortification Protection Factors (FPF's) provide a method of determining, within specified limits, the relative value of field fortifications. The primary purpose of FPF's is to give simple meaningful numbers for comparison of the protection afforded by different fortifications against nuclear weapons. The use of FPF's does not require detailed nuclear weapons effects training, classified data, or the use of graphs, monographs or templates.

b. Fortification Protection Factors are not substitutes for detailed weapons effects analysis where such analysis is practical. They are designed for a hasty evaluation of the relative protection afforded by different fortifications. This protection is measured against for protection (or lack of protection) of personnel in the open. The FPF method is not designed to give specific numbers of casualties from a specific weapon, although it can be used for this purpose as a rough approximation.

2. Definition

a. *General.* The Fortification Protection Factor (FPF) of any fortification can be very simply defined as a measure of the chance of injury to a man in the fortification from a nuclear burst in his vicinity compared to the chance of injury to a man in the open at the same place. FPF's are based on the size of the area in which the ground zero of a nuclear burst must lie in order to have at least a 50 percent probability of causing injury to a person in the center of the area. This area is equal to the area of damage (πR_1^2) for the weapon and effect in question. The FPF of any fortification is determined by the ratio of the areas of damage for protected and unprotected troops for the same weapon and conditions. However, there is a single FPF for each fortification throughout a wide range of conditions. The ratio of damage areas is always less than one; therefore, to avoid use of fractions, it is multiplied by 100, and FPF's are always between 0 and 100, with most greater than 20. The greater the FPF of a fortification, the less the protection afforded. An FPF of 100 indicates no protection, and is the FPF of a man in the open. Lower FPF's indicate a lower probability of injury, and thus a higher degree of protection. A man in a fortifica-

tion with an FPF of 40 has half the chance of injury of a man in a fortification with an FPF of 80, under similar conditions.

b. Specific. Specifically, the FPF of a fortification is equal to 100 times the probability that a man in the fortification will receive at least a given level of effects from a randomly delivered weapon which, if he had been in the open, would have inflicted upon him at least the same level of effects. Figure 139 presents this schematically. Under specific conditions of air density, height of burst, terrain, and weapon design, a burst of a given yield has at least a 50 percent probability of inflicting at least a specific damage level upon a man in the open at a point P, if the ground zero is anywhere in Area A. Under the same conditions, this same burst has at least a 50 percent probability of inflicting at least the same specified damage level upon a man in a specific fortification at P if the ground zero is anywhere in Area B. The relative probability of sustaining the specified injury in the protected or unprotected condition is the ratio of Area B to Area A, and the FPF of the fortification is equal to $100 \times \frac{\text{Area B}}{\text{Area A}}$. Area A is determined by the radius of damage for a man in the open for the weapon and conditions given. Area B is determined by the radius of damage for a man in the fortification for the same weapon and conditions. Therefore:

$$\text{FPF} = 100 \times \left[\frac{R_{D \text{ protected}}}{R_{D \text{ unprotected}}} \right]^2$$

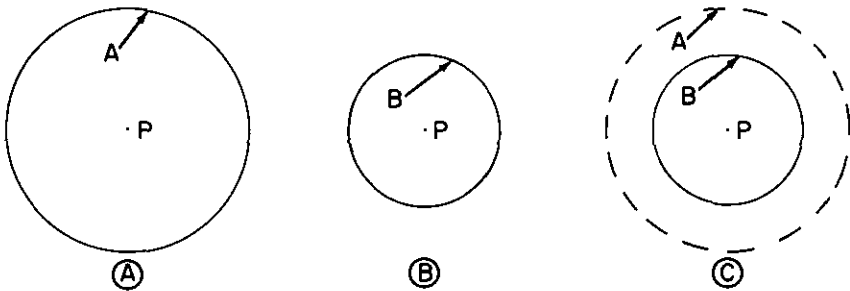

- 1 Area A is the area in which ground zero of specific weapon must lie to have at least a 50 percent probability of causing at least a specific level of damage to a man in the open at Point P.
- 2 Area B is the area in which ground zero of the same weapon under the same conditions must lie to have at least a 50 percent probability of causing at least the same level of damage to a man in a specific fortification at Point P.

- 3 Comparison of Areas A and B. $\text{FPF} = 100 \times \frac{B}{A}$

Figure 139. Schematic determination of a fortification protection factor.

3. Discussion

a. General Application. Fortification Protection Factors are designed to give to fortifications a rating of their comparative worth in protecting personnel against nuclear effects, and are particularly appro-

priate for those individuals who have had no detailed nuclear weapons training, for those units which do not have nuclear weapons specialists, and for those units whose nuclear weapons specialists are too concerned with weapons employment to analyze constantly changing specific individual and unit positions.

b. Application to Individuals.

- (1) The use of FPF's is particularly advantageous because it indicates protection in terms of relative probability of not being injured, rather than in terms of pounds of blast pressure per square inch or radiation transmission factors, both of which are easily defined but difficult to relate to protection. For example, a prone shelter has a gamma radiation transmission factor of 0.4 and a neutron transmission factor of 0.7. A foxhole has a gamma transmission factor of 0.1 and a neutron transmission factor of 0.3. How much "better" is the foxhole than the prone shelter? To answer these questions, the corresponding transmission factors might be subtracted or divided, but the result has no concrete meaning. To obtain an answer in terms of numbers of casualties or probability of casualties, such an answer must be determined from nuclear weapons manuals as it applies to the specific situation. On the other hand, using FPF's, the problem becomes simpler. The average FPF of a prone shelter is 85, and the average FPF of a foxhole is 65. Therefore, the man in the foxhole is about 75 percent ($65/85$) less "vulnerable" than the man in the prone shelter at the same location.
- (2) Table VI lists not only the FPF for standard fortifications but also the man hours and logistic effort for average construction conditions. This information allows an evaluation of protection afforded (in terms of FPF's) compared to the effort required to attain that FPF. For example, it takes approximately $1\frac{1}{2}$ hours for two men to construct an open two man foxhole with an FPF of 65. It will take these men at least 4 hours to add a half covered section and an adjoining shelter, giving an FPF of 30. The decrease in chance of injury in this position, as compared with the open foxhole, is significant, but the effort required is great. Is the effort, plus the exposure while digging, and the lack of rest worth the added protection? This may depend on how long the unit will stay there. As always, such a question is a command decision, but the two most important factors required for the answer, which are protection afforded and effort required, are tabulated in table VI.

c. Application to Units.

- (1) The previous paragraph showed that decreasing FPF from

100 to 65 (a decrease of 35) requires an effort of 3 man-hours. Another decrease of 35 (from 65 to 30) requires an effort of at least 8 man-hours. Thus, less value is gained from effort expended at higher levels of protection (low FPF) than from effort expended at lower levels of protection (high FPF). In a unit, therefore, more overall protection is achieved by concentrating effort on low level protection for all troops than high level for a few.

- (2) The disposition of troops of any unit in the combat zone is constantly changing. Each new situation presents new possibilities for dispersion, digging in and layout of units. Consider, for example, a battle group position in which one fifth of the troops are in prone shelters, two fifths in open foxholes, one fifth in half covered foxholes or their equivalent, and one fifth in the open. The battle group has been halted for a few hours, and now the halt has been extended. The Battle Group Commander has several alternate courses of action. The first alternative is to maintain the present disposition so as to give as many people as possible time to rest and work on their equipment. A second alternative is to improve the physical protection of the unit by putting maximum effort on "digging in," including extensive use of requisitioned and expedient fortification materials. A third alternative is to spread out the unit, and thereby reduce the possible casualties. The first alternate course of action will not provide better protection but will increase the unit's combat capability; providing no nuclear or conventional weapons have been used against the unit in the meantime. The second alternate course of action provides more physical protection but requires strenuous manual effort and considerable logistic support. The third alternate course of action combines relative ease with relative safety but may be impossible to achieve because the mission cannot be accomplished in a more dispersed position, or because the presence of other units may prohibit dispersion. In addition, dispersing may make useless many of the positions already constructed. In order to evaluate these alternatives, the Battle Group Commander needs some means to compare them with one another. He particularly needs to know if he is getting his money's worth from digging in. A nuclear weapons specialist could estimate, for the fortifications used, the blast resistance in pounds per square inch for various levels of protection. Thus, the increase in blast resistance as the fortifications are improved can be calculated. If the additional protection afforded by the additional blast resistance is calculated in terms of the effective reduction of the area of

damage of a given weapon, (which is considered the most logical way to measure such protection) then the increase of blast resistance expressed in terms of pounds per square inch is of little value. This is because the reduction in area of damage to such an increase in blast resistance varies greatly with the range of overpressure in which the increase takes place. This is shown in the following table for a 50 KT surface burst:

| <i>Peak overpressure</i> | <i>Radius of damage</i> | <i>Area of damage</i> |
|--------------------------|-------------------------|-----------------------|
| 10 psi | 1,120 m | 3.9 km ² |
| 20 psi | 810 m | 2.1 km ² |
| 30 psi | 650 m | 1.3 km ² |
| 40 psi | 610 m | 1.2 km ² |

The same reasoning applies to measuring the increase of protection by reduction of radiation transmission factors. Nevertheless, the nuclear weapons specialist could estimate, based on the disposition of the unit and for a given weapon detonated at a given height of burst over a given ground zero, how many casualties may be expected. However, for several different weapons, different heights of burst, different ground zeroes, and different dispositions, a great many computations will be required.

- (3) On the other hand, using FPF's, the commander may be informed that, generally speaking, a man in a prone shelter has only 85 percent of the probability of being injured as compared to a man in the open, a man in an open foxhole has only a 65 percent probability of similar injury, and a man in a half covered foxhole only a 55 percent probability. With the unit's current disposition and considered only from the aspect of fortifications, the unit as a whole is about 75 percent as vulnerable as it would be if it were completely unprotected. (The actual weighted average of the FPF's for the disposition given is 74 percent.) These figures are average figure, and irregularities in the dispersion of troops can result in a nuclear burst causing more or less percent of casualties than the FPF indicates.
- (4) Assume that the Battle Group Commander's staff estimates that, with the manpower available, in six hours time the Battle Group will have approximately one fifth of its members in open foxholes, one fifth in half covered foxholes, one half in half covered foxholes with adjoining shelter and one tenth in the open. At this time, considering only fortifications, the unit will be about 50 percent as vulnerable as it would be in the open with the same dispersion. (The actual weighted average of the FPF's in this case is 49 percent.) *If the com-*

mander decides to bolster his protection by improving his fortifications, it will take six hours of work and considerable materiel to reach an average FPF of 50, which is equivalent to decreasing the average of probability of injury to each man in the unit by 67 percent (50/75) from his present situation. The unit commander could achieve this same increase in protection for his people, in terms of numbers of casualties from the same weapon, by dispersing his unit into an area one and a half times as large. This is probably easier than digging for six hours but the requirements of the mission and the location of other units may prevent it. The commander may not wish to risk the additional exposure of his unit during the actual dispersal. Under such circumstances, the use of average FPF's gives the commander a rough but convenient guide against which to compare possible courses of action.

d. Effect of Variables. In the calculation of fortification protection factors, it can be shown that, within reasonable limits, variations in the factors listed below cause no significant variations in the FPF. The primary reason for this is any increase or decrease in range of effects caused by changes in these factors is offset by a corresponding increase or decrease in range of effects upon a protected individual. Furthermore, compared to the radius of damage, the effect of many of these variables is small. Thus the ratio of $\left[\frac{R_D \text{ protected}}{R_D \text{ unprotected}} \right]^2$ remains relatively constant.

- (1) Yield. Below 1 KT, FPF's tend to increase; above 500 KT they tend to decrease. Between these yields, FPF's can be considered relatively constant for each fortification. The range of yields considered covers those weapons most likely to be used tactically against protected troops.
- (2) Type of weapon. Weapons type influences neutron flux. Radii of damage for both protected and unprotected troops will increase or decrease proportionately with increase or decrease of flux for the same level of effects.
- (3) Height of burst. At those ranges of radii of damage at which survival appears likely, variations in height of burst affect protected and unprotected troops about the same. Fortification configuration will cause some variations in this, but since ground zero and height of burst of an enemy weapon cannot be predicted, the tabulated FPF's are an average for all reasonably probable heights of burst and fortification orientations.
- (4) Distance from ground zero. This factor will not affect the FPF of a fortification as defined.

- (5) Weather and terrain. These factors will affect weapons effects on protected and unprotected personnel about equally, and will not affect the FPF's as defined.

e. Reliability. The FPF's shown in table VI are based on the data contained in appropriate weapons effects publications. Such data are at best subject to 20 percent error. In evaluating transmission radiation factors and blast pressure resistance of fortifications, additional errors are introduced due to the inexact state of the art in determining these factors. Thus FPF's are far from being precise measures. Nevertheless, they do present a good picture of the relative protective value of various shelters emplacements.

4. Criteria For Effects Levels

a. The level of effects over which FPF's were calculated range from those presenting a minor nuisance value to those which might cause as many as 50 percent of the troops to become ineffective. FPF's are not recommended for use in weapons employment, unless they have been evaluated at the desired levels of effects.

b. To calculate FPF's for various fortifications, radii of damage for numerous combinations of yield, air density and effects levels were compared against the protection offered by each fortification. The yields of weapons used ranged from 1 to 100 KT. The relative air densities used ranged from 0.8 to 1.0. The prompt radiation effects levels used ranged from 20 to 200 rem for combined prompt gamma rays and neutrons. The blast effects used ranged from "light" to "moderate" damage as defined in current nuclear weapons effects manuals, with these limits assumed to correspond with 20 to 200 rem respectively. The overpressures at which specific fortifications receive specific damage levels (light or moderate) vary with fortification design, soil type and condition, and revetment used. These variables could not all be used in calculating FPF's so average blast resistances based on fortification type were used.

c. Thermal radiation has not been considered in determining FPF's because of the many variables which influence the effect of thermal radiation on personnel, such as visibility, clothing type and thickness, time of day, incidental shadowing and weapon yield.

d. Because residual radiation is a time dependent effect and is not always present in quantity in nuclear detonations, it was not used in computing FPF's. Residual radiation transmission factors and a simple categorization of protective value from residual radiation are listed in the tables which describe the characteristics of the various emplacements (tables VI, VII, and VIII).

APPENDIX III

ILLUSTRATIVE EXAMPLES OF INSTALLATIONS DISPERSAL

1. General

a. This appendix contains the calculations and diagrams for the examples of the three types of installations discussed in chapter 6.

b. The design weapons for these examples were 200 KT, 1 MT and 5 MT. Three levels of protection were considered—that for personnel in the open, not subject to thermal effects; that for personnel in foxholes which gave them protection from blast pressures up to 15 psi, a level which is assumed to be the average which the supplies and equipment can withstand without receiving more than light damage; and that for personnel in shelters and equipment in trenches, which is assumed to be 25 psi for no more than light damage. Each of the effects radii corresponding to these effects was multiplied by 1.3 to give less than a 10 percent probability of exceeding the prescribed limits. The resultant damage radii are shown in the table below.

| | Yield | | |
|--|---------|---------|----------|
| | 200 KT | 1 MT | 5 MT |
| Personnel in open..... | 2,900 m | 5,500 m | 10,400 m |
| Personnel in foxholes..... | 2,000 m | 3,300 m | 5,800 m |
| Personnel in shelters, supplies and equipment in trenches. | 1,500 m | 2,600 m | 4,300 m |

At the ranges shown in the preceding table, nuclear radiation damage is not significant, if the personnel are protected as shown.

c. The principle of dispersion in each example is to separate similar activities sufficiently so that the design nuclear burst does not destroy more than a specified percent of the overall capability represented by any type activity. For these examples, the maximum allowable loss per design weapon will be one-third of any specific capability. This is only possible if the units representing each capability can be divided into at least three physically separated parts. In some cases this will not be possible without an unacceptable loss in efficiency.

2. Linear Installation Layout

a. *General.* This paragraph gives an example of a linear installation layout as discussed in paragraph 29. The three levels of protection described in paragraph 1b, this appendix, will be considered. The installation is assumed to be one containing packaged supplies, suitable for open storage. The design weapon is one megaton. Figure 140 illustrates the layout of the installation.

b. *Spacing.*

- (1) Supplies are left in the open, but maximum advantage is taken of natural terrain features for protection. In order to reduce overall length, personnel are provided with foxholes. The distance between like supplies in each subinstallation

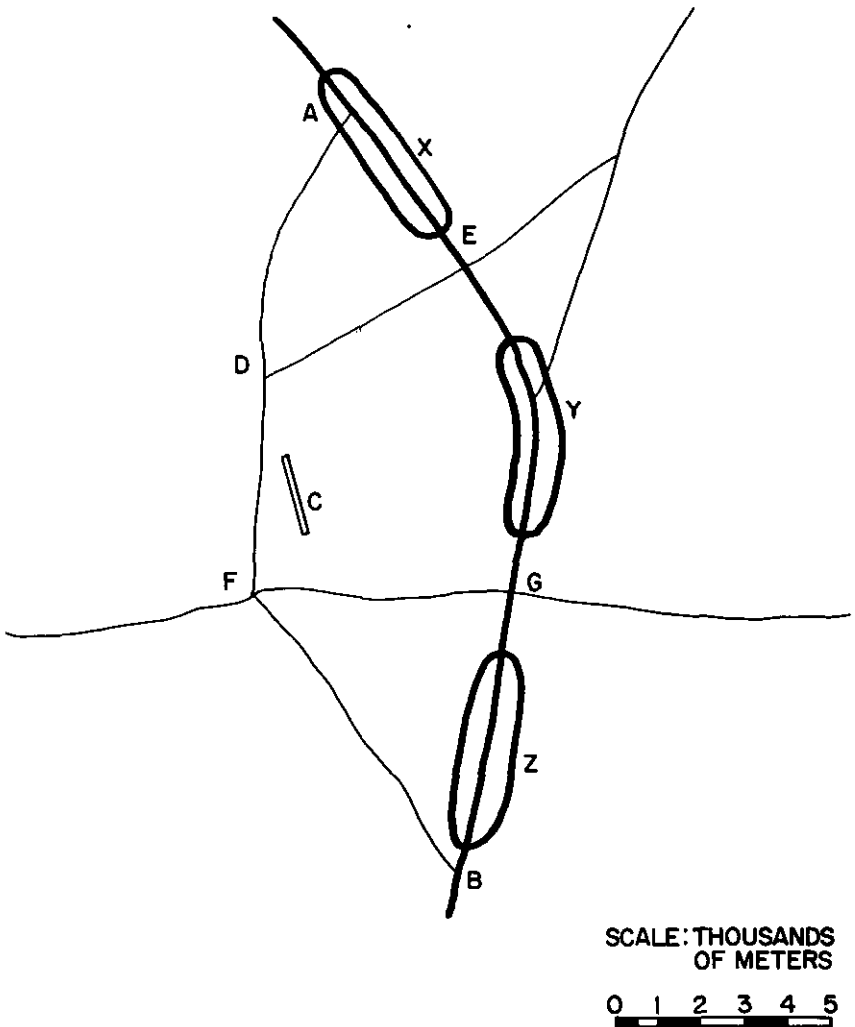

Figure 140. Linearly dispersed installation layout.

should then be at least twice the appropriate radius of effects, or 6,600 meters.

- (2) The subinstallations themselves are large enough to consider some allowance to be made for their length. A reasonable allowance is to measure the separation distance (6,600 meters in this case) from the center of one subinstallation to the near edge of the next. However, this added distance might be unacceptable because of the total length it adds to the overall installation. By placing like supplies in the same relative position in each subinstallation, the necessity for this added distance may be avoided. In this case, similar layouts in each subinstallation are assumed, so no extra safety distances are needed. Therefore, the center to center distance between subinstallations will be 6,600 meters for the level of protection assumed.

c. Layout. For the installation shown in figure 140, road AB is chosen as the axis of the supply point. Subinstallation areas X, Y, and Z are laid out as shown, each having a similar distribution of supplies. Not only is the distribution of supplies to these subinstallations similar, but their area of location within the subinstallations is generally similar. In this way, if a nuclear weapon strikes between two subinstallations, the portions of each remaining when combined will still have a balanced distribution of supplies. An airstrip at C is available to all three subinstallations. A route from A or E to D to F to B or G is available over secondary roads to permit bypassing Y if a nuclear strike there blocks the main road. The overall length of the installation is 18 kilometers. This is long for a single installation but is 10 kilometers shorter than the installation would be if the personnel were unprotected. On the other hand, if equipment trenches and personal shelters were available, the overall length could be reduced to 14 kilometers.

3. Point Dispersed Installation

a. General. This illustrative example is for a small installation well forward as discussed in paragraph 30. The installation (fig. 141) is not large enough to be able to disperse to the extent required for a megaton weapon and still accomplish its mission with reasonable efficiency. It is decided, based on location of the supply point and on knowledge of enemy capabilities and policy, to plan to protect the installation against a large tactical atomic weapon, such as one of 200 KT yield. The three levels of protection described in paragraph 1b of this appendix will be considered. Only simple, rapidly accomplished protective measures will be taken; these may include construction of shallow trenches and revetments for protection of certain supplies and equipment, the construction of small, simple, timber or corrugated metal cut and cover shelters for personnel, or the use of foxholes. If any existing protective shelter can be found it will be used.

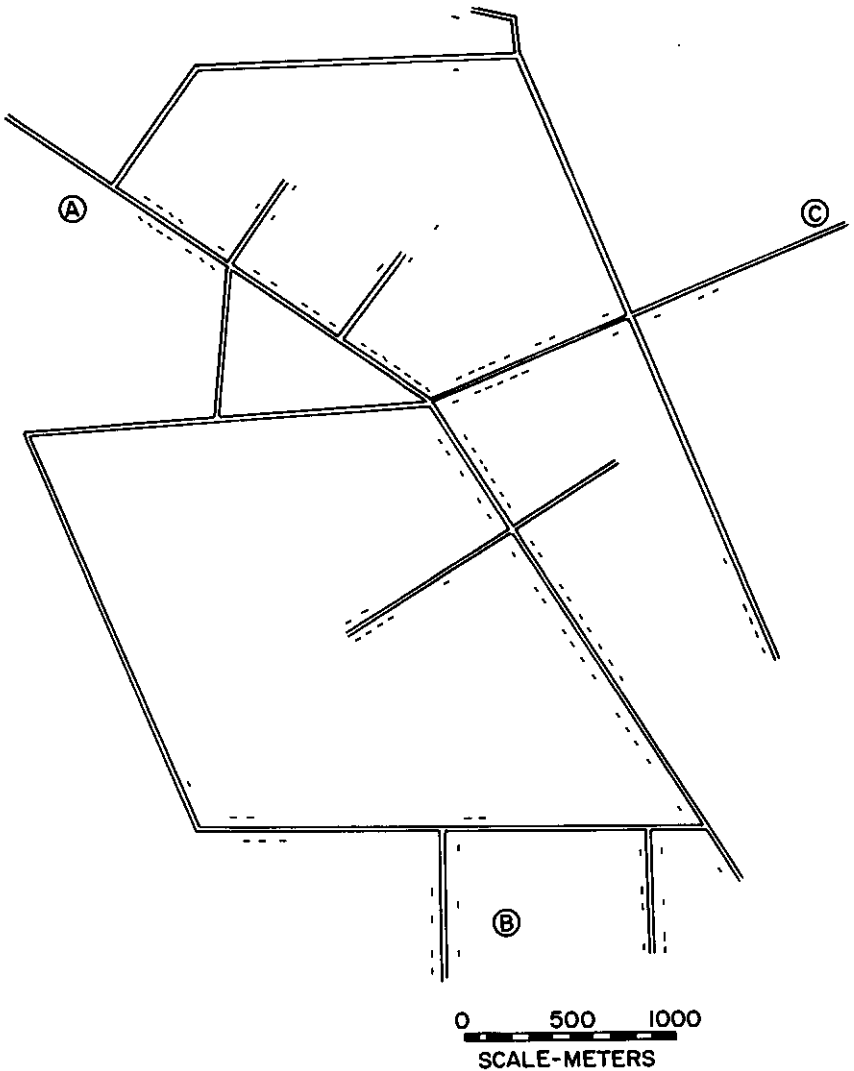

Figure 141. Point dispersed installation layout prompt.

b. Composition of Installation. In this installation there are three categories of facilities and supplies.

- (1) Facilities such as transient parking, salvage storage, etc., for which protection will not be afforded. These facilities will be located as is most convenient with respect to other facilities and as required by camouflage and deception requirements.
- (2) Certain supplies which are available on local procurement, and are not in critical shortage. They are of sufficient importance to the mission of the supply point to warrant protection but re-supply time and effort are relatively small. For these items, in

the interests of minimum fragmentation of stocks and consequent loss of operating efficiency, a subdivision of stocks into two parts is deemed adequate.

- (3) For the remainder of the supplies, it is determined that a subdivision of stocks into three parts is necessary to insure that sufficient stock will remain after an attack to permit the supply point to continue its mission until resupply is accomplished.

c. Results of One Weapon Attack. From the analysis of the general location assigned, three points (A, B, C) are chosen for development (fig. 141). Foxholes for personnel and trenches for fragile supplies are planned, so the points are 4,000 meters apart. This will insure that at least two of the three points remain operable, or at least are rapidly recoverable after a 200 KT burst. Figures 142 and 143 illustrate the effect of a 200 KT burst aimed at the crossroads in the center of town with a 200-meter delivery error. As shown in figure 142, the personnel at site A would receive an initial radiation dose in excess of the design dose—although it would not be lethal. The fallout radiation (fig. 143) would be very small in this area compared to the initial gamma received but the additive effect of both would increase casualty-producing effects slightly. No other serious damage would occur to protected personnel or equipment. Unprotected supplies may be lightly damaged in varying proportions in the three subinstallations, but would not be severely damaged. Unprotected personnel would receive excessive initial radiation doses of over 2,000 meters—enough that some of the personnel would be casualties, especially with the added fallout dose (unless they promptly got in shelters). Vehicles, even unprotected, would receive only moderate damage at a little over 2,000 meters. From this it can be seen that unprotected personnel in the entire supply point would probably be casualties, either delayed or prompt, but that any material damage other than to vehicles would be light. By referring to figure 143 it can be seen that limited operations without special purpose equipment could begin again at subinstallations A and C, fairly soon after the burst. Subinstallation B is in the path of heavy fallout. The foxholes at B will not provide adequate protection without immediate measures to provide overhead earth and to keep the fallout from dropping into the foxholes. Temporary evacuation of personnel should be considered.

d. Layout Modifications. By construction of personnel shelters and trenches for almost all the supplies, the distance between points may be reduced to 3,000 meters. This reduction in distance may not be significant in some cases. On the other hand, if no protection were available for the personnel, the points should be spread to 5,800 meters distance apart to insure the required survival. This is a significant increase in distance. The amount of stockage may be small enough, and alternate sources of supply may be sufficiently available, to allow supplies to be left in the open while the personnel receive high level protection. Then,

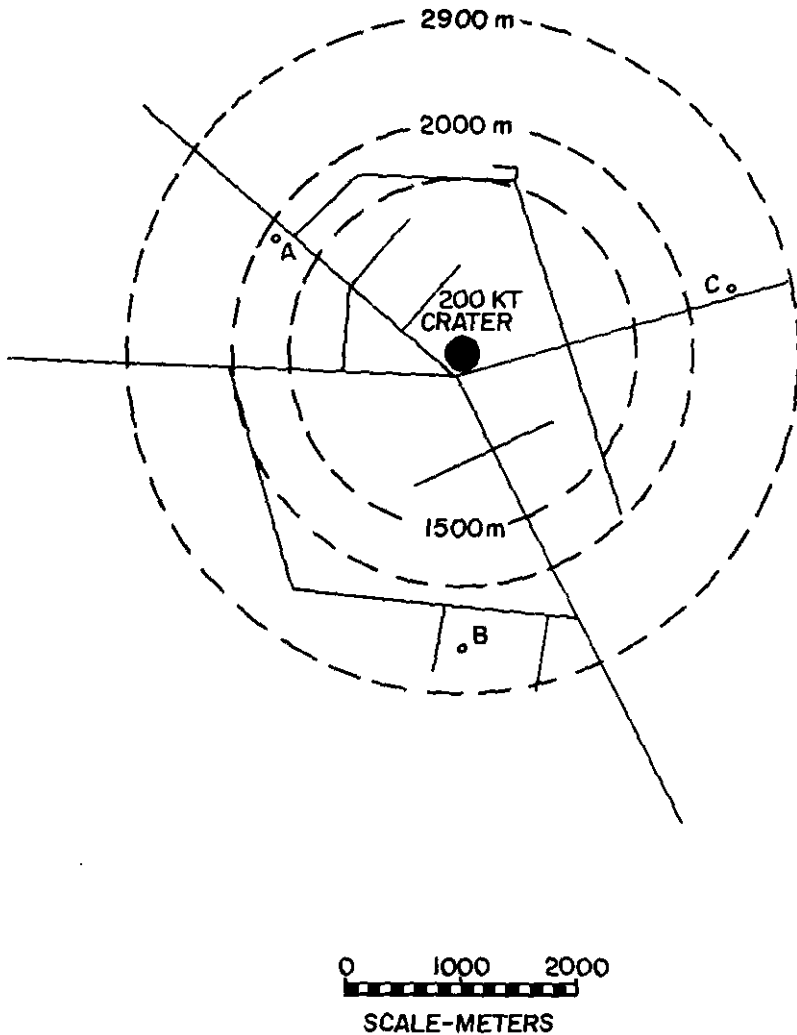

Figure 142. Effects of 200 KT weapon burst on a point dispersed installation.

after a nuclear attack and destruction of the supplies, resupply may be quickly accomplished and the activity put back into operation.

e. Superimposition. Another method of increasing efficiency of utilization of facilities and administrative operations, and of providing increased local security, would be to group several types of supply points or maintenance units, each subdivided among the subinstallations A, B, and C. This would increase the destruction which one weapon could do in terms of men and amount of supplies, but would not increase the proportion of any type of activity the weapon would destroy. There would always be at least two-thirds of any supply point or maintenance facility operable, and in general, for a 200 KT weapon, at least one of the

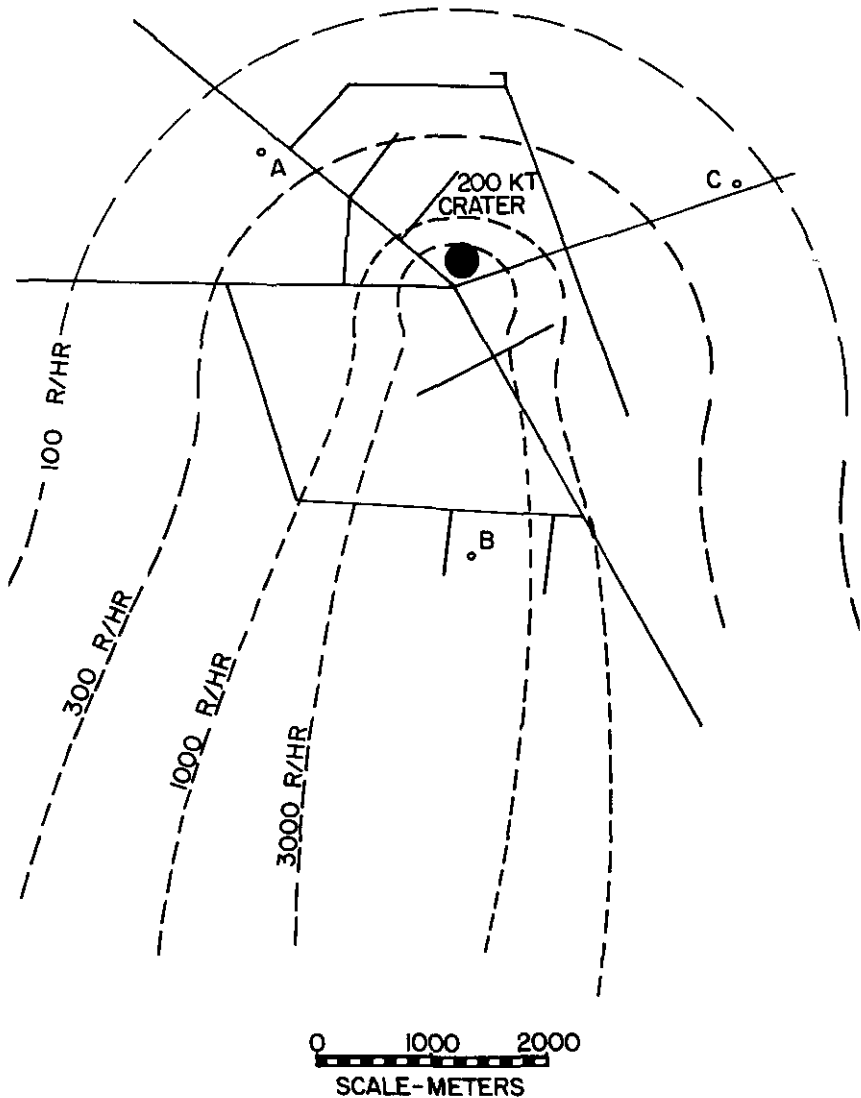

Figure 143. Residual radiation contamination resulting from 200 KT weapon burst on a point dispersed installation.

two remaining installations would be in an area of fallout light enough to permit resumption of activities on a limited shift basis within a day after the burst. An installation of this type is essentially an area dispersed installation.

4. Area Dispersed Installation

a. General. This paragraph gives an example of an area dispersed installation such as is discussed in paragraph 31. For simplification, three levels of protection will be considered as indicated in paragraph 1b of this appendix.

b. *Overall Layout.* Figure 144 represents the area around city M. This region is served by an excellent communications net and indigenous labor resources are assumed good. In accordance with operational and area limitations in the communications zone, it is desired to locate in this area a general depot, a replacement battalion, and a hospital area. M itself, being a communications center, appears to be a possible target for enemy atomic weapons. A circle of about a 500-meter radius includes those areas of M likely to be used as an aiming point for enemy atomic weapons. Intelligence indicates enemy delivery systems have a CEP (circular error probable) permitting them to have a 90 percent probability of coming within 600 meters of the aiming point. This gives a buffer distance of 1,100 meters to add to the minimum safe distances of paragraph 1 in determining how far from the center of M it is desirable to put different subinstallations. This indicates that from the center of M troops in the open should be 11,500 meters away, troops in foxholes should be 6,900 meters away, and troops in shelters and supplies in trenches should be 5,400 meters away. The insertion of this buffer distance, however, permits the use of four rather than three subinstallations around the perimeter without permitting loss of more than one to the prompt effects of a given blast. The prevailing wind (assumed) is from the south southwest.

c. *Subinstallation Location.* Subinstallation areas are as shown on figure 144 and are indicated by the letters W, X, Y, Z. This grouping permits maximum utilization of existing facilities. Distribution of facilities for the general depot is decided as follows: Efficiency will not permit fragmentation of all activities into four parts. Satisfactory distribution of stocks, however, can be made for the more important items by storing reserve stocks at each of two locations, and conducting normal issue and receiving operations at two other sites. In this case, sites W and X have the best transportation facilities, the most available natural camouflage in terms of orchards and light woods, and are in sufficiently populated areas and are sufficiently accessible to M to provide adequate indigenous labor easily. Also, in view of the prevailing winds, X is the most favorably located site with respect to probable fallout from a surface burst. W is located slightly less favorably than Y, and Z is worst of all. Therefore, the following layout of the general depot is decided on in order to minimize construction effort and maximize protection and efficiency. Subinstallations at Y and Z will consist of storage facilities for reserve stocks of those items of sufficient importance or criticality that substantial losses of stocks would have a marked impact on the depot's capability to support the assigned units. Issue and receiving activities for these items, and minimum working stocks will be maintained at two sites, X and W. Items of less consequence to the theater mission will be issued, received, and stored at these two sites only. Certain types of supply and maintenance facilities will be

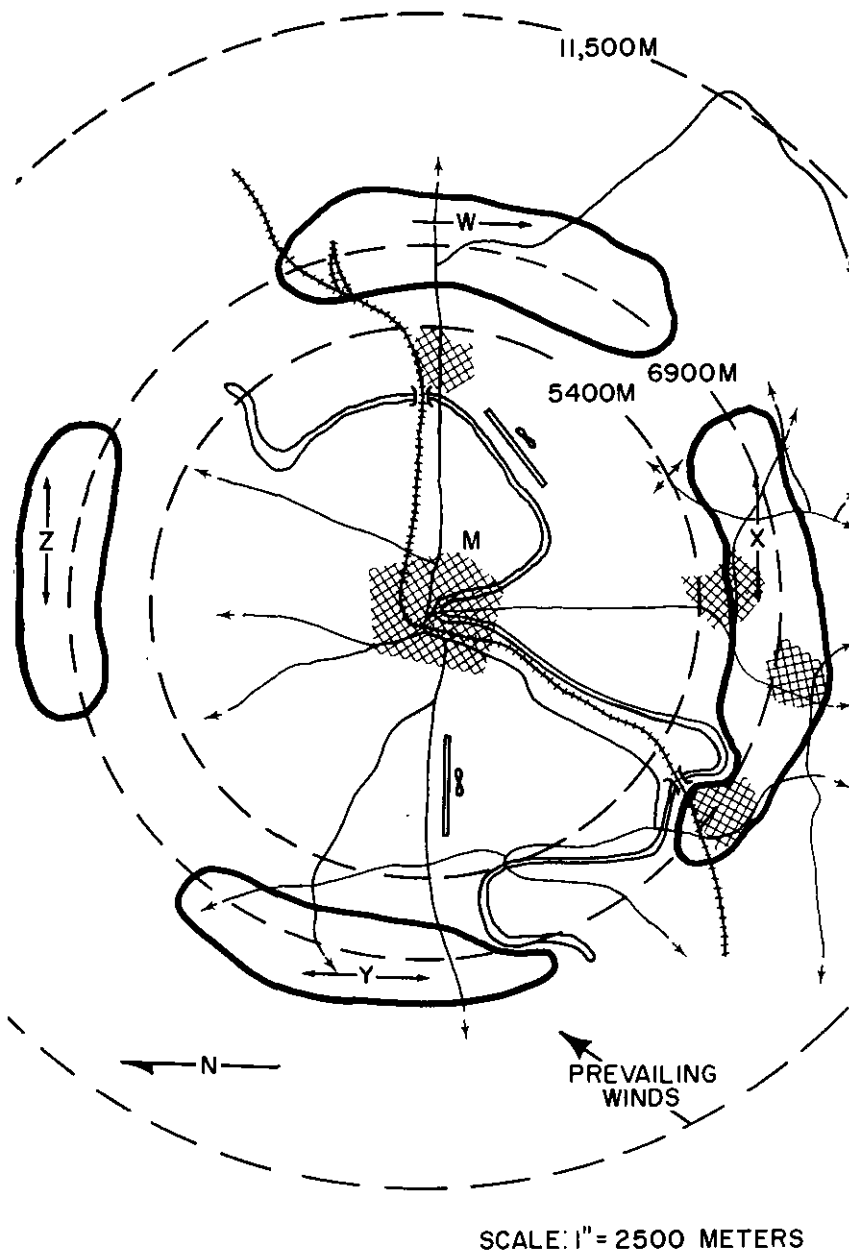

Figure 144. Vicinity of City M.

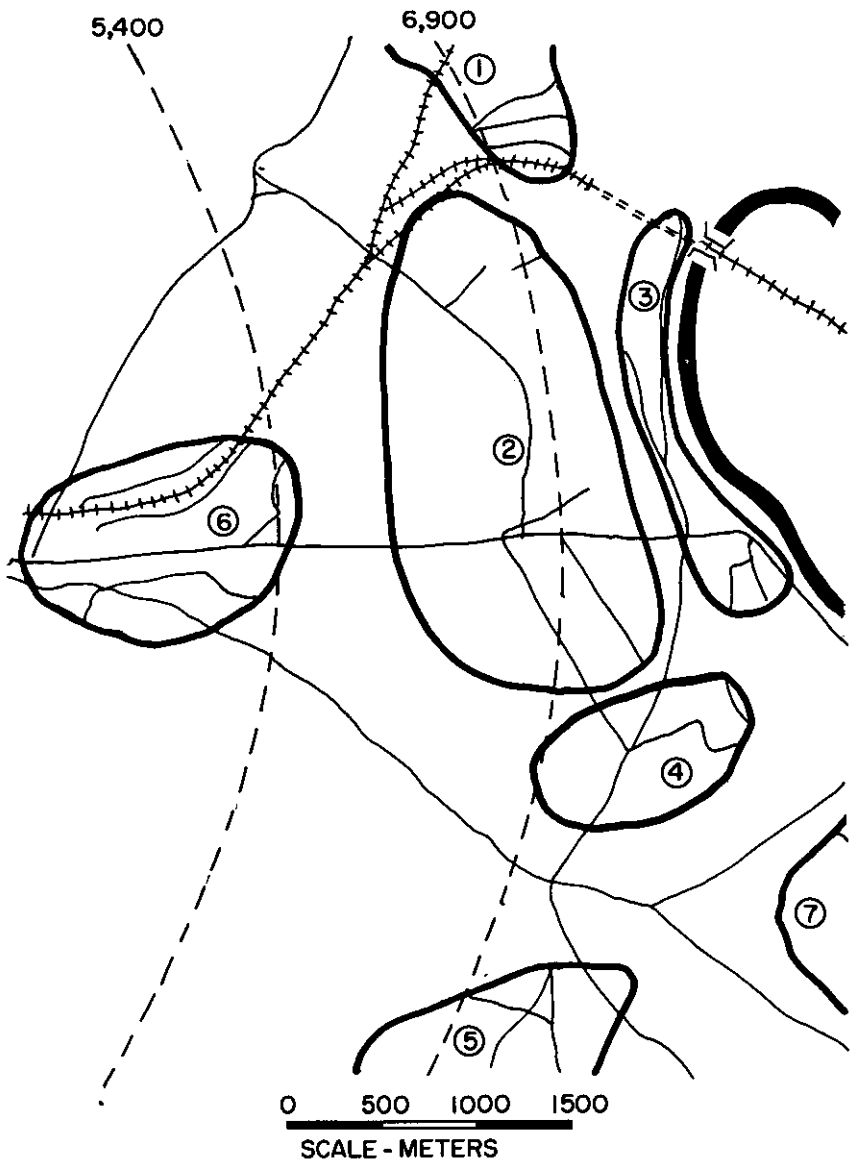

Figure 145. Detail of portion of subinstallation W.

split in three parts among W, X and Y. Each subinstallation area will be organized for local defense, and will maintain such random dispersion for protection against conventional or small nuclear weapons as is consistent with operating efficiency and security. An airstrip is placed as shown between X and W across the river from M. This is centrally located with respect to X and W, connected to them by good secondary roads. An alternate strip is placed as shown between X and Y. The replacement center disposes itself in three subinstallations, one each at X, Y, and W. It places its headquarters at X. The hospital area breaks into three parts also, with general hospitals near W, X, and Y, and the hospital center headquarters near W. Hospital subinstallations will be located far enough from the other subinstallations that conventional weapons attacks on them will not endanger the hospitals.

d. Organization Within a Subinstallation Area. Figure 145 gives a more specific look at a portion of subinstallation area W to assist in visualizing its composition. It would be necessary for actual terrain reconnaissance to precede the placement of the installations to verify the suitability of the locations.

- (1) Area 1 is assigned to QM class III activities. It is in a separate valley with access to roads and railroads, and woods and brush are generally distributed through the area to facilitate camouflage. It is sufficiently distant from M that, particularly with the favorable terrain for blast shielding, above ground storage of POL either in tanks, drums or 5-gallon cans would be safe from a design weapon aimed at M. It will, therefore, have a low priority on engineer effort for protection of supplies. Protection of personnel by rapidly constructed personnel shelters will still have a high priority for this installation because personnel will probably become casualties to the design weapon if in open or in woods at this distance from M, and because without shelters fallout from a surface burst would normally cause casualties.
- (2) Area 2 is assigned to a section of an ordnance ammunition company. Access to rail and road facilities, readily available camouflage and concealment in woods and brush, and a good existing internal secondary road net make this suitable to ammunition storage. Protective revetments or trenches will be needed for the ammunition to avoid damage from the design burst over most of the area, which is not naturally sheltered from blast. Tree blowdown from a blast may cause some damage to supplies and cause difficulty in recovery, but the camouflage gained will compensate.
- (3) Area 3 is a personnel living area which affords excellent shelter for housing military and civilian personnel for areas 1 and 2.

Rapidly constructed personnel shelters are used here in conjunction with locally available existing surface facilities.

- (4) Area 4 is the general depot headquarters area, on a good road net, containing existing buildings and wooded areas and some small valleys which facilitate personnel shelter. Rapidly constructed personnel shelters are used, initially including the protection of stock control records and central communications facilities. These last shelters are further improved as soon as possible.
- (5) Area 5 contains a replacement company and the replacement battalion headquarters with rapidly constructed personnel shelters.
- (6) Area 6 is the unloading area for the hospital and replacement unit for rail shipments. It is promptly cleared of incoming shipments and has no protective shelters in connection with it.
- (7) Area 7 contains the hospital. It is fairly safe from the design weapon except for fallout, since it is in a valley and some 8,500 meters from M. It requires rapidly constructed personnel shelters, however, for fallout protection and in case a nuclear weapon is dropped closer than M. It is sufficiently separated from the other subinstallation areas to be safe against conventional weapons or most small atomic weapon attacks on them.
- (8) Similar areas are laid out to the total extent of the area W, including the remaining portions of the subinstallation such as engineer, medical, QM II and IV, etc. They are placed outside the governing effects circles so as to minimize overall engineer construction effort, particularly that of highest priority, and so as to facilitate camouflage, concealment and deception.

e. Effects of an Enemy Attack Upon the Installation.

- (1) Figure 146 shows the radii of 10 percent probability of effects, as tabulated in paragraph 1, of a 5 MT weapon dropped 1,000 meters due east of the center of M and one 1 MT weapon dropped on each airstrip; and figure 147 shows the same radii on a detailed portion of area W. Without the use of shelters and trenches, the weapons would have effectively destroyed the installation. With fortifications, the destruction is limited mostly to those activities in the central area and those supplies and equipment whose protection is not worth the effort required.
- (2) The effects in the various subareas of area W are as follows:
 - (a) In Area 1 there will be hardly any casualties among personnel in foxholes. Some above ground POL will be destroyed by direct blast effects, and some more by tree blow-down, but most supplies should be affected only slightly.

- (b) In Area 2, tree blowdown will be very disruptive along the north-south roads, but the ammunition supplies will not suffer noticeably. Personnel casualties will be light.
- (c) Area 3 and Area 7 will receive negligible damage.
- (d) Area 4 will be damaged by tree blowdown, but casualties should be slight if the personnel are adequately warned.
- (e) The replacement units in area 5 will have insignificant casualties as long as shelter has been provided for all the transients.
- (f) The rolling stock in area 6 will be seriously damaged and

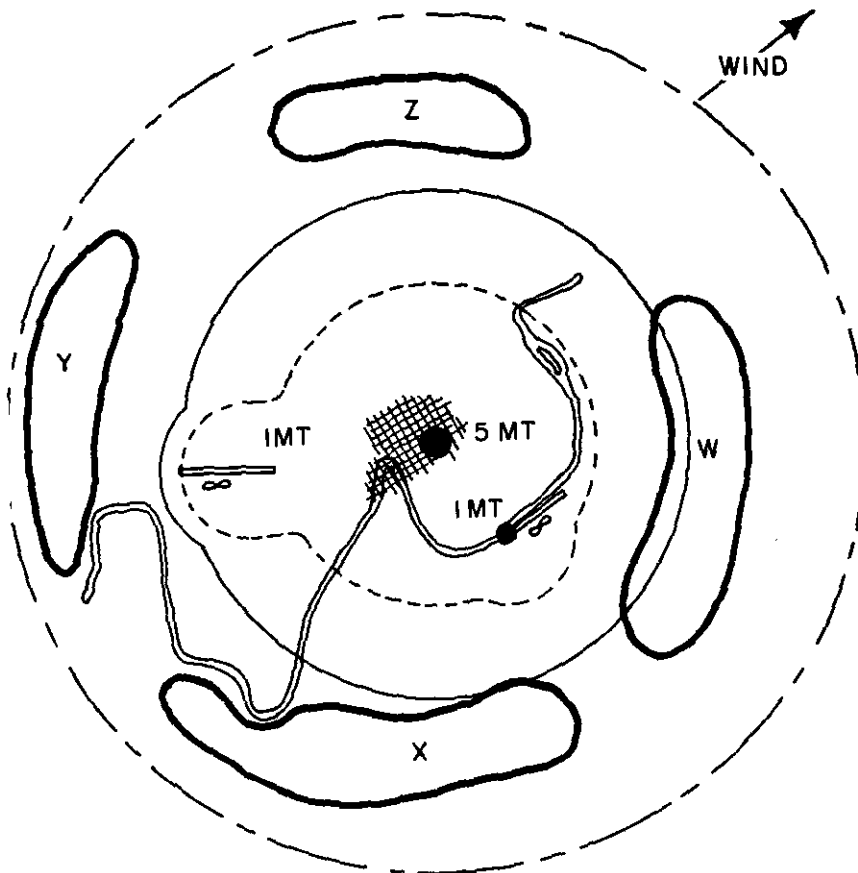

10% PROBABILITY OF
CASUALTIES OR SEVERE
DAMAGE TO:

SCALE: 1" = 3500 METERS

PERSONNEL IN OPEN: ————
PERSONNEL IN FOXHOLES: ————
PERSONNEL IN SHELTERS AND
SUPPLIES IN TRENCHES: - - - -

Figure 146. Initial effects of weapon bursts on an area dispersed installation.

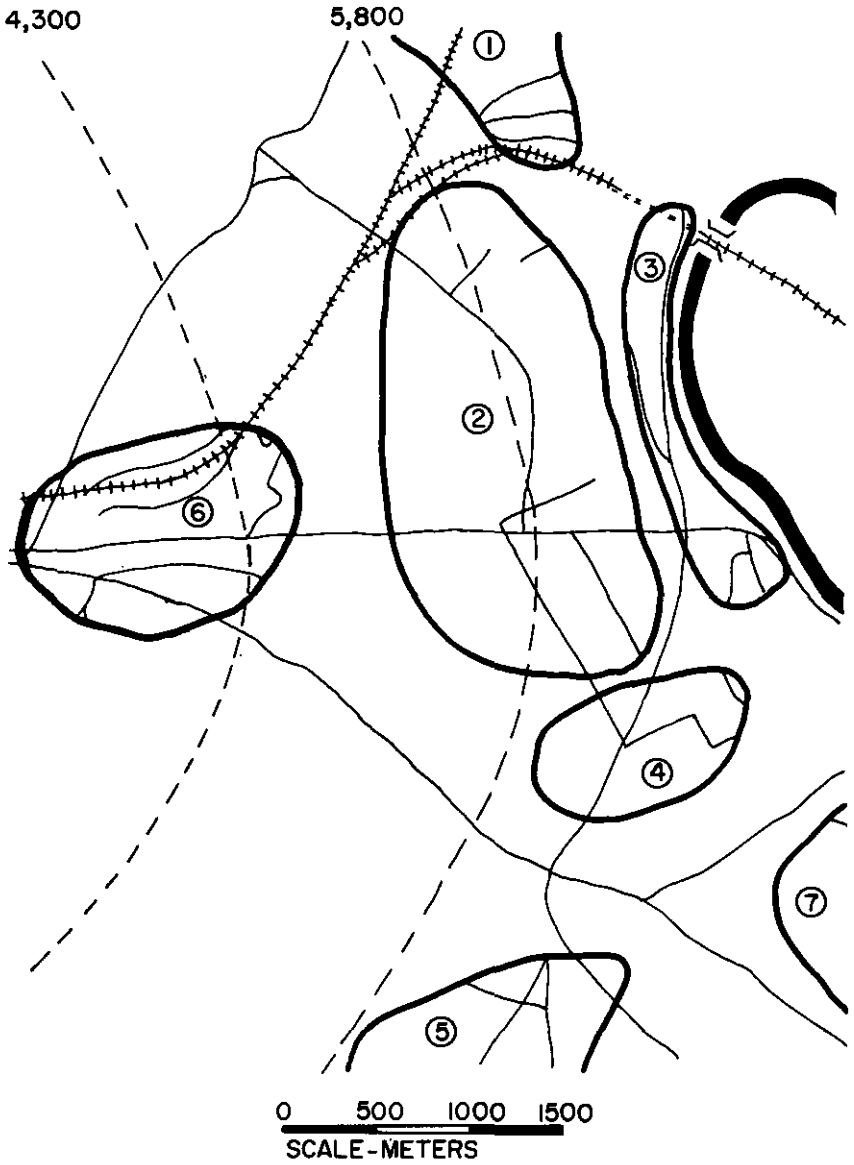

Figure 147. Initial effect of weapon bursts on portion of subinstallation in an area dispersed installation.

- most of the personnel will be casualties. The railroad tracks should receive negligible damage.
- (3) Figure 148 shows the approximate 48 hour dose received on the installation. Personnel in areas X and Y would be little affected if they improved upon their foxhole after the bursts and stayed in them for a few hours after fallout began descending. Areas Z and W receive significant doses of radiation in certain portions but their personnel would be well protected by shelters with at least two feet of earth cover. Operations would be stopped for a few days until they could be resumed on an emergency basis.

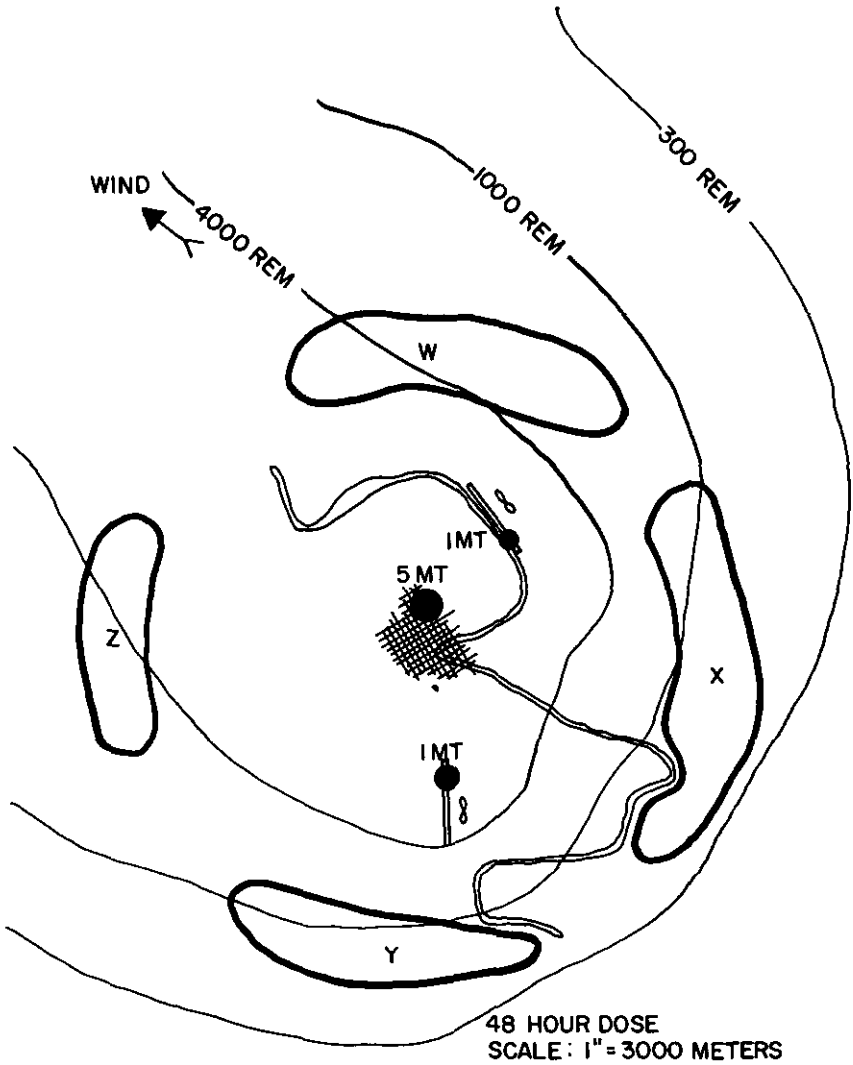

Figure 148. Residual radiation contours resulting from weapon bursts on an area dispersed installation.

APPENDIX IV

FIELD DESIGN PROCEDURES

1. General

When the standard structures presented in chapters 8 and 9 can not be used due to lack of the required materials or a requirement for a larger structure, the field design procedures presented in this appendix may be used to design a suitable structure.

2. Roof Design

a. *Laminated Roof.* Table XXII shows the thickness of laminated wood roof required to support various thicknesses of earth cover over various spans. The planks should extend from support to support in all layers, and adjoining edges should be staggered from one layer to the next.

Table XXII. Thickness in Inches of Laminated Wood Roof Required To Support Various Thicknesses of Earth Cover Over Various Spans

| Thickness of earth cover in feet | Span width in feet | | | | | |
|----------------------------------|--------------------|---|----|---|---|---|
| | 2½ | 3 | 3½ | 4 | 5 | 6 |
| 1½ | 1 | 1 | 2 | 2 | 2 | 2 |
| 2 | 1 | 2 | 2 | 2 | 2 | 3 |
| 2½ | 2 | 2 | 2 | 2 | 2 | 3 |
| 3 | 2 | 2 | 2 | 2 | 3 | 3 |
| 3½ | 2 | 2 | 2 | 2 | 3 | 3 |
| 4 | 2 | 2 | 2 | 2 | 3 | 4 |

b. *Stringer Roofs.* Table XXIII shows the spacing of stringers required to support a one inch thick wood roof with various thicknesses of earth cover over various spans. Stringers are 2 inches by 4 inches unless otherwise indicated.

c. *The roof designs shown here are not designed to be shellproof, even under an earth and rock cover. The roofs shown with the cover indicated are fragment proof and will give substantial radiation protection, if properly designed entrances are provided. These roofs may under certain conditions be shellproof.*

Table XXIII. Center-to-Center Spacing (in inches) of Wooden Stringers Required to Support a One-Inch Wood Roof Over Various Spans

| Thickness of earth cover in feet | Span width in feet | | | | | | | | | | |
|----------------------------------|--------------------|-------|-------|-------|-------|-------|-------|-------|-------|-------|---|
| | 2½ | | 3 | | 3½ | | 4 | | 5 | | 6 |
| | 2 × 4 | 2 × 4 | 2 × 4 | 2 × 6 | 2 × 4 | 2 × 6 | 2 × 4 | 2 × 6 | 2 × 6 | 2 × 6 | |
| 1½ | 40 | 30 | 22 | ----- | 16 | ----- | 10 | ----- | 18 | | |
| 2 | 33 | 22 | 16 | ----- | 12 | ----- | 8 | 20 | 14 | | |
| 2½ | 27 | 18 | 12 | ----- | 10 | ----- | ----- | 16 | 10 | | |
| 3 | 22 | 14 | 10 | ----- | 8 | 20 | ----- | 14 | 8 | | |
| 3½ | 18 | 12 | 8 | 24 | ----- | 18 | ----- | 12 | 8 | | |
| 4 | 16 | 10 | 8 | 20 | ----- | 16 | ----- | 10 | 7 | | |

3. Cap Design

a. *General.* The graph shown as figure 149 is used to determine the required size of rectangular caps. This graph is based on the following assumptions:

- (1) The timber used for caps has a maximum allowable bending stress of 2,400 psi, and a maximum allowable shear stress of 150 psi.
- (2) The overhead cover on the shelter has a density of 150 lbs/ft³.
- (3) The caps have end supports only (one span, two supports).

Before using the graph, it is necessary to compute the bending and shear formulas.

b. *Formulas.*

Bending = (cap span)² × stringer span × cover thickness.

Shear = Cap span × stringer span × cover thickness.

c. *Example.* Consider a cap span of 8 feet with end supports, carrying stringers with a span of 6 feet. The roof cover thickness is 3 feet.

Bending = (8)² × 6 × 3 = 1152

Shear = 8 × 6 × 3 = 144

For shear, enter the graph at the top at a value of 144. Move downward, contacting the sloping shear lines to determine cap depth. Move horizontally to the left from the point of contact with the shear line to determine the stringer width. For bending, enter the graph at the bottom at a value of 1152, and employ a procedure similar to that used for shear, this time using the bending lines. It is seen that several sizes of timber may be used. The choice between them is an economic one.

| Shear | | Bending | |
|-------|----|---------|----|
| D. | W. | D. | W. |
| 6 | 10 | 6 | 10 |
| 8 | 8 | 8 | 5 |
| 10 | 6 | 10 | 4 |
| 12 | 5 | 12 | 3 |
| 16 | 4 | 16 | 2 |

For a given timber depth, the larger width (shear or bending) must be chosen.

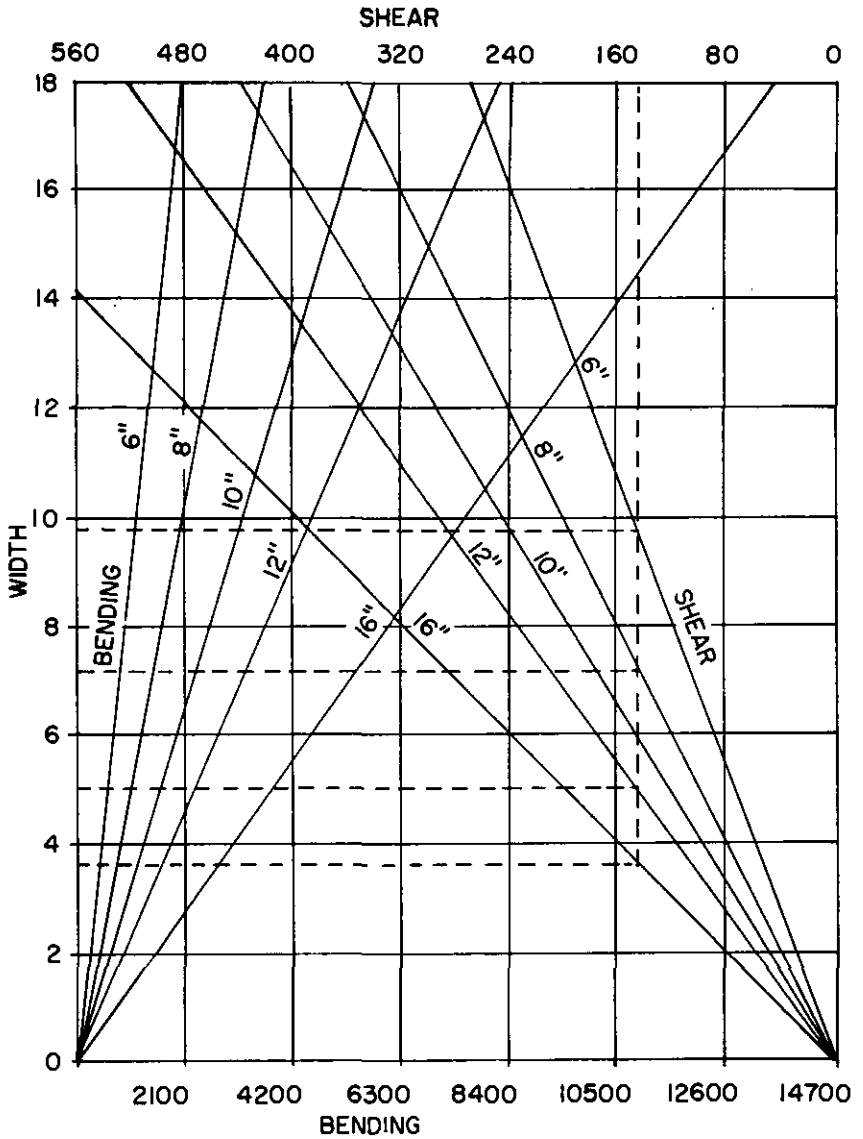

Figure 149. Rectangular cap design.

4. Post Design

Posts should be the same size as the cap. For dimensioned lumber the post should be square and the same dimension as the width of the cap.

5. Footing Design

a. *General.* The total weight of the structure and its overhead cover must be transmitted to the earth on which the structure rests in such a way that the allowable bearing value of the soil is not exceeded. For various soils, the allowable bearing pressures are given in paragraph 131d, FM 5-34.

b. *Continuous Wood Sill.* A sill of the same size as the cap, embedded in the earth floor, is desirable if its bearing area divided by the total weight of the structure is a figure less than the soil bearing capacity of the soil. When this is not possible using a sill the same size as the cap, the bearing area of the sill on the ground must be increased to remain within the bearing capacity of the soil.

c. *Plank or Grillage Footings.* When the width of footing required is greater than the width of normally available timber, planks may be laid transversely under a smaller sill to spread the load to the required area of earth. When planks are used the plank thickness in inches must not be less than the plank length in feet.

d. *Natural Timber Caps.* The depth of natural timber caps is the same as that for rectangular caps. To determine the width, multiply the depth by 1.2.

6. Bracing Design

a. Natural timber bracing should be $\frac{1}{2}$ the diameter of the post but not less than 3 inches in diameter.

b. Dimension timber bracing should have at least $\frac{1}{2}$ the cross sectional area of the post, but not less than 2 inches thick on the smallest side.

INDEX

| | Paragraphs | Pages |
|--|--------------------------|---------------|
| Abatis..... | 139 | 214 |
| Administrative support installation..... | 27-31 | 27 |
| Aircraft—delivered weapons..... | 10 | 9 |
| Air locks..... | 89 | 142 |
| Ammunition shelters..... | 77a | 132 |
| Antigrenade netting..... | 81 | 137 |
| Antivehicular obstacles..... | 110-11, 115c, 135-146 | 165, 169, 205 |
| Apertures. (See also Entrances.)..... | 79-80, 82 | 135, 137 |
| Artillery weapons | | |
| Protection..... | 9b | 8 |
| Protection..... | 72-78 | 127 |
| Barbed wire entanglements..... | 107-109 | 160 |
| Beach obstacles, used..... | 153 | 234 |
| Construction..... | 124-132 | 177 |
| Estimates for material and labor..... | 133-134 | 203 |
| Materials..... | 119-123 | 171 |
| Bayonet, protection..... | 7b | 8 |
| Beach obstacles..... | 112-115, 149-154 | 166 236 |
| Barbed wire..... | 153 | 234 |
| Cribs..... | 150a | 227 |
| Expedient..... | 145-146, 154 | 219, 236 |
| Hedgehogs..... | 151b | 233 |
| Nutcrackers..... | 150g | 230 |
| Posts..... | 150d | 229 |
| Ramps..... | 150f | 230 |
| Scaffolding..... | 150c, 151a | 229, 233 |
| Tetrahedrons..... | 150b | 227 |
| Tripods..... | 150e | 230 |
| Biological agents..... | 12 | 9 |
| Protection..... | 13-14 | 10 |
| Blast effects, protection..... | 15-16, 22b, 85 | 11, 20, 141 |
| Blast loading, definition..... | 5a | 4 |
| Bombs, protection..... | 10 | 9 |
| Bracing frames..... | 34d | 35 |
| Bridge demolition..... | 148c | 223 |
| Burster layer..... | 37 | 43 |
| Camouflage layer..... | 37 | 43 |
| Casualty gas, protection..... | 13b, 14 | 10 |
| Caves..... | 56e | 87 |
| Chemical agents, protection..... | 12-13 | 9 |
| Close combat weapons, protection..... | 7 | 7 |
| Collective protector. (See Gas-particulate filter unit.) | | |
| Combat equipment, protection..... | 21-22, 59, 70 | 20, 100, 125 |

| | Paragraphs | Pages |
|---|--|-----------------------------|
| Combat material, protection..... | 21-22, 32 <i>a</i> , 50, 71 | 20, 34, 100, 125 |
| Concealment, definition..... | 5 <i>b</i> | 5 |
| Concertina..... | | |
| Standard..... | 120, 129 | 173, 193 |
| Triple standard..... | 130 | 194 |
| Conventional weapons, protection..... | 6 <i>a</i> | 7 |
| Cover..... | 5 <i>c</i> , 36-40, 52 <i>j</i> , 60-63, 68, 78 | 5, 42, 78, 103, 125, 132 |
| Cover support..... | 40 | 44 |
| Crater..... | 50 <i>a</i> , 136 | 62, 206 |
| Crawl trench..... | 52 <i>b</i> | 71 |
| Cribs..... | 137 <i>b</i> , 150 <i>a</i> | 208, 227 |
| Crouch-and-run trench..... | 52 <i>c</i> | 71 |
| Cubes..... | 142 | 217 |
| Cushion layer..... | 39 | 44 |
| Cut-and-cover shelters..... | 56 <i>d</i> | 88 |
| Cylinders..... | 143 | 218 |
| Debris hazard, protection..... | 16 <i>d</i> | 12 |
| Deceit, definition..... | 5 <i>d</i> | 5 |
| Defilade, definition..... | 5 <i>e</i> | 5 |
| Demolition charges, protection..... | 7 <i>c</i> | 8 |
| Demolitions..... | 33 <i>c</i> , 148 <i>c</i> | 35, 224 |
| Design of structures..... | App IV | 261 |
| Diffraction loading, definition..... | 5 <i>f</i> | 5 |
| Direct fire, protection..... | 9 <i>a</i> | 8 |
| Dispersion, protection afforded..... | 24, 27-31 | 25, 27 |
| Ditches..... | 135 | 205 |
| Double apron fence..... | 125 | 185 |
| Drag loading..... | 16 | 11 |
| Definition..... | 5 <i>g</i> | 5 |
| Protection..... | 16 <i>c</i> | 11 |
| Drainage..... | 45-48 | 56 |
| Dustproofing layer..... | 38 | 43 |
| Electricity..... | 84 | 139 |
| Emplacements..... | 49-53 | 61 |
| Covered..... | 16 <i>d</i> | 12 |
| Definition..... | 5 <i>i</i> | 5 |
| Emergency..... | 50 | 61 |
| Progressive development..... | 53, 68, 78 | 83, 119, 132 |
| Prone..... | 50 <i>c</i> | 63 |
| Protection afforded from chemical and biological agents..... | 13 | 10 |
| Protection afforded from drag loading..... | 16 <i>c</i> | 11 |
| Protection afforded..... | | |
| Radiation..... | 17 | 14 |
| Revetted..... | 16 <i>d</i> | 12 |
| Unrevetted..... | 16 <i>d</i> | 12 |
| Emplacements, foxholes..... | | |
| Offset w/2-man shelter..... | 56 <i>b</i> | 88 |
| One-man..... | 51 <i>a</i> | 63 |
| Two-man..... | 51 <i>b</i> | 68 |

| | Paragraphs | Pages |
|---|-----------------------------------|--------------|
| Emplacements, trenches | | |
| Crawl..... | 52 <i>b</i> | 71 |
| Crouch-and-run..... | 52 <i>c</i> | 71 |
| Fighting..... | 52 <i>d</i> | 73 |
| Skirmisher's..... | 50 <i>b</i> | 62 |
| Standard..... | 52 <i>e</i> | 73 |
| Emplacements, weapons | | |
| Gun, 155-mm..... | 74 | 127 |
| 280-mm..... | 75 | 127 |
| Howitzer, 8-inch..... | 74 | 127 |
| 105-mm..... | 73 | 125 |
| 155-mm..... | 73 | 125 |
| Machine Gun, Caliber .30..... | 61 | 103 |
| Caliber .50..... | 62 | 108 |
| Mortar, 4.2-inch..... | 66 | 119 |
| 81-mm..... | 65 | 119 |
| Rifle, automatic..... | 60 | 100 |
| 106-mm..... | 64 | 118 |
| Rocket launcher, 3.5-inch..... | 63 | 116 |
| Self-propelled..... | 76 | 127 |
| Tank mounted..... | 76 | 127 |
| Enfilade fire, definition..... | 5 <i>h</i> | 5 |
| Entanglements. (See Barbed wire entanglements.) | | |
| Entrances. (See also Apertures.)..... | 16 <i>c</i> | 11 |
| Blackout precautions..... | 87 | 142 |
| Emergency..... | 88 | 142 |
| Safety devices..... | 85-86 | 141 |
| Equipment, combat, protection..... | 21-22, 59, 70 | 20, 100, 125 |
| Excavation..... | 33, 135 <i>b</i> | 34, 205 |
| Excavation tools..... | 33 <i>a</i> , 33 <i>b</i> | 34 |
| Exits, emergency..... | 88 | 142 |
| Explosives for excavating..... | 33 <i>c</i> | 35 |
| Fallout, protection..... | 17 <i>d</i> , 22 <i>b</i> , 28-31 | 16, 20, 29 |
| Fence | | |
| Double apron..... | 125 | 185 |
| Four strand cattle..... | 127 | 190 |
| Low wire..... | 126 | 189 |
| Standard concertina..... | 120, 129 | 173, 193 |
| Triple standard concertina..... | 130 | 194 |
| Field design procedures..... | App IV | 261 |
| Fighting trench..... | 52 <i>d</i> | 73 |
| Firing ports..... | 79-82 | 135 |
| Flamethrowers, protection..... | 13 <i>a</i> , 14 | 10 |
| Flooding as an obstacle..... | 148 <i>b</i> | 223 |
| Fortification protection factors..... | App II | 239 |
| Four strand cattle fence..... | 127 | 190 |
| Foxholes | | |
| Offset w/2-man shelter..... | 56 <i>b</i> | 88 |
| One-man..... | 51 <i>a</i> | 63 |
| Two-man..... | 51 <i>b</i> | 68 |
| Frames, bracing..... | 34 <i>d</i> | 38 |
| Framing, wood..... | 34 <i>b</i> | 35 |
| Fuels..... | 91 | 147 |

| | Paragraphs | Pages |
|--|-----------------------|---------------------|
| Gap..... | 5j, 103 | 5, 158 |
| Gas, protection..... | 13b, 14 | 10 |
| Gas, particulate filter unit..... | 13b, 14 | 10 |
| Grenades, protection..... | 7a, 81 | 7, 137 |
| Ground, organization..... | 26 | 26 |
| Hand grenades. (See Grenade.) | | |
| Hand tools, use..... | 33a | 34 |
| Heating..... | 90-93 | 147 |
| Hedgehogs..... | 140, 151b | 216, 233 |
| High wire entanglement..... | 128 | 192 |
| Horned scullies..... | 152 | 234 |
| Hurdles..... | 137a | 208 |
| Ice as an obstacle..... | 148d | 224 |
| Illumination..... | 83-84 | 137 |
| Incident radiation, definition..... | 5k | 5 |
| Indirect fire..... | 9b | 8 |
| Infantry heavy weapons, protection..... | 9a | 8 |
| Installations, administrative support, protection..... | 27-31 App III | 27, 246 |
| Knife rest..... | 131b | 198 |
| Lanes..... | 51, 103 | 63, 159 |
| Layer | | |
| Burster..... | 37 | 43 |
| Camouflage..... | 37 | 43 |
| Cushion..... | 39 | 44 |
| Dustproofing..... | 38 | 43 |
| Waterproofing..... | 38 | 43 |
| Light, precautions in using..... | 87 | 142 |
| Lighting..... | 84 | 139 |
| Liquid agents, protection..... | 13b, 14 | 10 |
| Liquid contaminants. (See Liquid agents.) | | |
| Low wire fence..... | 126 | 189 |
| Machine gun emplacements. (See Emplacements, weapons.) | | |
| Materiel, combat, protection..... | 21-22, 32a, 59, 71 | 20, 34, 100, 125 |
| Minefields..... | 105-106 | 159 |
| Mobility, protection afforded..... | 23 | 22 |
| Napalm, protection..... | 13a, 14 | 10 |
| Netting, protection from grenades..... | 81 | 137 |
| Nuclear radiation..... | 15, 17, 22b | 11, 14, 20 |
| Nuclear weapon effects..... | 15 | 11 |
| Nuclear weapon effects, comparison of protection requirements..... | 19 | 18 |
| Nutcrackers..... | 150g | 230 |
| Obstacles..... | 94-104 | 155 |
| Artificial. (See Specific names.) | | |
| Camouflage..... | 102 | 158 |

| | Paragraphs | Pages |
|--|-----------------------------------|----------------------------|
| Construction..... | 119-154 | 171 |
| Defensive..... | 97c, 109a | 156, 163 |
| Definition..... | 5m | 6 |
| Employment..... | 98-104 | 157 |
| Methods of improving..... | 148 | 223 |
| Natural..... | 97a, 116-118, 147-148 | 156, 170, 223 |
| Phony..... | 146 | 221 |
| Portable..... | 107, 131 | 160, 198 |
| Protective..... | 97c | 156 |
| Underwater..... | 149-154 | 227 |
| Ocean beach defenses..... | 113 | 166 |
| Organization of the ground..... | 26 | 26 |
| Overhead cover. (See Cover.) | | |
| Overpressure, protection..... | 16 | 11 |
| Parapets..... | 51a, 52, 61-62, 65-66, 73-75, 76b | 63, 71, 103, 119, 127, 129 |
| Physical protection, definition..... | 5n | 6 |
| Pole charge, protection..... | 7c | 8 |
| Posts..... | 138, 150d, 152 | 208, 220, 234 |
| Prefabricated construction..... | 35 | 40 |
| Progressive development of artillery weapons emplacements..... | 78 | 132 |
| Progressive development of protection..... | 53, 58 | 83, 98 |
| Pronc emplacements..... | 50c | 63 |
| Protection, comparison of requirements..... | 19, 20 | 18 |
| Radiation..... | 15, 17c, 18, 22 | 11, 14, 17, 20 |
| Radiation transmission factors..... | 55, 56 | 85 |
| Reaction time, definition..... | 5o | 6 |
| Revetment..... | 5p, 41-44 | 6, 46 |
| River line | | |
| Defenses..... | 114 | 166 |
| Obstacles..... | 112-114, 149-50 | 166, 227 |
| Satchel charge, protection..... | 7c | 8 |
| Screens..... | 146 | 221 |
| Shelters..... | 16d, 54-58 | 12, 85 |
| Accessories..... | 77c | 132 |
| Definition..... | 5g | 6 |
| Progressive development..... | 58 | 98 |
| Protection afforded from chemical and biological agents..... | 14 | 10 |
| Protection afforded from drag loading..... | 16c | 11 |
| Protection afforded from radiation..... | 17 | 14 |
| Skirmisher's trench..... | 50b | 62 |
| Small arms, protection..... | 8 | 8 |
| Snow as an obstacle..... | 148d | 224 |
| Soil, susceptibility to ground shock..... | 16d | 12 |
| Standard concertina..... | 120, 129 | 173, 193 |
| Standard trench..... | 52e | 73 |

| | Paragraphs | Pages |
|--|----------------|---------------|
| Stoves..... | 92 | 147 |
| Sumps..... | 51a | 63 |
| Tetrahedrons..... | 141, 144, 150b | 217, 218, 227 |
| Thermal Radiation..... | 18, 22b | 17, 20 |
| Tracked vehicles, protection..... | 11 | 9 |
| Translation, definition..... | 5r | 6 |
| Trench | | |
| Crawl..... | 52b | 71 |
| Crouch-and-run..... | 52c | 71 |
| Fighting..... | 52d | 73 |
| Skirmisher's..... | 50b | 62 |
| Standard..... | 52e | 73 |
| Triple standard concertina..... | 130 | 194 |
| Tripods..... | 150e | 230 |
| Underwater obstacles..... | 149-154 | 227 |
| Units, protection..... | 23, App II | 22, 239 |
| Wall construction..... | 34c | 37 |
| Waterproofing layer..... | 38 | 43 |
| Weapons, comparison of protective requirements..... | 19, 20 | 18 |
| Weapons, aircraft delivered, protection..... | 10 | 9 |
| Weapons, artillery | | |
| Protection from..... | 9 | 8 |
| Protection of..... | 72-76 | 127 |
| Weapons, biological agents..... | 12, 13 | 9, 10 |
| Weapons, chemical agents..... | 12, 13 | 9, 10 |
| Weapons, close combat, protection..... | 7 | 7 |
| Weapons, conventional, protection..... | 6a | 7 |
| Weapons, crew served, protection..... | 21-22, 59 | 20, 100 |
| Weapons, heavy, protection from..... | 9a | 8 |
| Wire entanglements. (See Barbed wire entanglements.) | | |
| Wire fence. (See Fence.) | | |

By Order of *Wilber M. Brucker*, Secretary of the Army:

L. L. LEMNITZER,
General, United States Army,
Chief of Staff.

Official:

R. V. LEE,
Major General, United States Army,
The Adjutant General.

Distribution:

Active Army:

| | |
|--|---|
| DCSLOG (5) | Svc Colleges (5) |
| CNGB (2) | Br Svc Sch (300) except USAES (1000) |
| Tech Stf, DA (2) | PMST Sr Div (5) |
| Engr RD Lab (2) | GENDEP (2) |
| USCONARC (10) | Engr Sec, GENDEP (2) |
| USA Arty Bd (2) | Engr Dep (2) |
| USA Armor Bd (2) | Trans Terminal Comd (2) |
| USA Inf Bd (2) | Army Terminals (2) |
| USA AD Bd (2) | Ports of Emb (OS) (2) |
| USA Abn & Elct Bd (2) | Div Engr (2) |
| USA Avn Bd (2) | Dist Engr (2) |
| US ARADCOM (5) | Engr Fld Maint Shops (2) |
| US ARADCOM Rgn (5) | AMS (2) |
| OS Maj Comd (25) except USASETAF (10) | Engr Maint Cen (2) |
| MDW (10) | Engr Cen (10) |
| Armies (10) except First US Army (12) | Fld Comd, Def Atomic Spt Agey (2) |
| Corps (10) | Cm1C Engr Agey (2) |
| Div (25) | Yuma Test Sta (2) |
| Engr Bde (10) | Mil Dist (5) |
| Engr Gp (10) | USA Corps (Res) (5) |
| Engr Bn (5) | Sector Comd, USA Corps (Res) (5) |
| Eng Co (3) | MAAG (1) |
| USMA (25) | Units org under fol TOE: 5-500 (AD)(2) |

NG: State AG (3); units—same as Active Army except allowance is one copy to each unit.

USAR: Same as Active Army except allowance is one copy to each unit.

For explanation of abbreviations used, see AR 320-50.