



M 641
394
U.S. : Bureau of
Fisheries.
The food value of sea
mussels.

M 641
394
U.S. : Bureau of Fisheries
The food value of sea
mussels.

LEEDS UNIVERSITY LIBRARY
Special Collections

Cookery Camden

A-FIE



30106023295099

550 362448



IME

T.
de,
stan.
a f
e

L
U



Digitized by the Internet Archive
in 2015

<https://archive.org/details/b21537616>

THE FOOD VALUE OF SEA MUSSELS

From BULLETIN OF THE BUREAU OF FISHERIES, Volume XXIX, 1909

Document No. 742 : : : : : Issued February 24, 1911



WASHINGTON : : : : GOVERNMENT PRINTING OFFICE : : : : : 1911

✓

6c.

C. Lewis.
79147 ✓

641
394

639
4

T36244C

WITHDRAWN
FROM CAMDEN PUBLIC LIBRARY

THE FOOD VALUE OF SEA MUSSELS



By Irving A. Field

U. S. Fisheries Laboratory, Woods Hole, Mass.

CONTENTS.



	Page.
Introduction	87
Natural history of the sea mussel	87
Form and structure	87
Reproduction	89
Growth	92
Food	92
Enemies and parasites	95
Distribution and habitat	97
Present uses of sea mussels	97
Sea mussels as food	99
Palatability	100
Digestibility	100
Experiments to show available protein	101
Metabolism experiments	102
Composition and nutritive value	105
Mussels a cheap food	110
Preservation methods	111
Canning	111
Pickling	113
Drying	114
Cold storage	116
Recipes for cooking	116
Cultivation of mussels	119
Poisonous mussels	123
Summary, conclusions, and recommendations	125
Literature	126

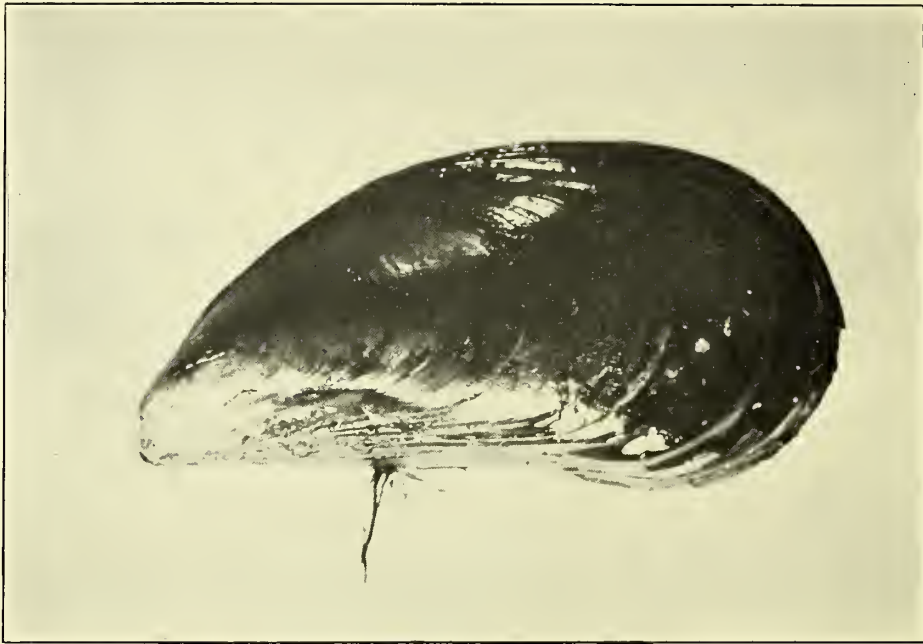

1.—The sea-mussel (*Mytilus edulis* Linneus).



2.—A bed of sea-mussels 1 year old.

THE FOOD VALUE OF SEA MUSSELS.

By IRVING A. FIELD.
U. S. Fisheries Laboratory, Woods Hole, Mass.

INTRODUCTION.

The purpose of this report is to make known the character and food value of one of our abundant, nutritious, and palatable sea products which has been little utilized up to the present time. The substance of a previous paper on the subject ^a is here added to and amplified into a more complete, and, it is hoped, more useful discussion.

The sea mussel has been, so far as most of this country is concerned, in the category of many other unappreciated resources which have later become valuable. Familiar examples are the sturgeon and the eel. Finnan haddie, too, have only recently come into popular favor. The large snail, or abalone, of the California coast, at first eaten only by the Chinese, is now relished by the American palate. Raising frogs for market is now a profitable industry in various parts of the United States, although in 1903 a bill introduced into the Pennsylvania legislature for the protection of frogs was greeted with shouts of laughter. The mussel bids fair to become as valuable as any of these products, for its merits are unquestionable, once the groundless prejudice shall have given way.

The basis of this report is a series of investigations carried on during three summers for the United States Bureau of Fisheries at its laboratory at Woods Hole, Mass.

NATURAL HISTORY OF THE SEA MUSSEL.

FORM AND STRUCTURE.

The common sea mussel, *Mytilus edulis* (pl. XVIII, fig. 1), along with the oyster and clam, is a member of the class Lamellibranchia in the phylum Mollusca. In form it is triangular ovate. The umbo or beak is much pointed and is situated at the anterior end of the valves (pl. XIX, fig. 3). In size it measures from 2 to 4 inches in length and from 1 to 1½ inches in diameter. Occasionally specimens 4½ inches long are found. The color of the shell proper varies from violet to pale blue. Externally it is covered with a horny epidermis of shining blue-black. The sea mussel is most apt to be confused

^a Field, I. A.: Sea mussels and dogfish as food. Proceedings Fourth International Fishery Congress, Bulletin U. S. Bureau of Fisheries, vol. XXVIII, 1908, p. 241-257.

with the horse mussel, *Modiola modiola*, which it most closely resembles. Close observation, however, will show that the umbo or beak of the horse mussel is not at the extreme end of the shell, but a short distance back near one margin, and that the epidermis is brown instead of blue.

Internally, the most conspicuous part of the body is the mantle (pl. XIX, fig. 3 and 4), which is made up of two lobes, each attached to and filling one of the two valves of the shell. Just before breeding, the mantles are thick and fleshy and assume a characteristic color by means of which it is possible, in a general way, to distinguish the two sexes. The males are white or pink, while the females vary from an orange to a brick red color. Another means of distinguishing the sexes is to note the surface character of the mantles, which in males shows closely aggregated follicles filled with spermatozoa (pl. XIX, fig. 1); in the females it presents a uniform granular appearance containing scattered groups of pigment cells (pl. XIX, fig. 2). During the quiescent period the mantles are thin and almost transparent.

The foot (pl. XIX, fig. 3), so well marked in the fresh-water mussel, is a muscular organ of small size in the sea mussel, tongue-like in form, with a longitudinal groove on the underside. Its hinder portion contains the byssus gland, which secretes the byssus or "beard" for the attachment of the mollusk (pl. XIX, fig. 3).

There are three important sets of muscles in addition to those in the foot. (1) The adductors (pl. XIX, fig. 3) are two in number. They extend across from one valve to the other and serve for closing the shell. The posterior adductor is the large muscle which it is necessary to cut before the shell is opened. The anterior adductor is inconspicuous and located, as its name implies, at the front end of the shell. (2) The retractors (pl. XIX, fig. 3), which are two in number and serve for withdrawing the foot, are long, narrow, paired muscles attached to the foot, from which one pair extends forward and the other backward to attach to the shell. (3) The pallial muscles (pl. XIX, fig. 3) are a row of delicate structures along the border of the mantle which serve to attach it to the shell.

The digestive tract has a complicated arrangement. It consists of a large mouth (pl. XIX, fig. 3) located at the anterior end just in front of the foot, a short gullet opening into a stomach which is surrounded by a large, dark-colored digestive gland, sometimes called the liver (pl. XIX, fig. 4). From the posterior end of the stomach the intestine passes backward to the posterior adductor muscle, where it turns forward in an oblique manner to the left side of the stomach. At this point it turns back again and passes through the ventricle of the heart and over the posterior adductor muscle to the anus, which is a short distance behind this muscle. The labial palps (pl. XIX, fig. 3), two pairs of loose flaps which lie just inside the edge of the mantle attached to the lower lip of the mouth, may be considered as accessory structures of the digestive system. They are covered with cilia and serve to direct food to the mouth.

The gills (pl. XIX, fig. 3) are a pair of filamentous structures extending along each side of the body from between the inner and outer palps to the posterior end of the animal. In cross section they present the form of a narrow W attached by the central part of the letter; the outer and inner arms remain free at their upper ends.

The kidneys, or so-called organ of Bojanus, consist of two symmetrical sacs on the ventral side of the body situated one on either side of the foot. Each extends backward to its opening, which is located on the inner side of the point of attachment of the gill just anterior to the posterior adductor muscle.

The circulatory system is well developed and completely closed as in all other mollusks. The heart lies in the mid-dorsal region in a pericardial chamber. From the heart a single large blood vessel is given off, which passes forward as the anterior aorta. It breaks up into a network of arteries that ramify all through the body. The blood is collected into a large, longitudinal vein on the ventral side of the body, from whence it passes through the kidneys to the gills and finally to the heart. The blood is colorless.

The nervous system, as in other lamellibranchs, is made up of three pairs of ganglionic centers connected one with the other and giving off nerves to supply the various surrounding organs. One pair is located in the head region with a ganglion on each side of the gullet, another in the foot, while the third, just ventral to the anterior edge of the posterior adductor muscle, supplies the digestive and reproductive organs, heart, gills, and posterior portion of the mantle.

The reproductive system is much more extensive than is found in most other mollusks. It is made up of a complicated branching network of canals which radiate throughout nearly the entire body. Internally each canal ends in a pocket or follicle. Externally the canals open out on either side of the body through a genital papilla which is at the inner point of attachment of the gills in front of the posterior adductor muscle and just in front of the kidney opening (pl. XIX, fig. 4). Since there is no definite organ which can be designated as an ovary or testis, it is impossible during the quiescent period to determine the sex of an individual. In mussels from Woods Hole, Mass., genital products were found developing in these canals during the early spring and summer months. (Compare fig. 1-4, pl. XXIII). According to Williamson (1907) the eggs arise from certain minute, brown-colored cells which he found present in the mantle of the female. My own observations are to the effect that the sexual products are formed by a process of budding from the cells lining the walls of the genital canals. At first the cells formed are extremely small and undergo rapid division. After a time division stops and the cells enter upon a period of growth. By the time the sperms and eggs are ripe they occupy almost the entire portion of the mantles, which are greatly distended by them. They fill the floor of the pericardial region, the wedge-shaped abdomen and cover to greater or less degree the outer walls of the digestive gland (pl. XIX, fig. 3).

REPRODUCTION.

With such an extensive genital system the mussel is capable of producing an enormous number of germ cells. For the past two summers between 200 and 300 mussels were kept in a shallow trough of running sea water where the process of egg laying and fertilization could be readily observed. The extrusion of the sexual elements on the part of two or three individuals began within an hour after bringing them in from the natural beds, and as time passed the number of spawning individuals

increased. After from twenty-four to thirty-six hours all the ripe mussels of a given lot were spawned out. It was observed that spawning started soonest among specimens which had been roughly handled before being placed in the trough. The duration of spawning varied with different individuals. Some would deposit practically all their products at one time, which required from twenty minutes to an hour. Others would spawn intermittently for short periods of several minutes each and finally stop altogether without having discharged half their genital products.

A male mussel discharges a stream of milt which will color the water for a distance of 10 or 12 feet before becoming too diffuse to be seen. In quiet water a female mussel will discharge her eggs so that they will fall in a heap. They can easily be removed by means of a pipette and measured in a graduate, a method which revealed the fact that mussels lay from 1 to 4 cubic centimeters of eggs at a single spawning. Knowing the average diameter of the eggs to be 0.07 mm., it is easy to calculate the number in a cubic centimeter, which approximates more than 3,000,000. On August 2, 1909, a mussel $3\frac{1}{4}$ inches long was seen to begin the deposition of eggs. A homeopathic vial of about 10 c. c. capacity was immediately placed in such a position as to receive the string of spawn as it was discharged. The egg laying proceeded at a remarkably rapid rate and continued for 15 minutes, when it suddenly stopped.

The mussel was watched for an hour longer and, when it was seen that no more eggs were to be laid, was removed from the trough and the shells opened to expose the mantle. The condition found is shown in figure 4 of plate XIX. All of the eggs except little patches here and there near the edge of the mantle had been discharged. Of course it was not known whether any of the eggs had been laid before this individual had come under my observation. The number of eggs laid measured 4 c. c., which means that this mussel liberated in round numbers about 12,000,000 eggs in 15 minutes. This is possibly more than the number usually produced. Three other mussels under my observation liberated from 6,000,000 to 9,000,000 each.

The period of reproduction varies for different regions and is influenced considerably by climatic conditions. It has been hard to determine when the mussel breeds on our northern Atlantic coast. Verrill and Smith (1873) and Goode (1887) say that the mussel breeds early in the spring. Ganong (1889), writing in Acadia, states that the height of the breeding season appears to be April and May. Mr. Charles H. Silverwood, of Pawtucket, R. I., who for years has been watching the habits of the mussels in Narragansett Bay, writes that the breeding season varies with the weather, beginning sometimes as early as the middle of June and lasting until late in August. Mr. George A. Carman, of Canarsie, N. Y., observes that the mussels in Long Island Sound spawn during April and May, while those in the open ocean do not spawn until about September 1. My own observations on the development of the sexual organs in mussels from Woods Hole, Mass., are in harmony with Silverwood's statement. Specimens of mussels were collected every month from February 7 until August 24. The mantles were sectioned and mounted for microscopical examination. The series of preparations show a gradual development of the sex cells during the whole period. No mature

sexual products were observed before July 3. On that date I found spermatozoa, which, when placed in sea water, were very active; they clustered about the eggs and by their active movements caused the eggs to slide gradually hither and thither across the microscopic field.

In England, on the Lancashire coast, Scott (1901) found that the mussels do not breed until midsummer. He kept the mussels in tanks under constant observation for a year and made frequent comparisons with those in natural beds. The sex organs developed at about the same rate in the two lots. The first eggs were discharged on May 6 by individuals in both the tanks and the beds. No spermatozoa, however, were observed until June 13 and the first developing eggs were found on June 14. The spawning season continued up to the middle of July. In France, where the water is much warmer than on our coast, the mussel spat appears in February and March. It is clear from the above evidence that the mussel breeds at various times between the months of February and September according to the temperature of the water in which it lives.

The ripe egg is a spherical body so small as to be hardly visible to the naked eye. It is surrounded by distinct membrane. On account of the great number of opaque yolk granules which fill the egg, none of its internal structures, such as the nucleus and nucleolus, are clearly visible under the microscope. The spermatozoa are pin shaped, with a conical protuberance upon the head. When liberated in the water they swim about actively and show great tenacity of life. Specimens placed in a bowl of sea water kept up active movements for more than six hours.

It has been an open question whether fertilization of the eggs takes place within the body of the female or not. M'Intosh (1885) and Wilson (1886) believe that it is accomplished outside of the female. That this is possibly so, Wilson has demonstrated by mixing ripe ova and spermatozoa in a beaker of sea water. He obtained the sexual products by mincing up portions of the mantle of the two sexes. Scott (1901), who studied the mussels kept in tanks, believes, on the other hand, that fertilization of the eggs takes place in the branchial chamber of the mother. He observed that "the embryos flow from the female in a slow, distinct stream." If the water is quiet, they settle on the bottom, forming a pinkish mass. In this position they continue to develop for from eight to twelve hours, finally becoming ciliated larvæ, which rise to the surface and swim about. At this time they are borne hither and thither by the tidal currents for about four days, so that eventually they reach almost every yard of our coast line within their range. At the end of this period the larvæ undergo important changes. They develop a shell and settle upon seaweeds, hydroids, or other convenient objects for attachment. At this stage they vary from $\frac{1}{7}$ to $\frac{1}{3}$ of an inch in diameter. The foot now becomes the chief organ of locomotion. By means of it they can creep from unfavorable situations over seaweeds and other objects to a more suitable position. In young forms the foot is capable of great extension and has the appearance of a long, white, flexible thread. By extending, attaching, and contracting this foot, the mussel readily draws itself forward. Of the myriads of brood mussels that appear shortly after the breeding season, only a small portion ever reach suitable places for growth, and of these only a few are destined to reach maturity.

GROWTH.

The rate of growth is dependent upon circumstances of situation, temperature, salinity of the water, and the amount of food available. Mussels in sheltered positions grow more rapidly than those exposed to the force of waves. The ideal location for the mussel is an estuary where food is supplied in great abundance, where the exposure to air between tides is not long, and where there is no deposition of silt. In such a place, if not too thickly crowded, they may grow to the average size of 2 or 3 inches in length in a single year. On the English coast, where they are cultivated by the bed system, it requires not less than two years and usually three years for them to reach a length of 2 inches. In France, where they are cultivated by the buchot method, that size is acquired in about a year and a half. On our Atlantic coast Charles H. Silverwood, of Pawtucket, R. I., says the mussels of Narragansett Bay reach marketable size, which I take to be not less than 2 inches, in from twenty-eight to thirty-four months.

Overcrowding is a very important factor affecting the growth of mussels. A single pair produces myriads of young, most of which are doomed to early death through lack of space and other conditions necessary to growth. After the free swimming stage is over, the young mussels often apply themselves in such close proximity to each other that no space is left for increase in size. In order to grow it is necessary for the stronger to smother out the weaker competitors. Sometimes the death rate from this cause is so high that the many disintegrating bodies apparently contaminate the closely applied living individuals and cause their destruction. This process may go on so far as practically to destroy what looks like a promising bed. Mussels on the margin of a thick cluster will almost always be found larger and in a more thrifty condition. Consequently, the healthiest individuals and specimens of largest size, other conditions being the same, are found in beds where the mussels do not lie in close contact with each other.

FOOD.

The food of the mussel is an important topic for study. A knowledge of the food and feeding habits of the marine animals which are utilized as food by man is of much greater importance than is ordinarily supposed. Especially is this true of forms like the mussel and oyster, which may be propagated by artificial means. The agriculturist who plants his grain regardless of the presence or absence of nitrates, phosphates, and sulphates in the soil is apt to reap very small crops. These chemical substances constitute an essential part of the food of plants, and the amount of the harvest's yield depends largely upon their presence in the ground on which it grows. The important relation of soil composition to crop production is well known and is receiving very serious investigation in every State of the Union.

The cultivation of marine products depends upon this same principle. The would-be oyster culturist who plants his seed oysters in any convenient spot, without knowledge of what constitutes their food or of its presence in the water, will be even less successful than

the farmer who ignores the first principles of agriculture. Up to the present time, however, very little study has been made of the food of marine animals or of the relative fertility of the waters in various parts of the sea. Such investigations as those of Peck (1894 and 1896) on the sources of marine food, and of Moore (1907) on the food of the oyster are of very great economic value.

My observations on the food of the mussel were necessarily limited. They were confined to the vicinity of Woods Hole and to the months of July and August. Lack of time did not permit a determination of the food value of the water over the mussel beds. During the summers of 1908 and 1909, however, a microscopic examination was made of the material found in the digestive tracts of 50 mussels.

Two methods were employed. The first was to extract the stomach contents by means of a pipette, which was thrust down the animal's gullet. The substance drawn out from the stomach was mixed with a few drops of water and a thin layer spread across the middle of a microscopic slide. The slide was then passed several times through the flame of an alcohol lamp, until the organisms were thoroughly fixed by the heat and the water almost evaporated to dryness. A drop of glycerin or of hot glycerin jelly was next applied and a cover glass pressed down upon it. Permanent mounts were later made from these preparations by cleaning the slides outside the boundary of the cover glass and ringing the mounts first with King's cement and, twenty-four hours later, ringing them again with asphaltum. This method proved best for preserving the animal forms, Protozoa, found in the stomach.

The second method was to place the mussels, immediately after removal from their natural beds, in small dishes of filtered sea water. After two or three hours' time the bottoms of the dishes were covered with intestinal discharges, which were removed by means of a pipette and transferred to a vial containing 95 per cent alcohol. After the sediment had completely settled the alcohol was drawn off and fresh alcohol added. The process was repeated, using absolute alcohol instead of the weaker grade. This was followed by a few minutes' treatment with xylol, and after removing most of the xylol three or four drops of a rather thin solution of Canada balsam were added. This mixture was allowed to stand for a few hours, until the xylol, sediment, and balsam were thoroughly mixed. Then, by means of a pipette, a large drop was transferred to a microscopic slide and on it was placed a cover glass. This method was found best for the preservation of the plant organisms which are known as diatoms. The diatoms, thus prepared, have had the pigments and coagulated protoplasm more or less completely removed, leaving a clear view of the striations and other markings on the skeleton.

The food of the mussel was found to consist of microscopic plants and animals which are carried by chance to the mollusk by water currents and are swept into the mouth by means of cilia on the gills and palps. The wall of the gullet is also lined with cilia, which direct the movement of the food material into the stomach. Not only food, but dirt and other indigestible substances are swept in. From the alimentary tracts of 50

mussels there were found 29 species of diatoms and 9 species of Protozoa.^a The relative abundance of each species is indicated in the following list:

ORGANISMS CONSTITUTING THE FOOD OF THE MUSSEL.

DIATOMACEÆ. [Plates xx and XXI.]

<i>Actinoptychus undulatus</i> Ehrenberg (fig. 12)	Common.
<i>Amphiprora lepidoptera</i> Cleve	Very common.
<i>Amphora proteus</i> Gregory (fig. 2)	Frequent.
<i>Biddulphia favus</i> (Ehrenberg) H. V. H. (fig. 11)	Do.
<i>Biddulphia rhombus</i> (Ehrenberg) W. Smith (fig. 1)	Do.
<i>Coscinodiscus excentricus</i> Ehrenberg (fig. 25)	Do.
<i>Grammatophora marina</i> Kützing (fig. 16)	Do.
<i>Hyalodiscus subtilis</i> Bailey (fig. 23)	Very common.
<i>Melosira sculpta</i> Kützing (fig. 14)	Do.
<i>Navicula didyma</i> Ehrenberg (fig. 6)	Common.
<i>Navicula lyra</i> Ehrenberg (fig. 8)	Occasional.
<i>Navicula lanceolata</i> Kützing (fig. 7)	Frequent.
<i>Navicula splendida</i> var. <i>puella</i> Ad. Schmitz (fig. 10)	Occasional.
<i>Nitzschia sigma</i> Grunow (fig. 15)	Common.
<i>Nitzschia sigma</i> var. <i>rigida</i> Grunow	Do.
<i>Nitzschia sigma</i> var. <i>sigmatella</i> Grunow (fig. 13)	Do.
<i>Pleurosigma affine</i> Grunow	Frequent.
<i>Pleurosigma angulatum</i> W. Smith (fig. 24)	Do.
<i>Pleurosigma balticum</i> W. Smith (fig. 18)	Common.
<i>Pleurosigma decorum</i> W. Smith (fig. 20)	Do.
<i>Pleurosigma elongatum</i> W. Smith (fig. 19)	Do.
<i>Pleurosigma naviculaceum</i> Brebisson	Very common.
<i>Rhabdonema adriaticum</i> Kützing (fig. 5)	Frequent.
<i>Rhabdonema arcuatum</i> Kützing (fig. 9)	Do.
<i>Rhizoselenia setigera</i> Brighter (fig. 17)	Very common
<i>Stephanopyxis appendiculata</i> Ehrenberg (fig. 21)	Occasional.
<i>Surirella ovalis</i> var. <i>ovata</i> Brebisson (fig. 4)	Common.
<i>Synedra gallionii</i> Ehrenberg (fig. 22)	Very common.
<i>Tabellaria fenestrata</i> Kützing (fig. 3)	Frequent.

PROTOZOA. [Plate XXII.]

<i>Ceratium fusus</i> Ehrenberg (fig. 3)	Frequent.
<i>Distephanus speculum</i> Stohr (fig. 4)	Common.
<i>Exuviælla lima</i> Ehrenberg (fig. 5)	Very common.
<i>Exuviælla marina</i> Cienkowsky (fig. 1)	Common.
<i>Glenodinium compressa</i> Calkins (fig. 2)	Do.
<i>Peridinium divergens</i> Ehrenberg (fig. 6)	Do.
<i>Prorocentrum micans</i> Ehrenberg (fig. 7)	Very common
<i>Tintinnopsis beroidea</i> Stein (fig. 9)	Do.
<i>Tintinnopsis davidoffi</i> Daday (fig. 8)	Common.

^aThe identifications were made by Mr. T. E. B. Pope, assistant of the Bureau of Fisheries.

The organisms included in this list are of the most primitive type, and, as Peek (1896) has demonstrated, are the ultimate source of food for all marine animals. The food of diatoms is the dissolved mineral matter removed from the soil and carried by rivers and the smaller streams down to the sea. It is absorbed through the surface of their bodies and transformed into living tissue. When their bodies have increased to a certain size, each individual divides into 2; as these grow they divide into 4, the 4 into 8, 8 into 16, etc., in geometric ratio. Under favorable conditions multiplication by this means is so rapid that millions may be produced in a day from a single individual. The Protozoa on which the mussel feeds multiply in much the same way, but in feeding habits differ from the diatoms in that they consume solid food, chiefly diatoms, in addition to absorbing soluble nourishment through the surface of the body. It is interesting to note, as Professor Brooks has pointed out, that these unicellular organisms are the means of bringing back to us in the form of food our mineral wealth which is continually being lost through the agency of erosion and solution.

ENEMIES AND PARASITES.

The enemies of the mussel are numerous. Killifish, cunners, and scup are very fond of the young mussels, greedily stripping them from the wharf piles, seaweeds, and other objects of attachment. The squeteague and tautog eat them from the beds. Among the mollusks the drill, *Urosalpinx cinereus*, destroys large numbers by boring a hole through the shell to the soft parts on which it feeds. On nearly every mussel bed numbers of shells may be found pierced with a hole about the size of a pin head which testify to the ravages of this voracious snail. Another snail, *Neverita duplicata*, is supposed to feed upon them in the same manner but the hole drilled is much larger. The so-called whelks, *Busycon canaliculata* and *B. carica*, also prey upon them to considerable extent. Perhaps the worst enemy is the starfish, which destroys them to as great a degree as it does the oyster. In England, Lebour (1907) reports that one whole bed of mussels at the mouth of the River Tyne was completely destroyed by this echinoderm. Crows and rats are said sometimes to eat mussels from the beds when they are exposed. Seaweeds like *Ulva* and eel grass (*Zostera marina*) are very injurious to the health and growth of mussels when they spread over the beds. Two of the largest beds near Woods Hole, Mass., have been practically ruined this year (1908) by a dense mass of eel grass which has sprung up over them. The weed by its growth not only gradually smothers the mussels, but causes the sand and mud to silt over them at such a rate that in a few months all signs of the bed are obliterated. The decaying bodies of the shellfish fertilize the soil and finally what was once a bed of mussels is a thrifty bed of eel grass.

The parasites of the mussel are few. The most common one is a little erab, *Pinnotheres maculatum*, which is very similar to the oyster erab but larger and with a tougher shell. It apparently works no injury to either the health or growth of the shellfish. Indeed, some observers believe the relation is symbiotic rather than parasitic. The

crab lives in the gill chamber, where it is protected from outside harm. In return for this protection it is said that the crab runs out and collects food which on returning it chews up in the gill chamber and shares with its host. From the examination of the stomach contents of several of these crabs, however, I found no evidence to support this belief. The only food material found consisted of diatoms and other microscopic organisms which probably would have been utilized by the mussel had not the parasite been present. Other hosts, such as the giant scallop and smooth scallop, are known to harbor this same species of crab. In describing it (Goode, 1884), Rathbun says:

Another species of *Pinnotheres* (*P. maculatum*) frequently occurs in the shells of the common sea mussel (*Mytilus edulis*) and the smooth scallop (*Pecten tenuicostatus*), between the gills of the animal. It attains a size larger than the oyster crab, and, as in the case of the latter, the females alone are parasitic, the males only having been found swimming at the surface of the sea. We have never heard of this species being eaten, probably because neither the mussel nor the smooth scallop has ever been used as food in this country. In the summer of 1880, while dredging off Newport, R. I., the United States Fish Commission steamer *Fish Hawk* came upon extensive beds of the smooth scallop, from a bushel of which nearly a pint of these crabs were obtained. Again, in 1881, the same species was encountered in great abundance by the same party in Vineyard Sound, in *Mytilus edulis*. As an experiment, they were cooked along with the mussels and found to be very palatable, although their shell is, perhaps, somewhat harder than that of *Pinnotheres ostreum*.

In my own experience with mussels I have observed no other parasite, but in Europe Lebour (1907) found a boring annelid, *Polydora ciliata*, which attacks the Northumberland mussels. The worm burrows through the shell from the outside, making a hole about the size of a pin. It causes the mussel to grow pearly excrescences, often to considerable extent, over the internal surface of the shell, which interfere with the muscular development of the animal and frequently almost destroys the posterior adductor muscle. If the pearly masses press upon the mantle, the reproductive lobes fail to develop in such places. Aside from injuring the mussel, the presence of the pearly excrescences gives the mussel an unsightly appearance and consequently renders it unfit for market.

Three larval trematodes are also found in the Northumberland mussels. The cercarias of the pearl trematode have been found in the mantle, the encysted cercarias of *Echinostomum secundum* in the foot, and a third unidentified species encysted in the liver. These trematodes, however, even when present in large numbers, work very little injury to their host.

Several species of mollusks are commonly found living with the sea mussel. Oysters are very often associated in the same beds with them and usually to the detriment of the oyster, if the mussels are present in large numbers. The mussels, having the power of free movement which the oysters do not possess, are able to acquire the more favorable positions for collecting food and thus deprive the oysters of much nourishment. The soft-shelled clam, *Mya arenaria*, and the hard-shelled clam, *Venus mercenaria*, are sometimes found growing among the mussels in good, healthy condition. Boat shells, *Crepidula fornicata* and *C. convexa*, are very common. Sometimes three or four individuals are attached to a single mussel, covering it almost completely, but apparently doing

no injury. Large numbers of periwinkles, *Littorina litorea*, are usually present on the beds, where, according to Allen and Todd (1902), by feeding upon the seaweed and thus keeping down the growing vegetation, they are a positive benefit to the mussel.

DISTRIBUTION AND HABITAT.

The sea mussel has a very wide distribution, occupying most of the coast line of the northern half of the Northern Hemisphere. It is circumpolar in range and extends down our eastern coast to North Carolina, down the Pacific coast to San Francisco, Cal., on the Asiatic coast to Japan, and on the European coast southward to the Mediterranean Sea. It is extremely abundant in the shallow, sheltered bays along the coasts of New Jersey, Long Island, Rhode Island, and Massachusetts.

The mussel seems to grow equally well in shallow and deep water. The bathymetrical range is from the littoral zone to about 100 fathoms. In the channel between Eastport, Me., and Deer Island, Verrill and Smith (1873) dredged them in from 40 to 50 fathoms and report that later their party dredged them in deeper water, but do not state from what depth. Some of the beds near Boston, Lynn, and Vineyard Sound lie in from 5 to 7 fathoms of water.

The favorite habitat of the mussel is where the water is slightly brackish, in shallow, protected bays and estuaries, on a bottom of mud rich in diatoms and covered more or less with stones or other solid objects to which it may attach by means of its byssal threads. The swift tideways of shallow inlets are also very good situations for the mussel. In these localities it is generally distributed from halfway between tide marks to a level several feet below low water. Other situations chosen by the animal are the piles and timbers of bridges, wharfs, and other objects, buoys, light-vessels, and rocks. But these locations are not so advantageous as the first ones mentioned, where mussels thrive in enormous beds, sometimes acres in extent, and where it is possible for a man to collect them daily by the ton.

PRESENT USES OF SEA MUSSELS.

The sea mussel, which is practically unknown as a food in the United States outside of New York City, has been utilized in other parts of the world for hundreds of years. According to Quatrefages (1854) the artificial culture of mussels for food began as early as the year 1035. Gould (1870) states that this shellfish is extensively used as a food in England, France, Norway, and Russia, and that it is more palatable than the common clam, *Mya arenaria*. Anderssen (1880) refers to it as a cheap and healthful food in America, France, Spain, and Portugal, where it is eaten raw with vinegar and pepper or boiled with milk. Goode (1884) writes that in Europe *Mytilus* holds an important place among the sea foods. Ganong (1889) says that as a food in Europe the mussel ranks second only to the oyster and takes the place of the soft-shelled clam, which is not eaten. This state of affairs we find at present reversed in America, where the soft-shelled clam is so popular that there is danger of the demand exceeding the supply, while the mussel, although exceedingly abundant, remains almost unutilized.

In the early colonial days, however, the settlers did eat mussels, as may be seen in Lescarbot's description of De Mont's settlement at St. Croix Island (Dochet Island of to-day), written in 1604. From this account Ganong (1889) makes the following quotation:

There is a little chapel built after the fashion of the savages, at the foot of which there is such a store of mussels as is wonderful, which may be gathered at low tide, but they are small. I believe that Monsieur De Mont's people did not forget to choose and take the biggest and left there but the small ones to grow and increase.

Of how the change in attitude toward the mussel and clam came about Ganong (1889) offers a very plausible explanation. He attributes it to the influence of the Indians, who ate the soft-shelled clam to the almost total neglect of the mussel, which, without reason, they superstitiously avoided. He furthermore thinks that this was unfortunate for us, since the mussel is a superior article of food. Goode (1887) refers to the use of mussels on the northwest coast of America, where it is the chief molluscan food. The Indian women and children collect them from the rocks every day the year around. Mussels are also consumed by the white inhabitants of that region. The Russian name for them is "black shells" (chornie rakooshka). In Alaska the method of cooking is by boiling; on Vancouver Island they are more commonly roasted.

Aside from being useful as an article of food, the sea mussel is valuable for other purposes, the most important of which is bait. In England the mussel is valued as the best hook bait known. The quantity used in Great Britain for this purpose amounts to more than 100,000 tons annually. In this country, however, fishermen rank it second to the squid in bait value.

Next in importance the mussels are valuable for the production of fertilizer. The so-called mussel mud constitutes one of the best fertilizers known. It is formed in places where the mussel beds are exposed to constantly depositing silt, which slowly destroys the mollusks and buries them beneath their offspring. The slow accumulation and decay forms a mass of very rich fertilizer, enormous quantities of which are taken along the coasts of Long Island and New Jersey, where it is considered excellent for carrots and onions. Goode (1887) stated that for the last thirty years he had seen it applied to lands where onions had been grown with a product varying from 300 to 600 bushels per acre. At that time the mussel mud sold, delivered several miles from where it was dug, at \$4 to \$5 a cord. It is gathered during the winter, piled up and exposed to the frosts, and then distributed in amounts of from 4 to 8 cords to the acre. For bait and fertilizer the value of the mussel fishery to the United States is estimated at \$37,500 annually.

Pearls of some value are sometimes found in mussels. Usually, however, although quite commonly present, they are small and of such poor color that the price they bring is low. In England they have been sold for from 1s. 6d. to 4s. per ounce.

The shells can be used by oyster planters for cultch upon which to catch oyster spat. When polished, they may be used in numerous ways. Artists use them as receptacles for gold or silver paint. They may be mounted on marble for paper weights

or made into pretty needle books and scent bottleholders, earrings, crosses, pins, and pin cushions. It is said that the American Indians and the natives of New Zealand used the mussel shells as tweezers for pulling out their beards.

SEA MUSSELS AS FOOD.

The fact that the sea mussel is so widely used as a food and yet is not utilized to any extent in the United States, where it grows prolifically in great beds, has led me to investigate its properties as a human food and to determine whether or not there is any reason for not making wide use of it in our diet. A food substance to be of value must measure up well to four standards. It must be palatable, digestible, nutritious, and economical.

By palatable I mean that the substance must have a flavor that will appeal to the average man's taste. To determine this quality, I found it necessary first to taste or eat the substance in question myself. If the flavor was agreeable and no evil results followed its use, I persuaded members of the Woods Hole scientific staff to follow my example and express their opinions concerning the dish. If they gave a favorable report, I had mussels served on certain tables of the Marine Biological Laboratory mess hall and to other persons who were interested enough to try them. The general opinion expressed was taken as an indication of the palatability of the food. By this method it was often possible, also, to obtain criticisms which would suggest new ways of preparing the substance to improve its flavor.

The second standard, digestibility, means several things. It relates to the proportion of the food that can be digested, to the ease or rapidity with which it can be digested, and to the degree in which the material agrees or disagrees with the user. Comparatively little is known concerning the relative rapidity of digestion of different foods within the body. Most of the current statements referring to this are apparently based on experiments carried on outside of the body, and it is certain that the processes in the two cases are not exactly the same. The artificial process takes much longer than the natural one, although the relative rates of digestion as regards different substances appear to be much the same. For example, under natural conditions, soft boiled eggs will digest more quickly than hard boiled ones. The same proportionate results are obtained by the artificial method. The artificial process serves merely to determine the rate of digestion of the substance compared with that of staple foods. How it agrees or disagrees with the user can only be determined by taking the article into one's own stomach and awaiting results.

The third standard, nutritive value, involves such questions as the ratio of edible portion to refuse, and the chemical composition and proportion of nutriment that can be absorbed by the body under normal conditions.

The fourth standard, economy, means that a food of high nutritive value must be so abundant and easily obtained that it can be sold reasonably cheap. If it can be readily prepared in various ways so that it may be preserved for long periods, its value is still further increased. Any food that measures up well to these four standards ought to find a large and ready market.

PALATABILITY.

From the standpoint of palatability I have abundant testimony from scores of persons who have eaten mussels prepared in various ways (pickled, steamed, roasted, stewed, and fried) that in flavor and texture they are superior to the long clam and fully equal to the oyster. A few people were inclined to rank them not so high. On July 30, 1907, pickled mussels were served on three tables of the Marine Biological Laboratory mess hall. About 36 persons ate of them and all expressed their appreciation of the unfamiliar dish. The only adverse criticism that was made related to the tough, muscular part of the foot, which was difficult to masticate.

Two days later one of the residents of Woods Hole was given four dozen mussels, which he took home for family use. He had them steamed and served with salt, pepper, butter, and oil. They were pronounced "elegant and superior to clams."

On August 3, 1907, mussels dipped in egg and cracker crumbs were fried and served to about 25 persons at the Marine Biological Laboratory mess hall. They were declared to be equal to or better than fried oysters, and were so relished, in fact, that there was a general call for more. A few days later, in answer to this request, a large quantity was prepared and served to 40 persons. Enthusiastic comments were made as to the appetizing appearance, rich flavor, and delicate texture of the flesh.

On August 13 mussel chowder was served to the same 40 persons and called forth the same favorable comments, especially as to richness of flavor and tenderness of the meat. The tender quality of the flesh is a point decidedly in favor of the mussel when compared with the clam, the meat of which latter in chowder is so tough that few persons ever think of trying to masticate it.

Mussel fritters were next tried on the tables of the mess hall on August 27. They were eaten with relish and pronounced excellent.

The following year, 1908, the work of preparing mussels in various ways and serving them in the mess hall to friends and visitors of the Bureau's laboratory was continued, with the result that quite a general interest in the food value of this shellfish has been aroused and a local demand now exists. For some years past at certain points along the coast of Rhode Island, New York, and New Jersey a few people have been in the habit of collecting mussels for their own personal use. Some of the summer visitors also have learned to eat them. I have met several persons living in the vicinity of New York City who say they have always prized the sea mussel as a food and that it is their custom to pickle a number every summer for use during the winter.

For the benefit of those interested in making use of the mussel in their diet, a few recipes for cooking them will be given in another section of this paper. They have been tried repeatedly and have proved to make most palatable dishes.

DIGESTIBILITY.

Personal testimony in various instances is very favorable to mussels for their digestibility. Persons with weak stomachs say that they can eat them without suffering any inconvenience. Others have eaten them just before retiring and experienced no

discomfort. One man with whom meat does not ordinarily agree states that he can eat freely of mussels and digest them without difficulty. Many persons have declared that in their opinion mussels are more digestible than either clams or oysters, a fact due to the character and properties of the flesh which by cooking is rendered tender and mealy, whereas the oyster and clam become very tough.

But the problem of really determining the digestibility of a given food material is surrounded with great difficulties. It is an easy matter for one to eat the food and learn by experience how it agrees or disagrees with him; but to determine the rate of digestion and the proportion of nutriment which the body absorbs from a given quantity of the food involves a series of very complex chemical studies.

EXPERIMENTS TO SHOW AVAILABLE PROTEIN.

By artificial methods it is possible, however, to determine approximately the proportion of protein which is rendered soluble and absorbed by the animal body. Digestion experiments of this sort were made by Dr. C. L. Alsberg. His method and results are as follows:

Mussels, hard-boiled eggs (yolk and white together), and thoroughly boiled beef were each ground up in an ordinary kitchen sausage machine. Each chopped-up sample was thoroughly mixed to make it as uniform as possible. Then 5-gram samples were weighed out. Each sample was placed in a flask containing 100 c. c. of artificial gastric juice. This juice was prepared by dissolving 0.5 gram pepsin in 1 liter 0.15 per cent hydrochloric acid. All the flasks were placed in a thermostat at a temperature of 38° C. At stated intervals they were all shaken by hand. After two hours one-half the flasks were removed from the thermostat. The remainder were removed after four hours. Immediately after taking them out of the thermostat each flask was brought to a boil in order to destroy the enzymes. Each was then filtered through an ash-free quantitative filter, and when all the liquid had passed through the filter the undissolved residue was washed with 100 c. c. of distilled water. When all the wash water had passed through the filter, the amount of nitrogen was determined by the Kjeldahl method in the combined filtrate and wash water as well as in the undissolved residue. From the relative amounts of nitrogen in the filtrate and undissolved residue an opinion may be formed as to how much protein has been rendered soluble by the action of the gastric juice. This method is not accurate, but it is believed to be more accurate than the methods commonly employed, in which the various digestion products are precipitated out and weighed. The washing and drying of such proteins upon filters presents great difficulties. It is believed that the determination of the nitrogen rendered soluble gives a better index of the effect of the digestion. The figures obtained were multiplied by 6.25 to indicate the amount of protein corresponding to them. The resulting figures are given in the following table, each figure representing the average of several experiments:

TABLE I.—RESULTS OF EXPERIMENTS TO SHOW AVAILABLE PROTEIN IN MUSSELS.

Substance.	Protein in filtrate.	Protein in residue.	Per cent dissolved.
<i>For two hours' digestion:</i>			
	<i>Grams.</i>	<i>Gram.</i>	
Mussels	0.5783	0.2012	74.1
Egg6168	.1866	76.0
Beef	1.1656	.2705	81.1
<i>For four hours' digestion:</i>			
Mussels6107	.1522	80.0
Egg7455	.2104	77.9
Beef	1.2930	.1450	96.7

It will be seen that under the conditions of these experiments there was no very great difference in the digestibility of the egg and the mussels, while the beef was considerably more digestible than either. It must, however, be pointed out that beef has more nitrogenous extractives than egg and that the greater digestibility of the beef may be accounted for in part by the fact that under the conditions of these experiments the nitrogenous extractives are calculated as protein. How much nonprotein nitrogenous extractives mussels contain is not known. It must be noted, however, that, judged by sight, the greater part of the mussels went into solution. The undissolved portions consisted mainly of the tough portions, such as the foot and posterior adductor muscle.

Finally, it should be pointed out that experiments such as these must be interpreted cautiously. Digestion *in vitro* is surely not so effective as digestion in the intestinal canal. It is even probable that in the intestinal canal all these three foodstuffs may be equally perfectly utilized. This can be determined by careful metabolism experiments.

METABOLISM EXPERIMENTS.

The metabolism experiments were made a special subject of research by Dr. Donald D. Van Slyke, assisted by Messrs. W. M. Clark and C. B. Bennett. In Doctor Van Slyke's report, which follows, the rate of digestion and proportion of nutriment absorbed from cooked mussels and squid is compared with that of beef as a standard:

The work outlined was undertaken to determine the comparative rapidity and completeness with which various sea foods are digested, absorbed, and utilized in the animal organism and the effects of different modes of preparation and preservation upon the food value. The substances were compared with beef as a standard. The experimental animal was a fox terrier bitch of 12½ pounds weight. While more valuable results, from a practical standpoint, might be obtained from experiments on men, the latter could not tolerate for a long time the simple diet used, nor be subject to regular catheterization. The experiments, furthermore, were for comparison of the behavior of different protein foods under the same conditions, and it is probable that the foods would rank in the same order when tested in dogs or in men, although the absolute completeness and rapidity of utilization varies with different species and individuals.

PRINCIPLES OF METHODS.

The daily rations were so proportioned, from analyzed foods, that the dog obtained just the amount of protein required to maintain nitrogenous equilibrium. Fats and carbohydrates were also kept constant. The amount of protein digested was calculated from analysis of the food and feces, the nitrogen in the latter being ascribed to undigested protein. The rate at which the protein is digested, absorbed, and utilized is measured by the rate at which its nitrogen is excreted in the urine.

METHODS IN DETAIL.

The dog was brought to nitrogenous equilibrium by feeding on a constant diet of cracker dust, lard, lean beef, and salt. In the experiments with fish flesh, the beef was replaced by an amount of steamed fish meat. The fish was cleaned and the flesh steamed immediately after the fish was caught, in order to prevent autolytic or bacterial changes. The remainder of the ration was the same as in the beef diet, except the amount of lard was reduced in proportion to the fat content of the fish flesh, so that the fat content of the ration was kept the same as in the standard beef diet. All foods were analyzed for nitrogen and fat. On alternate days animal charcoal was mixed with the ration, in order that the feces from food consumed on successive days might be separated by their colors. In case the entire daily ration was not consumed, the remainder was fed through a tube.

The animal was catheterized immediately before feeding the day's ration, and at three-hour intervals thereafter for twelve hours, then again at the end of twenty-four hours after feeding, the bladder being washed out with 0.6 per cent sodium chloride solution at each catheterization. The nitrogen excreted in the urine during each interval was determined by Kjeldahl analysis. The urine obtained at each catheterization, combined with the cage washings in case the dog had urinated during the interval, was acidified with sulphuric acid, diluted to 500 or 1,000 volumes, and one-twentieth taken for analysis.

The feces containing the undigested portions of each day's rations were collected and the nitrogen content determined. The animal charcoal in the alternate day's feces made a separation possible, and the 5 grams of bone ash fed daily insured a well-formed, solid stool.

It was found that analysis of both food and feces for nitrogen and fat could be made accurately without preliminary drying in a dessicator. For fat analysis about 10 grams of the fresh material were ground up with anhydrous copper sulphate until the mixture became a dry, homogeneous powder. This was extracted for about ten hours with carbon tetrachloride, ground again, and reextracted for a few hours. Representative samples of flesh for nitrogen determination were obtained by grinding the flesh as fine as possible in a meat grinder, and taking 2 grams or more for the sample.

The daily diet consisted of 25 grams of fat, 50 grams of cracker dust, and sufficient beef or fish flesh to bring the total nitrogen of the diet up to the amounts indicated in the table. About three-fourths of the protein ration was contained in the flesh, the other one-fourth in the cracker dust. To the lard, cracker dust, and meat were added 5 grams of sodium chloride and 5 grams of bone ash.

After being fed squid for two days, the dog refused to consume completely the rations offered and was partially starved for several days. During the feeding of raw beef and squid she consumed and excreted 2.5 grams of nitrogen daily, as indicated in the two lower curves of the figure.

The results are briefly indicated by the following tables and figure.

TABLE 2.—SHOWING RESULTS OF METABOLISM EXPERIMENTS.

	Ration containing—			
	Raw beef.	Steamed squid.	Steamed beef.	Steamed mussel.
Nitrogen in ration (grams).....	2.497	2.505	2.085	2.131
Nitrogen excreted in feces423	.291	.285	.444
Nitrogen digested.....	2.074	2.214	1.800	1.687
Per cent nitrogen digested.....	83.1	88.4	86.3	79.1

	Ration containing—			
	Raw beef.	Steamed squid.	Steamed beef.	Steamed mussel.
Nitrogen in ration (grams).....	2.497	2.505	2.085	2.131
Nitrogen in urine +feces	2.489	2.485	1.910	2.117
Nitrogen retained.....	+0.01	+0.02	+0.18	+0.01

CONCLUSION.

The above results indicate (table 2) that the protein of the ration containing steamed mussel was digested somewhat less completely (79.1 per cent) than that of raw beef (83.1 per cent), while the squid gave higher results (88.4 per cent) than the raw beef. The steamed-beef figures (in table, not in the figure) are of doubtful accuracy, as a portion of the feces may have been lost, causing the high figures for digestibility (exceeding those of raw beef, which is improbable) and for nitrogen retention. The digestibility figures indicate only the relative digestibility of the meats fed. A considerable

proportion of the undigested (fecal) nitrogen is due to the cracker-dust protein, which is known to be less digestible than ordinary flesh proteins. Consequently, in order to determine the digestibility of the meat proteins alone, a correction must be applied for the undigested vegetable protein. Unfortunately, we lacked time to determine this correction.

The urine curves must be considered in pairs, because the amount of nitrogen given in the raw-beef and steamed-squid diets was greater than that given later in the steamed-beef and mussels ration. The beef and squid (upper) curves show that the beef protein was metabolized more rapidly, as the beef curve rises more rapidly after feeding. The difference is not great, however, and the total amount of squid nitrogen metabolized and excreted in the urine in twenty-four hours is slightly the greater, coinciding with the fact that less squid nitrogen was found in the feces. Apparently squid proteins are digested slightly less rapidly than those of beef, but more completely.

The steamed-beef and *Mytilus* curves show a similar relation, the beef being metabolized more rap-

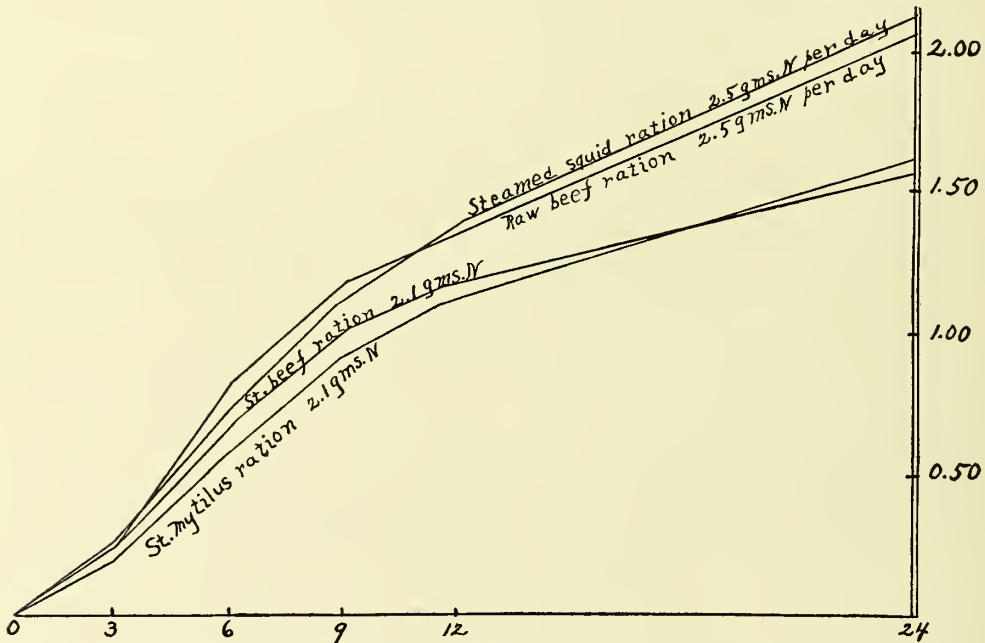

FIG. 1.—Curves showing results of metabolism experiments. Figures on base line indicate number of hours since feeding. Figures in vertical line at right show number of grams of nitrogen excreted in urine.

idly in the hours immediately following feeding, the *Mytilus* curve overtaking and passing the beef curve later, however.

The raw-beef figures are taken from three successive days' results, the figures for the other meats from the results of two days' experiments each. The brief time (less than three weeks) available precluded longer tests, which would have been desirable, and limited the experiments to those above reported. They must be regarded as merely preliminaries to a thorough investigation of the problem.

It is clear, from the evidence just presented, that the mussel measures up well to the standard of digestibility. It agrees well with the consumer and the rate of digestion and proportion of nutrients supplied to the body approximate very nearly those of steamed beef.

COMPOSITION AND NUTRITIVE VALUE.

The function of food is to build up new tissues and repair them as they are worn out by use, to supply heat energy for keeping the body warm and muscular energy for doing work. The nutritive value or degree to which a food material is able to perform this function depends upon two factors, (1) the ratio of edible portion to refuse and (2) the relative amounts of nutrients contained in the edible portion. The first of these is determined by separating the flesh and liquor from the shells and byssus of the mussels, then weighing them separately and determining the percentage of each present. The second factor is determined by means of a chemical analysis of the edible portion.

The nutrients sought represent four classes of compounds: (1) Protein, which forms the nitrogenous basis of blood, muscle, connective tissue, etc.; (2) carbohydrates; (3) fats, which may be stored up as fat or consumed for fuel; and (4) mineral matters or ash, which are used chiefly in the formation of bone.

In studying the ratio of edible portion to refuse two sets of determinations were made. One was based on the examination of fresh or uncooked specimens and the other on mussels which had been cooked by steam. In the first case the mussels were weighed after being washed free from dirt. They were then quickly shucked and "bearded," the meats and liquor being preserved in separate dishes. What liquor adhered to the flesh was drained off and added to the other dish. The weights of the flesh and liquor were ascertained and recorded. The total weight of the mussels minus the combined weights of the flesh and liquor was considered the amount of refuse matter. This method, it will be observed, places the loss due to handling in the refuse column. The results obtained from the examination of five separate lots of mussels will be found in the following table:

TABLE 3.—SHOWING PROPORTION OF EDIBLE PARTS TO REFUSE IN THE SEA MUSSEL.

Determinations from fresh or uncooked material.

Date.	Number taken.	Total weight.	Average weight.	Flesh.	Liquids.	Total edible portion.	Refuse.	Flesh.	Liquids.	Total edible portion.	Refuse.
1908.		<i>Lbs. oz.</i>	<i>Ounces.</i>	<i>Lbs. oz.</i>	<i>Lbs. oz.</i>	<i>Lbs. oz.</i>	<i>Lbs. oz.</i>	<i>Per ct.</i>	<i>Per ct.</i>	<i>Per ct.</i>	<i>Per ct.</i>
July 10.....	50	5 4	1.68	1 8½	1 6½	2 14½	2 5½	28.87	26.78	55.65	44.35
July 13.....	100	9 13	1.57	2 13½	2 8	5 5½	4 7½	28.75	25.48	54.23	45.77
August 8.....	50	4 5½	1.39	1 1½	1 1	2 1½	2 3½	25.35	23.74	49.09	50.91
August 26.....	20	2 3½	1.76	0 9½	0 10½	1 3½	0 15½	26.10	29.00	55.10	44.90
August 28.....	11	1 1½	1.68	0 5½	0 4½	0 9½	0 7½	30.80	25.00	55.80	44.20
Total.....	231	22 11½	1.57	6 5	5 13½	12 2½	10 8½	27.79	25.75	53.54	46.46

In the second case the total weight, as above, was taken after washing the mussels free from dirt, but before removing the meats and liquor the shellfish were cooked by means of steam until the shells began to open. This treatment gives very different results from those obtained from the raw material, as may be seen in the following:

TABLE 4.—SHOWING PROPORTION OF EDIBLE PARTS TO REFUSE IN THE SEA MUSSEL.

Determinations from steamed material.

Date.	Number taken.	Total weight.	Average weight.	Flesh.		Liquids.		Total edible portion.		Refuse.		Flesh.		Liquids.		Total edible portion.		Refuse	
				Lbs. oz.	Ounces.	Lbs. oz.	Lbs. oz.	Lbs. oz.	Lbs. oz.	Lbs. oz.	Lbs. oz.	Per ct.	Per ct.	Per ct.	Per ct.				
1907.																			
August 12.....	119	10 0	1.34	2 2½	1 8	3 10½	6 5½	21.56	15.00	36.56	63.44								
Do.....	167	15 0	1.44	2 15	1 2	4 1	10 15	19.58	7.50	27.08	72.92								
August 13.....	186	16 0	1.38	3 4	1 11	4 15	11 1	20.35	10.54	30.89	69.11								
Do.....	192	16 0	1.33	3 3	1 14	5 1	10 15	19.92	11.71	31.63	68.37								
August 14.....	204	17 0	1.33	3 8	2 2	5 10	11 6	20.58	12.50	33.08	66.92								
August 15.....	213	18 0	1.35	3 13	2 6	6 3	11 14	21.18	13.19	34.37	65.63								
August 26.....	180	16 0	1.42	3 1	1 12	4 13	11 3	19.14	10.97	30.11	69.89								
August 27.....	330	25 0	1.21	5 9	2 10	8 3	16 13	22.25	10.50	32.75	67.25								
August 28.....	88	9 0	1.63	1 9½	0 8	2 1½	6 14½	17.71	5.55	23.26	76.74								
1908.																			
July 9.....	91	9 1	1.60	1 13	0 10	2 7	6 10	20.00	6.89	26.89	73.11								
July 12.....	218	23 3	1.70	4 1	1 14	5 15	17 4	17.52	8.09	25.61	74.39								
July 15.....	106	12 0	1.81	2 6	0 15	3 5	8 11	19.79	7.81	27.60	72.40								
July 16.....	356	36 0	1.61	6 9	2 12	9 5	26 11	20.34	7.63	27.97	72.03								
July 30.....	356	31 8	1.44	5 7	2 10	8 1	23 7	17.26	8.33	25.59	74.41								
August 8.....	287	32 5	1.80	4 12	1 15	6 11	25 10	14.70	5.99	20.69	79.31								
August 10.....	212	20 3	1.52	2 15	0 15	3 14	16 5	14.55	4.64	19.19	80.81								
August 11.....	180	18 0	1.60	2 5	0 12	3 1	14 15	12.84	4.16	17.00	83.00								
August 14.....	744	74 12	1.60	15 12	9 3	24 15	49 13	21.15	12.29	33.44	66.56								
Total.....	4,229	399 0	1.50	75 1	37 3	112 4	286 12	18.81	9.32	28.13	71.87								

A comparison of the two tables reveals a wide difference in the ratios of edible parts to waste. In case of the raw material it is 53.54 per cent of meat and liquor to 46.46 per cent of refuse. With the cooked material it is 28.13 per cent to 71.87 per cent. This great dissimilarity of results is due to two facts. In the first place, cooking removes considerable water from the flesh and in the second place the opening of the shells of many of the mussels during the process of cooking causes considerable loss of the natural liquor. The loss of water and liquor is thus added to the refuse column and makes the difference between the useful and waste parts appear greater than it really is. These figures apparently indicate that much loss of food material results from cooking, but such is not the case. The loss in weight is due almost entirely to the extraction of water.

A comparison of the mussel with the oyster and long clam on the basis of the relative amounts of edible parts to refuse will help one to appreciate its real value as a food. The figures used for this purpose are taken from Atwater (1891) and incorporated in the following table:

TABLE 5.—SHOWING PERCENTAGE OF EDIBLE PARTS AND REFUSE IN THE MUSSEL, LONG CLAM, AND OYSTER.

Kinds of shellfish.	Number of specimens.	Edible portion.			Refuse (shells, etc.).
		Flesh.	Liquids.	Total.	
Sea mussel.....	50	32.66	18.00	50.66	46.69
Long clam.....	441	34.77	21.78	56.55	41.77
Oyster.....	3,383	9.81	7.65	17.46	81.40

Measured by the above standard, the mussel contains about the same proportion of flesh and liquids as the long clam and about three times as much as the oyster. If

the flesh of each species contained the same amount of nutrients we might conclude that for equal weights of the shellfish the food value of the mussel is about equal to that of the long clam but three times that of the oyster. This obvious superiority over the oyster is due to the thin, light shell of the mussel, which stands in sharp contrast to the heavy, thick shell of the oyster. A consideration of the chemical composition of these forms, however, will show that the difference in food value between the mussel and oyster is even greater than is indicated by the above table.

The account which follows is taken from Doctor Alsberg's personal report to me. In view of the fact that the methods used in making the analyses differ in some important particulars from those employed by Atwater (1891), with whose results comparisons are made, it is necessary to describe them briefly.

In preparation of a sample a large quantity of the mussel meats was ground up in a meat chopper and the ground-up sample thoroughly mixed. Of this, a small sample of 50 grams was weighed out into a weighed glass dish. Enough sulphuric acid was added to make the reaction neutral. As the reaction of the juices of invertebrates is very alkaline, this is a most important matter. If it is neglected, much nitrogen is lost as ammonia. This precaution has apparently not been taken by Atwater or anyone else. Probably Atwater's figures for oysters are too low for this reason. Doctor Alsberg's high nitrogen values are probably in part due to this method. The glass dish containing the 50 grams of neutral material was then evaporated to dryness on the steam bath, with care that the reaction remained neutral. Atwater dried in a stream of hydrogen. There were no facilities for doing this in the present work, but it is thought that the results are unaffected, except to a slight extent for the fat determinations.

The material thus dried was very difficult to pulverize, partly because of the fat content, which made it greasy, and partly because invertebrates contain hygroscopic salts. Therefore the material was boiled out with 95 per cent alcohol until the latter was colorless. The alcoholic solution was made up to a known volume and analyzed by itself. The results were added to those obtained from the residue. The sum of the two gives the figures for the total. The residue from the alcohol was easily ground up and sampled in an agate mortar. The material for all the determinations was weighed out at the same time. In addition, about 1.50 grams were weighed in a weighing bottle and dried at 60° C. in vacuo over sulphuric acid in a Schmiedeberg drying apparatus. In this way the total quantity of water was determined and the determinations calculated accordingly. The water determinations are therefore more correct than those of Atwater.

The fat determinations were done by extracting with carbon tetrachloride (CCl₄) in a Soxhlet apparatus. It was not safe to use ether, as Atwater did, because of the danger of fire in a wooden building. As carbon tetrachloride is a better solvent than ether, the figures obtained are naturally a little higher than those of Atwater. Another reason why they are higher is that the material was not dried in hydrogen.

Nitrogen was determined by the Kjeldahl method, which had not been discovered in Atwater's time. He used the soda-lime method, which is probably as good.

Atwater made no determinations of carbohydrates. Inasmuch as the oyster contains much glycogen, an attempt was made to determine glycogen in the mussel. This

was done by Pflüger's method in its latest modification. One hundred grams of absolutely fresh material were used and the determination begun at once to prevent the hydrolysis by enzymes. The purified glycogen was determined in three ways: (1) It was filtered through a weighed Gooch crucible, dried, and weighed. It was then ashed and the crucible weighed again. The weight of the ash, which was always under 2 per cent, was then subtracted, and the resulting figures are those given in the table. (2) The glycogen was then hydrolyzed with dilute sulphuric acid and the sugar determined titrimetrically with Fehling's solution. (3) The glycogen was hydrolyzed with dilute sulphuric acid and the resulting sugar determined in the polariscope.

The figures for flesh calculated on fresh substance do not quite total 100 per cent. This is probably not due to errors in methods or technique, but to errors of calculation. Thus the proteins are calculated arbitrarily. It is assumed that all nitrogen is present as protein, whereas as a matter of fact some is in the form of extractives and some in the form of fats (lipoids). It is assumed, further, that the proteins of mussels have the same nitrogen content as those of vertebrates. As they have not been investigated, this is an arbitrary assumption, and the factor 6.25 may be wrong. Moreover, as some of the nitrogen is in the fat (lipoids), this figures twice in the tables, once as protein and once as fat. The crude ash, too, does not quite correctly represent the inorganic substances of the mussel, because in the process of ashing some is volatilized, while new phosphoric acid and sulphuric acid are formed from the protein. All these, however, are errors inherent in all analyses of this nature.

The structure of the flesh of male and female mussels being very different (compare figs. 2 and 3, pl. XXIII), separate analyses were made of the two sexes. The distinction of the sexes was based on the color of the mantle, white flesh being called male and red flesh female. This method of separation is, however, not absolutely accurate. Microscopic examination revealed the fact that in about 2 per cent of the cases a red mussel might be a male and a white or cream-colored one a female. The results of the analyses are as follows:

TABLE 6.—SHOWING COMPOSITION OF MUSSELS CALCULATED FOR WATER-FREE SUBSTANCE.
[August 15, 1908.]

Ingredients.	White flesh (male).	Red flesh (female).	Average for white and red flesh.
<i>In flesh:</i>	<i>Per cent.</i>	<i>Per cent.</i>	<i>Per cent.</i>
Nitrogen.....	9.35	10.75	10.05
Protein (N×6.25).....	58.44	68.18	63.31
Fat, CCl ₄ Ext.....	8.51	12.01	10.26
Carbohydrate.....	13.61	9.41	11.51
Crude ash.....	6.74	6.03	6.38
<i>In liquids:</i>			
Nitrogen.....			3.62
Protein (N×6.25).....			22.62
Fat, CCl ₄ Ext.....			.28
Carbohydrate.....			Trace.
Crude ash.....			65.50
<i>In total edible portion:</i>			
Nitrogen.....			9.19
Protein (N×6.25).....			57.43
Fat, CCl ₄ Ext.....			8.93
Carbohydrate.....			9.97
Crude ash.....			14.27

TABLE 7.—SHOWING COMPOSITION OF MUSSELS CALCULATED FOR FRESH SUBSTANCE.

[August 15, 1908.]

Ingredients.	White flesh (male).	Red flesh (female).	Average for white and red flesh.
<i>In flesh:</i>	<i>Per cent.</i>	<i>Per cent.</i>	<i>Per cent.</i>
Water.....	76.62	76.18	76.40
Nitrogen.....	2.44	2.46	2.45
Protein (N×6.25).....	15.25	15.38	15.31
Fat, CCl ₄ Ext.....	1.98	3.10	2.54
Carbohydrate.....	3.19	2.24	2.71
Crude ash.....	1.58	1.44	1.51
<i>In liquids:</i>			
Water.....			95.64
Nitrogen.....			.16
Protein (N×6.25).....			.99
Fat, CCl ₄ Ext.....			.01
Carbohydrate.....		
Crude ash.....			2.86
<i>In total edible portion:</i>			
Water.....			83.27
Nitrogen.....			1.63
Protein (N×6.25).....			10.18
Fat, CCl ₄ Ext.....			1.64
Carbohydrate.....			1.74
Crude ash.....			1.99

The above figures indicate that, for a shellfish, the mussel contains a high percentage of each of the four classes of food materials and that the white-fleshed individuals (males) differ considerably in chemical composition from the red-fleshed ones (females), the latter containing a much higher percentage of protein and fat but less carbohydrate. This difference is accounted for by the fact that the whole body of the female, during the spring and summer, is distended with eggs which are rich in yolk material. It is during this season, therefore, that the mussels are at their best as a food.

A fair idea of the food value of the mussel may be obtained by comparing its fuel value with those of several standard food materials, e. g., oysters, long clams, and beef. Fuel value refers to the number of calories of heat equivalent to the energy which the body is supposed to obtain from 1 pound of a thoroughly digested food material. The fuel values of various food materials are calculated by using the factors of Rubner, which, in terms of the English system of weights, correspond to 1,860 calories of energy for every pound of protein or carbohydrate and 4,220 calories for each pound of fat.

TABLE 8.—SHOWING COMPARATIVE FUEL VALUES OF MUSSELS, OYSTERS, LONG CLAMS, AND LEAN BEEF.

Food materials.	Refuse.	Water.	Protein (N×6.25).	Fat.	Carbohy- drate.	Ash.	Fuel value per pound.
	<i>Per cent.</i>	<i>Per cent.</i>	<i>Per cent.</i>	<i>Per cent.</i>	<i>Per cent.</i>	<i>Per cent.</i>	<i>Calories.</i>
Mussels, in shell.....	46.69	41.1	5.0	0.8	0.85	140
Mussels, edible portion.....	83.3	10.18	1.64	1.74	1.99	290
Oysters, in shell ^a	81.4	16.1	1.2	.2	.7	.4	45
Oysters, edible portion.....	86.9	6.2	1.2	3.7	2.0	235
Long clams, in shell ^a	41.9	49.9	5.0	.6	1.1	1.5	140
Long clams, edible portion.....	85.8	8.6	1.0	2.0	2.6	240
Beef, hind quarter as purchased ^a	16.6	55.3	16.7	11.28	785

^a From calculations of Atwater and Bryant (1906).

A comparison of the fuel values of the mussel and oyster based on the total weight of waste and edible portions shows that the value of the mussel as a food is three times greater than that of the oyster. The ratio between the fuel values of the edible portions of these two shellfish is more nearly equal, but the mussel in this case is superior to the oyster by 65 calories per pound. The fuel values of the mussel and long clam are about the same. Compared with lean beef we might say that $5\frac{1}{2}$ pounds of mussels in the shell, or $2\frac{3}{4}$ pounds of meats and liquor in their natural proportion, are equal in food value to 1 pound of beef.

As a food material, therefore, from the standpoint of chemical composition and nutritive value, the mussel is far superior to the oyster, is equal to the long clam, and has about one-third the value of lean beef.

MUSSELS A CHEAP FOOD.

Measured by the fourth standard, economy, we again find the mussel taking high rank among food materials. It is widely distributed, extremely abundant, and easily obtained. Mussels abound in the bays and estuaries of our Atlantic coast from North Carolina northward and on our Pacific coast from Alaska to San Francisco. They grow in great beds, often acres in extent, on the surface of mud or sand extending out from between tide marks to several fathoms of water. Plate xxiv, figure 1, is a view of an exposed mussel bed at Menemsha Pond, Marthas Vineyard, Mass. This bed is but two years old and represents hundreds of tons of valuable food. Mussels are also found growing in great abundance out in the deeper waters. On one occasion in Vineyard Sound, not far from Robinsons Hole, the steamer *Fish Hawk* dredged up a beam trawl full of them, a quantity approximating a ton or more. A resident of Pawtucket, R. I., writes that there are places in Narragansett Bay where a man could obtain 50 bushels a day for the whole season if he had a partner to receive and dispose of them. Under these conditions he considers 35 cents a bushel a reasonable price to ask. The total supply of New York City, which amounts to 75 barrels of mussels in the shell and 400 gallons of the pickled variety per day, is furnished chiefly from the bays bordering Long Island. The man who provides nearly this whole supply informed me that the quantity of mussels is far in excess of the demand.

As has already been shown, the mussel breeds at an almost inconceivable rate and grows very rapidly. Even if the demand should grow to exceed the supply from the natural beds it would be an easy matter to meet the increase by means of cultivation. The methods which may be utilized for this purpose are discussed in another chapter.

The question of real economic importance to the consumer of food is the ratio between the cost of a given food and the amount of nutriment it supplies. Milner (1903) groups food materials into three classes: (1) Cheap, those which furnish more than 1,900 calories energy for 10 cents at ordinary prices; (2) Medium, those which furnish 800 to 1,900 calories energy for 10 cents; and (3) Expensive, those furnishing less than 800 calories energy for 10 cents. A bushel of mussels weighs about 70 pounds.

At 35 cents a bushel the rate would be half a cent per pound, or 10 cents for 20 pounds. In table 8 we find the fuel value for each pound of mussels in the shell to equal 140 calories energy. $20 \times 140 = 2,800$ calories energy, the amount 10 cents would purchase at 35 cents per bushel. This, however, is calculated on the wholesale price. The retail cost would probably be double this amount. Consequently, our fuel value should be cut in half, making 1,400 calories energy the purchasing value of 10 cents at retail rates. Thus the calculation on wholesale prices places the mussel in the class of cheap foods. The calculation on retail prices puts it among the cheaper of the medium-priced foods, such as beef flank, neck and shank, milk, beans, and turnips.

To thousands of families who live near the coast, the mussels are to be had for the slight effort required to gather them, and yet up to the present time all this vast wealth of food has been ignored and wasted. This, too, where families in easy reach of a rich supply of the shellfish are facing poverty.

PRESERVATION METHODS.

At the present time there is great need for methods of preserving perishable foods in such a manner as not to injure their palatable flavor and nutritive qualities or greatly increase the price at which they may be sold to the consumer. Especially is this true for fishery products, which spoil very quickly after removal from the water. The decomposition which sets in so rapidly is caused by the presence of bacteria, which multiply with great rapidity, the rate of putrefaction progressing in direct proportion to their increase in number.

To preserve fishery products, then, it is necessary to keep them free from the action of bacteria, and this may be accomplished by eliminating one or more of the three conditions on which the life and growth of the organisms depend—namely, heat, moisture, and oxygen. Cold storage deprives the organisms of sufficient heat for growth, desiccation takes the needed moisture from them, and canning at high temperatures destroys the germs present and, furthermore, excludes the air required for growth. Antiseptics, such as salt, vinegar, and boracic acid, are employed to prevent the multiplication of bacteria. All of these methods are applicable to the mussel.

CANNING.

The sea mussel is of all the shellfish particularly adapted for canning. Unlike the oyster, it remains tender and retains its full flavor when subjected to the high temperatures necessary to prepare it in this way. The process which has been devised as most feasible is as follows:

The mussels when taken from the collecting boats are rapidly picked over by hand to eliminate any dead or unhealthy ones which may be present, as well as the coarse adhering débris. Then they are placed in a cleaning apparatus, such as is shown in figure 2. It consists of a rectangular box 2 by 2 by 3 feet, which revolves on its long axis. The ends of the box are of solid yellow pine and are firmly held in place by four pairs of braces 3 feet long, 2 inches wide, and $\frac{1}{2}$ inch thick. Three sides of the box are

inclosed with $\frac{3}{4}$ -inch mesh galvanized wire netting. The fourth side has a door 8 inches wide, running the length of the box. The door is clamped firmly in place by means of a lever, which is swung over it. The rest of the side is filled in with parallel strips of wood placed one-half inch apart. The projecting ends of the axis rest on the walls of a trough $1\frac{1}{2}$ feet deep, in which there is running sea water. A crank at one end serves as a means to rotate the cage.

About 1 bushel of mussels is placed in this cleaning apparatus, which is set in rotation at the rate of 30 revolutions a minute for fifteen minutes. The treatment cleans off from the shells all clinging sea weeds, sand, and débris, besides breaking open the

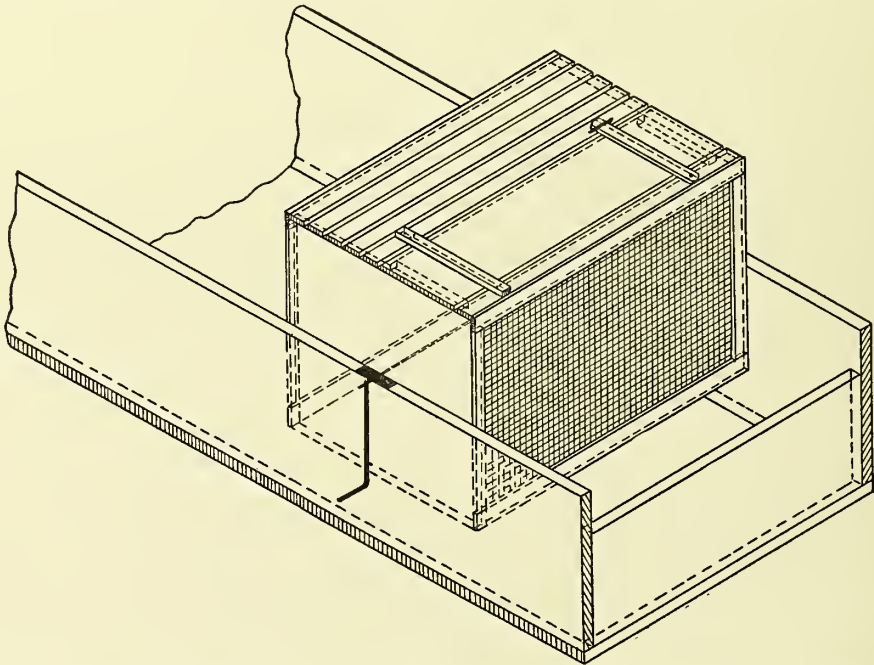

FIG. 2.—Apparatus for cleaning mussels preparatory to canning or other preservation process. (Drawn for the author by Prof. L. C. Harrington.)

shells of dead mussels and washing away the injurious substance contained within them. In the experimental work this method of cleaning mussels proved very effective. For cleaning on a commercial scale the device may easily be constructed on larger dimensions and operated by means of steam or water power.

After this treatment the mussels are removed and rinsed off with clean water. They are placed in a chest and subjected to live steam for from five to ten minutes, or until the shells begin to open. They are next emptied out into shallow pans to cool and the natural liquor which has escaped into the chest is preserved in a separate dish.

As soon as they are cool enough to be handled, the mussels are shucked and the horny "beard" removed, the meats and liquor being preserved in separate dishes.

While the liquor taken from the steam chest and that taken from the mussels during the process of shucking is filtering through a fine-meshed cloth, the mussel meats are packed in glass jars or bottles. The filtered liquor is brought to a boil and 2 ounces of salt are added for each gallon. The jars containing the meats are then filled with the boiling liquid and sealed. To insure complete sterilization, the sealed jars are placed in a steam chest and subjected to 5 pounds pressure for fifteen minutes. They are allowed to cool down slowly and when the temperature has fallen to about 100° F. they are removed and set aside for future use.

Persons wishing to can mussels for use in their own homes and who lack the facilities described in this process, may do so by modifying the method in the following way: After thoroughly cleaning the outsides of the mussels by means of a stiff-bristled brush, rinse them in clean water and place them in a large, closely-covered kettle with a little water covering the bottom—about one cup of water to each gallon of mussels. Place on the stove and bring to a boil, continuing the cooking for about fifteen minutes or until the top shells have opened. Pour out the liquor that has collected in the bottom of the kettle and preserve it in a separate dish from the mussels. Shuck the mussels, being careful to remove the byssus or horny tuft of threads growing out from the base of the foot. While the liquor is filtering through a fine-meshed cloth pack the meats in pint or half-pint glass jars of the ordinary household type. To each quart of the filtered liquor add one heaping teaspoonful of salt and bring it to a boil. Pour the boiling liquid over the mussel meats, filling the jars to the brim, and then quickly clamp or screw on the lids. The jars should next be placed in a large vessel, such as a wash boiler, containing boiling water, and left to boil for at least half an hour. At the end of this time the vessel with its contents should be removed to the back of the stove and allowed to cool. As soon as convenient the jars may be removed and the tops tested to see that they are sealed air tight. Treated in this manner, the mussels ought to keep for many months and preserve their natural flavor. When desired for use on the table they may be prepared according to almost any of the methods employed in preparing the fresh mussels for food.

PICKLING.

At the present time, in the United States, the pickling of mussels is the only form of preservation in use. As an article of trade they are known only to New York City and vicinity, one man supplying most of the demand with 400 gallons per day. They are eaten both by Americans and foreigners. The process for preservation by pickling involves the use of vinegar and spices in various proportions according to individual fancies. In my own experience I have found the following formula most satisfactory in results:

After thoroughly washing the mussel shells in the cleaning apparatus already described, the mussels are placed in a steam chest for about ten minutes, or until the shells have opened. They are then shucked, the liquor and meats being preserved in separate vessels. Care should be taken to see that the horny filament or "beard" is removed from the base of the foot. For each quart of natural liquor there is added 1 pint of vinegar, $\frac{1}{2}$ ounce of allspice, $\frac{1}{2}$ ounce of cinnamon, $\frac{1}{4}$ ounce of cloves, $\frac{1}{4}$ ounce of salt, and 1 small red pepper. The mixture is allowed to simmer upon the stove for fifteen minutes and is then poured over the meats. After standing about twenty-four hours the meats are removed from the spiced liquor and are neatly packed in bottles or fruit jars. The liquor after being filtered through a fine-meshed cloth, to remove the undissolved spices and sediment that is formed, is heated to boiling and poured over the meats until the jars are brimming full. The jars are sealed air tight and placed in a steam chest, where they are subjected to 5 pounds steam pressure for fifteen minutes.

After this treatment they will remain in a good state of preservation for about two years. If the pickled mussels are desired for immediate consumption, it is not necessary to seal them up in jars. They may be kept a week or more in open tubs without deteriorating. If kept much longer than this, they gradually turn dark and fall to pieces. A New York dealer told me that he was able to sell pickled mussels in the tub at 35 cents per gallon, but this gave him very little profit.

DRYING.

The preservation of mussels by means of desiccation is a problem to which I have devoted considerable attention. So far the efforts have been hardly successful enough to make mention of them in this report. A few words concerning the difficulties involved in the process, however, and some observations may be of value. The problem to solve in drying mussels for food is to regulate the process, so that the flavor of the meats is not impaired nor the appetizing odor lost.

The plan originally employed was to clean the mussels, steam and shuck them by the method already described, and transfer the meats to an artificial dryer, which consisted of a large chamber, 3 by 5 by 6 feet, tapering off at the top into a flue. Two drawers with galvanized wire bottoms extended into this chamber. A current of air was forced by means of a 24-inch fan over a hot radiator into the bottom of the chamber, from whence it passed upward through the meshed drawer bottoms and over the substance to be dried. The temperature of the air as it passed over the drying flesh was 50° C., or 122° F. Material subjected to this treatment dries very rapidly, even in the very humid atmosphere of Woods Hole, Mass. In from seven to twelve hours mussel flesh treated thus will lose 70 per cent of its weight. The accompanying table of 12 experiments indicates that after seven hours' drying most of the water which it is possible to extract by this method has been removed.

TABLE 9.—SHOWING LOSS OF WEIGHT IN MUSSELS DUE TO DRYING.

Date.	Weight of flesh.	Time in dryer.	Weight after drying.	Per cent of loss.	Per cent remaining.
	<i>Ounces.</i>	<i>Hours.</i>	<i>Ounces.</i>		
1907.					
August 28.....	10 $\frac{5}{8}$	13	3 $\frac{1}{4}$	69.4	30.60
August 29.....	25	15	5 $\frac{3}{8}$	79.5	20.50
August 30.....	60	7	17 $\frac{1}{2}$	70.83	29.17
1908.					
July 9.....	29	12	7 $\frac{5}{8}$	73.71	26.29
July 10.....	24 $\frac{1}{4}$	14	6 $\frac{3}{4}$	72.13	27.87
July 12.....	65	20	23 $\frac{3}{8}$	64.04	35.96
July 15.....	^a 42	25	9 $\frac{3}{4}$	76.79	23.21
July 16.....	105	18	36 $\frac{1}{4}$	65.48	34.52
August 10.....	47	17	14 $\frac{1}{8}$	69.95	30.05
Do.....	37	19	11 $\frac{3}{4}$	68.24	31.76
August 26.....	24	20	6 $\frac{3}{4}$	71.84	28.16
August 28.....	30	22	7 $\frac{1}{2}$	75.00	25.00
Total.....	499 $\frac{1}{8}$	^b 16 $\frac{5}{8}$	149 $\frac{1}{4}$	69.99	30.01

^a Had been salted down 15 hours.^b Average length of time in the dryer.

The product of this treatment is a brown brittle substance with an unappetizing look and odor. The appearance is greatly improved by passing the material through a sausage grinder, which breaks it up into a mass of brown granules. In this condition it looks well when put up in glass jars or fiber-ware packages. The only remaining objection to it is an offensive alkaline odor. In attempts to eliminate this disagreeable quality I have treated both the raw and cooked flesh with salt, with vinegar, and with hydrochloric acid in various proportions and for various periods of time preliminary to the drying, but without success. The purpose of using the acid, which was in very dilute solutions, was to neutralize the alkaline compounds as fast as they were formed. Dried mussels which had been soaked in a 0.2 per cent solution of hydrochloric acid for two hours before desiccation were rendered remarkably free from any bad odor. After being bottled up for a few weeks, however, they acquired the smell so characteristic of the dried material.

In spite of this offensive property the dried mussel can be used in preparing a very palatable soup or chowder. A better smelling variety will have to be produced, however, before there can be a possibility of attaching commercial importance to it.

The chief trouble with this process is that the drying is accomplished at a high temperature, where chemical changes within the food material are accelerated, causing the production in large quantities of undesirable substances. This difficulty is removed by means of an improved method of desiccation devised by Shackell (1909). Briefly, this consists in freezing the flesh, and drying it, while still in the frozen condition, in a vacuum. At this low temperature chemical changes practically cease and with the extraction of moisture a very stable substance is secured which will withstand all ordinary temperatures. Mussel flesh treated by this method shows remarkable properties. It retains the color and form of the fresh material; it is light and porous and can be easily crushed between the fingers. In air-tight bottles it may be preserved indefinitely.

A sample of mussel thus prepared, after having been kept a month, was placed in a small dish of water. The dried material rapidly absorbed moisture and at the same time the natural juices dissolved out into the water, giving it the characteristic opalescent color of fresh mussel liquor. The odor was that of perfectly fresh mussels, and when made into soup the aroma and flavor were those of cooked fresh material. This method of preservation is ideal but for one reason—the high cost forbids its use commercially. The inventor of the method is working to overcome this disadvantage.

COLD STORAGE.

The mussel is not well adapted to the method of preservation by means of cold storage. The writer wishes to make this statement with reserve, however, since his experiments in this respect have been very limited. Attempts to keep mussels fresh in an ice chest for more than twenty-four hours met with failure. They appeared to live no longer in the cold than in the open air. Decay did not seem to be retarded by the lower temperature of the ice box. This fact was a matter of complaint made by a New York dealer who wished to develop a market for mussels inland. I was informed that it would be possible to develop quite a trade in mussels if a method for preserving them in the fresh or living condition could be devised. At present I can only suggest a probable solution of the problem; that is to reduce them to a freezing temperature and ship them in a double walled carrier having a vacuum between the walls. The vacuum being a nonconductor of heat insures the continued low temperature of the mussels and does away with the surplus weight of ice usually employed in cold-storage transportation. The mussels preserved in this manner would have to be used almost immediately after removal from the carrier. Further mention of this method of preservation will be found in my conclusions and recommendations.

RECIPES FOR COOKING SEA MUSSELS.

CREAMED MUSSELS.

Thoroughly wash the mussels and place them in boiling water until the shells begin to open. Pour off the water quickly, take out the "beard" or byssus, and remove the meats from the shell, preserving the liquor in a separate dish. For each cupful of chopped meats make one cupful of cream sauce, which is prepared by melting in a saucepan one tablespoonful of butter and stirring with it one tablespoonful of flour; cook, being careful not to brown it; then stir in slowly one-half cupful of mussel liquor and one-half cupful of milk or cream and season with pepper and salt to taste. Continue to cook until it is thick and creamy, stirring all the time; add the mussels just before serving. Pour the mixture over small pieces of toast laid on the bottom of the dish.

FRIED MUSSELS.

After thoroughly cleaning the outsides of the mussels boil them until the shells begin to open. Take out the "beard" and remove the meats from the shell. Season with salt and pepper, then roll in cracker or bread crumbs, dip in egg beaten up in milk, and roll again in the crumbs; fry quickly in hot fat; drain on paper as fast as taken up. Serve hot, garnished with slices of lemon. Have them as free from grease as possible.

MUSSEL CAKES.

Clean and scald the mussels as directed above, beard, and remove the meats. To one pint of chopped mussel meats add two eggs, one-half cupful of milk, two teaspoonfuls of baking powder, and a pinch of salt. Stir in enough flour to make the mixture a little thicker than pancake batter and fry.

MUSSEL CHOWDER.

Clean and scald the mussels as directed above, take out the beard, and remove the meats, preserving the natural liquor in a separate dish. To a quart of the meats take a quarter pound of salt pork; cut it into small squares and fry to a brown in the bottom of the kettle. At the same time add three or four sliced onions and cook until the pork is well tried out; then add the mussel liquor, mixed with an equal quantity of water, and when it comes to a boil add six finely chopped or sliced potatoes and boil in a closely covered dish until the potatoes are done; then add the mussels with one quart of boiling milk, season with pepper and salt to taste, and serve.

MUSSEL CROQUETTES.

Clean and scald the mussels as directed above, beard, and remove the meats from the shell. Chop up one pint of meats, moisten with a thick cream sauce, add one teaspoonful of chopped parsley and bread or cracker crumbs sufficient to make the mixture firm enough to shape, season with salt and pepper. Let the mixture get cold, then shape into croquettes and fry in hot fat, in a frying basket if available; drain and serve on a hot napkin.

MUSSEL FRITTERS.

Two eggs, one tablespoonful of oil, one cupful of flour, one-half cupful of mussel liquor, pinch of pepper and salt, tablespoonful of lemon or vinegar, one cupful of chopped mussel. Have the mixture quite thick and drop from a tablespoon into hot fat and fry until an amber color.

MUSSEL PATTIES.

Cut one quart of scalded mussels into small pieces and stir into one cup of rich drawn butter based on milk, season to taste, cook five minutes, fill the patty cases, heat two minutes, and serve

MUSSEL SOUP.

Clean and scald the mussels as directed above, beard, and preserve the meats and liquor in separate dishes. To one pint of the liquor add an equal quantity of water; season with pepper, mace, and salt, and boil five minutes. Then put in the mussels, either whole or minced, and boil for five minutes with the vessel closely covered. Then add a pint of milk thickened with a little flour and butter or fine cracker crumbs. The addition of a little chopped celery and onion improves the flavor.

ROASTED MUSSELS.

Wash the shells thoroughly with a brush and cold water. Place them on a pan and bake in a hot oven until the shell opens. Remove the upper shell carefully, so as not to lose the liquor, and arrange them on plates. On each mussel place a piece of butter and a little pepper and salt. Do not roast too long.

STEAMED MUSSELS.

To a gallon of thoroughly washed mussels, add one cup of water and boil in a closely covered vessel for ten minutes or until the mussels on top are well opened. Then pour off the water and place the mussels in a large dish on the center of the table. Serve to each person some melted butter to which may be added vinegar and pepper to taste. The mussels may be removed from the shell, bearded, and, held by the foot, dipped into the butter and eaten.

The French people are noted for their excellent preparations of mussels for the table. The characteristic feature of nearly all their methods is to serve them on the half shell. From Audot's "La Cuisinière de la Ville et de la Campagne" I have taken the following recipes:

MUSSELS (ENTRÉES).

Choose mussels which are fresh, heavy, and of medium size, scrape and wash them through several waters. (In order that one may have no fear of them, it is necessary to cleanse them for five or six hours in water which is renewed several times. Not only are they able to reject the impurities within them, but they gain in quality. It is necessary to avoid using them from April to September, during which time they are apt to be unhealthy.)

A la marinère.—Having cleaned the mussels well, place them in a saucepan with some white wine, a glass to 4 quarts, or else a spoonful of vinegar, some slices of carrots, onion, and parsley chopped fine, thyme, clove of garlic, a little salt and pepper, 2 cloves, and a piece of butter the size of an egg. Place the saucepan on a good fire, keeping it covered from the first to make the shells open. Stew continuously until the shells have opened, when the mussels are done. From each remove one of the shells and take out the little crabs which are found in them, but which are not injurious in any way; they are found present principally during the months of the year which do not contain the letter "r." When the mussels have thus been opened, stew them a while (stirring or shaking to prevent them from sticking to the saucepan) and then turn them into a large, deep dish with a quart of their dressing strained clear. The remainder of this dressing makes a very agreeable onion soup.

A la poulette.—Take up quickly some of the prepared mussels (steamed and prepared on the half shell), as they are called, and make a sauce with a piece of butter, a pinch of flour, a little of their liquor, and the yolks of eggs, if these are desired. Turn this upon the mussels and serve.

A la béchamel.—Pour over the mussels a béchamel sauce in place of the sauce poulette.

BÉCHAMEL SAUCE.

Melt a piece of butter (about 1 ounce) and mix well with it a spoonful of flour and some salt and white pepper. Moisten it with a glass of milk, a little at a time with constant stirring; let it boil, being continually stirred. At the same time warm over that which you wish to serve with the sauce. To make it more elaborate, place in a saucepan some butter, slices of onion, a carrot, a bunch of parsley, some mushrooms, and place it on a fire. Moisten with some boiling milk, adding a little at a time with constant stirring; add some salt, white pepper, and nutmeg, and stir until it boils. Allow it to cook very slowly for three-quarters of an hour, then strain it through a colander. In a saucepan make a light-brown butter sauce with 3 spoonfuls of flour and turn into it the milk broth; let it boil three minutes.

Attention should be called to the fact that Audot's precaution to avoid eating mussels between the months of April and September does not apply to all parts of the world. On our northern Atlantic coast the months between April and September are the very months when the mussels are best for eating purposes, while during the fall and early winter they are unfit for use. The explanation of this is that the mussels of France breed in the early spring while these on our coast breed in the late summer and fall. After spawning the mussels become sickly and great numbers of them die. A more general way to state the precaution is: Avoid eating mussels from a given locality during the four months following their spawning. At the end of this period they again become fat and healthy.

CULTIVATION OF MUSSELS.

In Europe, where there is considerable demand for mussels as food and bait, it long ago became necessary to cultivate them artificially on a large scale. Two methods were devised. One may be termed the buchot system or French method, and the other the bed system or British method. The buchot system is apparently much the older and its history, although published in many French and English periodicals, is so interesting that it ought to be recorded again briefly at this point.

Strange as it may seem, this French system of culture was invented by an Irishman named Walton who was the sole survivor from a shipwreck in the Bay of Aiguillon near the village of Esnandes some seven or eight centuries ago. Authors disagree as to the exact date. Quatrefages (1854) states that it was in the year 1035, Bertram (1865) says 1135, while Coste (1883) puts it at the close of the year (1235). Walton was kindly received by the French fishermen, with whom he decided to make his home, although the prospects of making a good living were not very bright.

Up to the time of Walton's arrival the inhabitants of the coast had been unable to get much sustenance from the sea, but the newcomer was ingenious and was not long in originating a means for earning a livelihood from this source. His first step was to explore an immense lake of mud which was in the locality and there observing that large numbers of land and sea birds were in the habit of skimming over the water at twilight, he determined to catch them as an object of trade. For this purpose he devised a large net, the "alluret," which was between 330 and 430 yards long and 10 feet in height, fastened in a vertical position to stakes driven into the mud to a depth of 3 or 4 feet. Birds flying into its meshes were entangled and held securely. Shortly after beginning his bird-catching business, Walton discovered that young mussels in great numbers were collecting on the submerged stakes of his net. He also observed that mussels suspended for some distance over the mud grew to a larger size and were better flavored than those upon the mud. He experimented by putting down many more stakes, which in turn became covered with growing colonies of mussels. Continuing his experiments he was soon convinced that the young of native mussels could be easily gathered and profitably raised in artificial reservoirs.

The buchot system of mussel culture that was finally established by Walton is still followed and has proved a lasting reward and blessing to that locality, where at the present time buchots extend for miles along the coast and give support to several thousand inhabitants. In 1905 the village of Esnandes alone marketed 215,253 bushels of mussels, valued at \$112,433. The total number of mussels cultivated on the French coast in 1905 is estimated at 425,492 bushels, valued at \$222,439.

Walton's buchots, or wooden inclosures for the artificial rearing of mussels, were made V shaped, with the apex pointing out to the sea, the purpose of this arrangement being to protect the structure from the destroying action of the wind, waves, and ice. Each wing of the V consisted of a row of stakes placed about 2 feet apart and interlaced with a meshwork of flexible willow or chestnut branches some 12 to 18 feet long and

2 inches in diameter at the larger end. The stakes were trunks of trees, $\frac{1}{2}$ to 1 foot in diameter and from 12 to 15 feet long, driven into the mud for about one-half their length. The meshwork covered the stakes to within 8 inches of the bottom, the space being left to allow free circulation of water, so as to prevent the deposition of mud at the base of the stakes. Each horizontal line of branches was tightly woven to the stakes to prevent slipping up or down. They were arranged about 20 or more inches apart, because, if brought together closer than that, they were apt to collect mud and cause deposits that would interfere with navigation and perhaps seriously injure the apparatus itself.

The length of wings to a buchot at any particular place depended, as now, on the nature of the bottom on which they were constructed. At present they occupy about one-fourth of the distance between the extreme limits reached by the water at high and low tides. In the Bay of Aiguillon they are now constructed about 250 yards long, and according to Herdman (1894), who has made an extensive study of this region, are no longer arranged in the V form, but in parallel rows about 30 yards apart at right angles to the shore. The buchots are practically made up of two divisions, one for collecting spat and the other for the growth and fattening of the mussels.

Five series of buchots may be included in these two divisions: (1) Buchots d'aval, (2) buchots batisse, (3) buchots du bas, (4) buchots batards, and (5) buchots d'amont.

The buchots d'aval are out in the deep water, sometimes 3 miles from high-water mark, and are exposed only at the lowest tides. They are composed merely of solitary stakes placed about 1 foot apart. They serve to catch the spat and constitute a most favorable place for the early growth of the mussels, since it is necessary for the young to be protected from long exposure to the sunlight or extreme cold. The spat collects on these stakes during February and March. By July the young mussels have attained the size of a haricot bean.

At this time the seed mussels are scraped off the piles by means of hooks fastened in a handle, are collected in baskets, and transferred to the next zone of weirs, the buchots batisse, toward shore and ordinarily uncovered after high tides. The parcels of young mussels are fastened by means of old netting to the branches, where, before the netting decays away, they become firmly attached by their byssal threads. When the mussels have grown so large as to be crowded on the wickerwork, they are thinned out by removing the larger ones to the next higher buchots, and so on from one section to the other, each time transferring the mussels nearer the shore. The mussels are attached by the same operation already described, but are not wrapped so carefully since their size is such as to enable them to be more securely fastened without help of the netting. The work of transferring from one buchot to another goes on day and night whenever low tide permits it.

After about one year's treatment under these conditions the mussels attain marketable size, which is between $1\frac{3}{4}$ and 2 inches in length. Before being offered for sale, those that have reached the desired size are transplanted to the highest row of buchots, the buchots d'amont. In this location, although left dry twice each day, they thrive well and can be easily handled when desired for market. The mussels on these upper rows become inured to exposure and consequently keep longer and fresher than those from

the lower rows. The poorest of cultivated mussels are considered superior to the best mussels grown under natural conditions.

To traverse the soft mud from one buhot to the other Walton devised the "acon," a characteristic mudboat still used by the bucholeurs. Herdman (1894) describes it as follows:

The "acon" is composed of a plank forming the bottom and bent up in front to make a flat prow. The sides and stern are each made of one piece of wood, sometimes the sides are of two planks each. The size is 9 or 10 feet in length, from 2 feet to 2 feet 6 inches wide, and about 1 foot 6 inches deep. There is a shelf at the stern, a narrow thwart close to the bow, and a small wooden stool in the middle of the floor; these with a wooden paddle and a short pole complete the equipment. The boatman in using the "acon" faces the bow, grasps the sides about the middle firmly with both hands, rests his left knee on the floor of the boat, and putting his right leg (encased in a long sea boot) over the side, he plunges it into the mud and pushes it onward. He is able to propel it at a great rate over the soft mud, and when he gets to a channel of water where the "acon" floats he works with paddle or pole until he again reaches mud and is able to use his foot.

The British method of mussel culture, briefly, is to collect young mussels from salt water and transfer them to artificial beds in favorable localities. These are generally situated in estuaries where the water is brackish and where they are not exposed at low tide, both of which conditions are supposed by many to favor growth and fattening. Others believe that the presence of fresh water is injurious to the young shellfish and of no advantage to the full-grown individuals. To support their views they point to the large beds of healthy, uniform-sized individuals in regions far removed from the influence of fresh water. Harding (1883) believes that the spat will not mature in anything but pure sea water, but that for fattening full-grown mussels brackish water of the density 1.014 is most suitable. It has been estimated that the average yearly yield of an acre of such mussel beds is 108 tons, worth at least \$262.

Careful cultivators observe several rules in planting mussels. They may be planted on almost any natural bottom, but rich estuarine flats where there is plenty of sand and gravel covered with mud rich in diatoms, infusoria, and spores of algæ is considered the ideal situation. They are placed in positions where they are not exposed to dangers from floods, gales, shifting sands, or frost. The beds are so placed that they will not be uncovered long at low tide nor where silt is likely to deposit upon them. Should this evil be discovered the bed is immediately transplanted to a better situation. In planting the beds care is taken not to place the individuals so close together that one will come to lie on another and thus cause a too crowded condition.

For collecting the mussels a rake or dredge is used, the former instrument being considered better than the latter for the reason that it does not crush the shells nor cause sand to shift over the bed. In size it has a breadth of about 18 inches, with the teeth 1 inch apart. It is fixed to a pole 20 to 25 feet long and has a wire net bag behind it for holding the catch. The large and small mussels are separated by means of a riddle, which is an instrument having a 1-inch iron mesh. The bunches of various size mussels are first separated by hand and then sifted, or riddled. The large and small mussels thus divided are then placed in separate beds or the large ones utilized for bait.

Other methods of mytilculture are followed in certain localities. Goode (1887), describing some of the European methods, says:

In the North Sea these [spat collectors] consist of large numbers of trees, from which the smaller branches have been cut, and which are planted in the bottom of the sea at such a distance from the shore that their upper portion is partially laid bare at low water. After four or five years they are raised, stripped, and replaced by others. In the Bay of Kiel, Germany, alone about 1,000 of these trees are annually planted and about 1,000 tons of mussels are brought on the market. Bad seasons occur, however, both with respect to quality and quantity, owing to various causes. In the Adriatic the mussels are raised on ropes extended between poles rammed into the ground. The ropes are raised and stripped once in eighteen months.

The question now arises, Which is the better method for artificially propagating mussels on our coast? This depends on two factors; (1) the quality of mussels produced, and (2) the actual expense of propagation as compared with the financial return. Though I unfortunately can not answer this question now, I can throw a little light on it from the experience of others. In France, where labor is cheap, the buchot system is most profitable, while in England, where the cost of labor is much higher and where favorable localities for buchot culture are few, the bed system has to be employed. That the buchot method of culture is not practicable for the Scottish coast is very evident from the extensive report of Fullarton (1891), whose conclusion I quote:

The buchot experiment, therefore, does not promise to yield in Scotland the same good results as in France. This is due to the character of the mud along our shore, to the climatal conditions of our Scottish waters, and the influence of these on animal life. But the financial aspect of the question, as shown above, is absolutely fatal to the system. I can not conceive what modifications of the buchot system would be likely to yield results which would benefit the fishermen of Scotland, nor mitigate in any important degree the mussel famine; while the bed system only requires to be developed in suitable localities in order that fishermen may obtain an ample supply of bait at a cheap rate and on sound financial principles.

Calderwood (1895) states that the buchot system of culture has been tried on a small scale at five different places in Scotland, and in every case was a failure. At Little Ferry the mussels were washed from the structures by gales; at Tain one buchot was covered with shifting sand, while another erected in an unfortunate position yielded little return. At Inverness the cost of handling the mussels was found prohibitive and at Montrose the system was found unsatisfactory because the mussels fell from the laths, which were used instead of branches. Where the cost of building material and labor are high, the buchot system will be found unprofitable.

Herdman (1894) believes that mussels grown on buchots are no better than those grown on beds, and thinks the buchot system is necessary only in localities where the mud is soft and so constantly depositing as to prohibit a bed of mussels from being established. Lebour (1907), describing the mussel beds of Northumberland, believes that the bed system is the only suitable method of cultivation on the coast and that the buchot system is not a practical one to apply even at Budle Bay and Holy Island, which regions are best adapted for their use.

In view of the facts just stated, and especially in consideration of the high cost of building material and of labor in the United States, the prospects are very poor for

successfully cultivating mussels by the buchot method on our shores. No serious objections having yet been found to the bed system, we are left to utilize that method with better hopes of success, unless in the meantime a better method is devised.

POISONOUS MUSSELS.

Mussels, like oysters, clams, and other shellfish, are subject to contamination from parasites, bacteria, and the ptomaines generated by these, which render them a dangerous food unless selected with proper care. Cases of serious illness from eating poisonous mussels are known and a number of persons have died from the effects. The same is true of oysters and clams, and inasmuch as the symptoms in all the cases are similar, there is nothing here to indicate that the mussels are not just as safe a food as the other shellfish when gathered with the same precautions. If they are collected from pure water and eaten in a fresh condition, they are a wholesome food. It sometimes happens, however, that the individual is peculiarly susceptible to poisoning from shellfish, and such persons I would advise to abstain from eating them.

The most common cases of poisoning from mussels and other shellfish are due to ptomaines, which are poisonous substances resulting from the action of micro-organisms upon the animal tissues. Their formation usually, although not always, accompanies putrefaction and they are said to be most abundant in its early stages. It is therefore safest to prepare for the table only shellfish that are in a healthy, living condition. Dead mussels should never be purchased. Good specimens are free from any stale odor and do not remain with the shells open after being slightly irritated. They defy all efforts to open their shells until the muscle which holds them shut is cut.

Dangerous intestinal troubles, followed by eruptions on the skin, have been known to result from eating apparently fresh mussels. Various explanations have been offered to account for these effects. Goode (1887) states that the Alaskan Indians, recognizing this fact, eliminated it by removing the byssus or beard whenever it had a greenish color, which was a sign that the animal had been feeding upon poisonous material. Better evidence, however, shows that these evil effects come rather from mussels which grow in impure waters, and that the injurious qualities lie in the liver rather than the byssus.

In the year 1885, at Wilhelmshaven, Germany, a large number of people were taken seriously ill after eating the sea mussel, *Mytilus edulis*, gathered from the harbor of that place. Several died from the effects. The symptoms of the poisoning were of three kinds, (1) a swelling in the head and abdomen, with the appearance of red spots on the body; (2) diarrhea, cramps, and prostration; and (3) paralysis.

A careful study of the conditions revealed that the water from which the mussels were taken was stagnant because of the inclosing breakwater, which cut off the effects of the tides. Although no sewage emptied into the harbor and ships were forbidden from dumping refuse into the water, the stagnated water was so impure that its effect upon animal life was highly injurious. Fishes that found their way in through the sluice gates soon became so sluggish that they could easily be caught by hand. Eels were

observed to lose almost all their vitality during the summer. Mussels from these waters, when cooked and fed to rabbits, acted as a most virulent poison, killing them in from two to ten minutes. If the mussels were transferred to places where currents of pure water could flow over them they lost all their poisonous properties; and, on the other hand, if harmless mussels were transferred from outside waters to the harbor they acquired poisonous qualities in less than two weeks.

Virchow (1886) and Wolff (1886) affirm that the poison was not the result of any decomposition and that the mussels had no external signs of disease. Wolff's experiments indicate that the liver is the sole source of the poison. Inoculations from that organ into rabbits and guinea pigs were fatal in every case in from two to twenty minutes, while inoculations from other parts were without effect. He believes that the poison originated in the liver and was not due to the absorption of copper salts, as popularly believed.

Another record of a serious case of poisoning from the eating of mussels by a party of Alaskan Indians is briefly mentioned by Dall (1870) and Petroff (1884). In response to a request for further details of the incident Doctor Dall wrote me the following story, which is amplified somewhat from notes gleaned from the references just cited: The Sitkan natives, being able to get better prices from the Hudson Bay Company, refused to trade with Baranoff, the Russian director of Alaska. Baranoff therefore resorted to importing, on a sailing vessel from Unalaska and Kodiak, a large number of Aleut hunters with their skin canoes, to take sea otter in the islands of the Sitkan Archipelago. In the year 1799 a party of about 200 camped on the shores of the strait separating Baranoff from Chichagof Island, where the tides are great and at low water expose great numbers of mussels. Being accustomed to eat them at home, the Aleuts gathered a quantity of mussels and feasted upon them. In a few hours they were taken violently ill, and 150 died within a day or two. This incident gave rise to the name Peril (in Russian, Pogibshi) Strait, which name it bears to this day. Mussel poisoning in this region is known to have occurred on other occasions and is supposed to be due to the ptomaines developed in the liquor of the mussels exposed to the sun. Doctor Dall was informed by the Aleuts that specimens not actually out of water were always safe.

In Audot's "*La Cuisinière de la Ville et de la Campagne*," page 677, a paragraph is devoted to the symptoms and treatment of mussel poisoning. A free translation of it is as follows:

The true cause of the poisoning produced by mussels is not yet known, but it is a mistake to attribute it to the presence of the small crabs which are found in their shells. The opinion more generally accepted to-day is that the mussels, by attaching themselves to the bottoms of ships sheathed with copper, absorb a certain quantity of verdigris, which produces the poison causing indigestion. Whether this is so or not, the use of these mollusks sometimes leads to symptoms of very serious poisoning, of which the more common are: A sharp pain in the region of the stomach, violent cramps, severe contractions of the chest, an alternating quick and slow pulse, a redness and swelling of the face, an eruption of little red spots upon the skin, cold sweats, and oftentimes convulsive movements and delirium.

When these symptoms manifest themselves it is necessary to combat them promptly by employing an emetic (2 grains of emetic in a glass of tepid water taken several times at six-minute intervals), and

when a sufficiently long time has elapsed since the ingestion of the mussels, follow the emetic with a purgative such as 60 grams of castor oil in a cup of light bouillon. If the symptoms continue in spite of these means, give the patient some mucilaginous drink and call a doctor.

The foregoing account would probably frighten the average person from ever attempting to use mussels as an article of food. Careful inspection, however, will reveal the fact that the mussels which have caused serious illness came either from impure waters or had been exposed to the heat of the sun so long that ptomaines had time to form in the liquor within their shells. Mussels taken from pure water which has free circulation have never been known to produce injurious effects when eaten. A New York dealer who has been selling mussels for years has never known of a case of poisoning from them. Nevertheless, too much emphasis can not be given to the fact that care must be exercised in choosing proper localities for the cultivation and collection of mussels for market. They must be sold to the consumer in a perfectly fresh condition or serious results will be likely to follow.

SUMMARY, CONCLUSIONS, AND RECOMMENDATIONS.

1. The sea mussel, *Mytilus edulis* Linnæus, is not utilized as a food to any extent in the United States outside of the vicinity of New York City.

2. As a food material it is superior to many articles which are commonly eaten. Scores of persons have pronounced it to be equal in flavor, or even superior, to the oyster; it is easily digested, has high nutritive value, and is exceedingly abundant and general in its range. Especially for persons living on the coast it is an excellent cheap food.

3. Along most of our eastern coast the mussel is in season for food purposes when the oyster is out of season.

4. The mussel is well adapted to preservation. When canned or pickled it will retain its natural flavor for months.

5. The mussel breeds at a prolific rate, it develops rapidly, requires less special conditions for growth than the oyster, and may therefore be easily cultivated.

6. The only difficulty in the marketing of mussels for food purposes is that they spoil quickly after being removed from the water. It is necessary to use them within twenty-four hours after they are collected or ptomaine poisoning may result. To insure one's self against illness from eating them, the mussels must be taken from water that is pure and subject to the constant circulation of tidal currents.

7. Other important ways for utilizing mussels are as bait for the fisheries and as fertilizer for soil on which onions and carrots are to be raised.

In view of these facts it is clear that the mussel beds of our eastern and western coasts constitute a valuable food resource of the nation which so far has not been developed. The natural beds alone are capable of supplying wholesome food to thousands of persons at the expense of a little trouble to collect the mussels and to hundreds of thousands more people, through the markets, at a moderate price. It is possible to develop an industry in the marketing of mussels which may surpass even that of the oyster and at the same time have no injurious effect upon the oyster trade. The success

with which mussels may be canned and pickled promises a good future for such a branch of the business.

The author recommends (1) that the facts set forth in this paper be made known to the packers of marine food products and widely advertised among the fishing population of our northern Atlantic and Pacific coasts; (2) that investigations be instituted to determine a method for preserving mussels in a fresh living condition long enough to permit their being readily shipped and sold at the inland markets, and the further investigations on methods for preserving mussels by canning, pickling, etc., which will make it possible to transport to long distances without being broken or otherwise injured should be continued; and (3) that a detailed study of the life history of the mussel be made as of the oyster. The solution of these problems, it is believed, will help to develop a new and profitable branch of fisheries industry.

LITERATURE.

- ALLEN, E. J., and TODD, R. A.
1902. The fauna of the Exe estuary. *Journal Marine Biological Association*, vol. 6, no. 3, p. 295-343.
- ANDERSSON, JOAKIM.
1880. The fishery exhibition in Philadelphia in 1876. Report U. S. Commissioner of Fish and Fisheries for 1878, p. 47-71.
- ATWATER, W. O.
1891. The chemical composition and nutritive values of food fishes and aquatic invertebrates. Report U. S. Commissioner of Fish and Fisheries for 1888, p. 679-868.
- ATWATER, W. O., and BRYANT, A. P.
1906. The chemical composition of American food materials. (Corrected Apr. 14, 1906.) *Bulletin* No. 28, U. S. Dept. of Agriculture.
- BERTRAM, J. E.
1869. *The harvest of the sea*, 2d ed., p. 40-417. London.
- CALKINS, GARY N.
1902. Marine Protozoa from Woods Hole, Mass. *Bulletin U. S. Fish Commission*, vol. XXI, 1901, p. 415-468.
- COSTE, M.
1883. Report on the oyster and mussel industries of France and Italy. Report U. S. Fish Commission for 1880, p. 825-883.
- DALL, WILLIAM H.
1870. *Alaska and its resources*. Boston.
- FRAICHE, FELIX.
1883. A practical guide to oyster culture, and the methods of rearing and multiplying edible marine animals. Pt. v.—Cultivation of mussels. Report U. S. Commissioner of Fish and Fisheries for 1880, p. 810-818.
- FULLARTON, J. H.
1891. On buchot mussel culture and the buchot experiment at St. Andrews. Ninth Annual Report of Fishery Board for Scotland, pt. III, for year 1890, p. 212-221. Edinburgh.
- FULLARTON, J. H., and SCOTT, T.
1889. Mussel farming at Montrose. Seventh Annual Report of Fishery Board for Scotland, p. 327-341, pl. VII.
- GANONG, W. F.
1889. The economic molluska of Acadia. Reprinted from *Bulletin* no. VIII. Natural History Society of New Brunswick. St. John, N. B.

GOODE, G. BROWN.

1884. The fisheries and fishery industries of the United States. Sec. I, Natural history of aquatic animals, 709 p.—U. S. Fish Commission, Washington.

1887. The fisheries and fishery industries of the United States. Sec. v, vol. II, History and methods, Mussel fishery, p. 615-622. U. S. Fish Commission, Washington.

GOULD, A. A.

1870. Report on the invertebrata of Massachusetts, 2d ed., edited by W. G. Binney. VIII+524 p., 12 pl. Boston.

HARDING, CHARLES W.

1883. The utilization of localities in Norfolk and Suffolk suitable for the cultivation of mussels and other shellfish. Bulletin U. S. Fish Commission, vol. II, 1882, p. 83-88.

HERDMAN, W. A.

1894. Report upon the methods of oyster and mussel culture in use on the west coast of France. Report for 1893 of the Lancashire Sea-Fisheries Laboratory, p. 41-80, pl. I-III.

KING, WILLIAM.

1891. Mussels and mussel culture. Northumberland Sea Fisheries Committee, p. 1-8. Newcastle-on-Tyne.

LEBOUR, MARIE V.

1907. The mussel beds of Northumberland Sea Fisheries Committee. Report on the Scientific Investigations for the year 1906, p. 28-46. Newcastle-on-Tyne.

M'INTOSH, W. C.

1885. Notes from the St. Andrews Marine Laboratory (under the Fishery Board for Scotland). I. On the British species of *Cyanea* and the reproduction of *Mytilus edulis* Linn. Annals and Magazine of Natural History, vol. XV, p. 148-152.

MILNER, R. D.

1903. The cost of food as related to its nutritive value. Reprint from Yearbook of U. S. Dept of Agriculture for 1902, p. 387-406.

MOORE, H. F.

1907. Survey of oyster bottoms in Matagorda Bay, Texas. Bureau of Fisheries Document No. 610. 86 p., 13 pl., 1 chart.

PECK, J. I.

1894. On the food of the menhaden. Bulletin U. S. Fish Commission, vol. XIII, 1893, p. 113-126, pl. 1-8.

1896. The sources of marine food. Ibid., vol. XV, 1895, p. 351-368, pl. 64-71.

PETROFF, IVAN.

1884. Report on the population, industries, and resources of Alaska. House of Representatives, Miscellaneous Document for 2d sess. of 47th Congress, 1882-83, vol. XIII, no. 42, pt. 8.

QUATREFAGES, A. DE.

1854. Souvenirs d'un Naturaliste. Paris.

SCOTT, A.

1901. Note on the spawning of the mussel. Ninth Report of the Lancashire Sea Fisheries Laboratory for 1900, p. 36-39. Liverpool.

SHACKELL, L. F.

1909. An improved method of desiccation with some applications to biological problems. Journal of Physiology, vol. XXIV, no. III, p. 325-340.

SIMMONDS, P. L.

1879. Commercial products of the sea. VIII+484 p., illus. New York.

VERRILL, A. E., and SMITH, S. I.

1873. Report upon the invertebrate animals of Vineyard Sound and the adjacent waters, with an account of the physical characters of the region. Report of U. S. Fish Commission for 1871-72*, p. 295-778, pl. I-XXXVIII.

- VIRCHOW, RUD., and LOHMEYER, CARL; SCHULZE, FR. EILK., and MARTENS, E. v.
1885. Beiträge zur Kenntnis der giftigen Miesmuscheln. Archiv für pathologische Anatomie und Physiologie und für klinische Medicin, bd. 104, p. 161-180.
- WOLFF, MAX.
1885. Die Localisation des Giftes in den Miesmuscheln. Archiv für pathologische Anatomie und Physiologie und für klinische Medicin, bd. 103, p. 187-203.
1885. Die Ausdehnung des Gebietes der giftigen Miesmuscheln und der sonstigen Seethiere in Wilhelmshaven. Ibid., bd. 104, p. 180-202.
- WILLIAMSON, H. CHARLES.
1907. The spawning, growth, and movement of the mussel (*Mytilus edulis* Linn.), horse mussel (*Modiolus modiolus* Linn.), and the spoutfish (*Solen siliqua* Linn.). Twenty-fifth Annual Report of Fishery Board for Scotland for 1906, pt. III, p. 221-254, pl. XVI.
- WILSON, JOHN.
1887. On the development of the common mussel (*Mytilus edulis* Linn.). Fifth Annual Report of Fishery Board for Scotland for 1886, p. 247-256, pl. 12-14.
- WOLLE, FRANCIS.
1894. Diatomaceæ of North America. XIII+15+47 p., 112 pl. Bethlehem, Pa.

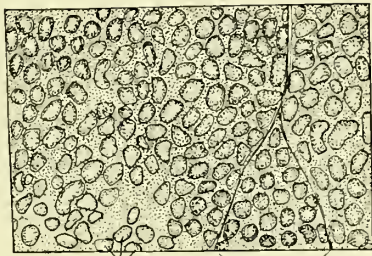

1

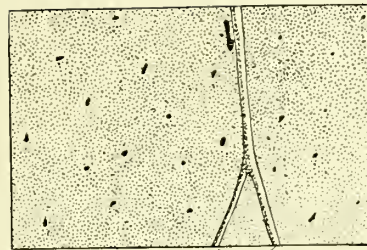

2

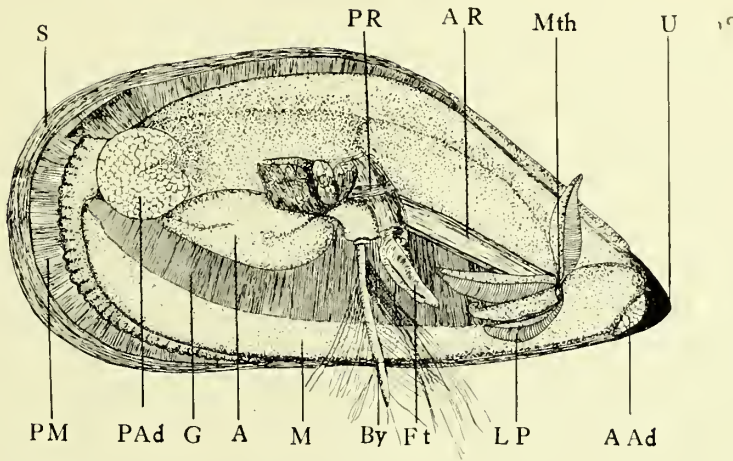

3

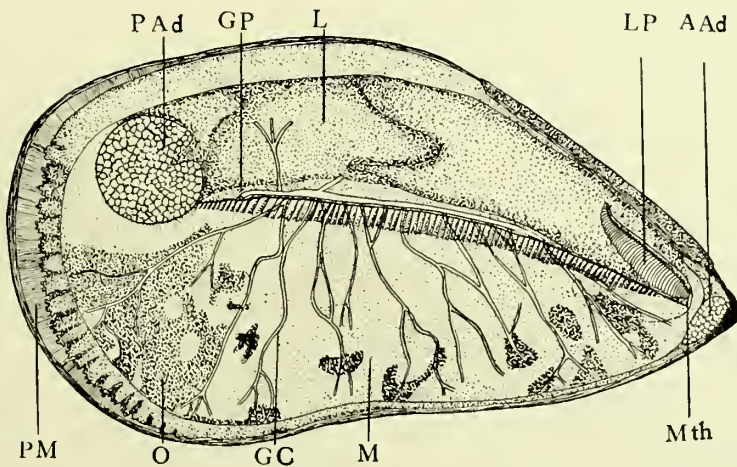

4

1.—Interior surface view of the mantle of a male mussel. $\times 10$.
 2.—Interior surface view of the mantle of a female mussel. $\times 10$.
 3.—Lateral view of a mussel with the shell and mantle of one side removed. Slightly enlarged.
 4.—Lateral view of a female mussel with the shell and mantle of one side and the foot, gills, and abdomen removed to show the main canals of the genital system. Slightly enlarged.
 Abbreviations: A, abdomen; AAAd, anterior adductor muscle; AR, anterior retractor muscle; By, byssus; F, follicle containing male genital products; Ft, foot; G, gills; GC, genital canals; GP, genital papilla; L, liver or digestive gland; LP, labial palps; M, mantle; Mth, mouth; O, ova remaining in the mantle after spawning (4 cc); PAd, posterior adductor muscle; PM, pallial muscles; PR, posterior retractor muscles; S, shell; U, umbo.

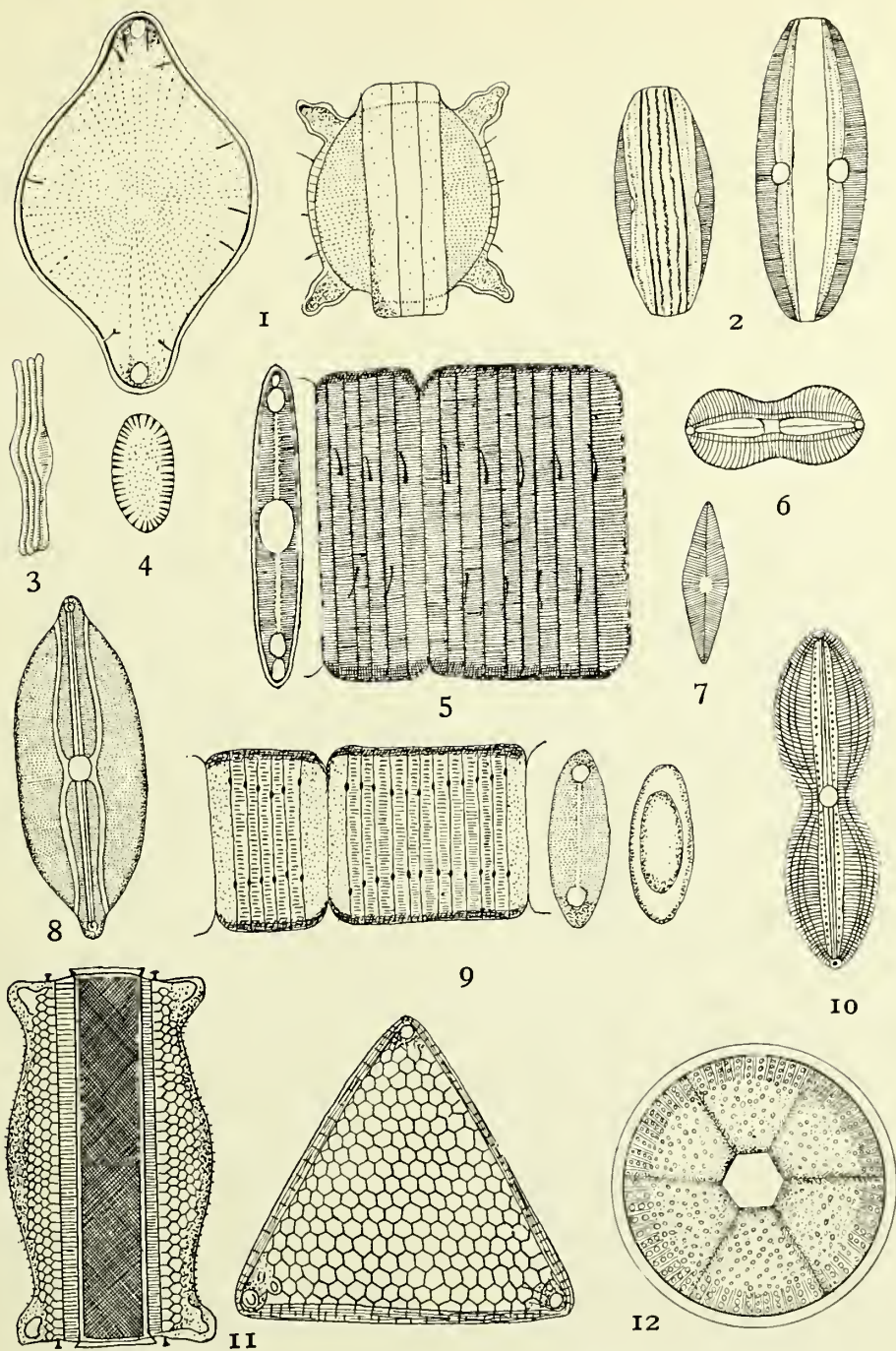

Organisms constituting the food of mussels. $\times 1,000$. Diatomaceæ (modified from Wolle).

1. *Biddulphia rhombus* (Ehrenberg) W. Smith.
2. *Amphora proteus* Gregory.
3. *Tabellaria fenestrata* Kützing.
4. *Suriella ovalis* var. *ovata* Brebisson.
5. *Rhabdonema adriaticum* Kützing.
6. *Navicula didyma* Ehrenberg.
7. *Navicula lanceolata* Kützing.
8. *Navicula lyra* Ehrenberg.
9. *Rhabdonema arenatum* Kützing.
10. *Navicula splendida* var. *puella* Ad. Schmitz.
11. *Biddulphia favus* (Ehrenberg) H. V. H.
12. *Actinopterychus undulatus* Ehrenberg.

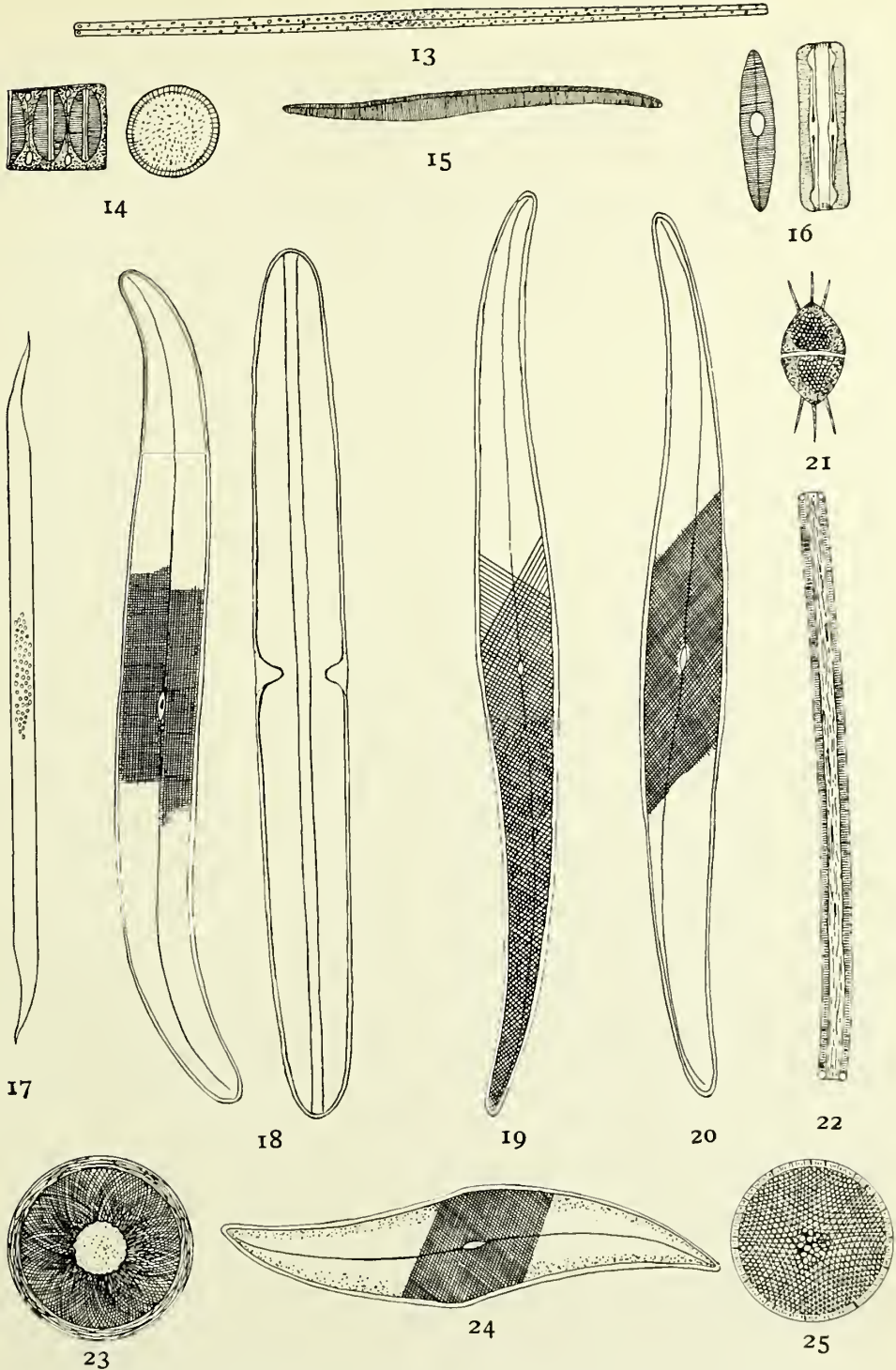

Organisms constituting the food of mussels. $\times 900$. Diatomaceæ (modified from Wolle).

13. *Nitzschia sigma* var. *sigmatella* Grunow. $\times 114$.
14. *Melosira sculpta* Kützing.
15. *Nitzschia sigma* Grunow.
16. *Grammatophora marina* Kützing.
17. *Rhizoselema setigera* Brighter. $\times 38$.
18. *Pleurosigma balticum* W. Smith.
19. *Pleurosigma elongatum* W. Smith.
20. *Pleurosigma decorum* W. Smith.
21. *Stephanopyxis appendiculata* Ehrenberg.
22. *Synedra gallionii* Ehrenberg.
23. *Hyalodiscus subtilis* Bailey.
24. *Pleurosigma angulatum* W. Smith.
25. *Coscinodiscus excentricus* Ehrenberg.

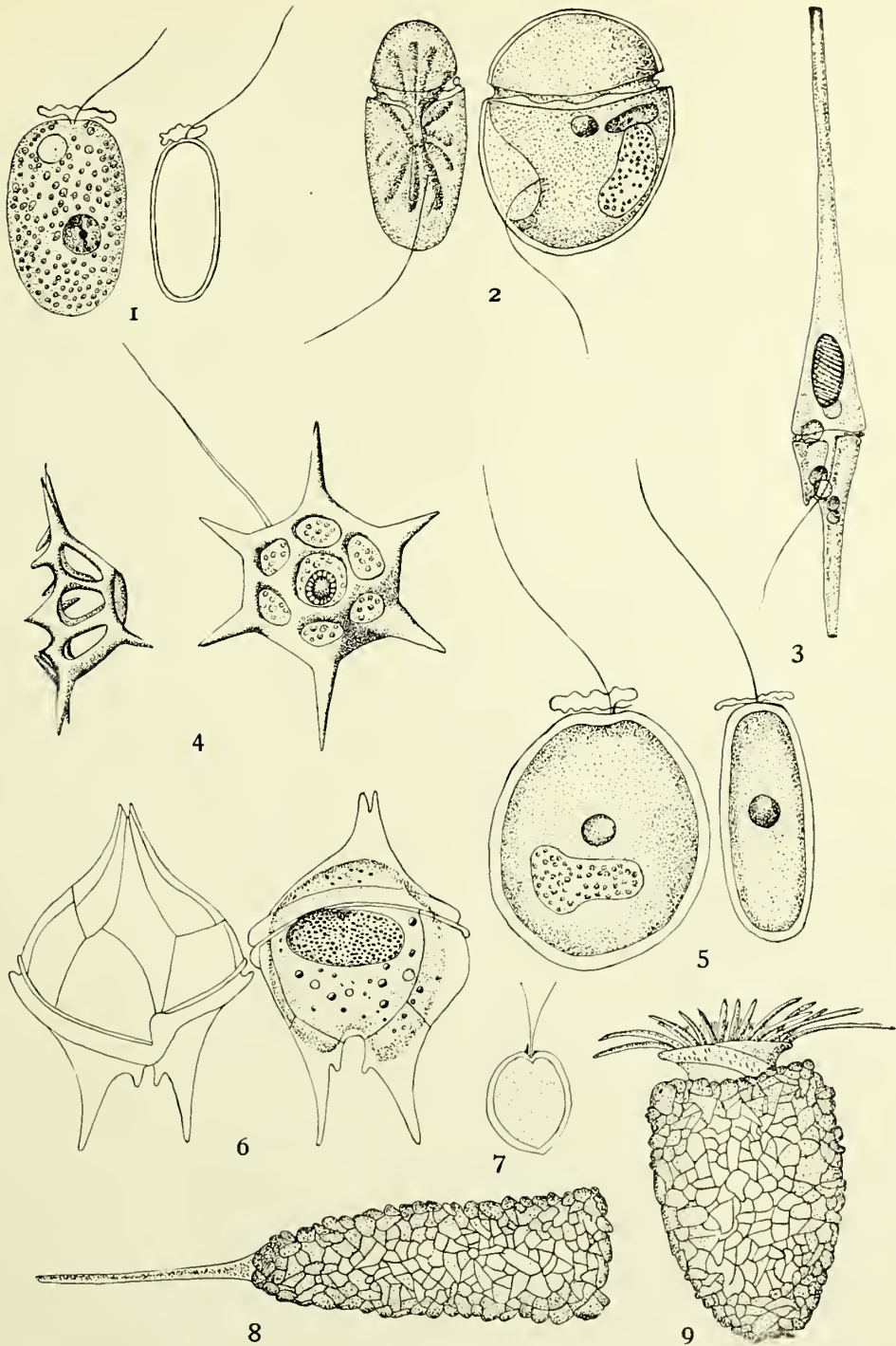

Organisms constituting the food of mussels. Protozoa. (All figures except 7 after Calkins.)

1. *Exuviaella marina* Cienkowski. $\times 780$.
2. *Glenodinium compressa* Calkins. $\times 822$.
3. *Ceratium fusus* Ehrenberg. $\times 315$.
4. *Distephanus speculum* Stohr. $\times 960$.
5. *Exuviaella lima* Ehrenberg. $\times 780$.
6. *Peridinium divergens* Ehrenberg. $\times 636$.
7. *Prorocentrum micans* Ehrenberg. $\times 375$.
8. *Tintinnopsis davidoffi* Daday. $\times 354$.
9. *Tintinnopsis beroidea* Stein. $\times 900$.

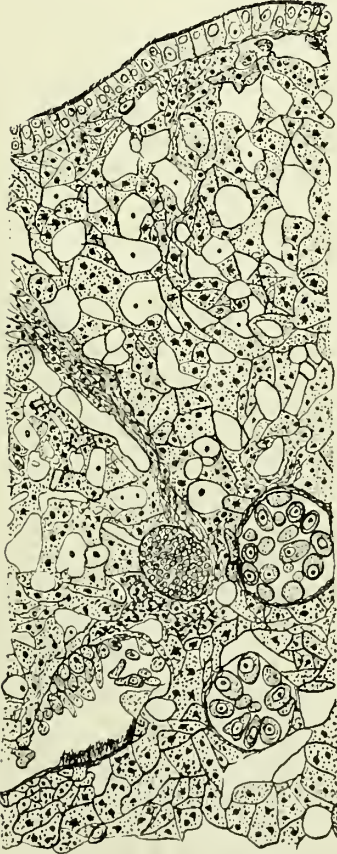
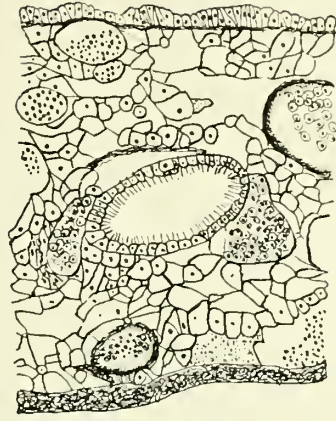

1. Cross section of the mantle of a female sea-mussel, March 4, 1908; fixed in Flemming's fluid and stained with Mayer's haemalum. X 150.
 2. Cross section of the mantle of a female sea-mussel, August 20, 1907; fixed in sublimite-acetic fluid and stained with Heidenhain's iron-haematoxylin. X 100.
 3. Cross section of the mantle of a male sea-mussel, June 27, 1908; fixed in Flemming's fluid and stained with Mayer's haemalum. X 105.
 4. Cross section of the mantle of a spent female sea-mussel, August 16, 1908; fixed in Flemming's fluid and stained with Mayer's haemalum. X 105.

4

2



1.—A mussel bed at Menemsha Pond, Marthas Vineyard, Massachusetts, exposed at low tide. (Photographed by Dr. R. W. Miner.)



2.—Dredging for mussels. This vessel operates on the ocean and bays from Princes Bay to Fire Island, and gathers from 200 to 250 bushels a day. (Photograph by courtesy of Mr. George A. Carman.)



1.—A heap of mussel shells, the result of a few days' work. (Photograph by courtesy of Mr. George A. Carman.)



2.—A heap of shells from mussels which have been pickled for the New York market. The shells are used as cultch for seed oysters. (Photograph by courtesy of Mr. George A. Carman.)

