

**DEWATERING OF DOMESTIC WASTE
SLUDGES BY CENTRIFUGATION**

**By
STERLING EUGENE SCHULTZ**

**A DISSERTATION PRESENTED TO THE GRADUATE COUNCIL OF
THE UNIVERSITY OF FLORIDA
IN PARTIAL FULFILLMENT OF THE REQUIREMENTS FOR THE
DEGREE OF DOCTOR OF PHILOSOPHY**

**UNIVERSITY OF FLORIDA
December, 1967**

68-13,031

**SCHULTZ, Sterling Eugene, 1934-
DEWATERING OF DOMESTIC WASTE
SLUDGES BY CENTRIFUGATION.**

**The University of Florida, Ph.D., 1967
Engineering, sanitary and municipal**

University Microfilms, Inc., Ann Arbor, Michigan

ACKNOWLEDGMENTS

I would like to express my sincere appreciation to Dr. H. D. Putnam, my committee chairman, who provided the guidance, assistance, and inspiration which were required to complete this dissertation. The support and contribution made by the other members of my committee, namely, Dr. C. I. Harding, co-chairman, Dr. A. P. Black, and Professor T. deS. Furman, are also gratefully acknowledged.

I am indebted to H. L. Crown who assisted me in carrying out this work. Appreciation is extended to Dr. W. H. Morgan, Dr. W. J. Nolan, J. Bramble, F. Janocha, Sara Kephart, and others for rendering valuable assistance when called upon for help. My thanks to Mrs. J. G. Larson for typing the final manuscript.

Sincere appreciation is extended to my wife, Shirlee, for her help and encouragement throughout the entire project.

Recognition and appreciation are extended to Bird Machine Company, South Walpole, Mass., for providing the 6 x 12 inch solid bowl centrifuge used in this work; Calgon Corporation, Pittsburgh, Pa., for supplying the CAT-FLOC cationic polymer; Dow Chemical Company, Midland, Mich., for supplying several cationic and anionic polymers; Rohm and Haas, Philadelphia, Pa., for supplying Primafloc C-7 cationic polymer; and the Department of Environmental Engineering, University of Florida, for financial support in the course of the project for equipment and material.

To the United States Air Force Academy, Department of Civil

Engineering, for the leave of absence; the Air Force Institute of Technology for support; and Headquarters U.S.A.F. for the active duty assignment to the University of Florida for this advanced degree, sincere appreciation is extended.

CONTENTS

	Page
ACKNOWLEDGMENTS	ii
LIST OF TABLES	vii
LIST OF FIGURES	xi
ABSTRACT	xv
 CHAPTER	
I. INTRODUCTION	1
II. HISTORICAL DEVELOPMENT	5'
First Centrifugal Dewatering in Germany	5
Centrifugal Dewatering in the United States	5
III. THEORETICAL CONSIDERATIONS OF CENTRIFUGAL SEPARATION, SLUDGE CHARACTERISTICS, AND CHEMICAL FLOCCULATION	13
Centrifugal Solid-Liquid Separation by Density Difference	13
Derivation of Theoretical Relationship	13
Application of the Sigma Concept	17
Sedimentation Performance Curve	19
Separation in the Continuous Solid Bowl Centrifuge	19
Sludge Characteristics	22
Colloidal Properties	23
Hydrophilic Colloids	24
Hydrophobic Colloids	25
Zeta Potential	25
Streaming Current	27
Colloid Stability	29
Chemical Flocculation	30
IV. EXPERIMENTAL EQUIPMENT, MATERIALS, AND PROCEDURES	34
Equipment	34
Bird Solid Bowl Centrifuges	34

	Page
Pilot Plant Equipment	38
Equipment Used at Treasure Island, Florida . . .	43
Equipment Used at St. Petersburg, Florida	44
Materials	45
Domestic Waste Sludges	45
University of Florida Sewage Treatment Plant . .	46
Water Pollution Control Plant, Treasure Island, Florida	46
Northeast Treatment Plant, St. Petersburg, Florida	47
Polyelectrolytes	50
Procedures	52
Sludge Preparation	52
Determinations on Feed Sludge, Centrate, and Cake	53
Laboratory Dewatering Tests	57
Experimental Design and Evaluation	59
Experimental Procedures	60
Data Recording and Calculations	64
V. RESULTS AND DISCUSSION	66
Introduction	66
Dewatering Digested Sludge	67
Experiment 1	67
Experiment 2	71
Experiment 3	72
Experiment 4	75
Experiment 5	77
Experiment 6	79
Experiments 7 and 8	80
Experiments 9 and 10	84
Experiment 11	88
Dewatering Activated Sludge	90
Experiment 12	90
Experiment 13	94
Experiment 14	98
Experiment 15	98
Experiment 16	101
Experiment 17	101

	Page
Experiment 18	103
Experiment 19	105
Experiment 20	108
Experiment 21	108
Dewatering Raw Sludge	111
Experiment 22	111
Experiment 23	117
Discussion	117
Machine and Process Variables	117
Sedimentation Performance Comparisons of Centrifuges	119
Comparison of 6x12 and 24x38 Inch Centrifuges . .	122
Comparison of 6x12 and 24x60 Inch Centrifuges . .	125
Characteristics of Sludges Dewatered	128
Polymer Dosage	130
Centrate Mobility, SCD Readings, and Residual Polymer	132
VI. CONCLUSIONS	134
APPENDICES	139
1. TABLES 13 THROUGH 34: TABULATED RESULTS OF ALL EXPERIMENTS	140
2. GLOSSARY	205
LIST OF REFERENCES	208
BIOGRAPHICAL SKETCH	215

LIST OF TABLES

Table	Page
1. Performance of Centrifuges Dewatering Domestic Waste Sludges	10
2. Polyelectrolytes Used in Laboratory Tests	51
3. Data Sheet	62
4. Calculation Sheet	65
5. Summary of Digested Sludge Experiments	68
6. Performance of 24 x 60 Inch Centrifuge Dewatering Digested Sludge, St. Petersburg, Fla.	89
7. Summary of Activated Sludge Experiments	91
8. Summary of Raw Sludge Experiments	112
9. Effect of Anionic and Cationic Polymers on Dewatering Raw Sludge at the University of Florida Sewage Treatment Plant	115
10. Sigma Values and Volumes for Three Centrifuges Used	121
11. Sigma Values in Square Inches for 6x12 Inch Centrifuge	122
12. Types of Centrifuges and Their Manufacturers in the U. S.	133
13. Effect of Feed Rate, Polymer Dose, and Location of Polymer Addition on Dewatering Anaerobically Digested Sludge at the University of Florida Sewage Treatment Plant	141
14. Effect of Polymer Dosage and Location of Polymer Addition on Recovery, Cake Solids, and Centrate Electrophoretic Mobility When Dewatering Anaerobically Digested Sludge at the University of Florida Sewage Treatment Plant	144

15.	Effect of Centrifugal Force, Polymer Dosage, and Location of Polymer Addition on Recovery, Cake Solids, and Centrate Electrophoretic Mobility When Dewatering Anaerobically Digested Sludge at the University of Florida Sewage Treatment Plant	146
16.	Effect of Three Cationic Polymers on Dewatering Anaerobically Digested Sludge When Dosages of Equal Cost Used to Dewater Anaerobically Digested Sludge at the University of Florida Sewage Treatment Plant	148
17.	Effect of Centrifugal Force, Polymer Dosage, and Location of Polymer Addition on Recovery, Cake Solids, and Centrate Electrophoretic Mobility and Streaming Current When Dewatering Anaerobically Digested Sludge at the University of Florida Sewage Treatment Plant	150
18.	Effect of Centrifugal Force, Pool Depth, and Sludge Feed Rate on Dewatering Anaerobically Digested Sludge at the University of Florida Sewage Treatment Plant	153
19.	Effect of Sludge Concentration, Centrifugal Force, Polymer Dosage, and Deep Pool Depth on Dewatering Anaerobically Digested Sludge at the University of Florida Sewage Treatment Plant	157
20.	Effect of Sludge Concentration, Centrifugal Force, Polymer Dosage, and Shallow Pool Depth on Dewatering Anaerobically Digested Sludge at the University of Florida Sewage Treatment Plant	160
21.	Effect of Pool Depth, Polymer Dosage, and Location of Polymer Addition on Dewatering Anaerobically Digested Sludge at the Water Pollution Control Plant, Treasure Island, Florida	163
22.	Effect of Feed Rate, Polymer Dose, and Location of Polymer Addition on Dewatering Anaerobically Digested Sludge at the Water Pollution Control Plant, Treasure Island, Florida	166

Table	Page
23. Effect of Feed Rate, Polymer Dosage, and Location of Polymer Addition on Dewatering Return Activated Sludge at the University of Florida Sewage Treatment Plant	169
24. Effect of Centrifugal Force, Feed Rate, and Polymer Dosage on Recovery, Cake Solids, and Centrate Electrophoretic Mobility and Streaming Current When Dewatering Return Activated Sludge at the University of Florida Sewage Treatment Plant	172
25. Effect of Centrifugal Force, Feed Rate, and Polymer Dosage on Dewatering Return Sludge from Extended Aeration Unit at the University of Florida Sewage Treatment Plant	175
26. Effect of Centrifugal Force, Feed Rate, Pool Depth and Polymer Dosage on Dewatering Return Sludge at the Water Pollution Control Plant, Treasure Island, Florida	178
27. Effect of Deep and Medium Pool Depths, Feed Rate, Polymer Dosage, and Polymer Dosing Rate on Dewatering Return Sludge at the Water Pollution Control Plant, Treasure Island, Florida	182
28. Effect of Centrifugal Force, Feed Rate, and Polymer Dosage on Dewatering Waste Sludge at the Northeast Sewage Treatment Plant, St. Petersburg, Florida	185
29. Effect of Polymer Dosage, Polymer Dosing Rate, and Location of Polymer Addition on Dewatering Waste Sludge at the Northeast Sewage Treatment Plant, St. Petersburg, Florida.	188
30. Performance of 24 x 60 Inch Centrifuge Dewatering Waste Sludge, St. Petersburg, Florida	192
31. Effect of Polymer Dosage and Polymer Dosing Rate on Dewatering Return Sludge at the Northeast Sewage Treatment Plant, St. Petersburg, Florida	194

Table

Page

32.	Effect of Feed Rate, Pool Depth, Polymer Dosage, and Polymer Dosing Rate on Performance of 24 x 60 Inch Centrifuge Dewatering Return Sludge, St. Petersburg, Florida	196
33.	Effect of Centrifugal Force, Polymer Dosage, and Location of Polymer Addition on Dewatering Raw Sludge at the University of Florida Sewage Treatment Plant	200
34.	Effect of Feed Rate, Polymer Dosage, and Location Polymer Added on Dewatering Raw Sludge at the Water Pollution Control Plant, Treasure Island, Florida	202

LIST OF FIGURES

Figure	Page
1. Past and Projected Trends in Domestic Sludge Production From Primary and Combined Secondary Treatment	3
2. Dewatered Sludge Volume as Per Cent of Original Sludge Volume at a Given Suspended Solids Concentration	3
3. Cross Section of a Cylindrical Centrifuge Bowl Showing the Separating Mechanism	16
4. Cross-Sectional View of Typical Cylindrical-Type Solid Bowl Centrifuge	21
5. Schematic Sketch of a Colloid Protein Particle Encased in Bound Water (From Rich, ⁵⁹ p. 136,)	26
6. Schematic Sketch of the Double Layer Around a Colloid Particle With a Negative Primary Charge. (From Rich, p.136)	28
7. Potentials Through the Electrostatic Field Surrounding a Charged Hydrophilic Colloid Particle. (From Rich, p. 138)	28
8. Bird Solid Bowl Continuous Centrifuge With Countercurrent Flow. Courtesy of Bird Machine Company, South Walpole, Mass.	35
9. Bird Solid Bowl Continuous Centrifuge With Concurrent Flow. Courtesy of Bird Machine Company, South Walpole, Mass.	37
10. Schematic Flow Diagram of Sludge Dewatering Pilot Plant, University of Florida	39
11. Bird 6x12 Inch Solid Bowl Continuous Centrifuge. Courtesy of Bird Machine Company, South Walpole, Mass.	41
12. Flowsheet of the Modified Contact Stabilization Process at the Water Pollution Control Plant, Treasure Island, Florida	48
13. Schematic Flow Diagram of the Northeast Sewage Treatment Plant, St. Petersburg, Fla.	49
14. Recurring Molecular Unit of Ionized CAT-FLOC	52

Figure	Page
15. Effect of Sludge Feed Rate, Polymer Dosage, and Location Polymer Added on Performance of 6xl2 Inch Centrifuge Dewatering Digested Sludge, University of Florida	70
16. Effect of Polymer Dosage and Location Polymer Added on Performance of 6xl2 Inch Centrifuge Dewatering Digested Sludge, University of Florida	73
17. Effect of Centrifugal Force and Polymer Dosage on Performance of 6xl2 Inch Centrifuge Dewatering Digested Sludge, University of Florida	74
18. Effect of Three Cationic Polymers and Location of Polymer Addition on the Performance of 6xl2 Inch Centrifuge Dewatering Digested Sludge, University of Florida	76
19. Effect of Centrifugal Force and Polymer Dosage on Electrophoretic Mobility and Streaming Current Response of Particles in Centrate When Dewatering Digested Sludge, University of Florida	78
20. Effect of Centrifugal Force, Feed Rate, and Pool Depth on Performance of 6xl2 Inch Centrifuge Dewatering Digested Sludge, University of Florida	81
21. Effect of Sludge Concentration, Centrifugal Force, and Polymer Dosage on Performance of 6xl2 Inch Centrifuge Dewatering Digested Sludge, University of Florida	82
22. Effect of Sludge Concentration, Centrifugal Force, and Polymer Dosage on Performance of 6xl2 Inch Centrifuge Dewatering Digested Sludge, University of Florida	83
23. Effect of Feed Rate, Polymer Dosage, and Location Polymer Added on Performance of 6xl2 Inch Centrifuge Dewatering Digested Sludge, Treasure Island, Fla.	85
24. Effect of Feed Rate, Polymer Dosage, and Location Polymer Added on Performance of 24 x 38 Inch Centrifuge Dewatering Digested Sludge, Treasure Island, Fla.	87
25. Effect of Feed Rate, Polymer Dosage, and Location Polymer Added on Performance of 6xl2 Inch Centrifuge Dewatering Return Activated Sludge, University of Florida	93
26. Effect of Centrifugal Force, Feed Rate, and Polymer Dosage on Performance of 6xl2 Inch Centrifuge Activated Sludge, University of Florida	96

Figure	Page
27. Effect of Centrifugal Force, Feed Rate, and Polymer Dosage on Performance of 6x12 Inch Centrifuge Dewatering Return Activated Sludge, University of Florida	97
28. Effect of Centrifugal Force, Feed Rate, and Polymer Dosage on Performance of 6x12 Inch Centrifuge Sludge From Extended Aeration Unit, University of Florida	99
29. Effect of Centrifugal Force, Feed Rate, and Polymer Dosage on Performance of 6x12 Inch Centrifuge Return Sludge, Treasure Island, Fla.	100
30. Effect of Feed Rate and Polymer Dosage on Performance of 24 x 38 Inch Centrifuge Return Sludge, Treasure Island, Fla.	102
31. Effect of Centrifugal Force, Sludge Feed Rate, and Polymer Dosage on Performance of 6x12 Inch Centrifuge Dewatering Waste Sludge, St. Petersburg, Fla.	104
32. Effect of Polymer Dosage, Polymer Dosing Rate, and Location of Polymer Addition on Performance of 6x12 Inch Centrifuge Dewatering Waste Sludge, St. Petersburg, Fla.	106
33. Performance of 24 x 60 Inch Centrifuge Dewatering Waste Sludge, St. Petersburg, Fla.	107
34. Effect of Polymer Dosage and Polymer Dosing Rate on Performance of 24 x 60 Inch Centrifuge Dewatering Return Activated Sludge, St. Petersburg, Fla.	109
35. Effect of Polymer Addition Rate, Sludge Feed Rate, and Polymer Dosage on Performance of 24 x 60 Inch Centrifuge Dewatering Return Activated Sludge, St. Petersburg, Fla.	110
36. Effect of Sludge Feed Rate and Polymer Dosage on Performance of 6x12 Inch Centrifuge Dewatering Raw Sludge, University of Florida	113
37. Effect of Feed Rate and Polymer Dosage on Performance of 24 x 38 Inch Centrifuge Dewatering Raw Sludge, Treasure Island, Fla.	114
38. Sedimentation Performance Versus Parameter $\frac{Q}{A}$ for Bird Solid Bowl Centrifuges Dewatering Digested Sludge	120
39. Sedimentation Performance Versus Parameter $\frac{Q}{A}$ for Bird Solid Bowl Centrifuges Dewatering Return Activated Sludge, Treasure Island, Fla.	124

Figure	Page
40. Sedimentation Performance Versus Parameter for Bird Centrifuge Dewatering Waste Sludge, St. Petersburg, Fla.	126
41. Sedimentation Performance Versus Parameter for Bird Solid Bowl Centrifuge Dewatering Waste Sludge, St. Petersburg, Fla.	127

Abstract of Dissertation Presented to the Graduate Council in
Partial Fulfillment of the Requirements for the Degree of
Doctor of Philosophy

DEWATERING OF DOMESTIC WASTE SLUDGES BY CENTRIFUGATION

By

Sterling Eugene Schultz

December, 1967

Chairman: Dr. Hugh D. Putnam
Major Department: Environmental Engineering

This research determined the effect of machine and process variables on dewatering domestic waste sludges by means of solid bowl continuous centrifuges. The machine variables were centrifugal force and pool depth. The process variables were sludge feed rate, sludge concentration, type of sludge, type of polymer, polymer dosage, polymer dosing rate and location of polymer addition. Factorial experiments to test the main effects and interactions of these variables were randomized block, split-plot and split-split-plot designs. Two replications were made on each treatment combination. The analysis of variance for each experiment was calculated by the IBM 360 computer at the University of Florida Computing Center. The AOV program is available at the Center's library.

The work was originally conducted on a pilot plant scale at the University of Florida Sewage Treatment Plant, using a 6x12 inch solid bowl centrifuge. Later in the investigation, the 6x12 centrifuge was taken to treatment plants having 24x38 inch and 24x60 inch machines, respectively.

Since maximum clarification and minimum cake moisture cannot be obtained simultaneously, the use of polyelectrolytes to obtain satisfactory clarity and cake solids dryness was an important part of this study.

Experiments were conducted on the same sludge with the three machines. The purpose was to defend the pilot plant work as valid by comparison to results obtained with full-scale equipment and to compare the performance of the three machines with the intent of using the results for scale-up work.

The experiments together with their analyses of variance determined that the machine and process variables are highly interdependent. Most of the two-factor interactions can be readily explained by graphical presentation of the data; therefore, the main effects of the variables can be discussed.

As centrifugal force increased, recovery of suspended solids increased for digested and raw sludges, and the concentration of the cake solids increased for raw, activated, and digested sludges. An intermediate centrifugal force increased recovery of suspended solids for activated sludge. As pool depth was increased, the recovery of suspended solids increased for all sludges and the cake solids concentration decreased for all sludges. As the sludge feed rate increased, recovery of suspended solids decreased exponentially for all sludges, and cake solids concentration increased for raw and digested sludges. Cake solids concentration for activated sludge decreased when the feed rate increased. As feed sludge concentration increased, the recovery of suspended solids

decreased and cake solids concentration increased for all sludges.

Sedimentation performance, based on the sigma concept, was chosen as the basis of comparison between the 6 inch and the 24 inch centrifuges. This technique, although subject to some criticism, provides a common denominator for comparing the centrifuges, and it is agreed that it is the most useful method.

Whenever comparative tests based on the uncorrected sigma factor could be made, the results showed that the 6x12 inch centrifuge duplicated or exceeded the performance of the larger machines dewatering digested and activated sludges. The sludge dewatering characteristics exhibited when centrifuged with the smaller centrifuge were very similar to those obtained with the larger machines. Hence, results of the pilot plant experiments can be used to predict results with full-scale equipment in the centrifugal force range of 650 to 3,000 times gravity.

The research revealed the need for productive investigation concerning the efficiency factors for scale-up from small to large machines, since for the comparisons made there was a loss of efficiency as the machine size increased.

CHAPTER I

INTRODUCTION

The centrifuge has intrigued sanitary engineers for many years as a method for dewatering domestic waste sludges. This interest is a result of successful centrifugal solid-liquid separations in the chemical process industries for more than a generation. Dewatering of sewage sludges was first tried in this country in 1920. The results were encouraging enough that additional experimental installations continued throughout the twenties and thirties. However, the centrifuge was not accepted in sewage treatment because of technological problems and failure to compete economically with sludge dewatering on drying beds.

The interest in mechanical sludge thickening and dewatering was intensified after World War II as the volume of solids to be disposed of increased exponentially as the population and economy expanded. Sludge disposal quickly became the most troublesome phase of sewage and industrial waste treatment, and today is still the most difficult problem in wastewater treatment.¹ America's continued population and industrial expansion, as well as the national goal for clean rivers and streams, has amplified the perplexing problem of sludge treatment and disposal.

With an urban population of well over 200 million forecast by 1980, and a national goal of secondary treatment for all municipal wastewater, the daily sludge volume will rise to more than 150 million gallons per day.² This represents a substantial increase when compared to the

1962 sludge volume of 50 million gallons per day.³

The past and future trends in domestic sludge production are shown in Figure 1 where it may be seen that as waste treatment improves with more advanced methods, a higher fraction of the soluble impurities is converted to more voluminous sludges. Because the specific gravity of sewage sludge solids is close to that of water, a significant sludge volume reduction accompanies the loss of water and the sludge volume changes approximately in the ratio of its solids concentration. Sewage sludges with a solids concentration in the range of one-half to eight per cent, undergo a remarkable volume reduction upon dewatering as illustrated in Figure 2. The potential value of thickening voluminous sludges prior to subsequent treatment and of dewatering sludges prior to ultimate disposal is apparent. Sludge thickening may be defined as the reduction in moisture content of the sludge in order to significantly decrease sludge volume while still maintaining its fluid properties. This definition excludes sludge dewatering where the purpose is to concentrate the suspended solids into a relatively dry sludge cake prior to ultimate disposal.

The methods for sludge thickening include: gravity thickeners^{4,5,6} for concentrating primary and secondary sludges or their mixtures; elutriation⁷ for thickening digested sludge prior to vacuum filtration; dissolved-air flotation^{8,9} for thickening secondary sludges; and centrifugation for thickening excess sludge wasted in the operation of activated sludge process.^{10,11,12,13,14}

The methods for sludge dewatering include: drying beds¹⁵ and sludge

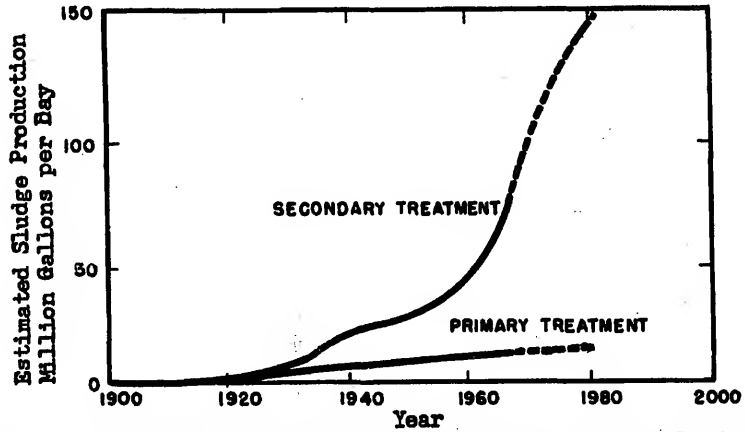

Fig. 1 - Past and Projected Trends in Domestic Sludge Production From Primary and Combined Secondary Treatment

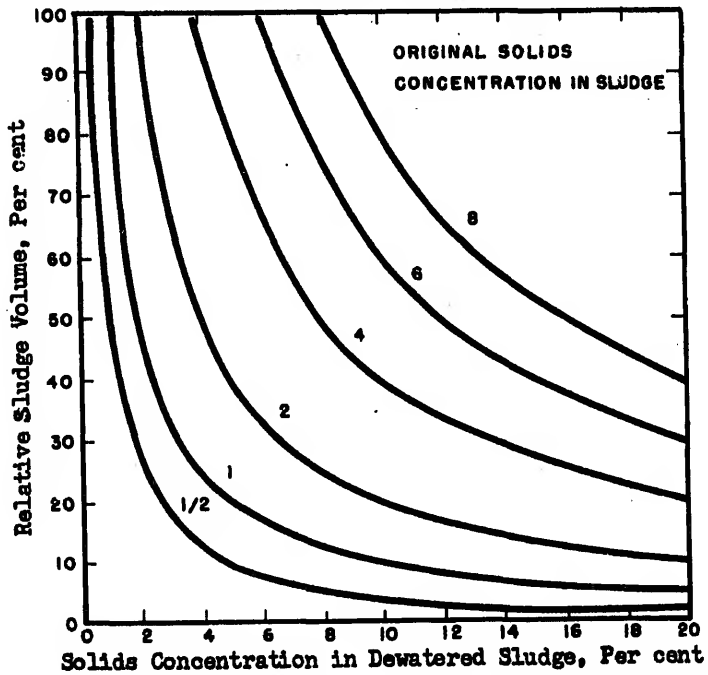

Fig. 2 - Dewatered Sludge Volume as Per cent of Original Sludge Volume at a Given Suspended Solids Concentration

lagoons¹⁶ for digested sludge; vacuum filters¹⁷ for raw and digested sludges; and centrifuges for all types of sewage sludges.¹⁸⁻²¹

Sewage treatment is a field in which the potential of centrifuges is just starting to be realized. Their first application was to assist existing equipment to forestall a plant expansion.^{10,13,19,22,23,24} Only the solid bowl continuous centrifuge proved to be successful in handling sewage sludges. Its continued success has been reported by engineers, centrifuge manufacturers, and treatment plant operators.^{21,25-33}

Regardless of the number of articles already cited on centrifuge performance, a great deal of hesitancy surrounds the use of the machine because the effect of the machine and process variables on the centrifuge performance have not been clearly defined for sewage sludges. In the past, centrifuging has been approached more as an art than as a science and has been called a "witch doctor's operation."^{*}

If centrifuges are to achieve their maximum potential in the field of sewage sludge dewatering, then the dewatering mechanism and the effects of the factors which influence centrifuge performance must be more clearly defined.

Therefore, this study was made to further centrifuge technology insofar as the process and machine variables affect the performance of the solid bowl centrifuge when dewatering domestic waste sludges.

* A statement made in a seminar at Georgia Institute of Technology, by Dr. W. W. Eohenfelder, Jr., Professor of Civil Engineering, University of Texas, April, 1967.

CHAPTER II
HISTORICAL DEVELOPMENT

First Centrifugal Dewatering in Germany

The first attempt to use a centrifuge for dewatering sewage sludge was made in 1902 by Herman Schaefer at Cologne, Germany. This centrifuge forced liquid through sieves by centrifugal force and after a definite number of rotations the dewatered cake was discharged. Later, Schaefer combined his efforts with Dr. Gustav-ter-Meer and under the latter's direction a much improved machine was designed and built. This machine, known as the Schaefer-ter-Meer centrifuge, was erected at Frankfort-on-the-Main, and was subjected to a series of performance tests for two years.³⁴

The first centrifuge installation for dewatering sludge at a sewage treatment plant was at Harburg, Germany, where two Schaefer-ter-Meer centrifuges were installed in 1907. Shortly after this, four were erected at Hanover and six at Frankfort-on-the-Main. Later, one machine was installed at the sewage works in Bielefeld, and one at Moscow.³⁵ These early machines were batch type, but operated continuously on an automatic cycle of filling, dewatering, and cake discharge.

Centrifugal Dewatering in the United States

An improved Schaefer-ter-Meer centrifuge was shipped to the United States and used at Milwaukee in 1920 for dewatering activated sludge. It was impossible to get a clear effluent (centrate) at an economical feed

rate and further improvements were made to the machine as a result of these tests. The machine was then sent to Baltimore in 1921. Tests were conducted at Baltimore on raw, semi-digested, and digested sludge. The relative ease of dewatering the sludges was in that order, with digested sludge being the easiest. Results were so promising that further improvements were made to the Schaefer-ter-Meer machine and in 1924 a continuous, automatically controlled, batch operation model was sent to Baltimore. Approximately 300 gallons of sludge were centrifuged per batch for 11 minutes. The inlet and outlet time required an additional 11 minutes. The average recovery of suspended solids was 65 per cent for digested sludge. Concern over the high solids content in the effluent from the centrifuge prompted studies to determine its effect on the BOD of the raw sewage influent to the plant and chemical precipitation of the solids. The influent biochemical oxygen demand, BOD, increased 4.3 per cent. The addition of 0.28 to 0.56 ounces of alum per gallon reduced the BOD of the centrate from 2815 to 1295 parts per million, but the BOD of the coagulated centrate was considerably higher than that of the untreated sewage.³⁴

From the centrifuge performance tests at Baltimore, it was concluded that sludge dewatering by centrifugation was a process worthy of consideration and study; however, if the process was to become widely accepted, a low cost method for further treating the centrate would be essential.³⁶

Raw sludge was dewatered at the Collingswood Sewage Disposal Plant in New Jersey in 1934. After two and one-half years of practical

service, several controlling factors of operation were reported very vaguely by Pecker:³⁷ (1) chemicals were of no aid in dewatering raw sludge; (2) best results were obtained with fresh sludge; (3) a reasonable pH variation was relatively unimportant; and (4) sludge cake production, recovery efficiency, and cake solids content increased directly with sludge concentration.

In 1939, a continuous feed, high speed (6,000 rpm) De Laval centrifuge was installed at Peoria, Illinois, for thickening waste activated sludge. Five months of testing ensued. The performance test results on activated sludge may be summed up as follows:^{38,39} (1) the sludge was thickened from 1 to 5 per cent; (2) the recovery averaged 75 per cent at an average feed rate of 30 gpm; and (3) the return of the centrifuge effluent to the aeration tanks did not seriously affect the operation of the activated sludge plant. Tests conducted on dewatering primary and digested sludges determined that they could not be handled because of their grit content. Approximately four machine shutdowns per day were necessary for cleaning clogged orifices and removing accumulations of sludge built up on the bowl wall. It was also recommended that an operator be present in the room with the centrifuge during operation.

In the years just prior to, and during World War II, only slight attention was directed toward centrifuging of sewage sludges. As Dr. F. Kiess⁴⁰ said in his review of sludge treatment in Germany, "the German people had other anxieties and urgent tasks than concerning themselves with the application of new ingenious methods for sludge dewatering." This statement applied equally as well to the United States.

The first report of centrifuging sewage sludges following the war was in 1950 when the performance of a De Laval disc centrifuge thickening waste activated sludge was tested at the Sioux Falls Sewage Treatment Plant in South Dakota.⁴¹ Following the successful testing program, two machines were reported to have been installed. The results of the testing program conducted at Sioux Falls were: (1) an 85 per cent sludge volume reduction was effected; (2) there was no detrimental effect on the primary clarifiers by returning the centrate to them; and (3) it was necessary to shut down for bowl cleaning once every 48 hours. Following publication of the original article there was much debate as to the benefits derived from thickening the sludge.^{33,34} The Sioux Falls Treatment Plant does not currently use any centrifuges for sludge dewatering.

Two unique circumstances provided the dramatic opportunity for centrifuges to prove their practicality in dewatering sewage sludges. The first occurred in 1954 at the Daly City Treatment Plant, California.¹⁸ This plant was of necessity constructed on a site surrounded by dwellings and business establishments. The consulting engineer selected centrifugal dewatering of digested sludge as the method most free from odors and least unsightly in appearance. A Bird 18 x 28 inch solid bowl continuous centrifuge was installed in 1954 and has operated successfully since then. Recently the 18 inch was replaced by a 24 x 38 inch Bird centrifuge when the plant capacity was expanded. A typical analysis of the present operation is in Table 1. No detrimental effects are incurred by returning the centrate to the primary clarifier; in fact, settling is enhanced by a synergism effect.

The second unique circumstance occurred in 1956 at the San Leandro, California, plant when three digesters had gone sour because of overloading. The resultant problem of maintaining plant operation concurrently with the handling of some 100,000 gpd of raw sludge, while the digesters were being emptied, was a formidable one. A 40 x 60 inch solid bowl Bird centrifuge emptied the sour digesters and dewatered the raw sludge.^{18,42}

These two successful applications of the solid bowl centrifuge revived the interest in their use for dewatering sewage and industrial wastes. Bird Machine Company reports more than 50 centrifuges currently operating at various sewage treatment plants throughout the United States.³⁰ Table 1 lists the current operating performance of centrifuges installed at seven municipal sewage treatment plants.*

In reviewing the history of centrifugal dewatering of domestic waste sludges, the factors which contributed to the unsuccessful application of centrifuges in the early installations were: (1) the high solids content in the centrate and an unwillingness to accept it; (2) low capacity throughput; (3) necessity to screen the sludge prior to centrifugation; and (4) a high percentage of down-time for maintenance.

The recent successful applications of the centrifuge to dewatering domestic waste sludges can be attributed to a number of factors including: (1) the acceptance of a less than "clear" centrate and the fact that the returned fines are not detrimental to some treatment processes; (2) improvement in the machines' operating characteristics brought about by

* This information was supplied by plant superintendents in reply to a questionnaire sent by the author.

Table 1
Performance of Centrifuges Dewatering Domestic Waste Sludges

Location*	A	B	C	D	E	F	G
Centrifuge**	---	40 x 60	24 x 38	24 x 38	---	24 x 38	---
Treatment	Primary	Primary	Aeration	Digested	H.R.T.F.	Act. Sludge	Primary
Sludge	Digested	Digested	Digested	Digested	Digested	Waste Act.	Digested
Feed sludge	9.2	4.8	4-12	6-8	3-7	0.47	4.5
TS%	---	4.5	---	---	---	---	---
SS%	37.1	59	30-45	54	55-65	69	58.4
VS%	7.0	7.1	---	7.1	7.0-7.4	---	7.0
pH	2815	2600	---	3600	---	90	3200
Alkalinity	---	---	22-40	---	---	---	---
Feed rate, gpm	---	---	---	---	---	---	---
Concentrate	3.1	3.4	1.2-3.7	1.5-2.6	2-3	---	1.4
TS%	---	3.0	---	---	---	0.27	---
SS%	62	59	62-68	80	64-75	---	---
VS%	71	37	72-77	65-72	50	45	73
Recovery %	45.7	37.8	28-35	30.5	20-30	5.1	25
Cake solids	29.0	21.1	18-39	40-43	35-50	64.1	---
TS%							
VS%							

Table 1 - Continued

Location*	A	B	C	D	E	F	G
Polymer	---	---	---	---	---	---	---
Times gravity	1333	875	---	---	1350	---	1350
Pool depth (inches)	2,25	3.0	---	4	2 1/2	3 7/8	2 1/4
Operating time Hr/d, D/wk	6;5	24;7	8hr/day	6hr/wk	14hr/wk	Varies	24;6
Cake disposal	Land fill	Drying beds	---	Land fill	Land fill	Drying beds	Barged to sea
Location centrate returned	Influent	Ocean outfall	---	Influent	Sludge drying beds	Aeration tank	Pre-aeration tank
Effect of centrate	Unknown	---	---	Beneficial	Disastrous	Unknown	None
Years operated	---	8	5	11 1/2	7	2	4

* A - Atlanta, Ga., B - Anonymous, C - Manitoba, Canada, D - Daly City, Calif., E - San. Dist. No. 6, Sacramento County, Carmichael, Calif., F - San Antonio Leon Creek Plant, Texas, G - Joint Plant (county of Westchester) Yonkers, N. Y.

** Size of Bird centrifuges installed (bowl size: diameter times length in inches).

keen competition among sludge handling equipment manufacturers; and

(3) the recent increase in research and publication of results on centrifugation which is making more sanitary engineers aware of this method for dewatering sludge.

CHAPTER III

THEORETICAL CONSIDERATIONS OF CENTRIFUGAL SEPARATION, SLUDGE CHARACTERISTICS, AND CHEMICAL FLOCCULATION

Centrifugal Solid-Liquid Separation by Density Difference

Despite the fact that centrifuging is one of the oldest unit operations, many empirical factors still have to be introduced into the estimation of centrifuge performance. The accepted mathematical treatment for evaluating centrifuge performance is presented in this section. Special reference to the assumptions that are generally made in arriving at that estimate is included. The author wishes to give special recognition to Charles M. Ambler, G. A. Frampton and M. E. O'K. Trowbridge whose published articles contributed the following theoretical relationships. ⁴³⁻⁴⁶

Derivation of Theoretical Relationship

When a force is applied to a particle in a fluid medium, the particle is accelerated, $F=ma$, until it reaches a velocity along the line of the force at which the resistance to its motion equals the applied force. In a settling tank this force is gravity. In a centrifuge, this force is the centrifugal force, $F = m\omega^2 r$ dynes, created by the centrifuge bowl spinning at ω radians per second at a radius of r centimeters from the axis of rotation, which obviously varies as the particle moved under its influence. Allowing for particle buoyancy in the suspending medium, the absolute mass, m , becomes the effective mass, $V(\rho - \sigma)$, where ρ and σ are the density of the particle and fluid medium respectively, and V is

the particle volume.

If the particle is spherical, its volume is $\pi D^3/6$; if it is not spherical, its diameter, D, must be postulated statistically such that its volume is still $V = \pi D^3/6$. Then the force producing motion is

$$F(\text{dynes}) = \frac{\pi D^3}{6g} (\rho - \sigma)\omega^2 r \quad (1)$$

Movement of the particle under the influence of this force is immediately hindered by the resistance of the fluid medium to motion through it. For small particles moving at moderate velocities (below the turbulent range), the resisting force is proportional to the velocity of the moving particle, and for the particular case of a spherical particle is defined by Stokes' law as

$$R(\text{dynes}) = 3\pi\eta Du$$

in which η is the absolute viscosity of the liquid.

The particle accelerates until it reaches a terminal velocity where the centrifugal force producing motion and the viscous resistance to motion balance each other, then

$$\frac{\pi D^3}{6g} (\rho - \sigma)\omega^2 r = 3\pi\eta Du$$

and solving for the particle velocity

$$u = \frac{D^2 (\rho - \sigma)\omega^2 r}{18g} \quad (2)$$

Since the centrifuge capacity is usually limited by its ability to handle the smallest particles that settle slowly in a given system, the formula becomes of major importance in the analysis of centrifuge performance.

For a simplified approach to a study of this system, consider a cylindrical centrifuge bowl carrying a relatively thin liquid layer of thickness S at a rate Q c.c./sec. through the bowl. See Figure 3. It is usual to assume the velocity of a particle, μ , as constant across such a layer, so that the radial distance traveled by the particle in time t seconds is x centimeters where

$$S = ut = \frac{D^2 (\rho - \sigma) \omega^2 r t}{18 \eta g}$$

It is further assumed with much less justification⁴⁵ that $t = V/Q$, where V = volume of liquid in the bowl at any given moment and Q is the volumetric rate of flow in comparable units. The radial distance traveled by the particle may now be written

$$x = \frac{D^2 (\rho - \sigma) \omega^2 r}{18 \eta g} \frac{V}{Q}$$

If x is greater than the initial distance of the particle from the bowl wall, it will be removed from the liquid phase; otherwise it will remain in suspension and be discharged with the centrate. To insure elimination of the particle from the centrifuge, the distance x must be equal to at least the thickness of the liquid layer in the bowl. Thus

$$x = S = r_2 - r_1 = \frac{D^2 (\rho - \sigma) \omega^2 r}{18 \eta g} \frac{V}{Q} \quad (3)$$

$$Q = \frac{1}{18} \frac{D^2 (\rho - \sigma)}{\eta g} \frac{\omega^2 r V}{S} \quad (4)$$

which can be written as

$$Q = KX \leq \quad (5)$$

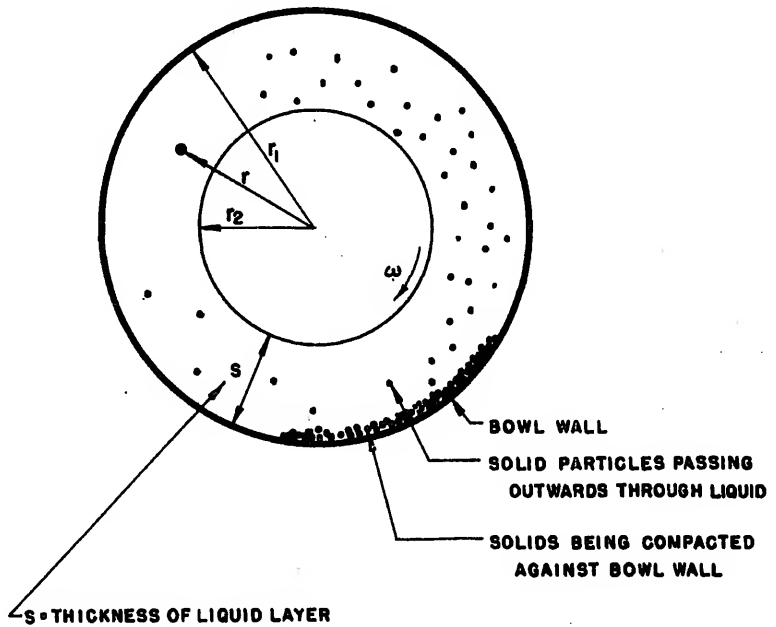

Fig. 3 - Cross Section of a Cylindrical Centrifuge Bowl Showing the Separating Mechanism.

where $k = \text{constant}$

$$X = \frac{D^2 (\rho - \sigma)}{\eta}$$

containing only data relating to the materials being separated

$$= \frac{\omega^2 r V}{g S}$$

containing only data relating to the centrifuge itself

Ambler⁴³ has named this \neq entity sigma, which can be defined as the area of a gravity settling tank of equivalent separating power to the centrifuge.

Its value depends solely upon the centrifuge parameters, which can be divided into two factors, one concerned with the field force generated by the machine, and the other with its geometry, thus:

$$\Sigma = \frac{\omega^2 r}{g} \cdot \frac{V}{S} \quad (6)$$

This particular approach to centrifuge performance has come to be known as "Sigma Theory."⁴⁶ From equations (4) and (6), the maximum throughput at which a particle of a given size will be eliminated from the feed stream of any given centrifuge can be expressed as

$$Q = \frac{1}{18} \cdot \frac{D^2 (\rho - \sigma)}{\eta} \quad (7)$$

Equation (7) holds only on the condition that (a) the system behaves in accordance with Stokes' Law and (b) that a true value for Σ can be found. A thorough examination of these assumptions and the reasoning in arriving at the value for correction factors are available.^{45,47}

Existing commercial centrifuges do not approach the idealistic performance indicated in equation (7). But the amount by which a machine falls short of this performance is characteristic to each kind of centrifuge.⁴⁵

Application of the Sigma Concept

The assumptions and conditions which were set forth as the basis of deriving equations 1, 2, 4, and 7 impose limitations to the application of the Σ concept. The assumptions concerning the feed material are the following:

1. Particles are spherical in shape and uniform in size. They are not to deaggregate, deflocculate, coalesce, or flocculate during

separation.

2. Particles are evenly distributed in the continuous liquid phase and settle as individual particles.

3. The settling velocity of the particles is such that the Reynolds number does not exceed one.

Assumptions concerning the flow conditions are:

1. Streamline flow with uniform distribution of the feed in the full liquid layer.

2. The layer of the deposited solids do not disturb the flow pattern and remixing of the deposited solids does not occur.

Theoretically, the sigma concept allows performance comparison between geometrically and hydrodynamically similar centrifuges operating on the same feed material. This is frequently made use of in scaling up to a full size machine from results on a laboratory or pilot plant centrifuge. Equation 7 shows that the sedimentation performance of any two similar centrifuges treating the same suspension will be the same if the quantity $\frac{Q}{\Sigma}$ has the same value for each.

From equation (7) we may write

$$\frac{Q_1}{\Sigma_1} = \frac{1}{18} \cdot \frac{D^2 (\rho - \sigma)}{\mu}$$

and for a given degree of separation on a given feed material the expression $\frac{1}{18} \cdot \frac{D^2 (\rho - \sigma)}{\mu}$ is a constant for the laboratory or pilot centrifuge. Hence, to carry out the same degree of separation in centrifuges (1), (2), and (3), they must be operated at a throughput to satisfy the condition:

$$\frac{Q_1}{\Sigma_1} = \text{Constant} = \frac{Q_2}{\Sigma_2} = \frac{Q_3}{\Sigma_3} \quad (8)$$

Sedimentation Performance Curve

To transfer the performance results from one centrifuge to another the ratio $Q/\bar{\epsilon}$ versus fraction of solids un sedimented is plotted on logarithmic probability paper in the indicated order, where Q is the flow rate in any convenient unit and σ is the performance factor in units consistent with Q .⁴⁴

According to the principles presented above, if the system is ideal, that is to say it has a stable particle size and its clarification properties are determined by the settling power of the centrifuge, all centrifuge performance data should fall on the same line as $Q/\bar{\epsilon}$ versus fraction of solids un sedimented. When the curve for a particular machine deviates from a straight line, it is an indication that the σ correlation has broken down, and, therefore, extrapolation from one machine to another is recommended only on the straight-line portion of the curve.

Separation in the Continuous Solid Bowl Centrifuge

In the continuous solid bowl centrifuge with conveyor discharge, the mechanism of the separation in the pool consists of sedimentation hindered by five disturbing factors:⁴⁵ (1) solid cake layer moving along the bowl wall, occupying space, and influencing the residence time for the liquor, and the radial distance of travel for sedimenting particles; (2) space occupied by flights of the conveyor which reduces the residence time; (3) turbulence created by the relative motion of conveyor to bowl; (4) a liquid flow pattern which is complex and difficult to assess as it takes a spiral path around the conveyor flights in its passage in an axial direction toward its discharge point; and (5) hindered settling of the solids as they approach the cake surface in a slurry of high concentration.

Frampton⁴⁵ calculates corrections for these five disturbing factors for Sharples Super-D-Canter* centrifuges.

Initially ignoring these five disturbing factors, it is possible to calculate a sigma value for the pool section of a cylindrical type bowl with a conical section.⁴⁶ This type of solid bowl centrifuge is illustrated in Figure 4. The theoretical value of Σ is given by the equation

$$\Sigma = \frac{2\pi\omega^2 r_1 (3r_2^2 + r_1^2)}{g \cdot 4} + \frac{2\pi\omega^2 r_2 (r_2^2 + 3r_2 r_1 + 4r_1^2)}{g \cdot 8} \quad (8)$$

The formulae for sigma values are of utility in comparing the capacities of machines having the same conveying velocity and configuration. Hence, as a design tool within a limited field they have utility, but in general the treatment represents too great an over-simplification to be satisfactorily applied to scaling-up.⁴⁶ Practical operation of continuous bowl centrifuges is guided in general by the above theoretical considerations but actual performance cannot be predicted by them alone. For this reason, the experience factor is still basic to proper application.²¹

The dewatering mechanism in the solid bowl conveyor discharge centrifuge is the most complex; therefore, the scaling-up of this class of equipment should be treated with great caution by those not widely experienced in centrifuge technology.⁴⁶

*Manufactured by Sharples-Equipment Division, Pennsalt Chemicals Corporation, Warminster, Pa.

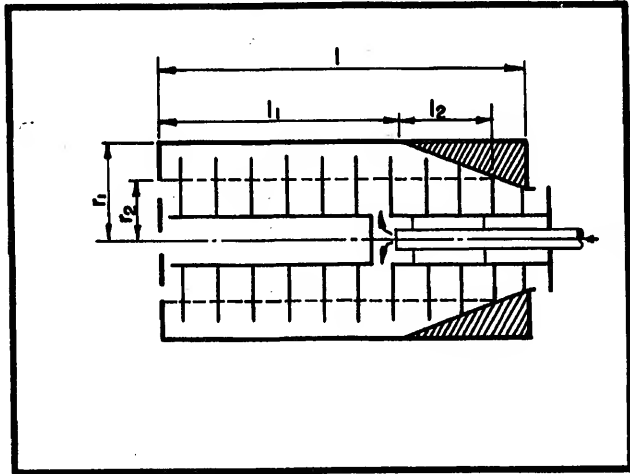

Fig. 4 - Cross-Sectional View of Typical Cylindrical-Type Solid Bowl Centrifuge.

Sludge Characteristics

The sludge characteristics which affect centrifugal dewatering are: (1) size, shape, density, and charge of the solid particles; (2) viscosity of the sludge concentrate; (3) compressibility of the solid particles; (4) solids concentration; and (5) chemical composition of the sludge.

The size, shape and density of the solid particles have a profound effect on their sedimentation by centrifugal force. From equation (2) it is apparent that the settling velocity and therefore the clarifying capacity of a given centrifuge will increase with increased particle size, greater solid-liquid density difference, and decreasing liquid viscosity. The sludge solids are generally amorphous and compressible in the size range of 200 microns and less.⁴⁸ Such materials dewater primarily by expulsion of water as the solids compact against the bowl wall.²¹ The larger non-compressible solids dewater as liquid flows through the conveying cake.

The viscosity of the sludge water is of academic interest in most cases, since no advantage can be taken from the inverse relationship of viscosity to temperature.

Moyers reports that centrifugal separation is easier with slurries of high solids concentration.⁴⁹ If this effect is true for sewage slurries, it has not been reported.

The sludge chemical composition affects the amount of chemical required for improving the dewatering characteristics of a sludge. Genter⁵⁰ has shown that two factors should be considered; namely, (1) the bicarbonate alkalinity of the liquid, and (2) the ratio of the volatile matter

to ash. However, a direct correlation between chemical requirements of these factors is not always attainable, and in fact, the physiological characteristics of the sludge and the particle size seem to be more significant in determining the chemical requirements.⁵¹ Bargman⁵² singled out particle size as the most important measurable property distinguishing between good and poor filter rates at ten treatment plants using vacuum filters. Rudolfs and Balmat⁴⁸ claim that the colloidal fraction exerts one-third of the chemical demand but represents only one-sixth of the total solids on a gravimetric basis. The chemical composition of sludge is determined by the source of the sludge and the process of formation. Exhaustive investigations have been accomplished to determine chemical composition of sludge.^{53,54} Regardless of the relative roles of the chemical and physical properties of the sludge, it is well known that the various sewage treatment processes produce sludges that have varying dewatering characteristics. Colloidal behavior is the one common denominator of all sewage sludges which is responsible for their dewatering character.

Colloidal Properties

Domestic waste sludges are complex colloidal systems consisting of (1) colloidal particles with mean diameters from ten angstroms to one micron; (2) supra-colloidal particles with mean diameters from one to 100 microns; and (3) large particles which are aggregates of hydrophilic colloids.⁵⁵ Experiments performed by Weisburg⁵⁶ indicate that most colloidal particles separated from raw sewage were hydrophobic. Primary sedimentation removed 50 per cent of these hydrophobic colloids from the

raw sewage. They settled as loose aggregates and contributed to the formation of the sludge. The supra-colloidal solids and larger aggregates of hydrophilic particles comprised approximately 90 per cent of the total raw sludge solids. The contributions of particulate fractions to the total suspended solids in sewage are respectively, 52, 42, and 6 per cent for settleable, supra-colloidal, and colloidal fractions.⁵⁴ Micro-sieve analysis of activated sludge by Kennedy *et al.*⁵⁷ showed that between 28 and 72 per cent of the suspended solids had a mean diameter of 45 microns. Wet screen analysis of elutriated mesophilic digested sludge showed that 80 per cent had a mean diameter less than 74 microns.⁵¹

Hydrophilic Colloids

Hydrophilic colloids in sewage may be proteins, their products of hydrolytic decomposition, and other organic compounds of biological origin. The primary charge on the hydrophilic colloid is due to the reactive amino and carboxyl groups in the molecules of these biological substances. In water, the amino group hydrolyzes and depending on the pH of the system one or both of the groups dissociates.⁵⁸ With the central molecular structure represented by the symbol, R, the dissociation can be depicted by the following expression:

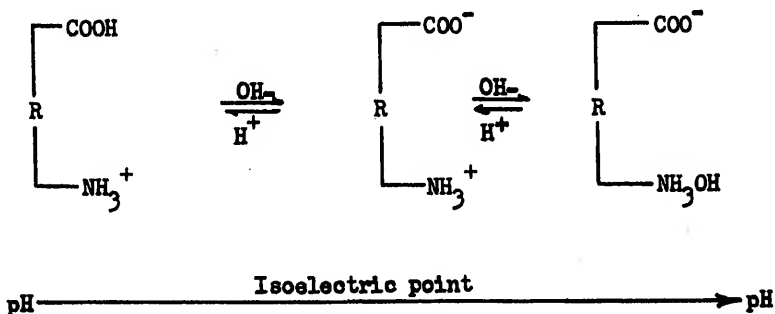

A pH increase from the isoelectric point depresses the ionization of the hydrated amino group and results in net negative charge. A decrease in pH from the isoelectric point depresses the ionization of the carboxylic group and results in a net positive charge.⁵⁹

The hydration of hydrophilic particles is dependent on the same functional groups, -OH, -COOH, and -NH₂, and the structure of the molecules. These functional groups being water soluble, hold a sheath of water firmly around the particle (bound water). Figure 5 is a schematic sketch of a protein particle of colloidal size showing the particle encased in its bound water. The particle with its bound water envelope moves as a single unit.⁵⁹

Hydrophobic Colloids

Hydrophobic colloids in sewage are usually inorganic and negatively charged. They have no affinity for water. Therefore, hydrophobic colloids are not encased in bound water.

The primary charge on a hydrophobic colloid particle is thought to be the result of preferential adsorption of solution ions on the particle surfaces. However, since the particle charge can be reversed by a change in pH, it has been postulated that adsorption of either H⁺ or OH⁻ ions is responsible for the primary charge on the particle.^{59,60}

Zeta Potential

The primary charge on either hydrophilic or hydrophobic colloid particles attracts solution ions of opposite charge. As a result, oppositely charged ions increase in the immediate vicinity of the particle. If the primary charge is sufficiently large, a compact layer of counterions forms adjacent to the particle, called the Stern layer or

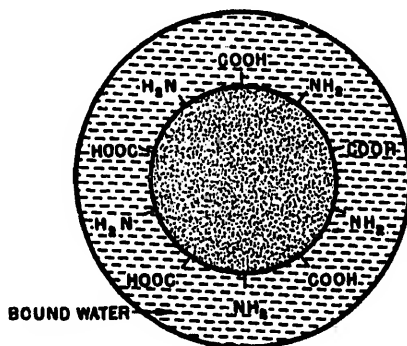

Fig. 5 - Schematic Sketch of a Colloid Protein Particle Encased in Bound Water. (From Rich,⁵⁹ p. 136.)

compact double layer. Brownian movement and induced velocity gradients prevent the Stern layer from establishing electroneutrality and fluid motion diffuses counterions into the solution proper.⁶¹ The region between the Stern layer and the solution proper is called the Gouy-Chapman layer or diffuse double layer. The counterion concentration in the diffuse layer varies from a relatively high level at the fixed diffuse boundary gradually out to the concentration of ions in the bulk of the solution where electroneutrality with the counterions exists. Figure 6 is a schematic sketch of the double layer surrounding a colloid particle

with a negative primary charge.

Concentration differences between cationic and anionic species result in the establishment of an electrostatic field around the particle. The potentials through the electrostatic field of a negatively charged colloidal particle are illustrated in Figure 7.

The electrochemical potential is the potential across the entire ionic double layer at the solid-liquid interface.^{60,62,63} Zeta potential is the potential gradient over the Gouy-Chapman diffuse layer, or simply the potential at the plane of shear. This plane forms a boundary between that portion of the solution around the particle that moves with the particle and the portion which can move independently of the particle.

The shear plane around hydrophilic colloid particles coincides with the exterior boundary of the bound water, but for hydrophobic colloids the plane of shear is located near the boundary between the fixed layer and the diffuse layer.^{59,64,65} The exact location of shear plane is debatable.⁶¹ By using electrophoretic mobilities, measurable by a number of techniques, the zeta potential can be determined.^{66,67}

Streaming Current

The walls of a capillary or annulus through which a colloidal suspension is forced to flow will quickly take on the charge characteristics of the colloidal particles present in the liquid. This effect is nearly instantaneous and reversible.⁶⁸ When the particle with its fixed and diffuse layers of charges attaches to the wall and the liquid is forced to flow past, the mobile counterions separate from the particle at the shear plane and are physically swept downstream. This movement of like electrical charges is an electrical current and is called the streaming

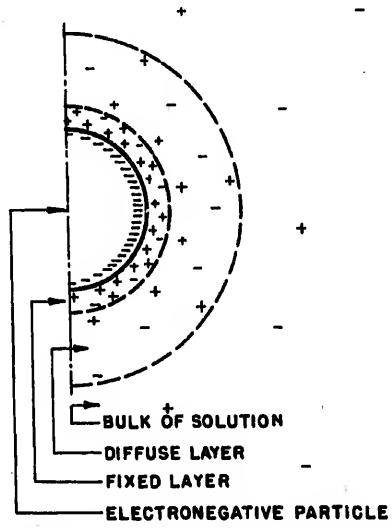

Fig. 6 - Schematic Sketch of the Double Layer Around a Colloid Particle With a Negative Primary Charge. (From Rich, p. 136.)

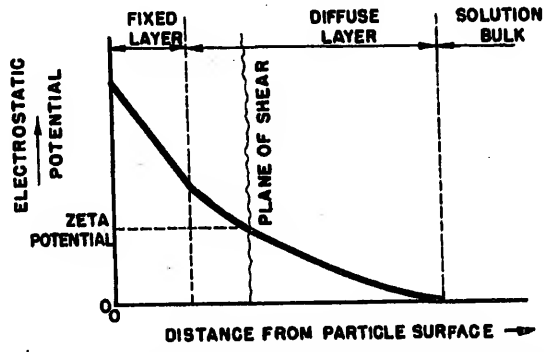

Fig. 7 - Potentials Through the Electrostatic Field Surrounding a Charged Hydrophilic Colloid Particle. (From Rich, p. 138.)

current. If the flow system is made of non-conducting materials, this current will be forced to return by ohmic conduction through the streaming liquid. Polarity is such that when a pair of electrodes is inserted upstream and downstream of the flowing charged particle, the upstream electrode has the same sign as the electrical charge on the particle. The movement of the particles (along with their counterions) through the capillary or annulus does not contribute to the streaming current. The streaming current results from the physical separation of counterions from charged particle surfaces, and this occurs only in the case of charges immobilized on the surface of the capillary or annulus. Gerdes⁶⁸ mathematical derivation for streaming current is explicitly for the condition of alternating flow.

Colloid Stability

Colloid stability depends upon the net resultant of the forces of attraction and repulsion acting on the colloid. A colloid system is said to be stable if the colloidal condition is more or less permanent.

The two most important forces of instability are Brownian movement and van der Waals' forces of attraction. Brownian movement is imparted to the suspended particles by their collision with rapidly moving molecules of the suspending liquid. Van der Waals' forces are weak forces of attraction between atoms and/or molecules. They are caused by permanent or induced dipole features of the particle molecules and are similar to polar bonds. When two particles having dipoles meet with the appropriate orientation they attract one another.⁶⁹

The forces of repulsion in a hydrophobic colloidal system are attributed directly to the zeta potential. The stability of hydrophobic

colloids can be destroyed by neutralizing or reducing the zeta potential on the particle surfaces. The stability of hydrophilic colloids is attributed to the repulsive force of zeta potential and the bound water which acts as an elastic barrier to keep the particles from coming together. In order to reduce the stability of hydrophilic colloids, one or both of these factors must be removed at least partially.

Chemical Flocculation

Chemical conditioning is done to improve the dewatering characteristics of the sludge. The conditioning process implies a flocculation reaction wherein individual sludge particles are united into rather loosely bound agglomerates, or flocs, thereby increasing the effective particle size.

Chemical reagents are classified as flocculants when they react with suspended matter at the solid-liquid interface and thereby affect colloid stability. Chemical flocculants are salts, surfactants, colloids, and natural or synthetic polymers.⁶¹

Flocculants alter the sludge particle properties through one or a combination of three mechanisms: (1) reduction or neutralization of the zeta potential; (2) dehydration of bound water; and (3) extensive ionic cross-linking or bridging of particles by synthetic, long-chain, high molecular weight polymers.

The zeta potential of both hydrophilic and hydrophobic colloids can be reduced by adjusting the pH of the system toward the isoelectric point. At the isoelectric point the primary charge is zero and no double layer exists to produce a zeta potential.

The zeta potential can also be reduced by adding ions or colloids of opposite charge to the colloidal system. The addition of counterions serves to increase the concentration of counterions in the fixed double layer, and the zeta potential is reduced.

Reduction of the zeta potential depends upon the valence of the opposite charged ions by the Schulze-Hardy rule. According to Schulze-Hardy, a bivalent ion is 50 to 60 times more effective than a monovalent ion, and a trivalent ion is 700 to 1,000 times more effective than a monovalent ion.⁷⁰ The colloid stability is effected only slightly by the chemical nature of the common ion or its valence charge.⁶⁴

The bound water of hydrophilic colloids can be reduced by adding salts in high concentration. The anions of the salt compete with the colloid particles for the bound water. The effectiveness of dehydration depends on the nature of the anions added according to the Hofmeister series.⁵⁶ The Hofmeister series lists the following anions in order of decreasing effectiveness:⁵⁹ $\text{SO}_4^{=}$, Cl^- , NO_3^- , I^- .

Colloids can be flocculated through the addition of polyelectrolytes. These materials are high molecular weight, long-chained, organic polymers with a multitude of repeating functional groups along the chain length.⁷¹ The length of the polymer molecule extends into the colloid size.⁷² When the polymer is dissolved in water the functional groups ionize. Anionic polyelectrolytes contain acidic groups and when dissolved in water positive ions will ionize off the polyelectrolyte chain, leaving the functional sites negatively charged. Cationic polyelectrolytes contain basic groups and when ionized, the negative ions leave the chain and the sites are positively charged. Non-charged polymer chains are

called nonionic polyelectrolytes.

The size and shape of a polyelectrolyte in solution depends on the net charge of the polymer as influenced by the pH, the nature of the polymer, and the ionic valence in accordance with the Schulze-Hardy rule. The uncharged molecule is like a contracted chain. The electrically charged chain can be visualized as a random coil whose length has increased due to mutual repulsion of charged sites along the chain.

When used as flocculants, high molecular weight polyelectrolytes function according to the principles of mutual coagulation of sols.⁶⁵ The polymer rapidly diffuses to the surface of the oppositely charged particles and is adsorbed by the process of ion exchange where it is dehydrated and neutralized along with the oppositely charged surface. Because of the polymer chain length, the polymer-particle interaction is more efficient than that of mutual coagulation of spherical particles.

The polymer chain may attach itself to several particles and establish a bridge between them. This can occur also between particles held by other polymer molecules, thereby cross-linking of polymer chains occurs. This process short-circuits the classical flocculation processes by building a floc via coulombic rather than by van der Waals' forces. The flocculation rate is increased, the floc is tougher, and the agglomerated particles settle more rapidly.

Even though complete neutralization of colloidal charges may not always be necessary, the optimum polymer dosage depends primarily on the surface charge density of the colloid, which can be determined electrophoretically.⁶¹ Because this value is an average quantity and depends on

the total weight of solids, dosage can be expressed as weight per cent or pounds per ton.

CHAPTER IV

EXPERIMENTAL EQUIPMENT, MATERIALS, AND PROCEDURES

Equipment

Bird Solid Bowl Centrifuges

The continuous solid bowl centrifuges in this study were commercial machines manufactured by Bird Machine Company, South Walpole, Mass. Bird centrifuges for dewatering domestic waste sludges are classified as countercurrent flow or concurrent flow. In the first type solids and liquid pass through the bowl in opposite directions, whereas in the latter (concurrent flow) the solids and liquid pass through the bowl in the same direction.

Countercurrent flow solid bowl centrifuge - The Bird continuous solid bowl centrifuge with countercurrent flow is illustrated as a cut-away drawing in Figure 8. The two principal elements of this centrifuge are the (a) rotating bowl which is the settling vessel and the (b) conveyor which discharges the settled solids. The bowl has (c) adjustable weirs at its larger end for discharge of clarified effluent, commonly called the centrate, and (d) solids discharge ports on the opposite end for discharging the dewatered solids, simply called cake. As the bowl rotates, centrifugal force causes the sludge slurry to form an annular pool. The pool depth is determined by the adjustment of the effluent weirs. A portion of the bowl diameter is reduced and not submerged in the pool, forming a (f) drainage deck for dewatering the solids as they

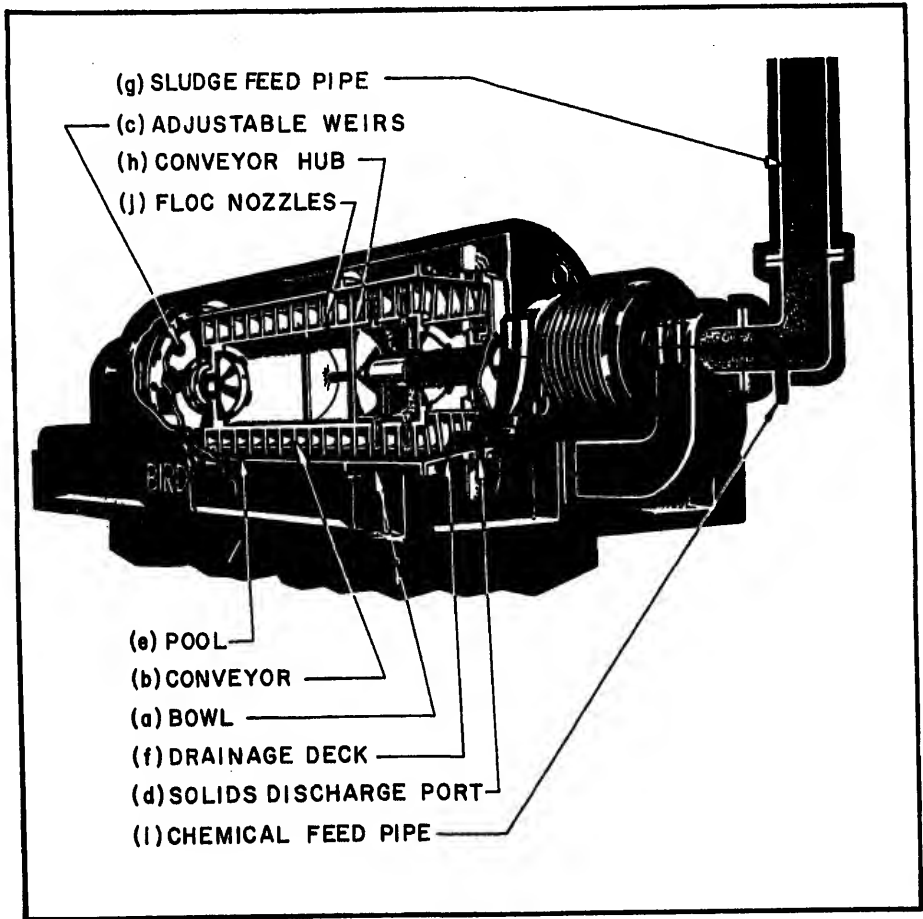

Fig. 8 - Bird Solid Bowl Continuous Centrifuge With Countercurrent Flow.

Courtesy of Bird Machine Company, South Walpole, Mass.

are conveyed across it. The bowl and conveyor rotate in the same direction, with the conveyor speed approximately 99 per cent of the bowl speed, depending upon the particular gear unit ratio employed.

Sludge fed into the centrifuge enters through a stationary (g) supply pipe and passes through the (h) conveyor hub into the bowl itself. As the solids settle out in the bowl, due to centrifugal force, they are picked up by the conveyor and carried along continuously to the solids outlet; meanwhile, the clarified effluent continuously overflows the effluent weirs.

If chemical treatment is required to flocculate fine suspended solids, the chemical solution can be introduced into the centrifuge through a (i) separate chemical feed pipe, then through the conveyor hub into the pool by means of (j) floc nozzles projecting beneath the liquid pool surface in the settling zone. Thus the floc nozzles gently mix the chemical solution with the liquid pool by means of the differential rotating speed between the conveyor and the bowl.

Concurrent flow solid bowl centrifuge - The cut-away drawing in Figure 9 shows the operating principles of the new Bird concurrent flow centrifuge. The two most important differences between the concurrent flow centrifuge and the countercurrent flow centrifuge are: (1) the point of introducing sludge slurry into the bowl and (2) the method of discharging the clarified effluent.

Sludge fed into the (a) rotating bowl of a concurrent flow centrifuge is discharged through the (h) conveyor hub ahead of the settling zone. Settled solids are carried along by the (b) conveyor in the same

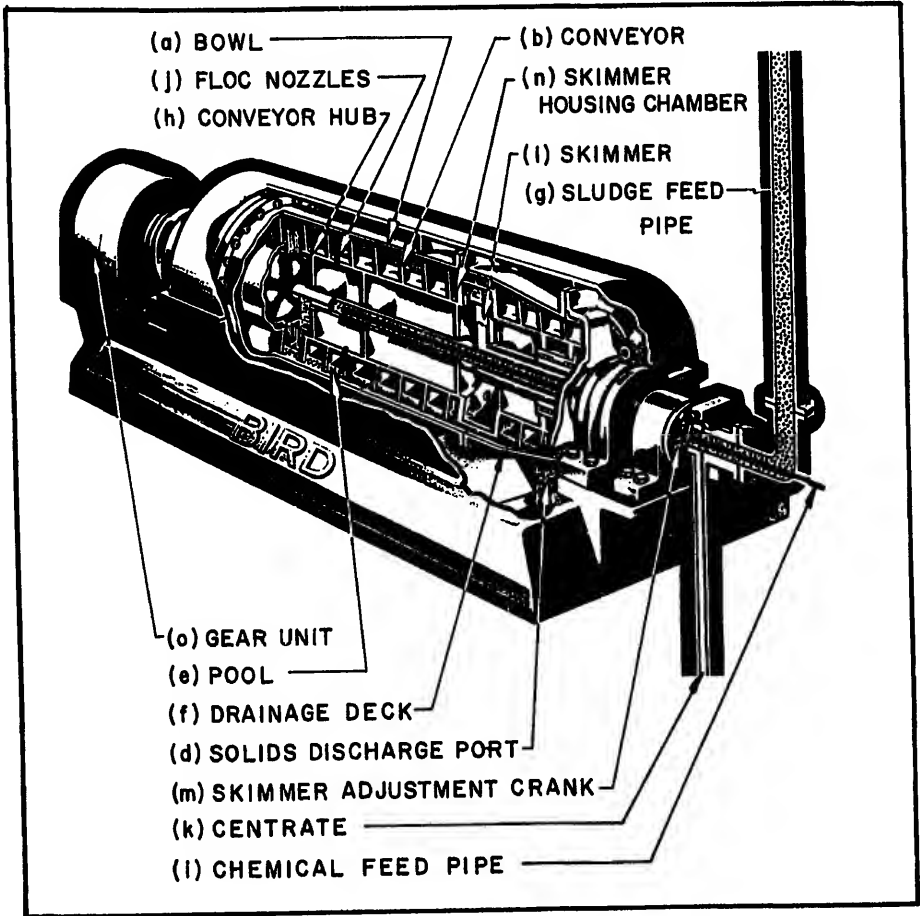

Fig. 9 - Bird Solid Bowl Continuous Centrifuge With Concurrent Flow.

Courtesy of Bird Machine Company, South Walpole, Mass.

direction as the liquid, hence the flow pattern through the bowl is smooth. Settled solids are conveyed over the entire length of the bowl and they are not disturbed by incoming feed or turbulence caused by the countercurrent flow.

Clarified (k) concentrate is discharged under pressure by a (l) skimmer which is adjustable to regulate the pool depth. Adjustment is by an external (m) hand crank and can be made while the machine is operating. The skimmer is housed in a (n) chamber to confine any turbulence that might disturb the settled solids.

If chemical treatment is required it is done in the same manner as described for the countercurrent machine. The chemical solution is gently mixed with the liquid pool as a result of the differential rotation between the conveyor and the bowl.

Pilot Plant Equipment

The pilot plant for dewatering sewage sludges was located at the Phelps Laboratory for Environmental Research at the University of Florida. The site was located adjacent to the campus sewage treatment plant from which raw, activated, and digested sludges were obtained for experimental purposes. The schematic flow diagram for the sludge dewatering pilot plant is shown in Figure 10.

The equipment list for the pilot plant included the following major pieces of equipment: a Bird 6 x 12 inch solid bowl centrifuge, positive displacement sludge feed and chemical dosing pumps, sludge holding tanks with stirring mechanisms, and metering devices for measuring the rate of polymer addition.

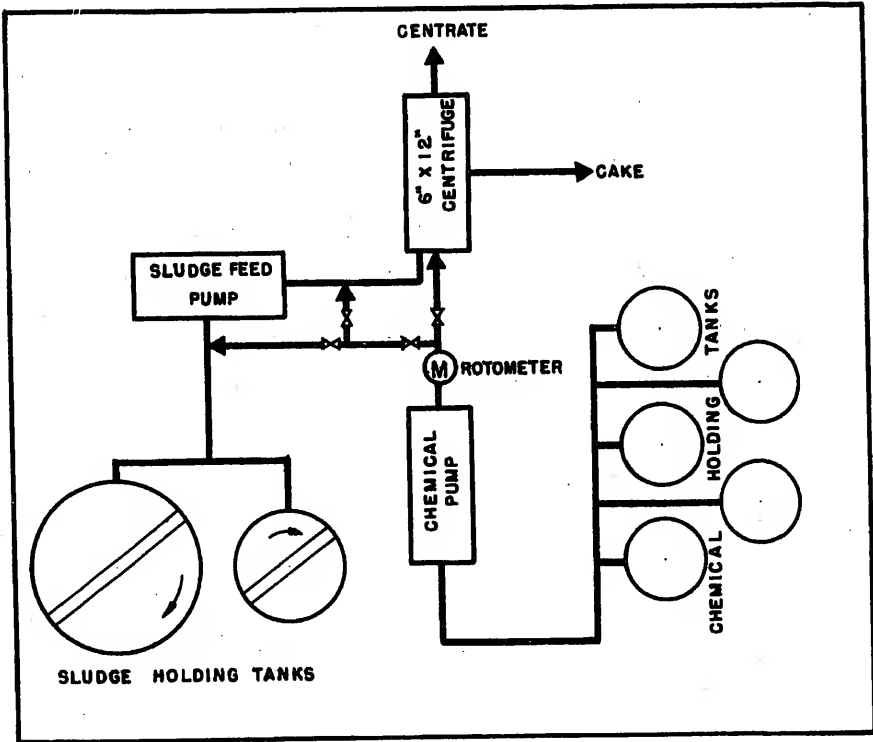

Fig. 10 - Schematic Flow Diagram of Sludge Dewatering Pilot Plant, University of Florida.

Bird 6 x 12 inch centrifuge - The 6 x 12 inch solid bowl centrifuge with countercurrent flow is illustrated in Figure 11. The 6 inch machine was driven by a 5 horsepower (hp) 3,600 revolutions per minute (rpm) explosion-proof AC motor, belted to the machine. Prebalanced drive sheaves were used to obtain constant speeds of 2,830, 3,750, and 5,810 rpm. The relative centrifugal force (R.C.F.) developed within the bowl at these three respective speeds was 680, 1,180, and 2,880 times the force of gravity. The gear unit ration, 100:1, fixed the differential rotation between the bowl and conveyor.

The pool depth was adjusted by means of twelve effluent ports made up of four equally spaced holes on each of three different radii. Three sets of different diameter bushings were available (3/8, 1/2, 5/8 inch diameter), but only the 1/2 inch bushing was used in these tests since it was representative of the deepest and shallowest available pool depths. The 1/2 inch bushings were placed in corresponding holes 90 degrees apart around the face of the bowl head. The remaining holes were plugged with cap screws.

Sludge feed pump - The sludge feed pump was a new Moyno* Model 1L4, I Frame, Type CDQ pump having a cast iron inlet housing a hardened tool steel chrome plated rotor, and a synthetic Buna "N" rubber stator. The pump discharge range was from 1 gpm to 10 gpm. The pump was driven by a 1/2 hp U.S. Varidrive,** Type VAV-HV-GR, Frame No. 6-56-5. The positive displacement pumping action provided by the Moyno supplied a

* Manufactured by Robbins and Meyers, Inc., Moyno Pump Division, Springfield, Ohio.

** Manufactured by U.S. Electrical Motors, Los Angeles, Calif.

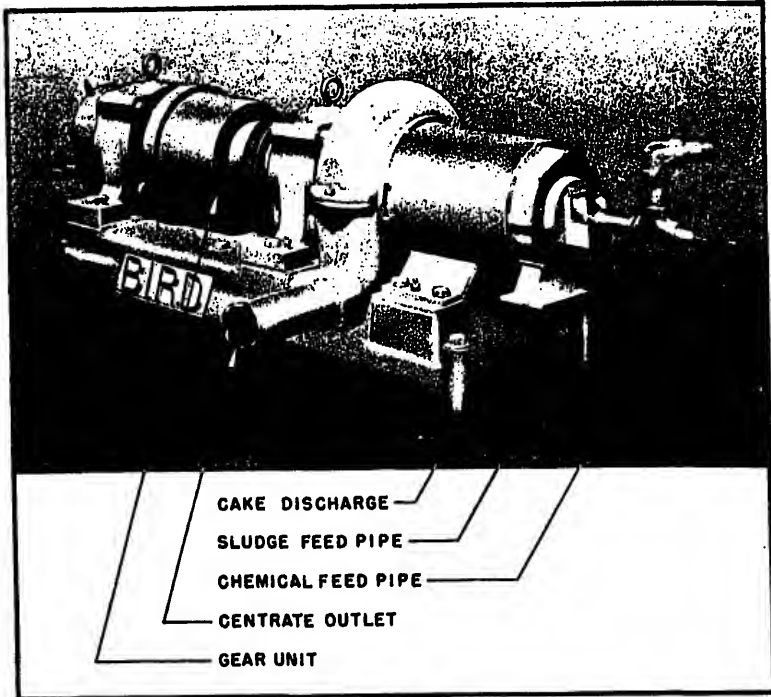

Fig. 11 - Bird 6x12 Inch Solid Bowl Continuous Centrifuge.

Courtesy of Bird Machine Company, South Walpole, Mass.

continuous discharge of sludge to the centrifuge without pulsation. Since the volumetric displacement of sludge for each rotor revolution was affected only slightly by changes in discharge pressure, metering of the flow rates was exceptionally accurate. The variable speed drive provided a convenient and reproducible means of changing the sludge feed rate.

Polymer dosing pump - The pump used most frequently for adding polyelectrolytes to the sludge was a completely rebuilt Moyno Model 1L2, L Frame, Type CDQ pump constructed as described before. The pump discharge range was from 0.070 gpm to 0.70 gpm and was driven by a U.S. Varidrive, Type VAV-HV-GR and Frame No. 6-56-5 with a 1/4 hp motor.

Rotameters - The polymer dosing rate was continuously monitored by rotameters. The rotameters employed were:

- 1 - Flowrator,* Model 10A1027A, Serial 6706A5623A1, maximum rate 0.425 gpm.
- 1 - Flowrator, Model 10A1027A, Serial 6706A5623A5, maximum rate 0.810 gpm.

Sludge holding tanks - Sludge from the University of Florida Sewage Treatment Plant was trucked to holding tanks at the pilot plant. The tank capacities were 200 and 1,500 gallons respectively, each with motor driven stirring paddles and baffle arrangements to insure thorough agitation during the holding period and therefore providing a uniform sludge concentration throughout the tank. The rotational speed of the stirring paddles

*Manufactured by Fischer and Porter Company, Warminster, Pa.

was 100 rpm.

Equipment Used at Treasure Island, Florida

The pilot plant sludge dewatering equipment was truck-mounted and transported to Treasure Island so that experiments could be conducted with the Bird 6 x 12 inch centrifuge on the same sludges being dewatered by the 24 x 38 inch centrifuge installed at the Treasure Island Water Pollution Control Plant.

Bird 24 x 38 inch centrifuge - The 24 x 38 inch solid bowl continuous centrifuge with countercurrent flow was equipped with a bowl having a three degree cylindrical section and a ten degree conical drying deck. The gear ratio was 140:1. The centrifuge was driven by a 40 hp, 1,800 rpm motor and the bowl rotated at a constant rotational speed of 2,000 rpm. The relative centrifugal force produced at this rotational speed was 1,335 times the force of gravity. The centrifuge was constructed and operated as illustrated in Figure 8.

Sludge feed pump - Raw and digested sludges were pumped to the centrifuge with a Moyno Model 1L8, Type CDQ with a discharge range from 9 gpm to 90 gpm. The pump was driven by a U. S. Varidrive, Type VAV-HV-GR, with a 1 1/2 hp motor.

Waste activated sludge was supplied by gravity to the centrifuge by means of a splitter head box in the return sludge line, located 3 1/2 feet above the inlet to the centrifuge.

Polymer dosing pump - The polymer dosing range was between 0.5 to 10 gallons per minute. To provide for such a wide pumping range, a F&W

Water Systems* jet pump, Serial Number F65, was used. The pump was driven by a 3/4 hp motor and provided a steady uniform discharge over a wide range of discharge heads and suction lifts. A pump of this kind was ideal for the testing program.

Rotameters - The rotameters used were:

- 1 - Flowrator, Model 10A1027A, Serial 6706A5623A3, maximum flow 2.7 gpm.
- 1 - Flowrator, Model 10A1027A, Serial 6706A5623A4, maximum flow 10 gpm.

Equipment Used at St. Petersburg, Florida

The pilot plant sludge dewatering equipment was also transported to this plant. Experiments were conducted with the Bird 6 x 12 inch centrifuge on the same sludges being dewatered with a new 24 x 60 inch Bird centrifuge installed at the Northeast Sewage Treatment Plant.

Bird 24 x 60 inch centrifuge - The Bird 24 x 60 inch solid bowl continuous centrifuge was driven by a 75 hp, 1,800 rpm motor. Bowl rotational speeds of 1,520 rpm, 2,000 rpm, and 2,400 rpm were obtained by three sheave sizes. The relative centrifugal force was respectively 850, 1,350, and 1,950 times the force of gravity. The gear ratio was 140:1. A full range of pool depths from a very shallow to a very deep pool was readily obtainable by exterior adjustment of the effluent skimmer. The machine was constructed as shown in Figure 9 and operated as previously described.

* Manufactured by Flint and Walling, Kendallville, Indiana.

Sludge feed pump - The sludge feed pump was a Moyno Pump, Frame SW12H, with a rated discharge capacity of 175 gpm to 275 gpm. The pump was driven by a U.S. Varidrive operating over a range of 35 rpm to 350 rpm, thus the actual pump discharge range was from 23 to 230 gpm.

Polymer dosing pump - The F&W Water Systems jet pump as previously described was used.

Rotameters - A Flowrator Model 10A1027A, Serial 6706A5623A4 with a maximum flow rate of 10 gpm was used.

Materials

Domestic Waste Sludges

The sludges dewatered by centrifuges in this study were obtained directly from processing units at each sewage treatment plant where the experiments were conducted.

Prior to centrifuging any sludge in the 6 x 12 inch machine, it was necessary to screen it through hardware mesh with 1/4 inch openings. If the sludge was not screened, the 3/4 inch diameter feed pipe and the accelerator within the conveyor hub were quickly plugged. Screening did not decrease the suspended solids of the return activated sludge; however, screening of the digested sludge reduced the suspended solids approximately 10 per cent on a dry weight basis. Those items retained on the 1/4 inch screen would have been readily settled in the centrifuge and would not have exerted a chemical demand; however, they would have given the dewatered sludge a more fibrous consistency. Screening had the greatest effect on raw sludge, reducing the solids concentration of the raw sludge by 50 per cent. This was attributed to the fibrous consistency of the

sludge which quickly covered the openings and acted as a fine screen. Sludges dewatered in the 24 x 38 inch and 24 x 60 inch centrifuges were not screened, but were pumped directly from the process unit to the centrifuge.

Since every plant has a different character of sewage and sludge to be dewatered, it is difficult to point out average or exceptional sludge characteristics; therefore, a description of each plant included in this study is presented.

University of Florida Sewage Treatment Plant

Located on the campus, the sewage treatment plant has a capacity of two million gallons per day and is designed primarily as a research facility. The University Plant has three types of treatment, including standard and high-rate filtration and activated sludge treatment. The digested sludge used in the experiments was a mixture of raw, trickling filter and waste activated sludges digested anaerobically in open, unheated digesters. The return activated sludge used was bulky and had a sludge volume index exceeding 200. The raw sludge consisted of raw settled sewage and any digested sludge that settled from the digester supernatant returned to the plant influent. Since completion of this study the campus plant is undergoing an expansion program and substitution of contact stabilization for the activated sludge process. Therefore, no schematic flow sheet for this treatment plant is included.

Water Pollution Control Plant, Treasure Island, Florida

This plant is located in the center of town and is surrounded by high-rise hotels, commercial establishments, and expensive homes; it has

a capacity of 1.5 million gallons per day. A schematic flow sheet of the Treasure Island Plant is presented in Figure 12. The method of waste water treatment at this plant is the contact stabilization process,¹⁷ preceded by primary sedimentation. Raw, activated return, and anaerobically digested sludges were dewatered at this plant with the 6 x 12 inch and/or 24 x 38 inch centrifuges. The plant has used a 24 x 38 inch Bird centrifuge in a dual capacity since 1965 to concentrate waste activated sludge every other day for three to five hours and to dewater digested sludge six to ten hours per month. The operation of the centrifuge at this unique plant has frequently been presented by others.^{13,28,30}

Northeast Treatment Plant, St. Petersburg, Florida

This plant treats five million gallons per day by means of the high rate activated aeration process.⁷³ A schematic flow sheet of the treatment plant is shown in Figure 13. Approximately 30,000 gallons of waste sludge (2.5 per cent suspended solids) are generated per day. The sludge used in the experiments was characteristically bulky, black and septic.

The circumstances surrounding the installation of the 24 x 60 inch centrifuge are important to understanding the experiments conducted at this plant.

The City of St. Petersburg purchased two Bird 24 x 60 inch solid bowl centrifuges with concurrent flow for installation at the Albert Whitton Sewage Treatment Plant. The plant was then undergoing expansion and modification to provide secondary treatment of waste water for the southeast section of the city. Meanwhile, the Northeast Sewage Treatment

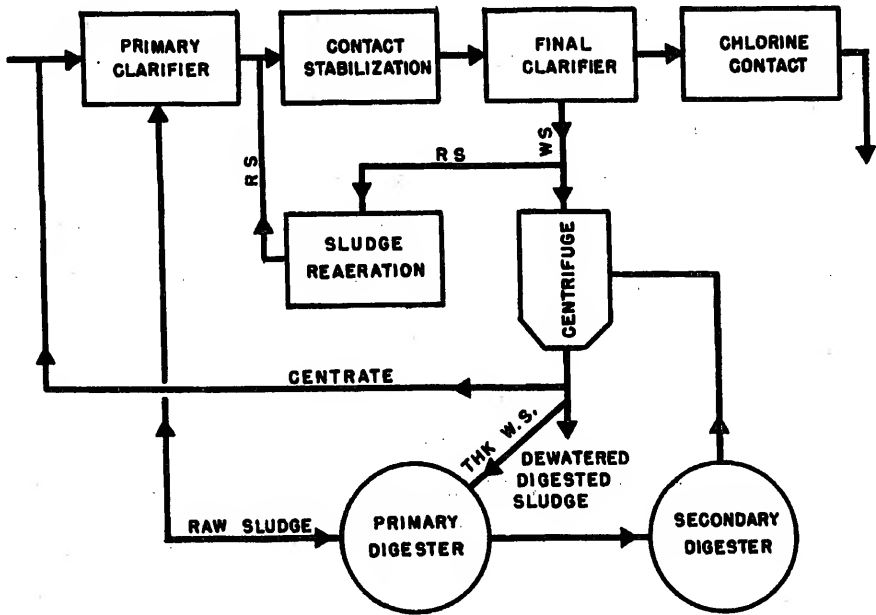

Fig. 12 - Flowchart of the Modified Contact Stabilization Process at the Water Pollution Control Plant, Treasure Island, Florida

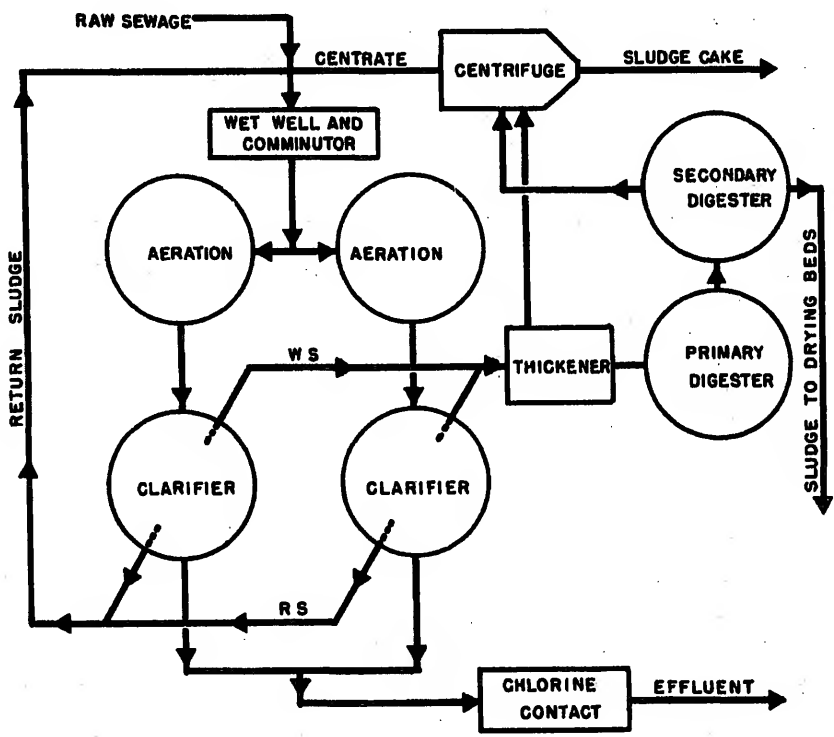

Fig. 13 - Schematic Flow Diagram of the Northeast Sewage Treatment Plant, St. Petersburg, Fla.

developed an acute excess sludge problem. As a means of resolving the problem, it was decided to divert one of the two centrifuges which were to be installed at the Albert Whitted Plant to the Northeast Plant. A crash program was instigated in July, 1967, to install and operate one of the 24 x 60 inch centrifuges at the Northeast Plant. The centrifuge was to thicken waste sludge before pumping it to the digester and dewater the digested sludge. Bird Machine Company conducted the start-up testing program in which the author participated.

Polyelectrolytes

The polyelectrolytes included in laboratory and centrifugation tests in this study are listed in Table 2. Purifloc C-31, Primafluc C-7, and CAT-FLOC were selected for extensive use in this study because they consistently gave the best results. Their effectiveness, compared to each other on an equal cost basis, was nearly the same. Purifloc C-31 and Primafluc C-7 are currently used extensively in wastewater treatment and sludge dewatering; therefore, the results of this study can be compared with work done by others. CAT-FLOC is a new polymer recently released for sale, although many years of research and testing have gone into its development. Research conducted at the University of Florida has found CAT-FLOC to be an extremely effective polymer for turbidity removal in water treatment and for solids-liquid separation in sewage treatment.^{73,74} Another factor which influenced the selection of this polymer was that Calgon Corporation had developed a colorimetric test for detecting CAT-FLOC concentrations as low as 3 to 5 mg/l in water.⁷⁵

CAT-FLOC is a high molecular weight, linear homopolymer of diallyl-dimethylammonium chloride. The linear chain has recurring N-substituted

Table 2
Polyelectrolytes Used in Laboratory Tests

Manufacturer	Polyelectrolyte	Ionic Character
Calgon Corporation Pittsburgh, Pa.	CAT-FLOC*	Cationic
Rohm and Haas Philadelphia, Pa.	Primaflow C-7	Cationic
The Dow Chemical Co. Midland, Mich.	Purifloc C-31 Purifloc A-21 Purifloc 1193 Purifloc SA11861 Separan NP-20	Cationic Anionic Anionic Cationic Nonionic
Hercules Incorporated Wilmington, Delaware	Reten 210	Cationic
Nalco Chemical Co. Chicago, Illinois	Nalco 600	Cationic

*Code P-112-C-10.

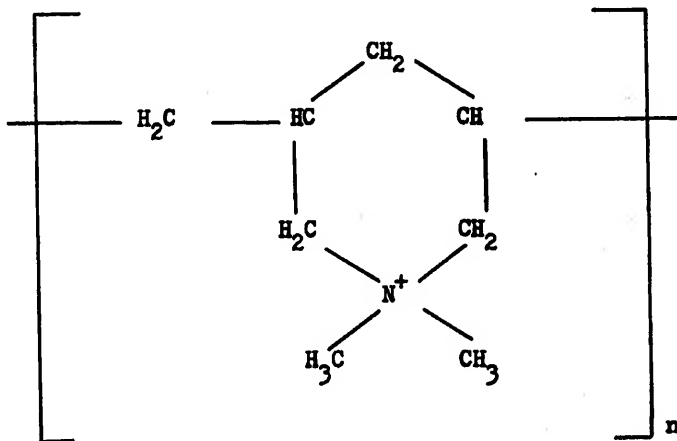

Fig. 14 - Recurring Molecular Unit of Ionized CAT-FLOC.

piperidinium halide units alternating with methylene groups. The ionized form of the CAT-FLOC (cationic polymer) molecule is shown in Figure 12.⁷⁴

Purifloc C-31 and Primafluc C-7 are polyamines of high molecular weight and when ionized are cationic. Since these polymers are marketed as proprietary chemicals, their chemical components and molecular configurations are not described to the trade and only generalized descriptions can be applied to them.

Procedures

Sludge Preparation

Sludge to be used in the pilot plant required collection and storage of a sufficient volume to insure completion of the experiment. The sludge was screened at its point of collection and transported to the pilot plant. It was then transferred to the holding tanks and stirred to

insure homogeneous concentration. Three 500 ml samples were collected for analyses of the initial sludge properties. A 500 ml sample of the unscreened sludge was obtained to determine the suspended solids concentration prior to screening.

No special sludge preparation was necessary prior to operating the two 24 inch centrifuges. Sludge was pumped directly from the process unit into the centrifuge. The sludge was sampled three different times during the day prior to the start of the test to get the approximate sludge concentration that could be expected during centrifugation. This enabled chemical solutions to be prepared in the desired range of dosages.

Determinations on Feed Sludge, Centrate, and Cake

The following determinations were made on the initial properties of the sludge, centrate, and cake when applicable: total solids, suspended solids, volatile suspended solids, alkalinity, pH, electrophoretic mobility, streaming current, sludge volume index, specific gravity, temperature, and residual CAT-FLOC. The respective determinations were made as follows:

Total solids - Total solids determinations were made on the initial feed sludge and cake in accordance with Standard Methods, Part III A, Residue on Evaporation.⁷⁶

Total suspended solids - Total suspended solids determinations were made on the initial feed sludge and on the centrate. When the concentration of the suspended solids in the feed sludge or centrate was estimated to be greater than one per cent, the total suspended solids determinations were made by filtering a 100 ml sample through a previously numbered, dried (at 103°C for six hours) and weighed 15 cm Whatman No. 1 filter

paper in an 11 cm Buchner funnel prevented loss of solids around the edge of the filter. The filters used were dried at 103°C for 24 hours, cooled to weighing room temperature in a desiccator, and reweighed on a single pan automatic balance.* The long drying time was necessary because of the large number of samples being dried simultaneously during a series of test runs.

When the sludge or centrate suspended solids concentration was estimated to be less than 1 per cent, the total suspended solids determinations were made by filtering a 50 ml sample through a previously prepared, dried and weighed Gooch crucible, containing a fiber glass filter** (Reeve Angel 934-AH). The crucibles were dried at 103°C for 24 hours, cooled to weighing room temperature, and reweighed on the automatic balance. The Gooch crucibles containing a 2.4 cm glass filter were prepared by filtering 100 ml of demineralized water through the filter, drying at 103°C for six hours, cooling to weighing room temperature in a desiccator, then weighing on the automatic balance. The glass fiber filter was selected for use since it is superior to and much more convenient than the old asbestos mat technique.^{77,78,79}

Volatile suspended solids - Volatile suspended solids determinations were made on some of the suspended solids samples taken of the sludge and centrate in accordance with Standard Methods, Part III D.⁷⁶

The total alkalinity of the feed sludge was determined in accordance with Standard Methods, Parts III and IV.⁷⁶ The total alkalinity is

*Product of August Sauter of New York, Inc., Albartson, New York.

**Product of Reeve Angel, Clifton, New Jersey.

expressed as mg/l CaCO₃.

Measurement of pH - All pH measurements were made with a Beckman Model G pH Meter.*

Electrophoretic mobility - Electrophoretic mobility determinations were made by using a Zeta-Meter.** in accordance with the Zeta-Meter Manual.⁶⁷ The procedure for making a determination of the mobility of feed sludge or centrate sample was as follows. An 11 cm Whatman No. 1 filter paper was prepared by filtering approximately 100 ml of distilled water through it and discarding the filtrate. Next, approximately 50 ml sample of filtered and about 10 ml of filtrate was diluted to 100 ml with distilled water for use in the apparatus. Experience has shown that filtering the sample does not materially alter the electrophoretic mobility of the sample.⁷⁹ The Zeta-Meter cell was washed with distilled water and pipe stem cleaners followed by rinsing the cell with the filtrate of the sample. The cell was then carefully filled with the filtrate to avoid bubble formation. Twenty individual particle mobilities, ten in either direction, were used to obtain an average particle mobility for each sample. The calculated mobilities are time-averaged rather than velocity-averaged mobilities.

Streaming current - Streaming current determinations were made by using a Streaming Current Detector*** in accordance with the Streaming

*Manufactured by Beckman Instruments, Inc., Fullerton, Calif.

** An instrument manufactured by Zeta-Meter, Inc., New York, N. Y.

*** An instrument manufactured by Waters Associates, Inc., Framingham, Mass.

Current Detector Instruction Manual.⁸⁰ The procedure for making a determination of the SCD instrument reading of a feed sludge or centrate sample was as follows. The boat and piston of the instrument were scrubbed with Lava soap and rinsed thoroughly with distilled water. Then the boat and piston were washed with the sample itself. The reservoir boat was then filled with the unfiltered sample and the SCD reading observed on the 10X linear scale recorded. The boat was emptied and refilled with additional aliquots of the same sample and the SCD read until two consecutive instrument readings were within ± 2 microamperes. Usually three determinations were necessary for each sample.

Sludge volume index - The sludge volume index (SVI) determinations for activated sludges were made according to Standard Methods, Part V C.⁷⁶

Specific gravity - Specific gravity determinations were accomplished in accordance with Standard Methods, Part V.⁷⁶

Temperature - The temperature of the sludge was determined in the holding tank prior to centrifugation by means of a bulb partial immersion thermometer with a range of -30 to 120°F.

Residual polymer - Residual CAT-FLOC polymer determinations were made according to a procedure developed by Calgon Corporation.⁷⁵ The test originally developed for Polymer 261 is applicable for CAT-FLOC detection because its properties are similar to type 261. The test is based on reduction in color intensity of indigo carmine in an alkaline medium. According to Kleber,⁸¹ the test might be useful in connection with the dewatering of sludge, but he notes that other nitrogen compounds in sewage may interfere. Compounds known to interfere in the test for Polymer 261 are: chelating agents such as Calgon and EDTA which cause low

results in the test. High concentrations of Mg produce a turbidity due to the precipitation of magnesium hydroxide.

Residual CAT-FLOC was determined in only a portion of the concentrate samples. Samples were prepared by filtering at least 150 ml of the concentrate through a 0.45 HAWP Millipore Filter.* Determinations were made by the procedure outlined by Calgon Corporation with the following modification. The absorbance value for the buffered sample was subtracted from the sample with indigo carmine and buffer to correct for sample color and turbidity.

Laboratory Dewatering Tests

A part or all of the following laboratory tests were conducted on the sludge prior to centrifuging to estimate the most effective polymer, polymer dosage, and dewatering characteristics of the sludge. The respective laboratory tests were made as follows.

Polymer flocculation - Three 250 ml graduated cylinders were filled with sludge, the desired polymer dosages, from stock solutions, and diluted to 25 ml with distilled water. The respective polymer dosages were added to a cylinder and the cylinders inverted four times. The following was observed: (1) rate of floc formation; (2) degree of separation into distinct agglomerated flocs and clear liquor; and (3) the degree of compaction upon settling measured by the sludge depth after three minutes.

Buchner funnel - The specific resistance of the sludge was determined by the Buchner funnel test. The test was accomplished in accordance with the technique recommended by Parsons.⁸² An 11 cm Whatman No. 41 filter paper was placed in a Buchner funnel, moistened, and set in place

*A product of Millipore Corporation, Bedford, Massachusetts.

by applying a vacuum for a few seconds. The desired polymer dosage was diluted to a volume of 50 ml and added to 200 ml of sludge in a 250 ml graduated cylinder. The polymer and sludge were then mixed by inverting the cylinder four times. The polymer conditioned sludge was poured into the Buchner funnel and after approximately five seconds for sludge cake formation, a 20 inch mercury vacuum was applied to the filter. The filtrate was collected in a 250 ml graduated cylinder and its volume was recorded at 30 second intervals from 0 to 270 seconds. This procedure was repeated for at least four polymer dosages. The specific resistance was then calculated from the data by the well-known method presented by Eckenfelder and O'Connor.⁸³

Laboratory centrifuge - Thirty ml aliquots of sludge were placed in 50 ml beakers. The desired polymer dosage was diluted to 10 ml and added to the sludge. The beaker was inverted four times to mix the polymer and the sludge and then poured into a 40 ml graduated, heavy duty centrifuge tube (Kimax Brand, Serial 45404). Four chemical dosages were prepared at a single time and then centrifuged in an International Centrifuge,* Size 1, Model SBV 12440. The samples were accelerated as rapidly as possible to a speed equivalent to the relative centrifugal force to be used in the solid bowl centrifuge. The sample was spun for 22 seconds (the approximate detention time in the Bird 6 x 12 inch centrifuge at a deep pool and a 1 gpm sludge feed rate) and braked to a rapid stop. The

*Manufactured by the International Equipment Company, Boston, Massachusetts.

relative clarity of the supernatant and its depth were noted between the different dosages. The solidity of the cake was estimated by probing it with a 1/16 inch diameter glass stirring rod.

Experimental Design and Evaluation

The experiments conducted in this study were arranged according to an ordered plan in which all the factors were varied in a systematic way. It was thus possible to determine the main effect of each individual factor and the interactions. The experimental designs were of the randomized block, split-plot, and split-split-plot types, with two replications made of each treatment combination.^{84,85} The essential feature of the split-plot experiment is that the sub-plot treatments are not randomized over the whole block but only over the main plots. Randomization of the sub-treatments is different (characteristically smaller) than that for the main treatments. The randomization was accomplished by using a table of randomly assorted digits.⁸⁴

The analysis of variance for each experiment was calculated by the IBM 360 computer at the University of Florida Computing Center. The computer program calculated the analysis of variance table by the modified Kronecker product method. The program was written by Sara Kephart, Programmer, University of Florida Computing Center, and is maintained and available for use in the Center's library. The program solution assumes that the contrasts are mutually orthogonal. A maximum of seven factors is allowed and 15 responses can be run at one pass. The user has the

option of either individual degrees of freedom printed out or just the total of all degrees of freedom for the particular source of variation. The program output provides, in any order specified by the user, each source of variation along with the degrees of freedom, the sum of squares, the mean square, and if individual degrees of freedom are required, the matrix vector product and its divisor.

In the analysis of variance table the significance of the effects was tested by the F-ratio, where the mean square for the effect was divided by the mean square for error, and the result compared with tabulated F distribution values.⁸⁴

Experimental Procedures

The tests were conducted carefully to reduce the experimental error. Approximately two months of operating experience was necessary to become familiar with the centrifuging procedures, to work out the experimental procedures and analytical tests, and to improve the mechanical equipment in support of the project.

Polymer preparation - Polymer dosage is defined as pounds of polymer (liquid or solid) as received from the manufacturer per ton of dry suspended solids in the feed sludge, as opposed to polymer dosing rate which is defined as the volumetric rate of adding a polymer solution to a sludge. Polymer solutions of desired concentration were prepared in sufficient volume so that they could be added directly to the sludge or within the centrifuge without further dilution. This method, although impractical on a full scale operational basis (in most cases), was ideal for testing purposes since it eliminated another source of experimental

error. This procedure was used for all tests in this study except for the final ones conducted on return sludge at the Northeast Plant in St. Petersburg, Florida. At that time the chemical pumps and dilution water arrangement for the 24 x 60 inch centrifuge had been installed and were operational.

Order of test runs - The order of the test runs was randomized according to the particular statistical design of the experiment and recorded on data sheets as shown in Table 3.

Calibration of pumps - Before starting the test runs the sludge feed and polymer dosing pumps were calibrated. The sludge pumps were calibrated by measuring the volume of their discharge over a period of two minutes. The variable speed drive setting was marked when the desired discharge rate was obtained. Consistently reproducible results were obtained by this technique.

Polymer dosing rates were determined by measuring the solution draw-down rate in the polymer holding tank or collecting the discharged volume over an interval of two minutes. The rotameters installed in the polymer discharge line were calibrated simultaneously for each solution to be used.

Establishing equilibrium - The time required for establishing equilibrium within the centrifuge depended upon the size of the machine. Equilibrium can be defined as that condition when the centrate and cake being discharged from the centrifuge are consistently the same for the existing conditions of the test run. The time required to reach equilibrium is much greater than the flow through time. Time to reach

Table 3

Data Sheet

Test No. _____
Centrifuge _____

Date _____
Location _____

<u>Run No.</u>						
<u>Type of sludge</u>						
<u>Feed rate, SPM</u>						
<u>Lbs/min</u>						
<u>% Solids in feed, TS</u>						
<u>SS</u>						
<u>VSS</u>						
<u>% Solids in centrate, TS</u>						
<u>SS</u>						
<u>VSS</u>						
<u>% Solids in Cake, TS</u>						
<u>VS</u>						
<u>% Recovery</u>						
<u>Name chemical added</u>						
<u>Location chem, added</u>						
<u>Rate chem, added, gpm</u>						
<u>Chem, dosage, lbs/ton</u>						
<u>Dilution water, gpm</u>						
<u>R.C.F., x gravity</u>						
<u>Pool depth</u>						
<u>Gear Ratio</u>						
<u>Amps</u>						
<u>Feed/centrate pH</u>						
<u>Alk.</u>						
<u>SVI</u>						
<u>Temp.</u>						

equilibrium in the three machines used was: (1) 4 minutes for the 6 x 12 inch centrifuge; (2) 10 minutes for the 24 x 38 inch centrifuge; and (3) 15 minutes for the 24 x 60 inch centrifuge. The cake and centrate were sampled after equilibrium had been established. A stop watch as well as visual inspection were used to determine when equilibrium had been attained.

Sampling the centrate - The centrate was sampled by a volumetric technique. If the centrate contained a high percentage of suspended solids, a 100 ml volume sample was collected directly in a 100 ml graduated cylinder; otherwise a 50 ml graduated cylinder was used. The cylinder was rapidly passed back and forth through the centrate stream over a period of 30 seconds. The suspended solids analysis was completed immediately on the volumetric centrate sample. Centrate samples collected in containers and analyzed at a later time were in error by as much as 10 to 20 per cent in some cases, because the suspended solids agglomerated and stuck to the sides of the container, thus rendering the sample non-representative.

A second sample of the centrate was collected in a liter jar and was used for residual polymer, electrophoretic mobility, and streaming current determinations as soon as the centrifuge test runs were completed.

Sampling the sludge cake - A sludge cake sample of approximately four ounces was collected in a paper cup. The total solids analysis was accomplished immediately by transferring a portion of the cake to a tared dish, weighing the wet cake, and then drying it at 103°C. Cake samples collected in sample jars and stored for analysis later were found to be

in error from 5 to 10 per cent because water continued to be expelled from the cake by action of the polymer.

Data Recording and Calculations

The centrate and cake samples, crucible, filter, and dish numbers and calculations were recorded on the Calculation Sheet shown in Table 4. Suspended solids concentration in the centrate samples was corrected for the volume of polymer solution added by assuming that the liquid valence is discharged as centrate. This corrected value for solids in centrate was used in calculating the recovery of suspended solids.

The per cent recovery of suspended solids from the feed was calculated by the following formula:

$$\text{Recovery, \%} = 100 - \frac{\frac{100}{\% \text{ Solids in Feed}} - \frac{100}{\% \text{ Solids in Cake}}}{\frac{100}{\% \text{ Solids in Cen-}} - \frac{100}{\% \text{ Solids in Cake}}} \times 100$$

trate

This formula, derived from a materials balance, corrected the per cent recovery for the moisture content of the cake.

Table 4

Calculation Sheet

Run No. _____

Sample No. _____

Centrate Crucible No. _____

Sample Volume, ml _____

Dry SS + Tare _____

Tare Weight _____

SS mg/l _____

SS Weight _____

% SS in Centrate _____

SS Ash + Tare _____

Tare Weight _____

% Ash SS = _____ x 100 = _____

SS Ash Weight _____

% VSS = _____

Cake Dish No. _____

Wet Cake + Tare _____

Dry Cake + Tare _____

Tare Weight _____

Tare Weight _____

Wet Cake Weight _____

Dry Cake Weight _____

Ash Weight + Tare _____

% TS Cake = _____ x 100 = _____

Tare Weight _____

% Ash Cake = _____ x 100 = _____

Ash Weight _____

% VS = _____

Feed Filter No. _____

Sample Volume, ml _____

Dry TS + Tare _____

Dry SS + Tare _____

Tare Weight _____

Tare Weight _____

TS Weight _____

SS Weight _____

% Recovery *

CHAPTER V
RESULTS AND DISCUSSION

Introduction

The data and analysis of variance for each experiment in this study are tabulated in Appendix 1. A glossary of terms used in this study is presented in Appendix 2. Results of centrifugal dewatering of domestic waste sludges are presented in the following order: anaerobically digested sludge; activated sludge; and raw sludge.

In this research the effects of machine and process variables on dewatering domestic waste sludges were evaluated. These were centrifugal force, pool depth, sludge feed rate, sludge concentration, polymer, polymer dosage, and location of polymer addition.

The split-plot and split-split-plot designs⁸⁴⁻⁸⁶ for the factorial experiments were chosen for practical reasons related to time and effort required in changing the machine speed and pool depth. The experiment became too large if more than three variables were evaluated at three levels. Therefore, the approach was a systematic investigation of two or three machine and/or process variables at a time. Each treatment combination was applied twice, that is, treatments were replicated two times. The replicates were established as blocks since the sludge dewatering properties were likely to be more homogeneous within each set of replications than over the whole experiment. The block error can be attributed to changes in the sludge characteristics over the length of

time to complete the experiment.

The significance of the effects was tested by the F ratio.⁸⁴ The asterisks in the analysis of variance tables indicate the probability that such a result would be obtained if the distribution of the parent populations were the same.

Dewatering Digested Sludge

The results of experiments conducted on digested sludge are shown in Figures 15 through 24. For ease and clarity of understanding the objective of each experiment, the variables investigated and the responses observed are shown in Table 5. Experiments 1 through 4 were conducted with the same sludge sample (1,500 gallons).

Experiment 1

The first experiment evaluated the effect of the sludge feed rate, polymer dosage, and location of polymer addition. The experimental design was a split-plot with two replicates made of each treatment combination.

Results - The analysis of variance for this experiment indicates highly significant two and three factor interactions between feed rate, polymer dosage, and location of polymer addition. The presence of interaction destroys the additivity of the main effects. For example, the effect of polymer dosage levels is not the same for every feed rate. The differences between the recovery means at CAT-FLOC dosages of 10 and 40 pounds per ton at 1 and 2 gpm are 19.86 and 7.79. The interaction (12.07) may be expressed as the amount remaining between the two differences. The polymer dosages, then, are simply more efficient at 1 gpm than at 2 gpm. Figure 15 clearly shows this interaction. Interpretation of the

Table 5
Summary of Digested Sludge Experiments

Identification		Machine and Process Variables										Responses			
Experiment Number	Data Table Number	Centrifugal Force	Pool Depth	Sludge Feed Rate	Sludge Concentration	Polymer	Polymer Dosage	Polymer Dosing Rate	Location Polymer Added	Recovery	Solids in Cake	Centrate Mobility	Centrate SCD Reading		
1	13		X			X		X					A		
2	14					X		X					A		
3	15	X				X							A		
4	16				X	X		X					A		
5	17	X				X							A		
6	18	X	X										A		
7	19	X	X										A		
8	20	X	X			X							A		

Table 5 - Continued

Identification		Machine and Process Variables										Responses				
Experiment Number	Data Table Number	Centrifugal Force	Pool Depth	Sludge Feed Rate	Sludge Concentration	Polymer	Polymer Dosage	Polymer Dosing Rate	Location Polymer Added	Recovery	Solids in Cake	Centrate Recoverability	Centrate SCD Reading	A	B	C
9	21		X			X		X						*	*	**
10	22		X			X		X								
11	6		X			X										

* Centrifuge A = 6x12 in. B = 24x38 in. C = 24x60 in.
 ** Location 1 = Univ. of Fla. 2 = Treasure Island 3 = St. Petersburg

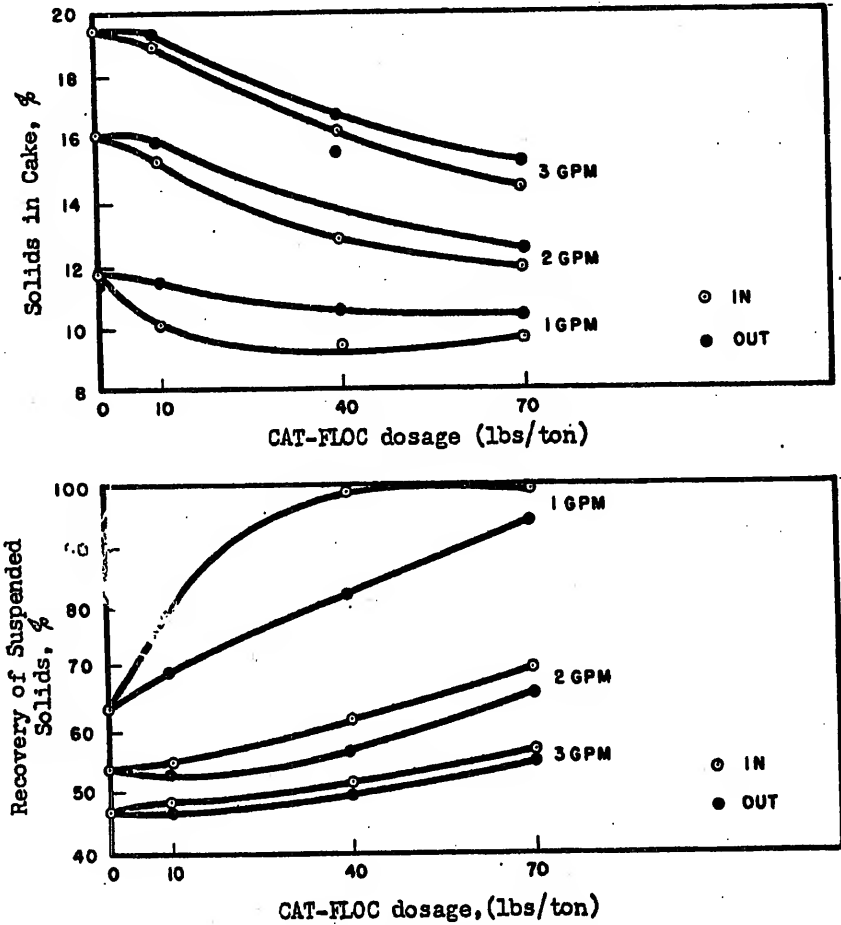

Fig. 15 - Effect of Sludge Feed Rate, Polymer Dosage, and Location Polymer Added on Performance of 6x12 Inch Centrifuge Dewatering Digested Sludge, University of Florida.

Centrifuge operation: 1180 x gravity, deep pool (0.594 in.)
Feed properties: SS = 4.24%; VSS = 64.57%; pH = 7.1
Polymer addition: Dosing rate 10% of sludge feed rate.

main effect is now possible and has significant meaning.

The mean square for error was small; therefore, the F test became very sensitive and detected all the interactions. The graphical presentation of the data in Figure 15 shows the effect of one variable on the other, and reliable conclusions as to the main effects can be derived in the presence of highly significant interactions. Each point plotted on the graph is the mean of two replicates for each treatment combination.

The results of Experiment 1 are:

(1) Sludge feed rate had the greatest effect on recovery and cake dewatering. As the feed rate increased the recovery decreased exponentially but the cake solids concentration increased exponentially.

(2) Recovery of suspended solids was more complete for a given CAT-FLOC dosage when the polymer was added within the centrifuge as opposed to addition outside the centrifuge. Recovery increased from 64 per cent to 95 per cent with CAT-FLOC dosages from 0 to 30 lbs/ton, but in order to recover the remaining 5 per cent suspended solids in the centrate, the CAT-FLOC dosage had to be doubled. Polymer addition was ineffective at sludge feed rates of 2 and 3 gpm. For example, at 2 gpm and CAT-FLOC dosage of 70 lbs/ton the recovery increased only 13 per cent.

(3) Cake solids concentration was inversely proportional to the recovery.

Experiment 2

This experiment was designed to study the surface charge properties of the particles remaining in the centrate as polymer dosage and location

of addition were varied. The experimental design was a completely randomized block.

Results - The results shown in Figure 16 may be summarized as follows:

(1) Polymer addition within the centrifuge was more effective in increasing the recovery efficiency than when the polymer was added either before or after the sludge feed pump.

(2) Electrophoretic mobility determinations on particles in the centrate showed that as recovery continued to improve, the electronegativity of the particles was reduced and approached zero. Recovery exceeding 99 per cent was attained when the particle mobility was reduced to zero. Polymer added in excess of this dosage reversed the mobility of the particles remaining in the centrate.

(3) The electronegativity of the sludge particles in the centrate increased upon centrifugation without any polymer addition. Support for this phenomenon is strengthened by electrophoretic mobility determinations prior to centrifuging which showed the average mobility of two samples to be $-1.5 \mu/\text{sec}/\sqrt{\text{cm}}$; but, after centrifugation the mobility of two samples was -2.0 and -3.0 respectively. To determine if this was an event dependent on the centrifugal force, the following experiment was designed.

Experiment 3

In this experiment centrifugal force and polymer dosage effects on dewatering digested sludge were determined. The experimental design was a split-plot.

Results - The results shown in Figure 17 may be summarized as follows:

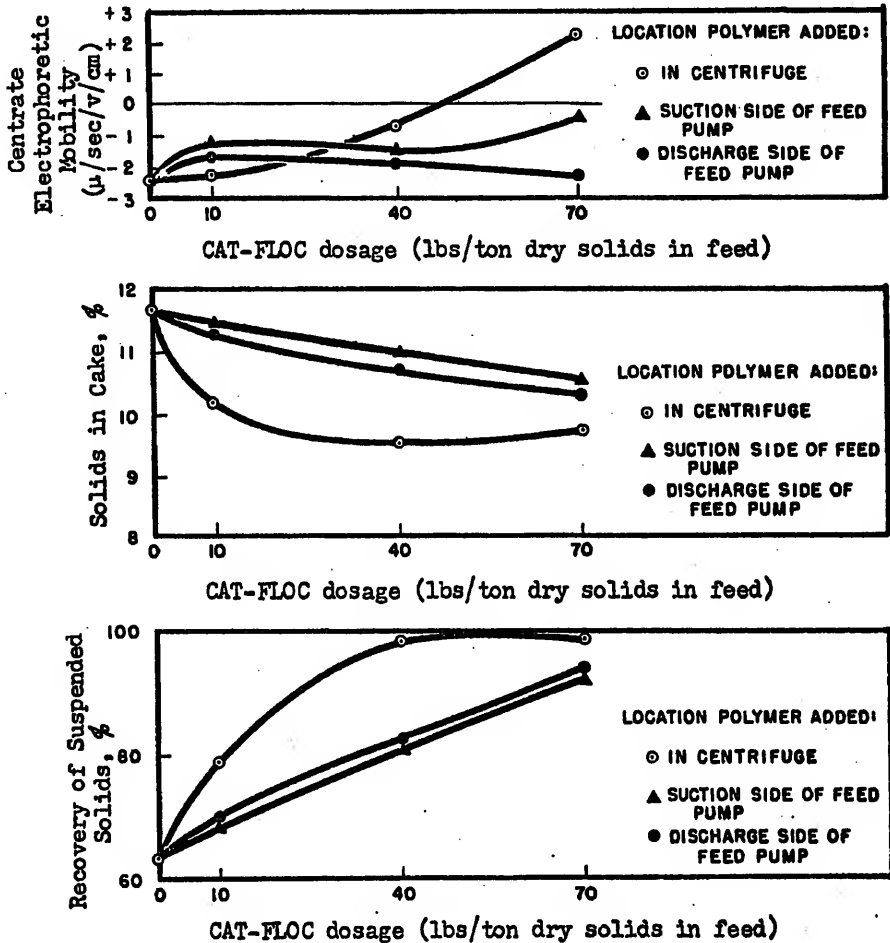

Fig. 16 - Effect of Polymer Dosage and Location Polymer Added on Performance of 6x12 Inch Centrifuge Dewatering Digested Sludge, University of Florida.

Centrifuge operation: 1180 x gravity, deep pool, feed rate 1 gpm.

Feed properties: SS = 4.24%, pH = 7.1, Mobility = -1.5 μ/sec/v/cm.

Polymer addition: Dosing rate 0.10 gpm.

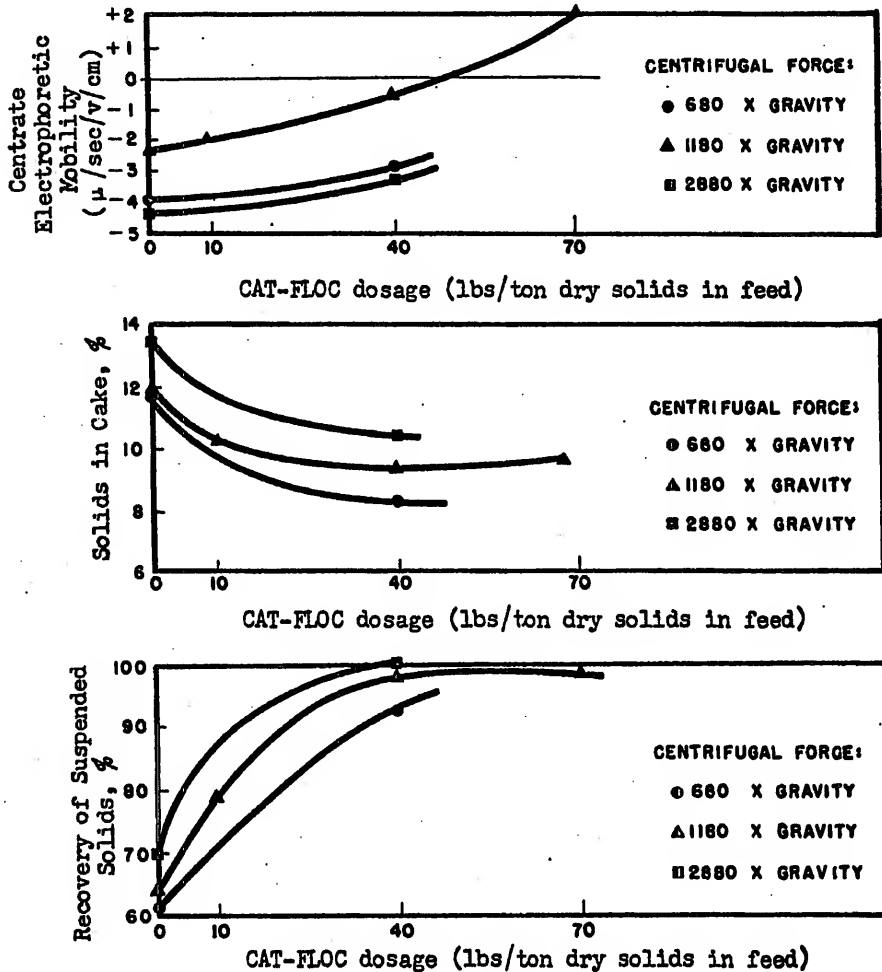

Fig. 17 - Effect of Centrifugal Force and Polymer Dosage on Performance of 6x12 Inch Centrifuge Dewatering Digested Sludge, University of Florida.

Centrifuge operation: Deep pool, feed rate 1 gpm.

Feed properties: SS = 4.24%, Mobility = -1.5 μ /sec/v/cm.

Polymer addition: Dosing rate 0.10 gpm within centrifuge.

(1) Recovery of suspended solids and cake solids concentration increased linearly as the centrifugal force increased. The analysis of variance supports this fact at the 1 per cent level of significance.

(2) An interesting phenomenon occurred; namely, the electrophoretic mobility of the suspended solids in the centrate accompanying dewatering without polymer treatment was dependent on the level of centrifugal force. The mobility was less when centrifuged at 1,180 times gravity than at 680 and 2,880 times gravity.

(3) Particle electronegativity was a function of polymer dosage only and appeared to be directly related to the initial particle charge. For example, when the particle mobility was $-2.5 \mu/\text{sec}/\text{v}/\text{cm}$ after centrifugation at 1,180 times the force of gravity, the mobility was reduced to $-0.5 \mu/\text{sec}/\text{v}/\text{cm}$ at an applied polymer dosage of 40 lbs/ton; but for an initial mobility of $-4.0 \mu/\text{sec}/\text{v}/\text{cm}$ at 680 times the force of gravity, the mobility was reduced to only $-3.0 \mu/\text{sec}/\text{v}/\text{cm}$.

Experiment 4

In this experiment the dewatering efficiency of three cationic polyelectrolytes was compared on the same sludge. The experiment was designed as a completely randomized block. The comparison basis was equal cost polymer dosages. The prices used for the polymers in this experiment were: Primafloc C-7 @ \$1.07 per pound; Purifloc C-31 @ \$0.34 per pound; and CAT-FLOC was assumed to be \$0.34 per pound, since CAT-FLOC was not then commercially available.

Results - The results of this experiment are shown in Figure 18 and may be summarized as follows:

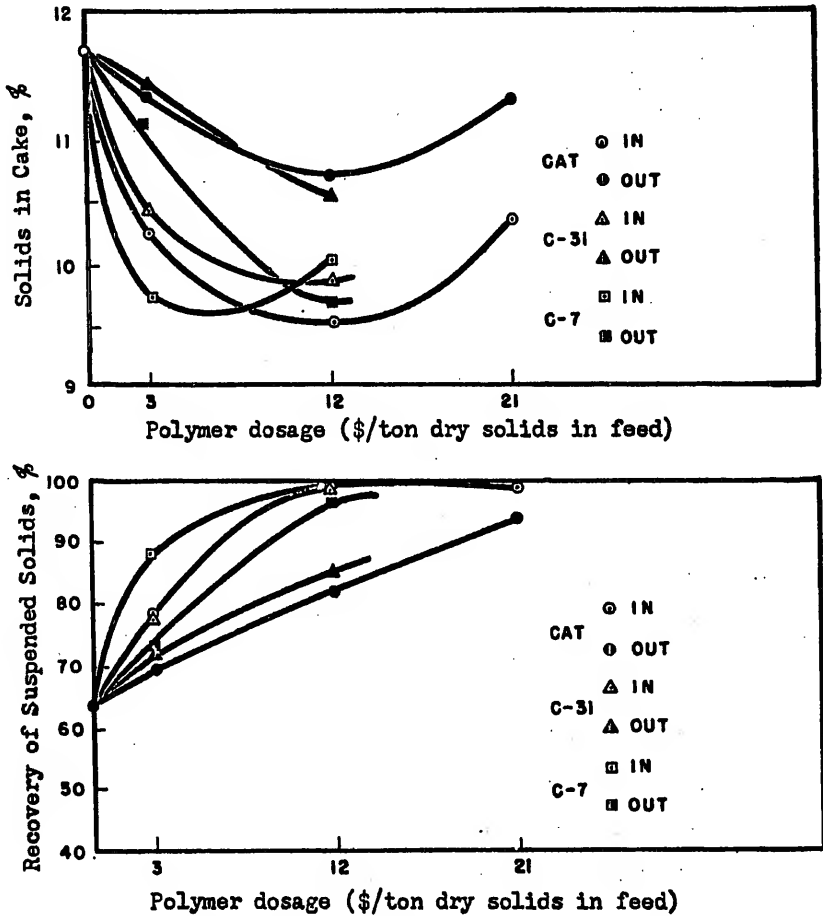

Fig. 18 - Effect of Three Cationic Polymers and Location of Polymer Addition on the Performance of 6x12 Inch Centrifuge Dewatering Digested Sludge, University of Florida.

Centrifuge operation: 1,180 x gravity; deep pool; feed rate 1 gpm.

Feed properties; SS = 4.24%; alkalinity = 1810; pH = 7.1

Polymer addition: Dosing rate 0.10 gpm.

(1) All three polymers increased suspended solids recovery more effectively when added within the centrifuge.

(2) CAT-FLOC and Purifloc C-31 performed nearly the same on the basis of recovery and cake solids concentration.

(3) Primafloc C-7 was better than the other two polymers at lower dosages, giving higher recoveries and drier cakes. . . . A given dosage beyond that required for 90 per cent recovery was accompanied by a decrease in moisture content of the cake.

Experiment 5

This experiment was prompted by the results observed in Experiment 3 as shown in Figure 17 where the particle mobility in the centrate did not reflect the recovery efficiency. For example, at a centrifugal force of 1,180 times gravity the recovery was 98 per cent and the centrate particles had an average mobility of $-0.5 \mu/\text{sec}/\text{v}/\text{cm}$; however, 99.9 per cent recovery at a centrifugal force of 2,880 times gravity was accompanied by centrate particles having an average mobility of $-3.1 \mu/\text{sec}/\text{v}/\text{cm}$. To provide additional information on the centrate particle charge and centrate clarification streaming current determinations were made on centrate samples. In addition, the residual-free CAT-FLOC polymer in the centrate was determined by the colorimetric technique. This experiment was designed as a split-plot.

Results - Figure 19 shows the results which may be summarized as follows:

(1) The electrophoretic mobility of the suspended solids in the centrate increased negatively upon centrifugation without polymer

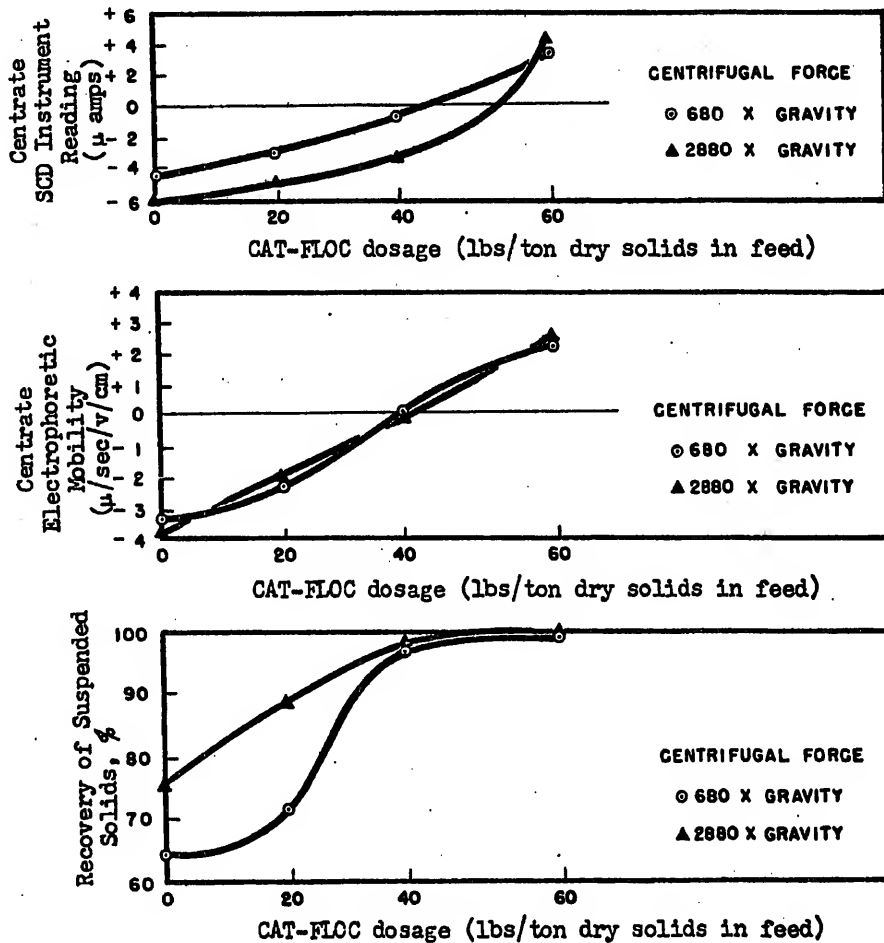

Fig. 19 - Effect of Centrifugal Force and Polymer Dosage on Electrophoretic Mobility and Streaming Current Response of Particles in Centrate When Dewatering Digested Sludge, University of Florida.

Centrifuge operation: Deep pool (0.594 in); feed rate 1 gpm.

Feed properties: SS = 3.45%; pH = 7.0; Mobility = -1.8μ /sec/v/cm.

Polymer addition: Dosing rate 0.10 gpm within centrifuge.

treatment. The average initial feed sludge mobility was $-1.8 \mu/\text{sec}/\sqrt{\text{cm}}$, but after centrifugation without polymer treatment the average mobility was -3.2 and $-3.8 \mu/\text{sec}/\sqrt{\text{cm}}$ at 680 and 1,180 times the force of gravity respectively. Particle mobility was reduced to zero at a CAT-FLOC dosage of 40 lbs/ton and recovery was approximately 98 per cent. The results contradict those obtained in Experiment 3 but support those of Experiment 2.

(2) The streaming current instrument recorded zero streaming current at polymer dosages different than those determined by electrophoretic mobility determinations although the trend in charge reduction was similar. No additional information of value can be extracted from this use of the Streaming Current Detector instrument in this experiment; however, it was used in subsequent experiments.

(3) Determinations for CAT-FLOC did not detect any residual at dosages up to 40 lbs/ton; however, at dosages of 70 lbs/ton the average residuals were 4 mg/l for centrate collected at 680 times the force of gravity and 20 mg/l for samples centrifuged at 2,880 times the force of gravity.

Experiment 6

The experiments up to this point have evaluated the effect of centrifugal force and feed rate at a constant deep pool depth. Pool depth is the second and the last machine variable possible to investigate in these pilot-plant experiments with Bird 6 x 12 inch solid bowl centrifuge.

The effect of centrifugal force, pool depth, and sludge feed rate

were determined in this experiment. The experimental design was a split-plot.

Results - Figure 20 shows the results obtained. These were:

(1) Pool depth affects recovery of suspended solids and cake solids concentration to an extent greater than centrifugal force and feed rate. Pool depth acts linearly in its effect on decreasing recovery and cake moisture content.

(2) The effects of feed rate were the same as previously found in Experiment 1.

(3) The effect of increasing the centrifugal force was significant at the 5 per cent level in increasing recovery as the centrifugal force increased, but insignificant in accounting for a drier cake product.

Experiments 7 and 8

The results of Experiments 1 through 6 have shown that centrifugation can achieve clarity of centrate or cake dryness, but not both of these desired responses simultaneously. The two following experiments were designed to evaluate the effect of the feed sludge concentration at conditions which would give good clarity or a dry cake. For the best clarity a deep pool depth and a low feed rate was used. For the driest cake a shallow pool depth and a high feed rate was used. The centrifuge was operated at centrifugal forces of 680 and 2,880 times the force of gravity and the polymer was introduced within the centrifuge bowl at a volumetric rate equivalent to 10 per cent of the sludge feed rate.

The experiments were of the split-split-plot design. The results of the deep pool experiment are shown in Figure 21 and the results of the shallow pool experiment are shown in Figure 22.

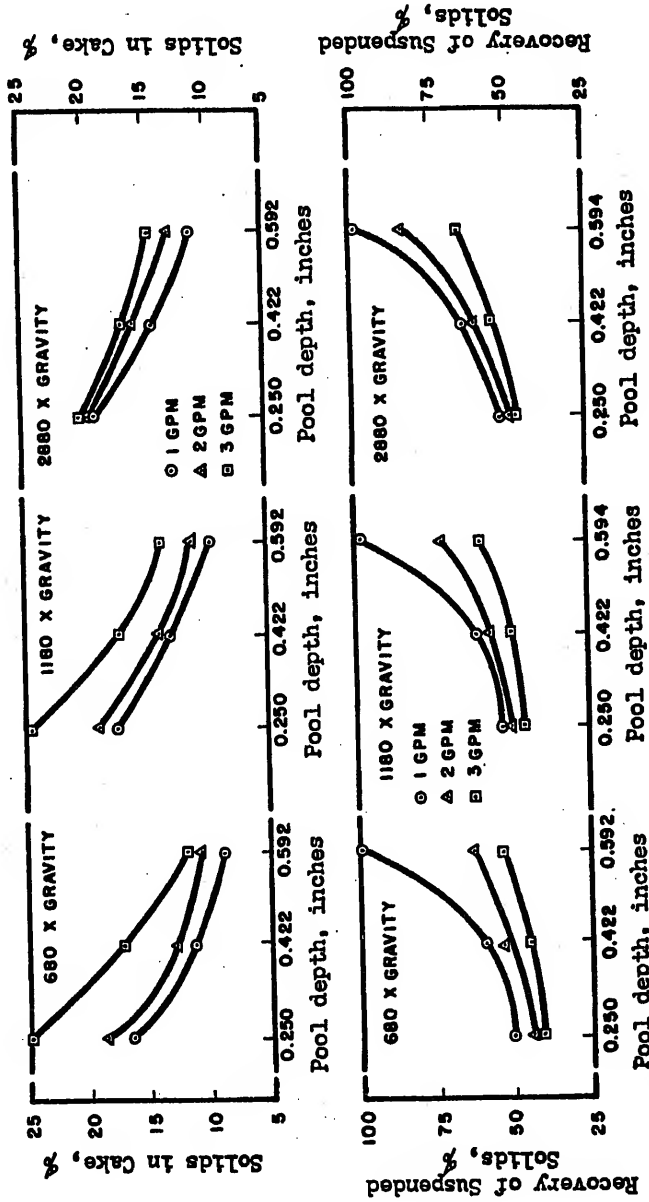

Fig. 20 - Effect of Centrifugal Force, Feed Rate, and Pool Depth on Performance of 6x12 Inch Centrifuge Dewatering Digested Sludge, University of Florida.

Centrifuge operation: Shallow, medium and deep pool depth.
Feed properties: SS = 2.51%; VSS = 68.42%; Alk. = 1590.
Polymer addition: Purifloc C-3L, dosage of 40 lbs/ton added continuously at 10% of sludge feed rate.

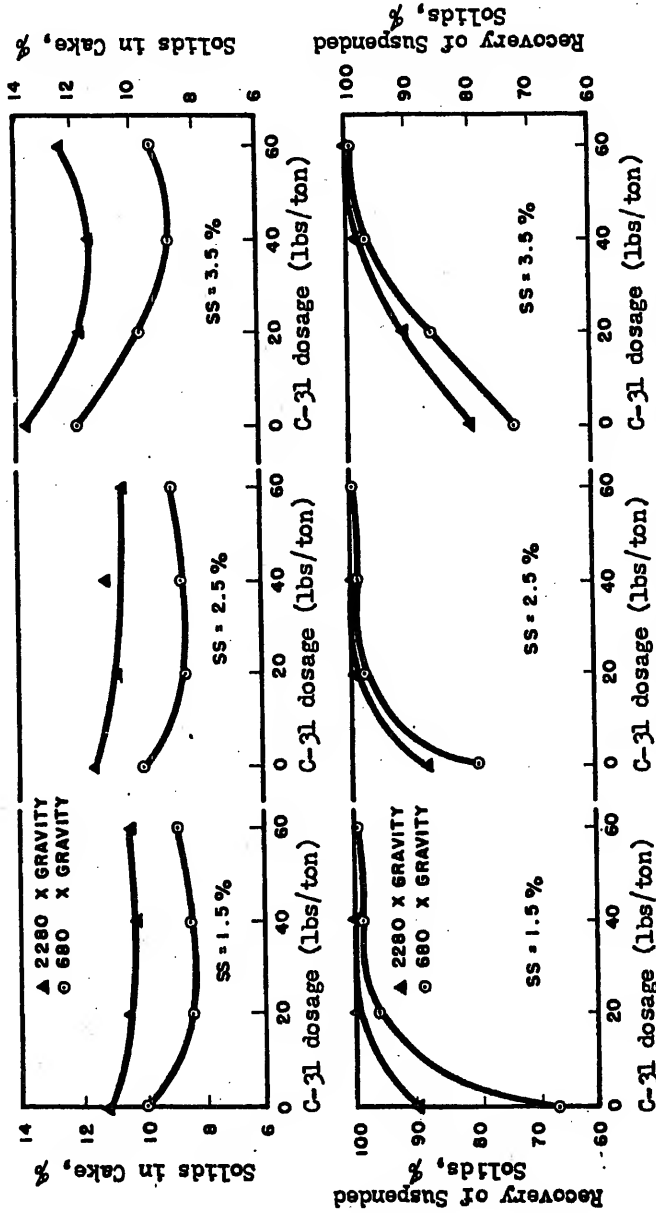

Fig. 21 - Effect of Sludge Concentration, Centrifugal Force, and Polymer Dosage on Performance of 6x12 Inch Centrifuge Dewatering Digested Sludge, University of Florida.

Centrifuge operation: Deep pool (0.594 in.); feed rate 1 gpm.

Feed properties: See Table 19.

Polymer addition: Dow Purifloc C-3l added within centrifuge at 0.10 gpm.

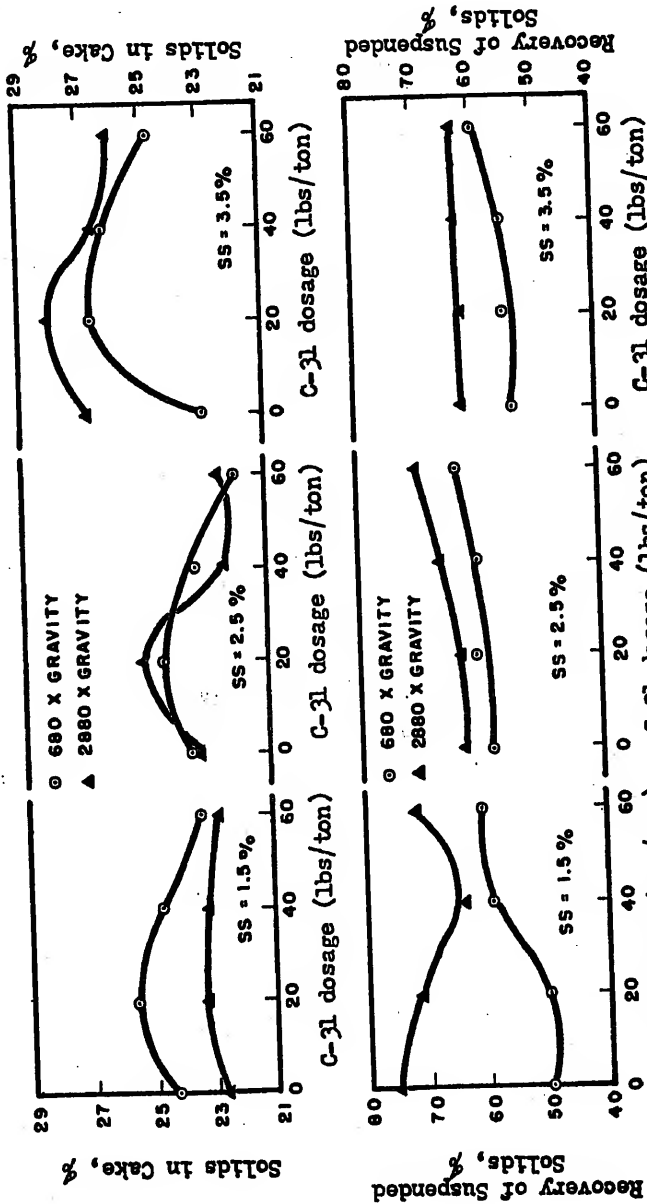

Fig. 22 - Effect of Sludge Concentration, Centrifugal Force, and Polymer Dosage on Performance of 6x12 Inch Centrifuge Dewatering Digested Sludge, University of Florida.

Centrifuge operation: Shallow pool (0.250 in.); feed rate 3 gpm.

Feed properties: See Table 20.

Polymer addition: Dow Purifloc C-31 added within centrifuge at 0.3 gpm.

Results - The analysis of variance for data of Experiment 7 shows that:

(1) As feed sludge concentration increases it has the highly significant effect of decreasing recovery and increasing cake solids concentration. Figure 21 shows this effect clearly regardless of the two and three factor interactions between the variables.

(2) As feed concentration increased, the cake moisture content reached a maximum, then decreased as recovery continued to improve.

(3) Centrifugal force and polymer dosage had the effects on recovery and cake solids concentration as noted in previous experiments.

The analysis of variance for data of Experiment 8 shows that at a shallow pool depth and a high feed rate (a) recovery decreases as feed concentration increases, (b) recovery increases as the centrifugal force increases, (c) recovery increases only slightly as polymer dosage increases, and (d) sludge concentration, centrifugal force, and polymer dosage had ambiguous effects on cake solids concentration.

The eight experiments just described completed the research on dewatering digested sludge at the University of Florida Sewage Treatment Plant. Experiments then were conducted on digested sludge at the Water Pollution Control Plant, Treasure Island, Florida.

Experiments 9 and 10

Experiments conducted at the Treasure Island Water Pollution Control Plant included performance tests of the Bird 6 x 12 inch and the Bird 24 x 38 inch centrifuges. The experimental designs were split-plot. Figure 23 shows the results of the 6 x 12 inch centrifuge performance

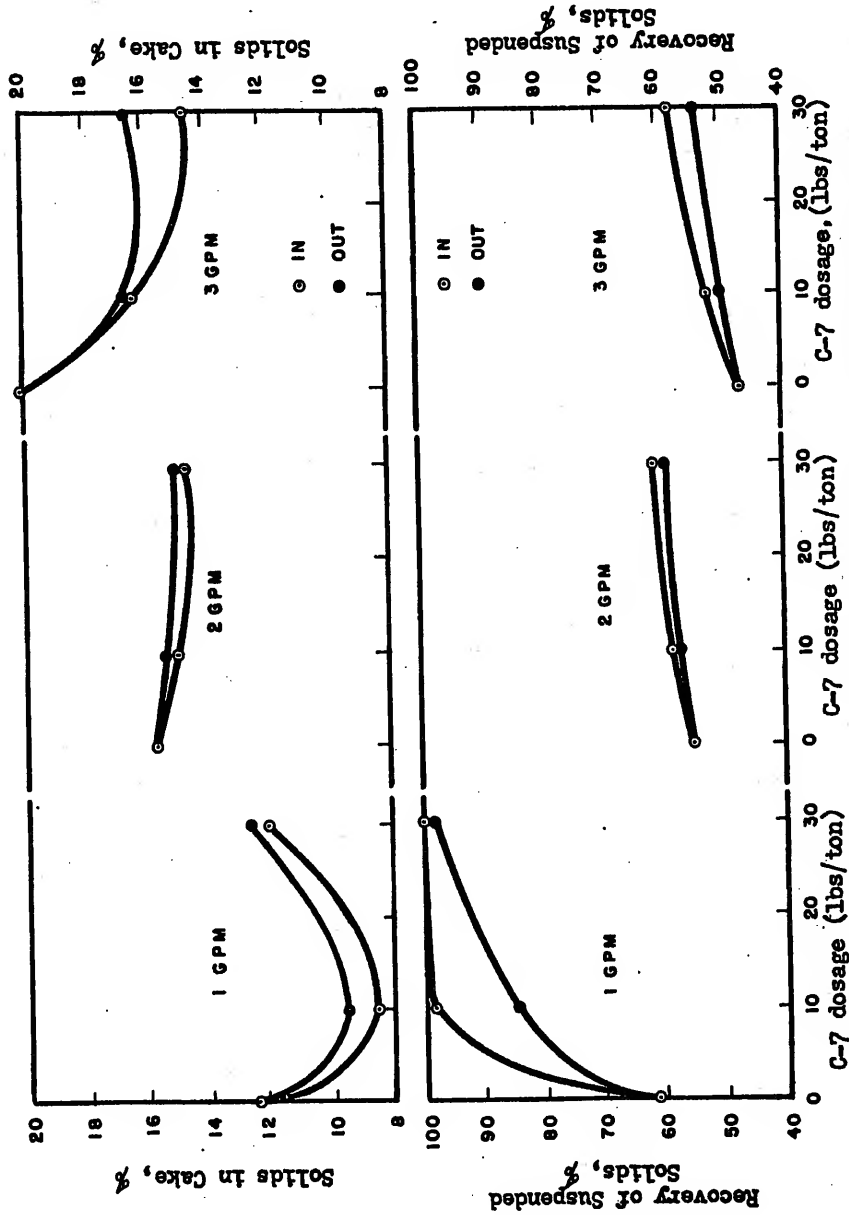

Fig. 23 - Effect of Feed Rate, Polymer Dosage, and Location Polymer Added on Performance of 6x12 Inch Centrifuge Dewatering Digested Sludge, Treasure Island, Fla.
Conditions: 1180 x gravity; deep pool, SS = 3.48%.

dewatering digested sludge when operating at a centrifugal force of 1,180 times gravity and a deep pool depth of 0.594 inches. Primaflor C-7 was added at a dosing rate equivalent to 10 per cent of the sludge feed rate.

Results - The following results were observed:

(1) Recovery fell off sharply as the feed rate was doubled and then tripled. The solids conveying capacity of the scroll conveyor was not exceeded.

(2) Polymer addition within or outside the centrifuge had no significant effect of increasing recovery at the 2 and 3 gpm feed rates. The retention times within the centrifuge at these sludge feed rates were reduced to 12.3 and 8.3 seconds, respectively. The retention within the machine was 24.5 seconds at 1 gpm and was sufficient to obtain recoveries in excess of 90 per cent at a reasonable polymer dosage between 5 to 10 pounds of Primaflor C-7 per ton of dry solids in the feed.

(3) Excess polymer above that required to clear up the centrate increased the sludge cake dryness.

Performance of the 24 x 38 inch centrifuge dewatering the same digested sludge at approximately the same concentration was evaluated the following day. Figure 24 shows the results of the 24 x 38 inch centrifuge performance operating at a centrifugal force of 1,335 times gravity and a deep pool depth of 2.4 inches. Primaflor C-7 was added at a dosing rate equivalent to 10 per cent of the sludge feed rate. Tests with a poor quality centrate had to be kept to a minimum to avoid upsetting the treatment process at the Treasure Island Treatment Plant.

Results - Polymer dosage, feed rate, and location of polymer

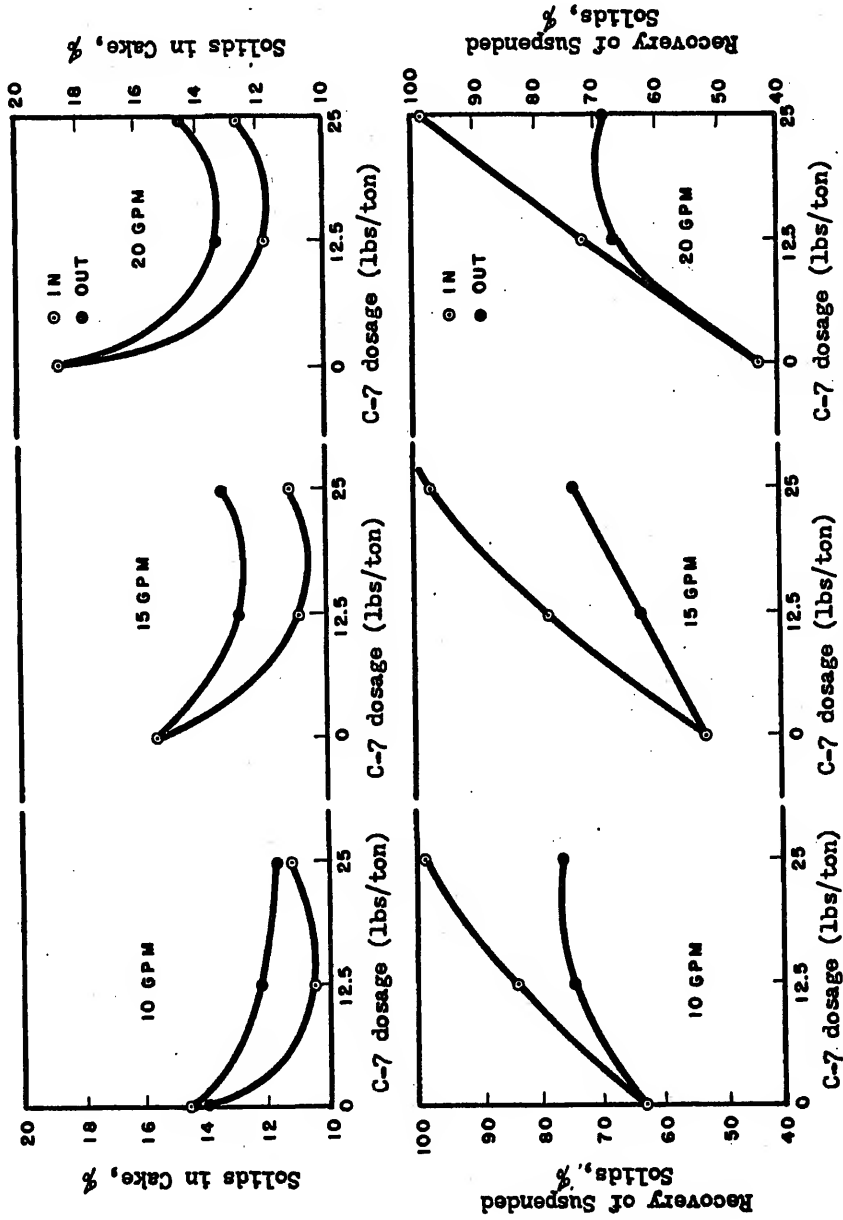

Fig. 24 - Effect of Feed Rate, Polymer Dosage, and Location Polymer Added on Performance of 24 x 38 Inch Centrifuge Dewatering Digested Sludge, Treasure Island, Fla.

Conditions: 1,335 x gravity; deep pool; SS = 3.61%.

addition produced the same effects as observed in the performance of the 6 x 12 inch machine on the same sludge.

The following experiment was conducted at the Northeast Sewage Treatment Plant in St. Petersburg, Florida.

Experiment 11

Dewatering of digested sludge with the 24 x 60 inch centrifuge at St. Petersburg was limited to a few test runs. Prior to centrifuging the digested sludge, work had already been done in dewatering the waste sludge. Since the digested sludge exhibited the same characteristics as the waste sludge, similar results were anticipated. The digested sludge was incompletely digested, and the suspended solids concentration was 2.5 per cent. The digester profile was nearly uniform throughout the depth and for months there had been no clear supernatant. Approximately ten test runs were conducted at a feed rate of 25 and 50 gpm. The sludge pump, a Moyno SW 12H, was oversized. It caused surging when operated at rates from 25 to 75 gpm and frequently plugged when operated at 25 gpm. Further testing was discontinued until the correct sized feed pump could be installed. In October, 1967, a Moyno SW 10H sludge feed pump was available and the Bird Machine Company conducted tests to determine the performance of the 24 x 60 inch machine.

Results - Tests conducted using the SW 12H feed pump determined that:

- (1) Polymer addition to improve recovery was ineffective under the circumstances of a surging and erratic feed rate.
- (2) Suspended solids recovery averaged 35 per cent without polymer

Table 6

Performance of 24 x 60 Inch Centrifuge Dewatering Digested Sludge, St. Petersburg, Fla.

Pool Depth Setting	Feed Rate (gpm)	Polymer Dosage (lbs/ton) ^a	Recovery of Suspended Solids Per cent	Solids in Cake Per cent
#2	23	0	43.71	12.60*
#2	28	0	39.77	14.30*
#2	38	0	28.94	16.20*
#2	60	0	17.61	16.30*
#2	86	0	17.04	21.30*
#4	50	0	35.90	10.90**
#4	50	0	34.72	13.00**
#4	50	48	40.21	10.92**

*Results of tests conducted by Steve Roach, Engineer, Bird Machine Co., (October, 1967) after installation of SW10H Moyno sludge feed pump, average suspended solids = 2.8%.

**Tests conducted by author (July, 1967) with SW12H Moyno pump.

^aPolymer dosage in pounds Purifloc C-31 per ton of dry solids in feed, added in centrifuge at 15 gpm.

addition at a 50 gpm feed rate.

Tests conducted by Bird Machine Company with the SW 10H sludge feed pump determined that:

- (1) Recovery decreased with increasing feed rate.
- (2) The sludge was difficult to dewater.

Results of both tests are shown in Table 6.

Dewatering Activated Sludge

The results of experiments conducted on activated sludge are shown in Figures 25 through 35. The variables investigated and the responses observed are shown in Table 7.

Experiment 12

This experiment evaluated the effect of sludge feed rate, polymer dosage, and location of polymer addition on dewatering return activated sludge. The experimental design was of the split-plot with two replicates made of each treatment combination.

Results - Figure 25 shows that this sludge with a SVI of 227 was very difficult to dewater. The observed results were:

- (1) Polymer doses were extremely high to recover just 90 per cent of the suspended solids from the feed sludge. Polymer dosage was more effective when added in the centrifuge.
- (2) Electrophoretic mobility and streaming current determinations showed that particle charge reduction was extremely slow, and therefore high polymer dosages were required.
- (3) The suspended solids discharged with the centrate were flocculated, but would not settle; frequently they floated to the top of the

Table 7 - Continued

Identification		Machine and Process Variables										Responses		
Experiment Number	Data Table Number	Centrifugal Force	Pool Depth	Sludge Feed Rate	Sludge Concentration	Polymer	Polymer Dosage	Polymer Dosing Rate	Location Polymer Added	Recovery	Solids in Cake	Centrate Mobility	Centrate SCD Reading	
20	31		X			X	X	X					C*	
21	32					X	X	X					C	

* Centrifuge A = 6x12 in. B = 24x38 in. C = 24x60 in.
 ** Location 1 = Univ. of Fla. 2 = Treasure Island 3 = St. Petersburg

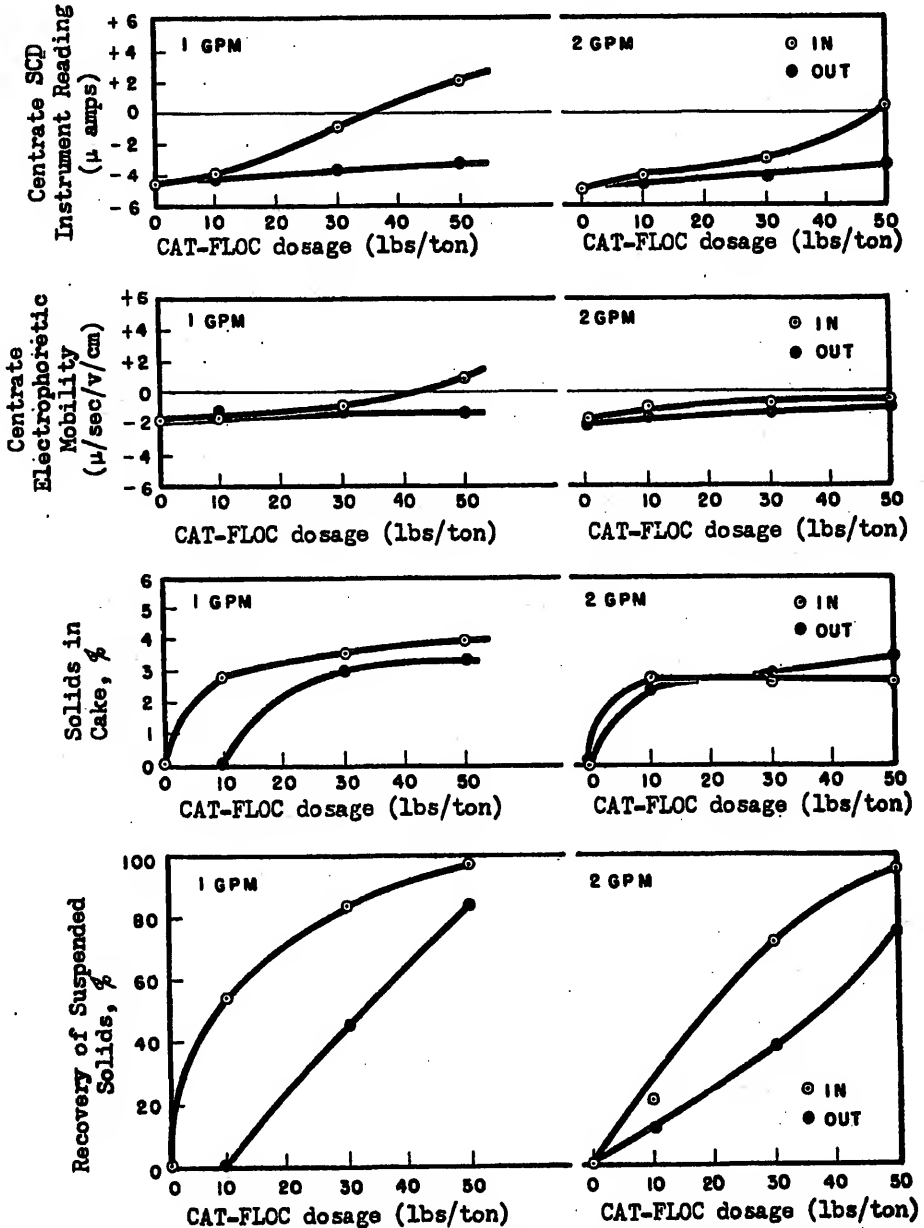

Fig. 25 - Effect of Feed Rate, Polymer Dosage, and Location Polymer Added on Performance of 6x12 Inch Centrifuge Dewatering Return Activated Sludge, University of Florida.

Conditions: 1,180 x gravity; deep pool (0.594 in.);
 SS = 0.44%. Mobility = -1.8 μ /sec/v/cm;
 SCD = -30 μ amps.

sample. This condition was associated with insufficient polymer dosage.

(4) Zero recovery of suspended solids occurred randomly following test runs where a good cake was obtained, thus eliminating the possibility that the solids were slipping under the conveyor scroll. The centrifuge was disassembled the first time the phenomenon occurred to verify that an annular liner of grit and sludge cake had filled the space between the conveyor scroll blades and the bowl wall. The explanation for the phenomenon must be the resuspension of the solids by the scroll conveyor and turbulence caused by the flow through velocity. Centrate samples taken during this event were analyzed for suspended solids concentration and nearly always found to be the same concentration as the feed sludge.

(5) Sludge feed rate did not have a significant effect on any of the four responses according to the analysis of variance.

(6) As recovery increased the cake moisture content decreased.

(7) The changes in the Streaming Current Detector readings (in arbitrary microamps) were reduced and reversed in sign with increased polymer addition. For the 1 gpm feed rate the zero reading was at 35 lbs/ton CAT-FLOC; however, the zero mobility was at -40 lbs/ton CAT-FLOC dry solids in the feed. The SCD instrument responses followed the trends of electrophoretic mobility determinations.

Experiment 13

This experiment was designed to study the effect of centrifugal force, feed rate, and polymer dosage. The experimental design was a split-plot.

Results - The curves shown in Figures 26 and 27 indicate the following results:

- (1) Recovery at low polymer dosages was impossible at a centrifugal force of 2,880 times gravity.
- (2) Cake discharged at a centrifugal force of 2,880 times gravity was drier for a given polymer dosage than it was at 680 times gravity.
- (3) As sludge feed rate increased the recovery decreased and a wetter sludge cake was produced.
- (4) Polymer dosages were high to obtain a 90 per cent recovery.
- (5) The driest cake discharged had a moisture content of 97 per cent at a recovery of 99+ per cent.
- (6) Residual CAT-FLOC tests showed (a) 0 mg/l CAT-FLOC in the centrate samples which had a negative mobility when centrifuged at 680 times gravity; (b) 0-5 mg/l CAT-FLOC in those centrate samples with a positive electrophoretic mobility when centrifuged at 680 times gravity; and (c) 0 mg/l CAT-FLOC residual in all samples centrifuged at 2,880 times gravity. Mobility value determinations of suspended solids in the centrate showed a decrease in negativity with an increase in polymer dosages. The initial mobility of the activated suspended solids was altered by centrifugation as it was for the digested sludge. It is interesting to note that the effect was not as great for centrifugation at 1,180 times gravity shown in Figure 25.
- (7) Streaming Current Detector responses followed the trend in the electrophoretic mobility reduction. The SCD reading at 50 lbs/ton appears to be due to experimental error.

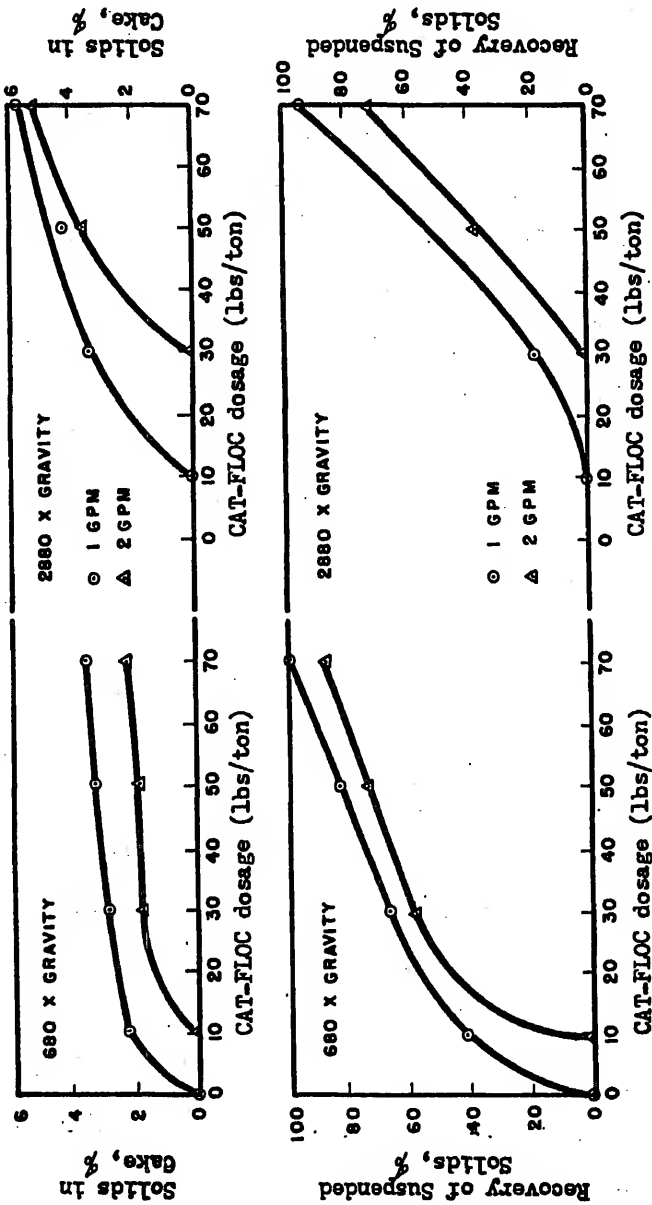

Fig. 26 - Effect of Centrifugal Force, Feed Rate, and Polymer Dosage on Performance of 6x12 Inch Centrifuge Activated Sludge, University of Florida.

Centrifuge operation: Deep pool (0.594 in.).
Feed properties: SS = 0.50%; VSS = 80.94%; SVI = 200; Mobility = 2.5 μ /sec/v/cm.

Polymer addition: Dosing rate 10% of sludge feed rate.

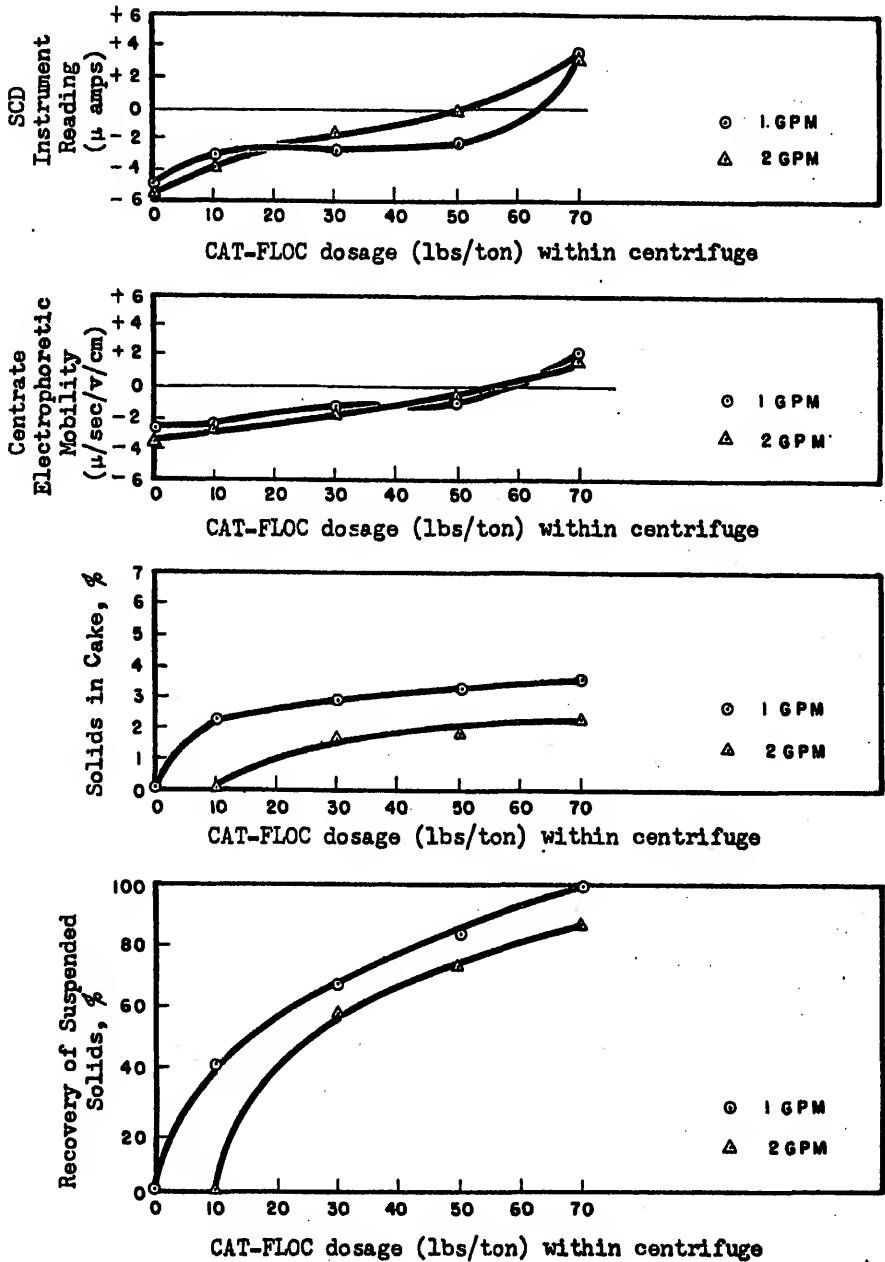

Fig. 27 - Effect of Centrifugal Force, Feed Rate, and Polymer Dosage on Performance of 6x12 Inch Centrifuge Dewatering Return Activated Sludge, University of Florida.

Experiment 14

This experiment was designed to study the effect of centrifugal force, sludge feed rate, polymer dosage and sludge volume index on dewatering activated sludge. The experiment was designed as a split-split-plot.

Results - Figure 28 shows the following results:

- (1) The sludge, with a SVI of 115, dewatered readily at low chemical dosages. Ninety per cent recovery was obtained without any polymer addition; however, removal of the last percentage of suspended fines (particles passing through the 200 mesh sieve) could not be accomplished at polymer dosages tried in this experiment.
- (2) The best recovery was obtained at an intermediate centrifugal force of 1,180 times gravity.
- (3) Feed rate had a significant but small effect in comparison to the other variables in decreasing recovery.
- (4) CAT-FLOC dosage accounted for the most significant increase in recovery.

Experiment 15

The purpose of this experiment was to collect data on the performance of the 6 x 12 inch centrifuge at Treasure Island and compare them with the 24 x 38 inch centrifuge at this treatment plant. The experimental design was a split-split-plot. The effect of centrifugal force, sludge feed rate, and polymer dosage are shown in Figure 29.

Results - The results in this experiment support the previous findings in dewatering activated sludge, namely:

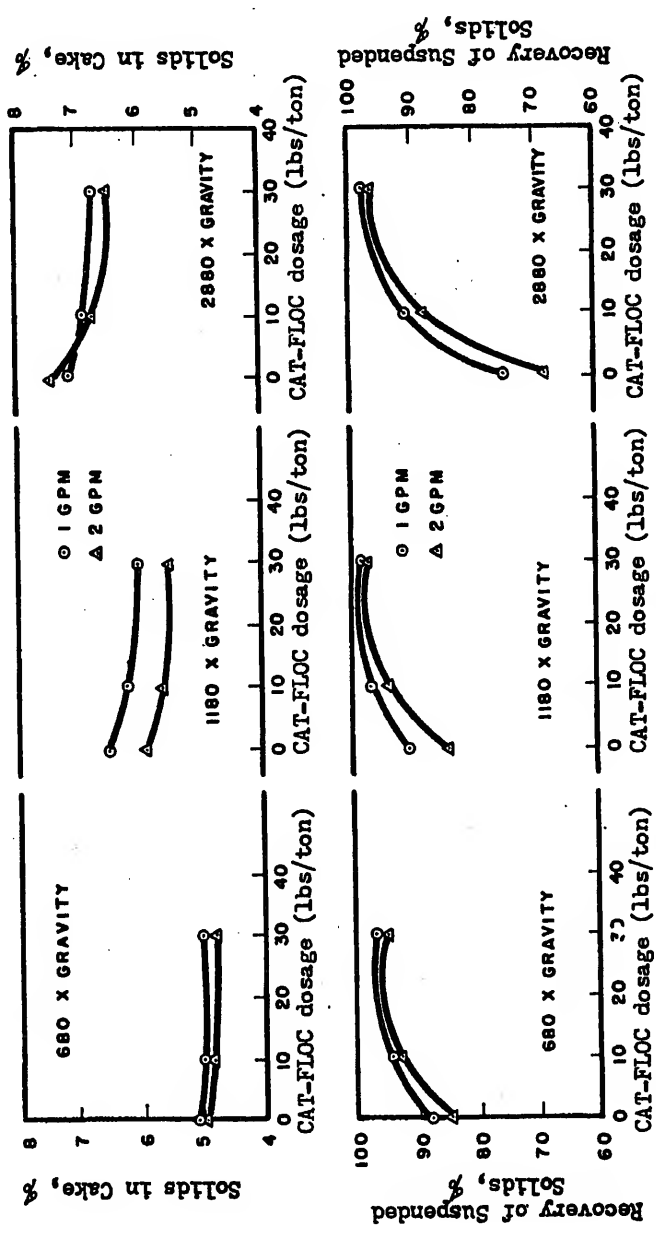

Fig. 28 - Effect of Centrifugal Force, Feed Rate, and Polymer Dosage on Performance of 6x12 Inch Centrifuge Sludge From Extended Aeration Unit, University of Florida.

Centrifuge operation: Deep pool (0.594 in.)
 Feed properties: SS = 0.72%; VSS = 81.10%; SVI = 115.
 Polymer addition: Designate 10% of feed rate.

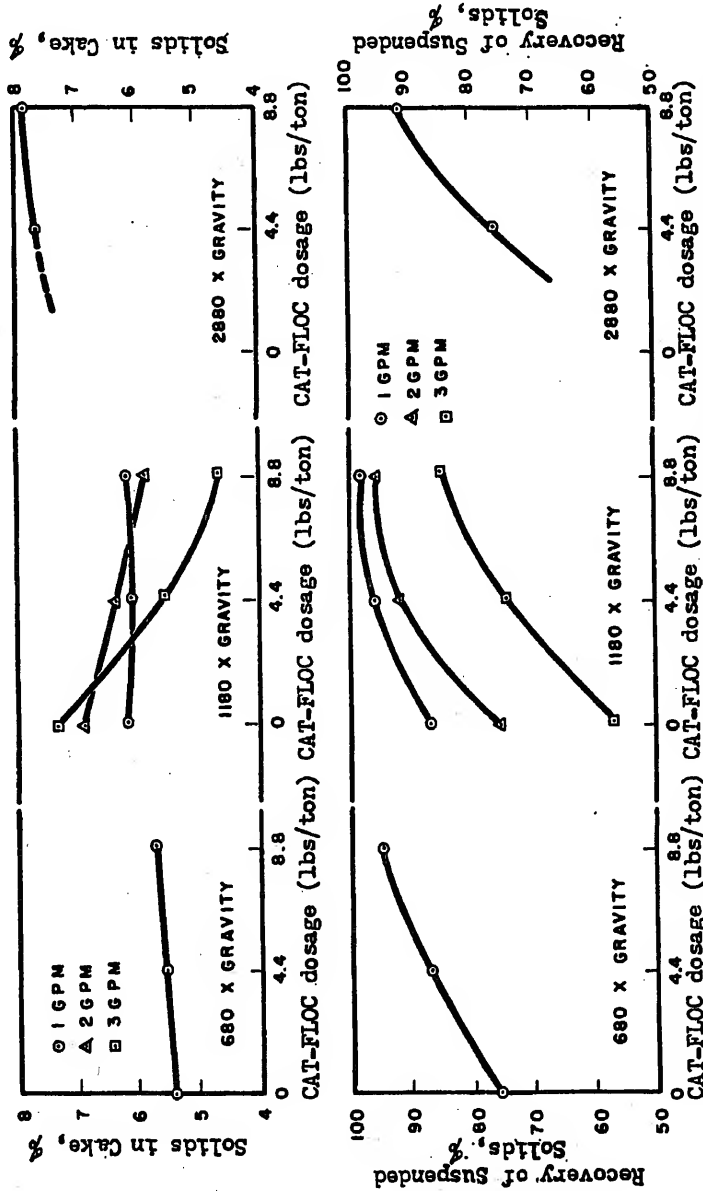

Fig. 29 - Effect of Centrifugal Force, Feed Rate, and Polymer Dosage on Performance of 6x12 Inch Centrifuge Return Sludge, Treasure Island, Fla.

Centrifuge operation: Deep pool (0.594 in.).
 Feed properties: SS = 0.90%; SVI = 105; alkalinity = 320.
 Polymer addition: Dosing rate 1.0% of sludge feed rate.

- (1) Recovery of suspended solids is more efficient at the intermediate centrifugal force of 1,180 times gravity.
- (2) Increase in feed rate decreases recovery.
- (3) Settling characteristics of the sludge as measured by SVI was a good indicator of ease of dewatering by centrifugation.

Experiment 16

This experiment was performed to compare the results of machine performance with the 6 x 12 inch machine. The experimental design was a completely randomized block. The effect of polymer dosing rate was tested within this experiment and determined by the analysis of variance not to be significant in effecting recovery; however, as the dosing rate increased, a significant increase in cake moisture content occurred.

Results - Trends in recovery and cake solids concentration obtained with the 24 x 38 inch machine, shown in Figure 30, appear to have been similar to those obtained for the 6 x 12 inch machine by visual inspection of Figure 29. However, the machines are compared on a sedimentation versus Q/Σ basis in Figure 38.

Polymer dosage was very high to achieve recoveries in excess of 90 per cent. However, as the feed rate increased the recoveries approached the same value and at a Primafloc C-7 dosage of 30 lbs/ton (approximately \$30.00 per ton) recovery was nearly 100 per cent at 20, 30, or 40 gpm. Solids loading rate at 40 gpm was 200 pounds per hour. The design capacity of the machine was not known.

Experiment 17

This experiment evaluated the performance of the 6 x 12 inch

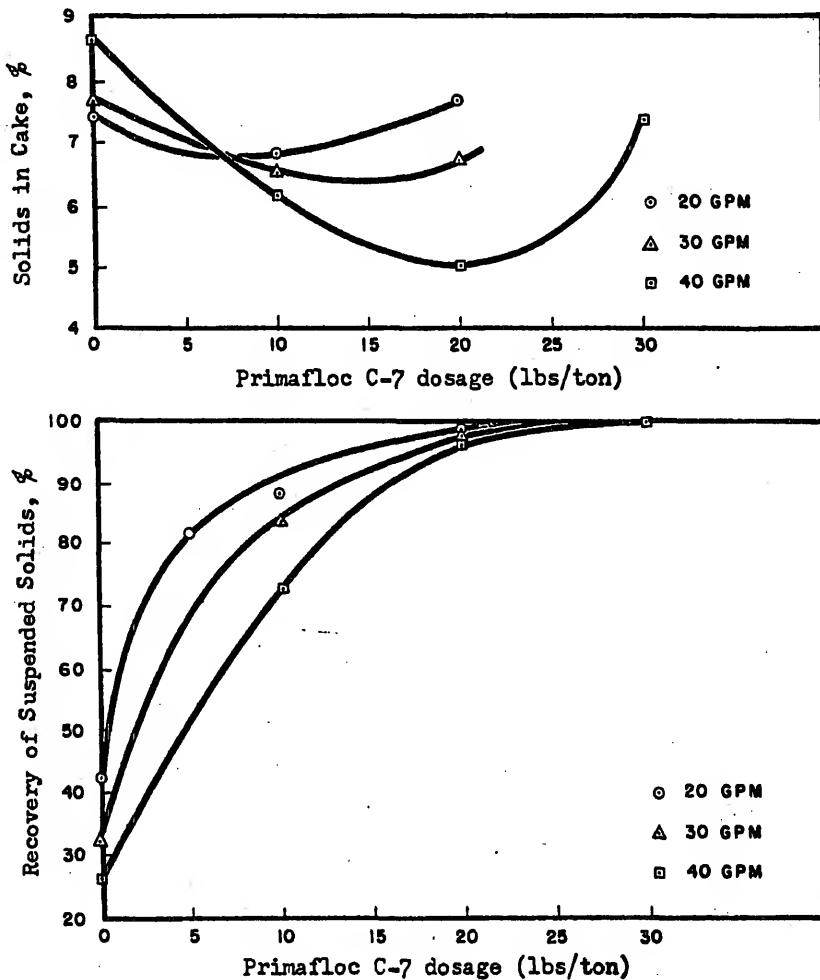

Fig. 30 - Effect of Feed Rate and Polymer Dosage on Performance of 24 x 38 Inch Centrifuge Return Sludge, Treasure Island, Fla.

Centrifuge operation: 1,335 x gravity; deep pool depth.
Feed properties: SS = 1.04%; SVI = 115; alkalinity = 375.
Polymer addition: Dosing rate 10% of sludge feed rate.

centrifuge dewatering waste activated sludge from the high rate activated aeration process at St. Petersburg. The tests were accomplished a few days before a new 24 x 60 inch concurrent flow centrifuge was installed and started up. This experiment was designed to determine the effect of centrifugal force, feed rate, and polymer dosage on recovery of suspended solids and the concentration of cake solids. The treatments were arranged in a split-split-plot design.

Results - Figure 31 shows the results of this experiment which may be summarized as follows:

(1) Centrifugal force was not significant at the 5 per cent level in altering the recovery of the suspended solids; however, it was highly significant in discharging a cake with a lower moisture content.

(2) The most important characteristic was the rapid increase in polymer demand when the feed rate was increased. The results of this test showed that the sludge required a substantial amount of polymer to recover 95 per cent of the suspended solids. This was not unusual based on previous testing at the University of Florida and Treasure Island.

Experiment 18

The effect of polymer dosing rate on recovery and cake moisture content had been determined during preliminary testing at the University of Florida. A polymer volumetric dosing rate of 10 per cent of the sludge feed rate consistently produced the highest recovery in the 6 x 12 inch machine. This experiment was to determine the polymer dosing rate effect upon recovery of suspended solids from the waste sludge at St. Petersburg and was conducted with the 6 x 12 inch centrifuge. Two feed

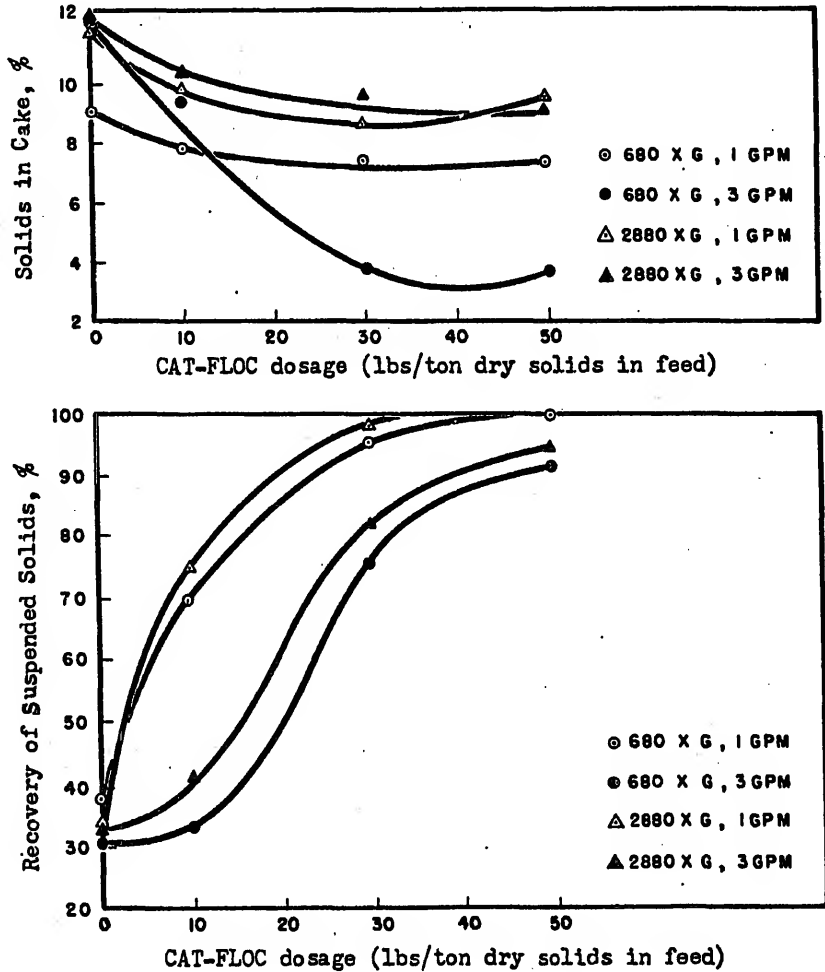

Fig. 31 - Effect of Centrifugal Force, Sludge Feed Rate, and Polymer Dosage on Performance of 6x12 Inch Centrifuge Dewatering Waste Sludge, St. Petersburg, Fla.

Centrifuge operation: Deep pool depth (0.594 inches).
Feed properties: SS = 2.80; pH = 6.5; alkalinity = 560.
Polymer addition: Dosing rate 10% of sludge feed rate.

rates were included in the experiment but only the 1 gpm results are shown graphically in Figure 32.

Results - The analysis of variance supports the conclusion that the 10 per cent dosing rate is more effective in producing higher recoveries. The dosing rate had an insignificant effect on the cake solids concentration. Comparing results of this test with those shown in Figure 31, the recovery and cake solids responses, within the dosing range of 0 to 40 lbs/ton, are very similar. It is interesting to observe that the electrophoretic mobility of the unsedimented particles in the centrate remained negative for the 10 per cent dosing rate. Since the Streaming Current Detector reading at this point was positive, the mobility determinations were probably in error.

Experiment 19

This experiment collected performance data during the start-up of the 24 x 60 inch centrifuge installed at St. Petersburg. A combination of adverse circumstances surrounding the start-up of this machine resulted in poor performance.

Results - Polymer demands were excessively high due to (1) operating under a surging pool condition caused by an oversize sludge feed pump; (2) operating at a pool depth less than maximum; and (3) poor dewatering characteristics of the sludge. The data collected during these tests are not included in this study.

After replacement of the sludge feed pump, the data taken during October, 1967, by Bird Machine Company are shown in Figure 33. Each response plotted on the graph represents one sample (no replicates). The

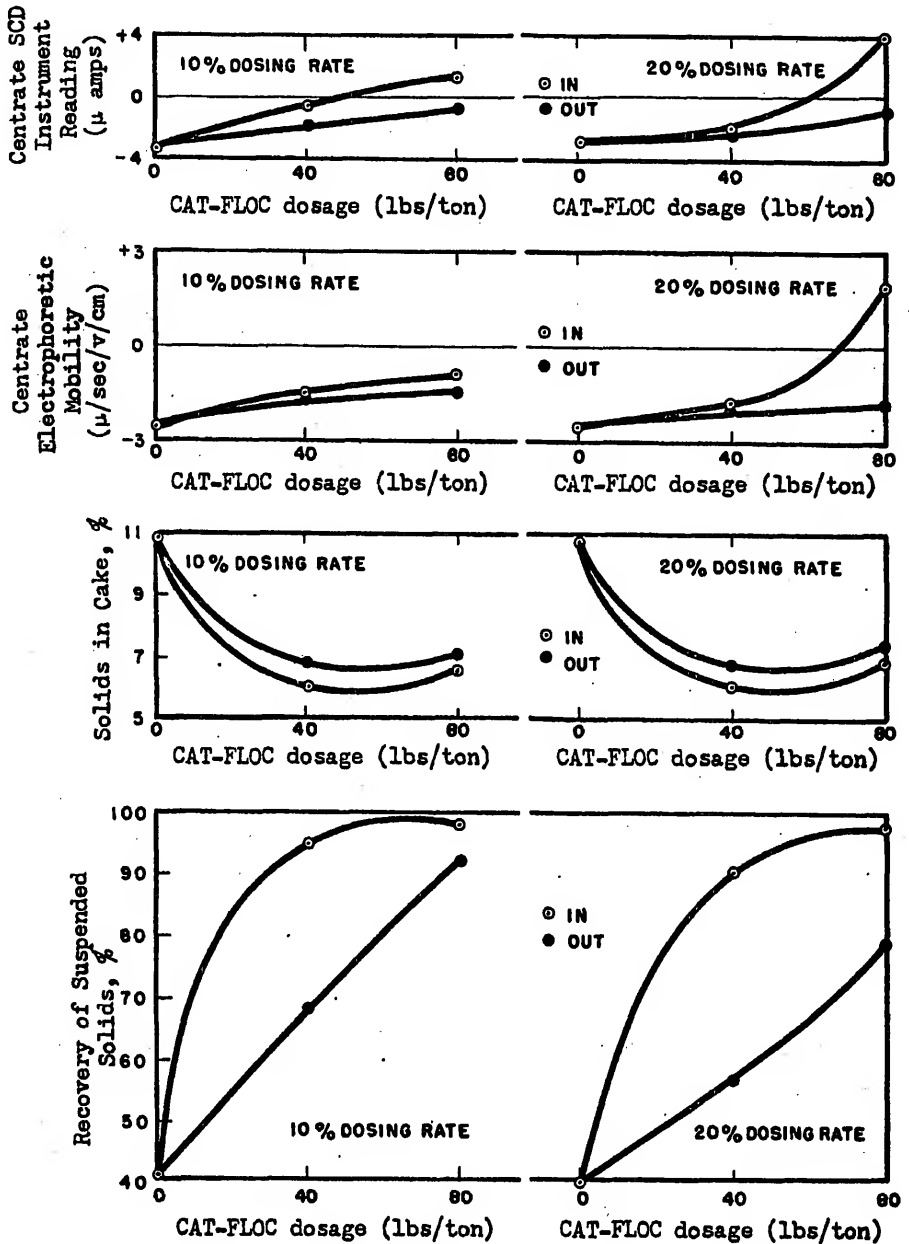

Fig. 32 - Effect of Polymer Dosage, Polymer Dosing Rate, and Location of Polymer Addition on Performance of 6x12 Inch Centrifuge De-watering Waste Sludge, St. Petersburg, Fla.

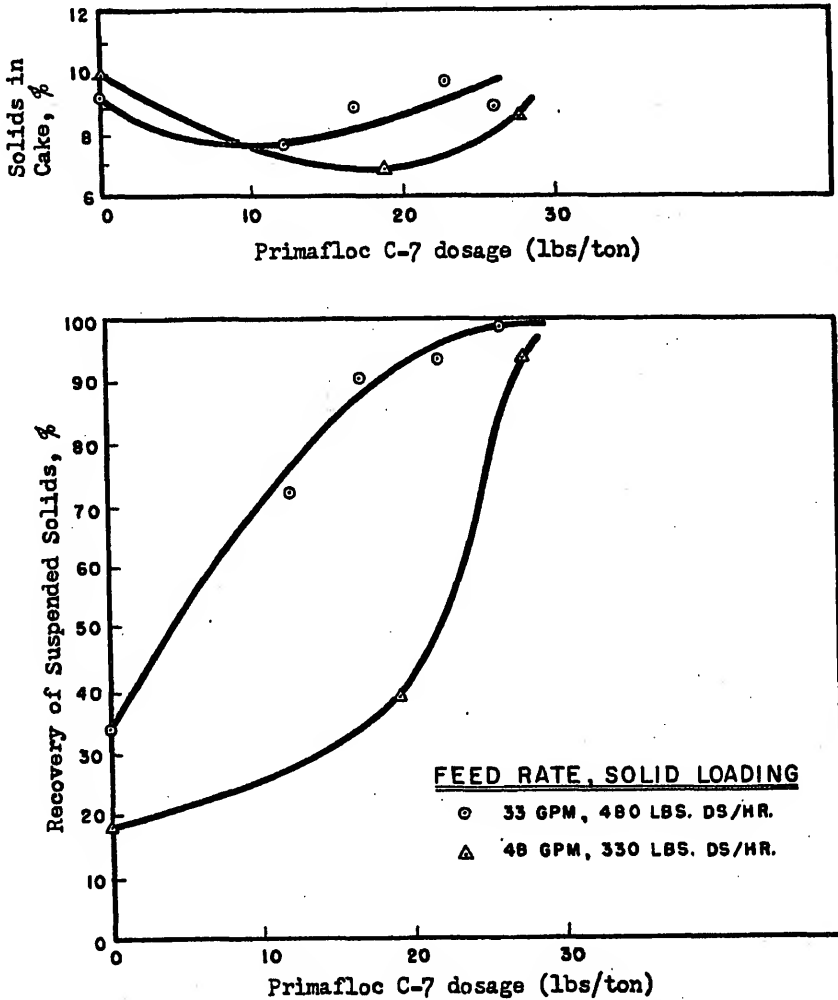

Fig. 33 - Performance of 24 x 60 Inch Centrifuge Dewatering Waste Sludge, St. Petersburg, Fla.

Centrifuge operation: 1,350 x gravity, deep pool setting No. 2.

Feed properties: Waste sludge high rate activated aeration.
SS = 2.8% at 33 gpm; 2.0% at 48 gpm.

Polymer addition: Dosing rate 9 gpm within centrifuge.

feed was sampled at the same time that the centrate and cake samples were taken and this explains the difference in the average suspended solids concentration at the different feed rates.

Experiment 20

This experiment determined the effect of polymer dosage and dosing rate on dewatering return activated sludge with the 24 x 60 inch centrifuge. The experiment was designed as a completely randomized block. The range of the polymer dosing rate was from 2 to 20 per cent of the sludge feed rate. The importance of the polymer dosing rate is clearly indicated in Figure 34.

Results - A dosing rate of 10 per cent of the sludge feed rate was best, producing maximum recovery and driest cake simultaneously.

Experiment 21

Since the 24 x 60 inch machine was operating at less than its maximum capacity of 400 lbs/hr in the previous experiment, another experiment was designed to determine the effect of feed rate, pool depth, and polymer dosing rate. This experiment was designed as a split-plot and Figure 35 shows the results.

Results - (1) Among the variables of this experiment only the feed rate and polymer dosage interact. Hence, dosing rate is independent and its effect is highly significant at the 1 per cent level.

(2) Figure 35 shows the response at 60 gpm to be about the same as in the previous test illustrated in Figure 34. However, an unusual and important phenomenon occurs at higher feed rates. Recovery and machine equilibrium is apparently disturbed by low polymer dosage in a dilute

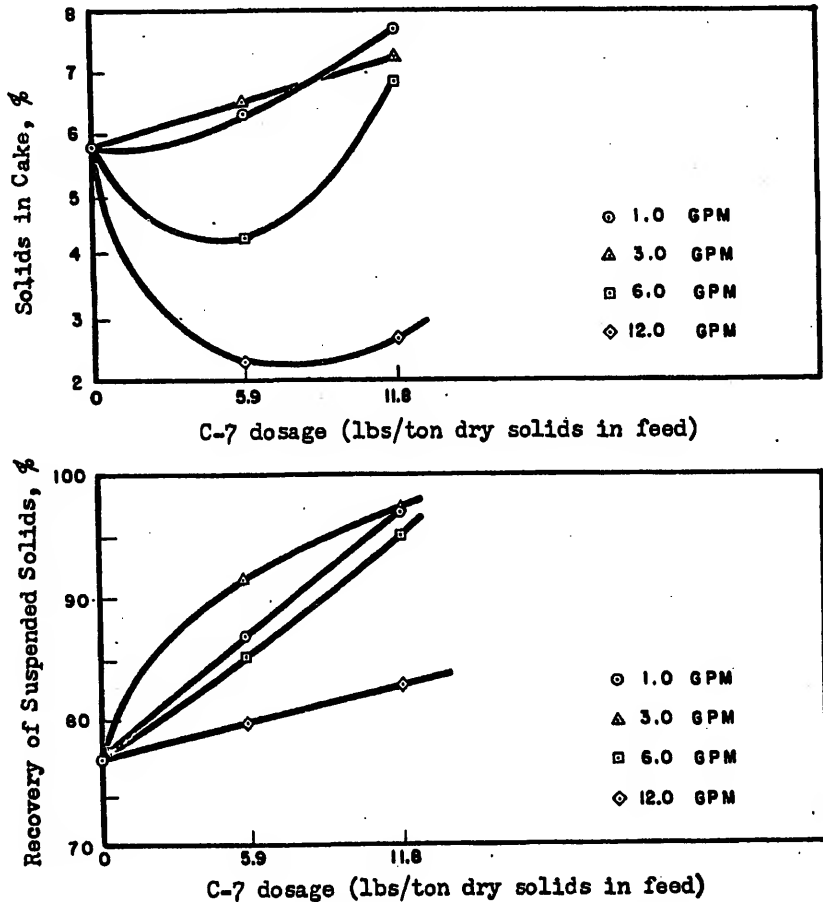

Fig. 34 - Effect of Polymer Dosage and Polymer Dosing Rate on Performance of 24 x 60 Inch Centrifuge Dewatering Return Activated Sludge, St. Petersburg, Fla.

Centrifuge operation: 1,350 x gravity; deep pool setting No. 3 1/4. Sludge feed rate 60 gpm, 300 lb. D.S. per hour.
Feed properties: High rate activated aeration return sludge. SS = 0.85%; pH = 7.1; SVI = 117; alkalinity = 401.
Polymer addition: Within centrifuge.

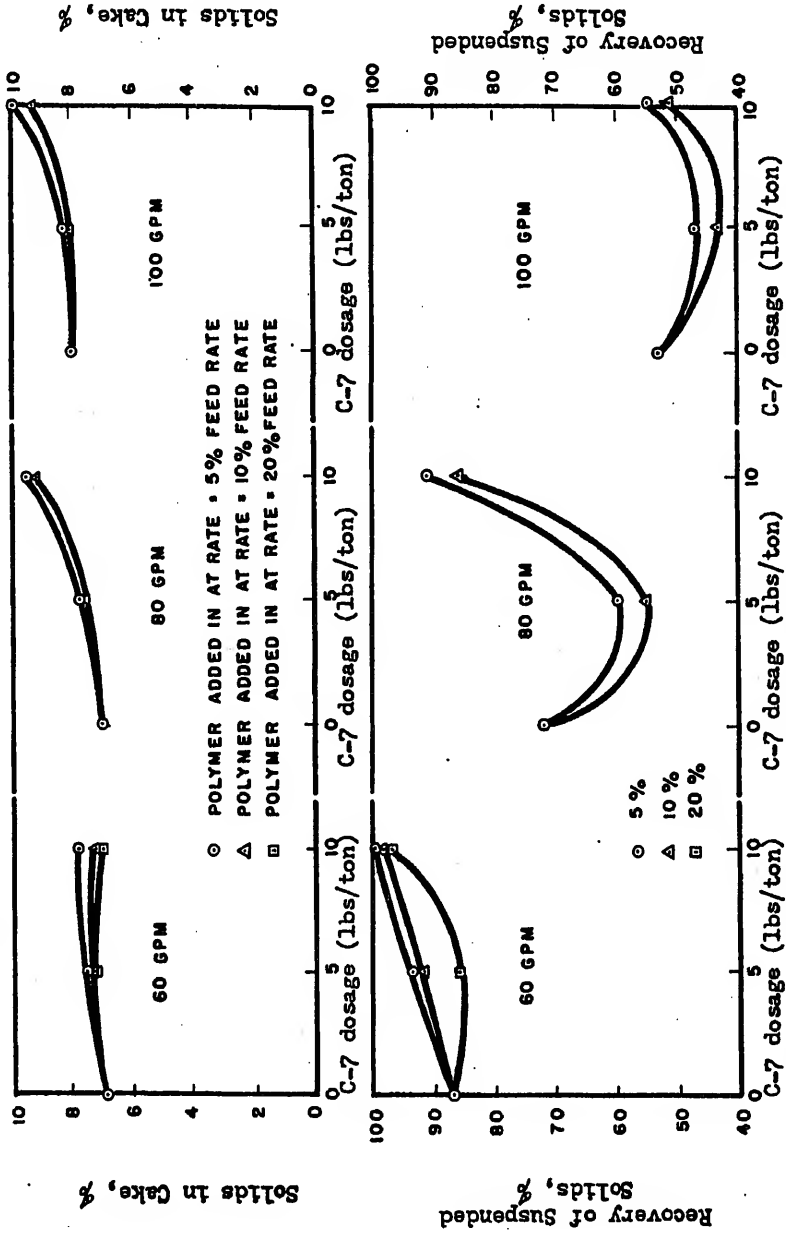

Fig. 35 - Effect of Polymer Addition Rate, Sludge Feed Rate, and Polymer Dosage on Performance of 24 x 60 Inch Centrifuge Dewatering Return Activated Sludge, St. Petersburg, Fla.

Conditions: 1,350 x gravity; pool set No. 3 1/2; SS = 0.77%; SVI = 110.

concentration. The effect is more pronounced at the higher dosing rates. Apparently, the jet action of the polymer being discharged through the nozzles into the pool resuspends settled sludge and the polymer dose is insufficient to capture the dispersed solids. The solids feed rate at 100 gpm is 385 lbs/hr and 300 lbs/hr at 80 gpm. Both of these are within the design capacity of the machine; therefore, the hydrodynamic effect must be responsible for the decrease in recovery. Retention time for the feed is reduced to 22 seconds at 100 gpm; not sufficient for floc settling to take place.

Dewatering Raw Sludge

The results of experiments on dewatering raw sludge are shown in Figures 36 and 37. The variables investigated and the responses observed are summarized in Table 8.

Experiment 22

This experiment was designed to determine the effect of sludge feed rate and polymer dosage on recovery of suspended solids and cake solids concentration when dewatering raw sludge. This experiment was designed as a split-plot.

Results - The results of this experiment are considered anomalous because the raw sludge suspended solids concentration was reduced by more than 50 per cent when screened prior to centrifuging in the 6 x 12 inch machine. Figure 36 shows the high polymer demand necessary to remove the suspended solids remaining in the sludge. Table 9 includes the results obtained with various polymers in the centrifuge to dewater raw sludge. The cationic polymers were the most effective. As a result of the problems

Table 8
Summary of Raw Sludge Experiments

Experiment Number	Data Table Number	Centrifugal Force	Pool Depth	Sludge Feed Rate	Sludge Concentration	Polymer	Polymer Dosage	Polymer Dosing Rate	Location Polymer Added	Recovery	Solids in Cake	Centrate Mobility	Centrate SCD Reading	**	
														A	B
22	33	X	X	X	X	X	X	X	O	O	O			A	1
23	34		X			X			O	O	O			B	2

* Centrifuge A = 6x12 in. B = 24x38 in. C = 24x60 in.
 ** Location 1 = Univ. of Fla. 2 = Treasure Island 3 = St. Petersburg

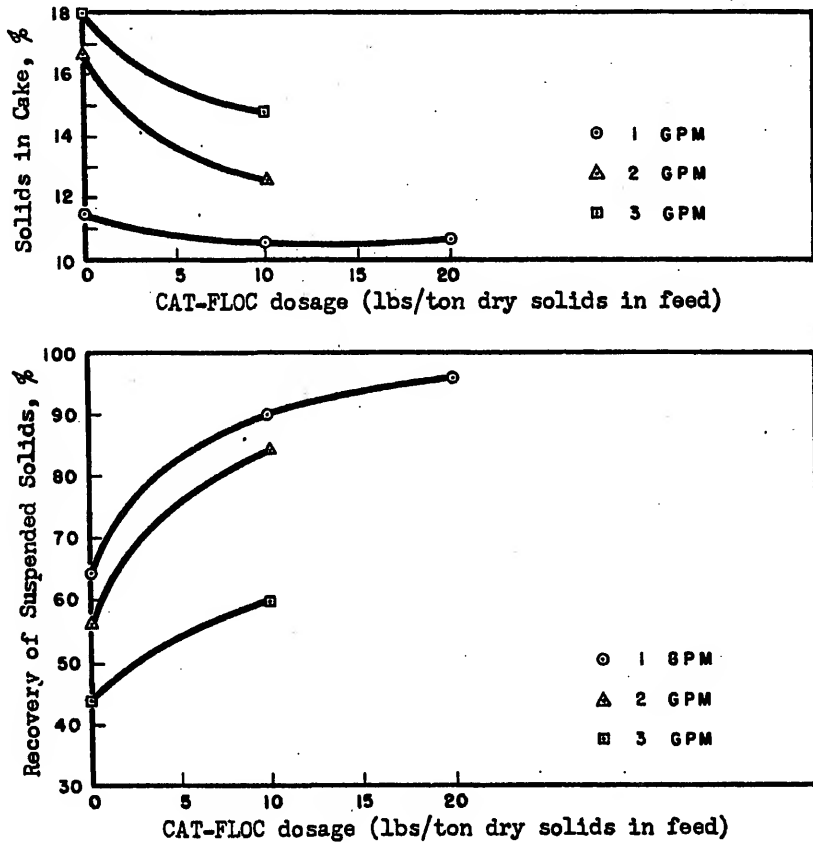

Fig. 36 - Effect of Sludge Feed Rate and Polymer Dosage on Performance of 6x12 Inch Centrifuge Dewatering Raw Sludge, University of Florida.

Centrifuge operation: 1,180 x gravity; deep pool (0.594 in).
Feed properties: SS = 0.38%; VSS = 80.68%; alkalinity = 67.
Polymer addition: Dosing rate 10% of sludge feed rate within centrifuge.

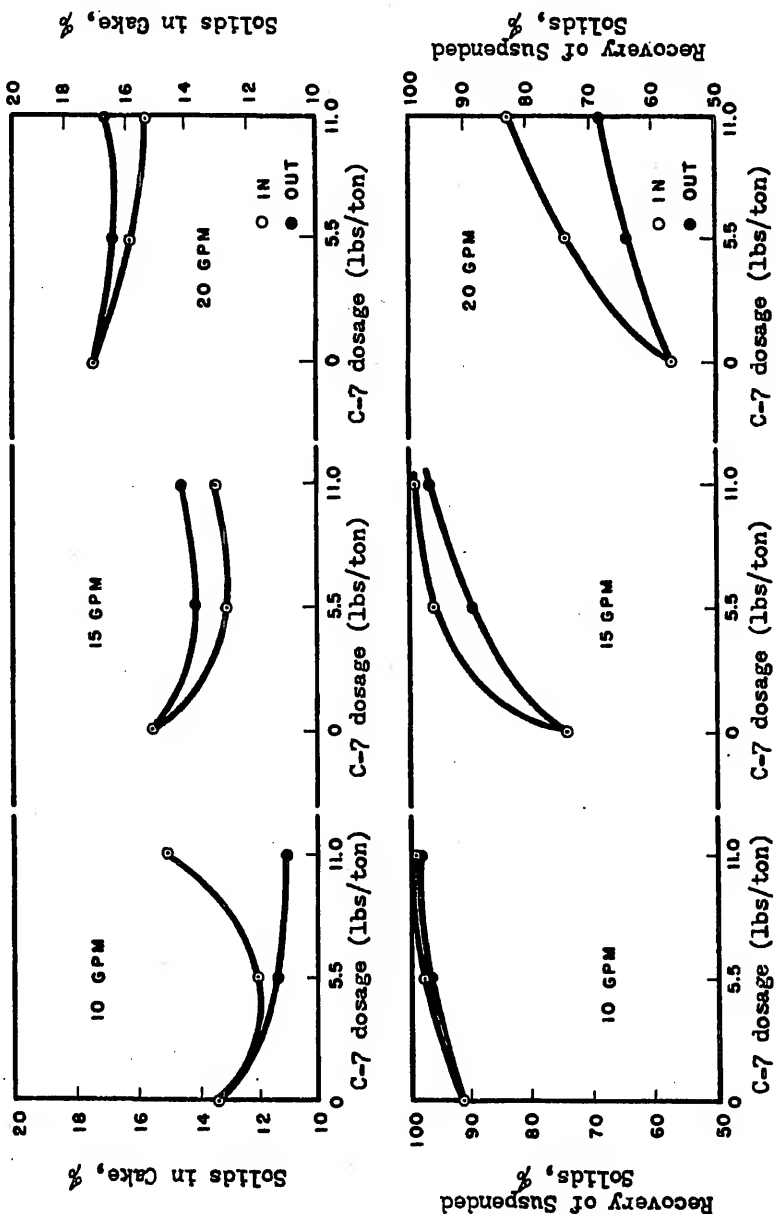

Fig. 37 - Effect of Feed Rate and Polymer Dosage on Performance of 24 x 38 Inch Centrifuge Dewatering Raw Sludge, Treasure Island, Fla.

Conditions: 1,335 x gravity, deep pool, feed SS = 4.56%.

Table 9

Effect of Anionic and Cationic Polymers on Dewatering Raw Sludge at the University of Florida Sewage Treatment Plant

Feed Rate (gpm)	Polymer	Polymer Dosage (lbs/ton)	Recovery of Suspended Solids Per cent	Cake Solids Per cent	Centrate Electro-phoretic Mobility (μ /sec/v/cm)
1	None	0	50.76	11.83	-1.6
			69.26	11.28	--
	Purifloc A-21	5	76.41	11.04	-1.8
			80.78	10.96	--
			77.68	11.68	-1.6
	CAT-FLOC	10	74.47	12.04	--
			90.47	10.47	-1.1
	CAT-FLOC	20	89.95	10.16	--
			96.71	10.80	+2.5
	Purifloc C-31	10	92.59	11.64	--
			91.79	10.78	0.0
	Purifloc C-31	20	91.29	10.72	--
			91.11	12.03	+0.9
	Prima-floc C-7	3.3	91.05	12.10	--
91.89			13.56	-0.4	
Prima-floc C-7	6.6	90.68	12.59	--	
		92.50	10.93	+1.0	
Prima-floc C-7	6.6	93.57	10.56	--	
		CAT-FLOC	0	60.76	11.83
69.26	11.28			--	
90.47	10.47			--	
CAT-FLOC	10	89.95	10.16	--	

Table 9 - Continued

Feed Rate (gpm)	Polymer	Polymer Dosage (lbs/ton) *	Recovery of Suspended Solids Per cent	Cake Solids Per cent	Centrate Electrophoretic Mobility (μ /sec/v/cm)
2	CAT-FLOC	0	56.18	16.52	--
			55.78	16.68	--
		10	84.25	12.58	--
			83.46	12.45	--
3	CAT-FLOC	0	40.12	18.13	--
			45.89	17.75	--
		10	63.84	14.62	--
			55.77	14.94	--

* Polymer dosage in pounds per ton dry solids in feed.

Centrifuge operation: Bird 6x12 inch continuous solid bowl centrifuge with countercurrent flow operating at a centrifugal force of 1,180 times gravity and a deep pool depth (0.594 inches).

Feed properties: Raw sludge.

Total solids =	0.51%	pH = 5.7	Alkalinity = 67
Suspended solids =	0.38%	Temperature = 86 ^o F	
Volatile solids =	80.68%	Electrophoretic mobility =	
		1.6 μ /sec/v/cm	

Polymer addition: Polymers were added within centrifuge liquid pool at 10% of the sludge feed rate.

experienced in dewatering raw sludge with a 6x12 inch machine, the necessary equipment was taken to Treasure Island, Florida, to accomplish the work on the 24 x 38 inch centrifuge.

Experiment 23

The experiment to dewater raw sludge with the 24 x 38 inch machine at Treasure Island was designed as a randomized block. The variables evaluated were feed rate, polymer dosage, and location of polymer added. The curves in Figure 37 show the effect of these variables on recovery of suspended solids and cake solids concentration.

Results - (1) The sludge feed rate had the single greatest effect on recovery of the suspended solids.

(2) By adding polymer within the centrifuge, high recovery and a substantial increase in solids content in the cake was achieved.

(3) The most remarkable characteristic about dewatering raw sludge by centrifugation was the high recovery efficiency accompanying no or low polymer dosages.

Discussion

Machine and Process Variables

The most important characteristic of raw, activated, or digested sludge is the operating line showing the relation between throughput rate and proportion of the feed solids sedimented. The other important feature of a sludge is the dryness that can be achieved in the discharged cake solids. Aside from the nature of the sludge, there are both mechanical and process variables that can be controlled to combine satisfactory clarity and solids dryness.

The mechanical variables investigated in this study that affect clarification were bowl speed and pool depth. Higher speed contributed greatly to the capability of the centrifuge to dewater digested sludge, but an intermediate range was more effective for the light, more flocculant activated sludges. According to theory, a shallow pool should give the best clarification. This is not true in practice due to non-theoretical inefficiencies. For example, thin liquid layers mean high linear flowthrough velocities and the conveyor-bowl differential rotation tends to redisperse settled solids. In the countercurrent machines the feed zone turbulence also resuspends solids previously sedimented. Consequently, increasing the pool depth increased recovery performance.

In regard to cake dryness these same variables operate in somewhat different fashion. For example, with a shallower pool depth in the centrifuge, the cake solids are transported over a longer drying deck and they can drain more completely. The coarser solids obtained at lower recovery efficiencies drained rapidly but the fine solids captured by polymer addition or low feed rate produced a more uniformly graded cake, filled the voids, and did not drain at all. Drying was attributed to compaction. Only by polymer treatment could the recovery be increased and a drier cake obtained. A shallow pool was unsatisfactory for the activated sludges, since the cake could not be conveyed to the discharge outlets.

Among the process variables, the primary one was the feed rate because it relates the required plant throughput to the number and size of centrifuges necessary to achieve the required effluent clarity and

cake dryness. The solids loading of the feed can affect both clarity and dryness; handling a larger volume of solids in the bowl means less retention time so there is a tendency toward wetter solids at the increased solids throughput for activated solids and the opposite for digested solids.

The dewatering characteristics of solids can be significantly changed by the introduction of polymer within the centrifuge. In general, it is not necessary to use flocculant aids unless high recoveries are necessary or both a high clarification and dry cake are required simultaneously.

The effect of these variables, both mechanical and process, on the three centrifuges used in this study can be well demonstrated by reference to a sedimentation performance curve. This empirical approach is the accepted method to compare clarification limitations of centrifuges operating on the same sludge.^{46, 49}

Sedimentation Performance Comparisons of Centrifuges

The sedimentation performance of the three centrifuges are illustrated in Figure 38. The ordinates show the proportion of suspended feed solids removed in the centrifuge; the abscissa is a generalized correlation for feed rate to the concentrate. The method of comparison is to divide the sludge feed rates for a given set of data by the pertinent capacity factor, Σ , for the centrifuge operating conditions. This produces a generalized correlation parameter, $\frac{Q}{\Sigma}$, for the capacity data taken at all the different centrifuging conditions. Tables 10 and 11 list the theoretical sigma values for the three centrifuges used in this

CENTRIFUGE C-7(LBS/TON) PLANT

○	6 X 12	0	TREASURE ISLAND
●	6 X 12	10	TREASURE ISLAND
△	24 X 38	0	TREASURE ISLAND
▲	24 X 38	10	TREASURE ISLAND
□	24 X 60	0	ST. PETERSBURG

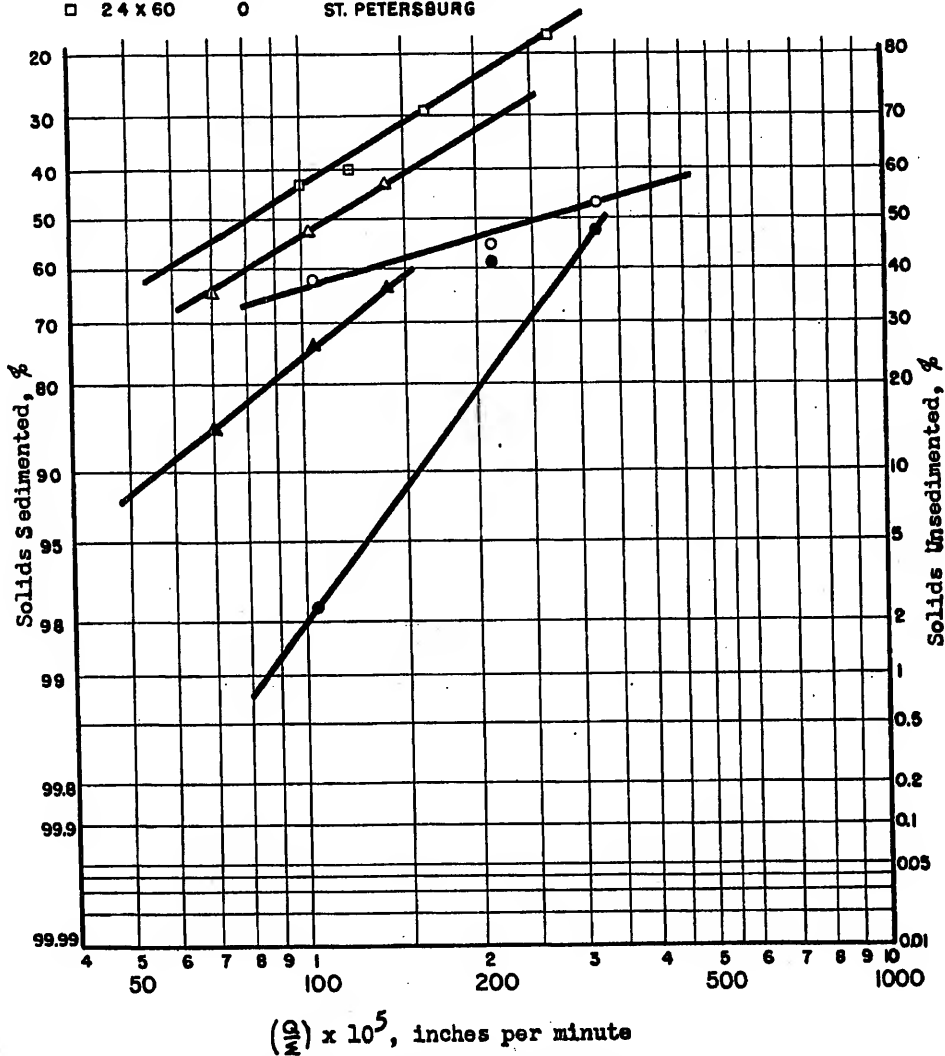

Fig. 38 - Sedimentation Performance Versus Parameter $\frac{RPM}{min}$ for Bird Solid Bowl Centrifuges Dewatering Digested Sludge.

Table 10

Sigma Values and Volumes for Three Centrifuges Used^{a, b}

Centrifuges	6 x 12			24 x 38		24 x 60
Pool depth, in.	0.594	0.422	0.250	1.375	2.375	2.500 ^c
l, inches	7.89	7.89	7.89	25.75	25.75	42.75
l ₂ , inches	3.25	2.27	1.30	9.00	12.25	16.00
l, inches	12.10	12.10	12.10	38.00	38.00	58.75
r, inches	3.00	3.00	3.00	12.00	12.00	12.00
r ₂ , inches	2.41	2.58	2.75	10.63	9.63	9.50
Σ	1.41ω ²	1.35ω ²	1.28ω ²	74.84ω ²	75.46ω ²	118.12ω ²
N, rpm	3750	3750	3750	2000	2000	2000
ω, radius/sec.	392.25	392.25	392.25	209.33	209.33	209.33
ω ²	0.44x10 ⁵	0.44x10 ⁵	0.44x10 ⁵	0.44x10 ⁵	0.44x10 ⁵	0.44x10 ⁵
Σ, sq. in.	2.16x10 ⁵	2.08x10 ⁵	1.96x10 ⁵	32.78x10 ⁵	33.05x10 ⁵	51.73x10 ⁵
V, volume in gal.	0.415	0.288	0.168	12.85	22.26	37.08

Equations:

$$\Sigma = \frac{2\pi\omega^2 l_1}{g} \left(\frac{3r_1^2 + r_2^2}{4} \right) + \frac{2\pi\omega^2 l_2}{g} \left(\frac{r_1^2 + 3r_1 r_2 + 4r_2^2}{8} \right)$$

$$\omega = \frac{2\pi N}{60}$$

^aNo corrections applied for volume occupied by scroll or solids being conveyed.

^bDimensions were scaled from Assembly Drawings of the respective centrifuges:

- 6 x 12 - Drawing PBL-140Y
- 24 x 38 - Drawing LBA1-917Z
- 24 x 60 - Drawing LBA1-1243

^cPool setting number 3 1/2.

Table 11

Sigma Values in Square Inches for 6x12 Inch Centrifuge^a

Machine Speed rpm	Pool Depth, Inches		
	0.594	0.422	0.250
2830	1.23×10^5	1.18×10^5	1.12×10^5
3750	2.16×10^5	2.08×10^5	1.96×10^5
5810	5.19×10^5	4.98×10^5	4.71×10^5

^aNo corrections applied for the volume occupied by scroll or solids being conveyed.

study. The sigma values have not been corrected for the five disturbing factors discussed in Chapter III. The corrected values for Σ are proprietary information of Bird Machine Company.

Comparison of 6x12 and 24x38 Inch Centrifuges

Digested sludge - The curves shown in Figure 38 show the sedimentation performance characteristics obtained experimentally for the 6x12 and 24x38 inch machines dewatering the same anaerobically digested sludge at Treasure Island. The effect of feed rate on the performance of two centrifuges dewatering the same sludge and the effectiveness of polymer addition to increase recovery are shown in Figures 23 and 24. If the efficiency of the 6x12 inch is taken as 100 per cent, an efficiency factor for the 24x38 inch centrifuge may be computed from these experimental results.

Sedimentation performance of any two similar centrifuges treating the same sludge will be the same if the Q/\underline{z} has the same value for each. In practice, the introduction of an efficiency factor, e , is necessary to make possible the extension of the use of \underline{z} to comparisons involving dissimilar centrifuges. The factor e takes into consideration the different levels of turbulence, remixing, etc., which exist in different centrifuges even when operating on the same feed material. For equal performance, the following applies:

$$Q_2 = \frac{e_2 \underline{z}_2}{e_1 \underline{z}_1}$$

For the 6 x 12 inch operating at 1 gpm, 1,180 times gravity, zero polymer and deep pool, the $(\frac{Q}{\underline{z}}) \times 10^5$ value is 107. The corresponding value for the recovery of the suspended solids was 61 per cent. The flowthrough rate for the 24 x 38 inch machine to achieve the same recovery is calculated as follows: $Q_2 = (1) \frac{(.83)(33)}{(2.16)}$ where $e_2 = 0.83$

$$Q_2 = 12.7 \text{ gpm}$$

This checks very close to the result obtained in Experiment 10 shown in Figure 24 where at 10 gpm the recovery was 63 per cent.

Return activated sludge - The 6 x 12 inch and 24 x 38 inch centrifuges are compared dewatering return sludge by the sedimentation performance curves shown in Figure 39. Once again the 6 x 12 inch machine outperformed the 24 x 38 inch machine at a given $\frac{Q}{\underline{z}}$ parameter. The 24 x 38 inch machine was approximately 60 per cent as efficient as the 6 x 12 inch machine. The machines are also compared with equivalent polymer dosages. The superior recovery of suspended solids in the 6 x 12

CENTRIFUGE POLYMER DOSAGE(LBS./TON)

○	6 X 12	0	
●	6 X 12	8.8	CAT-FLOC
△	24 X 38	0	
▲	24 X 38	3.0	C-7

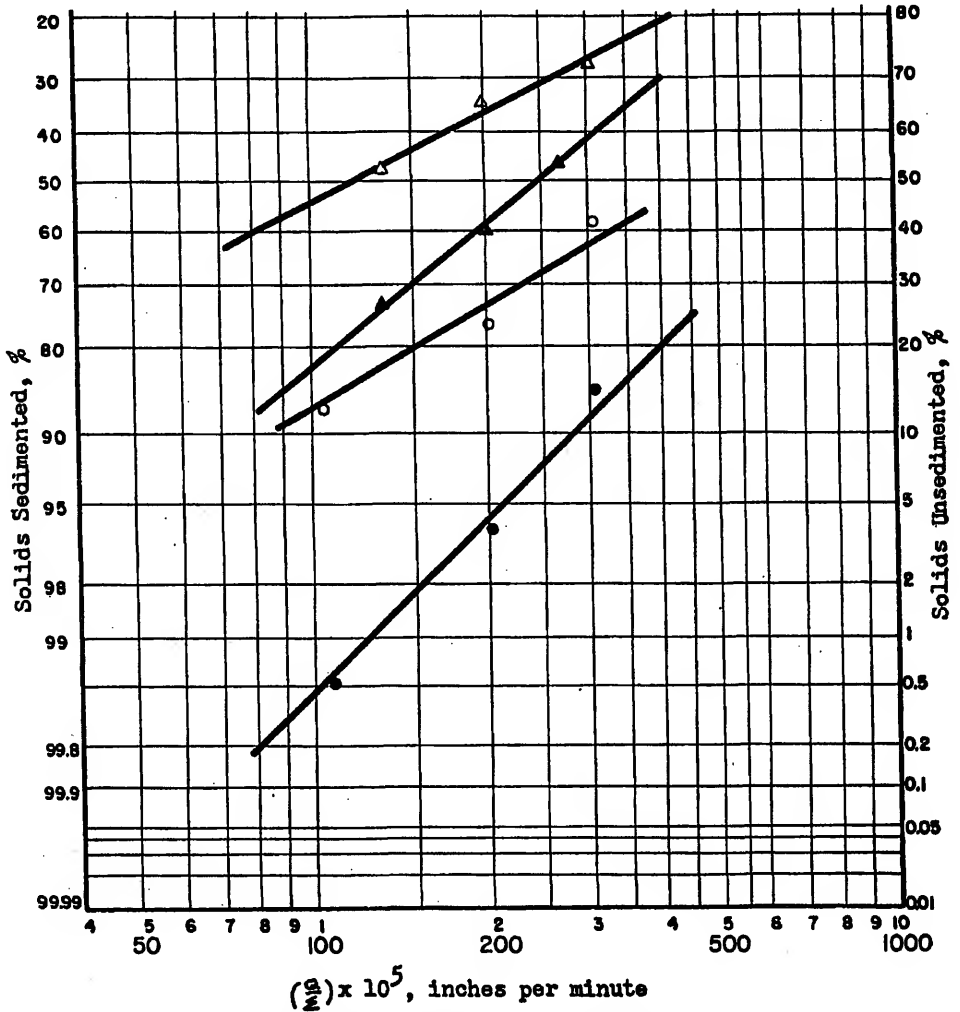

Fig. 39 - Sedimentation Performance Versus Parameter $\frac{g}{\text{min}}$ for Bird Solid Bowl Centrifuges Dewatering Return Activated Sludge, Treasure Island, Fla.

inch machine may be partly attributed to the small difference in SVI of the two sludges (105 and 115). The data from which the comparison is made are shown in Figures 29 and 30.

Comparison of the 6 x 12 and 24 x 60 Inch Centrifuges

Dissimilar types of centrifuges operating on the same feed may be compared if the efficiency factors are known. Figures 40 and 41 show the performance characteristics obtained experimentally for the 6 x 12 and 24 x 60 inch centrifuges dewatering the same waste sludge at St. Petersburg, Florida. The 6 x 12 inch machine is compared at three levels of centrifugal force. Clearly, losses are high for this sludge as the material was difficult to settle and difficult to convey. The 6 x 12 inch machine was operated at 1 and 2 gpm while the 24 x 60 inch machine was operated at 33 and 48 gpm. The curves show once again that the performance of the 6 x 12 inch machine performs very closely to that of the 24 x 60 inch machine for any given $\frac{Q}{M}$ factor, but the important point is that the capacity of the 24 x 60 inch centrifuge is approximately 25 times that of the 6 x 12 inch machine, according to this method of comparison.

The comparison of the three centrifuges on the basis of theoretical capacity factors alone may not be practical; ⁴⁷ nevertheless, the \leq concept has proved itself a valuable tool in the past ⁴⁷ and in this case lends support to the conclusion that the work done in this study with the 6 x 12 inch centrifuge predicts the performance of larger machines. The 6 x 12 inch always outperformed the larger machines at a given $\frac{Q}{M}$ parameter in these limited number of tests. Certainly, more testing should be accomplished to determine the efficiency factors and the reliability

CENTRIFUGE POOL DEPTH POLYMER DOSAGE(LBS./TON)

○	6 X 12	0.594"	0	
●	6 X 12	0.594"	50	C-31
■	24 X 60	NO.4	0	
◇	24 X 60	NO.2	0	
◆	24 X 60	NO.2	50	C-31

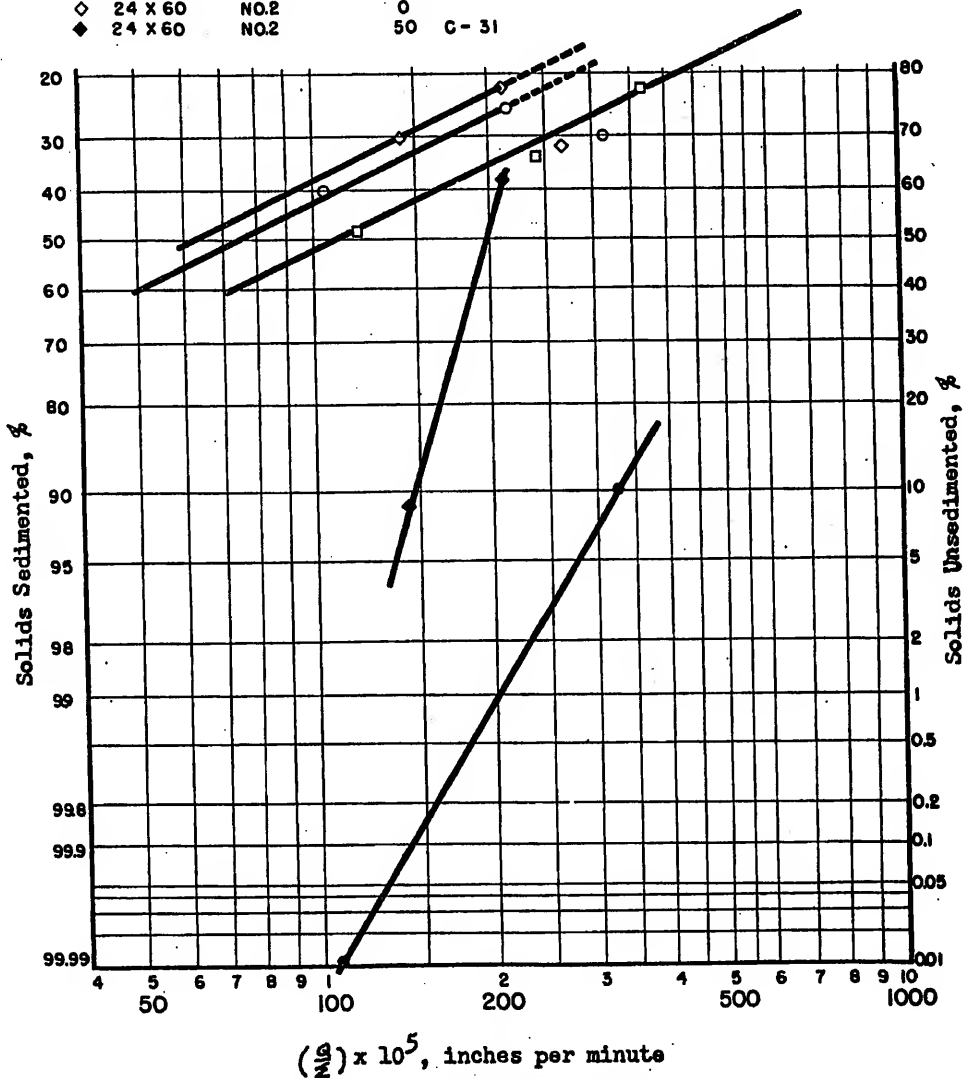

Fig. 40 - Sedimentation Performance Versus Parameter $\frac{G}{M}$ for Bird Centrifuge Dewatering Waste Sludge, St. Petersburg, Fla.

CENTRIFUGE	G. FORCE	POLYMER DOSAGE
○	6 X 12 AT 2880 X G.	0
●	6 X 12 AT 2880 X G.	10 LBS/ T. CAT-FLOC
⊙	6 X 12 AT 2880 X G.	50 LBS/ T. CAT-FLOC
△	6 X 12 AT 680 X G.	0
▲	6 X 12 AT 680 X G.	10 LBS/ T. CAT-FLOC
▴	6 X 12 AT 680 X G.	50 LBS/ T. CAT-FLOC
□	24 X 60 AT 1350 X G.	0
■	24 X 60 AT 1350 X G.	50 LBS/ T. C-31

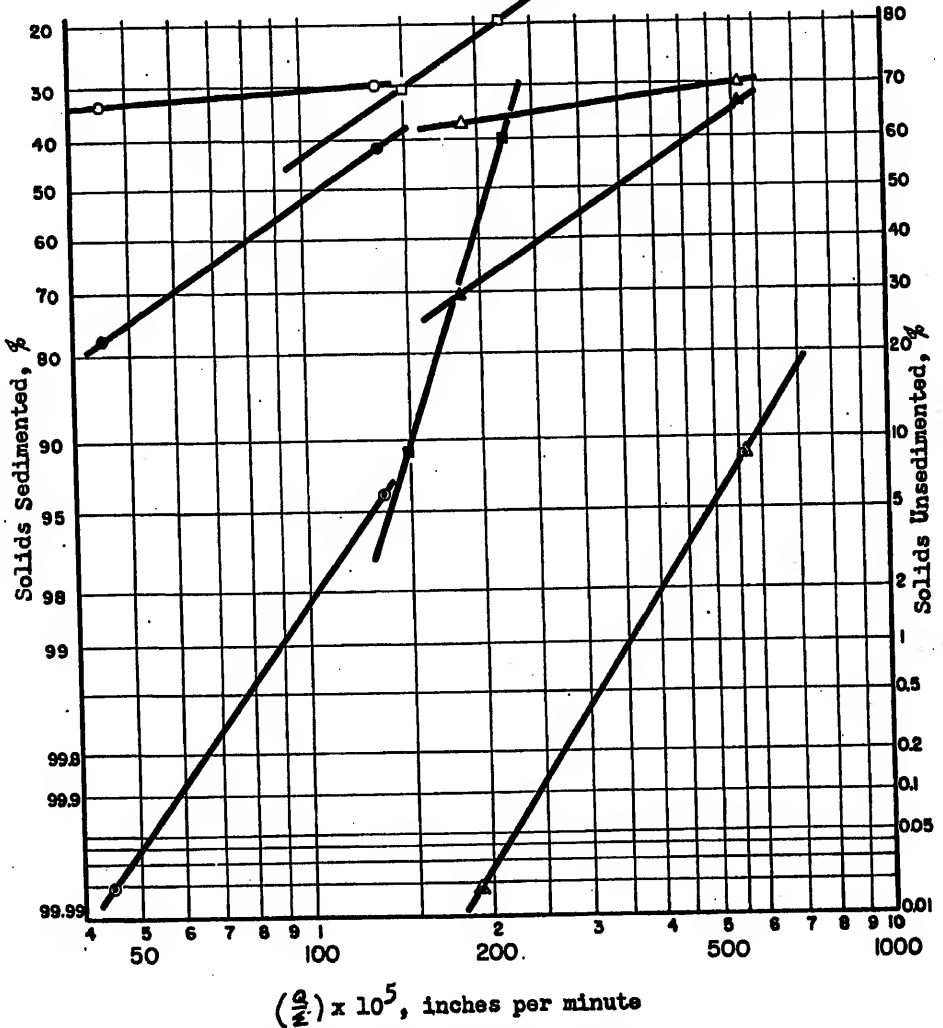

Fig. 41- Sedimentation Performance Versus Parameter $\frac{M/D}{\text{min}}$ for Bird Solid Bowl Centrifuge Dewatering Waste Sludge, St. Petersburg, Fla.

of scaling-up from results of tests conducted with the 6 x 12 inch centrifuge.

The testing and scaling-up problem for this type of machine is made especially complicated by the many, apparently minor, design variations that have to be made to the machine for each different application. Experience with this type of equipment has shown, however, that such changes have a disproportionately great influence on performance.⁴⁶

Characteristics of Sludges Dewatered

Raw, activated, and digested domestic waste sludges exhibited distinct dewatering characteristics, enough to justify the generic grouping in this study. From treatment plant to treatment plant, the three generic groups of sludges exhibited similar dewatering characteristics and laboratory determinations of their initial properties substantiated the groups as similar from plant to plant.

Digested sludges - No discernible difference in character can be distinguished from the analysis of volatile solids, pH, and alkalinity.

Activated sludge - The dewatering characteristics of the five different activated sludges centrifuged in this study were closely associated with their settleability. Those which were difficult to dewater were bulky and had a sludge volume index greater than 200. Heukelekian determined that the bound water content increases as the sludge volume index increases.⁸⁷ This hydrophilic property of activated sludge accounts for the increased difficulty in dewatering and explains the reason why particle charge reduction is necessary but not sufficient in improving dewatering.

Raw sludge - At the two treatment plants where raw sludge was dewatered, there was no discernable difference between the volatile solids, pH, and alkalinity of the sludge.

Laboratory Tests

Polymer flocculation, Buchner funnel, clinical centrifuge, and sludge volume index tests on the sludge prior to centrifugation provided a qualitative estimate of the sludge dewatering characteristics and the effectiveness of polymer conditioning.

Polymer flocculation - The relative polymer dosage and reaction time to form a floc was readily determined. The basis of polymer selection was: (1) nearly instantaneous floc formation, and (2) high degree of separation into distinct agglomerated flocs and a clear suspending liquid. The settling rate was not important as the more concentrated sludges did not settle or subside even though they were highly flocculated.

Clinical centrifuge test - Spinning the sludge with and without polymer treatment in a clinical centrifuge established qualitatively the compacting character of the settled sludge. Polymer dosage was less than required in solid bowl machines for a clear supernatant. This test was of no value in estimating the ease of the sludge to be dewatered.

Buchner funnel test - The Buchner funnel test was the most reliable to predict the ease or difficulty of dewatering a sludge. The polymer dosages required for a minimum specific resistance was usually twice the polymer dosage required for recoveries exceeding 90 per cent in the centrifuge.

Sludge volume index test - Determination of the sludge volume index

was the fastest and most reliable estimate of dewatering characteristics of activated sludges. The lower the sludge volume index, the easier the centrifugal separation.

More quantitative results could not be devised to reflect the conditions in the centrifuge during dewatering. The laboratory tests did establish the dewatering characteristics of the sludge and gave an estimate of polymer dosage required for clarification of the centrate. The laboratory techniques used in this research are used by others as the first preliminary objective test for determining the practicality of centrifugal separation and for equipment screening when a solids-liquid separation is required.⁴⁹

Polymer Dosage

In this study the cationic polyelectrolytes were more effective for flocculating all three types of sludge. Flocculant solution strengths investigated ranged from 0.02 per cent to 1.0 per cent polymer by weight as received from the manufacturer with dosages ranging from 0.05 per cent to 4.0 per cent by weight of the dry solids in the feed sludge. Recovery improved as dosage continued to increase until nearly 99 per cent recovery of suspended solids was achieved; additional polymer began to re-suspend the solids in the centrate. The amount of polymer dosage required to recover the last 5 per cent of the feed solids doubled and even tripled, indicating that recoveries in excess of 95 per cent are not practical in most cases. The effectiveness of the polymer was directly related to the detention time of the feed slurry within the centrifuge which was controlled by the feed rate.

The effectiveness of a given polymer dosage to improve recovery was decreased as the sludge concentration increased. In a sludge slurry where interparticle collisions are not the limiting factor, the amount of polymer adsorbed by the sludge was dependent upon the number of adsorption sites and a minimum dosage was required for effective flocculation. Tenny and Stumm⁸⁸ have found a stoichiometric relationship between the amount of polymer required to cause flocculation and the number of microorganisms in suspension. They reported that the amount of polyelectrolyte required to cause flocculation was in the order of 20 μ g/mg of cell dry weight. (This was equivalent to a polymer dosage of 2 per cent of the dry feed solids or 40 lbs/ton dry solids). They further stated that this amount appears to be only a fraction of that which can be ultimately adsorbed. It is not surprising that dosages in the range of 2 per cent are required for effective flocculation in the centrifuge. Extensive work with solids-liquid separation by Jones⁷⁴ showed that optimum suspended solids removal occurred at a CAT-FLOC polymer dosage between 2 and 3 per cent of the dry suspended solids.

The hydrophilic character of the sludge accounts for the fact that particle charge reduction is not sufficient for flocculation and dewatering. Solids-liquid separation is the result of electrostatic forces bonding positively charged segments of the polymer to the microbial surface and bridging the particles together by the mechanical action of the polymer chain extending from one or more adsorbed sites on the particle. As functional sites are neutralized, the polymer chain begins to kink and coil again pulling the floc together into large, dense particles which

can be more readily separated by centrifugal force.

The effect of excess cationic polymer was one of partial restabilization of the particles accompanied by a decrease in recovery efficiency, but a continued increase in cake solids concentration. The excess polymer enabled further compaction and expulsion of water from the fine settled solids. The polymer, acting as a hydrating salt, competed for the bound water, and the centrifugal force mechanically expelled the water by compaction. Primafloc C-7 polyelectrolyte was more effective than the other polymers used in decreasing the moisture content of the cake. When C-7 was used this phenomena began to increase cake solids concentration simultaneously as recovery continued to increase after approximately the 80 per cent recovery level was achieved.

Centrate Mobility, SCD Readings, and Residual Polymer

A method was sought to determine the efficiency of polymer utilization and to aid in explaining the dewatering mechanism. Since the instability of colloids are related to particle charge and water of hydration, it was decided to sample the centrate and thereby estimate the particle zeta potential by determining its electrophoretic mobility. The method was subject to some question since the properties of the flocculated particles at the time of collection of a sample were not necessarily those that were determined several hours later. Streaming current measurements made at the same time the electrophoretic mobility determinations were made, provided a means of rapidly determining the sign and electrical charge density on the preformed flocs. In this way the surface properties of the flocs were studied. The correlation between the mobility

of the filtered samples and the SCD reading of the unfiltered samples was good. The trends followed by each were closely reproduced.

Interpretation of the results were confounded by the presence of a few unusual observations such as high recovery and an average centrate particle mobility of high negativity. Generally, the trend of both the SCD and mobility readings showed that as the particle charge was reduced toward zero and even reversed, centrate clarification improved.

Residual CAT-FLOC determinations were subject to the same error as mobility and streaming current determinations, i.e., continued polymer adsorption by centrate particles after sample collection. The results of electrophoretic mobility, Streaming Current Detector readings, and residual polymer tests indicated that particle charge reduction played an important part in improving the centrifugal dewatering of sludges, but sludge feed rate, pool depth, location of polymer addition, and centrifugal force could readily override the benefit derived from conditioning the sludge with polyelectrolytes.

In conclusion, high polymer dosages were required to achieve high recovery efficiencies and cake dryness simultaneously. Further advances in the technology of sludge dewatering hinge on the elucidation of the coagulation and flocculation mechanisms involved in sludge conditioning to produce a readily dewaterable sludge.

CHAPTER VI

CONCLUSIONS

A thorough study has been made of dewatering domestic waste sludges using three different solid bowl, continuous centrifuges with and without the addition of polyelectrolytes. The purpose of the study was to determine the effect and interaction of the machine and process variables on both recovery of suspended solids from feed sludge and the concentration of the cake solids discharged. The effects of the following machine and process variables were evaluated: centrifugal force, pool depth, sludge feed rate, sludge concentration, polymer, polymer dosage, polymer dosing rate and location of polymer addition. The general effect of each variable can be summarized in the following statements, with the understanding that the variables were highly interdependent. The following effects hold if all the other variables are held constant.

1. As centrifugal force increased:
 - (a) recovery of suspended solids increased for digested and raw sludges,
 - (b) concentration of cake solids increased for all three sludges. (linearly)
2. An intermediate centrifugal force increased recovery of suspended solids for activated sludge.
3. As pool depth increased:
 - (a) recovery of suspended solids increased for all sludges.

- (b) concentration of cake solids decreased for all sludges.
4. As the sludge feed rate increased:
- (a) recovery of suspended solids decreased exponentially for all sludges.
 - (b) cake solids concentration increased for raw and digested sludges.
 - (c) cake solids concentration decreased for activated sludge.
5. As feed sludge concentration increased the recovery of suspended solids decreased and cake solids concentration increased for all sludges.

Additional conclusions drawn from this study are:

1. Cationic polymers were found to be the most effective for flocculating and improving the sludge dewatering characteristics of all sludges.
2. Recovery of suspended solids was always more complete for all sludges when the polymer was added within the centrifuge as opposed to addition outside the centrifuge.
3. Polymer dosing rates at 5 to 10 per cent of the sludge feed rate were the most effective for improving recovery of suspended solids from raw, activated, and digested sludges.
4. Electrophoretic mobility and Streaming Current Detector determinations on the particles in the centrate showed that as recovery continued to improve the particle charge was reduced and approached zero. Reduction of particle electronegativity

was a function of polymer dosage. The dosage was directly related to the particle initial charge density.

5. Residual polymer determinations did not detect any polymer in the centrate for dosages applied up to 40 lbs/ton.
6. The desired results of high centrate clarity and high cake dryness require a compromise in the design and operation of the centrifuge for they cannot be achieved simultaneously.
7. Polyelectrolytes can improve the sedimenting characteristics of the solids and thereby improve centrifuge performance, but high dosages are necessary if a dry cake and clear centrate are desired.
8. Sedimentation performance comparisons between the 6 x 12 inch centrifuge and the 24 x 38 and 24 x 60 inch centrifuges (based on uncorrected sigma values, low speed machines, <3,000 rpm, and data from one experiment) show that the 6 x 12 inch machine was a valid predictor of full scale equipment capacity and performance.
9. The operation and performance of the centrifuges used in this study were excellent.

In the future, municipal sewage plants and industrial waste treatment systems will necessarily undergo considerable expansion and improvement. Many engineers have already discovered the value of applying centrifugal force as a complement to gravity settling operations in order to reduce treatment costs through reduction in space, manpower, and associated

equipment. The outlook for the centrifuge is encouraging, centrifuge manufacturers are meeting the challenge and are designing and building centrifuges specifically for dewatering domestic waste sludges.⁸⁹ (Table 12)

This study was done to search for new knowledge on centrifugation and for independent proof that "accepted" knowledge is valid.

Table 12

Types of Centrifuges and Their Manufacturers in the U.S.

Type of Centrifuge	Manufacturer (distributor) ^a
Batch	
Top-suspended basket	C, E, G, I, J, K, M
Underdriven basket	G, I, K, M
Automatic batch	
Horizontally and vertically mounted axis	B, E, G, I, K, J
Continuous solid bowl	C, E, F, H, I, J, K, L
Continuous screen bowl	
Conical angle basket	A, C, F, I, J
Scroll conveyor	C, F, G, H, I, J, K, L
Oscillating	C, J, L
Single- and multi-stage pusher	B, C, E, G, I, J
Solid bowl-screen combination	A, B, C, F, I, J
Disk	
Nozzle discharge	E, F, I
Valve bowl	D, E, H, I

- ^a *A - Allis Chalmers Mfg. Co., Milwaukee, Wis.
 B - Baker Perkins, Inc., Saginaw, Mich.
 *C - Bird Machine Co., South Walpole, Mass.
 D - Centrico, Inc., Englewood, N. J. (factory in West Germany)
 E - De Laval Separator Co., Poughkeepsie, N. Y.
 *F - Dorr-Oliver, Inc., Stamford, Conn.
 G - Komline Sanderson Engineering Corp., Peapack, N. J.
 H - Pfaudler Co., Div. of Ritter Pfaudler Corp., Rochester, N.Y.
 *I - Sharples Equipment Div. of Pennsalt Chemicals Corp., Warminster, Pa.
 J - Swenson Evaporator Co., Div. of Whiting Corp., Harvey, Ill.
 K - Tolhurst Centrifugals Div. of Ametek, Inc., East Moline, Ill.
 L - Wemco-Conturbex, Process Machinery Div. of Arthur G. McKee and Co., San Francisco, Calif.
 M - Western States Machine Co., Hamilton, Ohio

*These manufacturers advertise centrifuges designed for dewatering sewage sludges.

APPENDICES

APPENDIX 1

TABLES 13 THROUGH 34

TABULATED RESULTS OF ALL EXPERIMENTS

TABLE 13

Effect of Feed Rate, Polymer Dose, and Location of Polymer Addition on Dewatering Anaerobically Digested Sludge at the University of Florida Sewage Treatment Plant

Feed Rate (gpm)	Polymer Dosage (lbs/ton)*	Location Polymer Added	Recovery of Suspended Solids Per cent	Cake Solids Per cent	
1	0	---	63.56 63.84	11.65 11.80	
		In ^a	79.05 79.33	11.25 10.18	
	Out ^b		70.34 69.91	11.29 11.31	
		40	In	99.22 98.89	9.45 9.60
	Out			81.72 82.84	10.83 10.58
		70	In	99.10 99.14	9.63 9.81
	Out			94.85 94.67	10.28 10.35
		2	0	---	54.07 54.30
	In			54.18 55.53	15.52 15.28
			Out	54.09 54.19	15.71 15.92
	40			In	63.95 61.35
			Out		56.76 57.19

Table 13- Continued

Feed Rate (gpm)	Polymer Dosage (lbs/ton)*	Location Polymer Added	Recovery of Suspended Solids Per cent	Cake Solids Per cent
3	70	In	70.51 69.63	12.35 12.41
		Out	68.63 66.89	12.20 12.35
	0	---	48.20 45.68	19.09 20.10
	10	In	47.30 49.81	19.51 18.82
		Out	47.50 48.98	20.01 19.01
	40	In	50.09 52.95	16.05 16.50
		Out	49.88 49.80	16.63 16.70
	70	In	56.77 56.07	14.45 14.44
		Out	56.60 54.83	14.61 15.88

* Polymer dosage in pounds per ton dry solids in feed.

^a Polymer added within centrifuge to liquid pool.

^b Polymer added at discharge side of sludge feed pump.

Centrifuge operation: Bird 6x12 inch continuous solid bowl centrifuge with countercurrent flow operating at a centrifugal force of 1,180 times gravity and a deep pool depth (0.594 inches).

Table 13 - Continued

Feed properties: Anaerobically digested sludge.

Total solids = 4.35% pH = 7.1
 Suspended solids = 4.24% Alkalinity = 1810
 Volatile solids = 64.57% Temperature = 87°F

Polymer addition: CAT-FLOC dosing rate at 10% of the sludge feed rate.

Analysis of Variance of Table 13

Source of Variation	Degrees of Freedom	Recovery Mean Square	Cake Solids Mean Square
Main plots:			
Blocks	1	0.59**	0.011**
Feed rate	(2)	4,113.45**	131.04**
Linear	1	7,649.80**	260.37**
Quadratic	1	577.09**	1.71
Error (a)	2	1.22	0.0033
Sub-plots:			
Polymer dosage	(2)	657.13**	24.33**
Linear	1	1,312.46**	48.31
Quadratic	1	1.80	0.36
FR x PD	4	72.84**	3.93**
Location polymer added	1	192.28**	6.06**
FR x LPA	(2)	69.69**	0.22
Linear	1	126.04**	
Quadratic	1	13.35**	
PD x LPA	(2)	26.95	0.83**
Linear	1	1.23**	0.051**
Quadratic	1	52.67**	1.60**
FR x PD x LPA	4	9.62	0.76
Error (b)	15	0.99	0.12
Total	35		

** Indicates significance at 1% level.

TABLE 14

Effect of Polymer Dosage and Location of Polymer Addition on Recovery, Cake Solids, and Centrate Electrophoretic Mobility When Dewatering Anaerobically Digested Sludge at the University of Florida Sewage Treatment Plant

Polymer Dosage (lbs/ton) ^a	Location of Polymer Addition	Recovery of Suspended Solids Per cent	Cake Solids Per cent	Centrate Electrophoretic Mobility (μ /sec/v/cm)
0	---	63.56	11.65	-1.6
		63.84	11.80	-3.0
10	In ^b	79.05	10.25	-1.9
		79.33	10.18	-2.5
	Before ^c	69.18	11.40	-1.0
		70.35	11.28	-1.2
	After ^d	70.34	11.29	-1.8
		69.91	11.31	-1.3
40	In	99.22	9.45	-0.1
		98.89	9.60	-1.3
	Before	80.74	10.92	-1.4
		80.15	10.88	-1.6
	After	81.72	10.83	-1.8
		82.84	10.58	-1.9
70	In	99.10	9.63	+2.0
		99.14	9.81	+2.4
	Before	94.59	10.39	-0.7
		92.66	10.56	-0.2
	After	94.85	10.28	-1.6
		94.67	10.35	-3.1

^aPolymer dosage in pounds per ton dry solids in feed.

^bPolymer added within centrifuge liquid pool.

^cPolymer added at suction side of sludge feed pump.

Table 14 - Continued

^d Polymer added at discharge side of sludge feed pump.

Centrifuge operation: Bird 6x12 inch continuous solid bowl centrifuge with countercurrent flow operating at a centrifugal force of 1,180 times gravity, a deep pool depth (0.594 inches) and a sludge feed rate of 1 gpm.

Feed properties: Anaerobically digested sludge.

Total solids = 4.35%	pH = 7.1	Alkalinity = 1810
Suspended solids = 4.24%	Temperature = 87°F	
Volatle solids - 64.57%	Electrophoretic mobility =	
	1.5 /sec/v/cm	

Polymer addition: CAT-FLOC added at 0.10 gpm.

Analysis of Variance of Table 14

Source of Variation	Degrees of Freedom	Recovery Mean Square	Cake Solids Mean Square	Electrophoretic Mobility Mean Square
Blocks	1	0.0012	0.00067	0.32
Polymer dosage	(2)	798.28**	0.98**	3.40**
Linear	1	1,560.66**	1.83**	6.02**
Quadratic	1	35.90**	0.14**	0.78
Location polymer added	2	223.45**	2.10**	4.26**
PD x LPA	4	27.07	0.067	3.75**
Error	8	0.43	0.011	0.26
Total	17			

* Indicates significance at 5% level.

** Indicates significance at 1% level.

TABLE 15

Effect of Centrifugal Force, Polymer Dosage, and Location of Polymer Addition on Recovery, Cake Solids, and Centrate Electrophoretic Mobility When Dewatering Anaerobically Digested Sludge at the University of Florida Sewage Treatment Plant

Centrifugal Force (Times gravity)	Polymer Dosage (lbs/ton)*	Location Polymer Added	Recovery of Suspended Solids Per cent	Cake Solids Per cent	Electrophoretic Mobility (μ /sec/v/cm)
680	0	---	61.14	11.46	-4.1
			62.43	11.88	-3.8
	40	In ^a	94.02	8.46	-3.6
			94.08	8.30	-2.1
			Before ^b	10.40	-2.4
			77.22	9.88	-2.8
After ^c	79.26	9.65	-2.4		
	74.28	9.90	-2.6		
1180	0	---	63.56	11.65	-1.6
			63.84	11.80	-3.0
	40	In	99.22	9.45	-0.1
			98.89	9.60	-1.3
			Before	10.92	-1.4
			80.74	10.88	-1.6
After	81.72	10.83	-1.8		
	82.84	10.58	-1.9		
2880	0	---	70.82	13.25	-4.6
			71.57	13.38	-4.0
	40	In	99.06	10.51	-3.4
			99.13	10.50	-2.9
			Before	10.73	-3.9
			90.79	11.00	-4.1
91.57					

Table 15 - Continued

Centrifugal Force (Times gravity)	Polymer Dosage (lbs/ton) *	Location Polymer Added	Recovery of Suspended Solids Per cent	Cake Solids Per cent	Electrophoretic Mobility (μ /sec/v/cm)
		After	91.26	11.08	-4.2
			91.65	11.00	-4.0

* Polymer dosage in pounds per ton dry solids in feed.

^a Polymer added within centrifuge to liquid pool.

^b Polymer added at suction side of sludge feed pump.

^c Polymer added at discharge side of sludge feed pump.

Analysis of Variance of Table 15

Source of Variation	Degrees of Freedom	Recovery Mean Square	Cake Solids Mean Square	Electrophoretic Mobility Mean Square
Main plots:				
Blocks	1	1.00	0.0085	0.00056
Centrifugal force	(2)	200.28*	2.96**	4.47
Linear	1	379.20**	4.45**	2.05
Quadratic	1	21.35	7.46*	6.89*
Error (a)	2	3.48	0.016	0.28
Sub-plots:				
Polymer dosage	(2)	406.20**	2.45**	1.69*
Linear	1			
Quadratic	1			
CF x PD	4	21.04**	0.27*	1.66*
Error (b)	6	1.19	0.037	0.27
Total	17			

* Indicates significance at 5% level.

** Indicates significance at 1% level.

Table 16

Effect of Three Cationic Polymers on Dewatering Anaerobically Digested Sludge When Dosages of Equal Cost Used to Dewater Anaerobically Digested Sludge at the University of Florida Sewage Treatment Plant

Cationic Polymer	Polymer Dosage (\$/ton)	Location Polymer Added	Recovery of Suspended Solids Per cent	Cake Solids Percent	
CAT-FLOC (Calgon)	3	In*	79.05 79.33	10.25 10.18	
		Out**	70.34 69.91	11.29 11.31	
	12	In	99.22 98.89	9.45 9.60	
		Out	81.72 82.84	10.83 10.58	
	Purifloc C-31 (Dow)	3	In	78.76 80.52	10.35 10.40
			Out	70.86 70.67	11.37 11.36
12		In	99.31 99.28	9.78 9.90	
		Out	84.89 84.35	10.61 10.43	
Primafloc C-7 (Rohm & Haas)	3	In	88.38 86.57	9.77 9.65	
		Out	70.48 69.90	11.24 11.16	
	12	In	98.84 98.91	9.91 9.99	
		Out	97.73 97.72	9.60 9.72	

Table 16 - Continued

Cationic Polymer	Polymer Dosage (\$/ton)	Location Polymer Added	Recovery of Suspended Solids Per cent	Cake Solids Percent
None	0	--	63.56	11.65
		--	63.84	11.80

* Polymer added within centrifuge to liquid pool.

** Polymer added at discharge side of sludge feed pump.

Centrifuge operation: Bird 6x12 inch continuous solid bowl centrifuge with countercurrent flow operating at a deep pool depth (0.594 inches) and a sludge feed rate of 1 gpm. Centrifugal force of 1180 times gravity.

Feed properties: Anaerobically digested sludge

Total solids = 4.35% pH = 7.1 Alkalinity = 1810
 Suspended solids = 4.24% Temperature = 87°F
 Volatile solids = 64.57% Electrophoretic mobility =
 1.5μ/sec/v/cm

Polymer addition: Polymer added at 0.10 gpm.

Analysis of Variance of Table 16

Source of Variation	Degrees of Freedom	Recovery Mean Square	Cake Solids Mean Square
Blocks	1	0.021	0.00070
Polymer	2	80.67**	0.15**
Polymer dosage	1	1,818.47**	3.35**
P x PD	2	6.60**	0.041**
Location polymer added	1	766.93**	5.33**
P x LPA	2	7.17**	0.054*
PD x LPA	2	87.71**	0.82**
Error	11	0.39	0.0080
Total	23		

* Indicates significance at 5% level.

** Indicates significance at 1% level.

Table 17

Effect of Centrifugal Force, Polymer Dosage, and Location of Polymer Addition on Recovery, Cake Solids, and Centrate Electrophoretic Mobility and Streaming Current When Dewatering Anaerobically Digested Sludge at the University of Florida Sewage Treatment Plant

Centri- fugal Force (Times gravity)	Polymer Dosage (lbs/ton)*	Location Polymer Added	Recovery of Suspended Solids Per cent	Cake Solids Per cent	Centrate Electro- phoretic Mobility (μ /sec/v/cm)	Centrate SCD Instrument Reading (μ amps)
680	0	--	65.70	10.99	-3.5	-4.4
			62.68	11.61	-3.1	-4.2
	20	In ^a	71.47	9.50	-2.5	-3.0
			72.33	9.41	-2.2	-3.4
		Out ^b	66.03	10.68	-1.2	-4.2
			67.41	10.62	-1.5	-4.6
	40	In	96.95	8.07	-0.1	-0.8
			97.15	8.01	0.0	-0.5
	60	In	99.22	8.30	+2.3	+3.5
			99.26	8.33	+1.9	+2.9
		Out	83.68	10.06	-1.7	-2.0
			83.43	10.10	-1.7	-2.2
2880	0	--	75.48	13.91	-4.0	-6.3
			76.20	13.66	-3.6	-6.0
	20	In	88.83	10.75	-1.7	-5.9
			89.06	10.71	-1.4	-5.0
		Out	78.99	11.93	-0.9	-5.1
			78.73	11.54	-1.1	-4.9
	40	In	99.05	10.30	0.0	-3.7
			98.86	10.38	-0.2	-3.4
		Out	87.08	11.18	-1.4	-4.6
			85.94	11.24	-1.8	-4.0

Table 17 - Continued

Centrifugal Force (Times gravity)	Polymer Dosage (lbs/ton)*	Location Polymer Added	Recovery of Suspended Solids Per cent	Cake Solids Per cent	Centrate Electrophoretic Mobility (μ /sec/v/cm)	Centrate SCD** Instrument Reading (μ amps)
60		In	99.45	10.30	+2.4	+3.4
			99.63	10.24	+2.0	+3.5
		Out	96.37	11.00	-0.7	-3.7
			97.22	10.91	-0.0	-3.0

* Polymer dosage in pounds per ton dry solids in feed.

** Streaming Current Detector.

^a Polymer added within centrifuge to liquid pool.

^b Polymer added at suction side of sludge feed pump.

Centrifuge operation: Bird 6x12 continuous solid bowl centrifuge with countercurrent flow operating at a deep pool depth (0.594 inches) and a sludge feed rate of 1 gpm.

Feed properties: Anaerobically digested sludge.

Total solids = 3.78%	pH = 7.0	Alkalinity = 1760
Suspended solids = 3.45%	Temperature = 77°F	
Volatile solids = 65.50%	Electrophoretic Mobility = 1.8 μ /sec/v/cm	

Polymer addition: CAT-FLOC added at 0.10 gpm.

Table 17 - Continued

Analysis of Variance of Table 17

Source of Variation	Degrees of Freedom	Recovery Mean Square	Mobility Mean Square	SCD ^b Mean Square
Main plots:				
Blocks	1	1.13	0.12	0.034
Centrifugal force	1	533.36*	0.84	10.53
Error (a)	1	1.43	0.010	0.92
Sub-plots:				
Polymer dosage		694.87**	8.37**	48.00**
Linear	1	1,321.50**	16.20**	92.64**
Quadratic	1	68.23**	0.54**	3.36**
CF x PD		54.42**	0.16*	1.22**
Linear	1	61.19**	0.0056	0.86**
Quadratic	1	18.84**	0.32*	1.58**
Location polymer added	1	784.78**	11.90**	42.93**
CF x LPA	1	54.42**	0.050	0.57**
PD x LPA	2	55.72**	8.77**	17.84**
CF x PD x LPA	2	45.84**	0.20*	1.68**
Error (b)	10	0.54	0.035	0.053
Total	23			

*Indicates significance at 5% level.

**Indicates significance at 1% level.

Table 18

Effect of Centrifugal Force, Pool Depth, and Sludge Feed Rate on Dewatering Anaerobically Digested Sludge at the University of Florida Sewage Treatment Plant

Centrifugal Force (Times gravity)	Pool Depth (Inches)	Feed Rate (gpm)	Recovery of Suspended Solids Per cent	Cake Solids Per cent
680	0.250	1	51.51	16.73
			51.37	15.73
		2	42.74	19.95
	44.20		16.86	
	3	42.90	24.80	
		42.24	26.71	
	0.422	1	58.20	10.99
			59.97	11.32
		2	61.94	12.63
54.13			12.66	
3		44.79	16.15	
		46.35	17.91	
0.594	1	98.76	8.89	
		99.08	8.97	
	2	61.62	11.08	
		65.71	10.57	
	3	54.84	11.36	
		53.39	11.84	
1180	0.250	1	52.71	18.27
			53.51	16.69
		2	50.11	19.29
	50.85		16.23	
	3	47.46	23.43	
		44.37	25.69	

Table 18- Continued

Centrifugal Force (Times gravity)	Pool Depth (Inches)	Feed Rate (gpm)	Recovery of Suspended Solids Per cent	Cake Solids Per cent
2880	0.422	1	58.84	13.57
			61.32	13.12
		2	58.76	12.80
	59.60		13.58	
	3	51.47	16.91	
		46.86	17.70	
	0.594	1	99.30	9.60
			99.52	9.30
			2	72.30
74.61	11.63			
3	1	60.76	13.57	
		57.13	13.97	
		2	50.00	22.14
54.37	18.05			
3	2	49.86	20.88	
		51.41	18.90	
		3	55.32	17.32
55.49	16.63			
3	0.594	1	99.96	11.07
			99.84	11.12
		2	75.58	11.88
74.72	13.25			
3	3	64.43	13.97	
		65.56	15.22	

Centrifuge operation: Bird 6x12 inch continuous solid bowl centrifuge with counter current flow.

Table 18 - Continued

Feed properties: Anaerobically digested sludge.

Total solids = 2.80% pH = 6.8
 Suspended solids = 2.51% Alkalinity = 1530
 Volatile solids = 68.42% Temperature = 77° F

Polymer addition: CAT-FLOC dosage of 40 pounds per ton dry solids in feed added within centrifuge liquid pool at 10% of the sludge feed rate.

Analysis of Variance of Table 18

Source of Variation	Degrees of Freedom	Recovery Mean Square	Cake Solids Mean Square
Main plots:			
Blocks	1	1.22*	1.40
Centrifugal force	(2)	182.71*	8.38
Linear	1	311.01	15.61
Quadratic	1	54.40	1.15
Error (a)	2	4.78	1.07
Sub-plots:			
Pool depth	(2)	3,638.03**	320.46**
Linear	1	6,866.33**	626.92**
Quadratic	1	409.73**	14.00
CF x PD	(4)	6.36	3.53
CF _L x PD _L	1	10.07	10.15
CF _L x PD _Q	1	0.40	2.95
CF _L x PD _L	1	0.34*	0.83
CF _Q x PD _L	1	14.64*	0.18
Error ^Q (b)	6	1.70	2.37
Sub-sub-plots:			
Feed rate	(2)	1,676.35**	88.82**
Linear	1	3,300.12**	166.79**
Quadratic	1	52.58	10.84**
CF x FR	(4)	23.70**	9.69**
CF _L x FR _L	1	65.79**	30.16**
CF _L x FR _Q	1	0.13	6.11*
CF _L x FR _L	1	2.95	81.79**
CF _Q x FR _L	1	25.94*	2.48

Analysis of Variance of Table 18 - Continued

Source of Variation	Degrees of Freedom	Recovery Mean Square	Cake Solids Mean Square
PD x FR	(4)	576.22**	2.94*
PD _L x FR _L	1	1,736.89	4.51*
PD _L x FR _Q	1	115.19**	7.16*
PD _Q x FR _L	1	273.12**	6.85*
PD _Q x FR _Q	1	179.69**	2.08
CF x PD x FR	6	8.09	5.28**
Error (c)	<u>18</u>	4.28	0.96
Total	53		

*Indicates significance at 5% level.

**Indicates significance at 1% level.

Table 19

Effect of Sludge Concentration, Centrifugal Force, Polymer Dosage, and Deep Pool Depth on Dewatering Anaerobically Digested Sludge at the University of Florida Sewage Treatment Plant

Centrifugal Force (Times gravity)	Sludge Concentration Per cent	Polymer Dosage (lbs/ton)*	Recovery of Suspended Solids Per cent	Cake Solids Per cent	
680	1.5	0	67.82	09.71	
			69.48	10.27	
		20	98.43	08.64	
			96.20	08.46	
	40	99.86	08.54		
		98.98	08.47		
	60	99.08	08.80		
		99.41	08.95		
	2.5	0	79.55	09.90	
			80.25	09.89	
			20	99.38	08.78
				99.34	08.46
40		99.73	08.72		
		99.74	09.09		
60		99.66	09.13		
		99.98	09.01		
3.5	0	73.70	11.74		
		72.96	12.12		
		20	86.59	09.80	
			86.01	10.03	
	40	96.99	09.00		
		97.92	08.79		
	60	99.94	09.38		
		99.99	09.44		

Table 19 - Continued

Centrifugal Force (Times gravity)	Sludge Concentration Per cent	Polymer Dosage (lbs/ton)*	Recovery of Suspended Solids Per cent	Cake Solids Per cent
2880	1.5	0	90.69	11.00
			89.45	11.21
		20	99.95	10.29
			99.52	10.62
	40	99.42	10.28	
		99.54	10.21	
	60	99.59	10.38	
		99.95	09.75	
	2.5	0	89.04	11.64
			87.41	11.42
		20	99.27	10.44
			98.92	10.96
40		99.97	11.07	
		99.90	11.12	
60		99.61	10.80	
		99.51	09.05	
3.5	0	81.45	13.70	
		81.25	13.61	
	20	90.64	11.73	
		91.45	11.96	
	40	98.85	11.45	
		99.34	11.28	
	60	99.99	12.21	
		99.99	12.38	

* Polymer dosage in pounds per ton dry solids in feed.

Table 19- Continued

Centrifuge operation: Bird 6x12 inch continuous solid bowl centrifuge with countercurrent flow operating at a deep pool depth (0.594 inches) and a sludge feed rate of 1 gpm.

Feed properties: Anaerobically digested sludge diluted with supernatant to obtain concentrations.

Polymer addition: Purifloc C-31 added within centrifuge liquid pool at 0.10 gpm.

Analysis of Variance of Table 19

Source of Variation	Degrees of Freedom	Recovery Mean Square	Cake Solids Mean Square
Main plots:			
Blocks	1	0.15*	0.70*
Centrifugal force	1	182.95	39.31
Error (a)	1	0.065	0.11
Sub-plots:			
Sludge concentration	(2)	89.66**	9.50**
Linear	1	79.10**	16.59**
Quadratic	1	100.23**	2.42**
CF x SC	(2)	17.13**	0.63**
CF x SC _L	1	12.49**	1.17**
CF x SC _L ^Q	1	21.76**	0.086
Error (b)	4	0.25	0.048
Sub-sub-plots:			
Polymer dosage	(3)	1,001.36**	6.12**
Linear	1	2,315.65**	11.68**
Quadratic	1	646.73**	6.24**
Cubic	1	41.69**	0.46
CF x PD	3	103.18**	0.26
SC x PD	6	33.37**	0.73**
LF x SC x PD	6	16.20**	0.27
Error (c)	18	0.39	0.12
Total	47		

* Indicates significance at 5% level.

** Indicates significance at 1% level.

Table 20

Effect of Sludge Concentration, Centrifugal Force, Polymer Dosage, and Shallow Pool Depth on Dewatering Anaerobically Digested Sludge at the University of Florida Sewage Treatment Plant

Centrifugal Force (Times gravity)	Sludge Concentration Per cent	Polymer Dosage (lbs/ton)*	Recovery of Suspended Solids Per cent	Cake Solids Per cent
680	1.5	0	50.99	24.24
			48.76	24.43
		20	50.24	25.39
			49.52	25.85
	40	58.65	24.41	
		59.56	25.18	
	60	59.04	23.51	
		62.28	23.68	
	2.5	0	58.84	23.33
			58.51	22.36
		20	61.38	24.54
			60.65	24.40
40	60.78	23.44		
	59.57	23.20		
60	63.68	21.65		
	64.85	22.02		
3.5	0	54.28	22.21	
		53.71	23.77	
	20	55.52	26.74	
		54.38	26.50	
40	55.80	26.55		
	54.51	25.85		
60	60.51	24.92		
	59.22	24.43		

Table 20 - Continued

Centrifugal Force (Times gravity)	Sludge Concentration Per cent	Polymer Dosage (lbs/ton)*	Recovery of Suspended Solids Per cent	Cake Solids Per cent
2880	1.5	0	74.09 76.07	22.60 22.74
		20	72.71 69.43	23.75 22.90
		40	64.26 63.51	22.77 23.73
		60	74.76 72.18	22.53 21.47
	2.5	0	63.06 63.03	23.67 23.40
		20	62.61 64.46	24.76 25.51
		40	67.09 66.64	22.17 22.73
		60	69.61 70.93	22.71 22.58
	3.5	0	62.48 61.89	26.78 26.93
		20	61.29 61.81	27.64 28.16
		40	64.84 62.23	25.83 26.94
		60	62.84 63.69	26.07 26.03

* Polymer dosage in pounds per ton dry solids in feed.

Table 20- Continued

Centrifuge operation: Bird 6x12 inch continuous solid bowl centrifuge with countercurrent flow operating at a shallow pool depth (0.250 inches) and a sludge feed rate of 3 gpm.

Feed properties: Anaerobically digested sludge diluted with supernatant to obtain concentrations.

Polymer addition: Purifloc C-31 added within centrifuge liquid pool at 0.30 gpm.

Analysis of Variance of Table 20

Source of Variation	Degrees of Freedom	Recovery Mean Square	Cake Solids Mean Square
Main plots:			
Blocks	1	0.13	0.14
Centrifugal Force	1	1,010.90**	0.068
Error (a)	1	0.0037	0.025
Sub-plots:			
Sludge concentration	(2)	81.20**	33.25**
Linear	1	101.71**	40.88**
Quadratic	1	60.69**	25.62**
CF x SC	(2)	142.50**	12.10**
Linear	1	174.99**	23.82**
Quadratic	1	110.02**	0.37
Error (b)	4	1.33	
Sub-sub-plots:			
Polymer dosage	(3)	64.94**	9.42**
Linear	1	145.83**	3.24
Quadratic	1	47.72**	19.87**
Cubic	1	1.28	5.15**
CF x PD	3	22.19**	1.51**
SC x PD	6	4.69*	0.86*
CF x SC x PD	6	34.58**	0.84*
Error (c)	18	1.32	0.24
Total	47		

* Indicates significance at 5% level.

** Indicates significance at 1% level.

Table 21

Effect of Pool Depth, Polymer Dosage, and Location of Polymer Addition on Dewatering Anaerobically Digested Sludge at the Water Pollution Control Plant, Treasure Island, Florida

Feed Rate (gpm)	Pool Depth (inches)	Polymer Dosage (lbs/ton)*	Location Polymer Added	Recovery of Suspended Solids Per cent	Cake Solids Per cent
1	0.594	0	---	60.56 61.00	12.57 12.45
			In ^a	99.05 98.68	8.51 8.68
		10	Out ^b	86.83 84.26	9.30 9.32
			In	99.90 99.91	12.63 11.89
		30	Out	99.90 98.51	12.63 12.80
			In	99.90 98.51	12.63 12.80
	0.422	0	---	48.43 50.12	17.43 17.18
			In	80.04 79.69	10.38 10.21
		10	Out	69.32 70.11	11.88 11.77
			In	98.86 99.69	9.91 10.82
		30	Out	98.95 99.85	12.67 11.37
			In	98.95 99.85	12.67 11.37
2	0.594	0	---	55.57 53.98	15.78 15.90
			In	56.11 55.78	15.00 14.97
		10	In	56.11 55.78	15.00 14.97

Table 21 - Continued

Feed Rate (gpm)	Pool Depth (inches)	Polymer Dosage (lbs/ton) *	Location Polymer Added	Recovery of Suspended Solids Per cent	Cake Solids Per cent	
3	0.594	0	Out	56.03	15.33	
				55.87	15.50	
			30	In	60.72	14.68
					60.55	14.70
			Out	58.22	14.79	
				57.86	14.84	
			---	---	47.82	19.87
					46.13	21.06
			In	51.66	16.73	
				53.01	16.12	
			Out	48.91	16.66	
				49.82	16.24	
30	In	57.67	14.30			
		55.55	14.69			
Out	50.25	16.87				
	51.28	16.19				

* Polymer dosage in pounds per ton dry solids in feed.

^a Polymer added within centrifuge to liquid pool.

^b Polymer added at discharge side of sludge feed pump.

Centrifuge operation: Bird 6x12 inch continuous solid bowl centrifuge with countercurrent flow operating at a centrifugal force of 1,180 times gravity, at medium and deep pool depths, and feed rate of 1 gpm.

Feed properties: Anaerobically digested sludge.

Total solids = 3.79%	pH = 7.1	Alkalinity = 1920
Suspended solids = 3.48%	Temperature = 80° F	
Volatile solids = 53.83%	Electrophoretic mobility =	
	μ/sec/v/cm	

Table 21 - Continued

Polymer addition: Primafloc C-7 added at 10% of the sludge feed rate.

Table 22

Effect of Feed Rate, Polymer Dose, and Location of Polymer Addition on Dewatering Anaerobically Digested Sludge at the Water Pollution Control Plant, Treasure Island, Florida

Feed Rate (gpm)	Polymer Dosage (lbs/ton)*	Location Polymer Added	Recovery of Suspended Solids Per cent	Cake Solids Per cent
10	0	--	64.10	14.63
			60.89	14.72
	12.5	In ^a	84.73	10.46
			82.56	10.53
		Out ^b	75.12	12.03
			72.04	12.32
	25.0	In	99.05	11.25
			99.48	11.13
		Out	74.46	11.62
			77.60	11.83
	50.0	In	99.25	12.10
			99.76	13.65
Out		99.48	14.23	
		99.59	15.18	
15	0	--	51.30	16.24
			55.52	15.67
	12.5	In	76.95	11.10
			80.94	10.61
		Out	60.76	13.15
			64.72	12.98
	25.0	In	99.40	12.05
			97.31	10.10
	Out	73.09	13.72	
		75.11	13.27	

Table 22 - Continued

Feed Rate (gpm)	Polymer Dosage (lbs/ton)*	Location Polymer Added	Recovery of Suspended Solids Per cent	Cake Solids Per cent
20	50.0	In	99.11 98.28	12.02 12.41
		Out	99.47 99.78	12.43 16.25
	0	--	40.71 44.76	19.03 18.12
	12.5	In	70.22 74.00	12.45 11.36
		Out	68.48 66.32	13.41 13.68
	25.0	In	99.18 98.87	12.58 13.00
Out		69.49 65.38	14.03 14.75	
50.0	In	99.57 99.46	12.13 12.49	
	Out	99.41 99.08	14.98 15.16	

* Polymer dosage in pounds per ton dry solids in feed.

^a Polymer added within centrifuge to liquid pool.

^b Polymer added at discharge side of sludge feed pump.

Centrifuge operation: Bird 24x38 inch continuous solid bowl centrifuge with countercurrent flow operating at a centrifugal force of 1,335 times gravity and a maximum pool depth (2.50 inches).

Feed properties: Anaerobically digested sludge.

Table 22 - Continued

Total solids = 3.89%	pH = 7.0	Alkalinity = 1700
Suspended solids = 3.61%	Temperature = 85° F	
Volatile solids = 50.90%	Electrophoretic mobility =	1.9 μ/sec/v/cm

Polymer addition: Primafloc C-7 added at 10% of the sludge feed rate.

Analysis of Variance of Table 22

Source of Variation	Degrees of Freedom	Recovery Mean Square	Cake Solids Mean Square
Main plots:			
Blocks	1	0.46	0.00
Feed rate	2	62.97*	4.01
Error (a)	2	3.17	1.01
Sub-plots:			
Polymer dosage	(2)	2,086.82**	13.20**
Linear	1	4,171.21**	23.90**
Quadratic	1	2.43	2.51**
FR x PD	(4)	25.37**	1.70**
FR _L x PD _L	1	75.99**	2.22**
FR _L x PD _Q	1	0.0088	2.96**
FR _Q x PD _L	1	14.53**	0.98
FR _Q x PD _Q	1	10.93**	0.64
Location polymer added	1	1,341.27**	41.37**
FR x LPA	(2)	3.81	2.31**
FR _L x LPA	1	1.82	0.63
FR _L x LPA	1	5.80	3.99**
PD x LPA	(2)	531.61**	2.02**
PD _L x LPA	1	161.93**	2.26**
PD _Q x LPA	1	901.28**	1.77*
FR x PD x LPA	4	25.09**	0.36
Error (b)	15	2.91	0.25
Total	35		

* Indicates significance at 5% level.

** Indicates significance at 1% level.

Table 23

Effect of Feed Rate, Polymer Dosage, and Location of Polymer Addition on Dewatering Return Activated Sludge at the University of Florida Sewage Treatment Plant

Feed Rate (gpm)	Polymer Dosage (lbs/ton)*	Location of Polymer Addition	Recovery of Suspended Solids Per cent	Cake Solids Per cent	Centrate Electro-phoretic Mobility (μ /sec/v/cm)	Centrate SCD** Instrument Reading (μ amps)
1	0	---	0	0	-1.7	-4.5
			0	0	-2.0	-4.7
	10	In ^a	53.24	2.76	-1.8	-3.9
			56.79	2.81	-1.9	-4.1
		Out ^b	0	0	-1.8	-3.8
			0	0	-1.6	-4.1
	30	In	83.22	3.19	-1.1	-1.0
			86.41	3.34	-0.9	-1.0
		Out	40.69	2.95	-1.4	-3.9
			45.63	2.99	-1.6	-3.8
	50	In	99.08	3.83	+0.9	+2.1
			98.90	3.92	0	+1.8
Out		84.09	3.32	-2.0	-3.2	
		88.90	3.55	-1.7	-3.4	
2	0	---	0	0	-2.2	-4.9
			0	0	-2.0	-4.8
	10	In	23.90	2.45	-1.3	-4.1
			18.25	2.88	-1.4	-4.1
		Out	9.18	2.53	-1.6	-4.4
			16.01	2.60	-1.6	-4.3
	30	In	72.21	2.53	-1.8	-3.2
			74.20	2.59	-1.6	-3.1
		Out	40.28	2.87	-1.7	-4.2
			38.24	2.68	-2.0	-4.3

Table 23 - Continued

Feed Rate (gpm)	Polymer Dosage (lbs/ton) *	Location of Polymer Addition	Recovery of Suspended Solids Per cent	Cake Solids Per cent	Centrate Electro-phoretic Mobility (μ /sec/v/cm)	Centrate SCD** Instrument Reading (μ amps)
50		In	96.00	2.67	-1.1	+1.0
			95.98	2.74	-1.2	-0.8
		Out	73.37	3.34	-1.7	-3.5
			79.48	3.63	-1.5	-3.5

* Polymer dosage in pounds per ton dry solids in feed.

** Streaming current detector

^a Polymer added within centrifuge liquid pool.

^b Polymer added to suction side of sludge feed pump.

Centrifuge operation: Bird 6x12 inch continuous solid bowl centrifuge with countercurrent flow operating at a centrifugal force of 1,180 times gravity and deep pool depth (0.594 inches).

Feed properties: Return activated sludge.

Total solids = 0.53%	SVI = 210	pH = 7.1
Suspended solids = 0.44%	Electrophoretic mobility =	
Volatile solids = 81.07%	1.8 μ /sec/v/cm	
	SCD instrument reading = -3.0 μ amps	

Polymer addition: CAT-FLOC added at 10% of the sludge feed rate.

Analysis of Variance of Table 23

Source of Variation	Degrees of Freedom	Recovery Mean Square	Cake Solids Mean Square	Mobility ^a Mean Square	SCD ^b Mean Square
Main plots:					
Blocks	1	23.07	0.069	0.094	0.28
Feed rate	1	415.42	0.030	0.63	4.34
Error (a)	1	3.44	0.0012	0.070	0.027
Sub-plots:					
Polymer dose	(2)	9,108.60**	3.87**	0.56**	17.43**
Linear	1	18,119.18**	7.52**	0.90**	33.93**
Quadratic	1	98.01**	0.22**	0.21	0.94*
FR x PD	(2)	9.04	2.00**	0.34*	0.57
Linear	1	17.12	3.18**	0.56**	0.60
Quadratic	1	0.96	0.81**	0.12	0.54
Location polymer added	1	4,882.34**	1.15**	1.87**	28.17**
FR x LPA	1	370.91**	3.25**	0.45*	1.60**
PD x LPA	2	505.07**	1.54**	1.28**	9.41**
FR x PD x LPA	2	766.55**	0.62**	0.93**	0.67*
Error (b)	<u>10</u>	7.07	0.013	0.46	0.15
Total	22				

^aElectrophoretic mobility of particles in centrate.

^bStreaming current detector instrument reading.

*Indicates significance at 5% level.

**Indicates significance at 1% level.

Table 24

Effect of Centrifugal Force, Feed Rate, and Polymer Dosage on Recovery, Cake Solids, and Centrate Electrophoretic Mobility and Streaming Current When Dewatering Return Activated Sludge at the University of Florida Sewage Treatment Plant

Centrifugal Force (Times gravity)	Feed Rate (gpm)	Polymer Dosage (lbs/ton)*	Recovery of Suspended Solids Per cent	Cake Solids Per cent	Centrate Electrophoretic Mobility (μ /sec/v/cm)	Centrate SCD** Instrument Reading (μ amps)
680	1	0	0	0	-3.8	-5.8
			0	0	-2.9	-4.6
	10	30	37.99	2.16	-2.4	-3.1
			44.02	2.27	-2.1	-3.0
		70	64.49	2.89	-1.8	-2.6
			70.28	2.80	-1.5	-2.7
		90	82.77	3.21	-1.5	-2.6
			83.58	3.33	-1.3	-2.3
	2	0	99.64	3.57	+2.0	+3.3
			99.30	4.44	+2.2	+3.8
		10	99.74	3.76	+2.0	+2.5
			99.30	4.44	+2.2	+3.8
		30	0	0	-3.6	-5.4
			0	0	-3.0	-5.1
50	0	0	-2.6	-3.8		
	0	0	-2.3	-3.7		
70	30	63.67	1.83	-1.2	-1.4	
		54.94	1.80	-1.8	-2.0	
	70	74.41	1.86	-0.4	-0.1	
		72.70	1.78	0.0	-0.7	
	90	87.33	2.10	+0.8	+2.4	
		86.35	2.19	+1.8	+3.8	
90	94.03	2.49	+1.5	+2.6		
	94.66	2.51	+2.1	+3.7		

Table 24 Continued

Centrifugal Force (Times gravity)	Feed Rate (gpm)	Polymer Dosage (lbs/ton)*	Recovery of Suspended Solids Per cent	Cake Solids Per cent	Centrate Electro-phoretic Mobility (μ /sec/v/cm)	Centrate SCD** Instrument Reading (μ amps)
2880	1	0	0	0	-3.5	-5.7
			0	0	-4.6	-6.0
	10	0	0	0	-3.0	-4.2
			0	0	-2.6	-3.5
		30	20.41	3.66	-2.0	-2.6
			16.98	3.21	-2.5	-3.1
		50	36.61	4.62	-1.5	-1.7
			37.19	3.88	-1.5	-1.6
	70	98.39	5.88	0.0	+2.0	
		96.76	5.73	-0.2	+1.8	
	90	97.72	6.21	+2.0	+2.2	
		98.49	6.31	+2.2	+2.3	
	2	0	0	0	-4.0	-5.6
			0	0	-3.9	-5.4
10		0	0	-3.6	-4.6	
		0	0	-3.0	-4.0	
30		0	0	-3.1	-4.0	
		0	0	-2.7	-3.5	
50		39.68	4.62	-1.9	-2.2	
		35.50	4.18	-2.3	-2.7	
70	70.14	5.41	0.0	1.7		
	64.33	5.37	-0.5	-2.0		
90	98.37	5.96	+2.0	+2.8		
	98.47	5.99	+1.6	+2.3		

* Polymer dosage in pounds per ton dry solids in feed.

** Streaming Current Detector.

Table 24 - Continued

Centrifuge operation: Bird 6x12 inch continuous solid bowl centrifuge with countercurrent flow operating at a deep pool depth (0.594 inches).

Feed properties: Return activated sludge.

Total solids = 0.57%

SVI = 200

Suspended solids = 0.50%

Electrophoretic mobility =

Volatile solids = 80.94%

2.5 μ /sec/v/cm

SCD instrument reading = -5.0

Polymer addition: CAT-FLOC added within centrifuge liquid pool at 10% of the sludge feed rate.

Table 25

Effect of Centrifugal Force, Feed Rate, and Polymer Dosage on Dewatering Return Sludge from Extended Aeration Unit at the University of Florida

Centrifugal Force (Times gravity)	Feed Rate (gpm)	Polymer Dosage (lbs/ton)*	Recovery of Suspended Solids Per cent	Cake Solids Per cent	
680	1	0	90.09	5.02	
			87.61	5.23	
		10	95.28 93.89	4.92 4.98	
	2	0	30	96.95 96.80	5.03 5.00
				0	85.22 85.20
			10	94.63 93.00	4.88 4.92
		30	0	95.68 90.39	4.70 4.84
				0	85.75 87.22
			10	96.81 97.42	6.22 6.10
	1180	1	0	98.10 98.74	6.02 5.98
				0	84.77 85.78
			10	94.43 95.05	5.58 5.73
2		0	97.71 97.03	5.00 5.12	
			0		
		30			

Table 25 - Continued

Centrifugal Force (Times gravity)	Feed Rate (gpm)	Polymer Dosage (lbs/ton)*	Recovery of Suspended Solids Per cent	Cake Solids Per cent
2880	1	0	77.00	7.04
			74.33	7.29
		10	91.63	6.81
			90.65	6.84
		30	97.02	6.69
			94.90	6.65
	2	0	68.91	7.34
			67.70	7.51
		10	93.13	6.83
			83.62	6.71
		30	96.30	6.30
			96.35	6.43

* Polymer dosage in pounds per ton dry solids in feed.

Centrifuge operation: Bird 6x12 inch continuous solid bowl centrifuge with countercurrent flow operating at a deep pool depth (0.594 inches).

Feed properties: Extended aeration return sludge.

Total solids =	0.84%	SVI = 115
Suspended solids =	0.72%	Temperature = 80°F
Volatiline solids =	81.10%	pH = 7.1

Polymer addition: CAT-FLOC added within centrifuge liquid pool at 10% of the sludge feed rate.

Analysis of Variance of Table 25

Source of Variation	Degrees of Freedom	Recovery Mean Square	Cake Solids Mean Square
Main plots:			
Blocks	1	15.64	0.029
Centrifugal force	(2)	182.95*	10.75**
Linear	1	318.24**	19.87**
Quadratic	1	47.66**	1.64
Error (a)	2		0.0039
Sub-plots:			
Feed Rate	1	56.98**	0.70**
CF x FR	(2)	2.31	0.40*
CF _L x FR	1	1.46	0.12*
CF _L x FR	1	3.17	0.67**
Error ^Q (b)	3	0.99	0.095
Sub-sub-plots:			
Polymer dosage	(2)	722.63**	0.92**
Linear	1	1,296.39**	1.83**
Quadratic	1	148.87**	0.012
CF x PD	4	73.41**	0.098**
FR x PD	2	5.59	0.11**
CF x FR x PD	4	6.49	0.013
Error (c)	<u>12</u>	3.12	0.060
Total	35		

* Indicates significance at 5% level.

** Indicates significance at 1% level.

Table 26

Effect of Centrifugal Force, Feed Rate, Pool Depth, and Polymer Dosage on Dewatering Return Sludge at the Water Pollution Control Plant, Treasure Island, Florida

Centrifugal Force (Times gravity)	Feed Rate (gpm)	Pool Depth (inches)	Polymer Dosage (lbs/ton)*	Recovery of Suspended Solids Per cent	Cake Solids Per cent				
680	1	0.422	0	33.54 32.62	8.76 8.84				
			4.4	34.81 34.64	8.25 8.20				
			8.8	44.06 45.18	8.03 8.16				
	1	0.594		0	75.76 75.88	5.36 5.39			
				4.4	87.63 88.29	5.56 5.48			
				8.8	94.10 95.78	5.60 5.78			
				1180	1	0.422	0	25.00 24.14	10.23 10.36
							4.4	29.63 29.56	10.52 10.66
							8.8	33.13 31.61	10.24 10.53
1	0.594		0	87.58 86.31	6.07 6.22				
			4.4	96.78 95.66	6.08 6.12				
			8.8	98.33 98.20	6.09 6.18				

Table 26 - Continued

Centrifugal Force (Times gravity)	Feed Rate (gpm)	Pool Depth (inches)	Polymer Dosage (lbs/ton)*	Recovery of Suspended Solids Per cent	Cake Solids Per cent
2880	2	0.594	0	75.72 76.03	6.95 6.81
			4.4	87.08 86.84	6.32 6.24
			8.8	94.90 95.12	6.01 5.88
	3	0.594	0	57.73 58.25	7.62 6.93
			4.4	76.28 74.95	5.44 5.88
			8.8	83.77 84.31	5.17 4.95
	1	0.422	0	0 0	0 0
			4.4	0 0	Trace Trace
			8.8	0 0	Trace Trace
0.594		0	0 0	0 0	
		4.4	77.79 74.88	7.77 8.03	
		8.8	91.41 90.22	7.74 7.68	

* Polymer dosage in pounds per ton dry solids in feed.

Table 26- Continued

Centrifuge operation: Bird 6x12 inch continuous solid bowl centrifuge with countercurrent flow operating at medium and deep pool depths.

Feed properties: Return sludge from a modified contact stabilization plant (process includes primary clarifier).

Total solids = 1.17% SVI = 105 pH = 7.2
 Suspended solids = 0.90% Temperature = 89°F
 Volatile solids = 89.15% Alkalinity = 320 mg/l as CaCO₃

Polymer addition: CAT-FLOC added with centrifuge liquid pool at 0.10 gpm.

Analysis of Variance of Table 26

Source of Variation	Degrees of Freedom	Recovery Mean Square	Cake Solids Mean Square
Main plots:			
Blocks	1	1.20**	0.049**
Centrifugal force (2)		4,552.82**	105.71**
Linear		8,728.64**	172.50*
Quadratic		377.00	38.93
Error (a)	2	1.39	0.010
Sub-plots:			
Feed rate	1	28,712.17**	3.76**
CF x FR	(2)	198.15*	78.57**
CF _L x FR	1	7.37**	137.55**
CF _Q x FR	1	388.92	19.59
Error (b)	3	0.63	0.0033
Sub-sub-plots:			
Polymer dosage	(2)	1,776.62**	6.36**
Linear	1	3,294.49**	9.13**
Quadratic	1	258.74	3.59
CF x PD	(4)	469.37**	7.01**
CF _L x PD _L	1	1,289.23**	20.10**
CF _L x PD _Q	1	395.02	7.27
CF _Q x PD _L	1	192.76**	0.57**
CF _Q x PD _Q	1	0.48	0.11**

Analysis of Variance of Table 26 - Continued

Source of Variation	Degrees of Freedom	Recovery Mean Square	Cake Solids Mean Square
FR x PD	(2)	1044.42**	7.95**
FR x PD _L	1	1731.11**	12.41**
FR x PD _Q	1	357.74**	3.49**
CF x FR x PD	4	685.38	6.33
Error (c)	<u>12</u>	0.40	0.0055
Total	35		

* Indicates significance at 5% level.

** Indicates significance at 1% level.

Table 27

Effect of Deep and Medium Pool Depths, Feed Rate, Polymer Dosage, and Polymer Dosing Rate on Dewatering Return Sludge at the Water Pollution Control Plant, Treasure Island, Florida

Pool Depth (inches)	Feed Rate (gpm)	Polymer Dosage (lbs/ton)	Polymer Dosing Rate (gpm)	Recovery of Suspended Solids Per cent	Cake Solids Per cent
2.50	20	0	---	45.11	7.36
				38.16	7.42
		5	2	86.30	6.96
				79.81	6.67
			4	84.95	6.88
				80.73	6.64
	10	6	79.02	6.55	
			81.85	6.06	
			2	78.46	7.91
		4	85.87	6.76	
			86.52	7.41	
			99.27	6.51	
20	6	98.95	6.82		
		98.75	6.49		
		2	99.22	7.85	
	4	99.94	7.49		
		99.63	7.60		
		99.18	7.68		
30	6	99.02	6.88		
		98.89	6.73		
		2	99.22	7.85	
	4	99.94	7.49		
		99.63	7.60		
		99.18	7.68		
2.50	30	0	---	31.90	7.75
				32.68	7.62
		10	3	84.22	6.53
		83.68	6.67		

Table 27 - Continued

Pool Depth (inches)	Feed Rate (gpm)	Polymer Dosage (lbs/ton)	Polymer Dosing Rate (gpm)	Recover of Suspended Solids Per cent	Cake Solids Per cent
		20	3	99.22 99.30	7.34 6.64
			6	97.79 97.23	5.94 6.01
2.50	40	0	---	27.60 25.39	8.68 8.87
		10		72.24 75.53	6.38 5.92
		20		98.44 97.93	4.75 4.96
		30		99.22 99.10	7.34 7.45
2.00	20	0	---	21.22 18.04	11.37 11.51
		20		68.87 65.33	9.17 9.64
	40	0	---	2.04 0	Trace 0
		40		92.85 89.12	11.07 10.22

Centrifuge operation: Bird 24x38 inch continuous solid bowl centrifuge with countercurrent flow operating at a centrifugal force of 1,335 times gravity.

Feed properties: Return sludge from modified contact stabilization plant (process includes primary clarifier.)

Total solids = 1.21%	SVI = 115	pH = 7.0
Suspended solids = 1.04%	Alkalinity = 375 ^{mb} /l as CaCO ₃	
Volatile solids = 72.10%	Temperature = 88°F	

Polymer addition: Primafloc C-7 added within centrifuge liquid pool.

Analysis of Variance of Table 27

Source of Variation	Degrees of Freedom	Recovery Mean Square	Cake Solids Mean Square
Blocks	1	8.30	0.81
Polymer Dosage		444.63**	0.83**
Linear	1	820.28**	1.59
Quadratic	1	68.98	0.078
Polymer dosing rate		33.02	0.78**
Linear	1	60.21**	1.41
Quadratic	1	5.82*	0.14
PD x PDR		57.21	0.048
PD _L x PDR _L	1	4.93	0.060
PD _L x PDR _Q	1	1.35	0.056
PD _Q x PDR _L	1	22.05**	0.0030
PD _Q x PDR _Q	1	2.05	0.072
Error	8	16.85	0.072
Total	17		

* Indicates significance at 5% level.

** Indicates significance at 1% level.

Table 28

Effect of Centrifugal Force, Feed Rate, and Polymer Dosage on Dewatering Waste Sludge at the Northeast Sewage Treatment Plant, St. Petersburg, Florida

Centrifugal Force (Times gravity)	Feed Rate (gpm)	Polymer Dosage (lbs/ton)*	Recovery of Suspended Solids Per cent	Cake Solids Per cent
680	1	0	38.94	8.86
			36.79	8.96
		10	69.46	7.79
			71.96	7.39
		30	95.26	7.27
			95.53	7.20
		50	98.30	7.09
	99.51		7.34	
	70	99.98	7.85	
		99.48	7.64	
	3	0	31.26	11.73
			29.23	11.79
		10	29.55	9.11
			36.82	9.29
30		77.83	3.52	
		74.38	3.72	
50		89.98	3.70	
	93.30	3.44		
70	91.31	3/55		
	88.26	3.87		
2880	1	0	34.12	11.66
			30.03	11.80
	10	76.10	9.43	
		74.45	9.10	

Table 28 - Continued

Centrifugal Force (Times gravity)	Feed Rate (gpm)	Polymer Dosage (lbs/ton)*	Recovery of Suspended Solids Per cent	Cake Solids Per cent
		30	99.30 98.11	8.66 8.39
		50	99.74 98.88	9.22 9.11
		70	99.87 99.90	9.90 9.88
	3	0	31.18 30.01	11.69 11.75
		10	47.32 44.81	10.10 9.89
		30	81.05 82.76	9.40 9.02
		50	88.13 89.68	8.85 8.91
		70	94.71 96.30	8.46 8.15

* Polymer dosage in pounds per ton dry solids in feed.

Centrifuge operation: Bird 6x12 inch continuous solid bowl with countercurrent flow operating at a deep pool depth (0.594 inches).

Feed properties: Waste sludge from a high rate activated aeration plant.

Total solids = 2.98%	pH = 6.5	Alkalinity = 560 mg/l
Suspended solids = 2.80%		as CaCO ₃
Volatile solids = 78.31%	Temperature = 88°F	
Septic condition	Electrophoretic mobility =	
SCD instrument reading = -2.5	1.8 μ/sec/v/cm	

Polymer addition: CAT-FLOC added within centrifuge liquid pool at 10% of the sludge feed rate.

Analysis of Variance of Table 28

Source of Variation	Degrees of Freedom	Recovery Mean Square	Cake Solids Mean Square
Main plots:			
Blocks	1	0.86	0.076
Centrifugal force	1	117.05	68.15*
Error (a)	1	1.95	0.078
Sub-plots:			
Feed rate	1	2,255.23**	12.85**
CF x FR	1	20.26	10.65**
Error (b)	2	1.21	0.024
Sub-sub-plots:			
Polymer dosage	3	2,782.81**	6.27**
CF x PD	3	33.22**	2.54**
FR x PD	3	291.47**	5.90**
CF x FR x PD	3	11.72	2.54**
Error (c)	<u>12</u>	4.32	0.025
Total	31		

* Indicates significance at 5% level.

** Indicates significance at 1% level.

Table 29

Effect of Polymer Dosage, Polymer Dosing Rate, and Location of Polymer Addition on Dewatering Waste Sludge at the Northeast Sewage Treatment Plant, St. Petersburg, Fla.

Feed Rate (gpm)	Polymer Dosage (lbs/ton) *	Polymer Dosing Rate (gpm)	Location Polymer Added	Recovery of Suspended Solids Per cent	Cake Solids Per cent	Centrate Elec-trophoretic Mobility (μ /sec/v/cm)	Centrate SCD Instrument Reading (μ amps)
1	0	----	---	40.36 38.57	10.74 10.92	-3.0 -2.5	-3.5 -3.3
	40	0.10	In ^a	94.55 95.69	5.92 6.10	-1.7 ---	-0.8 ---
			Out ^b	64.17 71.16	6.89 6.75	-1.5 ---	-1.8 ---
		0.20	In	91.59 89.57	6.14 6.04	-2.0 ---	-2.0 ---
			Out	59.60 55.24	6.93 6.77	-2.0 ---	-2.1 ---
	80	0.10	In	98.57 98.21	6.24 7.04	-1.0 ---	+1.5 ---
			Out	92.61 91.37	6.99 7.20	-1.7 ---	-1.7 ---

Table 29 - Continued

Feed Rate (gpm)	Polymer Dosage (lbs/ton) *	Polymer Dosing Rate (gpm)	Location Polymer Added	Recovery of Suspended Solids		Cake Solids Per cent	Centrate Electrophoretic Mobility (μ /sec/v/cm)	Centrate SCD Instrument Reading (μ amps)
				Per cent	Per cent			
		0.20	In	98.20	7.15	+1.9	+4.1	
				98.21	6.67	---	---	
			Out	85.79	7.63	-2.0	-2.0	
				73.59	6.91	---	---	
2	0	---	---	26.61	10.19			
				25.79	10.03			
		0.20	In	63.85	5.11	-2.0	-3.0	
				63.10	4.67	---	---	
			Out	47.63	7.79	-1.8	-3.4	
				45.29	7.95	---	---	
		0.40	In	50.25	5.08	-2.2	-4.0	
				53.37	4.51	---	---	
			Out	39.06	8.04	-2.3	-4.8	
				41.12	8.16	---	---	
80		0.20	In	71.25	4.32	-1.4	-2.2	
				71.04	4.21	---	---	

Table 29 - Continued

Feed Rate (gpm)	Polymer Dosage (lbs/ton) *	Polymer Dosing Rate (gpm)	Location Polymer Added	Recovery of Suspended Solids Per cent	Cake Solids Per cent	Centrate Electrophoretic Mobility (μ /sec/v/cm)	Centrate SCD ** Instrument Reading (μ amps)
			Out	56.96 54.47	8.05 8.15	-1.9 ---	-2.5 ---
	0.40		In	62.56 57.23	3.99 4.16	-1.5 ---	-2.4 ---
			Out	56.73 50.24	7.94 8.00	-1.9 ---	-3.0 ---

* Polymer dosage in pounds per ton dry solids in feed.

** Streaming Current Detector.

^a Polymer added within centrifuge to liquid pool.

^b Polymer added at discharge side of sludge feed pump.

Centrifuge operation: Bird 6x12 inch continuous solid bowl centrifuge with countercurrent flow operating at a centrifugal force of 680 times gravity and a deep pool depth (0.594 in.).

Feed properties: Waste sludge from a high rate activated aeration plant.

Table 29 - Continued

Total solids = 2.86% pH = 6.3 Alkalinity = 490 mg/l as CaCO₃
Suspended solids = 2.52% Temperature = 87°F
Volatile solids = 74.32% Electrophoretic mobility = -1.8 μ/sec/v/cm
Septic condition SCD instrument reading = -2.5

Polymer addition: CAT-FLOC.

Table 30

Performance of 24 x 60 Inch Centrifuge Dewatering Waste Sludge, St. Petersburg, Fla.^a

Feed Feed Rate (gpm)	Polymer Dosage (lbs/ton) ^b	Recovery of Suspended Solids Per cent	Solids in Cake Per cent
33	0	30.42	9.20
	12.0	71.88	7.60
	16.7 50 C-31 ^c	91.19	8.80
	2.17 65 C-31	93.64	9.60
	25.7 77 C-31	99.59	8.80
	12.0	71.88	7.60
48	0	19.23	10.00
	18.6	39.43	6.80
	23.4	75.64	12.80
	26.8	93.59	8.50
60	0	33.57	8.80

^aResults of follow-up tests conducted by Steve Roach, Engineer, Bird Machine Co. (October, 1967) after installing SW10H Moyno sludge feed pump.

^bPolymer dosage in pounds per ton dry solids in feed.

^cActual polymer dosage used in test. Value was converted to equivalent C-7 dosage (based on 3:1 ratio) for graphing purposes. Polymer dosing rate 9 gpm within centrifuge.

Table 30 - Continued

Centrifuge operation: 1,350 times gravity, deep pool setting No. 2.

Feed properties: Waste sludge high rate activated aeration.

Suspended solids = 2.8% at 33 gpm; 2.0% at 48 gpm.

Alkalinity = 550 mg/l as CaCO_3

Polymer addition: Dosing rate at 9 gpm within centrifuge.

Table 31

Effect Polymer Dosage and Polymer Dosing Rate on Dewatering
Return Sludge at the Northeast Sewage Treatment
Plant, St. Petersburg, Florida

Polymer Dosage (lbs/ton) *	Polymer Dosing Rate (gpm)	Recovery of Suspended Solids Per cent	Cake Solids Per cent
0	---	74.89	5.79
		80.22	5.91
5.9	1.5	88.72	6.09
		87.53	6.40
	3.0	86.63	6.04
		97.26	6.82
	6.0	84.30	4.33
86.35		4.28	
12.0	12.0	79.47	2.24
		81.32	2.29
11.8	1.5	95.52	7.42
		97.66	7.98
	3.0	95.64	7.48
		98.33	7.11
	6.0	6.0	92.97
96.57			6.15
12.0	12.0	78.70	2.73
		86.68	2.91

* Polymer dosage in pounds per ton dry solids in feed.

Centrifuge operation: Bird 24x60 inch continuous solid bowl centrifuge with concurrent flow operating at a centrifugal force of 1,350 times gravity, a deep pool depth, and a sludge feed rate of 60 gpm.

Feed properties: High rate activated aeration return sludge.

Table 31 - Continued

Total solids =	1.01%	SVI =	117	pH =	7.1
Suspended solids =	0.85%	Alkalinity =	401 mg/l as CaCO ₃		
Volatile solids =	85.19%	Temperature =	86° F		

Polymer addition: Primafloc C-7 added within centrifuge liquid pool.

Table 32

Effect of Feed Rate, Pool Depth, Polymer Dosage, and Polymer Dosing Rate on Performance of 24 x 60 Inch Centrifuge Dewatering Return Sludge, St. Petersburg, Florida

Feed Rate (gpm)	Pool Depth Setting ^a	Polymer Dosage (lbs/ton) ^b	Polymer Dosing Rate (gpm)	Recovery of Suspended Solids Per cent	Cake Solids Per cent	
60	#3 1/2	0	---	87.12 87.09	7.17 6.98	
			5	3	91.77 95.74	7.97 6.74
		6		92.96 93.18	6.86 7.97	
				12	84.67 87.01	7.22 7.81
		10			3	99.46 99.75
			6	99.53 99.83		6.89 7.51
	12			99.43 98.84		7.11 6.95
				#3	0	---
			10			99.83
	#4		5	6	94.96	8.09
		10			6	99.89
			80	#3 1/2		0
5					4	
			8			51.93 57.24

Table 32 - Continued

Feed Rate (gpm)	Pool Depth Setting ^a	Polymer Dosage (lbs/ton) ^b	Polymer Dosing Rate (gpm)	Recovery of Suspended Solids Per cent	Cake Solids Per cent
		10	4	90.21 93.00	9.44 9.32
			8	83.15 88.64	9.48 9.02
	#3	10	8	86.20 88.94	2.76 5.03
	#4	10	8	64.45 84.30	9.19 9.28
100	#3 1/2	0	---	55.82 50.53	7.87 8.09
		5	5	47.93 46.67	8.39 8.01
			10	41.35 45.36	8.05 7.92
		10	5	49.94 57.95	10.55 9.26
			10	46.30 55.52	9.42 9.02
		15	10	59.11 ---	10.30 ---
	#3	10	10	46.19 56.75	9.54 9.07
	#4	10	10	45.00 48.97	9.63 9.18

^aPool depth settings.

#4 - Maximum depth without centrate discharge with cake (Approximately 2.25 inches).

Table 32 - Continued

#3 1/2 - Some centrate discharged with cake.

#3 - More centrate discharged with cake.

^b Polymer dosage in pounds per ton dry solids in feed.

Centrifuge operation: Bird 24x60 inch continuous solid bowl with concurrent flow operating at 1350 times gravity, gear ratio 140:1.

Feed properties: Return activated sludge from high rate activated aeration process.

Total solids = 0.92%	SVI = 110	pH = 7.0
Suspended solids = 0.77%	Alkalinity = 385 mg/l as CaCO ₃	
Volatile solids = 86.06%	Temperature = 80°F	

Polymer addition: Primafloc C-7 added within centrifuge liquid pool.

Analysis of Variance of Table 32

Source of Variation	Degrees of Freedom	Recovery Mean Square	Cake Solids Mean Square
Main plots:			
Blocks	1	93.96	0.26
Feed rate	(2)	6,760.27**	4.49
Linear	1	13,519.46**	8.12
Quadratic	1	1.09	0.81
Error (a)	2	12.83	
Sub-plots:			
Polymer dosage	1	2,259.10	6.73**
FR x PD	(2)	547.48	2.10**
FR _L x PD	1	1.72	2.67**
FR _Q x PD	1	1,093.25**	1.54**
Polymer dosing rate	(2)	113.06**	1.55**
Linear	1	210.76**	3.09**
Quadratic	1	15.36	0.013
FR x PDR	(4)	10.01	0.23
FR _L x PDR _L	1	0.028	0.65
FR _L x PDR _Q	1	10.46	0.00087

Analysis of Variance of Table 32- Continued

Source of Variation	Degrees of Freedom	Recovery Mean Square	Cake Solids Mean Square
FR _Q x PDR _L	1	17.88	0.050
FR _Q x PDR _L FR _Q x PDR _Q	1	11.60	0.21
PD x PDR	(2)	8.82	0.43
PD x PDR _L	1	17.43	0.78
PD x PDR _L PD x PDR _Q	1	0.22	0.090
FR x PD x PDR	4	4.38	0.23
Error (b)	<u>15</u>	4.53	0.18
Total	35		

* Indicates significance at 5% level.

** Indicates significance at 1% level.

Table 33

Effect of Centrifugal Force, Polymer Dosage, and Location of Polymer Addition on Dewatering Raw Sludge at the University of Florida Sewage Treatment Plant

Centrifugal Force (Times gravity)	Polymer Dosage (lbs/ton)*	Location Polymer Added	Recovery of Suspended Solids Per cent	Cake Solids Per cent
1180	0	--	50.76	11.83
			69.26	11.28
	5	In ^a	76.41	11.04
			80.78	10.96
			After ^b	12.96
		Before ^c	71.68	13.66
			73.03	
			69.98	12.89
	10	In	71.73	13.03
			77.68	11.68
			74.47	12.04
		After	69.68	12.45
68.14			12.09	
Before			12.01	
2880	0	--	66.19	18.67
			63.73	18.04
	5	In	76.52	25.88
			76.93	21.25
			After	13.96
		Before	71.69	15.01
			74.14	
			74.60	12.73
	10	In	74.54	12.17
			75.09	13.00
			32.15	12.68

Table 33 - Continued

Centrifugal Force (Times gravity)	Polymer Dosage (lbs/ton)*	Location Polymer Added	Recovery of Suspended Solids Per Cent	Cake Solids Per cent
		After	69.21 71.78	14.79 13.62
		Before	68.93 69.04	13.91 13.90

* Polymer dosage in pounds per ton dry solids in feed.

^a Polymer added within centrifuge to liquid pool.

^b Polymer added at discharge side of sludge feed pump.

^c Polymer added at suction side of sludge feed pump.

Centrifuge operation: Bird 6x12 inch continuous solid bowl centrifuge with countercurrent flow operating at a deep pool depth (0.594 inches) and a sludge feed rate of 1 gpm.

Feed properties: Raw sludge

Total solids =	0.51%	pH =	5.7	Alkalinity =	67
Suspended solids =	0.38%	Temperature =	86° F		
Volatile solids =	80.68%	Electrophoretic mobility =	1.6	/sec/v/cm	

Polymer addition: Furifloc A-21 added at 0.10 gpm.

Table 34

Effect of Feed Rate, Polymer Dosage, and Location Polymer
Added on Dewatering Raw Sludge at the Water
Pollution Control Plant, Treasure Island, Florida

Feed Rate (gpm)	Polymer Dosage (lbs/ton) *	Location Polymer Added	Recovery of Suspended Solids Per cent	Cake Solids Per cent
10	0	--	90.22	13.46
			92.76	13.02
	5.5	In	98.68	12.10
			99.41	11.88
		Out	99.56	11.39
			97.98	12.22
	11.0	In	98.96	16.51
			99.07	14.67
Out		99.29	10.97	
		99.17	11.34	
15	0	--	75.42	15.42
			73.10	15.77
	5.5	In	95.66	12.97
			94.48	13.01
		Out	90.83	13.83
			88.68	14.08
	11.0	In	98.76	13.42
			99.23	13.13
Out		95.84	14.47	
		95.78	14.11	
20	0	--	58.62	17.23
			55.75	17.55
	5.5	In	72.16	16.11
			76.39	15.81

Table 34 - Continued

Feed Rate (gpm)	Polymer Dosage (lbs/ton)*	Location Polymer Added	Recovery of Suspended Solids Per cent	Cake Solids Per cent
	11.0	In	86.31 80.58	15.05 15.96
		Out	69.81 66.12	16.27 16.87

* Polymer dosage in pounds per ton dry solids in feed.

Centrifuge operation: Bird 24x38 inch continuous solid bowl centrifuge with countercurrent flow operating at a centrifugal force of 1,335 times gravity and a maximum pool depth (2.50 inches).

Feed properties: Raw sludge.

Total solids = 4.77%	pH = 6.8
Suspended solids = 4.56%	Alkalinity = 117 mg/l as CaCO ₃
Volatile solids = 83.21%	Temperature = 84°F

Polymer addition: Primafloc C-7 added at 10% of the sludge feed rate.

Analysis of Variance of Table 34

Source of Variation	Degrees of Freedom	Recovery Mean Square	Cake Solids Mean Square
Blocks	1	4.49	0.00020
Feed rate	2	1,640.79**	26.13**
Polymer dosage	1	92.67**	1.66*
FR x PD	2	21.97**	1.49*
Location polymer added	1	196.65**	0.17
FR x LPA	2	86.02**	6.90**
PD x LPA	1	1.08	2.29*

Analysis of Variance of Table 34 - Continued

Source of Variation	Degrees of Freedom	Recovery Mean Square	Cake Solids Mean Square
FR x PD x LPA	2	7.33	3.43**
Error	<u>11</u>	3.03	0.26
Total	23		

*Indicates significance at the 5% level.

**Indicates significance at the 1% level.

APPENDIX 2

GLOSSARY

APPENDIX 2

GLOSSARY

1. Flocculation: the aggregation of finely divided or colloidal particles into larger particles and loosely bound masses.
2. Experiment: the whole set of trials (test runs) carried out, not an individual trial.
3. Test run: an individual trial or the accomplishing of one treatment combination.
4. Variable: a factor which has a series of values or levels.
5. Response: the numerical result of an observation made with a particular treatment combination.
6. Polymer dosage: the pounds of polymer as received (liquid or or solid) from the manufacturer per ton of dry solids in the sludge feed expressed as lbs/ton.
7. Polymer dosing rate: the volumetric rate of adding a polymer solution to a sludge.
8. Polymer: professional jargon used for the term "polyelectrolyte."
9. In: the addition of the polymer within the centrifuge.
10. Out: the addition of the polymer to the sludge outside the centrifuge.
11. Recovery: the proportion of the suspended solids in the feed sludge sedimented expressed as a percentage.

12. **Cake solids:** the concentration of total solids in the cake product expressed as a percentage.

13. **SCD: Streaming Current Detector,** an instrument for determining the sign and a quantity proportional to the electrical charge density on colloidal particles.

LIST OF REFERENCES

1. Chase, Sherman, E. "Nine Decades of Sanitary Engineering - Part II, Developments Since World War I." Water Works and Wastes, 2:51 (1965).
2. Glass, A.C., and Jenkins, K. H. "Statistical Summary of 1962 Inventory of Municipal Waste Facilities in the United States." USPHS Publ. No. 1165, U. S. Govt. Printing Office, Washington, D.C., 1964.
3. Cohn, Morris M. Sewers for Growing America. Certain-teed Products Corp., Ambler, Pennsylvania, 1966.
4. Newton, D. "Thickening by Gravity and Mechanical Means." Sludge Concentration, Filtration and Incineration. University of Michigan School of Public Health, Cont. Ed. Ser. 113:4 (1964).
5. McCarty, Perry L. "Sludge Concentration - Needs, Accomplishments, and Future Goals." Jour. WPCF, 38:493 (1966).
6. Torpey, W. N. "Concentration of Combined Primary and Activated Sludge in Separate Thickening Tanks." ASCE Proceedings, 80:443 (1954).
7. Kennedy, R. R. "Thickening by Elutriation and Chemical Coagulation." Sludge Concentration, Filtration, and Incineration. University of Michigan School of Public Health, Cont. Ed. Ser. 113:37 (1964).
8. Katz, William J., and Geinopolos, Anthony. "Sludge Thickening by Dissolved-Air Flotation." Jour. WPCF, 39:946 (1967).
9. Eckenfelder, W. W., Jr., et al. "Studies on Dissolved Air Flotations of Biological Sludges." Biological Treatment of Sewage and Industrial Wastes, Vol. II, Anaerobic Digestion and Solids-Liquid Separation. Edited by Brother Joseph McCabe and W. W. Eckenfelder, Jr. New York: Reinhold Publishing Corp., 1958.
10. Ettelt, Gregory A., and Kennedy, Thomas J. "Research and Operational Experience in Sludge Dewatering at Chicago." Jour. WPCF, 38:248 (1967).
11. Smith, Jullian C. "Centrifugation Equipment Applications." Industrial and Engineering Chemistry, 53:439 (1961).
12. White, William F., and Burns, Thomas E. "Continuous Centrifugal Treatment of Sewage Sludge." Water & Sewage Works, 109:384 (1962).

13. Radcliffe, Harold. "Dual-Purpose Centrifuging at Treasure Island, Florida." Water and Wastes Engineering, 3:87 (1966).
14. Schaffer, Robert B. "Polyelectrolytes in Industrial Waste Treatment." Presented at the 18th Annual Industrial Waste Conference, Purdue University, April 30, 1963.
15. Quon, Jimmie E. and Johnson, Glenn M. "Drainage Characteristics of Digested Sludge." ASCE Sanitary Engineering Division, ASCE Proceedings, 92,SA2:67 (1966).
16. "Sludge Lagoons." Committee Report. Sewage Works Jour., 20:5 (1949).
17. Trubnick, Eugene H., and Mueller, Peter K. "Vacuum Filtration Principles and Their Application to Sewage Sludge Dewatering." Biological Treatment of Sewage and Industrial Wastes, Vol. II, Anaerobic Digestion and Solids-Liquid Separation. Edited by Brother Joseph McCabe and W. W. Eckenfelder, Jr. New York: Reinhold Publishing Corp., 1958.
18. Starcosa G.m.b.H and Co. "Verarbeitung von Frisch - oder Faulschlamm mit biologischer Behandlung des Zentrifugates." Information Sheet No. KS 23d, Wunstorf-Hannover, 1966.
19. White, William F. "Centrifugal Filtration of Digested Sludge." Water and Sewage Works, 106:515 (1959).
20. White, William F. "Centrifugal Treatment of Industrial Waste Waters." Industrial Water and Wastes, 11:40 (1963).
21. Amero, C. L., and Bosworth, O. W. "Continuous Centrifugal Dewatering of Waste Sludges." Sludge Concentration, Filtration, and Incineration. University of Michigan School of Public Health, Cont. Ed. Ser. 113: 139 (1964).
22. Bradney, Leland, and Bragstad, R. E. "Concentration of Activated Sludge by Centrifuge." Sewage & Industrial Wastes, 27:404 (1955).
23. Jenks, John H. "Continuous Centrifuging Used to Dewater Variety of Sludges." Wastes Engineering, 29:360 (1958).
24. Keith, Frederick W., Jr. "The Use of Centrifuges in Disposal of Solids From Wastes." Presented at 33rd Annual Meeting Pacific Northwest Pollution Control Association, Portland, Oregon, October 19-22, 1966.
25. Landis, D. M. "Centrifugal Coalescers." Chemical Engineering Progress, 61:58 (1965).
26. Parkhurst, John D., and Sanders, S. R. "Centrifuging and Screening of Sludge." Water & Waste Treatment, 9:596 (1964).

27. Bramford, Robert A. "Centrifugal Dewatering of Paper Mill Waste." Tappi, 47:187A (1964).
28. Montanero, William J. "Sludge Dewatering by Centrifuges - Recent Operating Experiences." Presented at 37th Annual Conference of Water Pollution Control Assoc. of Penn., Penn State University, August 5, 1965.
29. Montanero, William J. "Centrifuging Waste Solids - Industrial Waste Applications." Presented at 38th Annual Conference of Water Pollution Control Federation, Atlantic City, New Jersey, October 13, 1965.
30. Montanero, William J. "Developments in Sludge Dewatering - Solid Bowl Centrifuges." Presented at 14th Annual Meeting Ohio Water Pollution Control Conference, Columbus, Ohio, June 8, 1966.
31. Griffin, Guy E., and Brown, James M. "Studies on Concentrating Digested Sludge Prior to Barging." Jour. WPCF, 38:996 (1966).
32. Millward, Richard S. and Darby, W. Allen. "Sludge Disposal by Dewatering and Combustion." Water and Wastes Engineering, 4:64 (1967).
33. Stevens, Martin H. "Dewatering Sludges and Slurries by Centrifugation." Presented at Water Pollution Control Federation Conference, Kansas City, Missouri, September, 1966.
34. Keefer, C. E., and Kratz, Herman, Jr. "Experiments on the Dewatering of Sewage Sludge With a Centrifuge." Sewage Works Jour., 1:120 (1929).
35. Maffei, J. A. Unsere Zentrifugen zur Schlamm-trocknung in stadtischen Klaranlagen. Munich, Germany, 1930.
36. "The Centrifuge and Sewage Sludge." Sewage Works Jour., Editorial, 1:246 (1929).
37. Pecker, Jos. S. "Centrifugals." Sewage Works Jour., 8:991 (1936).
38. Kraus, L. S., and Longley, J. R. "Concentrating Activated Sludge With a Continuous Feed Centrifuge." Sewage Works Jour., 11:10 (1939).
39. Strezynski, G. J. "Discussion on Mr. Kraus' Paper on the Use of High Speed Centrifuge for Concentration of Activated Sludge at Peoria, Illinois." Sewage Works Jour., 11:21 (1959).
40. Kless, F. "Entwicklung und Stand der Schlammbehandlung in der Bundesrepublik Deutschland." Kommunalwirtschaft, H9:370 (1963).
41. Bradney, Leland, and Bragstad, R. E. "Concentration of Activated Sludge by Centrifuge." Sewage and Industrial Wastes, 27:404 (1955).

42. Hamlin, G. H. "Super-Rate Biological Filter." Industrial Water and Wastes, 10:148 (1962).
43. Ambler, Charles M. "Centrifugation Equipment Theory." Industrial and Engineering Chemistry, 53:429 (1961).
44. Ambler, Charles M. "The Evaluation of Centrifuge Performance." Chemical Engineering Progress, 48:150 (1952).
45. Frampton, G. A. "Evaluating the Performance of Industrial Centrifuges." Chemical and Process Engineering, 59:402 (1963).
46. Trowbridge, M. E. O'K. "Problems in the Scaling-Up of Centrifugal Separation Equipment." Chemical Engineer, 69:A73 (1962).
47. Lavonchy, A. C., and Keith, F. W., Jr. "Centrifugal Separation." Kirk-Othmer Encyclopedia of Chemical Technology. 1st ed., 4:710 (1960).
48. Rudolfs, William, and Balmat, J. L. "Colloids in Sewage." Sewage and Industrial Wastes, 24:247 (1952).
49. Moyers, Charles, G., Jr. "How to Approach a Centrifugation Problem." Chemical Engineering, 72:182 (1966).
50. Genter, A. L. "Computing Coagulant Requirements in Sludge Conditioning." Transactions ASCE, 111:637 (1946).
51. Van Kleeck, Leroy W. "Operation of Vacuum Filters." Sludge Concentration, Filtration, and Incineration. University of Michigan School of Public Health, Cont. Ed. Ser. 113:105 (1964).
52. Bargman, R. D.; Garber, William F.; and Nayano, Joe. "Sludge Filtration and Use of Synthetic Organic Coagulants at Hyperion." Sewage & Industrial Wastes, 30:1079 (1958).
53. Hunter, J. V. and Heukelekian, H. "The Composition of Domestic Sewage Fractions." Jour. WPCF, 37:1142 (1965).
54. Thompson, Robert N.; Zajic, James E.; and Lichti, E. "Spectrographic Analysis of Air-Dried Sewage Sludge." Jour. WPCF, 36:752 (1964).
55. Balmat, J. L. "Chemical Composition and Biochemical Oxidation of Particulate Fractions in Domestic Sewage." Unpublished Dissertation, Rutgers University, New Brunswick, New Jersey, 1955.
56. Weisberg, E. "Dispersion and Aggregation of Sewage Colloids and Hydration of Sewage Sludges." Unpublished Dissertation, Rutgers University, New Brunswick, New Jersey, 1955.

57. Kennedy, Thomas J.; Ettelt, Gregory A.; and Kaplovsky, A. Joel. "Effect of Centrate from a Solid Bowl Centrifuge on Activated Sludge Process." Presented at 22nd Industrial Waste Conference, Purdue University, May, 1967.
58. Brewster, Ray Q. and McEwen, William E. Organic Chemistry, A Brief Course. Englewood Cliffs, New Jersey: Prentice Hall, Inc., 1963.
59. Rich, Linvil G. Unit Process of Sanitary Engineering. New York: John Wiley & Sons, 1963.
60. Weiser, Harry Boyer. Colloid Chemistry. New York: John Wiley & Sons, Inc., 1949.
61. Priesing, C. P. "A Theory of Coagulation Useful for Design." Industrial & Engineering Chemistry, 54:38 (1962).
62. Bier, M. and Frederick, C. Cooper. "Electrical Phenomena at Surfaces." Principles and Applications of Water Chemistry. Edited by Samuel D. Faust and Joseph V. Hunter. New York: John Wiley & Sons, 1967.
63. Maron, Samuel A. and Prutton, Carl F. Principles of Physical Chemistry. New York: The Macmillan Company, 1961.
64. La Mer, Victor K. "Coagulation Versus the Flocculation of Colloidal Dispersions of High Polymers (Polyelectrolytes)." Principles and Applications of Water Chemistry. Edited by Samuel D. Faust and Joseph V. Hunter. New York: John Wiley & Sons, 1967.
65. Black, A. P. "Theory of Coagulation." Collected Works of A. P. Black. Compiled by J. E. Singley and Ching-lin Chen. Gainesville, Florida, 1966.
66. Black, A. P. and Smith, Annie L. "Determination of the Mobility of Colloidal Particles by Microelectrophoresis." Jour. AWWA, 54:926 (1962).
67. Riddick, Thomas M. Zeta-Meter Manual. New York: Zeta-Meter, Inc., 1961.
68. Gerdes, Walter F. A New Instrument, The Streaming Current Detector. Freeport, Texas: The Dow Chemical Company, 1967.
69. Brey, Wallace S., Jr. Principles of Physical Chemistry. New York: Appleton-Century-Crafts, Inc., 1958.
70. Black, A. P. "Basic Mechanisms of Coagulation." Jour. AWWA, 52:492 (1960).
71. O'Driscoll, Kenneth F. The Nature and Chemistry of High Polymers. New York: Reinhold Publishing Corp., 1964.

72. Discussion following paper presented by Victor K. La Mer. "Coagulation Versus the Flocculation of Colloidal Dispersions by High Polymers (Polyelectrolytes)." Principles and Applications of Water Chemistry. Edited by Samuel D. Faust and Joseph V. Hunter. New York: John Wiley & Sons, 1967.
73. Birkner, Francis B. "The Destabilization of Dilute Clay Suspensions With Labelled Polymers." Unpublished Dissertation, University of Florida, August, 1965.
74. Jones, Richard H. "Liquid-Solids Separation in Domestic Waste With a Cationic Polyelectrolyte." Unpublished Dissertation, University of Florida, December, 1966.
75. Colorimetric Determination of Conductive Polymer 261 in Water and in Sensitized Papers. Calgon Chemical Application Bulletin 7-24, Calgon Corporation, 1966.
76. Standard Methods for the Examination of Water and Waste Water. APHA, AWWA, and WPCF. 12th ed. New York, 1965.
77. Wyckoff, Bruce M. "Rapid Solids Determination Using Glass Fiber Filters." Water and Sewage Works, 111:277 (1964).
78. Smith, Arnold L. and Greenberg, Arnold E. "Evaluation of Methods for Determining Suspended Solids in Wastewater." Jour. WPCF, 35:940 (1963).
79. Jenkins, D. "An Improved Volatile Suspended Solids Method." Water and Wastes Treatment, 9:66 (1962).
80. Streaming Current Detector Manual. Waters Associates, Framingham, Mass., 1967.
81. Letter from J. P. Kleber, Calgon Corporation Polymer Dept. to A. P. Black, September 28, 1967.
82. Parsons, William A. Chemical Treatment of Sewage and Industrial Wastes. National Lime Association, Washington, D. C., 1965.
83. Eckenfelder, W. W., Jr. and O'Connor, D. J. Biological Waste Treatment. New York: Pergamon Press, 1964.
84. Snedecor, George W. Statistical Methods. Ames, Iowa: Iowa State University Press, 1956.
85. Davies, Owen L. The Design and Analysis of Industrial Experiments. New York: Hafner Publishing Company, 1963.

86. Peng, K. C. The Design and Analysis of Scientific Experiments. Reading, Mass.: Addison-Wesley Publishing Company, 1967.
87. Heukelekian, H., and Weisburg, E. "Bound Water and Activated Sludge Bulking." Sewage and Industrial Wastes, 28:558 (1956).
88. Tenny, Mark W., and Stumm, Werner. "Chemical Flocculation of Microorganisms in Biological Waste Treatment." Paper presented at the 19th Industrial Waste Conference, Purdue University, 1963.
89. Flood, J. E., Porter, H. F., and Rennie, F. W. "Centrifugation Equipment." Chemical Engineering, 73:190 (1966).

BIOGRAPHICAL SKETCH

Sterling Eugene Schultz, Major, USAF, was born June 11, 1934, at Homer, Nebraska. In June, 1952, he was graduated from North Phoenix High School, Phoenix, Arizona. He received the degree of Bachelor of Science with a major in Civil Engineering from the University of Arizona in June, 1957. After graduation he worked for Babcox & Wilcox Company, Barberton, Ohio, until he was called into active duty with the United States Air Force as a 2nd Lieutenant. He served as a civil engineer for three years at Ladd Air Force Base, Fairbanks, Alaska, where he gained extensive experience in structural engineering and his work took him throughout the state of Alaska -- even to "Station Charlie," a floating scientific ice island in the Arctic Ocean.

In January, 1961, the Air Force sent him back to the University of Arizona where he earned a Master of Science Degree with a major in structural engineering. Upon graduation in June, 1962, he was selected to be an Instructor at the United States Air Force Academy beginning in June, 1963. During the intervening year he served as a field engineer, supervising the construction of Minuteman Missile Sites surrounding Great Falls, Montana.

He began his teaching profession in June, 1963, at the Air Force Academy, Colorado Springs, Colorado. After teaching for two years he was encouraged and sponsored by the Civil Engineering Department to return to graduate school for his doctorate degree. At the present time he is on leave of absence from the United States Air Force Academy for advanced

study in Environmental Engineering at the University of Florida.

He is married to the former Shirlee Mae Menefee and is the father of two sons, Shane Edward and Stanton Sterling.

He is a Nazarene, a member of the American Society of Civil Engineers, the Water Pollution Control Federation, and Tau Beta Pi.

This dissertation was prepared under the direction of the chairman of the candidate's supervisory committee and has been approved by all members of that committee. It was submitted to the Dean of the College of Engineering and to the Graduate Council, and was approved as partial fulfillment of the requirements for the degree of Doctor of Philosophy.

December 19, 1967

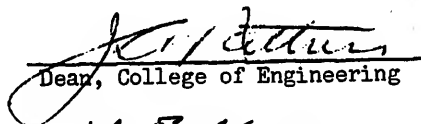
Dean, College of Engineering

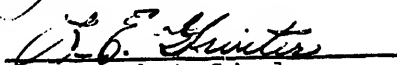

Dean, Graduate School

Supervisory Committee:

Chairman



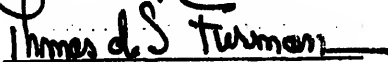



UNIVERSITY OF FLORIDA



3 1262 08666 428 0