



This is a digital copy of a book that was preserved for generations on library shelves before it was carefully scanned by Google as part of a project to make the world's books discoverable online.

It has survived long enough for the copyright to expire and the book to enter the public domain. A public domain book is one that was never subject to copyright or whose legal copyright term has expired. Whether a book is in the public domain may vary country to country. Public domain books are our gateways to the past, representing a wealth of history, culture and knowledge that's often difficult to discover.

Marks, notations and other marginalia present in the original volume will appear in this file - a reminder of this book's long journey from the publisher to a library and finally to you.

Usage guidelines

Google is proud to partner with libraries to digitize public domain materials and make them widely accessible. Public domain books belong to the public and we are merely their custodians. Nevertheless, this work is expensive, so in order to keep providing this resource, we have taken steps to prevent abuse by commercial parties, including placing technical restrictions on automated querying.

We also ask that you:

- + *Make non-commercial use of the files* We designed Google Book Search for use by individuals, and we request that you use these files for personal, non-commercial purposes.
- + *Refrain from automated querying* Do not send automated queries of any sort to Google's system: If you are conducting research on machine translation, optical character recognition or other areas where access to a large amount of text is helpful, please contact us. We encourage the use of public domain materials for these purposes and may be able to help.
- + *Maintain attribution* The Google "watermark" you see on each file is essential for informing people about this project and helping them find additional materials through Google Book Search. Please do not remove it.
- + *Keep it legal* Whatever your use, remember that you are responsible for ensuring that what you are doing is legal. Do not assume that just because we believe a book is in the public domain for users in the United States, that the work is also in the public domain for users in other countries. Whether a book is still in copyright varies from country to country, and we can't offer guidance on whether any specific use of any specific book is allowed. Please do not assume that a book's appearance in Google Book Search means it can be used in any manner anywhere in the world. Copyright infringement liability can be quite severe.

About Google Book Search

Google's mission is to organize the world's information and to make it universally accessible and useful. Google Book Search helps readers discover the world's books while helping authors and publishers reach new audiences. You can search through the full text of this book on the web at <http://books.google.com/>

DIAGNOSTICS
OF
AURAL DISEASE.

—
S.E. SMITH.



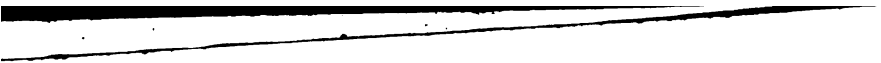



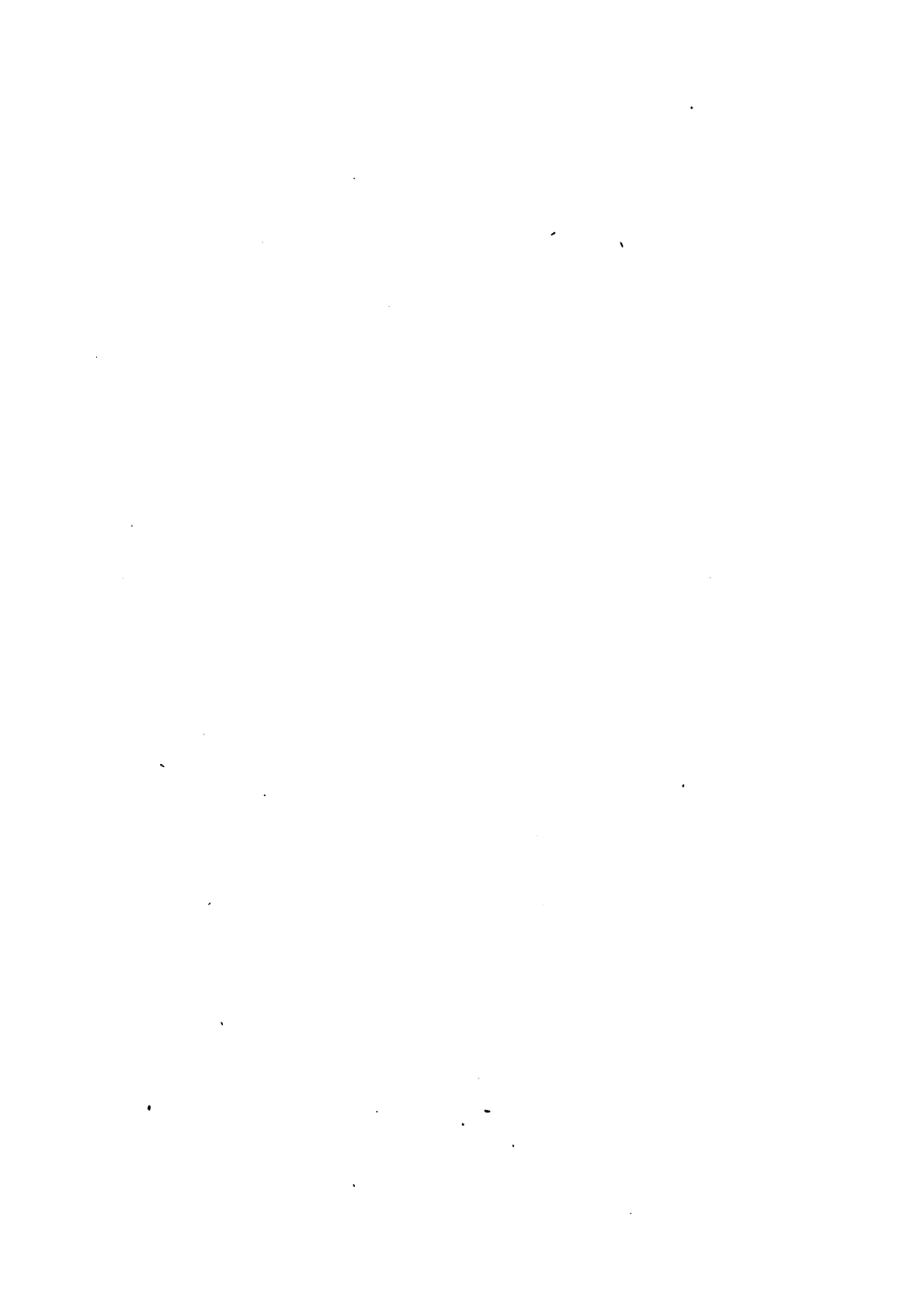

AURAL DISEASE

J. WRIGHT AND CO.,
"THE BRISTOL STEAM PRESS,"
STEPHEN STREET.



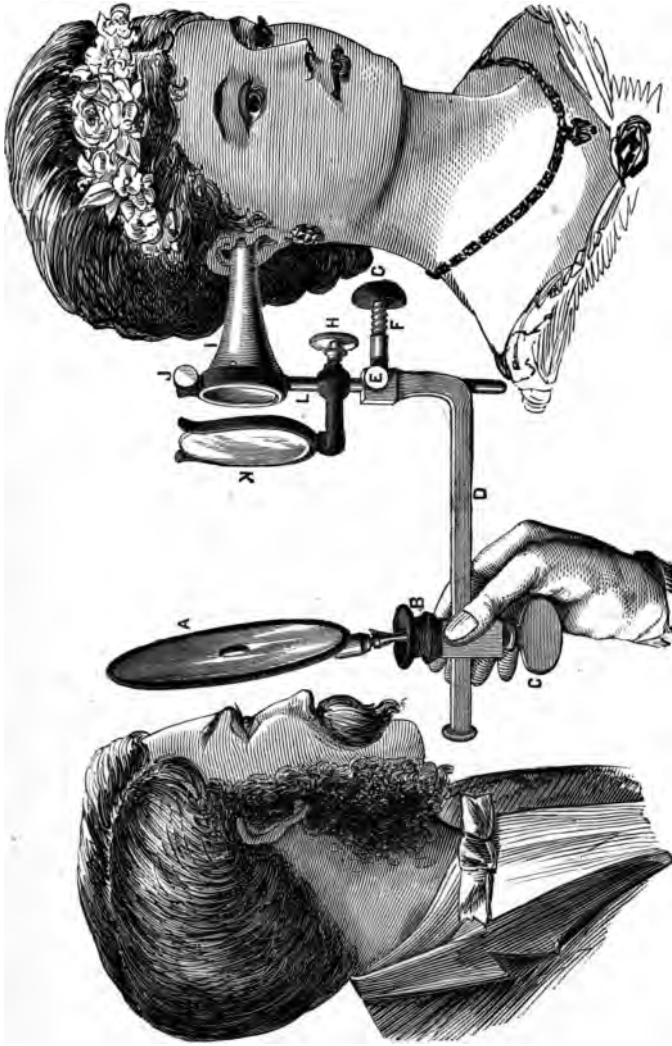

A. Reflector. B. Ball and Socket Joint to enable the operator to place Reflector in any position. C. Nut to fasten Joint to Sliding Bar. D. Sliding Bar. E. Flexible Joint. F. G. Spiral Spring and Nut to regulate Flexible Joint. H. Nut to fasten Reflector on Perpendicular Bar. I. Speculum. J. Speculum. K. Lens. L. Sliding Perpendicular Bar to regulate position of Lens. The Surgeon must bear in mind that he will require to adjust each part, and to focus the Lens to suit the case under examination.

DIAGNOSTICS
OF
AURAL DISEASE

BY

S. E. SMITH, ESQ., M.R.C.S. ENG.

Surgeon to the late National Ear Institution, London.

AUTHOR OF A PRACTICAL TREATISE UPON 'DEAFNESS AND DISEASES OF THE EAR,' ALSO 'THE INFLUENCE OF TRADES UPON THE ORGAN OF HEARING.' INVENTOR OF THE INSTRUMENT FOR THE APPLICATION OF GASES, VAPOURS, AND CHLOROFORM TO VARIOUS ORGANS IN THE HUMAN BODY; AND OF THE ELECTRIC EUSTACHIAN CATHETER, FOR THE INTRODUCTION OF THE ELECTRIC CURRENT TO THE MIDDLE EAR.

WITH ILLUSTRATIONS ON WOOD.

Second Edition

LONDON

BAILLIÈRE, TINDALL & COX, KING WILLIAM STREET, STRAND.

PARIS

J. B. Baillière et fils, Rue Hautefeuille.

MADRID

Bailly-Baillière, Calle del Principe

1873.

160. e. 112.



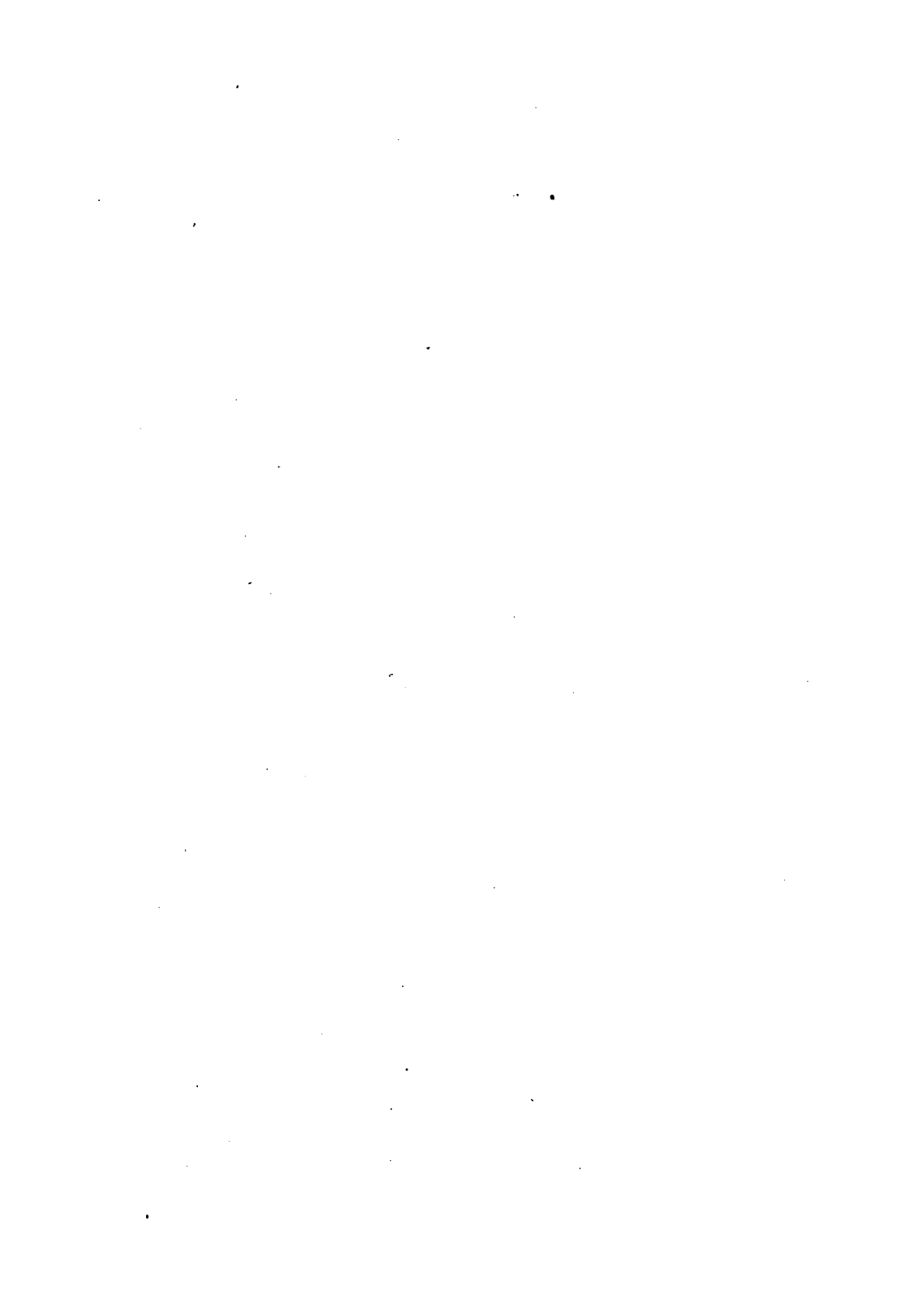

P R E F A C E
TO THE
F I R S T E D I T I O N .

IT will afford some compensation for the task of perusal to find that prolix apology is not offered, nor egotistical enumerations made of the sacrifice of time and labour through which this little volume is presented to the public. Were it necessary I should detail my reasons for this adventure, they might be disposed of summarily in the affirmation that I have had in view the diffusion of a more general knowledge of the diseases of the ear, and of the errors connected with aural practice. How far I have realised such an object the following pages must be my testimony.

I revert with pleasure to the advantage which I have gained from the various interesting cases which have been placed under my care by professional gentlemen, who will accept this as a record of my thanks for their confidence, and an acknowledgment of the service they have rendered me.

SAMUEL E. SMITH,
SCARBOROUGH.

(Late of 21 Langham Place, Regent Street, London, W.)



P R E F A C E
TO THE
S E C O N D E D I T I O N .

I E M B R A C E the opportunity afforded me in introducing a second edition to bring some of the results of my investigations and experience in the use of medical electricity in some forms of aural disease before the notice of the medical public at large ; and to describe my newly invented instruments, the Electro Eustachian Catheter for the application of the electric current into the internal ear ; the Electro Conductor for the external ear and outer surface of the membrana tympani ; and the Throat Conductor, forming a complete set for the treatment of those diseases of the ear in which electricity is of service. In the chapter on electricity will be found a description of other instruments I have invented for all the internal organs of the body.

I cannot sufficiently thank my medical friends for the great kindness and sympathy extended to me during my long illness ; having now perfectly recovered my health I have resumed my professional duties, and decided to reside permanently in Scarborough.

SAMUEL E. SMITH,

January, 1873.

Westborough Villa, Scarborough.



CONTENTS.

INTRODUCTION Page 1—3

CHAPTER I.

SOUND ; ITS TRANSMISSION, VELOCITY, AND INTENSITY.

The Ear as an Apparatus for the Transmission of External Vibrations to the Brain 4—6

CHAPTER II.

ANATOMY OF THE EAR.

The Auricle in Man ; in Animals.—Its Adaptation for collecting Sounds.—Its Muscles.—The External Auditory Passage.—Introduction of foreign Bodies.—The Tympanum.—The Mastoid Cells.—The Eustachian Tube.—The Membrana Tympani.—Ossicula Auditûs.—The Vestibule.—The Semi-circular Canals.—The Cochlea.—The Auditory Nerve 7—16

CHAPTER III.

PHYSIOLOGY OF THE EAR.

The Functions of the Auricle : of the Concha.—Dr. Carpenter on the Concha.—The Development of Muscles.—Functions of the Auditory Canal.—Functions of the Tympanum.—Air of the Tympanum.—Its Action upon the Membrana Tympani.—Upon the Chain of Bones.—Upon Fenestra Ovalis.—Fluid of Labyrinth.—Filaments of the Auditory Nerve.—Functions of the Cochlea.—Functions of the Semi-circular Canals.—M. Flourens on Semi-circular Canals.—The Auditory Nerve.—Experiments on Dogs 17—24

CHAPTER IV.

DISEASES OF THE AURICLE AND EXTERNAL AUDITORY PASSAGE.

Acute Erysipelas of the Auricle.—Symptoms and Termination.—Cases.—Cutaneous Diseases.—Eczema.—Herpes,—Scrofulous Ulcers.—Encysted Tumours.—Hypertrophy: Case.—Frost Bite.—Wounds and Injuries.—Cases.—Abscesses.—The Speculum.—Author's Speculum.—Examination of the Auditory Passage.—Inflammation of the External Auditory Passage.—Acute: Chronic, and Treatment.—Tinnitus Aurium.—Cases.—Abscesses: Acute and Chronic.—Gases.—Ulcers.—Their Consequences if neglected.—Treatment.—Syphilitic Ulcers Page 25—47

CHAPTER V.

POLYPI.

Instrument used in the Extraction of Polypoid Growths.—Woodcut of Instrument.—Polypoid Growths: Cases.—Cancerous Tumours.—Case recorded by Mr. Wilde.—Diseases of the Ceruminous Glands.—Accumulation of Wax: Case.—Effect on Membrana Tympani: Case.—Deficiency in the Secretion of the Glands: Treatment.—Foreign Bodies.—The Use of the Syringe 48—62

CHAPTER VI.

DISEASES OF THE MEMBRANA TYMPANI.

Inflammation: Acute.—Symptoms.—Termination.—Treatment.—Cases.—Chronic Inflammation.—Nerve Pain, or Neuralgia of the Ear.—Treatment.—Nervous Deafness.—Treatment of Chronic Inflammation: Cases.—Thickening.—Perforation.—Artificial Membrana Tympani.—Otorrhoea: Treatment.—Cases 63—81

CHAPTER VII.

DISEASES OF THE TYMPANUM.

Acute Inflammation of the Lining Membrane: Symptoms.—Results.—Treatment.—Cases.—Chronic Inflammation.—Cases.—Eustachian Tube: Functions.—Obstruction.—Enlarged Tonsils.—Throat Deafness.—Removal of Tonsils.—Catheterism.—Manner of passing the Catheter.—Instrument for Application of Vapours, &c.—The Ossicula Auditûs.—Mastoid Cells.—Polypoid Growths.—Mercurial Preparations.—Hyd. c. Cretâ.—Calomel.—The Bichloride.—The Bromuretted Vapour.—Acute Inflammation of the Tympanum 82—98

CHAPTER VIII.

DISEASES OF THE INTERNAL EAR.

Inflammation of the Internal Ear.—The Auditory Nerve.—Facial Paralysis.—Dr. Todd on Paralysis of the Portio Dura.—Cases of Facial Paralysis with Deafness. Aneurism of the Ear.—Disease of the Brain.—Non-inflammatory Disease of the Ear.—Treatment Page 99—106

CHAPTER IX.

MEDICAL ELECTRICITY.

Neglect of Electro Therapeutics.—Electricity not a “Specific.”—Application in Disease. “New Cures.”—Apparatus to be Employed.—Author’s Improvements in Magneto Electric Battery.—Application to Internal Organs.—Power of Current obtained.—Control over Current.—Author’s Instruments for Internal Organs.—Acute Inflammation of External and Middle Ear.—Throat.—Nose.—Condition of Membrana Tympani.—Loss of Muscular Power.—Deficiency of Nerve supply.—Neuralgia of Ear.—Nerve Pain, Treatment, Results obtained by Electricity.—Method adopted.—Cases.—Perseverance required.—Diseases in which Beneficial.—Medical Opinions.—Electro-puncture.—Conclusion.

107—119



ON DEAFNESS.

INTRODUCTION.

THERE is no malady to which humanity is subject, which deserves more universal commiseration than Deafness, kindred only to that which is elicited by the deprivation of sight. Surely, there is little to be surprised at in this, when we count the innumerable pleasures of life from which those are debarred who are deficient in the senses to which we have alluded. Shut out by the loss of one organ, from the entire world of sweet sounds, from the delights of music, from the consolations of sympathising voices, from the cheering gratulations of friends; and by the loss of the other, debarred from the enjoyment of all the varied scenes of nature and art, from the wonders science has revealed of the remote worlds that inhabit the immensity of space, or the minute denizens of a drop of water, and the microscopic marvels of a grain of dust; yet it is no less strange than true, that it is but of very late years that surgical skill has been concentrated upon the train of diseases which give rise to such deplorable conditions, with a view to their amelioration. This neglect is, however, fast passing away; medical men of high repute in this country and

on the continent are bringing such a concentration of study and talent to bear upon these subjects, that many obscure diseases of the eye and ear, hitherto considered intractable, now yield to the skill displayed in their treatment ; and, in the increasing development of medical science, we may hope for still more favourable results.

That the ear is not more thoroughly understood, is a disgrace to our schools of medicine, hospitals, and examining boards. By close investigation and observation diseases of this organ may be as well known as those occurring in other parts of the body. Why should not any surgeon be as capable of treating inflammation of the meatus auditorius externus, as a similar abnormal state of the urethra?—strictures, otorrhœa, morbid growths, and so forth, by the same rule. And why, again, should not the various diseases in the Eustachian passages and tympanum be diagnosed as correctly as a corresponding series of affections occurring in the bladder, stomach, or any other internal organ? Again, why should not diseases of the internal ear, the auditory nerve, and the part of the brain in the course of the auditory nerve, also the portion of the brain which is the seat of the special sense of hearing, receive the same attention with diseases of the brain generally? These questions scarcely require any explanation, for it must be obvious to every person who possesses common sense and chooses to consider the subject for one moment, that the palpable shortcomings in this respect must originate in the neglect of aural practice which prevails to an alarming extent in our schools of medicine and public hospitals, and which has been blindly tolerated by our several examining boards ; a circumstance which has consequently given rise to the abandonment of aural surgery to Charlatans, who in many instances, which must be familiar to all of us, have cruelly taken advantage of this state of things to aggrandise themselves pecuniarily,

whilst at the same time they have irretrievably ruined the last chance of sufferers, whose cases under proper treatment might not have been altogether hopeless. One method has suggested itself to us of rendering empiricism less successful, which we have endeavoured to carry out in the following pages ; namely, the diffusion of information on the structure and diseases of the organs of hearing. The day has gone by for shrouding the scientific in the supernatural, and making the "medicine man" a "dealer in mystery." As alchemy gave way to chemistry, and those phenomena which in the first instance were supposed to be connected with the hidden spirits of the unseen world, came in later days to be recognised as a science based on immutable laws, so the practice of medicine, which has long been clouded in a halo of mystery, and rendered unintelligible by an array of hard technicalities, is struggling to render itself appreciated as a science, subject to certain fixed rules of nature, and capable of demonstration to the popular intellect. There need be no fear, as some anticipate, that the spread of medical knowledge will set men perilously dabbling in medicine ; but it will rather serve to give them far greater reliance upon their medical attendant, since they will more readily appreciate the skill with which he applies his remedies.

CHAPTER I.

SOUND : ITS TRANSMISSION, VELOCITY, INTENSITY.—THE EAR AS AN APPARATUS FOR THE TRANSMISSION OF EXTERNAL VIBRATIONS TO THE BRAIN.

THERE is an old story of a sentinel at Windsor, who once on a time saved his life by declaring that St. Paul's clock had struck thirteen times at midnight instead of twelve, a fact which he is said to have still more energetically asserted from the circumstance of his having laid his ear to the ground and counted the distinct vibrations. This story is one with which almost every one has in some form or other made acquaintance. There is nothing very improbable in it, and it serves as a good illustration of the superiority of a solid medium, such as the earth itself, in contradistinction to the atmosphere, for the transmission of sound.

It is an acknowledged principle, that sound results from the disturbance of equilibrium in certain elastic bodies, and which is diffused equally around the point from whence it proceeds, becoming fainter and fainter as it recedes into distance. A very common-place, but yet excellent, illustration of the mode in which this disturbance takes place may be traced in a dense medium, water. A stone cast into a pond will cause a series of circles around the centre of disturbance, which gradually expand, and give way to others that succeed them, and thus the expansion and succession are kept up, until the remoter circles, becoming fainter as they recede, are ultimately too fine for us to trace them. Thus it is with sound : the further we are removed from the disturbing cause the weaker are its



impressions. We might represent this process by a series of lines, radiating from a central point, which diverge as they recede. At the distance of one inch from the centre a straight line of one inch in length would intersect a far greater number of these radiating lines than at a distance of two inches, and the latter a greater number than at three inches distance, the number diminishing as we move from the centre.

If, instead of a straight line, we suppose a funnel-shaped vessel to occupy its place, with its mouth turned towards the radiating point, we shall collect a number of these rays of sound, if the term may be so used, and not only prevent their further divergence, but also cause them to be concentrated by the sides of the funnel, until they meet at the lower opening, and are propelled down the tube.

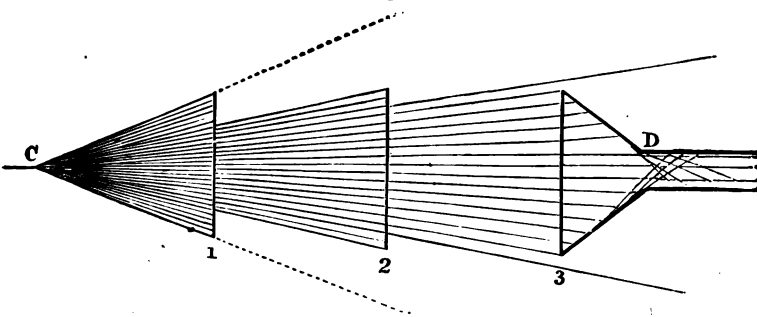
Fig 1.

The nearer this operation is performed to the centre, whence the sound proceeds, the larger will be the number of rays which will thus become collected and converged. After meeting again at the orifice of the tube, down which they proceed, their divergence will be prevented by the sides of the tube. Thus speaking tubes in large buildings are used to convey messages from one room to another, since the walls

of the tubes prevent the dispersion of the sound. Upon such principles is the external apparatus of the ear constructed. There is first provided a cartilaginous expansion to collect the rays of sound, and a tube or canal through which they are propelled.

But not only is the intensity of sound diminished by distance, but it is also considerably affected by the medium through which the undulations proceed. Bodies which are good conductors increase the intensity of the sound : hence we may conclude, that in the organs of hearing we shall find to a very large extent an application of these laws ; that we shall meet with certain arrangements analogous to the mechanical ones we have used for the purpose of illustration ; and that we shall discover therein the best of all possible apparatus for the transmission of external vibrations to the brain. If it has been shown that in the adaptation of the human eye to all the functions of vision, and of the human hand to all the varied conditions in which it is called upon to act, evidence of the designing skill, the power and wisdom of a great supreme Intelligence may be successfully traced, it can be equally demonstrated that the human ear, in its complicated yet harmonious construction, affords a parallel example and as conclusive testimony.

That we may comprehend this apparatus and these arrangements, it will be necessary in the first place to examine the anatomy and structure of the parts, and to trace their operation in producing the results for which they have been designed.

CHAPTER II.

ANATOMY OF THE EAR.

THE AURICLE IN MAN, IN ANIMALS.—ITS ADAPTATION FOR COLLECTING SOUNDS.—ITS MUSCLES.—THE EXTERNAL AUDITORY PASSAGE : INTRODUCTION OF FOREIGN BODIES.—THE TYMPANUM.—THE MASTOID CELLS.—THE EUSTACHIAN TUBE.—THE MEMBRANA TYMPANI.—OSSICULA AUDITUS.—THE VESTIBULE.—THE SEMICIRCULAR CANALS.—THE COCHLEA.—THE AUDITORY NERVE.

OUR description of the structure of the ear, will be but a general one, touching only upon the most important points.

For convenience of description, this organ has been divided into three sections, called, respectively, the external, the middle, and the internal ear.

First, the external ear. It is this portion with which most persons are best acquainted, since, as its name implies, it is that which has an external position. It consists of an outer cartilaginous expansion, answering to the funnel to which reference has been made, which collects from the air the undulations, or rays of sound, for transmission to the brain. In some of the inferior animals, this is largely developed, as in the elongated appendages to the head of that much abused animal, the domestic ass. In the elephant, also, this portion is very large and pendent. In the human subject it is not of disproportionate size, but is admirably adapted for the functions which it has to perform, its numerous depressions all leading to one point, the opening of the auditory canal.

If water, or any other liquid, has to be poured into a

narrow mouthed vessel, we find from experience that the best medium is that of a funnel, into the wide opening of which we pour the fluid without fear of losing any in the process. The form of this utensil tapering downwards to the opening of the tube, which we insert into our narrow-mouthed bottle, is analogous to that we have referred to in the ear, the liquid passing downwards and entering at the narrow opening in a manner corresponding to that in which the vibrations are collected by the funnel or *pinna* of the ear, and conveyed into the canal. A similar purpose is answered by those instruments known as ear-trumpets, which, at their wide openings, collect the undulations and transmit them into the auditory canal ; they are therefore only artificial sound funnels and are useful only to that extent. This cartilaginous funnel has a regular set of muscles connected with it, the functions of which are to place the pinna in the most favourable position for receiving the impressions of sound, as is evidenced by the rapid movements of this part in many of the lower animals in which these muscles are more highly developed than in man. In the lion, tiger, dog, cat, hare, and rabbit, the erection and depression of the ear, as this portion is in ordinary language more commonly called, is very evident. Dependent for safety upon the readiness with which sounds are detected, or for their prey in the aptitude for discriminating its slightest motion, these animals possess great facilities for erecting, depressing, or otherwise moving the external cartilage of the ear. In man this is not so evident, but to a certain extent it exists.*

* We have dissected the external ear, more especially the auricle, extensively in the lower classes of animals with the view of determining the power of these muscles in them in comparison with the human species. We find man possesses a limited power of raising and depressing the various parts of the auricle, or external ear, namely, the helix, antihelix, tragus, antitragus, and lobe, though the action is quite imperceptible to ourselves, whereas many animals can bring



The second portion of the external ear, is the canal or passage leading from the base of the funnel inwards to the membrane of the tympanum ; it is about an inch in length, tending downwards at its inner extremity, and smaller in diameter at about the middle of its length than at either end.

The lining of this canal is of delicate texture, generally possessed of a series of rigid hairs near the external orifice, and well supplied with ceruminous glands which secrete the wax of the ear. Both the secretory glands and hairs have functions to perform, which, though apparently insignificant, are not really so. The former, to obviate too great dryness and harshness in the integument ; the latter, to prevent dust, and other light substances floating in the air, from entering the passage and causing irritation. Unless we proceed upon the hypothesis that these *protecting* hairs, *as we regard them*, are merely accidental, and therefore really malformations or monstrosities, how can we account for the pertinacity with which all kinds of substances, such as plugs of cotton-wool, gutta-percha, onions, figs, and other nostrums, are introduced into this sensitive passage (from which *nature* has done its best to exclude foreign bodies), as if it were intended that this should be a receptacle for every variety of refuse matter, or as a means of ascertaining by actual experiment the extent to which irritation may be carried without producing the most fatal results. And this too is done with a total disregard to the condition of the membrana tympani—whether it is perforated or not, whether it is sound and perfect, or almost entirely obliterated. It seems to enter at no time into the calculation whether, or not, these foreign bodies are liable to insinuate themselves into the cavity of the middle ear, a

the auricle into any position according to their will. This is *one* reason why their hearing is so much more acute than man's. When describing the internal ear, we shall be able to give another reason for this physiological fact.

locality in which their presence would prove most disastrous. Having described the external ear, and alluded to its functions of collecting the sounds and vibrations, and conveying them to the tympanic membrane of the ear, the medium of communication between the external and middle ear, let us proceed to the latter part, which is a bony cavity of about half an inch in diameter either way, and situated in the petrous portion of the temporal bone; it is therefore all that portion situated immediately between the internal and external ear, properly called the tympanum, or drum, with its appendages. It is a conical-shaped cavity, somewhat irregular in its figure, possessing as it were a floor, a roof, an anterior and posterior wall, and an internal and external extremity. The posterior wall has several eminences, or bony projections upon it, also a number of openings for the passage of blood-vessels and nerves; the most important openings on this wall are those of the mastoid cells, which are numerous, and take their name from the fact that they occupy the whole of the interior part of the mastoid process, and greater part of the petrous portion of the temporal bone. Their functions are variously stated, but they seem to have none other than that of merely increasing the intensity of sound while passing through the tympanum.

In the anterior wall are also several openings, the most important being the Eustachian tube, or air passage, which passes from the back part of the throat, or pharynx, into the tympanum, and is for the purpose of admitting a free current of air into that cavity. It measures a little more than an inch and a half in length, varying in different subjects. It is lined throughout with a continuation of the mucous membrane which lines the pharynx, tympanic cavity, and mastoid cells, and which also form the internal layer of the membrana tympani, fenestra ovalis, and fenestra rotunda. The tube has



a large trumpet-shaped mouth in the throat, and becomes much narrower as it proceeds into the cavity of the tympanum, and as it is composed of one half cartilage and one half bone, it may be said in some respects to be analogous to the external ear. We shall be more explicit upon the physiology of this passage in another part of our work.

The external extremity of the tympanum communicates with the *meatus auditorius externus*, from which it is separated by the *membrana tympani*, this beautiful little membrane forming, as it were, a distinct partition between the two. It is semi-transparent, and of an oval shape, situated in a groove around the circumference of the extremity of the meatus, and is placed obliquely, its upper surface looking outwards and downwards, while its lower surface looks somewhat inwards. Towards the meatus it is concave; and convex in the tympanum, in which direction it is drawn by its attachment to the handle of the malleus. It consists of three distinct layers; the external, being the skin, which lines the auditory passage, the internal, being the mucous membrane, to which we have recently referred as lining the tympanum and other parts of the middle ear, and the middle, which consists of two distinct sets of muscular fibre, namely, a circular set in the centre, and a radiating set proceeding from the circular set to the circumference; these muscular fibres are somewhat analogous to a similar arrangement met with in the iris, which forms part of the second tunic of the eye-ball. We have taken great pains in examining the membrane microscopically, to satisfy ourselves upon the action of these muscular fibres, and think we are in a position to show that they possess much greater and more important functions than have been assigned to them by physiologists, to which functions we shall allude in another part of this work.

The inner extremity of the cavity communicates with the

internal ear,—firstly, through the medium of the fenestra ovalis, which communicates with the vestibule, being separated from that cavity by a membrane corresponding to that of the membrana tympani, just opposite which it is placed; immediately below this again is the fenestra rotunda, which communicates with the cochlea. Upon all the various walls of the tympanum may be found other peculiarities of structure, with which, however, we will not occupy further time, as those which have been mentioned are the most important, in performing the delicate functions of the organ. Passing through the centre of the tympanum is a chain of three small bones, anatomically termed *ossicula auditus*; these bones are called the malleus, incus, and stapes, from their respective fanciful resemblance in shape to a miniature hammer, anvil, and stirrup, the point of junction between the incus and stapes being occupied by a small portion of bone called the os orbiculare, which, during foetal existence, constitutes a separate bone; they form a connecting link between the membrana tympani and the membrane of the fenestra ovalis in the following order:—first, the malleus attached to the membrana tympani and articulated to the second bone, the incus, which hangs, as it were, suspended in the cavity, having a ligament attached to it, which connects it by its short process to the margin of the opening of the mastoid cells, its long process tapering gradually downwards, to be connected, through the medium of the os orbiculare with the head of the stapes; the last-named bone is in immediate connection, by its base or foot, with the membrane of the fenestra ovalis.

Before going on to describe the attachment of the muscles to these bones, we wish particularly to direct attention to the manner in which they are connected with each membrane, and a great physiological point will be gained when we

consider their distinct functions. It will be seen that the handle of the malleus is situated between the muscular and mucous layers of the membrana tympani, while the foot of the stapes is exactly in the same relation to the membrane of the fenestra ovalis, being placed between the mucous layer of the tympanum and that which lines the cavity of the vestibule. The muscles of the tympanum are the tensor and laxator tympani, laxator tympani minor, and stapedius. Some writers have attempted to prove they are ligaments, but from careful microscopic observation we are prepared to state that they possess all the characteristics of muscular fibres, and therefore consider them distinct muscles.

The tensor tympani arises from the spinous process of the sphenoid, from the petrous portion of the temporal bone, and from the Eustachian tube, its functions being to draw the malleus inwards and keep the membrana tympani in a tense state. The laxator tympani arises from the spinous process of the sphenoid bone, and is inserted into the neck of the malleus, and acts in opposition to the other muscle, by relaxing the membrane. The laxator tympani minor arises from the upper margin of the meatus, and is inserted into the handle of the malleus; its function appears to be to regulate the other two muscles, that is to say, to prevent either of them acting too forcibly upon the membrane. Passing to the other side of the cavity is the stapedius muscle, arising within the pyramid and inserted into the neck of the stapes; the action of this muscle is to raise the stapes, and press its base against the membrane of the fenestra ovalis.

The part which now remains for description is the internal ear, the most complicated and extraordinary portion of the entire aural structure. From its complexity it has received the name of *labyrinth*. The cavities of this portion are situated in the hardest part of the bony structure of the

head. The inner ear may be said to consist of three parts, viz., the vestibule, or triangular entrance hall into which the other parts have openings, and which is separated from the middle ear by a membranous curtain, the semicircular canals, and the cochlea. The semicircular canals, so called from their shape, are three passages communicating with the vestibule. The cochlea is a spiral canal passing round a central column in the manner of a winding staircase, or a more apt illustration might be found in the shell of a volute, where the internal chamber passes spirally around the columella; a section, therefore, of such a shell as the common whelk would resemble a section of the cochlea of the human ear.

The labyrinth is lined throughout with a membrane of a fibro-serous nature (which is analogous to the dura mater), its fibrous layer forming the periosteum for the bony cavity, while its serous layer performs the office of secreting the limpid fluid termed the aqua labyrinthi. The membrane itself is held in connection with the bony cavity by the nerve filaments which pass through the small openings. It closes the fenestra ovalis, and fenestra rotunda internally, being assisted externally by the membrane lining the tympanum with an intermediate structure. It will be seen that the membrane of the fenestra ovalis and rotunda is formed of three distinct layers, similar to those of the membrana tympani, only differing from them in their character.

The auditory nerve (*portio mollis*) is generally described as part of the seventh pair of cerebral nerves, according to Willis, but as its functions are entirely distinct from those of the *portio dura*, or facial nerve, which is also classed under the head of the seventh pair of cerebral nerves, we consider it best to adopt the more simple and correct system of Sœmmerring, and to speak of the auditory nerve as the eighth pair. It arises with the facial in the *lineæ transversæ*



of the interior wall or floor of the fourth ventricle, and winds round the corpus restiforme, from which it receives fibres to the posterior border of the crus cerebelli. It then passes forward on the crus cerebelli, and enters the meatus auditorius internus, receiving several filaments from the facial nerve in that passage; at the end of the meatus it divides into two branches, namely, vestibular and cochlear; each of these are again subdivided into innumerable filaments which are distributed to every portion of the internal ear. It is quite an undecided point whether the vestibular or cochlear nerve may be regarded as the true nerve of hearing but the situation of the former is certainly the most favourable for communication with the brain.

Fig. 2.

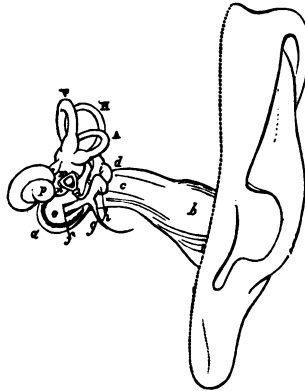

SHOWING THE EXTERNAL, MIDDLE, AND INTERNAL EAR.

- b, c.* Meatus auditorius externus.
- e.* Membrana tympani, with a view of its attachment to the handle of the malleus.
- f, g, h.* Malleus: its head, neck, and handle, with its articulation to the incus.
- i, k* Incus, with its long and short process.
- m.* Stapes, with its attachment to the membrane of the fenestra ovalis.
- v, h, a, m, n, p.* Labyrinth. *n, p.* Concha. *m.* Vestibulum. *v, h, a.* The semicircular canals.

The Ossicula Auditus.

Fig. 3.

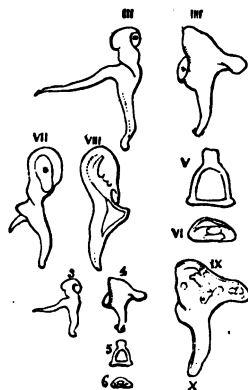

3, 4, 5, 6. Representing the ossicula auditus in the natural size.

3. The malleus.

4. The incus.

5. The stapes.

6. The orbiculare.

III. IIII. V. VI. VII. VIII. IX. The ossicula auditus, magnified twice the natural size. VII. VIII. IX. showing the articular surfaces.

CHAPTER III.

PHYSIOLOGY OF THE EAR.

THE FUNCTIONS OF THE AURICLE : OF THE CONCHA.—DR CARPENTER ON THE CONCHA.—THE DEVELOPMENT OF MUSCLES.—FUNCTIONS OF THE AUDITORY CANAL.—FUNCTIONS OF THE TYMPANUM.—AIR OF THE TYMPANUM.—ITS ACTION UPON THE MEMBRANA TYMPANI : UPON THE CHAIN OF BONES : UPON THE FENESTRA OVALIS.—FLUID OF LABYRINTH.—FILAMENTS OF THE AUDITORY NERVE.—FUNCTIONS OF THE COCHLEA.—FUNCTIONS OF THE SEMICIRCULAR CANALS.—M. FLOURENS ON SEMICIRCULAR CANALS.—THE AUDITORY NERVE.—EXPERIMENTS ON DOGS.

In our former chapter we confined ourselves to a description of the anatomy, or position of the parts, with very few physiological observations. We will now endeavour to show the manner in which the undulations are taken up by the first portion of the ear, and conveyed, through the medium of the different parts of the organ itself, to that portion of the brain which is the seat of the sense of hearing.

In the first instance, as we before described, the auricle is beautifully curved, forming a number of eminences and depressions, which collect and direct the impression into one particular channel, so as to concentrate and bring them within the scope of the concha.*

We may here observe that the better the auricle is marked

* "The cartilage of the external ear may propagate sonorous vibrations in two ways, by reflection, and by conduction. In reflection, the concha is the most important part, since it directs the reflected undulations towards the tragus, whence they are thrown into the auditory passage."—*Dr. Carpenter's Principles of Human Physiology*, p. 726.

in this respect, and the more strongly developed the muscles which are attached to it, the greater power will it possess in performing this function. The concha in shape somewhat resembles the aperture of an ordinary univalve shell; its opening is continuous with that of the external meatus, so that it will be seen that when the sound is received by the first portion of the concha, it takes a sweep around the cavity, being greatly increased in intensity on its course, till it is brought within the range of the first portion of the meatus. The functions of the auditory canal are then brought into operation; this passage being curved upon itself, is much better calculated to conduct the impression to the membrana tympani than if it were perfectly straight, and the fact that it is kept constantly lubricated by the ceruminous glands render it much more so. Having now conducted the impression to the membrana tympani, it will be necessary to consider the entire function of the tympanic cavity and its appendages; and also if the auricular chain of bones is or is not the medium by which the undulations are conveyed from the external to the internal ear.

It has long been supposed that a continuous current of air passes through the Eustachian passage into the cavity of the tympanum, and that should any circumstance arise, from any cause whatever, to obstruct this free current, dulness of hearing or deafness would result. Mr Harvey has proved this fact in his excellent work on "Diseases of the Throat." Itard, Deleau, Kramer, and Wilde also agree on this point. This current of air acts upon the internal surface of the membrana tympani, while that passing down the external meatus acts upon its outer surface, and these combined actions keep up a constant vibration of the membrana tympani, together with the action of the radiating and circular sets of fibres previously described as existing in this membrane;

this vibratory motion of the membrane sets up a waving motion of the chain of bones in the cavity, which causes a corresponding vibratory action of the membrane of the fenestra ovalis, and there is no doubt that it is the motion of this latter membrane which excites very fine oscillatory movements of the fluid in the labyrinth, and that this fluid must be in a perfect state to receive impressions before the functions of the internal ear can be brought into play at all. Scemmerring, Cotunnius, and Scarpa were of opinion that if this fluid were lost the filaments of the auditory nerve would become entirely useless, and deafness be complete. We think we are in a position to show, both by experiments and well observed cases, that although its absence would cause great indistinctness of hearing yet some degree of this faculty would still exist.

Mr. Toynebee has endeavoured to prove that the undulations are conveyed from the cavity of the tympanum to the internal ear, through the medium of the fenestra rotunda, but he so completely contradicts himself, that no reliance can be placed upon his observations, and in his work on "The Disease of the Ear," he at various pages gives totally different views on the subject; this may be very convenient when wishing to frame a theory for artificial membranes, but is palpably erroneous when it comes under the observation of experienced surgeons. We will give two extracts so that our readers may form their own judgment upon the matter.

"There is, it seems to me, no doubt but that one of the functions of the membrana tympani is to confine the sonorous undulations to the tympanic cavity, in order that they may be concentrated on the membrana fenestræ rotundæ. Indeed, it is probable that the vibrations only partially pass through the chain of bones to the vestibule,

and that the air in the tympanic cavity is one medium of communication with the labyrinth. If the means of communication with the labyrinth be the air in the tympanic cavity, it is palpable that an aperture in the *membrana tympani* is likely to diminish the power of hearing, by permitting the vibrations to escape from that cavity into the meatus, and so prevent their concentration upon the *membrana fenestræ rotundæ*." (Page 160.)

"In cases of general ulceration of the mucous membrane of the tympanum which fortunately seldom occurs, the incus is commonly discharged, and sometimes the malleus also, but even in these cases, if the attachment of the *stapes* to circumference of the *fenestræ ovalis* remains uninjured, the power of hearing may be greatly improved; *should the stapes, however, be removed, total and irremediable deafness ensues.*" (Page 166.)

It will be seen from the first of these paragraphs that Mr. Toynbee distinctly says that the vibrations are concentrated upon the *membrana fenestra rotunda*, and we presume from thence to the internal ear, and that they only pass through the chain of bones. Supposing this statement to be correct, the *membrana fenestra ovalis* can be of little use for the transmission of sound, and consequently the detachment of the *stapes* from that membrane can cause very little, if any, diminution of hearing, while in his second paragraph he deliberately states that should the *stapes* be removed from the membrane of the *fenestra ovalis* "total and irremediable deafness ensues," a remark which can have no other meaning than that all the sonorous undulations are conveyed through the medium of the *fenestra ovalis*.

The tympanic chain of bones, however, is not the only means of communication with the internal ear, the bones of

the head evidently forming a medium, more especially the mastoid portion of the temporal bone, and this is how we account for the circumstance that the mastoid cells possess the power of increasing the intensity of sound while passing through these bones, for it is evident they can have little or no power of acting upon the small chain of bones contained within the tympanum. We will now proceed to account for the functions of the separate parts of this complicated piece of anatomy. Supposing the old writers to be correct, and that the fluid of the labyrinth receives the impressions from the membrane of the fenestra ovalis, the cochlea appears to be the next portion brought into operation, and has the power of increasing or decreasing the sound according to the capacity of the filaments of the auditory nerve. In the first place, if the undulations are defective, the cochlea has the power of increasing their intensity, while, on the other hand, if too great, of diminishing them, and those undulations which cannot be taken up by the filaments of the auditory nerve pass back into the cavity of the tympanum, through the fenestra rotunda, so that it will be seen that instead of the vibrations passing through this opening from the tympanum into the internal ear, they pass through it from the internal ear back into the tympanum. The cochlea is therefore for the purpose of modulating the intensity of sound, and allowing the escape of the vibrations when too numerous to be taken up by the filaments of the auditory nerve.* Writers have assumed different functions to the semicircular canals, some supposing that they have the power of estimating the intensity of sound, others the quality, others again of increasing it, while some

* M. Dugès supports the view that by the cochlea we are enabled to estimate the intensity of sounds from the fact that the development of the cochlea follows that of the compass of the voice, the cochlea being greatest in the mammalia, diminishing in birds, and in reptiles disappearing almost entirely.

assign to them all those functions combined. The most generally received opinion, however, is that they indicate the direction of the sound. M. Flourens coincides in this opinion, as will be perceived from the following extract.

“From section of the portion of the auditory nerve proceeding to the semi-circular canals. Section of the horizontal semi-circular canal in pigeons, on both sides causes a rapid jerking horizontal movement of the head from side to side; and a tendency to turn to one side, which manifests itself whenever the animal attempts to walk forwards. Section of a vertical canal, whether the superior or inferior of both sides is followed by violent vertical movement of the head. And section of the horizontal and vertical canals at the same time causes horizontal and vertical movements. In rabbits section of the horizontal canal is followed by similar movements. Section of the anterior vertical canal causes the animal to make continued forward ‘somersets,’ whilst section of the posterior vertical canal occasions backward ‘somersets.’

“These curious results are supposed by M. Flourens to indicate that the nerve supplying the semi-circular canals, does not minister to the sense of hearing, but to the direction of the movements of the animal; but they are fully explained upon the supposition that the normal function of the semi-circular canals is to indicate to the animal the direction of sounds, and that its movements are partly determined by these, so that a destruction of one or other of them will produce an irregularity of movement.”—*Carpenter's Physiology*, page 506.

The next portion for description is the auditory nerve; its minute anatomy and physiology are so well authenticated that it will be sufficient for us to state here that it is the medium by which the undulations are conveyed from the

labyrinth to the brain. If this nerve be healthy, with nothing to compress it, or interfere with its functions, we are of opinion that hearing may still remain, though considerably weakened, even if all the parts described are removed.

The following experiments we think substantiate the above statement:—On June 4th, 1860, we took away a portion of the membrana tympani of a dog on both sides, being careful not to interfere with the chain of bones, but this caused little perceptible difference in the hearing; on the 13th we entirely destroyed the membrana tympani, causing a considerable decrease in the faculty; on the 20th we took away the entire chain of bones, after which the hearing became much impaired: not being satisfied with this, we tried a similar experiment upon a second dog, with the same negative result on removal of the membrana tympani; but on bringing away the chain of bones, the membrana fenestra ovalis was also accidentally removed with the stapes, and the dog became quite deaf; we concluded that the fluid in the vestibule had been lost, and so accounted for the loss of hearing; but on examining the ears we found a quantity of coagulated blood in the cavity of the tympanum, doubtless caused by the injury occasioned by the removal of the bones; after removing this the hearing returned, though evidently much impaired.

From these experiments it appears to us, first, that the removal of the membrana tympani causes slight decrease in the hearing power; secondly, that the removal of the bones increases this difficulty; and thirdly, that the removal of the membrana fenestra ovalis *adds* still *further* to the difficulty; and it is quite evident that when the fenestra ovalis is destroyed some portion at least of the fluid in the vestibule must be lost; proving, therefore, that if the filaments of the auditory nerve are good, and the nerve sound on its course,

the hearing will *not* be so defective from loss of these parts as many writers would make it to appear. We have tried similar experiments with like results on various animals both before and since those which we have detailed. The most important point is that the passages to the auditory nerve are clear, which is seldom the case after disease has been set up in any part of the organ.*

From this cursory description of the salient points in the anatomy and physiology of the organ of hearing, it will have at least been made evident that we have composing it a most compact and delicate apparatus; eminently calculated for the functions it has to perform, and like all other delicate machinery excessively liable to derangement.

* See perforation of membrana tympani, and loss of chain of bones with supposed loss of fluid in the vestibule, p. 102.

CHAPTER IV.

DISEASES OF THE AURICLE AND EXTERNAL AUDITORY PASSAGE.

ACUTE ERYSIPELAS OF THE AURICLE.—SYMPTOMS AND TERMINATION ; CASES.—CUTANEOUS DISEASE.—ECZEMA.—HERPES.—SCROFULOUS ULCERS.—ENCYSTED TUMOURS.—HYPERTROPHY : CASE.—FROST BITE.—WOUNDS AND INJURIES.—CASES.—ABSCESSSES.—THE SPECULUM. AUTHOR'S SPECULUM.—EXAMINATION OF THE AUDITORY PASSAGE.—INFLAMMATION OF THE EXTERNAL AUDITORY PASSAGE: ACUTE AND CHRONIC: TREATMENT.—TINNITUS AURIUM : CASES.—ABSCESSSES : ACUTE AND CHRONIC.—CASES.—ULCERS : THEIR CONSEQUENCES IF NEGLECTED : TREATMENT.—SYPHILITIC ULCERS.

THE skin of the auricle is very sensitive, and liable to many forms of disease, principally inflammatory, which may be brought on by any irritating cause that would produce inflammation in other parts of the body.

Inflammation of the external ear, called by many writers acute erysipelas of the auricle:—Symptoms ; redness of a vivid scarlet tint ; swelling, stinging, burning pain, head-ache, nausea, and fever. The swelling of the parts is often so great that the form of the meatus is almost obliterated. It terminates occasionally in abscesses, leading to unhealthy suppuration of the cellular tissue. It often assumes a lingering or chronic form, leaving the auricle thickened, with the skin of a dark buff colour, and the meatus considerably lessened in calibre.

CASE.—Mrs. J., aged 40, consulted us in August, 1859 ; she complained of a severe smarting and burning pain in the right auricle, with considerable deafness. The auricle

was much swollen and of a deep red colour, and very painful to the touch. She complained of head-ache and general debility. We had the advantage of seeing this case in the first stage. An emetic of ipecacuanha wine was ordered, followed by pil. hyd. gr. v., ext. rhei, ʒss. every four hours, and the diseased part painted with a solution of nitrate of silver. Under this treatment, the pain and tenderness diminished after four days, and the swelling was quite abated. We now prescribed quinine and iron, together with a liberal diet, and in a few weeks the patient's health and hearing were quite restored.

M. A. S., a female aged 56, has been subject to erysipelas of the face and head for ten years; for the last three it has, however, only attacked the ears. This patient was of a weak and irritable constitution, with a sallow, haggard countenance, her tongue was furred, and she suffered from flatulency after eating; the skin was dry and harsh, and the bowels costive; her hearing had been getting gradually worse since the disorder attacked the ears. The auricle was of a purple hue, and very tender and painful, with small pustules scattered over it, which were filled with a whitish matter. She was ordered calomel, gr. ij., opium, gr. ʒ, at bed time. A draught of quinine and diluted sulphuric acid in the day time, with good nourishing diet; the local treatment consisted of a weak wash of sulphate of zinc; under this course, steadfastly followed for three weeks (omitting calomel occasionally), her general health improved and the auricle assumed a natural appearance and colour. She was now ordered to take a warm bath every second morning, afterwards to use Child's flesh brush to the whole surface of the body, and to continue the tonic mixture. She pursued this treatment, sometimes varied, for three months, after which her health became established and hearing good.

C. P., aged 30, a governess, had been subject to eruption on one side of the face and neck for nine years, and lost her last situation in consequence of its disagreeable appearance. She had been treated for scurvy by a gentleman who told her the complaint would never be cured, and during the last two years the eruption had spread over the auricle. She was of a pale, sallow complexion, much debilitated, and greatly depressed in mind and body in consequence of losing her situation, together with the idea that she laboured under an incurable disease. The skin in this case presented a yellowish appearance, with an unusual degree of serous effusion; there was scarcely any sensation beyond a slight tingling and itching, which increased at night and when the patient became warm. She was of a costive habit, her menses were irregular, and she evinced considerable dislike to food; the pulse was weak. Hearing power slightly diminished. The prognosis in this case was altogether very unfavourable. She had been kept on very low diet, and forbidden to take wine or malt liquors.

We ordered a warm tonic purgative of aloes, quinine, and rhubarb with nutritious diet, and gentle exercise, with the use of a warm bath three times a week; in four weeks the menses appeared for the first time in seven months, and in two more she stated that she felt herself much stronger. We now determined to bring her system gently under the influence of mercury, though she told us that she never could take it, as it always made her very ill; the sixteenth part of a grain of bichloride of mercury, with bark, was prescribed to be taken three times a day, one hour after meals.

We may here mention that the lady was not aware we were giving her mercury, for so firmly was she convinced that to take it would cause a train of unpleasant symptoms that we believed that from the force of imagination such would have

been the case, and therefore deemed it allowable to maintain a certain reserve in the matter. The preparation agreed with her well, and occasioned no disagreeable sensation, although, with short intervals of cessation, we kept up its administration for three months. All her bad symptoms disappeared, she gained flesh, her countenance and complexion became bright and clear, the skin free from eruption, and the menses and bowels regular. She went to a situation in the country, and to the present time, nine months having elapsed since she was under our care, the disease has not reappeared, and her health has continued good.

The auricle is also liable to suffer from all the forms of cutaneous disease, the most common of which are eczema and herpes. Mr. Wilde describes eczema aurium as most frequent in females of middle and advanced life, but states that it also attacks children of from six to twelve years of age, and often coexists with scald head. Mr. Toynbee also describes it, almost in similar words, recommending the same treatment.

It is very true that it occurs most frequently in middle-aged women and young children, but we have also found it to exist in both sexes, and at every period of life.

Mr. Wilde recommends poultices, and afterwards, when the heat and swelling have subsided, a solution of the liquor plumbi diacetatis, in the proportion of a drachm to an ounce of water, applied with lint in such a manner as to envelope the auricle, the evaporation being prevented by covering the whole with oiled skin.

This local treatment, of which we can speak favourably from the results obtained in our own practice, rarely fails to lessen the irritation.

The constitutional treatment consists in saline purgatives, antimonials, and occasionally mercurials. Should the inflam-

mation extend to the auditory passage, more active treatment would be required, on account of the danger of the destruction of the soft parts, more especially of the membrana tympani, which, by becoming implicated, might transmit the disease to the cavity of the tympanum. In all these cases cleanliness cannot be too strongly enforced, When the disease extends to the auditory passage there will be great effusion and swelling of the membrane, and the sense of hearing will be greatly impaired; counter-irritation, and the application of a solution of nitrate of silver or sulphate of zinc will be beneficial, also gentle syringing of the auditory passage with tepid water. In children, especially, change of air, if in summer, to the sea-side, should be recommended.

In children of a scrofulous habit we often find small flat pustules about and behind the ears, with exudations of irritating matter, which dries into scabs; here cleanliness also must be attended to, and the general health improved; the application locally of zinc ointment would be useful.

Scrofulous ulcers of the auricle are generally the result of acute inflammation of that part in a scrofulous subject. They are characterised generally by a hardened base, ragged edges, redness and heat of the surrounding skin, and very severe pain. These ulcers spread with great rapidity, are liable to lead to suppuration and sloughing, and are difficult to heal, as they commonly occur in debilitated unhealthy subjects. The treatment must consist in a liberal diet, with good wine and malt liquor, the use of tonics and alteratives, with a local application of lint dipped in a solution of nitrate of silver, or touching the edges and base with a stick of the solid nitrate; if the pain be very severe opium may be administered.

Tumours beginning in the skin of the auricle in the form of hypertrophy of the dermis, and papillæ, as warts, condy-

Warts, or other warty growths, should be carefully guarded from irritation, and in no instance, if they are not troublesome, should they be meddled with; in many cases, by following this rule, these warty vegetations would rarely cause any ill consequences; while on the other hand if cut or irritated by caustic applications they are liable to return and ulcerate, and spread into all the neighbouring tissues; when ulceration has once commenced its course will not be stopped in all probability till a slow and painful death terminates this history of injudicious surgery. Should, however, the tumour begin of itself to be troublesome in spite of every precaution, instant excision affords the only chance we have of saving our patient's life. This disease, in its tendency to spread among adjacent structures, resembles cancer, from which affection it differs, however, in offering more hopes of cure by excision. Constitutional treatment must not be neglected; good diet, wine, iron, quinine, and iodine may all be tried and found useful.

Encysted tumours of the auricle containing oil-globules and epidermic scales, sometimes lead to suppuration and ulceration; if not very large they may be opened by a probe, and the contents let out, when they generally heal; or they may require to be extirpated by the knife. Such tumours should not be meddled with when the patient is out of health.

In hypertrophy of the auricle that part considerably increases in size, so as to fall in flaps upon the neck; it is generally soft and painless, and if inconvenient from its weight may be removed by the knife; the preparations of iodine and liquor potassæ may be taken internally, but rarely influence the growth.*

* Dr. Graves records an interesting case of fatty tumour of the auricle in his "Clinical Medicine."

CASE.—T. C., a young man about twenty-five years of age, presented himself at the National Ear Institution in September, 1859, with an enlargement of the right auricle; its growth had been very slow, commencing when he was about eighteen, but it had now become so very inconvenient and unsightly that he was anxious to have it removed. The tumour was soft and painless, feeling like a mass of fat; the patient was strong and healthy, and said he had never had a day's illness in his life; his hearing was perfectly good. We dissected out the tumour, the wound healed quickly, and the patient was well pleased to be relieved of the annoying appendage.

Frost bite of the auricle is very common in cold climates, though in our own it seldom comes under the notice of the surgeon. The treatment is the same as that for frost bite in any other part of the body, namely, to produce reaction, and restore the circulation and to avoid excessive reaction. The best remedy is to rub the part well with snow in a room without a fire; often no inconvenience follows, although the part feels cold for some time; if gangrene set in, stimulating poultices and ointment may be employed; acute atrophy of the auricle is sometimes the result. Three cases of frost bite came under our treatment in the winter of 1860, in which the above was carried out with success.

WOUNDS AND INJURIES OF THE AURICLE.

“According to Itard the auricle is of no use in hearing in man or animals, and he states that the loss of it is quite immaterial. Vering coincides in this opinion, supporting it by a communication from Dr. Steinmetz respecting a child a year and a half old, who had on the right side, instead of an auricle, three small elevations of thickened integuments, slightly connected together; and on the left a

single elevation of the same kind, which might be considered as the lobus, the meatus externus being, however, completely closed over by integument. In spite of all this the child heard perfectly well. Buchanan is directly opposed to Itard's view, and makes acute hearing so far dependent on the auricle, that he believes, from its form and angle of attachment to the temporal bone, as well as from the form and depth of the concha, sufficiently certain prognostic data may be acquired to allow of our determining on the curability or incurability of those cases of diminution of hearing in which all other symptoms are too obscure for this purpose."—*Kramer, on Diseases of the Ear.*

Mr. Toynbee imagines that he is placed in a position to decide this important question, but to what extent he is so may be judged from the fact that he only gives one isolated case in the support of his opinion,—“a sailor in whom the whole of the upper portion of the auricle was absent, and in whom the hearing power was equal in both ears.”

We are ourselves of opinion that the auricle plays a very important part in collecting the vibrations, and we think that a reference to our description of the physiology will go far towards establishing our opinion. It is true that nearly all the external ear may be taken away and the sense of hearing remain, but still a great diminution will be found on testing it, and the following cases seem to give stability to this theory.

CASE.—J. J. consulted us in the early part of 1859 for injury of the external ear. On examination we found the whole of the auricle bitten off on the left side. The man was a mechanic, and had been fighting with a Lancashire man, being himself a native of that county. They fought in what he called the up and down fashion; in which he explained that biting and kicking are allowable on the ground.

The consequence was that his opponent had bitten off the auricle, leaving merely the tragus, antitragus, and a clear passage into the meatus. We succeeded in healing the wound, after which we examined minutely the meatus auditorius, externus and membrana tympani of both ears, and found them in a perfectly healthy state (we may here mention that his hearing had always been very acute); the distance at which he could hear the tick of our watch on the uninjured side was forty inches, on the injured twenty-six inches, making a difference in his hearing power of fourteen inches. Now by an ordinary observer, without a test of this kind, the loss of hearing would never have been detected; since with one ear acute, and the other able to hear at twenty-six inches, the sense was still excellent, and he declared he heard as well as ever he had done in his life; nevertheless, by experiment he was proved to have lost a considerable degree of hearing power. We saw the man nine months after the accident and the hearing still remained the same, not having either increased or decreased on the injured side, proving, we think, beyond doubt that the diminution of hearing arose solely from loss of the auricle.

CASE.—T. D. consulted us for deafness in both ears in January, 1860. We found the upper portion of the auricle on the right side absent, a circumstance for which he accounted by saying a surgeon had cut it away in consequence of a tumour upon it. We found on examination that the meatus on both sides was completely plugged up with wax, on removing which with the syringe his hearing appeared apparently perfectly restored. The membrana tympani and neighbouring parts presented about the same appearance on each side, but on testing him with the watch we discovered a diminution of nine inches in the hearing power on the side where the auricle was defective.

THE SPECULUM

Before entering upon the consideration of the diseases and irregularities of the different structures of the auditory passage, we will make a few observations upon the speculum and the manner of using it. This instrument in some form or another has been known from the most remote period. The first ear speculum was a modification of that used in the examination of the vagina, and the improvements introduced in its form from time to time can be traced to improvements on the latter instrument; for it is a notable fact that whenever such were introduced, the idea was at once taken up by aural surgeons, and a new speculum sent forth: we do not intend to find fault with this, for if we can make a valuable alteration or modification, from whatever source it may be derived, both the scientific world and the public generally receive the benefit. It is not therefore merely the original inventor of an instrument to whom we are indebted, but also those who improve upon it, and adapt it to various uses. Fabrici de Hilden was the first to whom we can trace the use of the speculum in aural disease, the one he used being simply the forceps with two half-circular valves introduced, these valves being made to open and shut with the forceps, according to the will of the operator. Upon this principle have been made all the speculums in use up to a late period, every surgeon having his favourite shape; those of Itard, Deleau, and Kramer being most commonly used. It is now, however, thought that from the weight of the forceps, and no material amount of dilatation being required in the examination of the external meatus, that a mere tube made exceedingly light is all we require for that object; this being the speculum recommended by Harvey, Wilde, Toynbee, Bonnafoot, &c. Friquet, how-

ever, adheres to the forceps-speculum, and in some instances we ourselves prefer it, though, as a general rule, we use the simple tube. A speculum made of glass is preferable to any constructed of metal, both on account of cleanliness and lightness. Again in using caustics to the membrana tympani, in drops, it forms an admirable funnel. The advantage of using speculums made of glass will be apparent when we consider that, chemically speaking, there are few metals upon which caustics do not act more or less, a circumstance which must prove detrimental to the parts.

THE AUTHOR'S SPECULUM.

Fig. 4.

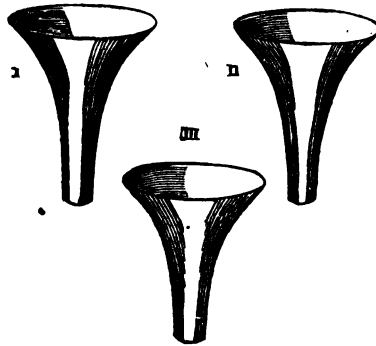

No. I. The smallest sized speculum.

No. II. The next size.

No. III. The third size, gradually increasing in size up to No. VI.

The surgeon should possess at least six of the tubes in sizes ; as there are many instances in which from contraction and other morbid conditions we are compelled to use an exceedingly small one for an adult, and again a large one in the case of a child. The greatest care should be taken in all cases not to use the least force in introducing the instrument, as otherwise serious consequences might result.

In conducting the examination of the meatus, the first object is to study the light, next the position in which to place the patient and mode of handling the auricle, and lastly, the introduction of the instrument.

A good strong natural light is at all times preferable to an artificial one, more especially where the patient can be placed so that the rays of the sun will fall obliquely into the speculum. The auricle must be gently raised with the left hand, drawing it outwards and forwards, and with the right hand introducing the speculum, taking care to have the set ready so that the most suitable size may be selected; by these means, with practice, no difficulty will be experienced in making a complete examination of the meatus auditorius externus and membrana tympani.

Should the surgeon unfortunately not be able to obtain a good natural light, he must resort to artificial means. Lamps and reflectors of many kinds have been invented for illuminating the auditory passage, and we have tried many of them, but the one we find of most service is the Author's, made by Mr Hutchinson, Surgical Instrument Maker, Sheffield, represented in the Frontispiece.

All thinking surgeons must know that in the examination of these parts the colour they present is frequently the only means of arriving at or forming any diagnosis of the disease; the advantages therefore of a natural, and disadvantages of an artificial, light are very evident.

INFLAMMATION OF THE EXTERNAL AUDITORY PASSAGE.

Inflammation of the external auditory passage is a very common affection, and is of a much more serious nature than it is generally supposed to be.

It may be brought on by the introduction of any hard

substance into the canal, by irritating applications, or by exposure to cold, and it may also be produced by infection with gonorrhœal poison. The symptoms of acute inflammation of the meatus are, heat, swelling, and dryness of the part, with pain more or less severe; there is generally soreness of the head on pressure; this is, however, a symptom present in all inflammations of the tympanum and internal ear; the hearing is frequently impaired, and tinnitus aurium present. The patient is restless, feverish, with a quick pulse: a muco-purulent discharge is generally established as the disease proceeds. On examination, the part is found of a bright scarlet tint, with considerable serous effusion; the membrana tympani is generally implicated. Acute inflammation of the meatus is a very common sequelæ in some constitutions of an attack of catarrh, in which cases, however, the disease is not generally very severe; it may also occur from wounds, injuries, &c.; the following cases will illustrate this affection and the treatment required.

M. H., aged 28, consulted us in March, 1859, for pain in the right ear, with a very great discharge. Four days previously she had been caught in a shower and had got wet through; in the evening a violent pain came on in the ear, to allay which some brandy had been poured into the meatus, of course with the effect only of increasing the disease; when dressing next morning she discovered that a discharge was present, which increased in quantity till it became very copious, when we were summoned to her. We found the meatus filled with mucus, after the removal of which with the syringe, the membrana tympani was seen red and highly vascular, and the external meatus swollen and red; hearing distance fourteen inches; three leeches were applied to the opening of the meatus, and subsequently a bread poultice; the ear was gently syringed out twice a day with

tepid water, and a mild mercurial alterative was prescribed. Under this treatment the parts were restored to a healthy condition, and the hearing returned.

CASE OF ACUTE INFLAMMATION FOLLOWING THE STING
OF AN INSECT.

Mr. G., aged 37, a solicitor, consulted us in August, 1859, for a pain in the right ear attended with discharge. He informed us that a week previously an insect had stung him on the ear, and caused him very severe pain at the time, which gradually settled down into a dull throbbing sensation, which was greatly increased upon eating, speaking, &c. Two days previously to seeing us he had discovered a slight discharge, and the pain for that day appeared much relieved, but on the following morning it returned with increased severity, causing him to seek medical advice at once. On examination, we found the auditory canal to be greatly swollen and inflamed, and also that the membrana tympani was in a similar condition, the discharge abundant but not purulent; hearing distance eighteen inches. The ear was ordered to be syringed out with a lotion of sulphate of zinc, one leech to be applied to the meatus, and an aperient draught to be taken at night. In ten days the parts resumed healthy appearance, the discharge had ceased, and hearing had become good.

W. S., aged 5 years, was placed under our care in November, 1859. The child was suffering great pain, was hot and feverish, and a muco-purulent discharge was pouring out of the left meatus in great quantity. After syringing the ear, we found the auditory canal and membrana tympani of a florid red colour, with white specks scattered over. She could only hear the watch at two inches distance. The disease in this case had been aggravated by want of cleanli-

ness. We ordered the ear to be bathed twice a day in warm water, afterwards gently syringed out; one leech was applied to the meatus every other day for a week, followed by a bread poultice, and a mild aperient was ordered with good diet. The child gradually recovered her hearing and the parts their healthy appearance.

CHRONIC INFLAMMATION OF THE EXTERNAL AUDITORY
PASSAGE.

This disease generally extends to the membrana tympani, although it may exist alone. It is not attended with discharge, on the contrary, the passage is usually dry, with a deficiency or total absence of the wax. It is often the result of acute inflammation, in which case the parts are weak and irritable, and like it may be brought on by cold, irritating substances and similar causes. There is very little sensation in the passage, a slight itching and tingling, with heat occasionally being the principal symptoms in that respect. The disease may occur in the healthiest subject, although more frequently it is associated with general debility and derangement of the health, and with an impure state of the blood. The derangement in the hearing is usually very great, and is influenced by the weather, the mental condition of the patient, and agencies of a like nature. The treatment consists in removing all constitutional disorder, and allaying local irritation. If the patient be of a weak and delicate constitution a nutritious and liberal diet with wine must be ordered, and the digestion and circulation improved by alteratives and tonics, and the secretion of the bowels promoted by mild aperients. The skin must be stimulated by warm bathing, the flesh-brush, and exercise. Counter-irritation may occasionally be beneficial, and change of air almost always so.

When the complaint is of a rheumatic or gouty origin, Mr. Harvey strongly recommends guaiacum and iodide of potassium, with bark and sarsaparilla, a mode of treatment deserving attention from that gentleman's general ability and great experience. Where the patient is strong and healthy, and accustomed to high living, a different course must be followed; the diet must be restricted to white meats with vegetables; calomel and aperients given to open the bowels freely, followed by alteratives; mercury in small doses at night, with a saline draught in the morning, will prove advantageous.

In giving mercury great care must be taken not to induce the slightest approach to ptyalism, the indication in view being to keep up for a certain time, according to the requirement of the case, a continued gentle action.

When inflammation of the tissues of the external auditory passage is continued for a length of time, it produces a narrowing or contraction of the canal and almost entire closure, causing a serious "diminution in the hearing power. Tinnitus aurium is perhaps one of the most constant and distressing features of this disease, and will generally be found associated with chronic inflammation of all parts of the ear.

CASE.—Miss J. A. R., aged 34, consulted us in September, 1858, for deafness in each ear, with distressing noises; she ascribed the disease in the first instance to a cold, but it had come on so gradually that she could hardly give any account of it; for four or five years the defect was so slight, she said, that she thought nothing of it; after that period it increased slowly until the time when she consulted us, when the hearing power on the right side was only three inches and on the left one inch. We ascertained upon close questioning that she had been subject to pain in the ears

before she noticed the deafness, and also the noises in the head. On examination the meatus was found to be perfectly dry, of a pale yellowish colour, and so narrowed that we could only introduce a No. 2 speculum. The tragus and antitragus were much thickened, and also the membrana tympani which was insensible to the touch. She was subject to sick head-aches, and complained very much of loud and constant noises in her head and ears, but with that exception her general health was good. We applied daily to the meatus and the membrana tympani a solution of nitrate of silver (gr. v. to ʒj.) and painted the mastoid process with iodine paint. The meatus gradually increased in size so as to allow the introduction of the No. 5 speculum, and it assumed a more healthy appearance; the opacity of the membrana tympani was also diminished. The ears were gently syringed every week to bring away the scales which peeled from the side of the meatus and membrana tympani, and after two months the hearing power was increased on the right side to ten inches, and on the left to six inches. We now discontinued the counter-irritation, but applied the nitrate of silver once a week, and ordered her the tenth part of a grain of bichloride of mercury with bark and extract of rhubarb twice a day, which she took with short intervals of omission for three months, during which period the meatus and membrana tympani became healthy, and the ceruminous glands threw out a plentiful secretion of wax. The tinnitus aurium still continued up to this period, although not so intense in its character. Her hearing power was improved on the right side to eighteen inches, and on the left to fifteen inches, at which it continued stationary for twelve months, and the last account which we received of the patient was that the tinnitus aurium had quite disappeared except when she had a cold, or was otherwise unwell.

This lady will probably never regain a greater degree of hearing power ; she is, however, quite content with what she has, and in fact, considers herself quite cured. The success obtained is mainly owing to her own intelligence and perseverance, aided by a good constitution. It very seldom occurs that similar cases terminate so favourably. Abscess in the external auditory passage is a very frequent result of inflammation and may occur in all parts of it, and spread into the tragus and the mastoid process. The pain is always of a very severe character, the redness and swelling great, and tinnitus aurium is usually present ; the pain increases at night and the patient is very feverish and restless. The approach of suppuration may be known by a feeling of weight, the tumour becoming softer, losing its high colour, and its centre beginning to point ; this termination should be promoted by poultices of bread or linseed. Should the abscess not burst quickly, and the constitutional symptoms become severe, it must be punctured with a lancet, and the matter allowed to escape into a large soft poultice, which may be continued till the pain subsides. The constitutional treatment must be regulated according to the nature of the case ; if the suppuration continue profuse, astringent lotions, tonics, and good diet are indicated. The condition of the membrana tympani must be carefully watched.

Chronic abscesses are so slight that for some time their existence is not suspected. Unlike the acute, which are generally superficial, they are deep-seated. They are usually the result of slow or chronic inflammation, or disease of the mastoid process of the temporal bone. They are free from pain, redness, or swelling, unless accidentally inflamed. The treatment is to amend the general health by nutritious diet, with wine and malt liquors in moderation ; free exercise in the open air, with light and well ventilated rooms, are im-

portant points of consideration. Daily use of the warm bath and friction of the skin, with judicious use of cod-liver oil, bark, and iron. The absorption of the matter may generally be procured by the use of stimulants and counter-irritation. Should however the tumour enlarge, it must at once be opened to allow the matter to escape, when in favourable cases the abscess will heal up.

CASE.—Captain B., after spending the evening in a warm and crowded room, walked a few yards to his carriage, the night being very cold and windy, without any covering on his head. He was very restless all night, and felt occasionally darting pains in his head and ears. In the morning a violent pain set in while he was dressing, and he at once summoned us. We found him feverish, with a furred tongue, and very deaf. He complained of an excruciating pain in both ears and at the back of the head. On examination we found the meatus completely swollen up, and so painful that he would not allow us to introduce the speculum; it was very red, and the swelling felt hard. We prescribed a dose of calomel, followed by a purgative, and applied a large soft warm poultice to each ear, to be changed every two hours. On visiting him in the evening we found the swelling much abated and softened, and not so high-coloured; the pain also was easier, although a throbbing sensation continued. The bowels had been freely opened and the feverish symptoms had disappeared; we gave him a small dose of opium, and ordered a poultice to be put on, the last thing at night. He slept well, and in the morning said he felt no pain in either ear, which was explained on removing the poultice by finding that the abscess had burst, and plentiful suppuration had taken place. The cavity presented a healthy appearance, and healed in a few days. The deafness, which was doubtless caused by the closure of the passages, was no longer present, and no further ill consequences followed.

CASE.—Mrs. W. sent for us in January, 1860. On arriving we found her suffering severely, with a great degree of fever and irritation present. On inquiry we learned that for five days she had had a violent pain in the right ear, with noise in the head, which she attributed to a cold from which she was suffering. She had applied warm oil and roasted figs, and had taken purgatives, still the pain continued, and, to her great alarm, she became very deaf on that side, in consequence of which we were sent for. We found deep in the meatus a small pointed abscess, very red in colour, and that the surrounding parts were much swollen. We punctured the abscess with a lancet in the pointing part, afterwards applying a warm bread poultice, continuing it till the pain subsided, giving at the same time a tonic aperient. The cavity not contracting, we applied a solution of sulphate of zinc, and ordered a liberal diet; under this treatment it healed in four days. When the swelling subsided we found the membrana tympani much inflamed, for which two leeches, which were allowed to abstract blood freely, were applied to the external meatus. After the inflammatory symptoms had abated we applied the nitrate of silver solution to the whole surface of the membrana tympani.

For a month or two after this attack the hearing power was not so acute as previously, but with attention to the condition of the auditory passage, membrana tympani, and general health, she gradually regained full possession of that faculty.

CASE OF CHRONIC ABSCESES.—Master H. T., aged 8 years was brought to us in June, 1859, for deafness. He was an unhealthy, dull, heavy-looking boy. Four years previously he had had the scarlet fever, which left him deaf with a discharge from both ears; the discharge had ceased for the last twelve months, his hearing however becoming worse.

On examination three abscesses, not larger than a small pea, were detected in the meatus; there was no pain even on pressure, neither was there any swelling nor redness. The wax of the ear was entirely absent, and the membrana tympani dry and white. Counter-irritation, to procure absorption of the matter, was ordered, and the walls of the canal and membrana tympani were daily touched with a solution of nitrate of silver in water (gr. x. to ʒj.). Cod-liver oil was ordered, varied with iron and quinine, daily bathing in tepid water, with use of flesh-brush afterwards, and regular exercise in the open air. His health improved, he became lively and active, and ultimately, after a long course of treatment, regained his hearing.

Ulcers of the external meatus are generally the result of badly-treated abscesses where they have not been properly healed from the bottom, or they may occur from disease of the mastoid portion of the temporal bone. When indolent they have a polished surface of a dirty white colour, with raised edges and a slight thin discharge. In this state they may continue for years, causing little inconvenience beyond that arising from the continuous discharge, which being usually so slight is scarcely regarded, and the deafness; but from any irritation they are liable rapidly to enlarge, causing sloughing, followed by destruction of the neighbouring parts. The membrana tympani becomes quickly involved, and if the disease be not checked the destruction of that part is certain. Next the tympanum and its appendages become involved, and the inflammation extends thence to the vestibule, cochlea, and all parts of the labyrinth, until the auditory nerve, having become implicated, communicates the disease to the brain. The surgeon must first determine the exact situation of the ulcer, and then proceed to heal it properly. On this point too much stress cannot be laid, as medical men fre-

quently recommend patients to let the discharge continue, and again tell them it will stop of itself. This gross ignorance illustrates very forcibly the neglect of aural surgery in the profession. If a person consult a medical man for an ulcer in his leg, the surgeon at once proceeds to treat it actively, and does not recommend it to be left to cure and heal itself. If it be essential to do this in a remote part of the body, how much more so is it necessary in the external meatus, where, if neglected, the ulceration may, and often does, extend to the brain, with fatal consequences ?

The general rules to be followed in such cases are to promote the vigour of the constitution by nutritious diet, wine and malt liquor in moderation, and tonics ; to remove any source of irritation, to procure the destruction of the ulcerated surface by strong caustics, and to prevent the lodgment of matter.

CASE.—Miss B., aged 25, consulted us in January, 1860, for deafness in one ear with a slight discharge. She had been deaf ten years, the loss of hearing having supervened upon an attack of scarlet fever. On examination we found in the external meatus a small fistulous ulcer, evidently the result of an abscess not thoroughly healed ; the discharge was of a whitish colour, very thin, and small in quantity. She had no pain nor inconvenience except that arising from the deafness ; as to the discharge, she appeared to consider it of very little importance. We prescribed quinine and sulphuric acid and good diet, with three glasses of port wine daily, and dressed the ulcer with an arsenical lotion on lint (liq. arsenicalis, ʒss., aq. distill. ʒj.) every day, previously syringing the ear with water to keep it perfectly clean. Under this treatment, in two weeks, the discharge ceased and a healthy surface formed, which was speedily healed with a simple lead cerate. The hearing power gradually improved

to twenty-six inches distance. Ulcers of a syphilitic origin forming in the meatus may be known by their rapid progress, irregular yellowish surface, profuse bloody discharge, and great pain, generally attended with fever. In addition to the former treatment, the constitution must be brought gently under the influence of mercury, and its action be kept up for some time. Opium may also be given to allay the pain, and mild stimulants applied with a view to exhaust the irritability of the parts. Should this treatment not be successful, the diseased surface must be destroyed by caustics. The arsenical lotion will be also found a very efficacious remedy, producing often, after all other means have failed, healthy granulations and cicatrisation.

CHAPTER V.

POLYPI.

INSTRUMENT USED IN THE EXTRACTION OF POLYPOID GROWTHS.—WOOD-CUT OF INSTRUMENT.—POLYPOID GROWTHS: CASES.—CANCEROUS TUMOURS: CASE RECORDED BY MR. WILDE.—DISEASES OF THE CERUMINOUS GLANDS.—ACCUMULATION OF WAX: CASE.—EFFECT ON MEMBRANA TYMPANI: CASE.—DEFICIENCY IN THE SECRETION OF THE GLANDS: TREATMENT.—FOREIGN BODIES.—THE USE OF THE SYRINGE.

BEFORE commencing our description of the morbid growths, spoken of indiscriminately as polypi, we will explain the construction of the instrument, *fig.* 6, which we use in extracting, and also in the various operations referred to in the preceding chapter. In the selection of instruments, one great point to be attended to where practicable, is to have them simple and portable in form, so that a complete set may always be carried about; another is, to avoid confusion in their arrangement.

The instrument represented in *figs.* 6, 7, 8, 9, 10, 11, 12, might justly be termed the self-acting lancet, and contains, in addition to the lancet, a camel-hair brush, and four-bladed forceps.

Fig. 6, the instrument ready for use with the lancet.

Figs. 7, 8, 9, 10, 11, 12, represent the instrument taken to pieces.

Fig. 7, the lancet. 8, four-bladed forceps. 9, camel-hair pencil. 10, spiral spring. 11, nut to regulate the length of lancet to be used. 12, thumb-piece.

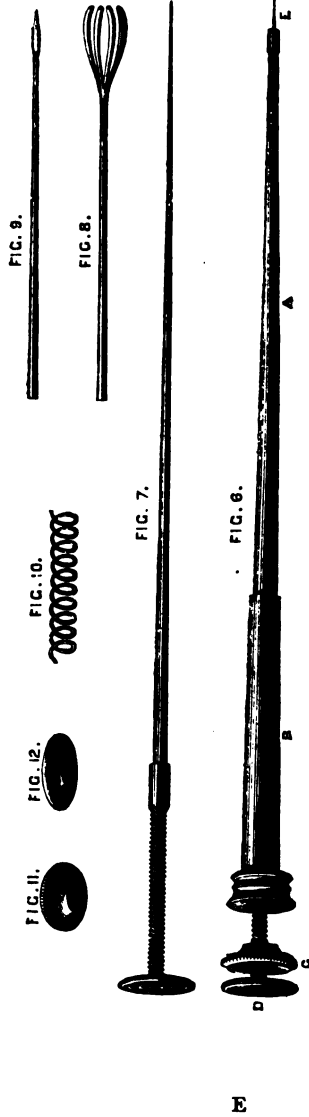

A. The tube.
B. Dilated part of the tube containing spiral spring.
C. Small nut to regulate the length of lancet to be used.
D. Small nut called the thumb-piece, which is pressed upon in operating.
E. Extremity of the lancet seen emerging from the end of the tube.

Fig. 13 shows the surgeon operating upon an abscess on the membrana tympani, with the lancet. To apply caustics or any other application to the same or adjoining parts, the camel-hair pencil is introduced into the tube instead of the lancet; but where a polypus is to be extracted, the four-bladed forceps are so constructed that they can be introduced into the tube and worked on the same principle as the lancet, so that when the thumb-piece is pressed the blades are thrown open and are made to surround the neck or extremity of the

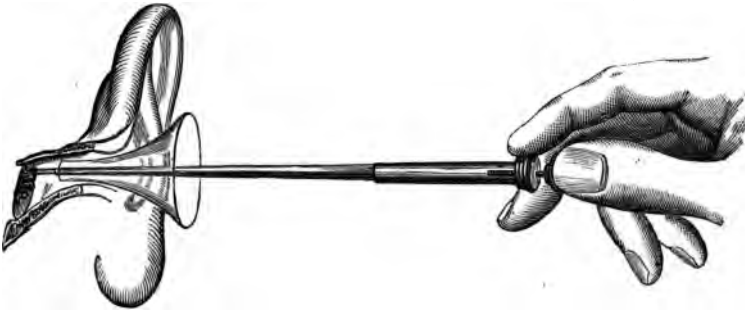
Fig. 13.

polypus, as may be most convenient, and the moment the thumb is taken away from the nut the blades firmly grasp the fleshy substance, which is brought away without the slightest inconvenience.

Polypoid growths are the frequent result of inflammation of the meatus, membrana tympani, and cavity of the tympanum. They are found attached both to the anterior and posterior wall of the meatus, and also, though rarely, to the membrana tympani, and are always attended with a discharge (generally very foetid). They are usually painless, except when they grow very large, when they cause head-ache, giddiness, and other symptoms of congestion. The common polypus found in the ear is generally composed of fibro-

plastic cells, though there are other varieties. In colour, before extraction, they vary from deep red to pink. Their shape is from that of a small round body to a large lobulated mass. Their treatment consists in removal, and preventing, if possible, their return. The instrument, *fig. 6*, is the one employed by us when we wish to remove the growth by the lancet, and we believe it to be the best possible contrivance for the purpose. After the bleeding has stopped, the ear should be gently syringed out with warm water, in order that we may see if any of the polypus remain, in which case, it and the roots should be touched daily with solid nitrate of silver until all unhealthy appearances have disappeared.

CASE.—J. B., a female, applied at the National Ear Institution in April, 1860, for relief in a case of deafness in the right ear attended with offensive discharge, from which she had suffered five years; these symptoms had made their appearance directly after a violent attack of ear-ache. On examination we found the external meatus filled with a thick yellowish discharge, and, on removing this matter with the syringe, a polypus of dark red colour was seen attached to its anterior wall. The hearing power on the right side, when tested with the watch, was half an inch, and on the left twenty inches. The growth was removed by the four-bladed forceps (see *fig. 14*), and was about the size of a small cherry. When the bleeding subsided the ear was gently syringed with warm water, and the cut surface touched with solid nitrate of silver; in a few days the discharge ceased. The membrana tympani was uninjured, but very opaque; to reduce which morbid condition it was daily touched with a solution of nitrate of silver; a course of tonics was prescribed, and in a few weeks the hearing power was perfectly regained, and she was discharged cured.

CASE.—Rev. A. H., K., aged 37, of delicate constitution,

consulted us for deafness in both ears, with discharge from the right ear. The disease was first perceived six years since, after a severe attack of influenza, but was so slight that no

Fig. 14.

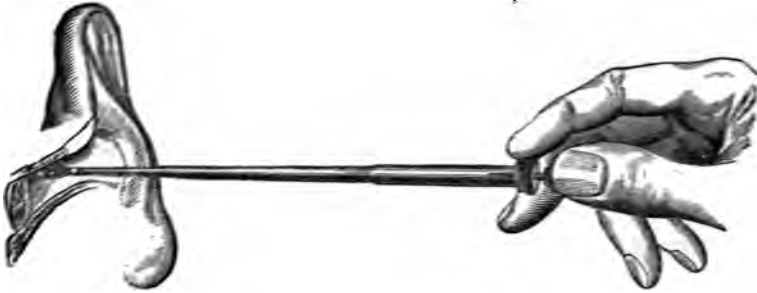

Vertical section of external auditory passage, showing the extraction of a polypus from the osseous portion.

notice was taken of it. Three years before seeing us the discharge commenced, and gradually increased, during which time the hearing, he said, had daily become worse. On examination, we found the right meatus entirely filled with a large polypus, attached to its osseous portion; the left passage was dry and scaly, and the membrana tympani white and opaque. We extracted the polypus without difficulty by the aid of the four-bladed forceps (see *fig. 14*); after which operation the hearing power was greatly improved. The discharge ceased in a few days, and by the application of nitrate of silver in solution daily to each membrana tympani, with a course of alteratives and tonics, the hearing ultimately strengthened to the extent of distinguishing the tick of our watch at twenty-six inches distant on each side.

CASE.—J. S., aged 41, of good constitution, consulted us for excessive deafness, with discharge, in the left ear. She complained bitterly of loud noises in the head, pains, giddiness, and occasional sickness. She could only hear the watch

on the left side, when pressed against the head, and on the right at one inch distant. On examining the right meatus, we found that it was filled with dry scales, that its diameter was much contracted, and that the membrana tympani was white and opaque; the left meatus was filled with a smooth tumour of a palish red colour, extending into the concha. We found it was attached to the membrana tympani, being able to pass our probe completely round it down to the surface of the membrane, where we could feel its point of attachment. The discharge was of a very offensive nature. The patient being in excellent health, with no pain in the ear or inconvenience, except that which clearly arose from the tumour, we decided to remove it with the four-bladed forceps (see *fig. 15*), which was accomplished with little pain

Fig. 15.

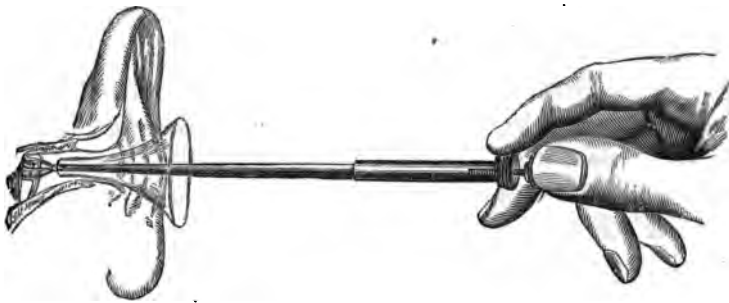

Vertical section of the external auditory passage, showing the extraction of a polypus from the membrana tympani.

to the patient. The bleeding was inconsiderable. To destroy the roots on the membrana tympani, and prevent future growths, we touched it every second day with the solid nitrate of silver. After the extraction of the growth the distressing noises and pain in the head, giddiness, and sickness were never again experienced, and the discharge ceased within a

week of the operation. The treatment of the right ear consisted in simply syringing it with warm water every second day, and afterwards painting the entire surface of the meatus and membrana tympani with a solution of nitrate of silver in water (gr. x to ʒj.); the parts gradually regained their healthy appearance, and the hearing power was regained.

Cancerous tumours projecting from the meatus, of which the symptoms are quick growth, bleeding fungating surface, pain, and debility of the constitution, should not be removed by the knife, or forceps, or interfered with in any manner which might produce irritation; in such cases the utmost that can be done is to relieve pain, and improve the constitution by every possible means. The following case recorded by Mr. Wilde is one of the most interesting instances of malignant disease of the meatus with which we are acquainted:—"A female, aged about 50, whose brother I subsequently heard had died of cancer, consulted me some years ago on account of a polypous growth in the right ear, attended with a remarkably foetid discharge of many years' duration. She had an unhealthy look, and complained occasionally of giddiness, loss of rest, and sickness of stomach. The otorrhœa having increased considerably of late, she was anxious to have it removed if possible. The meatus was filled with a reddish-brown flabby polypus, much darker in colour than I had ever seen before. On examination I found it firmly attached to the lower and posterior wall of the external meatus, and I could not lift it up or pass a probe round it, as can generally be effected in ordinary cases of polypus, no matter of how long standing. Neither did it present the circular protuberance which forms in cases of fibrous polypus as soon as the morbid growth has cleared the meatus and commenced to mould itself into the shape of the external aperture. It was not possible to examine the canal, so com-

pletely did the morbid growth fill it up ; but a probe could be passed with facility all round its upper and anterior surface. These were the only symptoms that presented when I first saw her. She stated that she had latterly suffered from pain in the ear, and that upon several occasions during the past year pieces of the polypus had come away. Finding it impossible to pass a snare round it, I removed a portion of it with a scissors; and the hæmorrhage which followed was inconsiderable. Subsequently I attempted to lessen the growth by the application of nitrate of silver applied to its surface, and also by passing a small sharp-pointed probe coated with the caustic through its surface. Constitutional treatment calculated to improve the patient's health was not neglected ; and for a short time the local appearances improved, but I was never able to clear the meatus of the morbid growth. My attention was soon attracted by the rapid progress of the fungoid mass, which increased almost as quickly as it was removed. In the course of a month the serious nature of the disease manifested itself. The growth from the meatus assumed a livid unhealthy colour. The auricle was pressed forward and outward by a fluctuating tumour over the mastoid process; this I opened, and a quantity of dark-coloured foetid matter was evacuated, and considerable relief experienced for a short time. Paralysis of that side of the face next appeared ; several large abscesses formed along the course of the mastoid muscle ; well-marked rigors ensued, and the general health gave way, the characters of malignant disease being strongly marked in the countenance. Convulsions, followed by long fits of coma, ensued, and the pain at times was most excruciating. The post-aural and infra-aural regions rapidly enlarged, the integuments of the mastoid region gave way, and a large fungoid mass sprouted therefrom, which in a few days attained the size of a lemon ;

the fœtor was the most intolerable and sickening I ever smelled, and death put an end to her sufferings in about three weeks after the external appearance of the fungus, which presented all the characters of true malignant disease."—*Wildé's Aural Surgery.*

DISEASES OF THE CERUMINOUS GLANDS.

These glands are subject to every variety of disease to which the glands of the skin in other parts of the body are liable, but their disorders are generally much more sudden in their nature.

Perhaps of all the diseases of the ear, the surgeon considers those happening in these little bodies more simple than any other; for instance, in examining the ear, and finding apparently nothing more than an accumulation of wax in the passage, and concluding that merely syringing and bringing it away will perform a perfect cure, he very seldom troubles himself about any other symptoms; forgetting, in the first place, that some peculiarity of constitution must exist where a secretion the size of a small marble is formed, as frequently occurs, in the meatus in one night, and in the next the treatment, which is absolutely necessary after this substance is brought away; in another case, where the secretion has been in the meatus for ten, fifteen, or twenty years, the surgeon frequently forgets the disastrous consequences which may result from suddenly bringing it away without following up its removal by proper treatment subsequently. Patients of a weakly constitution, and who perspire profusely, are liable to become suddenly deaf in consequence of the rapid action of these glands; and in some remarkable instances we have known the passage to be completely closed in a few hours. Where such is the case the immediate removal of

the secretion, with constitutional treatment to regulate the action of the glands, will remedy the deafness.

CASE.—In June, 1860, we were summoned to Miss T., aged 18, who, while suffering from a slight cold, had had her hair cut and washed; to her great surprise, one hour afterwards she became quite deaf in both ears. On examination we found the meatus in each ear completely stopped with wax of a light brown colour, rather soft, and much mixed with hair, cuticle, &c. We syringed the ears with warm water, bringing away all the secretion, and with slight constitutional treatment the hearing was at once regained.

Should it happen that an accumulation of wax has been for any length of time in the external auditory passage, it will usually be found near the membrana tympani, and, completely moulded to the shape of the part. It becomes exceedingly hard, and this, together with the fact of its being complicated with hair and cuticle, renders it exceedingly difficult to bring away. In such a case the external air is completely excluded from the membrana tympani, the functions of which ceasing, its external layer becomes thickened, and the functions of the tympanum suspended. The parts become so accustomed to the presence of the foreign body, that to attempt its removal without some previous precautions might cause serious mischief to the neighbouring structures, by admitting the action of air to a part from which it had been so long excluded. It is important, therefore, in all such cases, firstly to apply such an application as will soften it and bring it under the control of the syringe; and secondly, after it has been brought away, to see that the ear is well protected from cold and the action of the atmosphere, until the parts have again become accustomed to their influence; thirdly, to reduce the thickening of the membrana tympani.

CASE.—Mrs. J., aged 50, applied at the National Ear

Institution in July, 1859. She stated that she had been deaf for fifteen years: she never had any pain in the ears, but was troubled with constant and distressing noises in the head, with occasionally a swimming and dizziness; for the last five years the noises had not changed in character, but the deafness had greatly increased. We found the throat healthy, the Eustachian tube pervious, and the general health excellent. On examination the external meatus was found to be completely stopped up with wax on each side, very far down in the passage, in fact, at the innermost part of the external meatus, and in close contact with the membrana tympani. It was of a dark brown colour and exceedingly hard, and much mixed up with hair. We applied olive oil and liq. potassæ in equal proportions daily for a week to each ear, which had the desired effect of softening the mass, and enabling us to bring it away, without any force, by the syringe. After its removal the hearing became slightly although very little, improved, but the noises were considerably diminished. Upon examination the membrana tympani was seen to be very dry, opaque, and tense. We applied a solution of nitrate of silver daily to it, and ordered the twentieth part of a grain of bichloride of mercury in bark twice a-day for a month, during which period the membrana tympani assumed its elasticity and natural colour, and the hearing power was regained to the extent of twenty-six inches on each side.*

A deficiency in the secretion of these glands is generally the result of an inflammatory condition in the neighbouring structures, which may be situated either in the deep, or superficial, but more frequently in the latter; their healthy action will be promoted by the employment of remedies for

* The reader must bear in mind that the sound heard in all cases in which the extent of the hearing power is referred to, is the ticking of a watch.

the removal of this diseased state. Should their secreting power be checked however for any length of time, a thickening of the external layer of the skin, and also of the cuticular layer of the membrana tympani, would be the consequence ; dulness of hearing would then result, not so much perhaps from the deficiency of the secretion in itself, as from the derangement its absence would occasion in the parts which it supplies,—a clear proof that the prevention of the entrance of dust, insects, and other foreign bodies into the ear, is not the only function which it has to perform. We believe that there is no confirmed case on record in which a total absence of the secretion could be shown to have existed without the sequel of more or less dulness of hearing. Such cases are very difficult to cure, especially if of long standing, and require a long course of patient and judicious treatment ; alteratives, diaphoretics, stimulants, and tonics, may be tried, and the meatus and membrana tympani painted with iodine paint ; small doses of the preparations of iodine given internally, often produce good results in very unfavourable cases.

Foreign bodies in the external meatus most generally occur in children : those we have the most frequently found have been, peas, beans, cherry-stones, small pebbles, beads, bits of slate pencil, tobacco, cotton wool ; and often pins, and other similar substances, which have slipped into the ear while the patient has been engaged in picking it ; a practice which cannot be too strongly condemned, giving rise to many of the forms of disease mentioned in previous chapters, independently of the risk of rupturing the membrana tympani, and of the substance itself finding its way into the cavity of the tympanum, where dangerous irritation, and sometimes death, has followed from such apparently simple causes. In all cases where a foreign body is suspected to be in the ear, the

surgeon must, by a careful examination, ascertain its presence beyond a doubt ; it being a very common occurrence, with every aural surgeon, to have children brought to him in order that he may remove a substance from the ear, which has in reality never been introduced, and not unfrequently dangerous inflammation is set up by poking about the passage with instruments to find what never existed save in imagination.

If a foreign body lodge in the first part of the external meatus, it can easily be removed with the syringe and warm water ; should it, however, be in the third portion, instrumental aid is necessary, and we strongly advise no surgeon to attempt its removal in children without having them under the influence of chloroform ; firstly, to relax the muscles, and cause the parts to give way sufficiently to admit of the required dilatation to bring the substance away without injury to the parts ; and, secondly, to have the child perfectly quiet during the operation. Our experience tells us that the attempt to remove a hard substance from the ear of a child, where the substance is of large size, and in connection with the membrana tympani, without this precaution, is much more dangerous than might be imagined by persons who are not in the habit of seeing such cases ; and there is no doubt that many cases of rupture of the membrana tympani have been caused by the surgeon attempting to remove these substances from a frightened screaming child with the additional embarrassment frequently of the presence of a fainting mother. After the patient has been brought under the influence of chloroform, the forceps used in the extraction of polypoid growths will be found well adapted to bring away any body from the external meatus. Insects will at times find their way into this passage, and cause great irritation ; they may be readily brought away with the syringe. Should any insect become lodged in the meatus,

which, by its bite or sting, might occasion inconvenience or danger, a small quantity of glycerine, or some other unctuous liquid, should be dropped into the passage as soon as it can be obtained ; by this means the insect would be destroyed, and its subsequent removal facilitated by its envelopment in the fluid.

Before closing this chapter, a few words on the use of the syringe may not be out of place, much disappointment being frequently experienced, owing to its improper handling.

The patient must be placed in a suitable position for the light to fall into the ear ; a glass vessel, formed to fit to the shape of the under part of the ear, placed in the hand of the attendant. Next, the surgeon with his left hand must raise the auricle, drawing it outwards and forwards, by which means the passage is straightened. He will then take the syringe in his right hand, the body being held between his two forefingers so that he can work the piston freely with his thumb. The mouth-piece is applied to the upper part of the meatus, so that the stream of water is made to take a course round it, and to pass behind any substance that has to be removed, bringing it away under the mouth-piece of the syringe. Any opposition to these rules will not be followed by success, as the natural position of the parts plainly indicates. In the first instance, if the auricle is not drawn outwards and forwards, and the passage straightened, the fluid will not enter at all. Secondly, if the mouth-piece of the syringe is held in front of the passage, instead of at the upper part, the substance will be driven in and forced against the membrana tympani, setting up a dangerous irritation in that membrane and neighbouring parts.

In syringing, where only water is required, we recommend four distinct vessels, a jug of hot and cold water, a washhand basin, and the glass already mentioned to fit behind the ears.

The syringe itself should be of silver. We strongly object to the ear-spout on account of its interfering with the surgeon's hand, in addition to which it gives rise to the inconvenience of allowing the water to run down the patient's neck. *Fig. 16* is a syringe, introduced to our notice by Mr. Hutchinson of Sheffield, which we have found very useful in many cases.

Fig. 16.

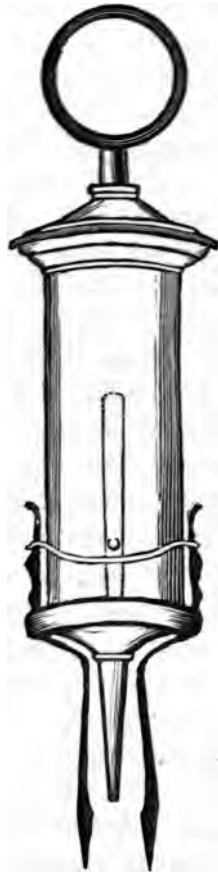

CHAPTER VI.

DISEASES OF THE MEMBRANA TYMPANI.

INFLAMMATION : ACUTE — SYMPTOMS — TERMINATION — TREATMENT — CASES
—CHRONIC INFLAMMATION.—NERVE PAIN, OR NEURALGIA OF THE EAR :
TREATMENT.—NERVOUS DEAFNESS.—TREATMENT OF CHRONIC INFLAMMA-
TION : CASES — THICKENING.— PERFORATION. — ARTIFICIAL MEMBRANA
TYMPANI.—OTORRHOEA : TREATMENT—CASES.

IN treating of inflammation of the membrana tympani we might divide and subdivide it into an almost endless number of varieties. These might again be distinguished as acute and chronic, subacute, syphilitic and strumous. We might again advert to each distinct layer of the membrane, and show how they might be affected with either variety of the above-named forms of inflammatory disease, and this both separately and conjointly. But observation and experience have tended to convince us that one layer is never diseased to any appreciable extent without implicating the others. For all practical purposes in the treatment of inflammation in this delicate organ it will be sufficient, therefore, to classify it under two heads only ; namely, acute and chronic.

ACUTE INFLAMMATION OF THE CUTICULAR LAYER OF THE
MEMBRANA TYMPANI.

This form is the result frequently of inflammatory action of the skin lining the external auditory passage. On examination, the membrane will be found of a bright red colour and swollen, and the auditory passage will also be seen to be in a similar condition. The patient complains of severe pain at the bottom of the passage, the pain being of

a very variable character : there is also soreness of the head on pressure, and as the disease proceeds, tenderness about the mastoid region. The tinnitus aurium is very distressing, resembling the boiling of a kettle, the ringing of bells, or concussion of metals ; besides this symptom, sneezing, coughing, head-ache, sleeplessness, and in bad cases, delirium, may be present. A muco-purulent discharge is generally poured out in large quantity ; ulcers may also be found frequently on the membrane, and perforation, either from abscess, sloughing or ulceration, occasionally takes place ; and if the inflammatory process is not checked, it may lead to the destruction of all the layers of the membrane, and implicate in the process the tympanum with its appendages. These cases in the severe form are not unfrequently mistaken for inflammation of the brain, and treated as such.

It may suffice briefly to point out what might be the consequences of acute inflammation in this delicate and important structure, and the great importance of decided treatment being at once adopted. If we may use the word "generalship" on the part of a surgeon, it is in these cases particularly where it is called into action. A perfect knowledge of his case, or, in other words, a correct diagnosis, coolness, with full command over his patient, are absolutely necessary ; and they who do not possess all these advantages, together with opportunities of watching similar cases, had far better leave them alone. The tympanum becoming implicated would communicate the disease to the throat and nose. Again, should the internal ear become involved, the membrane closing the two orifices, known as the fenestra ovalis and fenestra rotunda, might become destroyed, and the disease be transmitted thence to the cochlea, vestibule, semi-circular canals, and auditory nerve. In very severe cases the petrous portion of the temporal bone becomes diseased, and

thus establishes a ready communication with the membranes of the brain, which ultimately leads to the death of the patient. The treatment of acute inflammation of the membrana tympani is similar to that for acute inflammation occurring in any other part of the body, and may be summed up, briefly: bleeding, purgatives, antiphlogistics, diuretics, narcotics, sedatives, attention to diet, calm mind, perfect rest, confinement to a warm room, warm fomentations, and vapours to the inflamed surface; stimulants and astringents to the mucous membrane, and counter-irritation when the activity of the disease is subdued.

CASE.—During last winter, we were called in to Colonel W., who had been suddenly attacked with violent pain in the right ear. A week previously he had been skating, and unfortunately fell into the water, from which he was with difficulty rescued. Either carelessly or unavoidably, he remained in his wet clothes for some time, and was subsequently attacked with a severe cold; this continued for seven days, when an excruciating pain suddenly commenced at the bottom of the auditory passage. Laudanum, warm oil, and warm fomentations were tried, with the effect only, according to the patient's account, of increasing the pain. On being introduced to him, we observed that his face was flushed, that his eyes were exceedingly sensitive to light, and that his countenance wore a haggard expression. On examination the auditory passage was found to be much swollen, the membrana tympani of a deep scarlet hue, with the blood-vessels much dilated; a distinct dark red line, which was doubtless one of the vessels distended with blood, crossed the membrane; the hearing was slightly impaired. Five leeches were ordered to be applied immediately, two to the meatus, and three behind the ear; afterwards fomentations of poppy-heads and camomile flowers, to be succeeded by a large bread

poultice. Small doses of calomel and opium were administered every three hours. Great relief followed these measures, which continued till the following evening, when the symptoms returned with redoubled violence, and the hearing became very defective. Three leeches were immediately applied to the meatus, and their bites encouraged to bleed freely in a large warm poultice; the calomel and opium being continued every three hours during the night. The next morning our patient was better in every respect, the bowels had been well purged, the skin was cool and moist, the pupils were more dilated, the countenance was tranquil, and the membrana tympani had begun to assume a more healthy appearance. Blisters were applied behind the ears, and the calomel and opium continued till the gums were slightly affected; under this treatment the inflammatory symptoms were quite subdued, and the membrana tympani lost its vascularity, but the deafness still continued, accompanied by a slight sensation of noise in the ear. It was suspected that the cavity of the tympanum and Eustachian tube was implicated. The bromuretted vapour was applied to the tympanum through the Eustachian passage, and also to the throat: this method of treatment was attended with satisfactory results, all the bad symptoms disappeared, and with a course of tonics and attention to diet, the patient's health and hearing became perfectly restored.

CASE.—W. L. applied at the National Ear Institution in August, 1859. He stated that he had been afflicted with deafness for some time, which he ascribed to a bad cold, after which he had suffered from severe and constant pain at the bottom of the auditory passage. He had experienced a sensation of loud noises in the ears and head, and often suffered from violent pains in the head. On examination the membrana tympani on each side was found of a bright scarlet

colour, whilst it and the auditory passage were much swollen, and the blood-vessels on the membrane were greatly distended. A muco-purulent discharge, tinged with blood, was present. Three leeches were ordered to be applied to the meatus on each side, Dover's powder and purgatives were prescribed, and under this treatment the worst symptoms disappeared. The pain in the ears was greatly relieved, and also the noises and pain in the head. The membrana tympani presented a greatly improved appearance, and the discharge was lessened; a mild astringent lotion was ordered to be used for the ears, and small doses of calomel and colchicum were administered. At the end of ten days the inflammatory action was perfectly subdued, the discharge had ceased, and the hearing was much improved. The noises continuing, iron and quinine were ordered, and the bromuretted vapour applied to the tympanum through the medium of the Eustachian tube. The membrana tympani assumed its natural form and appearance, and in a few weeks the patient's health and hearing were restored.

A large number of similar cases might be adduced, in which there was no very great variety in either the symptoms, treatment, or results; but those which have been given will serve as well as twenty to illustrate the subject. We will therefore dismiss this phase of inflammatory disease, somewhat reluctantly, perhaps, because, on account of its common occurrence, we would desire to give every possible guide for its management.

CHRONIC INFLAMMATION OF THE CUTICULAR LAYER OF
THE MEMBRANA TYMPANI.

This is commonly the result of acute inflammation of that part. On examination the membrana tympani is found to be opaque, of the colour and appearance of parchment,

streaked with red, and almost insensible to the touch. This form of disease is usually painless, though in some cases a severe throbbing is felt occasionally at the end of the auditory canal. The tinnitus aurium is always very distressing and intractable. On account of the intermittent character of the pain, this disease is often mistaken for nerve pain, or neuralgia of the ear. The greatest care is required to make a correct diagnosis, as the treatment for one disease would aggravate the other in the event of a mistake being made. The peculiar appearance, and often collapsed condition of the membrana tympani, the tinnitus aurium, and the sequence of this disease upon acute inflammation, or severe ear-ache, will indicate chronic inflammation; whereas in neuralgia, which alternates without any apparent cause, and without any change of structure, the membrane remains of about the colour of the skin on the back of the hand. The treatment of neuralgia of the ear, as of all other nerve pain, consists in tonics, change of air, and the improvement of the constitution of the patient by every available means; while the treatment of the other disease just referred to must be such as we would employ for chronic inflammatory action generally.

Cases of chronic inflammation of the membrana tympani are usually of long standing, and are often described as "nervous deafness;" they are very difficult to manage, for even where there is a probability of cure, the long course of treatment required wearies out the patience of the sufferer long before a cure can be accomplished. Where the membrana tympani is thickened and opaque, the application to it of a solution of nitrate of silver will be beneficial: and if much vascularity exist, a leech may be applied to the meatus once a week. Very small doses of the bichloride of mercury alone, or combined with tonics and purgatives, continued for

two or three months, its action being carefully watched, will often promote healthy symptoms, and the hearing will improve considerably while the patient is taking it. In females the state of the uterine system must be attended to, and any irregularity, if present, be corrected by steel and aloes. In rheumatic and gouty cases, colchicum and guaiacum may be combined with the mercury. The evil to be combated in chronic inflammation is a deficiency of vigour in the parts; consequently, in all our treatment this must be kept in view. Counter-irritation is often useful, but to be so must be persevered in for a long time. A good and liberal diet will generally be required, with a moderate quantity of wine.

CASE.—Mary J., aged 23, presented herself at the National Ear Institution in September, 1859, for relief from deafness, and constant noises in the head, with occasional pain in the ear upon taking cold. Upon examination the membrana tympani was found to be much thickened, and of the colour of dirty white paper, with great dilatation of the blood-vessels in different parts. On introducing the probe it was found almost insensible to the touch. The hearing power on each side extended to about six inches distance. This patient was ordered the twentieth part of a grain of bichloride of mercury three times a day, which she continued for three months, with occasional intervals of ten days, and the membrana tympani was touched twice a week with the nitrate of silver; during this period the hearing power increased to ten inches distance. The membrane had assumed its natural elasticity and colour, in fact appeared quite healthy, and the ceruminous glands began to secrete slightly; the pain had ceased, but the noises continued. She was now put on a course of tonics; her hearing power at the present time is about eighteen inches distance.

CASE.—Rev. W. H. S. applied to us for relief in a severe

case of deafness, which he stated had been called by several medical gentlemen "nervous deafness," and from which he had suffered for ten years. On examination of the external auditory passage total absence of the secretion was found, with narrowing of the canal. The membrana tympani was of a light buff colour, much wrinkled, and insensible to the touch: when he had a slight cold he was subject to throbbing pain in the ear, and noises which varied exceedingly, sometimes resembling the rush of a stream of water, or the singing of birds, and not unfrequently the working of machinery. He was subject to violent head-aches, more especially after any excitement or study; at which times his hearing power was almost lost. He stated that when a youth he had been subject to violent attacks of ear-ache, and after such attacks a slight discharge always occurred. He had frequently applied to medical men for relief, and went through the whole category of ear-drops, oils and liniments. Finding himself worse generally after each fresh plan of treatment. His health was completely broken down; he was irritable, desponding, and nervous. His hearing power on the right side was one and a half, and on the left four inches distance. In this case if anything could be done it was solely by constitutional treatment, and all our endeavours were directed to improve his constitution.

In the first place, he was ordered a course of mild alteratives and purgatives, to maintain a regular secretion of the bowels, and put on a liberal diet, with two glasses of sherry daily, and one of good ale. When the action of the bowels became more regular he was given the sixteenth part of a grain of bichloride of mercury combined with bark and rhubarb, three times a-day, which mixture he took, with short intervals of omission, for four months, with marked improvement in his health. The noises and head-ache quite disappeared, and he

became cheerful and vigorous; at the same time counter-irritation was applied to the mastoid process, and the thickening of the membrana tympani reduced by a lotion of nitrate of silver. The auditory passage lost its contracted form, and assumed with the membrana tympani a healthy appearance. The hearing distance at the end of five months' treatment, was on the right side eight inches, and on the left ten inches; no more improvement taking place under this treatment, we concluded that the cavity of the tympanum was implicated, and the bromuretted vapour was passed through the Eustachian tube into the tympanum; and it was also used at the same time to the throat. Under this treatment combined with the former, long persevered in, the hearing power was regained to the extent of eighteen inches' distance.

Thickening of the membrana tympani with or without collapse is a frequent, indeed we might almost say constant, result of inflammation; it is very difficult of cure, especially if occurring in a debilitated constitution, and of long standing. The deafness is very great, and in collapse of the membrane incurable. If any traces of inflammatory action remain on the membrane, we may hope, by removing the morbid action, to improve the condition of our patient; and the means employed for chronic inflammation of the membrana tympani will be the most suitable. But if the membrane is dry, white, and tense, and the meatus in the same condition, and devoid of cerumen, little hope of improvement remains.

The treatment of opacity of the membrana tympani consists in applying to it a solution of nitrate of silver, grs. xv. to ʒj. of distilled water two or three times a week; counter-irritation over the mastoid process, and back of the neck, with constitutional treatment.

The following case was placed under our treatment by

Dr. Forbes Winslow, in October, 1860. Miss W—— had suffered from deafness many years; on examination we found the membrana tympani in each ear of a dense white colour, opaque, and thickened. She was unable to inflate the tympanum, owing to the obstruction of the Eustachian tubes.

To reduce the opacity of the membrana tympani, we painted it daily with nitrate of silver in solution (grs. xv. to ℥j.) and injected air into the tympanum through the Eustachian tubes. Under this treatment, the lady shortly regained her hearing.

PERFORATION OF THE MEMBRANA TYMPANI.

The membrana tympani often becomes perforated or destroyed, under certain circumstances of disease. These circumstances may be either accidental, or the result of inflammatory action: the former may proceed from violent efforts of sneezing or coughing, and from blows or injuries inflicted by the insertion of foreign bodies into the external passage. It is probable that this perforation may be found in individuals who, not having felt any inconvenience or difficulty in hearing, have not been conscious of its existence. It is said of some smokers that they will inhale the vapour of the tobacco, and then force it out again through the nose, and by the way of the Eustachian tube, through the ears. This could not be the case if the membrana tympani were not perforated. In some instances hearing has been improved by a perforation of the membrane, especially when it has become so inelastic in its nature as to lose all reciprocal connection with the vibrations of the atmosphere; in which case we may conclude that the air in the middle ear becomes a better conductor of the external impression than the inefficient and thickened membrane. The partial or total

destruction of this membrane may also result from inflammation and ulceration ; if the disease be checked, the wound will probably cicatrise, and the membrane will to a certain extent be replaced ; and this will occur even after the destruction of nearly the whole of the membrane. So long as any portion of the membrane remains, if the disease be removed, the probability is in favour of its cicatrising ; but if it become totally destroyed this cannot take place.

It has been imagined possible by mechanical means to replace this delicate portion of the auditory apparatus ; and, as in the case of a worn-out drum, it has been declared that a new drum-head may be fitted into the old frame, and the original perfection of the apparatus sustained. There is much truth in the little *reservation* made, that the experiment does not always succeed, and that only the initiated will be able to perform it successfully ; it would only be an act of charity to suppose that this statement does not contain all the truth. Like the swinging windows in the pantomime, through which harlequin and clown annually disappear, these holes are made to be jumped through ; it was never intended they should be seen through ; There would not be so much cause for complaint if all the failure consisted simply in inability to produce the results aimed at ; but this is not the case ; excessive irritation and inflammatory action are very frequently produced by this incessant chafing and probing in the auditory canal : were it possible to line it with metal, the continued friction would be almost enough to keep it bright, but unfortunately these delicate structures will not bear so much scrubbing and rubbing as a silver teapot ; and it would be a much more harmless occupation if this were substituted for the *ear mending* already alluded to. Nor is this the full extent of injury liable to accrue, if, in any instance, it should be imagined that fibrous material bears

the greatest analogy to the lost drum-head or tympanic membrane ; and if by any false process of reasoning it should be advanced, that, because externally it is one of the best of non-conductors, and a good resisting medium, it would prove an excellent artificial membrana tympani, and any one should be foolish enough to apply it to practice, what is to prevent its admission into the cavity of the middle ear ? We can picture to ourselves an enthusiastic young man, with the mystic four-lettered appendage newly added to his name, with all his honours green and fresh upon him; and with little else to do ; loosening the reins to a fervent imagination by his own fireside ; having read that a feather-bed will stop a cannon-ball which would splinter a log of wood, and concluding also that if nailed up against a closed door, or in a door space, it would equally exclude all external sound, we could imagine him plugging up all the key-holes with cotton-wool, saturated perhaps with warm water, and then congratulating himself upon the results. But by what logic can we trace his arguments further ? How can we o'erleap the bounds of reason, and declare with him : " These plugs of cotton-wool, see how admirably they deaden the vibrations of that odious organ-grinder's vile instrument ! and hence how beautifully will they supply the loss of the membrana tympani, in those unfortunate individuals who will rush to me in thousands, as soon as they learn how marvellously I can remedy their deficiency ; they obstruct the vibrations so effectually in one instance, that they are sure to conduct them well in the other."

We confess ourselves unable to appreciate the sequence of this line of argument ; we are not poetical enough to give so wide a range to fancy, nor do we admire the philosophy of such drawing-room theories. Many plausible schemes have before now been generated at the fireside, and when com-

mitted to paper have made a very respectable, and even logical appearance ; yet on reducing these same theories by the test of experience, they have been found wanting in one little point, namely, that they are absolutely impracticable. But for this cotton-wool theory we miss even the sole redeeming feature of a pretty theory, unless such exists in a chain of inconsistencies ; for if inconsistencies can add to the completeness and perfection of a theory, then we have one most perfectly constructed, so harmoniously inconsistent that we are led to marvel that so complete a monster could ever fail of success. Beneath the strange forms of those uncouth monsters of antiquity, with the body of a lion, the wings of an eagle, and the head of a man, we are told there existed a hidden meaning, known only to the initiated ; while the vulgar gazed with wonder at the incongruity, the learned smiled and adored. It may be so in this instance ; not being initiated, we may not appreciate the beauties of the "system of plugs."

OTORRHŒA.

Otorrhœa is generally described as the result of accidents, small-pox, measles, scarlatina, scarlet and typhus fevers, scrofula, syphilis, and gonorrhœa : but to be more concise we will here class it as the result of inflammation ; the term may be translated into the language of common life by the phrase, "discharge from the ear."

It needs no very large amount of scientific or medical knowledge to comprehend that this is really a symptom or result of disease, and that it may occur not only in one form of disease but in many. Persons of all ages are subject to it, and it may perhaps be considered as one of the most common phases of aural disease. It may commence with a small degree of moisture in the external ear, and an absence of

pain, so as not to attract any particular attention, and it may finally become increased to a profuse discharge of fœtid matter before medical advice is sought. This course of proceeding is very reprehensible, and there is also much ground for condemnation in the practice adhered to, even in such cases as these, of introducing cotton-wool into the ears, as if to soak up and retain there the fœtid, unpleasant discharge, which nature is endeavouring to get rid of, instead of using the utmost means to cleanse the parts by repeated and gentle syringing and washing ; besides which, it is a dirty and unpardonable procedure to accumulate and preserve this unpleasant odour in so close a proximity to the nose and palate. Cleanliness itself seems to appeal on behalf of common sense and common decency to take the side of reason. That such proceedings really are pursued would to many appear incredible ; but that any medical man should recommend them is harder still to be believed. We have however annexed several cases in point, selected out of many which have come within the range of our experience.

All the causes which are or have been assigned for otorrhœa, as well as an enumeration of all the remedies which have been recommended, would in themselves occupy a very respectable volume : the former might commence with scrofula, and end with cold-bathing, the latter begin with hot oil and roasted figs, and finish with plugs of cotton-wool : the intermediate forms and stages must be imagined. The best piece of general advice we could offer in all such cases is,—throw away such empirical remedies at once and for ever, and keep the ears clean by means of warm water and soap.

Mr. Wilde forcibly describes the consequences of otorrhœa in the following sentence :

“ The ulcerative process may then, or at any previous or subsequent period during the continuance of the discharge,

suddenly and rapidly extend ; the *membrana tympani* is destroyed ; the bony walls of the meatus and the tympanum become carious ; the ossicula are lost, or are rendered incapable of performing their functions ; and the disease spreads into the mastoid cells, and the whole of that process of the temporal bone becomes carious ; fistulous openings occur behind the cartilage, and a thin, brownish, highly-fœtid discharge ensues ; the auricle frequently assumes a bluish, livid appearance ; the motor portion of the seventh pair of nerves becomes affected, or absolute lesion of its substance takes place. The mouth is first observed to be slightly drawn towards the opposite side, and paralysis of one half of the face quickly follows ; the palpebræ remaining apart gives the globe of the eye a peculiarly staring appearance. The cornea, from want of its natural covering and the injurious effects of the atmosphere, abrades and ulcerates ; the *ala nasi* becomes flattened ; the mouth is much distorted (particularly if in a child, when it cries) ; and the whole cheek and side of the face looks fuller. Hearing is in most instances completely lost on that side, and the general health frequently sinks under such accumulated misery ; and even if recovery takes place it is after months of suffering, and always with deformity. At times, and that not unfrequently too, the disease spreads still farther to the petrous bone. The brain and its membranes participate in this unhealthy action ; irritation, fever, rigors, and cerebral symptoms of an insidious nature follow, and delirium, convulsions, coma, and death ensue."

With regard to the treatment of otorrhœa, the condition of the external auditory passage must be ascertained. In the first stage of the disease the *membrana tympani* will be thickened and opaque, and the meatus of a light red colour, with slîmy discharge ; but if the case go on, and become of long

standing, the auditory passage becomes greatly swollen and of a pale yellow colour, the membrana tympani thickened, opaque, and vascular.

In simple otorrhœa, the membrana tympani should be painted three times a week with a solution of nitrate of silver (grs. viiij. to ʒj. of distilled water), and the ear very gently syringed every morning with warm water; in advanced cases, where the membrana tympani is vascular, a leech may be applied to the meatus once a week. Astringent lotions of alum, zinc and lead, will be useful in discharges, when the inflammatory symptoms have subsided. In this disease cleanliness is of the greatest importance, and must be strongly enforced by the surgeon, as the circumstance of allowing the discharge to accumulate is undoubtedly one of the greatest causes of the perpetuation of the affection.

CASE.—W. R., aged 27, applied to the National Ear Institution for relief from deafness in August, 1859. He stated that he had been afflicted for a number of years, and that he was troubled with an offensive discharge, and noises in the head. The deafness came on after a fever. He had no pain, nor did he remember ever having any. On examination the auditory passage was found to be filled with a dirty white ropy discharge, of an extremely foetid smell. On cleansing this away, the membrana tympani was discovered to be thickened, of a greyish colour, and with a small perforation in the middle. He stated that about twelve months since he had consulted a medical man, who told him that he was affected with perforation of the drum of the ear, and advised him to wear a plug of cotton-wool with a piece of thread attached to it in the ear. This, his adviser assured him, was the only way to cure him; the poor fellow wore the wool and thread for some time, according to directions, but

finding to his great discomfort that the symptoms were getting much worse, he again applied to the medical gentleman for advice, and was only recommended to persevere; which he did, until his condition became so bad, that he resolved on seeking other assistance. With this resolution he came to the National Ear Institution: the *cotton-wool and thread* were at once discarded; the ears syringed with warm water, and afterwards the auditory passage and membrana tympani painted with a solution of nitrate of silver. To improve his general health, which was somewhat impaired, a course of alteratives was prescribed, with nutritious diet. After this treatment had been followed for about two months the discharge was perfectly cured, and the hearing was gradually restored. This patient was discharged cured, after being under treatment three months. On examination of the ears some time afterwards, it was discovered that the perforation in the membrana tympani had healed, and the membrane itself assumed a perfectly healthy appearance, and there was a plentiful secretion of wax in the auditory passage.

CASE.—The particulars of the following case are given in the patient's own words, merely omitting the name of the medical practitioner under whose care he had been. "My (Alexander Christie's) loss of hearing was caused by fever, between the age of four and five years, and I have ever since been troubled, more or less, with noises in the head and ears, especially the left; and occasionally with a discharge, which varied in colour and smell. I went on in this way for about twenty years; within the last four years the disease became worse, and the noises, at times, almost unbearable, and the discharge very profuse. Twelve months since, I consulted Mr. ———, who prescribed a box of 'cottons*' and

* We may here explain that this "box of cottons" consisted of a number of small bits of cotton-wool, with pieces of thread attached.

ordered me to use them according to the rules in the prospectus ; namely, to moisten them with hot water, and insert them in the passage of the ear by means of a small tube, and to change them daily. After using them about a month, and my hearing not improving, and the discharge increasing, I went again to Mr. ———, who said that I must persevere in using the cotts, and that nothing else would cure me. After trying them another month, with no improvement, I left them off."

Mr. Christie came under our care in January, 1860. On examination we found the left ear filled with a thick slimy foetid discharge ; after removing which with a syringe and warm water, the skin lining the auditory passage was found of an unnaturally light colour, and so thickened and contracted that it almost formed a perfect stricture, and prevented us from ascertaining the state of the membrana tympani. The right ear was also slightly affected. We painted the passage with a solution of nitrate of silver, and the thickening was soon reduced sufficiently to allow us to examine the membrana tympani, which we found to be of a dirty white colour, much wrinkled and ulcerated in different parts, with a perforation in the centre of sufficient size to enable us to see the handle of the malleus. We applied the nitrate of silver to the membrane and the meatus occasionally ; this, together with constitutional treatment and perfect cleanliness, the discharge never being permitted to accumulate in the slightest degree, perfectly healed the ulcers. We afterwards increased the strength of the solution, which enabled us to reduce the thickened membrane. The hearing gradually improved, the noises became less troublesome, and the discharge ceased altogether. Mr. Christie continued under our treatment till June, 1860, when he considered himself cured, and was discharged.

We may observe that his hearing was perfectly good, but that the perforation of the membrana tympani was not quite cicatrised, although we do not doubt that in course of time it will be so.

These cases speak volumes in themselves, and will argue more potently and effectually than a chapter of logical deductions ; no argument can supersede the argument of facts, a mere enunciation of which is sufficient to compel conviction. The character of the cases which we have just narrated appears to us to be of this palpable nature, and should they fail to convince our readers, we have no hope of being able to adduce further or stronger evidence in support of the views we have enunciated.

CHAPTER VII.

DISEASES OF THE TYMPANUM.

ACUTE INFLAMMATION OF THE LINING MEMBRANE : SYMPTOMS—RESULTS—TREATMENT—CASES, — CHRONIC INFLAMMATION. — CASES. — EUSTACHIAN TUBE : FUNCTIONS—OBSTRUCTION.—ENLARGED TONSILS. — THROAT DEAFNESS.—REMOVAL OF TONSILS.—CATHETERISM. —MANNER OF PASSING THE CATHETER. — INSTRUMENT FOR APPLICATION OF VAPOURS, ETC. —THE OSSICULA AUDITUS.—MASTOID CELLS.—POLYPOID GROWTHS.—MERCURIAL PREPARATIONS. — HYD. C. CRETA.—CALOMEL. — THE BICHLORIDE. — THE BROMURETTED VAPOUR. — ACUTE INFLAMMATION OF THE TYMPANUM.

THE symptoms of this disease are so similar to those of acute inflammation of the membrana tympani, that it would be mere tautology to recapitulate them here ; we will therefore proceed to consider any peculiarity that may exist, and the best mode of treatment.

Acute inflammation of the lining membrane of the tympanum is certainly one of the most painful affections to which mankind is subject. It may be brought on by bathing in cold water, sudden exposure to cold, excess in food and drink, or other causes, which might induce an impure state of the blood ; it is sudden in its seizure, violent in action, and the pain is most intense, extending all over the head and neck.

There is a sensation of swelling in the ear, as if something were there which should be permitted to escape. The deafness becomes very great as the disease proceeds. Tinnitus aurium, varying in character, is also present. The inflammation generally extends to the Eustachian tube, and the mucous membrane of the throat, which becomes of a deep-

red colour with white specks on it. The fauces are tumid, and deglutition causes increase of pain. The pulse is quick, but weak and irregular, the tongue dry, and covered with a thick dark fur, and the bowels constipated, though sometimes diarrhoea sets in followed by great prostration of strength. The membrana tympani is of a dark red colour, that is to say, where the whole of the three layers of the membrane have become implicated. In severe cases the auditory passage becomes much swollen and red; and even the auricle itself sympathises in the inflammatory process going on. The mastoid process is generally very painful, and its condition must be carefully watched during the progress of the disease; if matter form under the periosteum, or the bone itself become implicated in the inflammation, a free incision must be made.

When the disease extends to the internal ear, it will be accompanied with quick jerking pulse, increase of pain in the head, low moaning and mutterings, disturbed intellect and delirium, with dry and hot skin. When the inflammation involves the Eustachian tube, a thickening of the mucous membrane takes place, to a greater or less extent, causing not unfrequently complete stricture. The degree of deafness in these cases will, in a great measure, depend upon four causes; first, the amount of contraction in the Eustachian tube; secondly, the quantity of accumulated mucus in the cavity of the tympanum; thirdly, the extent to which the disease has acted upon the small muscles in the cavity, namely, the stapedius, laxator, and tensor tympani; these muscles often becoming atrophied, and losing their power, so that the functions of the small bones, membrana fenestra ovalis and membrana tympani, become suspended, and the hearing power is lost in proportion to the wasting which has taken place in the muscles; fourthly, the small bones themselves frequently become dislocated, and sometimes the stapes

becomes disconnected from the membrane of the fenestra ovalis ; and again the handle of the malleus may be detached from the membrana tympani. Acute inflammation of the tympanum is sometimes so rapid in its effects, as to cause within a few days, destruction of the membrana tympani, dislocation of the chain of bones (which are discharged from the ear)* ; in addition to which the membrane of the fenestra ovalis is destroyed at the same time, and the fluid of the vestibule lost.

In these cases the surgeon must be very careful not to allow the use of any irritating or stimulating application, as, owing to the entrance to the vestibule through the internal ear being open, insanity, if not death, might be the consequence of the violent inflammatory action which would be set up in the brain.

The treatment of acute inflammation of the tympanum consists in the plentiful application of leeches to the meatus, and mastoid process, and in bringing the system under the influence of mercury, and maintaining its action so long as any inflammatory symptoms remain ; the use of blisters, warm fomentations, the vapours of steam and poultices, may be resorted to according to the requirements of the case. Perforation of the membrana tympani often occurs in this disease, when immediate relief is experienced from the discharge of the pent-up matter.

* In cases where we have had an opportunity of examining the bones after they have been discharged, the inflammation has evidently extended to the bones themselves, and in many instances they have become carious, the destruction commencing on their external surface ; but in reference to necrosis, if the term be employed to signify the death of the bone in the interior, with the formation of new bone on its outer surface, we must confess to have never met with such a case ; perhaps the fact of our not having examined 2,000 dissections, as a certain writer professes to have done, may be thought by some sufficient to account for our not meeting with a case of necrosis of the bones of the tympanum.

CASE.—L. W., aged 36, sent for us in November, 1859, on account of a sudden and most severe attack of pain in both ears. The day previously she had washed her hair in cold water, and before it was perfectly dry had occasion to go some distance. The day was very cold and damp; in the night she awoke with a violent pain in her ears, extending all over her head. She passed a sleepless night in excessive pain and early in the morning we were summoned. On examining the ear, the membrana tympani was found of a dark red colour, and the meatus much swollen; the pulse was quick; the patient experienced great pain in swallowing; the throat was of a deep red colour covered with white spots, and the tonsils were much enlarged and inflamed.

Six leeches were applied to each meatus, and three to the mastoid process, followed by a large soft poultice; calomel combined with opium was administered, until the system was brought under its influence, and a strong solution of nitrate of silver was applied to the throat; in addition to which an alum gargle was ordered to be used three or four times during the day. At the end of the third day the principal symptoms had subsided; on the sixth day she suddenly felt, as she expressed herself, that something had burst in her ear, a sensation which was quickly followed by a discharge, and relief from pain. On examination we found a slight perforation of the membrana tympani, through which mucus was escaping from the tympanum. The ear was gently syringed with warm water daily to keep it very clean, and prevent the accumulation of the discharge, and in a few days all inflammatory symptoms subsided and the perforation in the membrane cicatrised. In this case the hearing was never affected to any appreciable extent.

CASE.—Colonel P., aged 63, summoned us in great haste in March, 1859. On our arrival we found him suffering most

acutely from pain in the ears, head, and neck, which he ascribed to sitting in a draught of air upon the previous night: he complained of great noises in the head, and pain in swallowing. His pulse was quick, tongue covered with dark fur, and he experienced a very unpleasant taste in his mouth. The throat was of a deep red colour, the membrana tympani, meatus, and auricle were all swollen and red; there was great intolerance of light, he was very restless, and his countenance was anxious; his hearing was slightly impaired. Eight leeches were applied to each meatus, and four to the mastoid process, with large soft bread poultices subsequently; ten grains of calomel at bed-time, with a black draught in the morning, were prescribed, and perfect rest in a quiet, darkened room was strictly enjoined. The next day the pain was much subdued, but still severe, and the bowels had not been opened; three leeches were applied to each meatus, and the calomel repeated. Next morning the patient was much better, the bowels were freely opened, the pulse was moderate, the tongue clean, the throat still red and swollen; a strong solution of nitrate of silver was applied to it and blisters behind each ear, whilst a pill composed of calomel half a grain, and opium a quarter of a grain, was administered three times daily. Under this treatment the inflammatory symptoms subsided, and the hearing regained its usual power.

Chronic inflammation of the middle ear is often the result of acute disease, or it may be a manifestation of some constitutional disorder. The observations and rules in reference to chronic inflammation of the membrana tympani are equally applicable to that of the tympanum, and to them we refer our readers. The treatment also is in a great measure precisely similar.

CASE.—In June, 1859, Lady L. consulted us on account of deafness of nine years' duration. She could not ascribe the

affection to any particular cause. On examination we found the external auditory passage dry, smooth, and totally without any appearance of wax. The membrana tympani was white, tense, and thickened : the patient could not inflate the cavity of the tympanum. From our ability to pass the catheter through the Eustachian tube, we ascertained that that passage was open, and we therefore concluded that the cavity of the tympanum was choked up with mucus. The hearing distance on the left side was one and a half inch, on the right three inches. The tonsils were not enlarged, nor was the throat at all implicated in the disease. We prescribed the eighteenth part of a grain of bichloride of mercury in bark, three times a day, and painted the membrana tympani with nitrate of silver in water (gr. xv. to ʒj.), appointing to see her again in a week, when we again applied the nitrate of silver and ordered the mercury to be continued. At the next consultation we found the hearing power increased on the left side to six inches, and on the right to ten inches, at which improvement she expressed herself highly gratified. We now determined to apply the bromuretted vapour to the cavity of the tympanum through the Eustachian tube, in order that we might thus act upon the accumulated mucus. We accordingly applied it for ten minutes daily for a week, at the end of which time she could inflate the cavity of the tympanum on the right side easily, but not on the left. The membrana tympani on the right side was much clearer, and the meatus moist, though no wax appeared : the hearing power on that side was now twenty inches. We continued to apply the nitrate of silver to the left membrana tympani every week, and the mercury was continued in the same doses twice a-day, one hour after breakfast and lunch. She visited us twice a-week to have the vapour applied, with short intervals, for ten weeks. On leaving London in September the hearing power

was about twenty-six inches, and she could join in general conversation with great ease. We had an opportunity of seeing this case in August, 1860, when we found the membrana tympani and meatus perfectly healthy, and the passage well supplied with wax ; the hearing power was about the same.

THE EUSTACHIAN TUBE.

That the Eustachian tube, which forms the means of communication from the throat to the cavity of the tympanum, should be pervious, is a necessity in the healthy exercise of the sense of hearing ; as, if it were obstructed the exhaustion of the air in the tympanum would follow, and the principal function of the tube, namely, the due maintenance of an equilibrium between the air in the tympanum and the external air, for the purpose of preventing too great tension of the membrana tympani, would be lost, and consequent serious defect in the hearing power would necessarily follow. Its other functions, namely, those of supplying the tympanum with air, and discharging the secretions of that cavity, would also cease ; hence the great importance of its being open and free from all obstruction. It is when this passage is closed and great tension of the membrana tympani exists, caused by the absorption of the air in the tympanum, that the operation of perforating the membrana tympani may be beneficial ; but should the tension be owing to contraction of the tensor tympani muscle the operation is useless. The various causes of obstruction of the Eustachian tube are, a collection of mucus, a relaxation of the mucous membrane, and stricture of the osseous and cartilaginous portions of the canal. In rare instances the orifice of the tube may become obliterated.

The most general cause of obstruction is thickening of the mucous membrane, taking place in about the centre of the

tube, or at some point between the centre and the cavity of the tympanum; and may be the result of inflammatory action, either in the throat, or the cavity of the tympanum. It may not be out of place here to refer to enlargement of the tonsils, which is a general accompaniment of inflammation of the throat, and mucous membrane of that part, which morbid action, by its extension from the throat, through the Eustachian tube to the tympanum, may cause considerable deafness; hence the term "throat deafness." Every student, with the slightest knowledge of the anatomy and physiology of these parts, knows perfectly well from the position of the tonsils, that it is impossible for them, however enlarged, under any circumstance to press upon, or interfere with, the orifice of the Eustachian tube; therefore they can have no effect in causing deafness, and Itard never displayed greater ignorance than when he removed the tonsils for the cure of deafness. Mr. Wilde says, "I have never seen nor heard of a preparation showing the greatest possible degree of enlargement of the tonsil, in which it pressed upon the trumpet-mouth of the Eustachian tube. Anatomists will therefore find it as difficult to believe that enlarged tonsils produce deafness, as practical surgeons to believe that their removal can in any way relieve loss of hearing. When deafness coexists with enlarged tonsils, I believe it is produced by the thickening of the mucous membrane extending into the Eustachian tube, or into the tympanum." Kramer says, "I altogether deny the connection of closure of the Eustachian tube with enlargement of the tonsils. I have frequently seen this enlargement both with and without the least dulness of hearing, but always with the Eustachian tubes perfectly free." Harvey says, "that the enlarged tonsil does not give rise to imperfect hearing, that its extirpation does not only not remove deafness, but on some occasions causes it, and that the extirpation of the tonsil

in the young has led to pernicious results, such as bronchial and pulmonary disease." Mr. Toynbee says, "Repeated examinations have convinced me that even should the tonsil enlarge to its greatest possible extent known, it never reaches the Eustachian tube."

Under any circumstances the operation is useless for the cure of deafness. If the morbid state of the throat causing the enlargement be removed, the probability is, that the tonsils will be reduced to their normal size; proper treatment will therefore consist in the application of nitrate of silver, the employment of gargles of alum, zinc and capsicum, inhalation of vapours, and attention to the general health, with the administration of tonics. Should, however, these remedies not succeed, and the tonsils become so enlarged as to occasion difficulty of respiration, an operation will become necessary, and a small portion of the gland must be removed. Lawrence's Tonsil Guillotine we have found the most convenient instrument for this purpose.

Catheterism of the Eustachian tube may be summed up in a few words. Of all the authors who have written upon the subject there is little difference in their description of the operation, their principal object appearing to be, to find *new* language in which to describe it.

The first point to be attended to is the selection of the instrument. It should be in length from about three and a half to six inches, and in calibre about the dimensions of a small-sized pencil, graduating in twelve different sizes. They should be made of silver, and curved at an angle of about twenty degrees, with a dilatation at the end, so as to admit of a small conductor, passing from any apparatus or instrument with which we may be applying air or vapour; with a small ring under the dilatation, to be on an exact line with the curve, not necessarily to secure the instrument, but to

ensure for the operator a knowledge of the correct position of the catheter.* Deleau recommended flexible catheters, and they still appear to be in favour with the French aurists; but one great objection to their use is, the impossibility of passing through them fluids, or vapours where there is great contraction in the Eustachian tube. For supposing that we have passed the instrument with the style in it, directly the style is withdrawn the pressure of the constricted part causes the catheter to close and become a stricture within itself, and therefore prevent, the passage of anything through it. The next object is to place the patient in a suitable position. Many surgeons prefer a chair with a high back, against which the head of the patient rests, and require the body and head to be in a perpendicular position, whilst some secure the head with bandages, straps, and so forth. These proceedings may serve the purpose of impressing upon the patient and friends the idea that a very important and difficult operation is about to be performed, but are of no practical use. Our plan of operation is to have our patient on an ordinary chair, facing the light, to take the catheter between the thumb, index, and middle fingers of the right hand, placing the left on the patient's head to steady it; we then introduce the catheter, having previously warmed it, into the inferior meatus of the nose, its ring and curve being downwards, glide it gently along the floor of the nostril until perfectly clear of the posterior nares; by a gentle curve of the ring outwards the raised surface of the entrance of the tube will be felt, when, with a little careful and dexterous manipulation, the catheter will almost

* In the selection of the size of the catheter for any particular patient, the measurement from the alar cartilage to the antitragus will form the best guide as to length; when catheterism for mere dilatation is required, the calibre of the instrument must be gradually increased, exactly upon the same rule as in the treatment for stricture of the urethra.

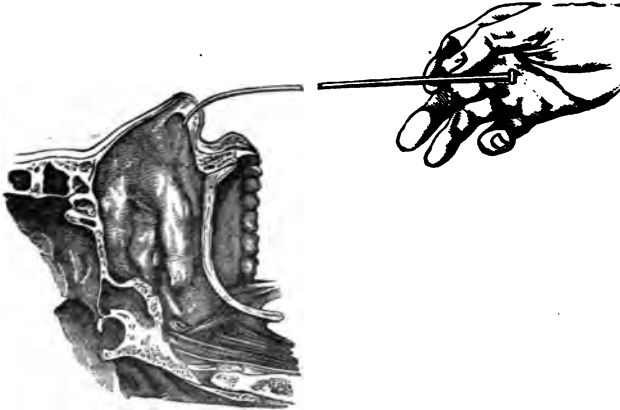
Fig. 17.

Shows the position of the surgeon's hand in introducing the catheter into the patient's nose. The division in the catheter is merely for convenience of illustration.

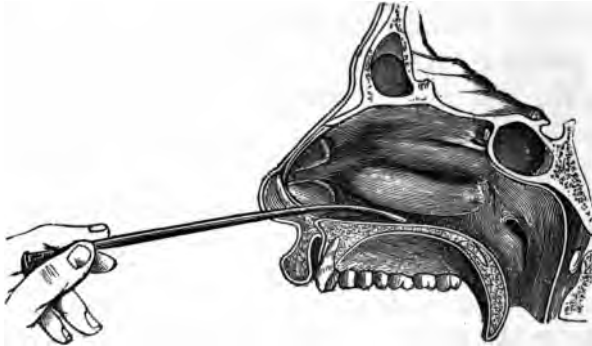
Fig. 18.

Shows the position of the catheter in the middle of the inferior meatus of the nose.

Fig. 19.

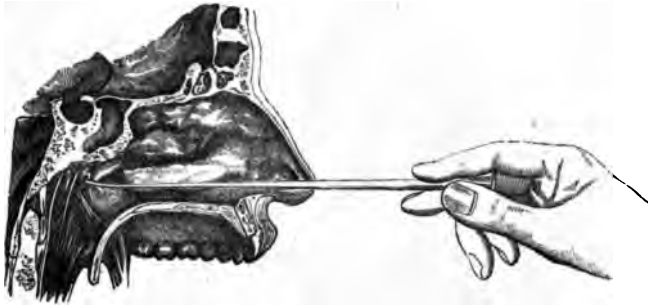

Shows the catheter turned into the Eustachian tube.

Fig. 20.



The instrument in use for the application of vapours, &c., to the tympanum through the Eustachian tube.

Fig. 21.

The instrument in use to the throat.

Fig. 22.

The instrument in use for a tumour on the surface of the body. In this form it can also be used to the external ear.

find its own way into the tube, and consequently leave at liberty the left hand of the operator, which is best employed in steadying the patient's head.

Some surgeons lay great stress upon the end of the nose being raised with the thumb of the left hand, while in the act of operating. We have never found any necessity for this, the alar cartilages being so flexible that they give way to every movement of the instrument. The exploration of the Eustachian tube by the catheter is a valuable means of diagnosis in many aural diseases, and should be resorted to in all cases in which we find our patient unable to inflate the tympanum; unless any actual inflammation is going on either in the Eustachian tubes or any part of the internal ear, which we must subdue prior to the operation.

We have lately been using an instrument for the application of vapours, gases, air, chloroform and fluids to the cavity of the tympanum through the Eustachian tube. It is compact and extremely simple to manage; by it vapour or any other application may be supplied in the desired proportion. The great defect in other instruments for similar purposes has been the impossibility of regulating the force for any given quantity, a defect quite overcome in the apparatus of which we are writing.

Some valuable improvements upon the original instrument have been introduced by Mr. Barker. To Mr. Spencer Wells we are indebted for the suggestion of its adaptation for the application of gases to various internal and external organs of the body, and to Dr. Leared for the suggestion of chloroform; also for many useful hints to Mr. Rogers the analytical chemist.

The instrument is now constructed so that all the applications mentioned above can be used to any organ of the human

body where an instrument can reach ; and through the means of variously shaped glasses constructed by Mr. Barker, it can also be used to tumours on every part of the surface of the body.

The ossicula auditûs may be affected with every form of disease to which bones in other parts of the body are liable ; their muscles and ligaments may also be affected similarly to analogous tissues elsewhere. Inflammation in these bones may lead to their softening, ulceration, and suppuration.

Rigid atrophy of the muscles connected with these bones is a frequent result of inflammation, and causes a complete suspension of the functions of the membrana tympani and membrana fenestræ ovalis ; the chain of bones lose their waving motion, and deafness to a greater or less extent exists. The ligaments connecting these bones are also liable to the same disease. The history of the case, with the condition of the membrana tympani, which will always be found very tense, will be a sufficient guide to the surgeon in making a diagnosis. In all these diseases the use of vapours applied by means of the instrument, *fig. 20*, will be found highly efficacious, in conjunction with constitutional treatment.

Repeated inflammations of the mucous membrane of the tympanum will cause almost complete obliteration of the mastoid cells, in consequence of the great thickening which takes place in the position of that portion of the membrane which lines the cells. Fistulous communications from the mastoid cells externally, are a frequent result of otorrhœa. When neglected the fistulous aperture is generally crowded with fungous growths, and the skin red and irritable. The treatment will be to remove any source of irritation, and to destroy the pseudo-mucous lining by stimulating injections.

When the cavity of the tympanum is in a state of chronic inflammation polypoid growths frequently vegetate upon it.

The bony portion of the tympanum is liable to exostoses formed by irregular hypertrophy, atrophy, abscess, exfoliation, and caries, leading to ulceration and suppuration. The treatment is to remove constitutional disorder and local disease.

There are a few points necessary to be alluded to in reference to the mercurial preparations recommended in this work. It has long been a source of concern that the action of hydrargyrum cum cretâ should be so variable in its effects ; in some cases the action being extremely mild, and in others the reverse. Having been long convinced that this difference proceeded from the preparation itself, which when long made was much more active than when recently triturated, we have for some time discontinued its use. We have, therefore, derived considerable satisfaction in finding that, from the result of the valuable analyses and examinations recently made upon this preparation, we were justified in the course adopted ; it having been clearly demonstrated that hyd. c. cretâ, when recently made by hand trituration, is much more mild in its effects, and more equable, from the smaller amount of binoxide of mercury which it contains, than when made by the aid of machinery, and when kept a long period before its administration. Taking advantage of this examination, we have since ordered, in cases where this preparation of mercury has been used, that it should be of recent manufacture, and made by hand trituration ; but, from a fear lest these instructions should not be fully adhered to, we have deemed it safer to resort to some other and less variable form of mercurial preparation, so as to obviate any uncertainty in its effects. In acute inflammation we prefer calomel combined with opium given at intervals till a slight effect is produced upon the mouth, which should be kept up until all the inflammatory symptoms have subsided. In all cases

salivation, which can only be regarded as a poisonous effect, must be carefully guarded against. There are persons in whom the smallest dose of mercury will induce ptyalism; therefore, in giving it to a patient with whose constitution we are not acquainted, the greatest care should be observed. The best local applications for salivation are gargles of tannin, alum, zinc, sulphuric acid, port wine and water, &c., at the same time keeping the bowels open, and ordering a good diet. In chronic inflammatory affections of the external ear, membrana tympani, tympanum, and internal ear, the bichloride of mercury, extensively recommended in this work, will be found a most valuable agent in removing thickening and effusion, where they have taken place, and in inducing a healthy action in the parts. It may be given, with short intervals, for two, three, or four months together, without any unpleasant consequences, in doses varying from the tenth to the thirtieth part of a grain, administered two or three times a-day, according to the age, sex, and other circumstances of the patient; alone, or with the tinctures of bark, iron, or gentian, or with one of these tinctures combined with rhubarb or aloes. It will also be noticed that we have frequently alluded to the bromuretted vapour, which we have applied extensively with great success to the throat, nose, Eustachian tube, and tympanum, in most cases of deafness in those parts arising from inflammation. Previously, the vapour of iodine, ether, and many other applications of a like nature, had been subjected to a fair trial; but experience has shown that in a properly diluted form, and used with caution, bromine as a vapour is a most valuable remedy in aural surgery.

CHAPTER VIII.

DISEASES OF THE INTERNAL EAR.

INFLAMMATION OF THE INTERNAL EAR. — THE AUDITORY NERVE. —
FACIAL PARALYSIS.—DR. TODD ON PARALYSIS OF THE PORTIO DURA.—
CASES OF FACIAL PARALYSIS WITH DEAFNESS.—ANEURISM OF THE EAR.—
DISEASE OF THE BRAIN.—NON-INFLAMMATORY DISEASE OF THE EAR.—
TREATMENT.

FROM the very complex anatomy of the internal ear, it will naturally occur to the reflecting mind that derangements in it must be extremely difficult both to diagnosis, and treat.

Every portion of the internal ear, namely the vestibule, cochlea, semi-circular canals, meatus auditorius internus, and the parts contained within the several cavities, are subject to inflammatory action, which may be communicated either from the tympanum, or the brain. The important points therefore to consider are the symptoms by which we can diagnose the particular part in which the disease arises—the brain or the middle ear; or again, if the disease arise in the brain, decide upon its particular nature, whether that is inflammatory or non-inflammatory. It is also important that the surgeon should know if the disease arise in any part of the auditory nerve independently of the brain; and in what part of the nerve the disease may be situated, a circumstance that up to the present time has either been overlooked or has baffled writers on aural disease.

Should any derangement take place in this nerve between its root of origin, namely, the fourth ventricle of the brain

and the point at which it separates from the portio dura, we may expect some facial derangement; should there be none, the conclusion may be drawn that the disease is situated between the part of the nerve where it separates from the portio dura, and its point of distribution to the different parts of the ear. The advances made in physiological knowledge in consequence of the discoveries of Dr. Brown-Séguard and M. Flourens, together with well-observed cases, have thrown great light on these intricate subjects; and the deductions which we may consequently derive from these additions to scientific data will materially assist the surgeon in diagnosing a class of aural diseases, which have hitherto been considered so obscure as to be quite out of the range of investigation.

In facial paralysis, should the portio dura (facial nerve) become diseased previously to its separation from the portio mollis, or auditory nerve, aural derangement may be expected at the same time; but according to the best authorities on these subjects, facial paralysis either takes place from pressure or disease of the portio dura, after it has separated from the portio mollis, or defective hearing has never been looked for during the time of the derangement of the facial muscles.

Dr. Todd, in his lectures on the nervous system, states that, "in the vast majority of cases of paralysis of the portio dura it is of little serious import, except from the deformity which it induces, as it is generally due to some disease in its course, or to rheumatic affection, or possibly to conditions similar to those which occur in sensitive nerves producing neuralgia." It is, he says, very rarely the effect of cerebral disease, though it may be the result of intra-cranial pressure, as from the pressure of intra-cranial aneurism; but here the portio mollis will be equally compressed, and hearing on the affected side completely lost, without any other symptoms of disease in the ears.

These important remarks prove, in the first place, that in deafness arising from any defect of the portio mollis, between its origin and the point where it separates from the portio dura, that facial derangement must be expected; and, secondly, that this symptom will enable the surgeon, in cases of facial paralysis, to decide what portion of the portio dura is affected. Dr. Todd states in another part of his work that, "when facial paralysis takes place from disease of the brain, accompanied with a discharge from the ear, especially if it be foetid, it is a serious symptom of mischief extending from the tympanum to the aqueduct."

In such cases the result of our experience has rather been that the disease extended from the tympanum to the vestibule, thence to the filaments of the portio mollis, and so on to the brain, complicating the bone and other structures in its course. Under any circumstances, one thing is clearly proved, that in discharges from the ear, all the muscles supplied by the portio dura should be carefully examined, and if there be any derangement, the brain may be suspected to be implicated.

An interesting case of facial paralysis, accompanied with deafness, recently occurred under the care of Mr. Lawrence, at St. Bartholomew's Hospital. A child in good general health, about five years of age, was admitted into the hospital to undergo treatment for deafness, and complete paralysis of the muscles supplied by the portio dura on both sides, with discharge from both ears. He was quite deaf, and no history of his case was obtained from his friends. The paralysis, however, followed some exanthem for which he had been treated at the Fever Hospital. When asleep, his eyes were half open, and looked straight forward. He could not move his mouth at all, and his speech was imperfect; he was able to move his head freely. This case was diagnosed as

disease of the temporal bone, but the correctness of the diagnosis could not be fully established, as the child left the hospital before the result of the case was known. The following case occurred in our own practice.

P. S., aged 22, was placed under our treatment for deafness attended with profuse discharge of a highly foetid nature from both ears. The membrana tympani was entirely destroyed, and the ossicula discharged. The Eustachian tube was pervious, but so sensitive that we did not attempt, after the first visit, to pass the catheter. The patient had a quick, jerking pulse; tinnitus aurium was present; the bowels were very costive, the pupils dilated, and the countenance presented a wild, haggard expression. All the muscles of the facial nerve were affected, the distortion was at times frightful, and it was evident that the brain was seriously implicated. The pain in the head was constant and severe. The treatment adopted was directed to lessen his sufferings during the short remaining period of his life, for it was very evident that nature was sinking fast. He died in convulsions one week after our first seeing him. By the kind permission of his friends, a post-mortem examination was obtained. There was great vascularity of the dura mater, which was ulcerated; the arachnoid was thickened and bathed in a quantity of serous fluid, and all the nerves at their origin were enveloped with purulent matter; the facial and auditory nerves being almost in a state of suppuration. The extremity of the petrous portion of the temporal bone was carious. The vestibule, cochlea, and semi-circular canals were full of foetid pus. The ossicula auditûs were absent, and the membrana tympani, the membrana fenestræ ovalis, and the membrana fenestræ rotundæ, destroyed. The mastoid cells were carious and contained purulent matter. The disease in this case obviously arose in the tympanum, and was communicated

thence to the internal ear; while the one previously cited bears every appearance of the disease commencing in the brain itself.

J. E., aged ten years, was brought under our notice for a case of deafness in the right ear. On examination we found every part of the ear perfectly sound, the Eustachian tube pervious, and so far as we could judge the cavity of the tympanum healthy; he experienced no pain, but complained very much of a noise in the ear. The boy was under our treatment three months, without the slightest improvement taking place, when we lost sight of him. Twelve months afterwards we were called to the same boy, who was suffering from disease of the heart, and died a fortnight after our seeing him the second time. Not being able to diagnose satisfactorily the cause of his deafness, we were anxious to obtain a post-mortem examination, which his parents allowed; we then found an aneurism of the auricular branch of the basilar artery, in the meatus auditorius internus, causing such a pressure upon the nerve as to completely suspend its functions. The nerve was perfectly healthy in every other part of its course. His death, we may observe, was caused by the disease of the heart just before mentioned, not by the aneurism.

We have lately had an opportunity at a post-mortem examination of inspecting a case of total deafness, where the disease was communicated from the tympanum to the vestibule, and from thence to the filaments of the auditory nerve, every other part of the nerve being healthy. The subject, a boy aged thirteen, was killed by an accident which occurred in consequence of his deafness. This case is one which illustrates that if the filaments of the nerve lose their functions, the loss of hearing power is equal to that occasioned where the nerve itself is destroyed.

The following case came under our notice in January, 1859:—

E. H., at the age of 17, received rather a severe blow on the head, which caused, however, no apparent injury, nor did it at the time receive any particular attention. From that period she gradually became deaf; she never suffered from pain in the ears nor head, except such as might arise during any temporary constitutional disorder; but she was of a delicate and nervous temperament, and much depressed on account of her deafness. Five days previously to our being called in, she was suddenly taken very ill, with vomitings accompanied with shivering, followed with hot sweats, but no head-ache. The medical gentleman in attendance treated the case as one of slight derangement, till the fifth day, on which she became alarmingly worse, quite deaf, convulsed, and insensible, with a hot skin and quick pulse. Ice was applied to the head, mustard poultices to the feet, and blisters to the back of the neck; but the convulsions succeeded one another rapidly, and death closed the scene on the following day, one week after the commencement of her illness, and ten years after her receiving the blow on the head.

Post-mortem Examination.—Slight effusion was found on the surface of the brain, a small abscess on the floor of the fourth ventricle, at the origin of the seventh pair of nerves; the pressure from this abscess upon the nerve was very great. At their origin these nerves were exceedingly soft and pulpy, more especially the facial, which is a very unusual occurrence. There was no appearance of irritation in the membranes, and the nerves were perfectly healthy in every other part of their course. No symptoms of disease existed in the middle or external ear. We attributed her death to pressure caused by the abscess upon the substance of the brain.

It will be observed that in this case there was no particular

pain, nor any symptom of irritation discovered at the post-mortem examination in any part of the membrane. This would agree with the observations arrived at by Dr. Brown-Séquard and M. Flourens, that pressure may exist on any part of the brain, and to any extent without pain, so long as that pressure is not attended with irritation; and that such pressure may cause a complete suspension of the functions of any of the sensory nerves, and hence of the organ which it supplies, without any other symptoms than merely the loss of function in that particular organ from which the nerve is destined to receive the impression.

In inflammatory diseases of the ear extending to the brain, perfect rest of mind and body must be enforced; cold applications, or evaporating lotions to the head, calomel and purgatives in repeated doses, and a low diet, with bleeding from the mastoid regions, nape of the neck, or occasionally the temples, will be the treatment required; when the violence of the symptoms have abated, a course of gentle alteratives, mercurials, counter-irritation, change of air, and regular nutritious diet are indicated; if the patient be low and feeble, stimulants and tonics are required.

Non-inflammatory diseases of the internal ear, in which, without any apparent cause, the deafness gradually creeps on and increases; with, or more generally, especially in advanced cases, without tinnitus aurium; or in which the affection can be plainly traced to some mental affliction, shock, and great grief, or to a too great exertion or strain on the mind, and in which no morbid condition of the ear can be traced, except perhaps a collapse and opacity of the membrana tympani, and total absence of the cerumen,—to these cases we may correctly apply the term “nervous deafness.” The result of our experience teaches us that such cases are fortunately exceedingly rare, and that the term is too frequently used as

a cover for ignorance; but even in such cases, where the patient is fortunate enough to seek and obtain good medical advice in the first stage of the disease, much may be done; if, on the other hand, of long standing, they are generally hopeless, and all we can do is to improve and strengthen the health of our patient by every means in our power. Change of scene and air should be indulged in whenever practicable, and the attention should be as often as possible rivetted upon some favourite employment, gratifying amusement, or healthy business; cheerfulness is essential to a healthy condition of the body; and everything which tends to depression, deranges the respiration and mars the proper oxygenation of the blood; when, then, there exists a continual sense of hopelessness, distressing reflections on the deprivation of which they are the subjects, the deaf prepare the path for other maladies, whilst they strengthen the influence of that which afflicts them.

CHAPTER IX.

MEDICAL ELECTRICITY.

NEGLECT OF ELECTRO THERAPEUTICS.—ELECTRICITY NOT A “SPECIFIC.”—APPLICATION IN DISEASE. —“NEW CURES.”—APPARATUS TO BE EMPLOYED. —AUTHOR’S IMPROVEMENTS IN MAGNETO ELECTRIC BATTERY.—APPLICATION TO INTERNAL ORGANS.—POWER OF CURRENT OBTAINED.—CONTROL OVER CURRENT.—AUTHOR’S INSTRUMENTS FOR INTERNAL ORGANS.—ACUTE INFLAMMATION OF EXTERNAL AND MIDDLE EAR.—THROAT.—NOSE.—CONDITION OF MEMBRANA TYMPANI.—LOSS OF MUSCULAR POWER.—DEFICIENCY OF NERVE SUPPLY.—NEURALGIA OF EAR.—NERVE PAINS, TREATMENT, RESULTS OBTAINED BY ELECTRICITY.—METHOD ADOPTED.—CASES.—PERSISTENCE REQUIRED.—DISEASES IN WHICH BENEFICIAL.—MEDICAL OPINIONS.—ELECTRO-PUNCTURE.—CONCLUSION.

THAT Electro Therapeutics have not been more generally studied by medical men may be traced to a variety of causes, and in consequence, the use of electricity in disease has till recently been almost exclusively confined to the hands of empirical adventurers, totally ignorant of anatomy, physiology, medicine, and of the electric current, and its proper mode of application in disease. This state of things is however fast passing away, surgeons of eminence, both in Europe and America are devoting their attention to the subject with extremely beneficial results in many diseases hitherto deemed incurable. The value of this interesting science in medicine and surgery is not yet however sufficiently understood to warrant us in pronouncing positively as to the accuracy of any particular theory; but to administer it with any success, we may say a thorough knowledge of anatomy and physiology is indispensable.

The folly of imputing to any one mode of treatment the

power of curing all disease is now, even amongst the most ignorant, generally acknowledged; we do not offer electricity as a "specific," there can be no such thing, the only one known or ever likely to be known is that which terminates all earthly sorrows, all human pain—the hand of Death. Our aim in the treatment of disease by electricity is to follow well established scientific, medical, and surgical treatment, applicable to the innumerable complaints to which flesh is heir; and we use this agent as a most valuable assistant in conjunction with other methods of treatment. Our patients frequently ask us if we have discovered any "new cure"; we do not profess to invent or introduce wonderful remedies, we lay no claim to infallibility; unascertained and unthought-of disease in a region other than that under our immediate attention may, just when we think we are at the point of success, defeat our hopes; and daily the physician and surgeon are brought face to face with the knowledge that, notwithstanding all our brilliant discoveries, medical science still has its circumscribed bounds.

An all important point in the application of electricity in disease, is to determine the strength of the battery to be employed, as its successful use can only be ensured by the selection of an instrument that admits of the thorough regulation of this powerful agent. We prefer not to recommend any particular battery, but advise patients to consult any leading electro-therapeutist upon the particular one to be selected, who, taking a true and comprehensive view of their symptoms will be enabled to recommend the instrument best adapted for use in their particular disease.

We have succeeded in introducing some improvements into the Magneto Electro Machine, rendering it applicable to nearly all medical purposes when properly and judiciously handled; from these improved batteries we can obtain the mildest

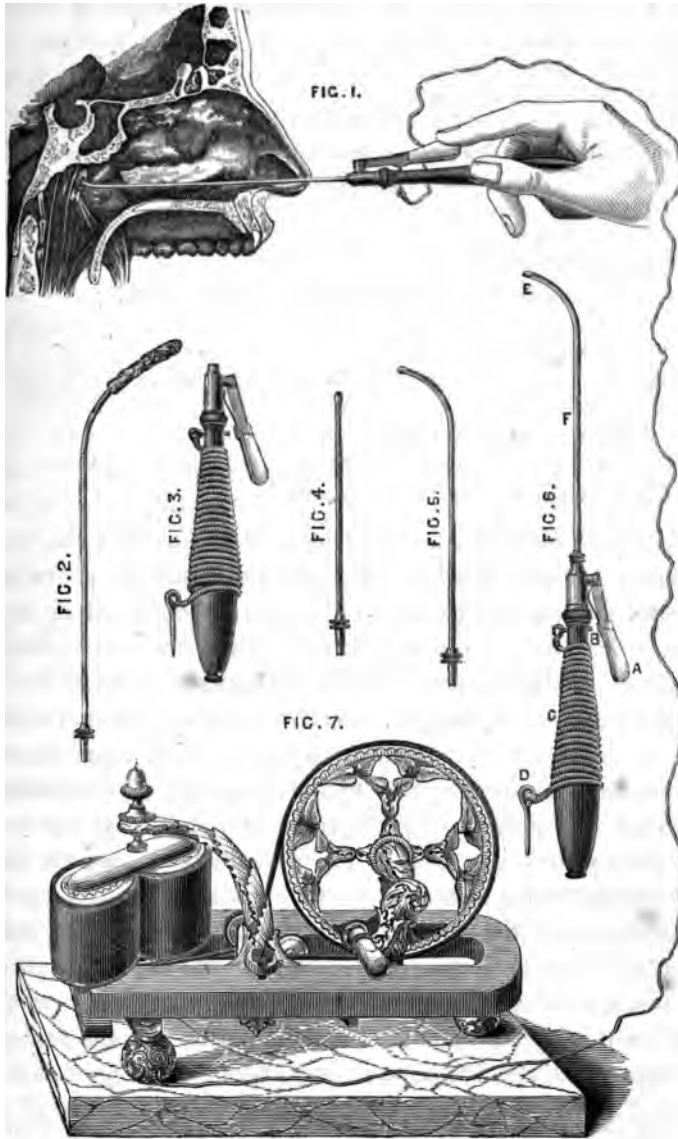

Fig. 1.—The operator applying the Electro Catheter to the Middle Ear through the Eustachian Tube.

Fig. 2.—The Throat Conductor (detached).

Fig. 3.—The Handle (detached).

Fig. 4.—The Electro Conductor for the external surface of the membrana tympani, and for the meatus auditorius externus (detached).

Fig. 5.—The Electro Eustachian Catheter (detached).

Fig. 6.—The same attached to handle ready for use.

Fig. 7.—The Battery.

A.—Small lever on handle.

B.—Point of attachment of the metals when the lever is pressed.

C.—The handle with conducting wire.

D.—Pin for attachment to the battery.

E.—Extreme point of catheter, showing the conducting medium emerging from the insulated tube.

F.—Insulated portion of the Catheter.

G.—Vertical section of the head, showing the inferior meatus of the nose.

H.—The Catheter turned into the Eustachian Tube.

current necessary for use to the internal organs, and the most powerful current required in obstinate cases of neuralgia, sciatica, and similar diseases; the current obtained is very regular and uniform, pleasant to the patient, and can be varied to suit different constitutions with the utmost exactness.* To avoid all danger in applying electricity to any internal organ it is requisite for the operator to have a perfect and instantaneous control over the current, independently of the battery. The author's instruments represented in *figs. 2. 4. 5.* are constructed to meet this want. These conductors each fit into one handle which contains a small spring giving complete command over the current (See *fig. 3.*). Being designed for internal organs they are well insulated with the exception of the point, so that the current is directed immediately to the spot we wish to act upon; the various portions of the passage through which the instrument goes, being entirely protected

* This machine is portable, cheap, and easily managed, and with care will last a life time.

from the action of the current. *Fig. 6.* is the Electro Eustachian Catheter, to apply the electric current to the cavity of the tympanum. *Fig. 4* is the Electro Conductor for the external surface of the membrana tympani, and the meatus auditorius externus. *Fig. 2* is the Electro Conductor for the throat.

These three Conductors are all that are required for the application of electricity in cases of deafness, and are adapted to use with any battery ; the author has carried out the same principle in conductors for the rectum, bladder, and uterus. See *Figs. 3, 4, 6.*

After cases of acute inflammation of the various portions of the external and middle ear, or of the throat, nose, or any part of the mucous membrane which extends into the middle ear, when the parts attacked are left, after the inflammation has subsided, in a weak and irritable condition, the external auditory passage dry, with perhaps total absence of wax, the membrana tympani thickened and almost insensible to the touch, the tinnitus aurium very distressing, and the general health deranged, with great loss of muscular power, especially of the membrana tympani or any of the small muscles attached to the auricular chain of bones in the cavity of the tympanum, this deficiency being generally due to a want of nerve supply to these particular parts ; electricity applied daily, combined with the treatment recommended in other portions of this work in cases of chronic inflammation, we have found very efficacious. In cases of neuralgia of the ear, and all other nerve pains, we have used it with gratifying results in combination with tonics and constitutional treatment, also in cases of functional nervous deafness where there was some disease of the auditory nerve, or brain, with general torpor and debility, and more or less impairment of hearing power.

From the results obtained we have lately been encouraged

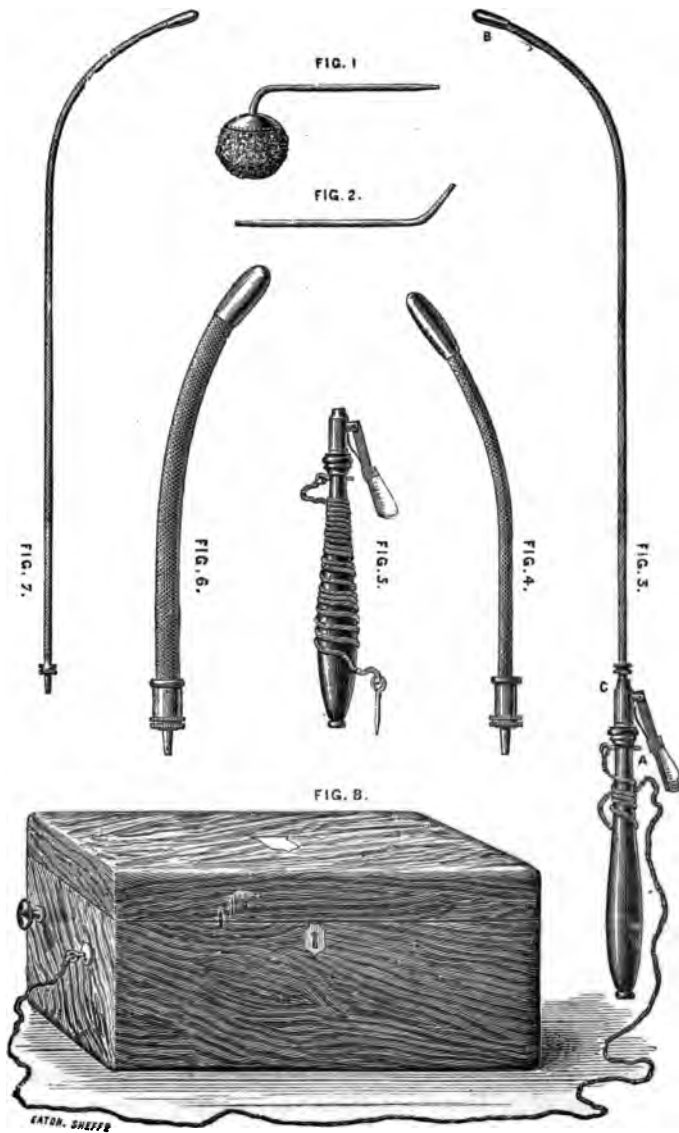

Fig. 1.—Sponge for external use.

Fig. 2.—Conductor for dental purposes.

Fig. 3.—Electro Catheter for the bladder.

A.—The Spring and Lever to connect the electricity.

C.—The point of attachment of the Catheter with the handle.

B.—The Conducting Medium, emerging from the insulated tube.

Fig. 4.—Conductor for the Rectum (detached).

Fig. 5.—The Handle (detached).

Fig. 6.—Conductor for the Uterus (detached).

Fig. 7.—Catheter (detached).

Fig. 8.—The Battery.

to use the electrical treatment very extensively in our aural practice, especially in cases in which the symptoms were similar to those described above, many being of old standing and not amenable to other remedies. The following was our mode of treatment :—

External application of the current to the facial nerve and over the mastoid process ; internal application to the outer surface of the membrana tympani, and to the throat and larynx, also a very mild and careful current sent through the electro catheter *fig. 6.* to the cavity of the tympanum, * our object being to act upon the internal surface of the membrana tympani, and the muscles connected with the auricular chain of bones, also upon the membranes of the fenestra ovalis and fenestra rotunda, and through these means upon the filaments of the auditory nerve. We will now proceed to relate the particulars of a few cases, selected from the many we have lately had an opportunity of treating by the aid of electricity. To explain our method of applying the current it will be only necessary to illustrate two or three cases, the electric treatment being very uniform.

G. T. aged 78, applied to us in February, 1873, for extreme

* In employing this treatment to such delicate parts, the utmost care and every precaution is necessary ; the operator should be a perfect master of Catheterism, and have an intimate knowledge of diseases of the internal ear and brain.

deafness of 25 years duration. He stated that he had not heard the clock strike for that lengthened period. On examination the external auditory passage was found to be white and dry, without any appearance of wax, and the membrana tympani of a dirty white colour, thickened, and having the appearance of crumpled parchment; so great was the thickening of the membrane that it might almost have been considered a distinct growth; throat red, tonsils enlarged, could only hear the tick of the watch when pressed to the side of the face. We applied a solution of nitrate of silver to the membrana tympani gradually increasing the strength of the solution, and a preparation of iodine to the tonsils, continuing this treatment for three weeks: the membrana tympani assumed a more healthy appearance, and the thickening was reduced, but the membrane gave no signs of vibration, and the hearing power did not increase. We now commenced the electrical treatment, applying a moderate current to the front of the auricle, and to the mastoid process, also to the external surface of the membrana tympani, a perceptible improvement in the hearing power marking each application; at the end of two weeks, we sent a mild current into the cavity of the tympanum, and also to the throat; the treatment was continued for five weeks and the hearing power regained to the extent of twenty two inches distance on the right side, and eighteen on the left.*

A Lady aged 45, consulted us in November, 1872, for deafness of 15 years' duration. On examination we found the state of the external auditory canal and membrana tympani normal, throat red and relaxed, constitution highly nervous and excitable, tinnitus aurium very distressing, Eustachian

* We conclude in this case that the membrana tympani had lost its muscular power, and that the muscles attached to the auricular chain of bones in the tympanum had become rigid, and their functions suspended.

tube inflatable, hearing distance half-an-inch. We applied electricity to the throat and external ear for one week, with very slight improvement; we then commenced to pass a mild current into the cavity of the tympanum, the first three applications causing headache and considerable fear and anxiety; these symptoms however quickly passing away, and finding the hearing power increased to two inches, and no constitutional disturbance, we decided to proceed with the treatment. The fourth application occasioned no pain, our patient being afterwards in very good spirits, and very lively, her previous state of nervous excitability being almost entirely subdued. The treatment was persevered in with short intervals for seven weeks, at the end of which time the hearing power was increased to the extent of hearing the tick of our watch 30 inches distant on each side.

M. C., a male, aged 45, applied to us in December, 1872, on account of deafness in both ears of twelve years' duration. Upon examination we found the external meatus and auditory passage dry, white, and polished, the membrana tympani partially thickened and opaque, the Eustachian tube uninflatable, no pain, throat normal, very distressing noises in the head, health good, hearing distance half an inch; right and left ear similarly affected; attributed the disease to cold in the first instance. We painted the membrana tympani daily with a solution of nitrate of silver to reduce the thickening, and injected air into the tympanum through the Eustachian tube to remove the obstruction; continuing this treatment for one week without any improvement in the hearing power, we now commenced the application of a mild current of electricity to the membrana tympani by our Electro Conductor, *fig. 4*, and behind the ear, over the mastoid process for ten days, for five minutes each day; on the eleventh day we passed the Electro Catheter, *fig. 6*, into the Eustachian tube, and for half

a minute applied a very gentle current into the cavity of the tympanum. A cure was effected in twenty applications.

The length of time required for a course of electric treatment depends greatly upon the constitution and temperament of the patient, and the nature and condition of the complaint. In obstinate cases we have found that the electrification required to be repeated for a lengthened period, in some instances several months, to obtain a perfect recovery, though in others a decided benefit was experienced after a few operations. In the majority of cases the improvement is very gradual and almost imperceptible to the patient, on this account it is desirable for the operator to make notes of each case from day to day, carefully recording the effects produced.*

In a work devoted to Aural Surgery it would be out of place, and indeed, in the space at our disposal, impossible to specify the many diseases in which electricity is beneficial, but in all cases of defective circulation and nerve supply, in atrophy, paralysis, deficient menstruation, lateral curvature of the spine in the young, palsy of the bladder, many diseases incident to women, in constipation and torpor of the bowels, incontinence of urine, we may with constitutional treatment resort with every prospect of benefit to this powerful remedy. The late Sir James Simpson, and Professor Christison, speak very favourably of its use in many internal diseases; Dr. James Finlayson relates in the *Glasgow Medical Journal* for November, four cases of facial paralysis cured by electrical treatment; Dr. Goulding Bird says "its application in disease is of far greater importance than has hitherto been considered;" Dr. Von Kraft Ebelin, an eminent German physician says "No case should be dismissed as incurable before the galvanic current has been employed, more so as the application of this reme-

* The Esthesiometer introduced by Dr. Sievking is useful in diagnosing nervous diseases, and the progress of cases under electric treatment.

dial agent can do no possible harm." M. Becquerral strongly recommends the use of powerful currents in neuralgia, furnishing statistics which show that nineteen cases of sciatica, and twenty three of neuralgia, many of old standing, were perfectly cured by the judicious use of powerful electric currents. The author has found in his practice the use of the electro-puncture highly beneficial in obstinate neuralgia, inserting the needles deeply at two points in the course of the nerve.

In conclusion, we confess ourselves at some loss to what cause to impute the fact that so little has been done to diffuse a general knowledge of the diseases to which humanity is prone. In an age when so much is being accomplished for the diffusion of knowledge on almost every other subject, there is evidently some cause for surprise that so little has been attempted in this direction. It might be suggested that those who are able to present such works to the public in an attractive form, and yet withal correct in their details, and useful in their ultimate results, consider it a little below the dignity of their vocation, or beyond the legitimate scope of their profession; or it may be, that there still remains in them a small amount of that old conservative spirit, (which, by the by, can scarce be the true spirit of conservatism,) which fears the extension of knowledge, or dreads the consequence of science made popular. This is, at the least, but to create a monster after the fashion of Frankenstein, and to be alarmed at its shadow. Whatever may be the cause, the fact still remains; and whilst the study of chemistry is becoming daily more diffused, anatomy and physiology, the laws of health and disease are forgotten, at the same time as the line of the poet—

“The proper study of mankind is man.”

There cannot be a doubt that medical men are the persons best qualified to make the public acquainted with these

subjects ; but they appear to look at the work with fear and trembling, lest in its performance they should be deemed empirics and charlatans. A little reflection would serve to convince them that their fears are groundless, and that they leave a *duty* unperformed in not taking the task out of the hands of those less fitted to render it the justice it deserves. There are many vulgar errors to be exploded, many wrong notions to be set right, and there is much room left for sound instruction, which in the end will not diminish the need of medical men, nor decrease the limits of their practice. On the contrary, a correct appreciation of the dangers of delay, and a ready recognition of the early stages of disease, will send sufferers sooner in search of good medical advice, than while under the spell of ignorance, when slight indispositions are ascribed to all imaginable causes but the right, and the most absurd steps are taken to abate maladies which have no existence save in imagination and the fabulous history of the past. Not that we intend to advocate the publication of a series of handbooks on domestic medicine, or to recommend how one reader may physic his friend, or operate upon his neighbour ; but rather that he may understand, appreciate, and respect the house in which his spirit dwells, and know when it is getting out of order ; the consequences liable to ensue ; and how he may preserve himself from such forms of disease as may result from either ignorance or carelessness. How often do we meet with cases in which we are compelled to give expression to our regret, that the patient had not earlier become sensible of the encroachments of disease? How often have we to say, Why did you so long defer an application for medical advice, and allow your disease to gain so firm a hold upon you? Such remarks are common enough, and much more common than they would be if a better knowledge of the laws of health were more widely diffused. We rejoice

that general attention is being directed to these subjects as being in every sense worthy of forming a portion of the elementary instruction to be imparted to our children in the public schools; and when steps are in progress to organise systematic instruction on these points for children, it seems an anomaly that those who have grown up without obtaining such a knowledge, should be forgotten, and no steps taken to remedy the deficiency.

It may be argued, and with much consistency, that this is the only true means whereby the army of charlatans in medicine will be defeated. Diseases are not as formerly so much imputed to the influences of the heavenly bodies, nor is their cure supposed to depend upon the movements of the planets; yet errors equally superstitious, if not equally gross, are daily committed. We might refer to some of the malpractices in connection with diseases of the ear to which reference has been made in the foregoing pages, in confirmation of this statement; and indeed there is scarce a form of disease which has not its popular form of treatment, based more or less on some traditional success, honoured perhaps in its antiquity, but which would be much more "honoured in the breach than the observance." The belief in panaceas and "pathies" of all kinds will vanish before the spread of an enlightened knowledge of physiology and the unchangeable laws which govern health and disease.

THE END.



OPINIONS OF THE PRESS
UPON THE
FIRST EDITION
OF THE
DIAGNOSTICS OF AURAL DISEASE.



“Mr. Smith is the most practical Aural Surgeon of the day, and his book is the best which has been written on diseases of the Ear.”—*London Medical Review*.

“Mr. Smith is the most expert operator of any known Aural Surgeon.”—*American Medical Times*.

“Mr. Smith gives striking illustrations of the great power he possesses in the treatment of cases of deafness, more particularly cases in which the speech has become defective in consequence of the loss of hearing power.”—*Edinburgh Review*.

“We have regarded with satisfaction the figures of the instruments Mr. Smith has invented for use in cases of Polypi or extraction of morbid growths. They are delicate, simple and portable, and likely to prove of great service in aural surgery.”—*Exeter Flying Post*.

“Mr. Smith is a most expert operator, and has written extensively on aural disease . . . a little boy five years of age, the grandson of Mr. D——, Newcastle, whose hearing had been nearly lost in the left ear, in consequence of a large morbid growth on the membrana tympani, was last week successfully operated upon by Mr. Smith, who skilfully removed the polypus, which was about the size of a small cherry and of a deep red colour, and attached to the membrana tympani; the child can now hear a whisper, and has experienced no pain or inconvenience since the operation.”—*Newcastle Express*.

“Mr. Smith's position and success as an aurist have been known to us for a number of years, and in the north of England several remarkable cases of cure have come under our observation, amongst which we may mention that he has succeeded in restoring the hearing of one of our leading local clergymen.”—*Middlesborough Evening Gazette*.

“Mr. Smith has devoted his entire attention to diseases of the ear, and has had the advantage of extensive practice. He is also the inventor of some very valuable instruments; and the new method of treating diseases of the middle ear, (hitherto considered incurable) was introduced by him.”—*Newcastle Daily Journal*.

“Mr. Smith has acquired considerable repute in the branch of surgical practice that pertains to the ear, and its abnormal conditions. After devoting preliminary

chapters to the nature of sound, the anatomy and physiology of the ear; he treats of the different aural diseases, giving in each instance the symptoms and treatment. Mr. Smith has introduced and brought into notice a method of applying gases vapours, and chloroform to various organs in the human body, and of treating diseases of the internal ear through the Eustachian tube by these powerful remedies. In this work are given illustrations of the instruments used, and numerous cases are adduced."—*Hull Eastern Morning News*.

"Mr. Smith has paid considerable attention to his subject, he has written numerous treatises upon the ear, and acquired no small reputation by his lectures thereon in London, and elsewhere. For some time he was connected with the National Ear Institution, London, therefore possesses large experience. He is the inventor of an instrument for the application of gases and vapours to the human body, proving that he is not simply theoretical, but practical in his aims."—*Exeter and Plymouth Gazette*.

"We recommend the work to our readers as the production of the most successful and practical aurist of the present day. It is published by Mr. Bailliere the eminent scientific publisher."—*Rugby Advertiser*.

"This is a good and practical treatise on the diseases of the ear, and the author has spared no pains to deal with his subject in such a manner as will lead medical and other men to the more careful study of the treatment of a malady that deserves universal commiseration."—*Somerset County Gazette*.

"The book is nicely illustrated with several wood cuts, showing the external, middle, and internal ear, the author's Speculum, and Illuminator, also the passing of the Catheter into the Eustachian Tubes. We would advise all who are afflicted with deafness to purchase the book, and consult the eminent author."—*Devon Times*.

"This is a most able work upon the ear and the diseases to which it is liable, written by a gentleman of extensive practical experience in its treatment."—*Hull Packet*.

"Mr. Smith describes the structure of the ear very minutely, externally and internally, and shows the functions each department has to perform. The principal causes of deafness are set forth, and there is an interesting chapter on Polypi, with the course pursued by the author in his treatment of the different aspects under which the polypus appears, and numerous instances are given of the successful treatment of cases both in his private practice, and at the National Ear Institution."—*Hull Times*.

"This is one of the most complete and interesting works of the kind we have ever met with, and supplies a great amount of information upon the subject of which it treats."—*Hull News*.

"Mr. Smith's high reputation as one of the first aurists of the day led us to expect a very superior work on the subject to which he has so long and successfully devoted his talents, and in this we were not disappointed, the subject being so ably and lucidly treated by this master of his profession, that not a page but contains matter to interest even ordinary readers, while professional men acknowledge it to be one of the most compact manuals of the ear and its diseases ever published."—*Belfast Newsletter*.

"Mr. Smith commences with a chapter on sound, giving in an interesting manner the conducting medium of nearly all the earthly bodies, followed by a clear and concise description of the anatomy and physiology of the ear, . . . diseases of the ear claim our author's next attention, and are treated of at great length. In this portion of his work Mr. Smith makes no mystery, he feels himself a master of his subject, and can consequently afford to be perfectly liberal in the teaching of his own particular views."—*Elgin Courant*.

"Not only is Mr. Smith well acquainted with the matter on which he writes, but his practice has been most successful, resulting in cures in very obstinate cases."
—*The Western Argus*.

"The author has evidently carefully studied the ear both anatomically and physiologically, and having had extensive experience in the treatment of aural disease, is well qualified to write such a work. The name of the publisher is a guarantee in itself, and we observe the London medical press speak of it in high terms. We may add it is well got up and illustrated."—*Dumbarton Herald*.

"If we may judge from the frequency of its defects, the ear must be as delicate as it is wonderful. There must be enough in that wonderfully formed organ to engage the life-long study of any man who aspires to treat efficiently the various ailments incident to it. The author of this book has obviously given a large amount of study to the subject of deafness, and diseases of the ear; we have read his descriptions of the anatomy and physiology of the ear with interest, . . . he evinces a thorough acquaintance with the diseases to which it is liable together with the most enlightened methods of treatment, illustrated with a variety of cases gathered from his own practice."—*Glasgow Evening Citizen*.

"This work contains a great amount of information on the ear and aural disease. Mr. Smith has given the subject a great deal of study, and has acquired an amount of knowledge regarding it which enables him to treat diseases of the ear with immense success. The best proof of this is to be found in the many cures which he has been enabled to effect on persons on whom medical skill had hitherto been unavailing."—*Christian News*.

"This is a beautifully illustrated medical work giving an elaborate account of the diseases of the ear; while of a strictly scientific nature, it conveys a large amount of practical information, in an attractive form. Mr. Smith is considered to be the most practical aural surgeon of the day, and is well qualified to afford valuable instruction and advice on the subject of which his book treats."—*Hamilton Advertiser*.

"Formidable as the title looks, no unprofessional reader need be afraid to undertake the perusal of the book, . . . it is just such a one as may be safely put into the hands of any of those unfortunately compelled to take a personal interest in the subject of deafness, . . . in clearness, plainness, compactness, and excellence of pictorial illustration, there is about it little left to be desired."—*Glasgow Morning Journal*.

"The author takes up his subject in a strictly scientific spirit . . . Discusses what science has attempted for the cure of aural disease, and what real surgical skill may be expected to do, . . . He gives somewhat in detail the particulars of the successful use of bromuretted vapour in the treatment of various diseases of the ear, with a description of a very beautiful and delicate instrument invented by himself for the application of this and other vapours to the internal parts of the ear."—*Aberdeen Free Press*.

"Mr. Smith has acquired high reputation in connection with aural practice; in the work before us he devotes 108 pages to describing the anatomy and physiology of the organ of hearing, and the most cursory reader will not fail to see he is master of the subject."—*Invergordon Times*.

"Mr. Smith's scientific judgment as a first-class aural surgeon is best proved by the result of the difficult cases placed under his care. The case of Mrs. C——, Chepstow, is very interesting: after being deaf for the long period of 52 years, to have regained her hearing, is certainly a remarkable testimony to the efficacy of Mr. Smith's treatment."—*Swansea Journal*.

"Mr. Smith has given particular attention to the study of the ear and its diseases, and while his treatise handles briefly, but intelligibly, the subject of sound

in relation to the ear, the anatomy, the physiology, and the diseases of the ear, he shows his practical acquaintance with aural disease in the various cases brought under his treatment."—*Glasgow Daily Herald*.

"The ear is a very complex and delicate organ, containing different structures of great delicacy and minuteness; every portion is liable to disease requiring its own particular treatment. Writing on this subject, Mr. Smith says, of all the ailments incident to this important organ, acute inflammation is the most painful and serious in its results, if its progress be not arrested. . . . In very severe cases the petrous portion of the temporal bone becomes diseased, and thus establishes a ready communication with the membranes of the brain. . . . These remarks and extracts have been called for from the fact of a distressing case of acute inflammation of the ear having occurred in our own neighbourhood, in which the treatment adopted by Mr. Smith was highly successful. Mrs. ———, the wife of a manufacturer at Brechin, had been deaf for many years; lately she was violently attacked with acute inflammation in the middle and internal ear; so rapid and dangerous was the inflammatory action, that it was extending to every portion of the internal ear, and from thence to the brain, and externally through the mastoid bone to the outer part of the head. The usual treatment in such cases is to make a free incision to the mastoid bone, and thus reach the seat of the disease. To obviate the necessity for this painful operation, Mr. Smith introduced a tube through the nose into the Eustachian tube, and thence into the middle ear, by means of which he was enabled to apply the necessary applications to subdue the disease at its very origin. The result of the treatment is very satisfactory, the inflammation having subsided, the pain disappeared, and the hearing power restored."—*Dundee Courier*.

"We strongly recommend this work to our readers, believing in the words of the author that, with regard to aural diseases, "there are many vulgar errors to be exploded, many wrong notions to be set right, and that there is much room for sound instruction" on the subject. Mr. Smith advocates a diffusion of a general knowledge of the diseases to which humanity is prone, and since knowledge on these matters is desirable, it is certainly equally desirable that it should be communicated by those who are thoroughly qualified for the task. No one who reads this work on the ear will doubt the author's qualification to deal theoretically and practically with the branch of his profession to which he with so much enthusiasm, and with such eminent success, devotes his attention. Some really wonderful cures of deafness, and several nice and very difficult operations he has performed have come to our own knowledge. One remarkable case we may mention, a deaf and dumb boy was brought to him in the faint hope that something might be done toward affecting a partial cure. Mr. Smith took an interest in the case, and his operations were attended with most gratifying results. The boy, formerly deaf to the loudest sounds, signified that he heard—not perfectly, certainly, but with an acuteness far beyond anything his friends had ever hoped for him. The striking of a clock, the opening and shutting of doors, and similar sounds are distinctly heard by him."—*Elgin Courier*.

