

Drawing The Easy Way

NC
670
.S45



By Cobb X. Shinn



Class NC 670

Book S 45

Copyright N^o _____

COPYRIGHT DEPOSIT

DRAWING
THE EASY WAY



DRAWING

**M'ADE E'ASY
FOR YOU**

COBB X. SHINN



S63

DRAWING THE EASY WAY

By Cobb X. Shinn



ALBERT WHITMAN & COMPANY
PUBLISHERS

CHICAGO

U. S. A.

© 1927

DRAWING THE EASY WAY

Copyright 1923, 1924, 1927

By Albert Whitman & Company

MC670
S45



©CIA1068051

A "JUST RIGHT" BOOK

Made in the U. S. A.

FEB 17 '28

INTRODUCTION

How to Become an Artist? has always remained a great question to many people who would have liked a ready medium to aid them in learning the rudiments of expressing in pictures their impressions of places and objects they have seen.

Not everyone can be an artist, yet everyone can learn to draw well enough to make very good pictures of the places and objects he has seen. You can draw such pictures with a very few lines, as shown in this "new-way" book. If you were trying to describe a place with words you would have to write many, many of them.

After a little practice copying the various models in this book, you will be surprised to see how easy it is to place on paper "what your eye sees."

COBB X. SHINN.

HOW TO BECOME AN ARTIST



1



2



3



4



COBD X. SHINN

565

THE CARDINAL OR RED BIRD
FOR YOU TO DRAW

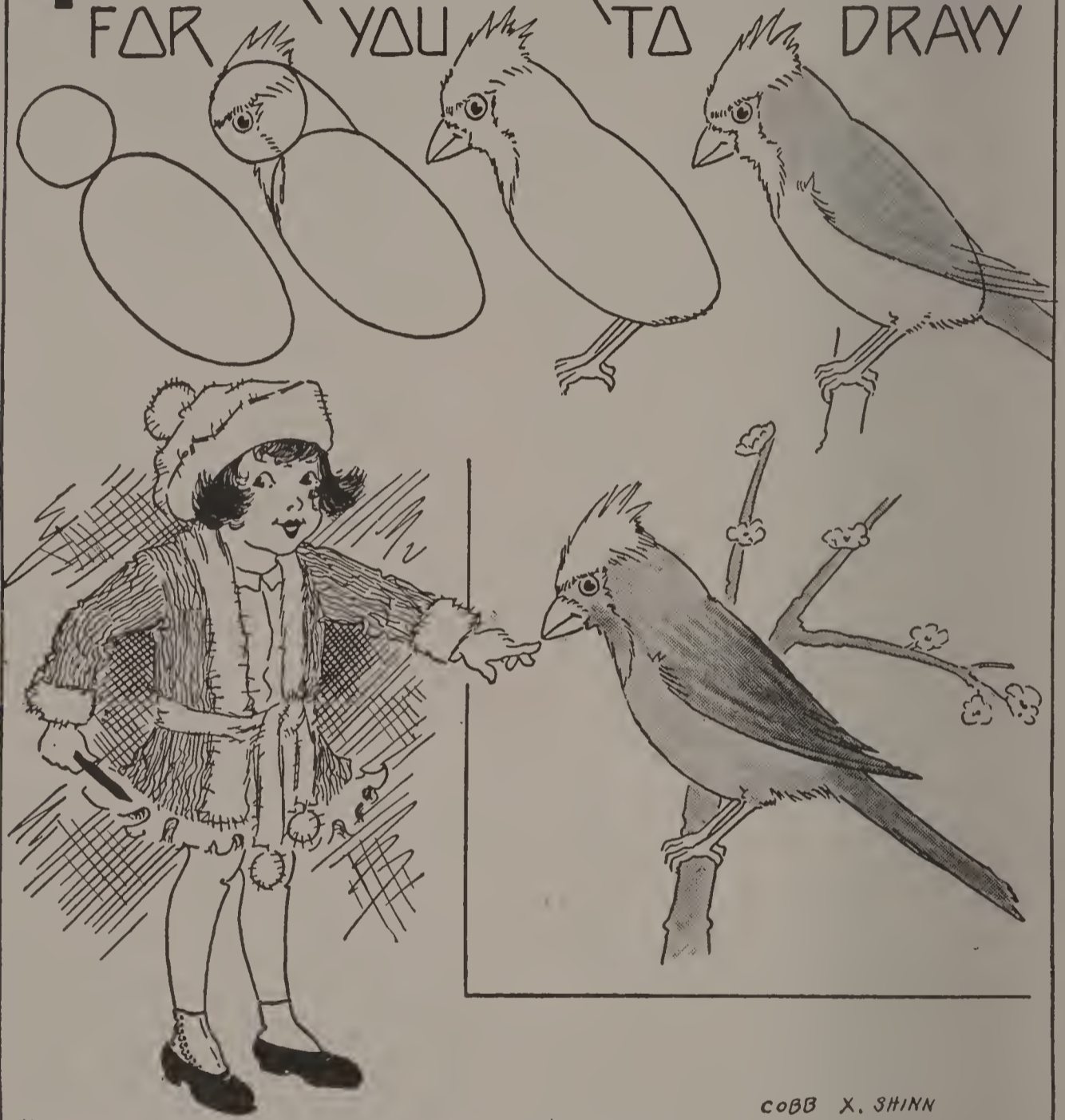

DRAWING THE EASY WAY



WHEW-EE, whew-ee, whuit, whuit, whuit, purty, purty, purty," he whistles. Everybody knows and loves to hear this song of the Red Bird. He is one of what the bird books call "Permanent Residents," for he is with us the year round. And don't you think it pleasant for all of us that a beautiful bird like the Red Bird lives with us through the long winter months? When the winter's snows have covered the ground, do you ever think of paying him for his song with a few crumbs of bread?

HE IS A MEMBER OF THE CROWY FAMILY

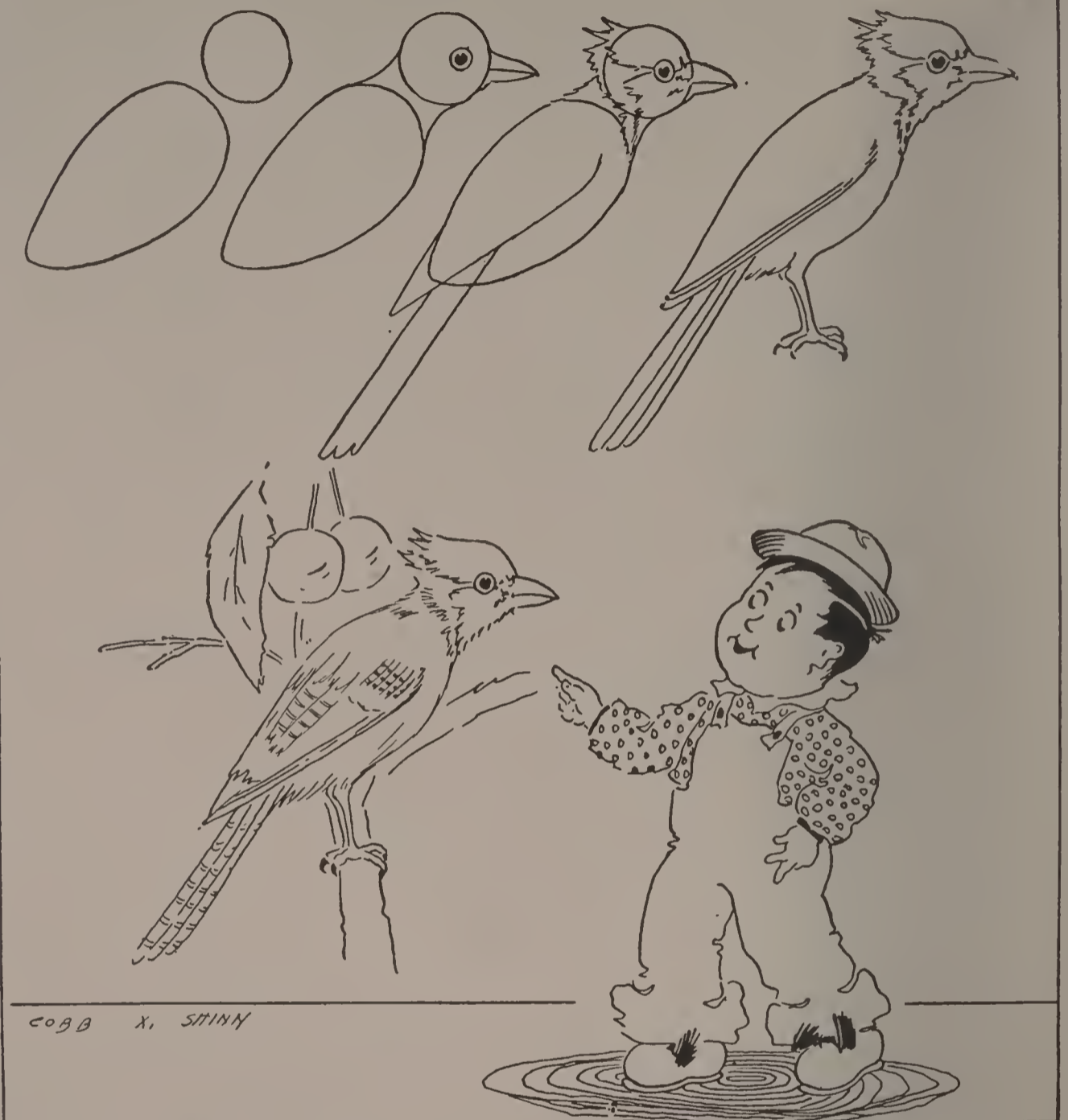

WHILE the Blue Jay is a member of the Crow family, he is not such a plunderer as the Crow. In fact, he does a great deal of good by eating many insects that feed on the foliage of trees. He has a bad habit of being meddlesome. This makes him very unpopular in bird society and when he approaches a tree, the other birds fly away.

MISTER OSTRICH

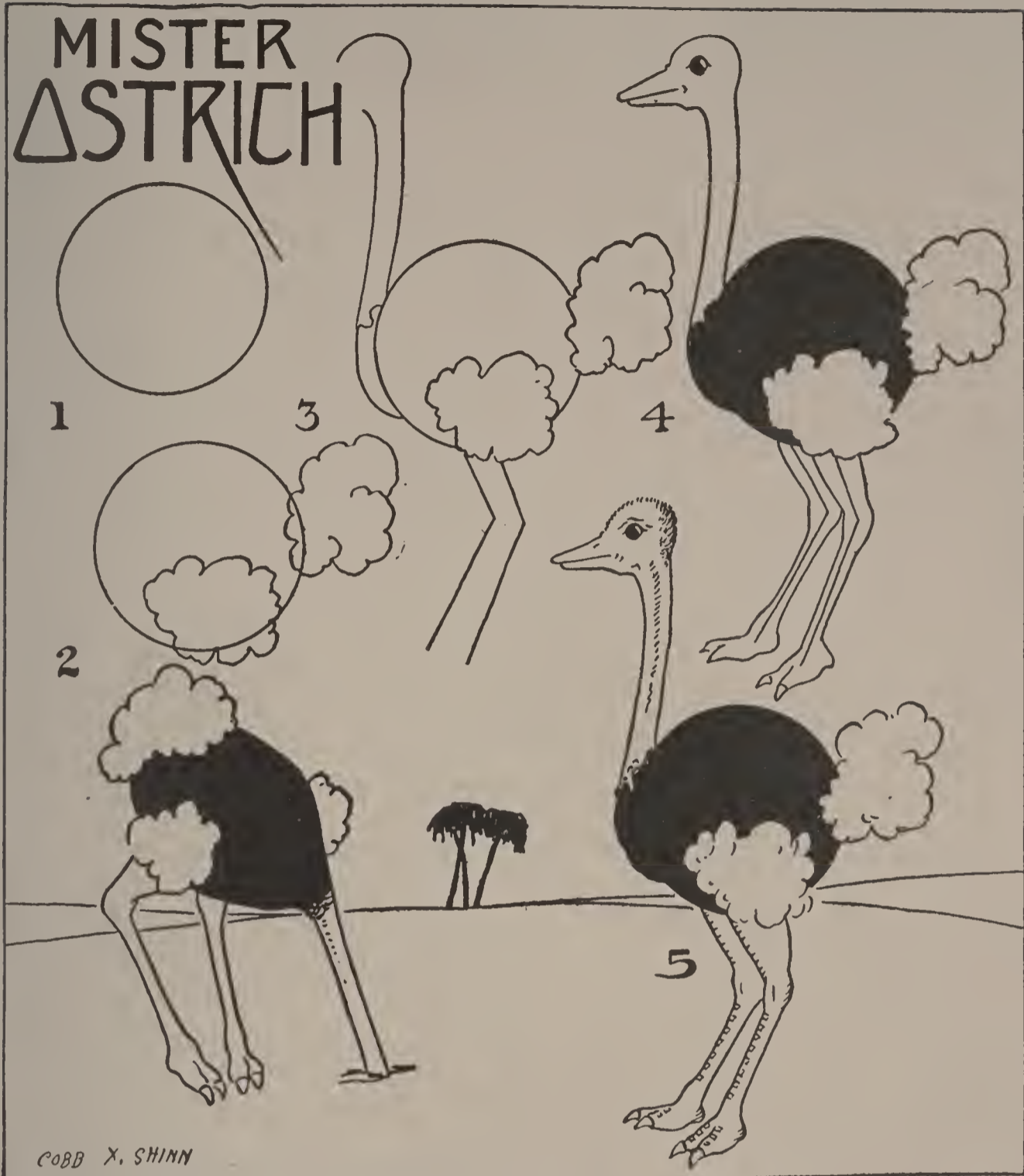

YOU start with a circle to draw this Foolish Bird, Mister Ostrich, who believes that if he can't see you, that you can't see him. He is the largest bird in all the world, but he can not fly. Oh! my! but how he can run and kick with those long legs.

OLD DOCTOR STORK

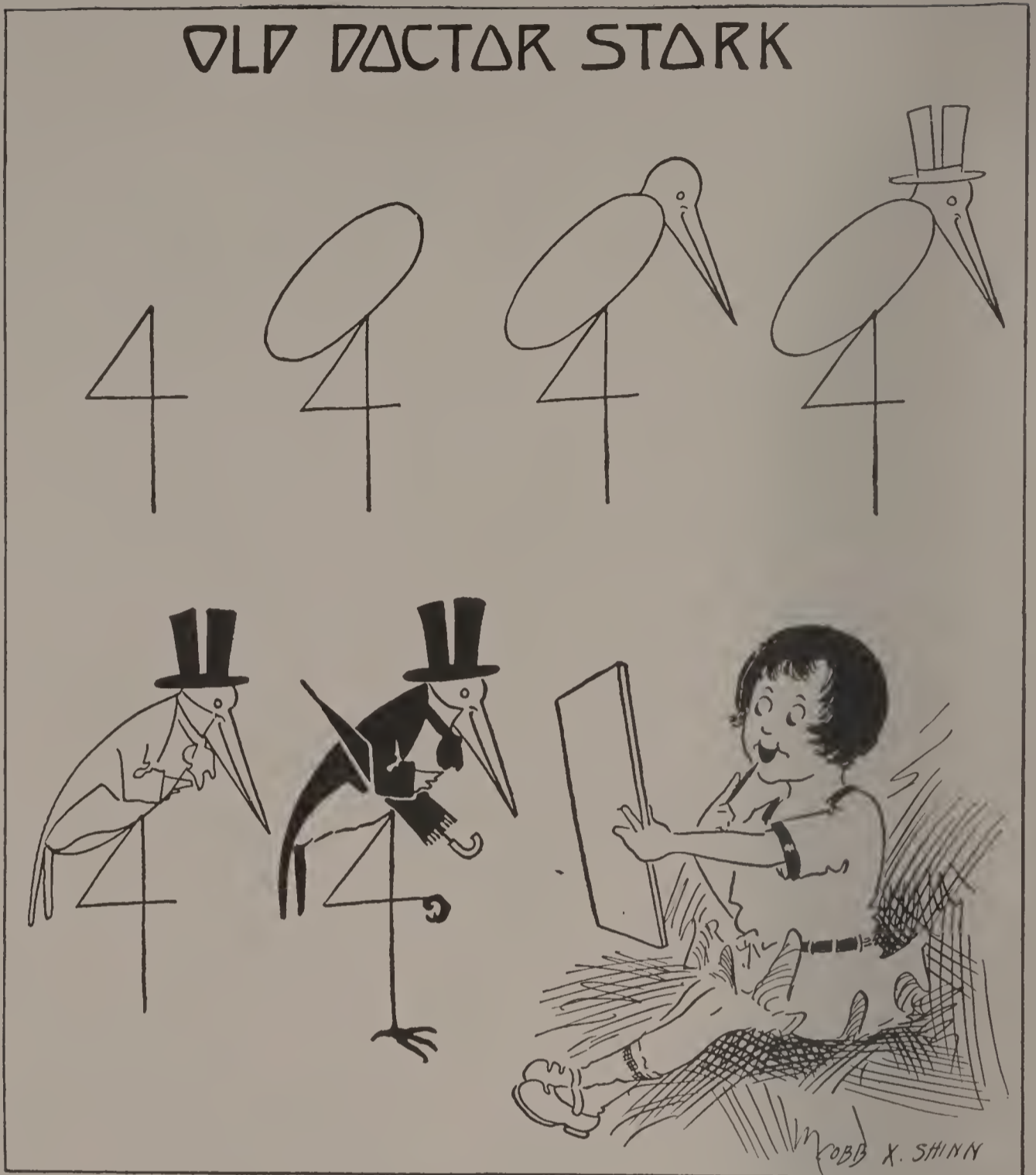

OLD DOCTOR STORK is a funny old bird and is very easy to draw. First you just make the number four, then place a long oval on the top of the four and now you can make his funny looking head. Then you start to put his clothes on him, his hat first, now his collar, coat and place an umbrella under his wing. There you have the Doctor complete.

NOW YOU CAN DRAW THE WISE OWL
THAT IS A VERY HANDSOME FOWL

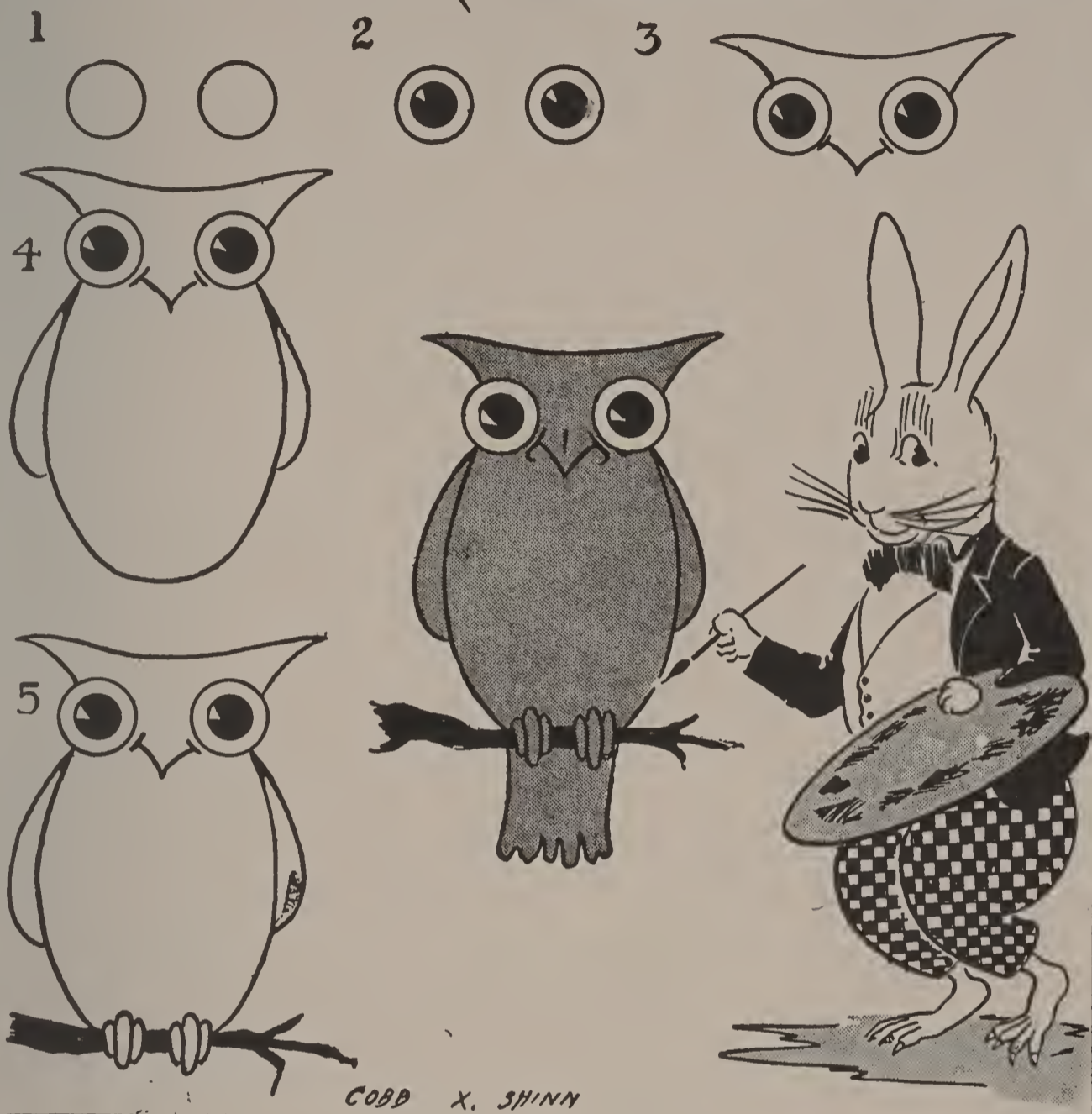

PETER RABBIT shows us the trick of drawing the "Wise Owl" and it is very easy to do. Every boy and girl should be able to make a dandy picture of this "Handsome Fowl." Now make your little eyes get busy and hunt up your pencil. Then, after you have found it, make your little fingers get busy and use it.



WHEN you first look at a Peacock you would think that he was hard to draw. But if you will just start with an oval, you are going to find it easy to do. Then add his head. Now his feet and last of all his wings and beautiful tail.

THE ZICZAC

'THE TOOTHPICK OF THE CROCODILE



THE Crocodile does not have many friends; but his best friend is the Ziczac bird, for he warns him when danger is near. More wonderful still is the way the crocodile will hold its mouth open for hours at a time, letting this little bird run in and out of his mouth picking the fragments of flesh which have collected between the crocodile's teeth.

The Secretary Bird
FROM FAR AWAY AFRICA

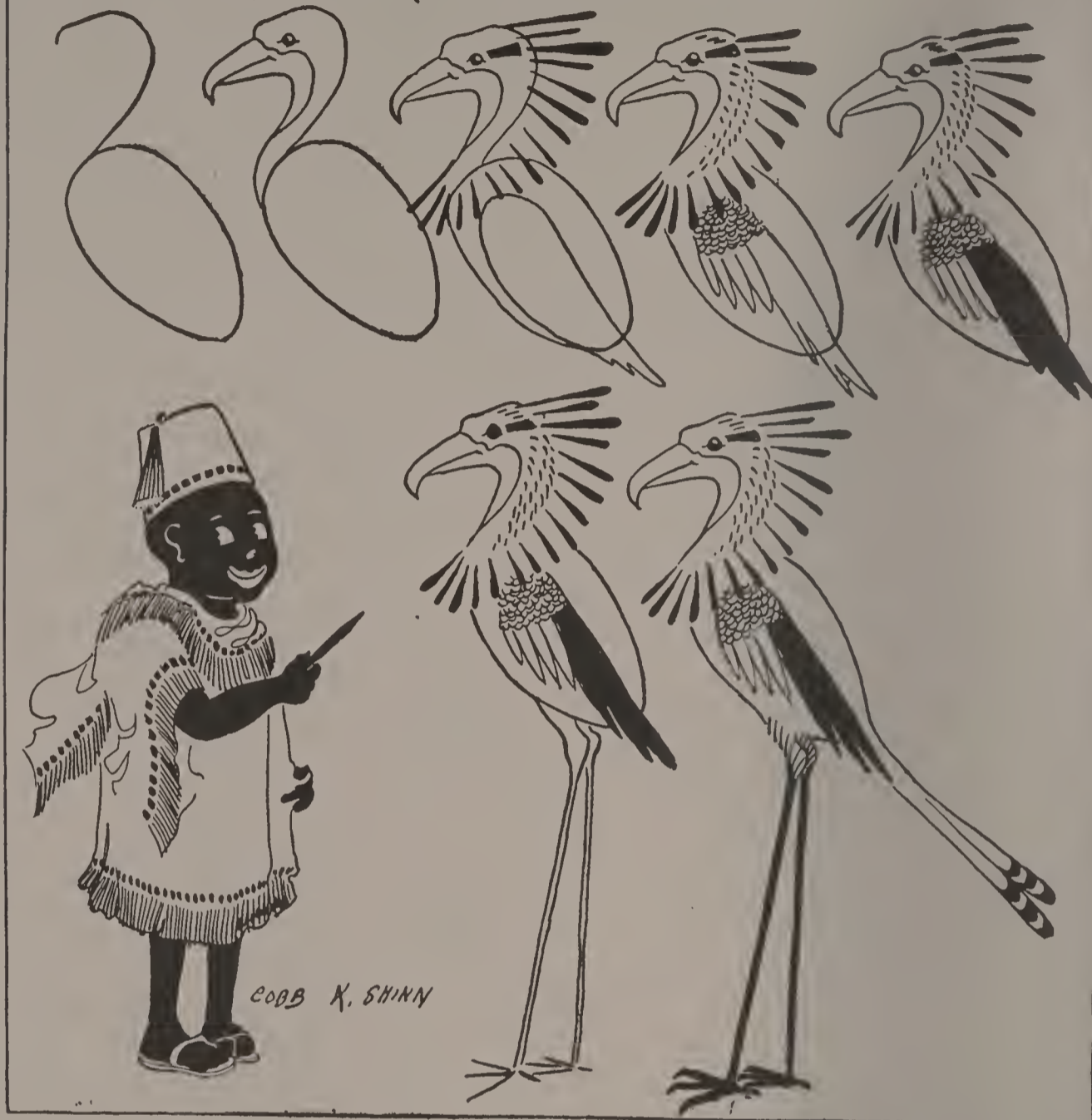

IT GETS the name of Secretary Bird from the feathers that grow out of the back of its head, looking like quill pens behind the ear of a clerk. Its food consists of reptiles. Among them is included a great number of poisonous snakes. In Africa it is so highly valued as a foe to snakes that a fine is imposed for killing it.

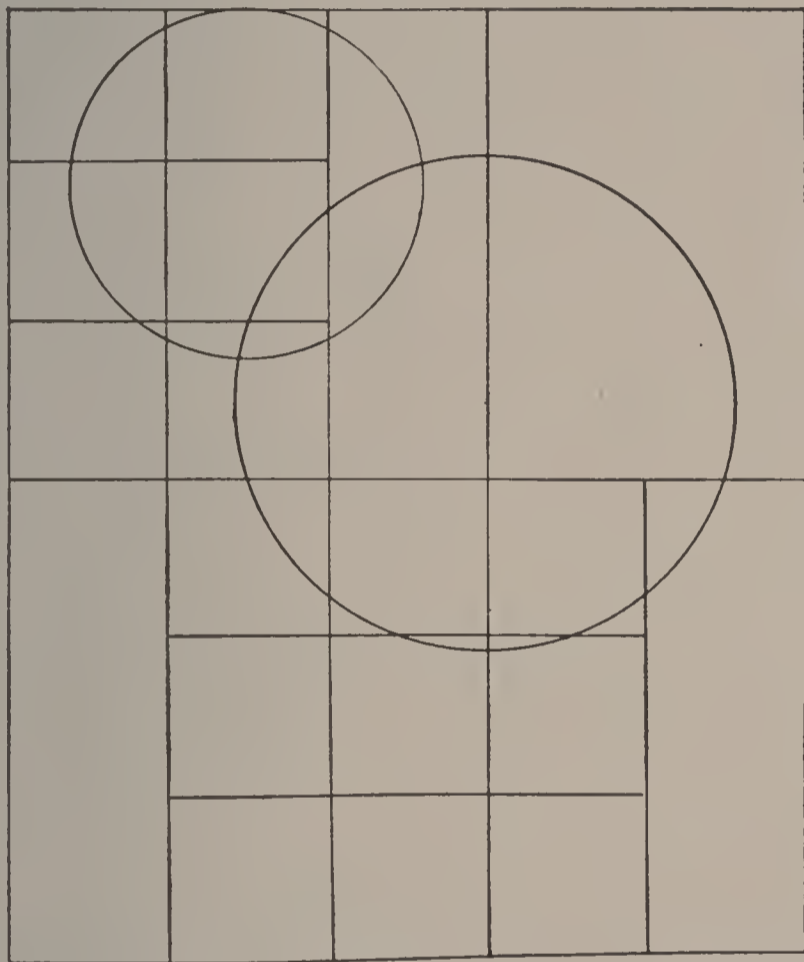
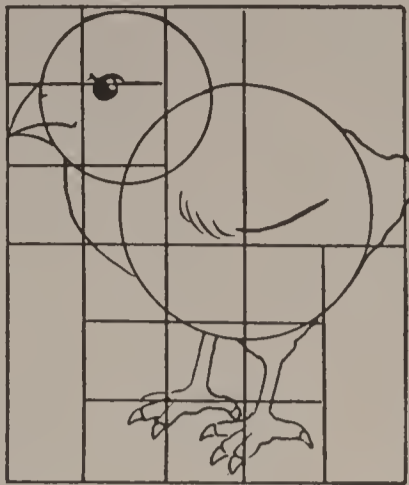
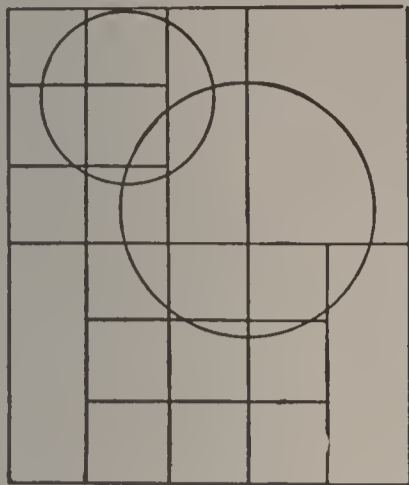

The
EASY WAY
to
DRAW

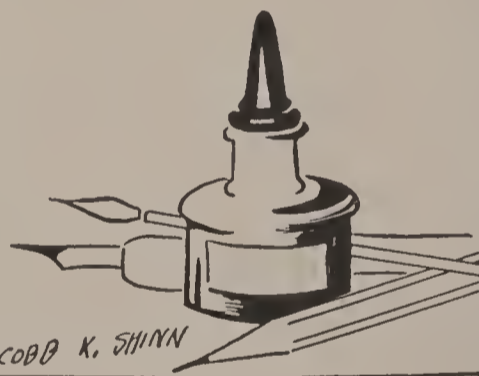

COBB K. SHINN

TAKE your pencil and see if you can draw the little chick in the space that is squared off. You'll find it so easy to do that you will try it on a separate piece of paper. Erase the lines of the square when you have the picture completed.

HERE IS A DEAR LITTLE BABY CHICK
FOR YOU TO DRAW

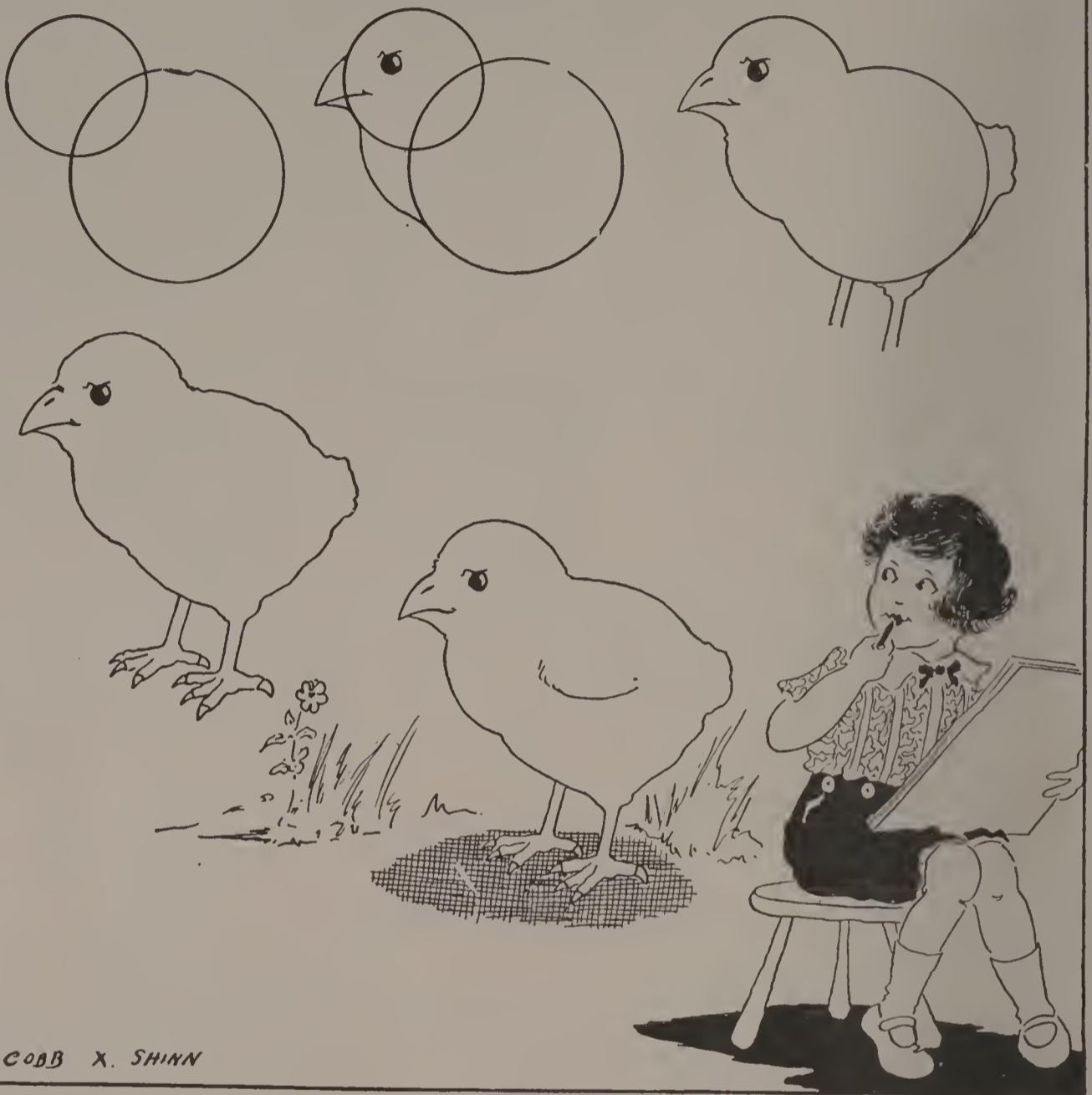

COBB X. SHINN

HERE is a dandy lesson and so very easy to do. You can use your compass to make the two circles and then it is easy to make the bill and the eye. And not a bit hard to draw the tail and legs and feet. After you have made this one, try and see if you can make a picture of Chick running or trying to pull a fishing worm out of the ground.

THE COCK DOTH CROW
TO LET YOU KNOW,
IF YOU BE WISE,
'TIS TIME TO RISE.

1

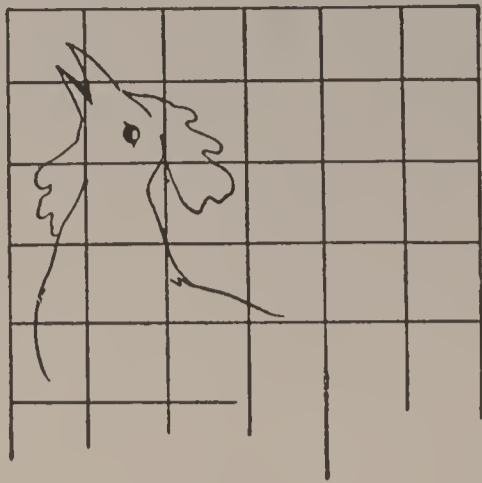

2

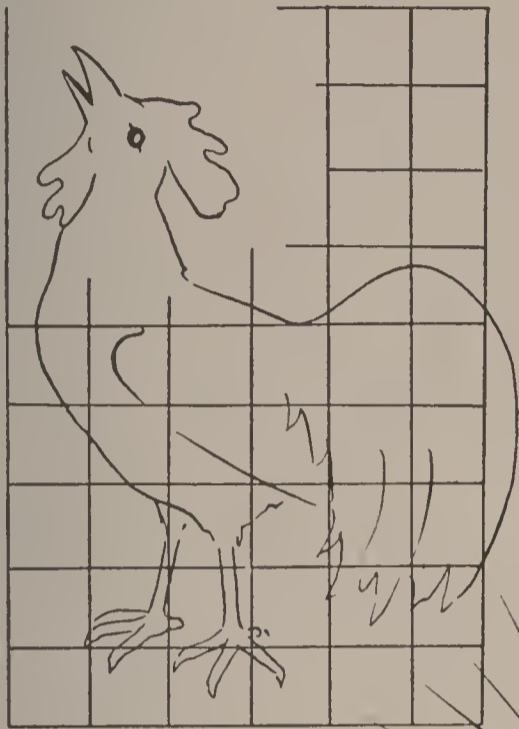

3



FOR EARLY TO BED
AND EARLY TO RISE
MAKES A MAN HEALTHY
AND WEALTHY AND WISE

COBB X. SHINN

THE easy way to copy pictures, is first to mark your picture off in squares. If you want to draw a large picture of this Rooster, first take a large piece of paper. Mark off a space twenty-seven inches long and eighteen inches wide, then divide it up into spaces that are three inches square. You can see just what part of the rooster goes into each square and can't help getting the right proportions.

PENGUIN

A QUEER BIRD FROM THE ANTARCTIC REGIONS

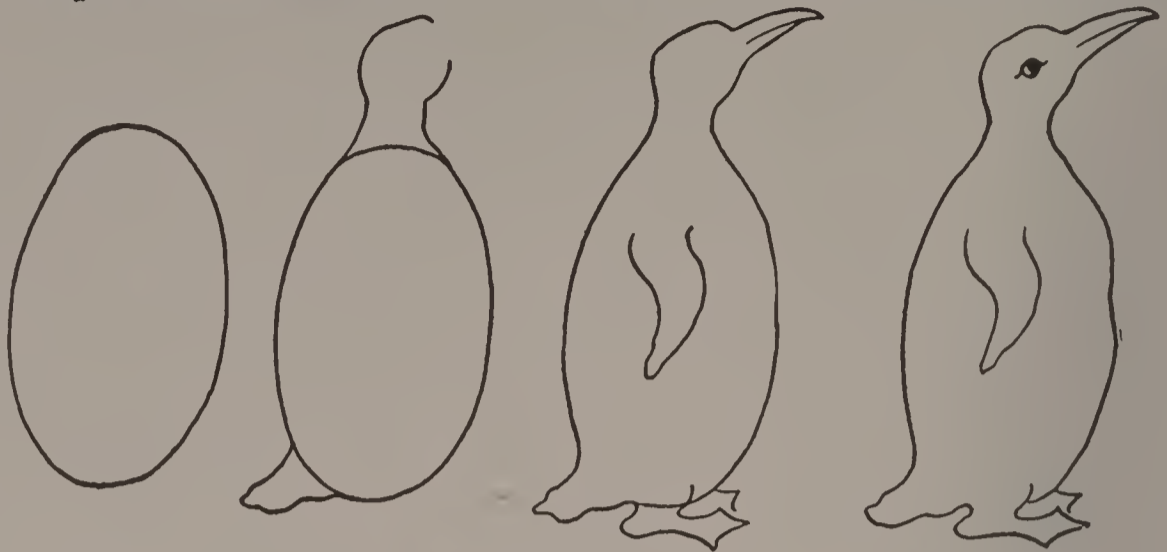

COBB & SHINN

WHILE Penguin is a bird, he looks more like a scarecrow. His wings are very small and are more like the flappers of the seal; these help to make him a good swimmer. He lumbers over the ground like a boy with his feet tied in a sack. The Penguin lives in the far south, where great numbers of them will build a square village. Each family will have their little plot; the village has streets and lanes.

“CREAKETY-CREA-CREA” PLAYS THE MERRY MINSTREL



MOST people say that the Crickets are singing but they don't sing. They make the noise with their wings by rubbing them together. On one wing there are ridges and scrapers on the other; he works them about like you would a violin. Another very odd thing about a Cricket is that he doesn't breathe like you do, through a nose, but breathes through some tiny holes in the sides of his body.

OUR LITTLE FRIEND THAT WE
DON'T OFTEN SEE



YOU may not see this Little Friend very often, but you do get to hear him a lot. Mr. Katydid is very hard to find because of his color and you have to look very close to see him swinging on a blade of grass. He is just as hard to catch as his cousin the Grasshopper and he can both jump and fly. The next time you hear one, just try and see if you can find this pale green insect that says "Katydid."

“COME INTO MY PARLOR”
SAID THE SPIDER TO THE FLY

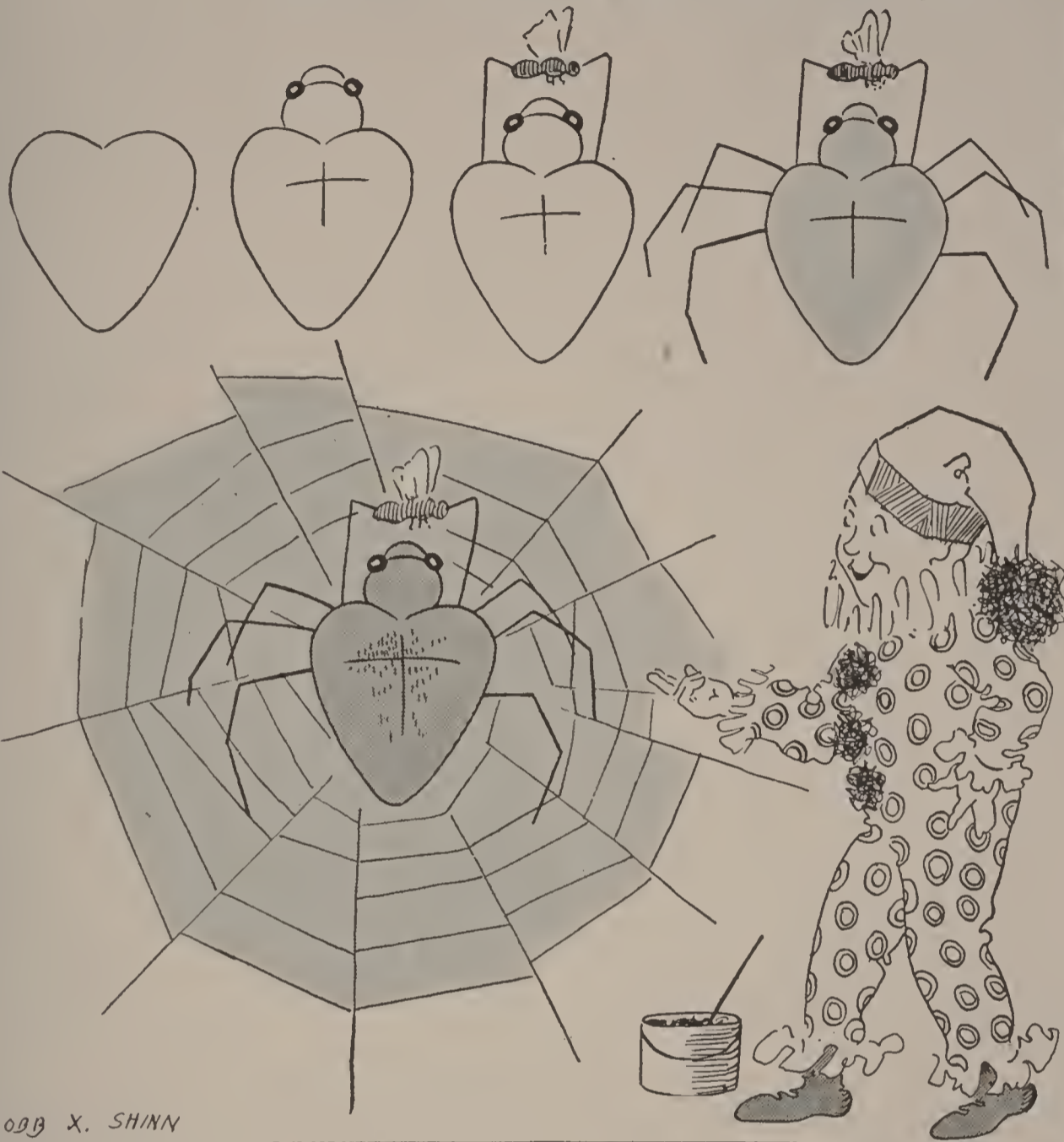

COBB X. SHINN

WHILE a spider is not a very pretty thing to look at, still this is a very good trick that the little Clown has worked out. Starting with a heart and just adding so very few lines, he changed it into a spider.

PEN AND INK SKETCHES OF TREES



APPLE
TREE

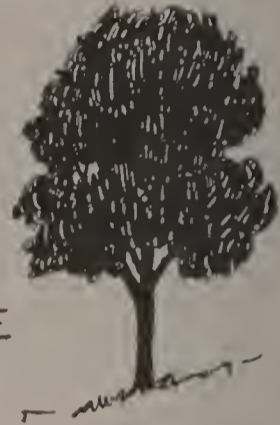
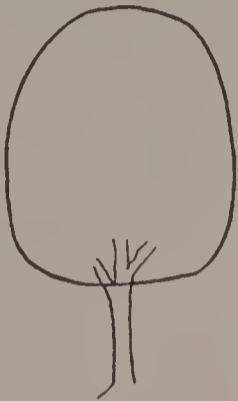

MAPLE
TREE

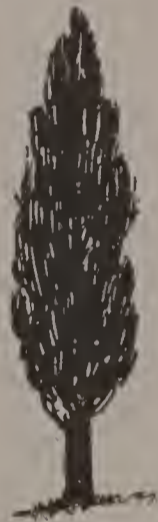

POPLAR TREE



COBB X. SHINN

DID you ever notice how some people can tell you the name of almost every tree and they will be a half mile or so away from it? Of course, they tell by the shape of the tree. So if you are going to make a drawing of a tree, the first thing you want to do is to get the general shape of the tree marked out first. After that you will find it very easy to make a good drawing of almost any tree.

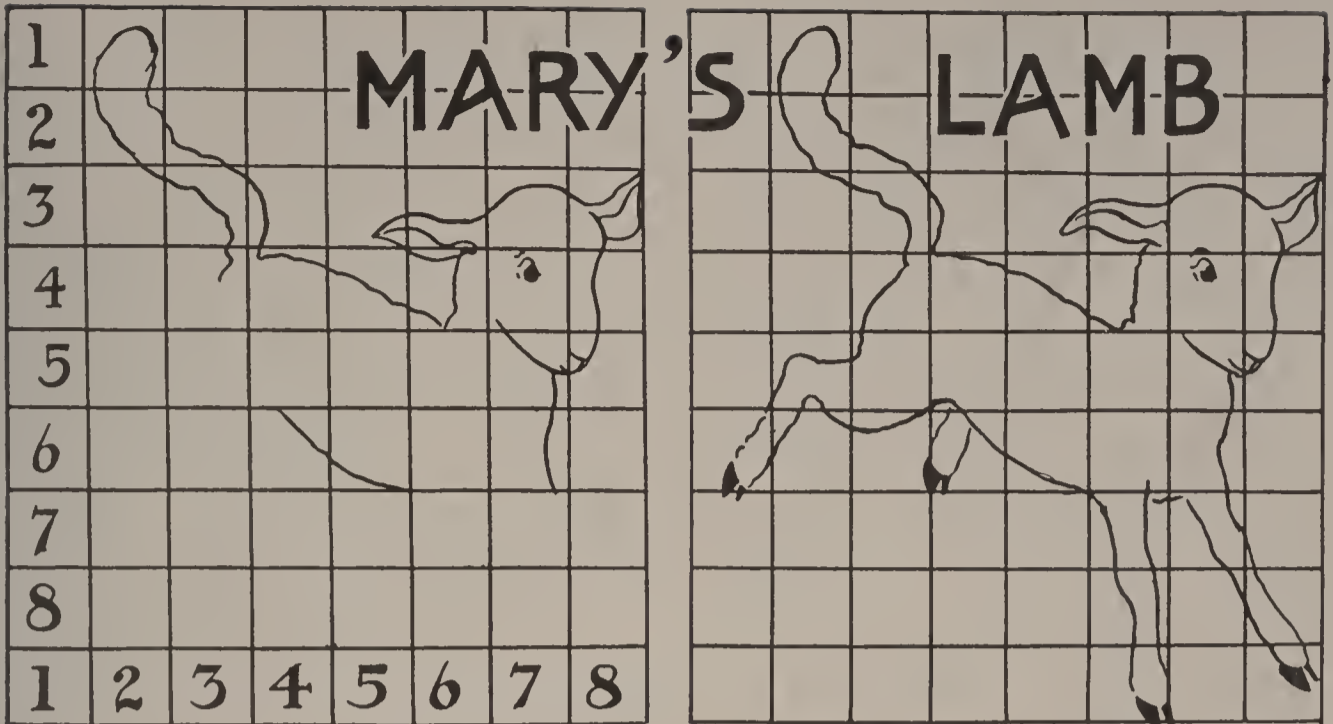

COPY X. SHINN



HERE is a different way of making a drawing. You can make a copy of any picture that you want to in this way. First divide the picture that you want to copy into squares and then make the same number of squares on the paper that you are going to make the drawing on. You do not have to make your squares the same size, but you do have to have the same number of squares on each.

THE HERCULES OF THE FOREST

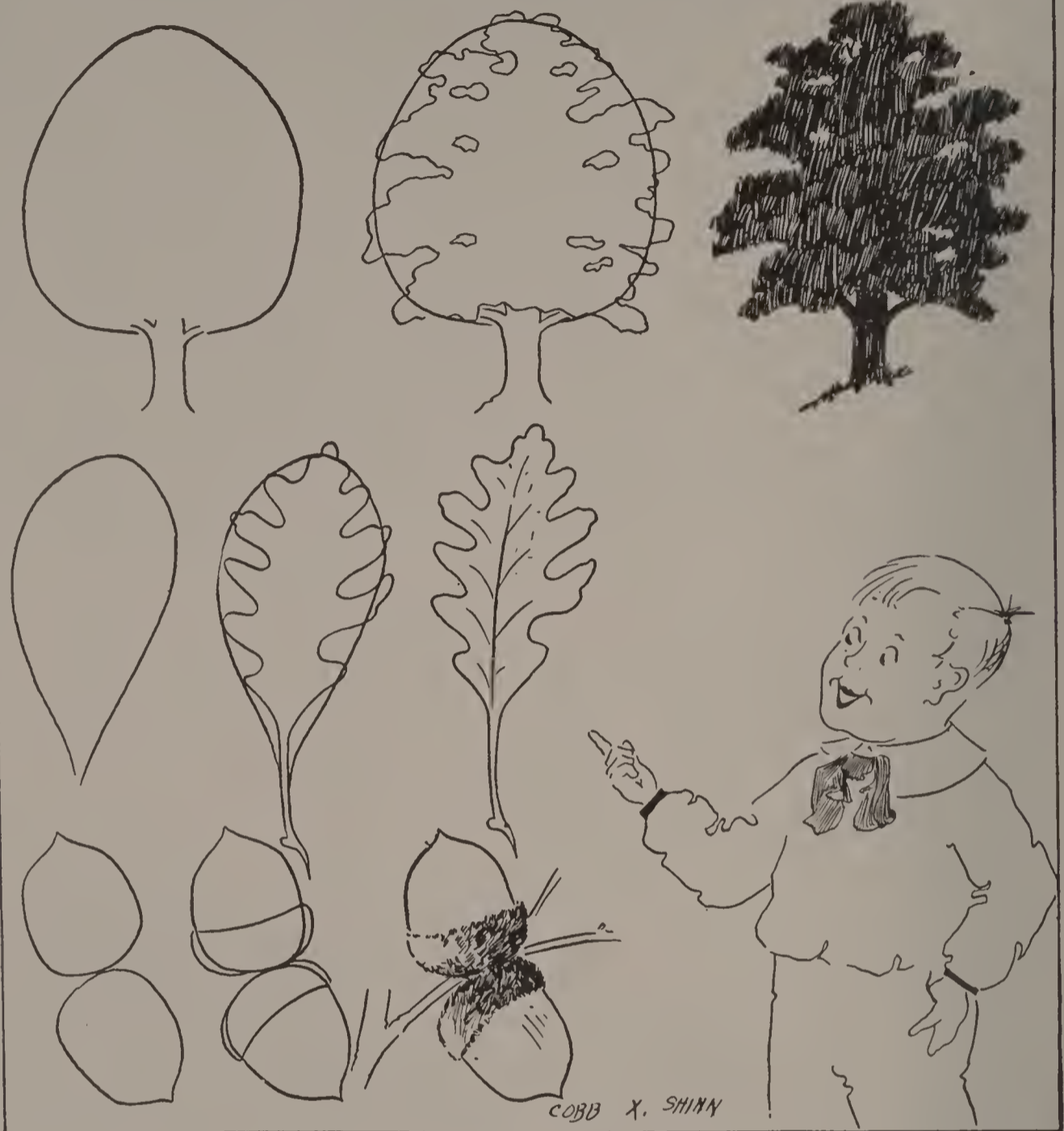

THERE are fifty different species of oak that are native to America and there are over three hundred different kinds in the world. Nearly all of them grow to be large trees and add to the beauty of the landscape. You can always tell an oak by its acorn. The leaves are always oval in shape, leathery and cut by deep bays. The drawing is a White Oak, the noblest of trees.

SOMETHING

TO
TO

DRAW
LEARN



DID you know that the Common Dandelion was not native of this country, but a European immigrant? Yet you will find it one of our best-known wild flowers from the Atlantic to the Pacific. Did you ever break the leaves or stem and see the bitter, milky juice flow freely? Of course everyone has bought its green jagged leaves on the market for food in the springtime.

HERE'S A DAISY OF A DRAWING LESSON

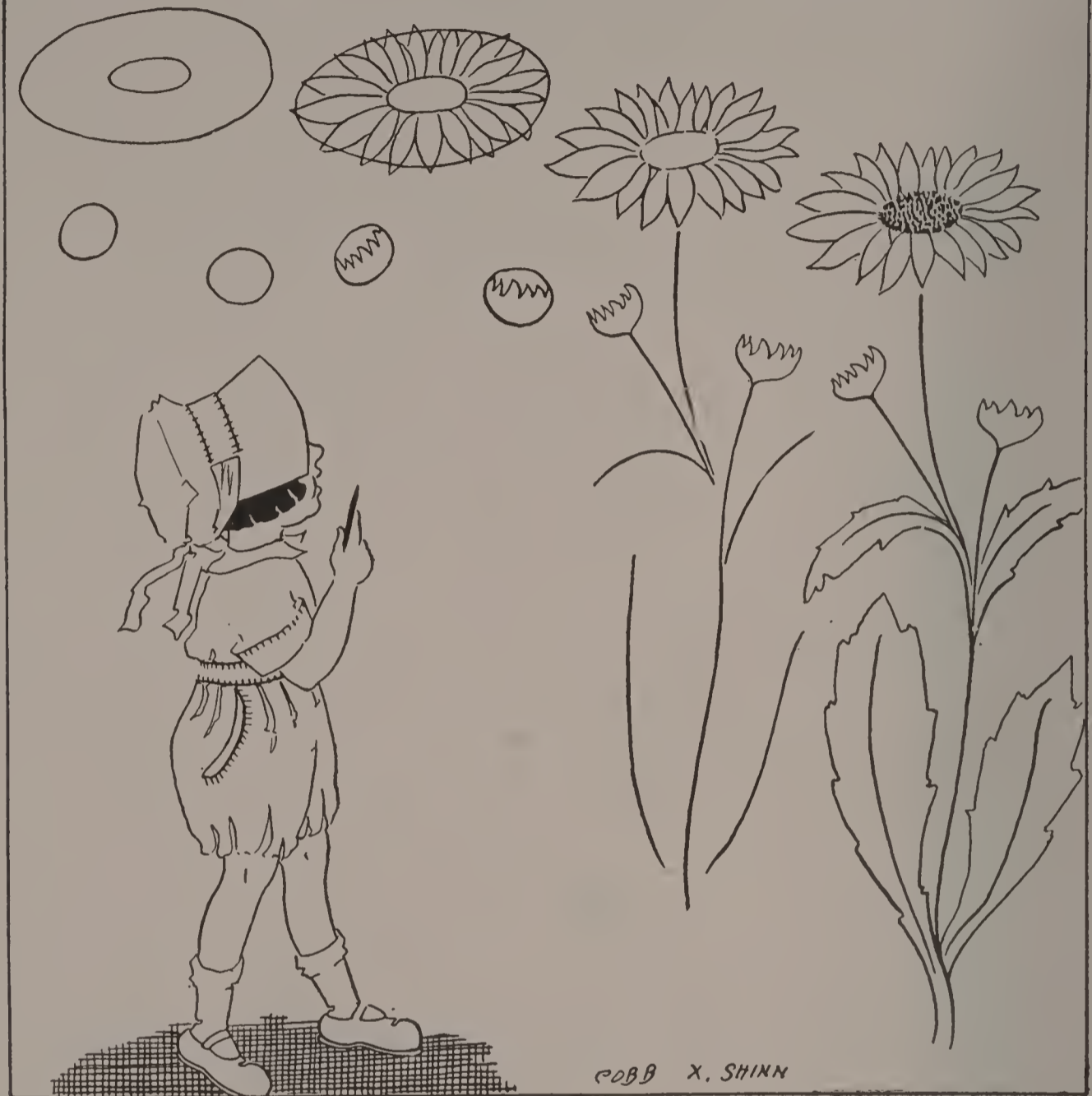

THE easy way to make a daisy, is first to make a dough-nut; don't get the hole in the center too large. Then start to make the petals of the daisy. Now you are ready to make the stem and leaves.

HOW TO MAKE A PAPER CARNATION

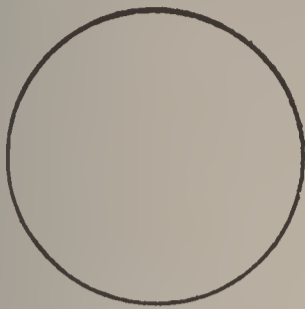

CUT TEN OF THESE ABOUT FOUR INCHES WIDE

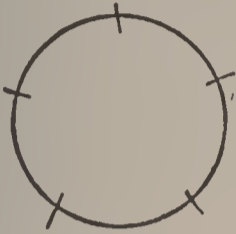

CUT ONE LIKE THIS TWO AND A HALF INCHES WIDE

4



3



5

COMPLETE

COBB X. SHINN

IT IS very easy to make a paper carnation. Use tissue paper, white or pink, and cut ten pieces like drawing number one. Fold two or three sections as in picture number three. Then bind them around with a thin wire and leave a long end for a stem. Now push the remaining sections of number one, unfolded, close to the center. Add the green calyx (like drawing number two) and bind the stem with green.

THE EASY WAY TO DRAW A DAFFODIL

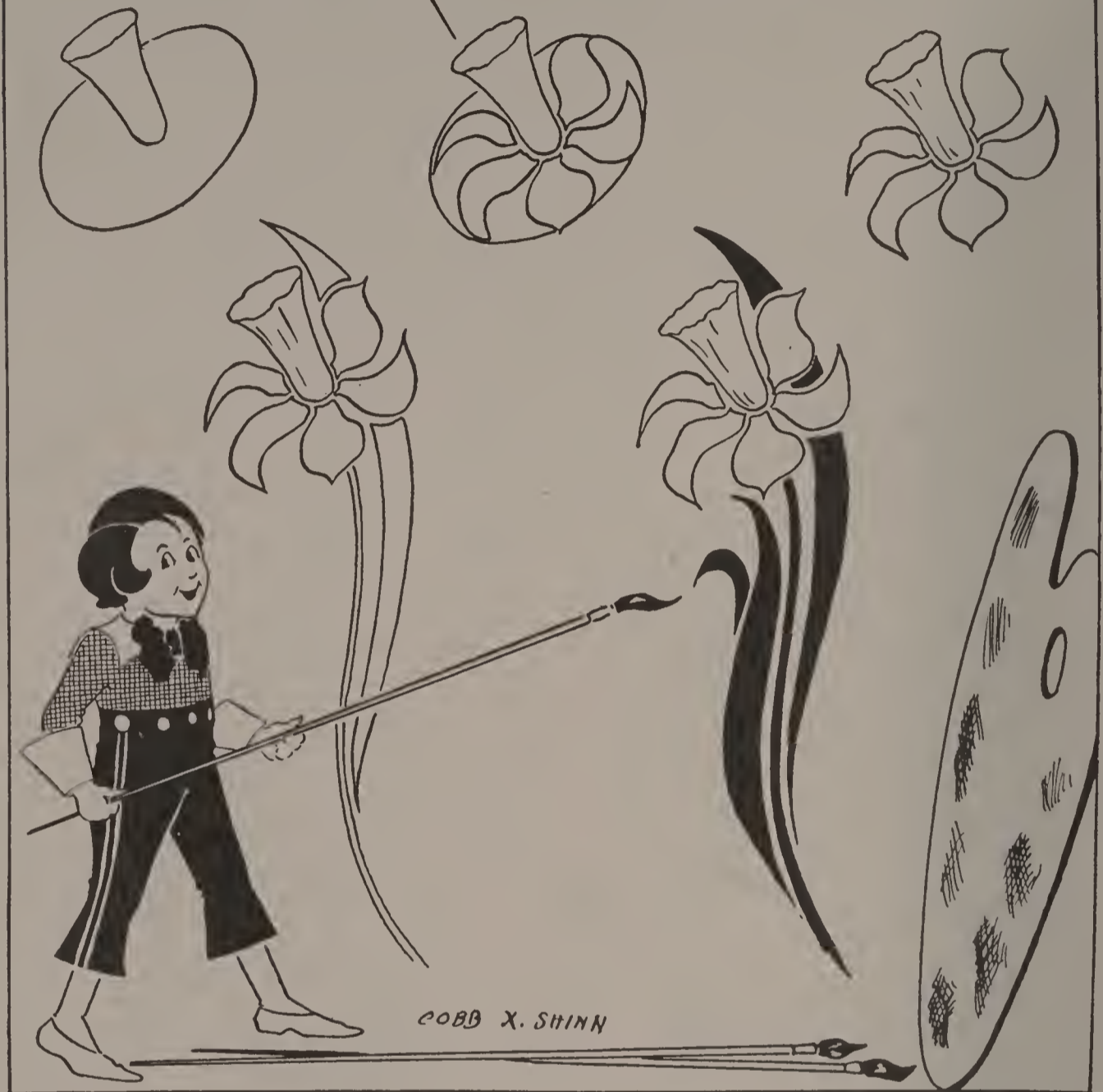

IF YOU want to make a drawing that is pretty to look at, there are no better subjects than flowers. The Daffodil or Narcissus, whichever you want to call it, is very beautiful and is easy for your little fingers to make. First try making just a single flower and then try to make a bouquet of them.

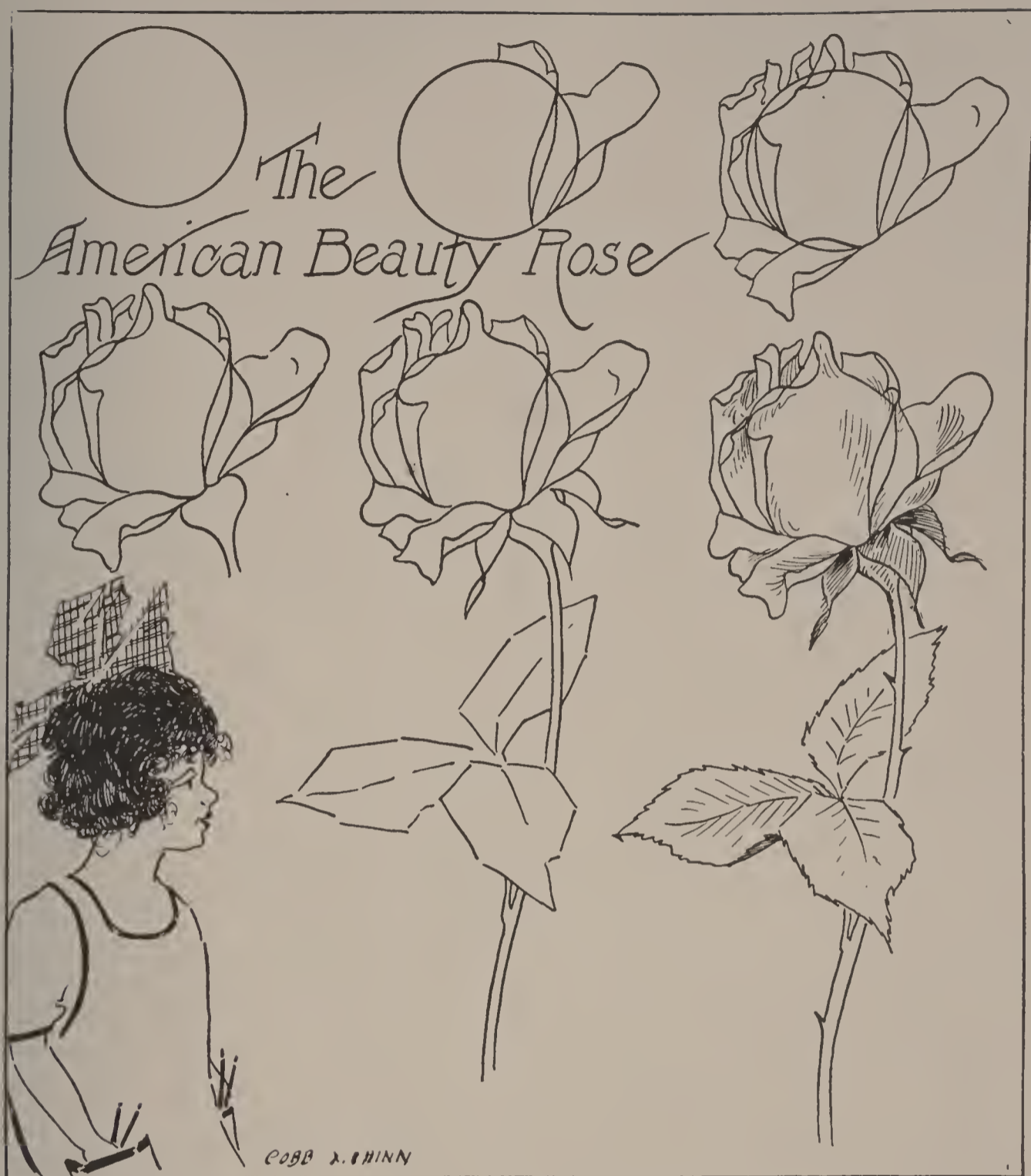

THE making of a drawing is very much like the building of a house. First of all you must have a foundation to build upon. Here a circle is used for the foundation of a rose. Little by little you add to the circle until you have completed the picture.

LOOK HOW EASY! IT IS TO DRAW!

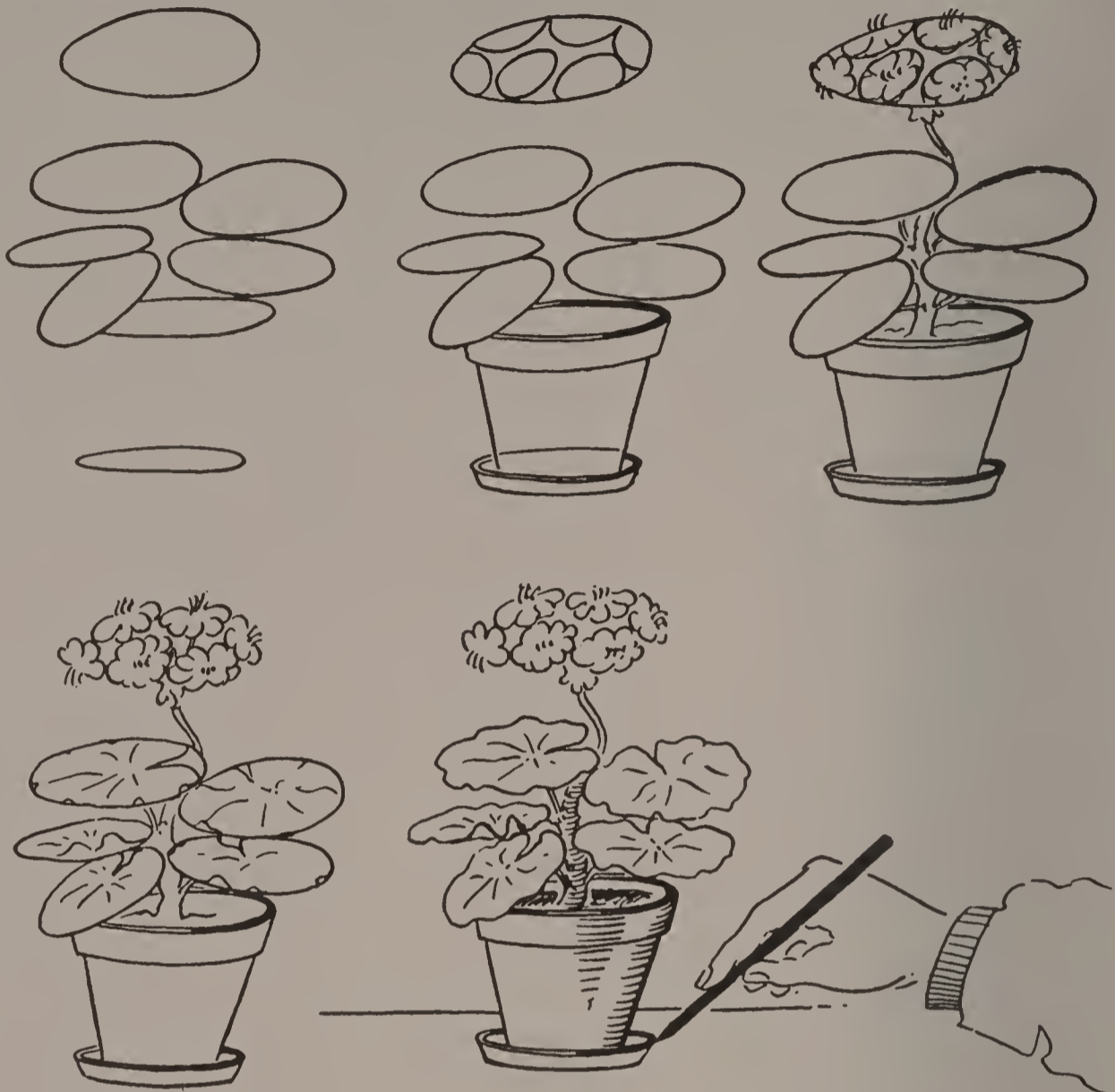

COBB X. SHINN

YOU would hardly think that this lot of plates or circles could be turned into this beautiful potted flower, but the artist has shown you, step by step, just how it is done. It is very easy to do, so try and see if you can't make one just as good as this one.



SEE HOW EASY IT IS TO DRAW A TULIP



.COBB X. SHINN

IF YOU should break the small end off of an egg, the shell would then be about the same shape as a tulip. So the easy way to draw a tulip is to make an egg first, then draw in the leaves of the flower. Now you are ready to add the stem and the other leaves. If you want to make your drawing very pretty, you should take your water colors and tint your drawing.

A NATURE STUDY

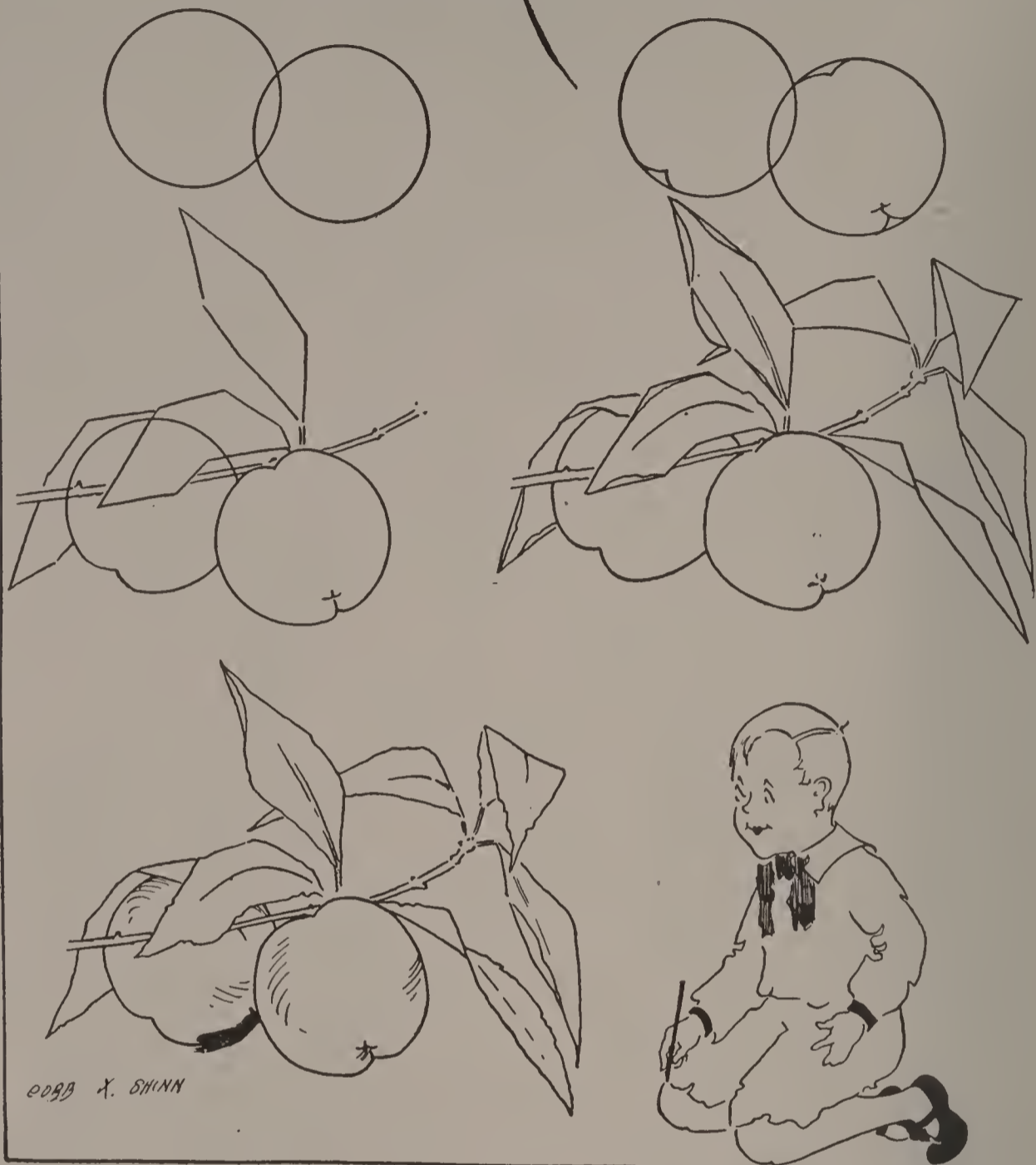

IN MAKING nature studies it is the best rule to keep the drawing simple, using only a very few lines and making each line mean something. Then if you want to take your water colors and make a color drawing you will find it very easy to do. Try coloring this drawing of peaches.

AND HERE'S WHAT YOU CAN MAKE
OUT OF A LOT OF CIRCLES



DON'T you think it rather odd that this lot of circles can be made into an attractive drawing of a bunch of grapes? You just make a lot of circles and show them to Mother or Father and see if they can guess what you can make of them. All you have to do is to blacken in the circles and leave a high light every now and then in a few of the circles.

SHOWING HOW A LITTLE ESQUIMAU GOES FISHING



WAY up in the Land of Ice and Snow, lives our Little Friend the Esquimau. He loves to go fishing just the same as any little boy or girl, but he has to chop a hole in the ice. And here we have the picture of him, which is very easy for you to draw.

A STRANGE CREATURE THE FLORIDA MANATI



THIS strange animal lives along the coast of Florida. It comes up the rivers and lagoons, where it feeds on grass and other water plants. Some of them grow to the length of 15 feet and weigh 1500 pounds. Their flesh is good to eat, but there is a penalty of \$500 for killing one. They are a very mild and inoffensive animal. In captivity they soon learn to eat grass out of your hand.

KING OF FRESH-WATER FISH

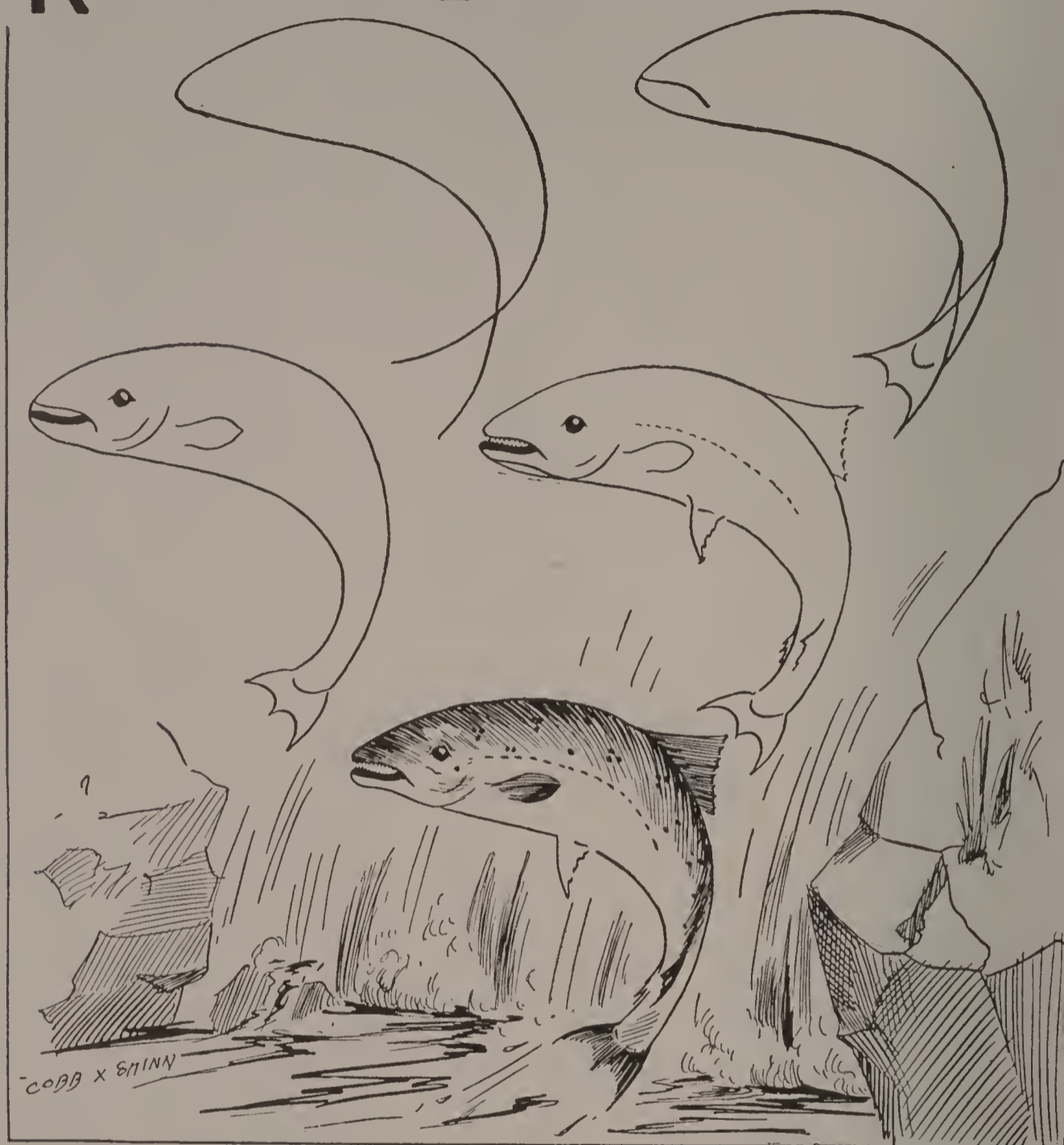

IN THE spring the salmon come out of the Pacific and swim up the rivers. Up swirling rapids and jumping cataracts they go—on and on—until they reach the place where they were born. There they lay their eggs and die. The young salmon that are born from the eggs are only a year old when they begin to long for the open sea and go off down the river.

AN ODD WAY
BUT AN EASY WAY TO DRAW A FROG



COBB X. SHINN

IT IS so easy to draw a frog that every boy and girl should be able to make a fine picture of the fellow who sings us to sleep in the summer time. Starting with an oval and then adding to the oval little by little, the first thing that you know you will have made a dandy picture of Mr. Croaker.

OL' FUNNY FACE,
THE PACIFIC WALRUS

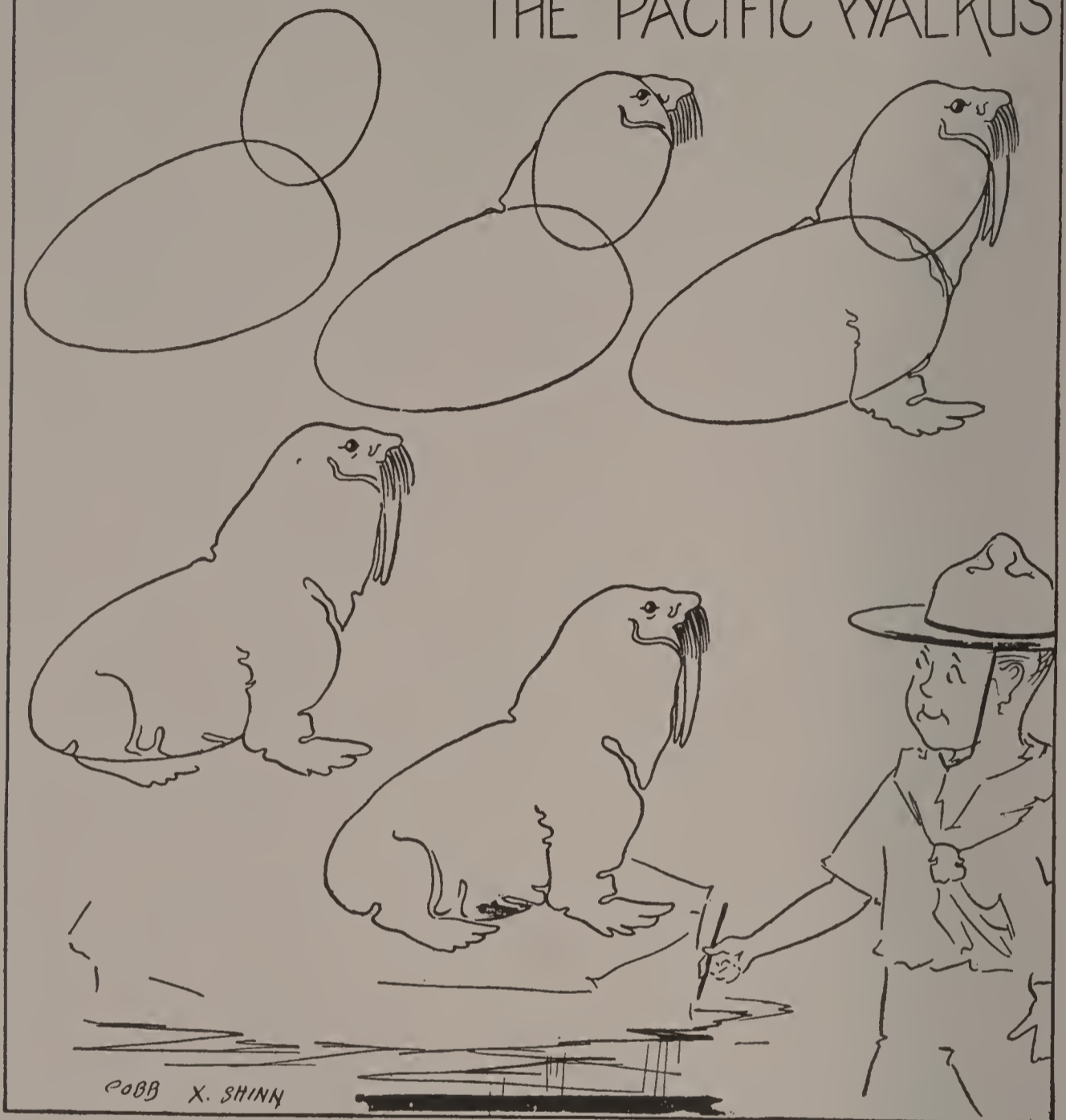

THESE strange beasts—Walruses, or Sea Horses—are found in the Arctic Ocean along the borders of pack ice. On the shore they move slowly and with much difficulty, but in the water they are very much at home, for they are very good swimmers. The two long tusks are used for digging clams and other shellfish, which they gather on the bottom of the shallow sea for food.

HOW TO DRAW and MAKE A TURTLE THAT WILL FLOAT

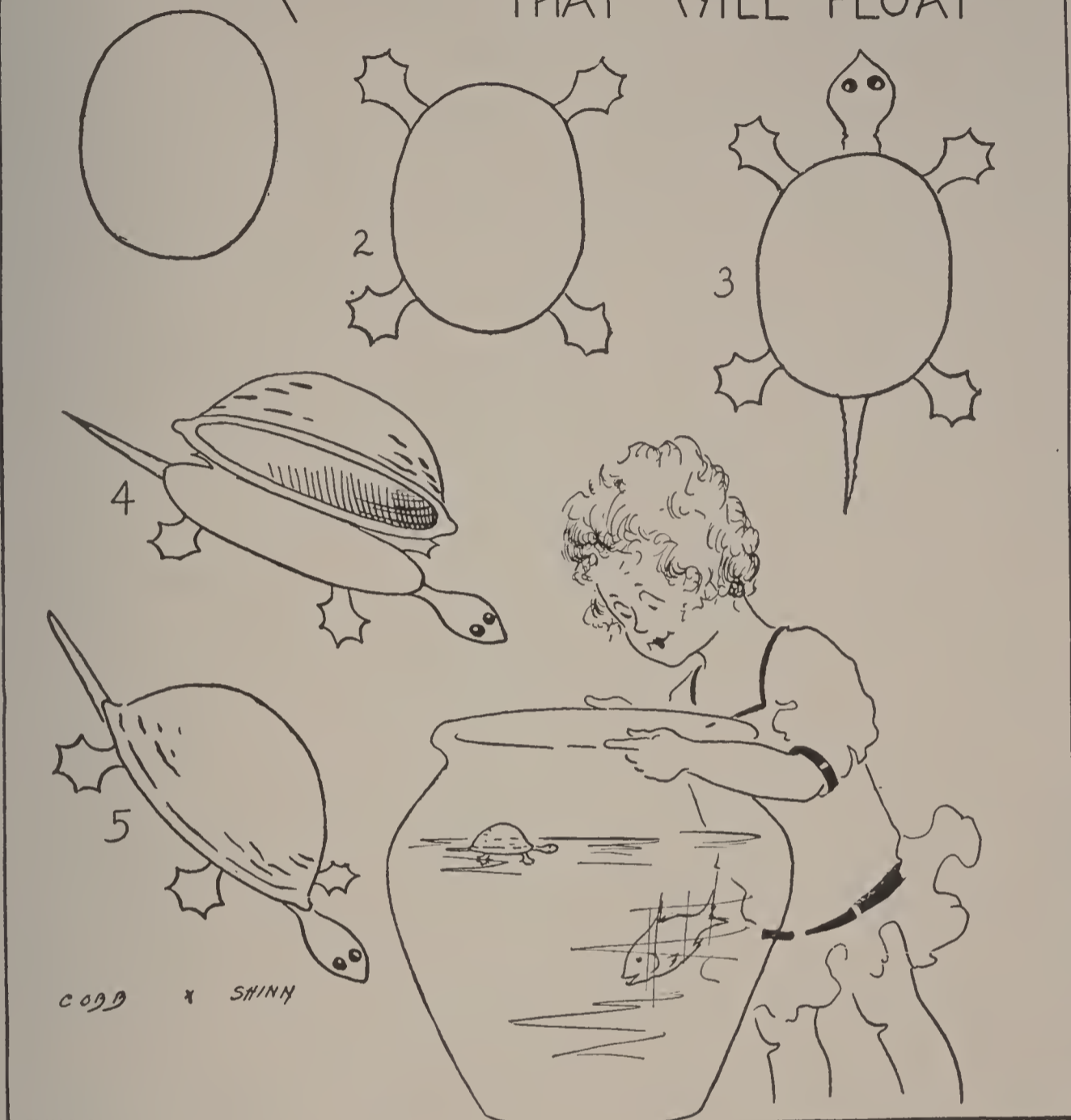

FIRST you take a half of an English Walnut shell and lay it on a piece of paper and mark out the oval. It is better to use waterproof or oiled paper if you have it. Then draw the feet on the oval and then the head and tail. Cut it out and paste it on the bottom side of the shell, using a little sealing wax or chewing gum for paste.

A CARTOON FOR YOU TO DRAW

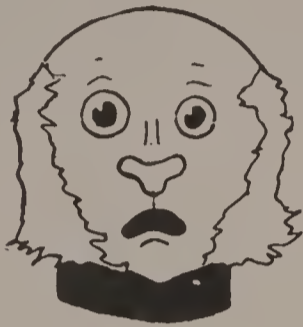
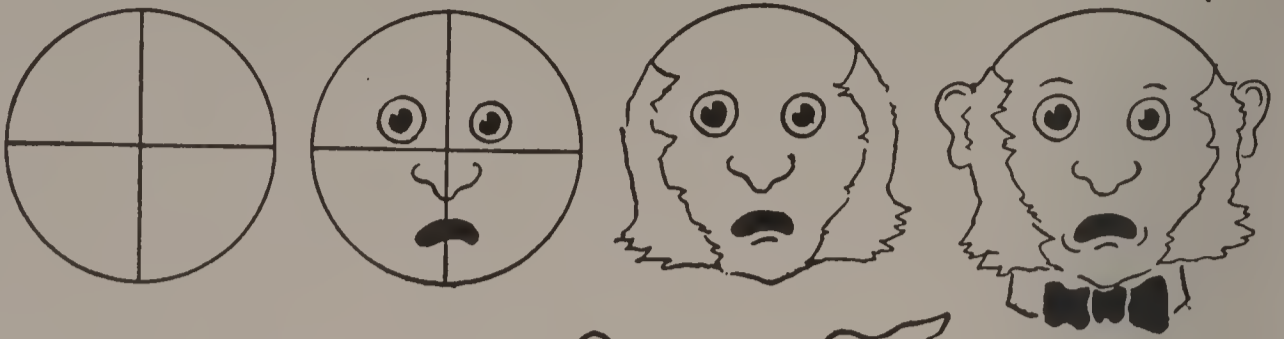

ERASE HIS EARS, CHANGE THE NOSE A LITTLE AND BLACKEN HIS COLLAR.



ADD A NEW PAIR OF EARS AND HERE'S "TOWSER"

WITH JUST A LITTLE MORE WORK YOU CAN CHANGE "TOWSER" INTO "PETER RABBIT"

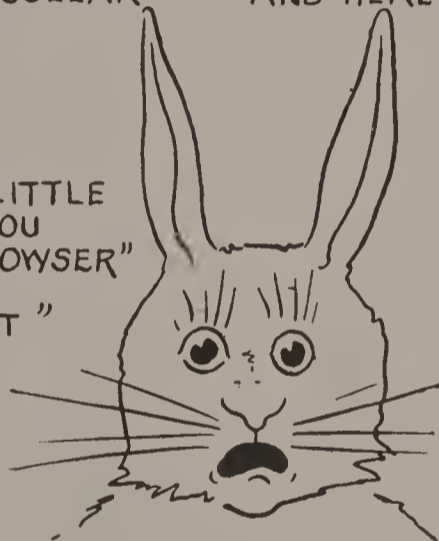

COBB X. SHINN

\$50

THIS cartoon is dandy for you to draw on your little blackboard, because it is easy for you to erase on a blackboard. You can make it on paper just as well if you have no blackboard. If you like, you can make three separate cartoons, one of the "Funny Old Man," then another of "Towser," and still another of "Peter Rabbit."

DRAW AND CUT OUT A "PIGGY" THAT WILL STAND ALONE

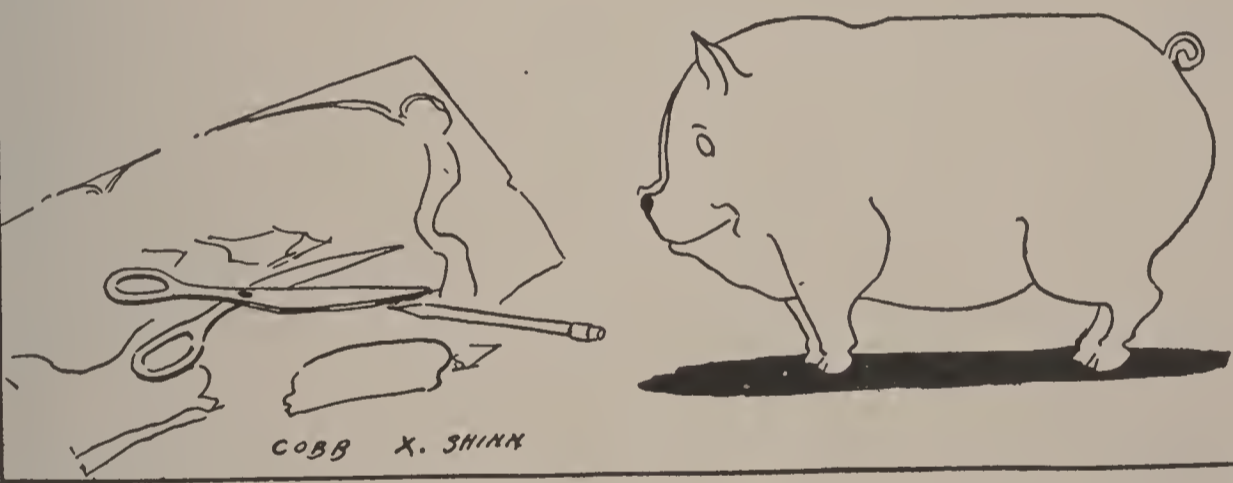
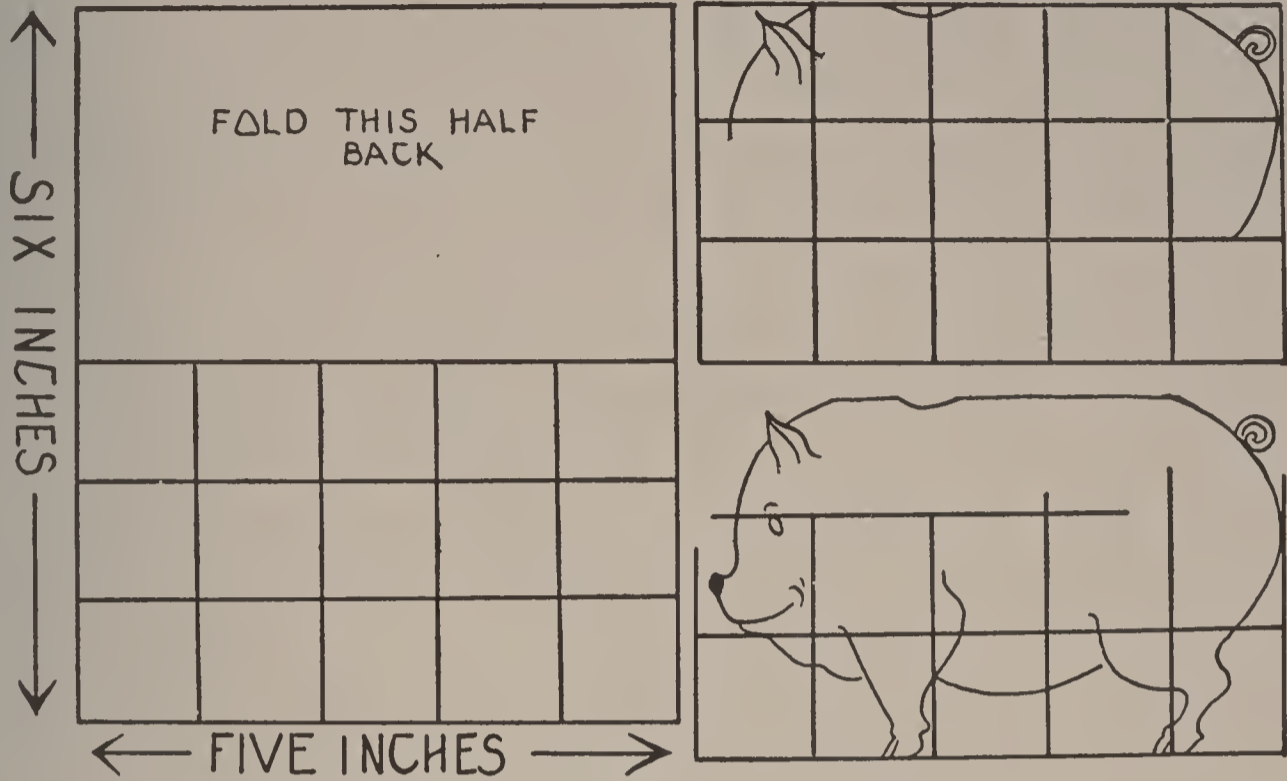

THE drawing of the pig is very easy if you just would use this system of making one-inch squares. So now find your paper and pencil and make your fingers get busy and make the drawing. Then mother will be glad to loan you her scissors to cut out Mr. Piggy.

FUNNY ANIMALS THE A B C's WILL MAKE

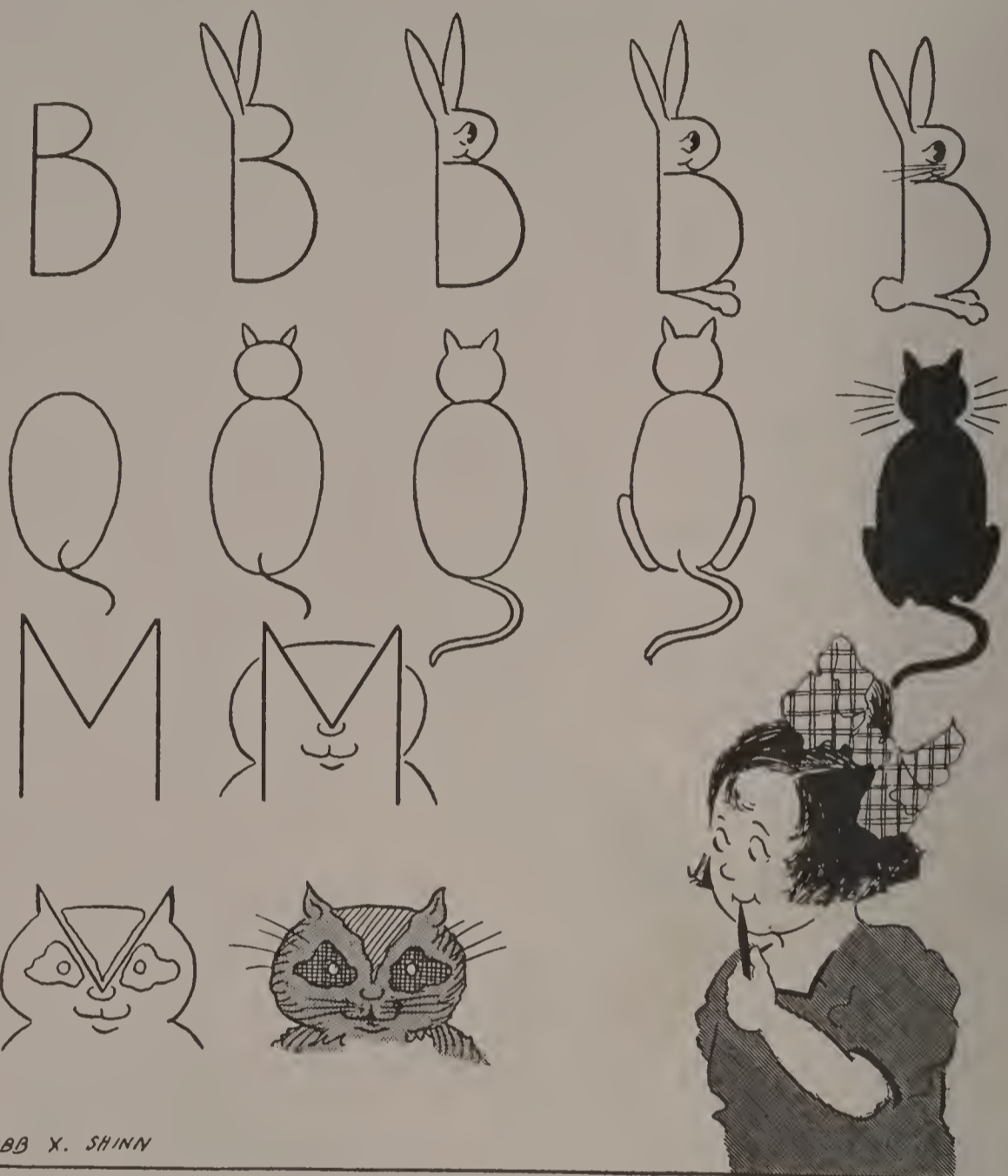

AFTER you have made these funny little animals, try and see if you can think of some other animals that can be made out of letters. There must be many more for there have only been three letters used here out of all the alphabet.

A STORY PICTURE

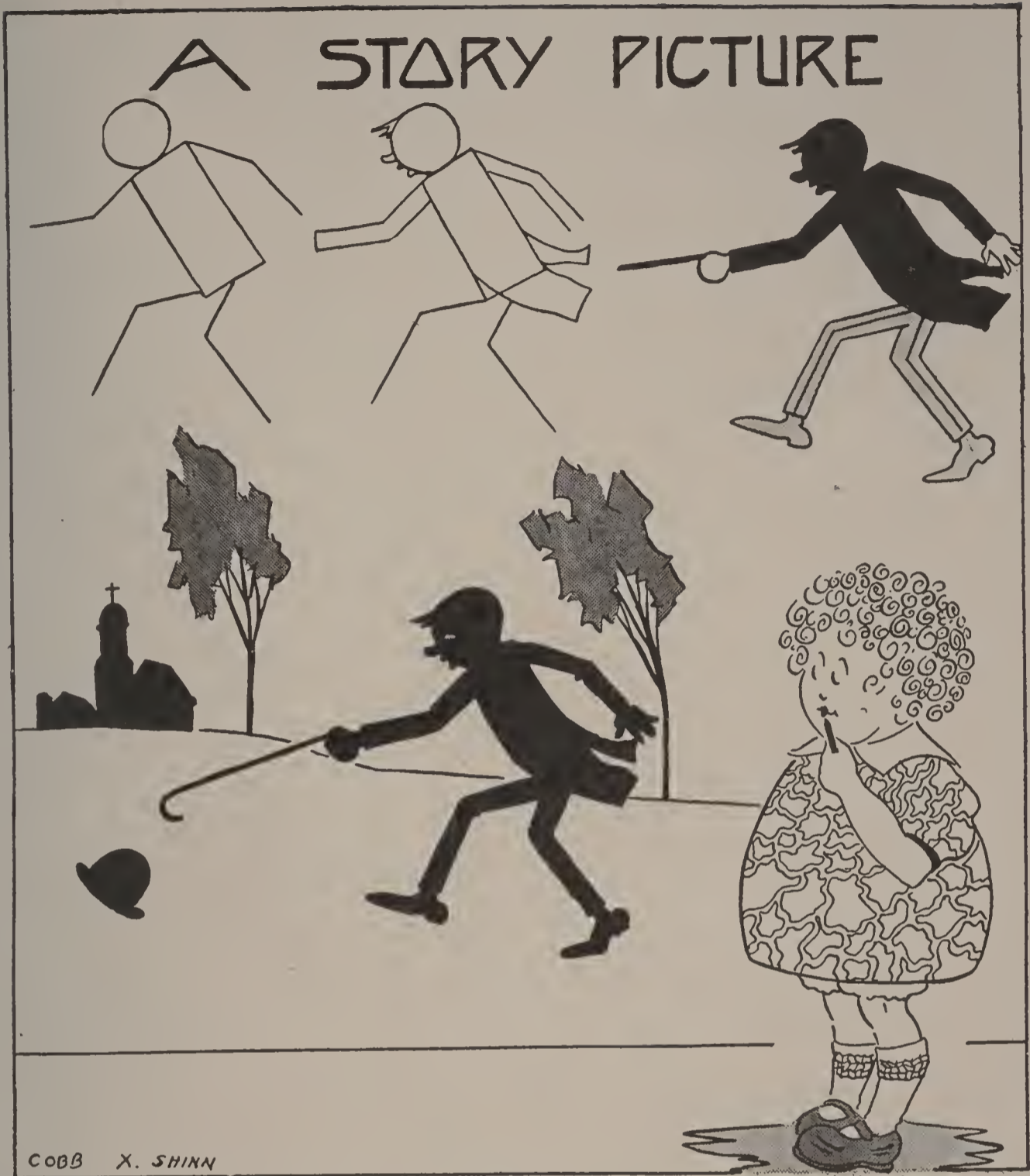

A STORY Picture is always interesting; there are so many different stories that you can tell. These little figures are not hard to draw if you will just follow this system of making them in outline first. Try making this picture and if you want to make it tell a different story, why place a dog where the hat is and you will have a man trying to catch his dog.

LITTLE BY LITTLE YOU TURN A HEART INTO A BOY

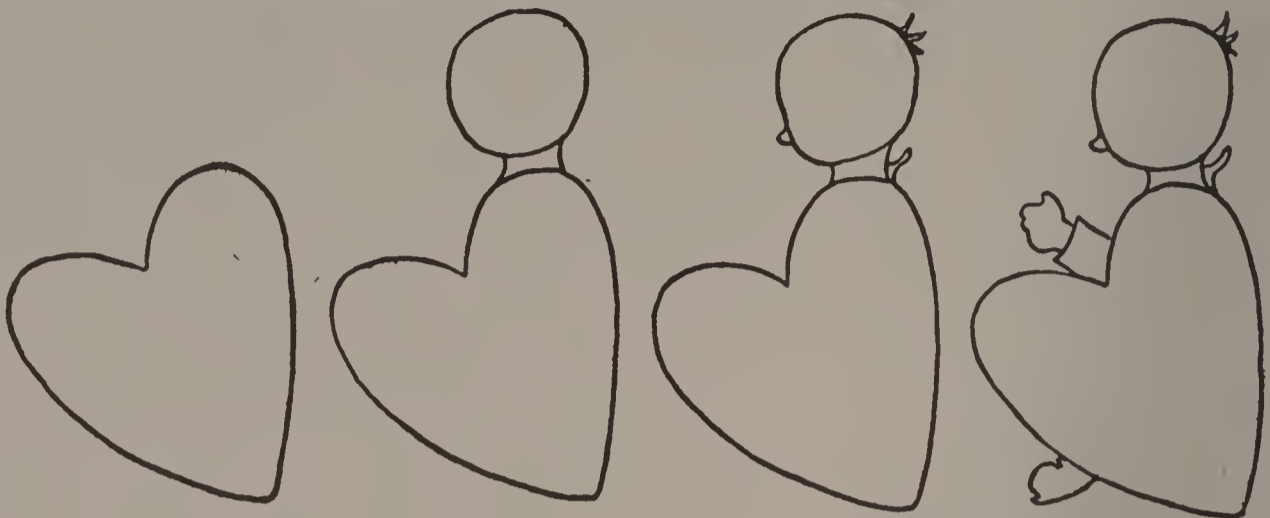

GODD X. SAUND

FATHER will tell you, "Make a good start and you have the work over half done." So be sure and get the heart just about the same shape as the one in the picture. Then little by little to add to it, until you erase the bottom part of the heart.

THE SUNBONNETS



EVERY little boy and girl has read stories about the Sunbonnet Babies, but did you ever think that you would be able to draw pictures of them? And it is so very easy to do it, if first you draw a cone, then place a sunbonnet on the cone. Now you are ready to add the arm and feet. You can make the dresses any color and with most any kind of flowers on them.

“JACKIE”

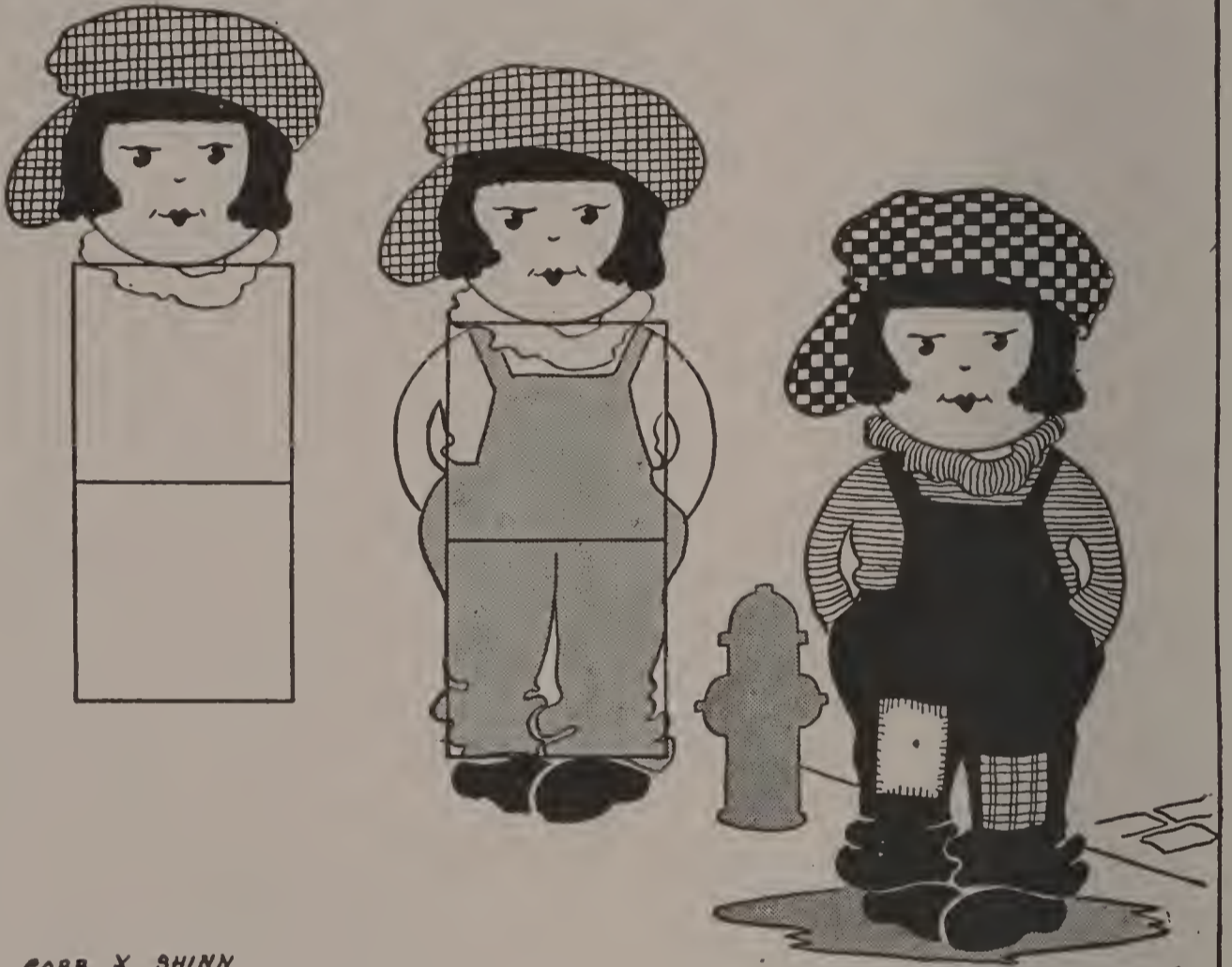

COBB X. SHINN

EVERYBODY knows and loves this Famous Little Movie Actor, so that is the reason he should make one of the most interesting drawing lessons that has been printed. So get your pencil and paper and see what a fine drawing you can make of Jackie.

THE EASY WAY TO DRAW

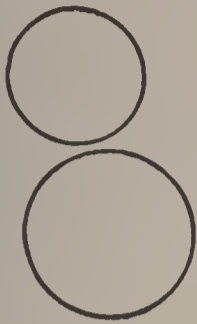

COBB & SHINN



THERE is no need to tell you who this jolly man is that you draw by starting with two circles, one of them just a little smaller than the other. When you have all the features placed on the two circles, then you draw a pear and from the pear you make a pair of pants.

AMERICA'S MOST HANDSOMEST MAN IS EASY TO DRAW

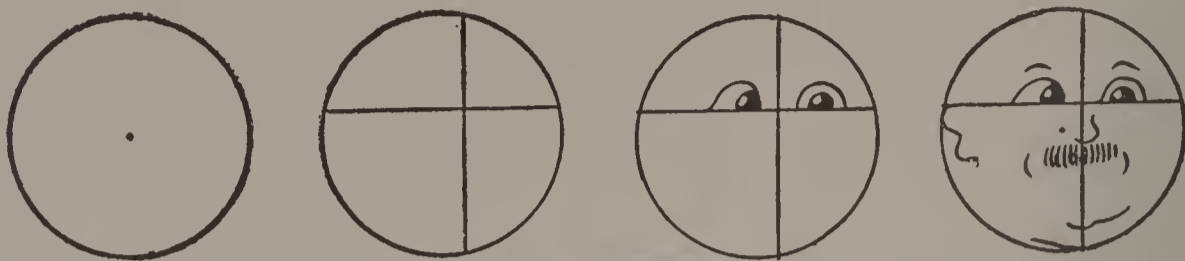

COBB X. SHINN

ALMOST everybody has seen this funny man, "Ben Turpentine," in the movies. But did you ever think that you would be able to draw a picture of him? As you can see, it is very easy to do, if you will just follow the little system here.

WILD BILL THE COWBOY

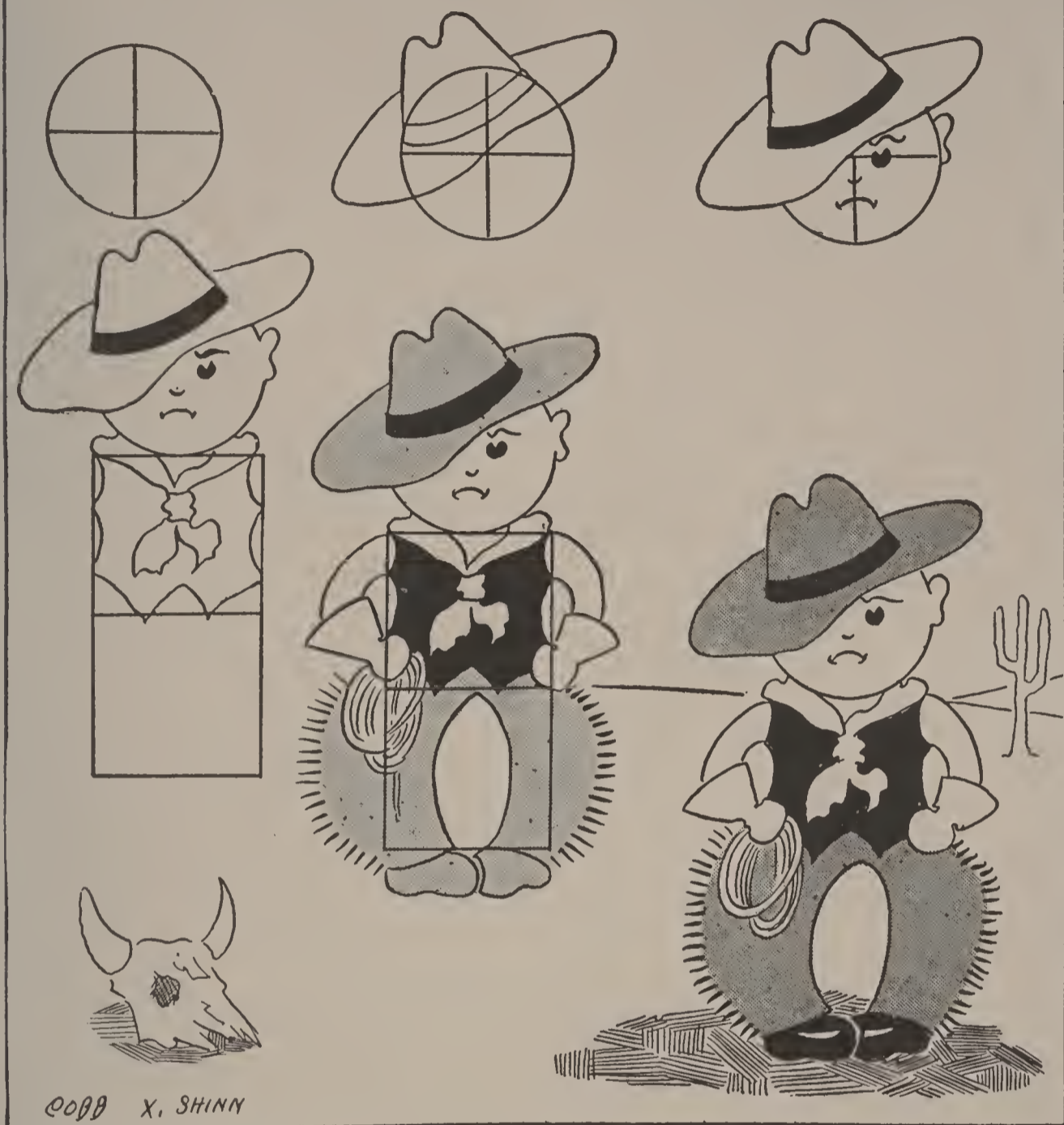

©000 X. SHINN

DO YOU want to draw a picture of Wild Bill, who is so bow-legged that he could not stop a pig in an alley? First you draw a circle and place a hat in it, then give him one eye, for the other one is covered up. Add an ear, nose and mouth. Now place two squares just under the circle; each square must be the same width as the circle with which you made his head.

HEAD BIG INJUN!

FOR THE
LITTLE ARTIST
TO DRAW

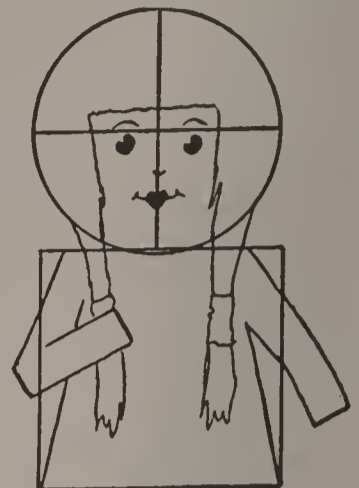
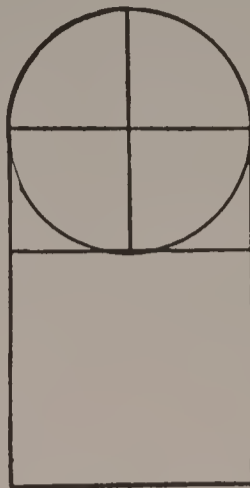

JUST look at what you can make out of two squares and one circle! Now don't say that you can't do it, just get yourself a pencil and some paper. Then make those little fingers of yours get busy.

"LITTLE JACKIE" WHO SAILS THE SEVEN SEAS

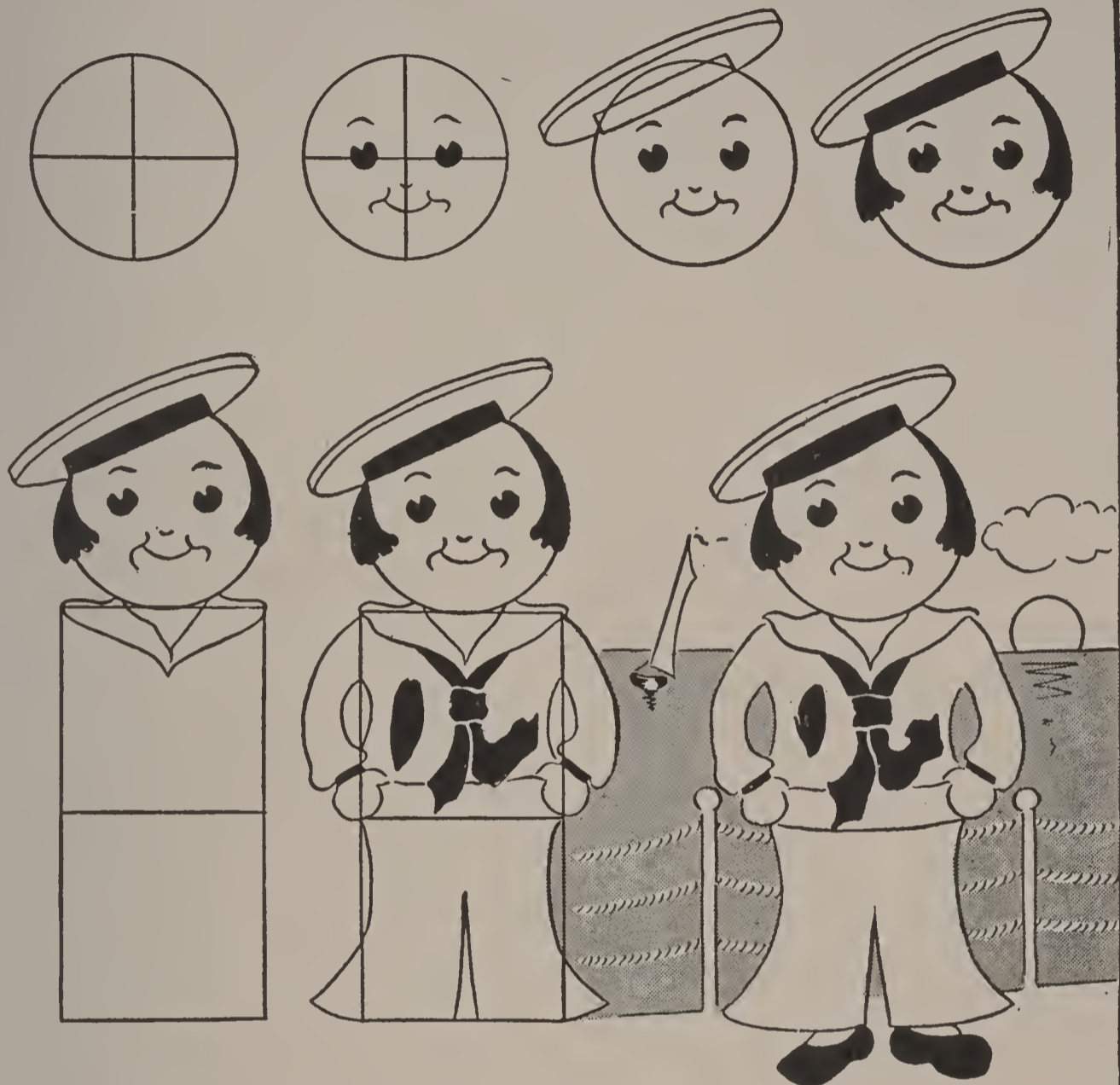

CORB X. SHINN

IT IS useless to try to tell how to draw "Jackie," for it is just as plain as the nose on your face. By this little system you should be able to draw Jackie just as good as the artist that made this picture.

HILDA from HOLLAND

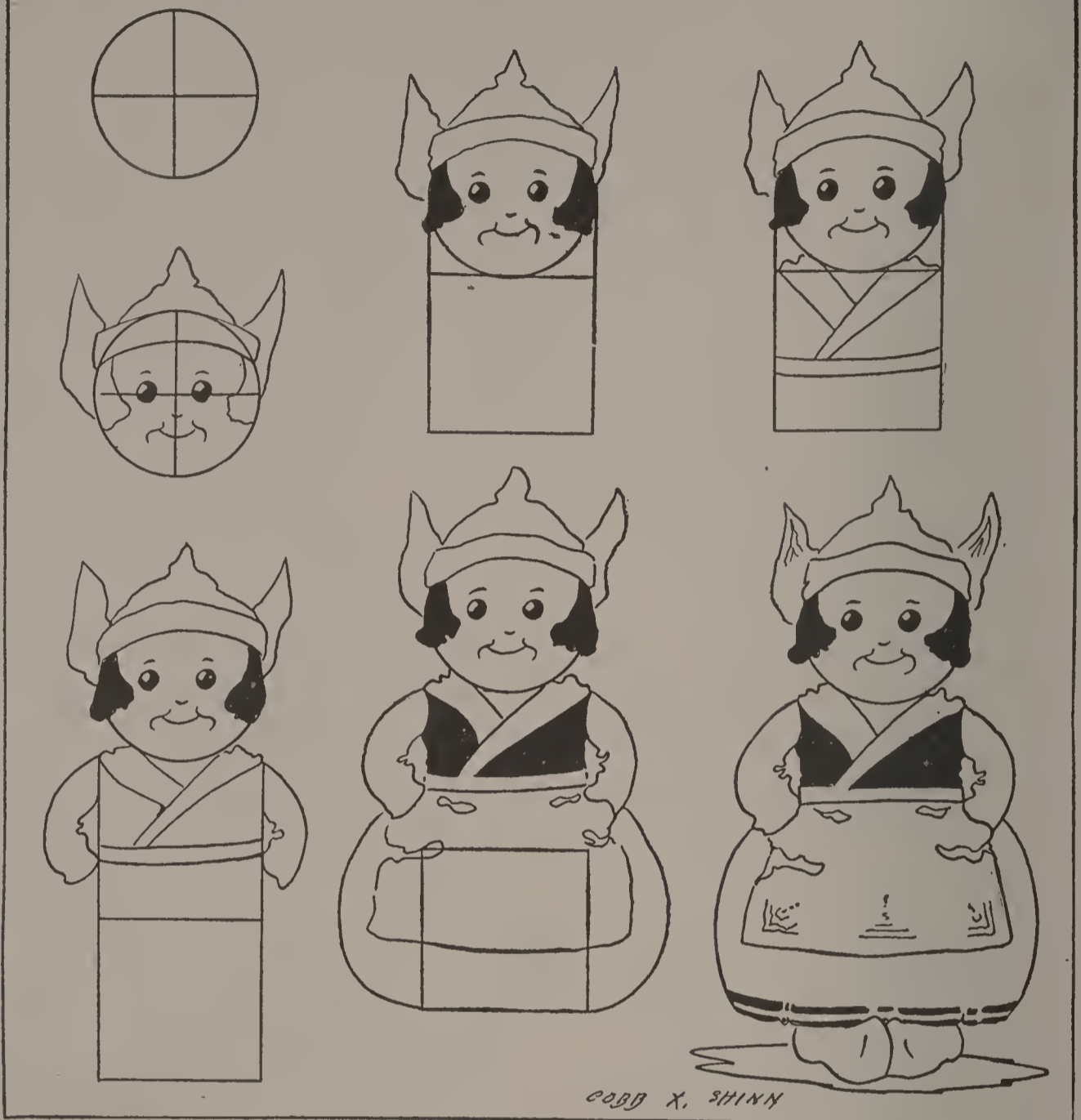

© 1950 X. SHINN

FIRST, you draw a circle about three inches wide. Then fill in the features of the face. Just below the circle make a square the same width as the circle. Now fill in the waist and collar. Then add another square just the same size as the first square. Now you are ready to make the arms and skirt. Don't forget to put on the funny wooden shoes.

"HAPPY" FROM HOLLAND



COBB X. SHINN

"HAPPY" is very easy to draw if you will just make a vase, then place a circle in the vase and another smaller circle on top of the first circle. Then you are ready for the features of the face. His clothes are not hard to do, even if they are so different from the clothes that you wear.

ALEX FROM EGYPT



ALEX'S clothes are very different from your clothes, but you will find them very easy to draw. Just follow this little system that the artist has made here and in a few minutes you can make a dandy picture of this Jolly Little Black Fellow from Egypt.

Pirate Pete

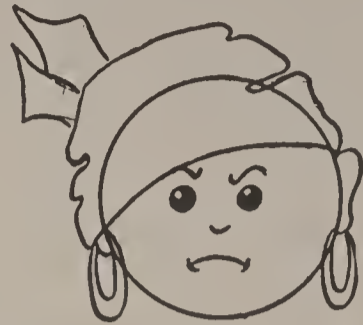
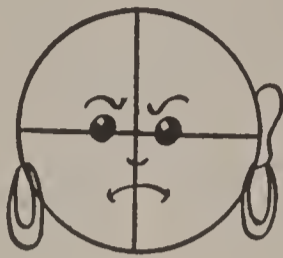

COBB © X. SHINN

THE only place that you ever get to see Pirates is in the movies. And you can read about them in story books, but did you ever try to draw the picture of one? Now here is about the best chance that you will ever have to draw one. It is very easy to do, so make your little fingers get busy with your lead pencil.

THE EASY WAY TO DRAW A LOCOMOTIVE

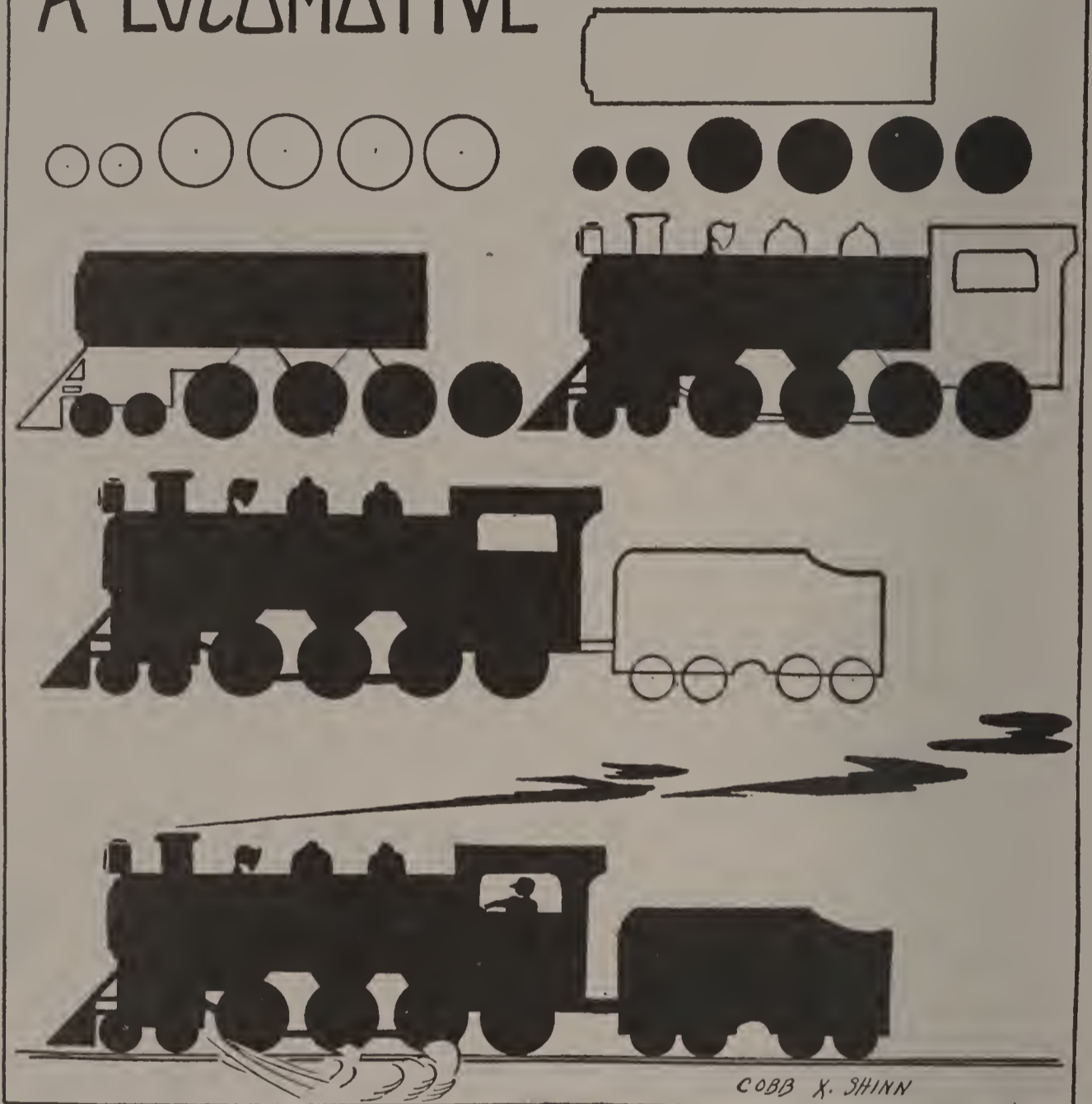

AT FIRST a Locomotive looks very hard to draw, but if you use a ruler and compass you will find it very easy to draw. Of course, you have to be careful and get the different parts in the right proportions. This is the only difficult part of making a drawing of a Locomotive.

HOW TO MAKE THIS OLD BARN LOOK ATTRACTIVE



COBB & SHINN

CAN you find a shed, barn or fence in your own back yard that you can draw? Then make another drawing of it and improve the looks of it. Have vines to cover the old dead trees or cover the unattractive old fence. Cannas, hollyhocks or other tall flowers planted by the fence will add to the beauty. Large boulders placed along the walk make it more attractive; and don't forget to give the barn a coat of paint.

LANDSCAPE COMPOSITIONS IN LIGHT AND DARK



THE easy way to make Landscape Compositions is to make them in black and white. First of all, draw your sky-line across the paper, then place the largest object in the picture first, like the boat in the top picture or the river in the lower picture. Then the next largest objects, like the Lighthouse or the trees in the lower picture. Then you are ready for the small details like shadows, clouds and birds.

BORDERS THAT YOU CAN DRAW

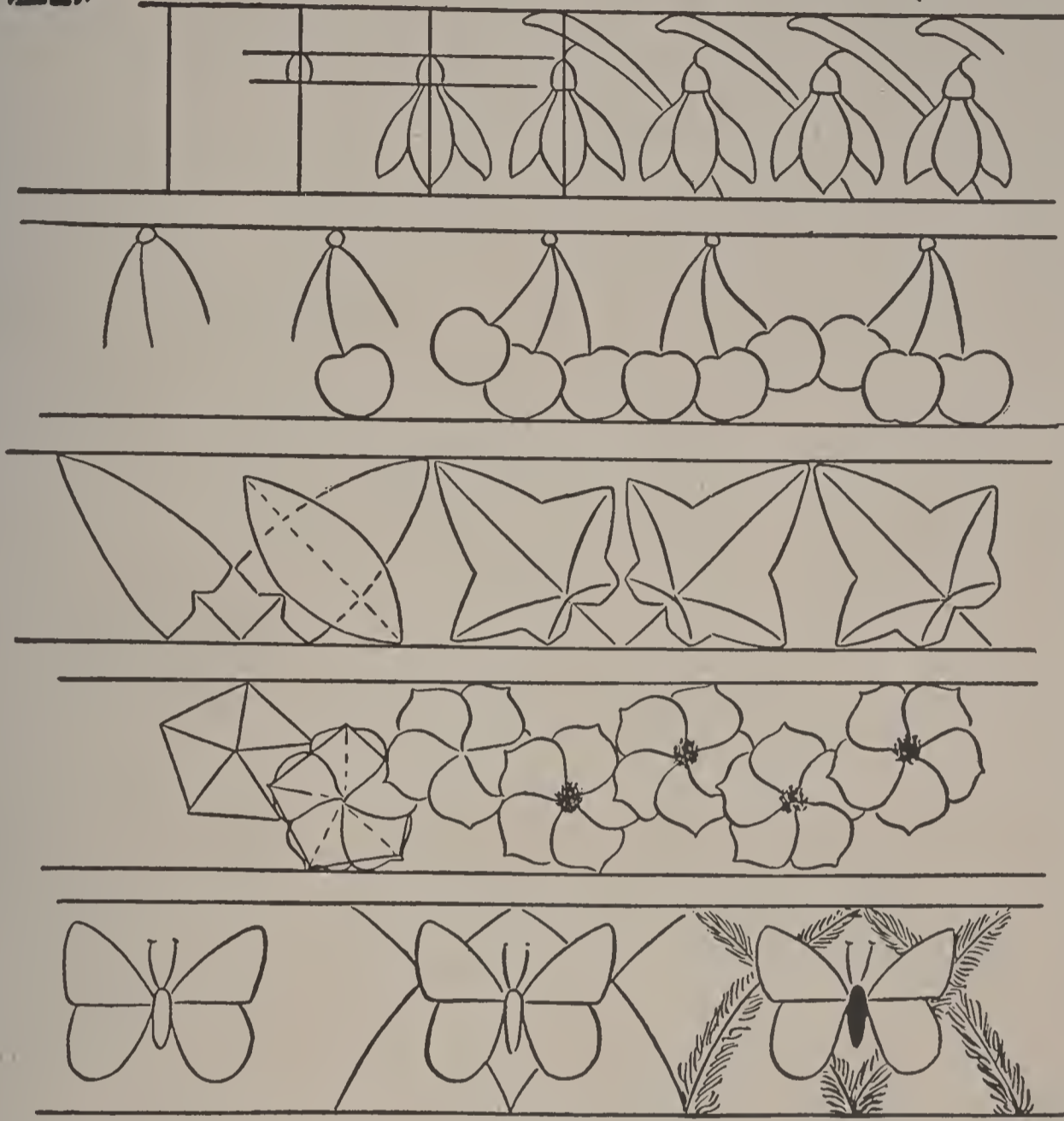

© 1933 X. SHINN

HERE are some dandy borders that you can use on the covers that you make for your school books. They would be very pretty on a lamp shade that you can make out of paper and don't forget to use your water colors to color them. There are any number of things that you can use these borders on.

SOMETHING

TO DRAW
TO CUT
TO PASTE

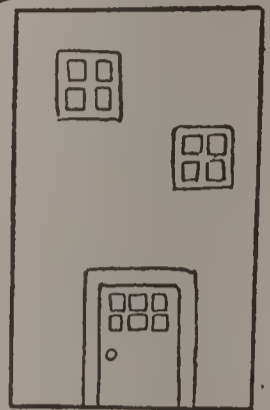
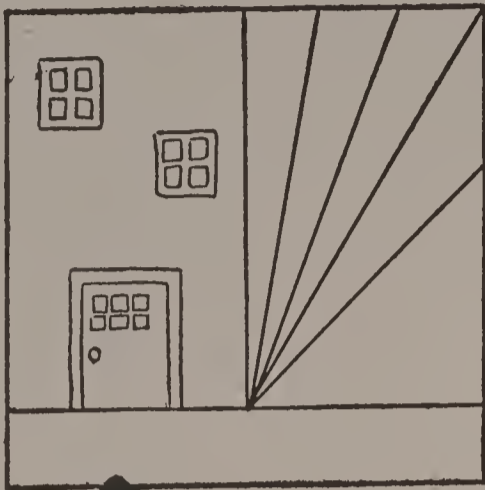

Cobb x SHANN

THE first picture shows you just how to divide the square into seven parts. The next picture shows you how the square is cut into parts. The last picture shows you just how to arrange the parts to make a wind mill.

SHADOW PICTURES FOR YOUR FINGERS TO MAKE

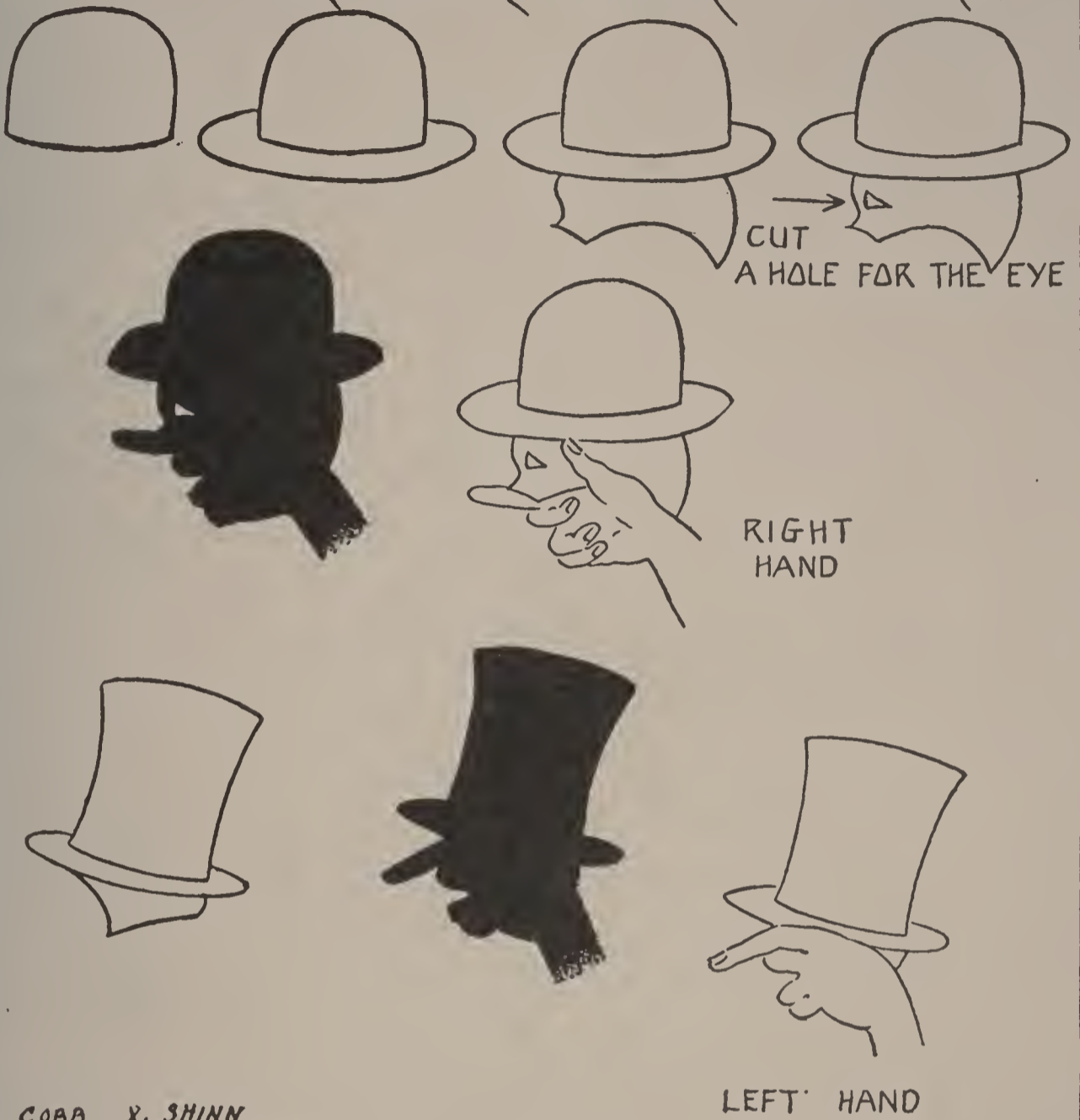

COBB X. SHINN

LEFT HAND

OF COURSE you can make shadow pictures by using fingers, but you can make a lot more different kinds if you will cut out hats for them. Just take a piece of cardboard—it does not have to be very heavy. Make the outline of the hat with lead pencil. Then lay your hand on the cardboard to see if you have the hat about the right size to fit on your hand.

INDIAN DESIGNS

MOUNTAIN



WAVES



CLOUD

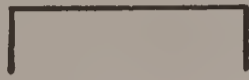

MIST RISING

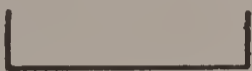

LIGHTNING



HOUSES IN A VILLAGE



A WHIRLYWIND



THE
FOUR WINDS



AN ENEMY HAS
CROSSED OUR TRAIL

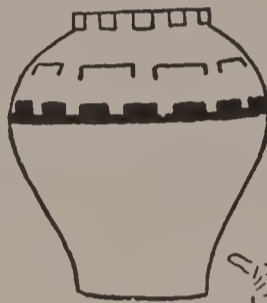
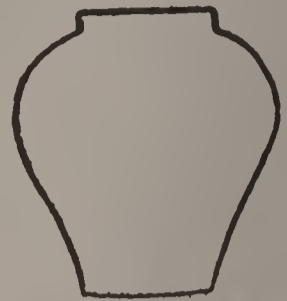

2039 X. SHINN

HERE are some very interesting symbols from Indian Designs. They are very easy to draw. Also they are just the thing to use when you decorate your Indian Suit. It will be very easy to draw or paint them and make your suit look like a real Indian costume. If you like, try drawing a vase and use these symbols to decorate it, making the design tell a story.

IT'S AS EASY AS ROLLING OFF A LOG



PAINT A PEANUT
A BRIGHT BLUE,
YELLOW, GREEN
OR RED



NOW PAINT THE EYES
OR USE WHITE HEAD
PINS ON THE END
THAT HAS THE HOOK



CRAPE PAPER PASTED
ON THE BACK WILL MAKE
THE WINGS AND TAIL



ONE OF DAD'S
PIPE CLEANERS
MAKES A
DANDY PAIR
OF LEGS

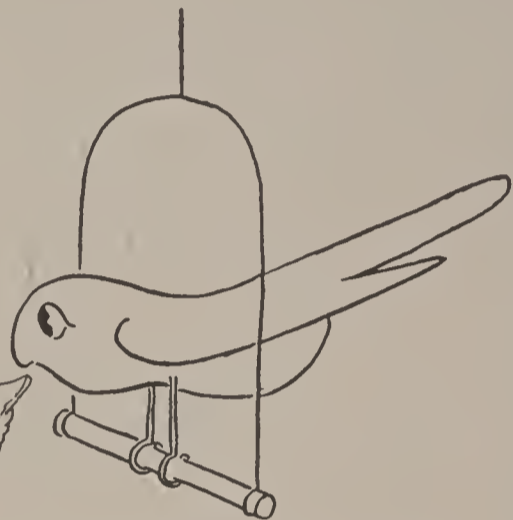

A PIECE OF A PENCIL
AND A LITTLE FINE
WIRE MAKES THE SWING

COBB X. SHINN

IF YOU don't want to make one of these Little Parrots out of a real peanut and crepe paper, you will find it a lot of fun to draw them. Starting with a peanut first, then the eye, then the tail and wings. If you like you can make the parrot a very fancy bird cage.

YOU CAN MAKE THEM PEANUT BOYS AND GIRLS

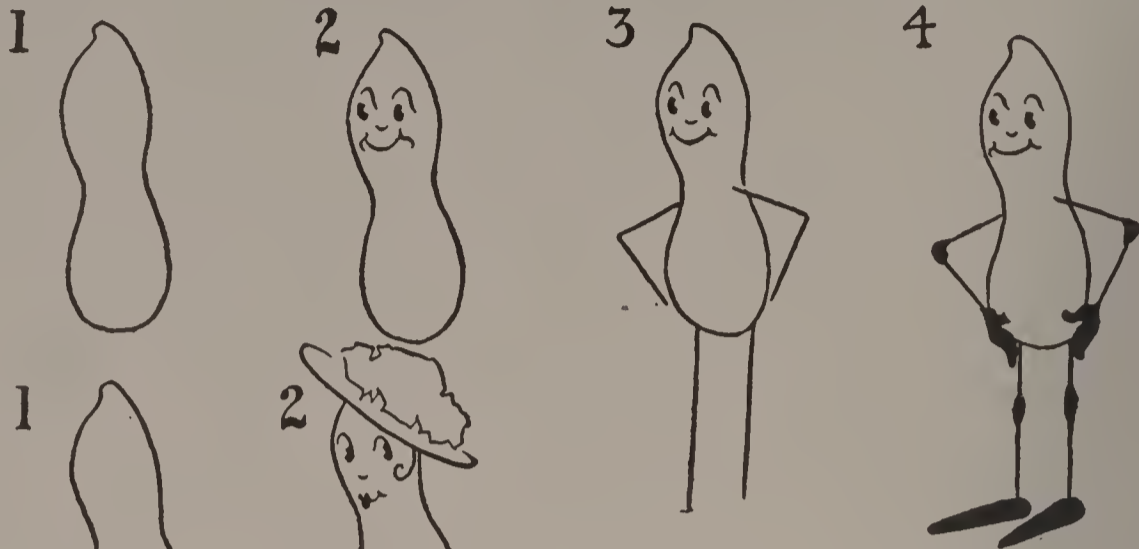

COBB X. SHINN

THE next bag of peanuts that you get, just place one of them down on a piece of paper and then draw a line around him. This outline will make his body and it is very easy to fill in the features of the face and place legs and arms on them. Or draw the eyes and mouth upon the peanut, make his arms and legs of toothpicks and the hands and feet of modeling clay.

FUN *with* TANGRAMS



HOW TO CUT TANGRAMS
FROM A SQUARE PIECE OF PAPER



A BOY RUNNING



A SAIL BOAT



A CANDLE STICK



COBB K. SHINN

IN CHINA, many centuries ago, the first "Tangrams" was designed. Any child can make them by taking a square and cutting it up into seven pieces as shown here in the picture. Cut up three or four squares of black paper of different sizes. These will make enough pieces for you to make animals, birds, fishes, flowers or most anything that you wish.

THE TRICK OF MAKING A PAPER BOX

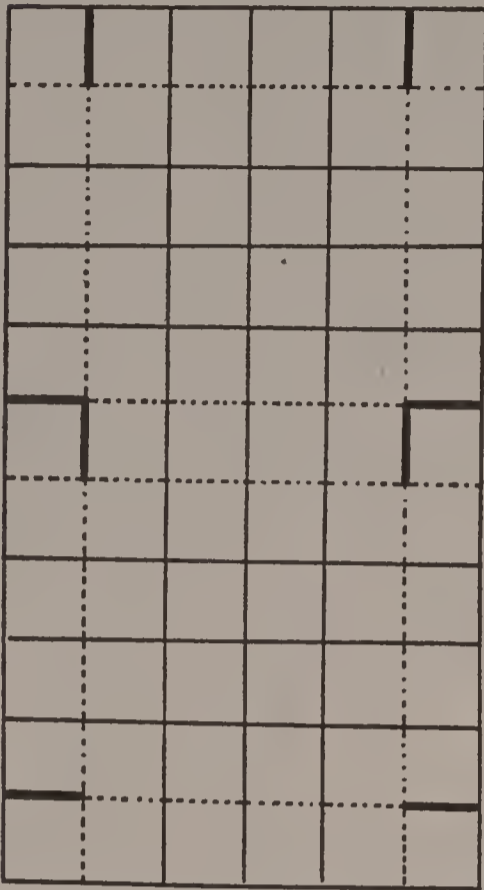

CUT ON THE HEAVY LINES
AND
FOLD ON THE DOTTED LINES

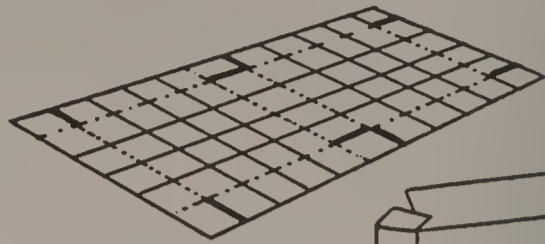

FOLDED

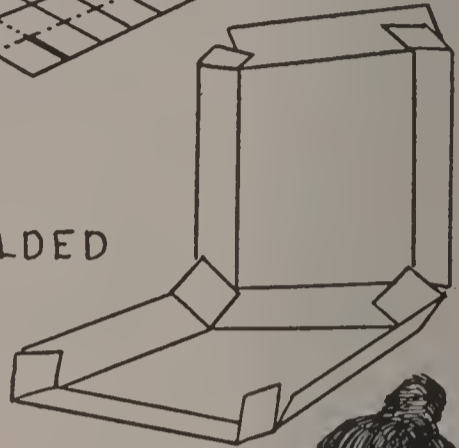

PASTED

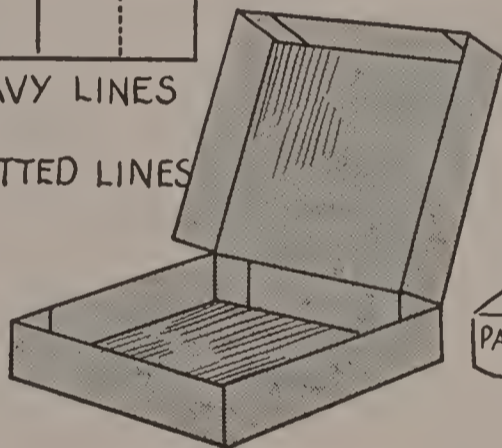

COBB X. SHANN

ALL THAT you need is a piece of cardboard or heavy paper, a ruler, a sharp pencil and scissors. Mark off a space eleven squares long and six squares wide. Take the scissors and cut where you see the heavy black lines. Then fold your cardboard where you see the dotted lines. Then you are ready to paste the corners and have the box completed.

A BOOK PLATE



EVERY little boy and girl has a book that they do not want to lose and if you make a book plate for it you would almost be sure of not losing it. It is very simple to make by starting with a circle.

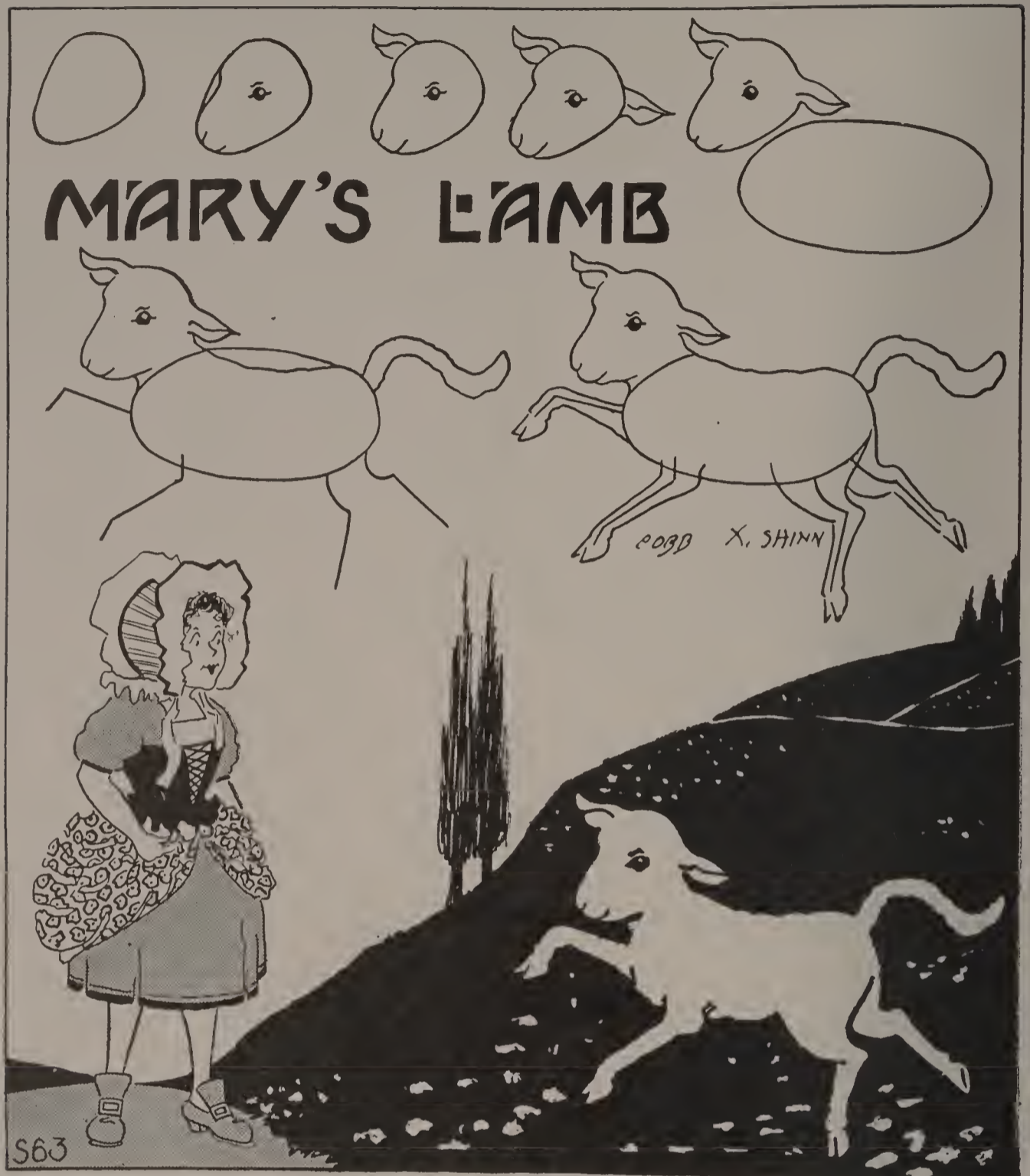

THE more you practice your music lessons the better you can play. The same thing is true of drawing. Don't just make one picture of Mary's Lamb, make a dozen of them. Then try making another dozen. When you compare your first drawing with the last, you'll be sure to see that you have made some improvement.

RED RIDING HOOD IS EASY FOR YOU TO DRAW

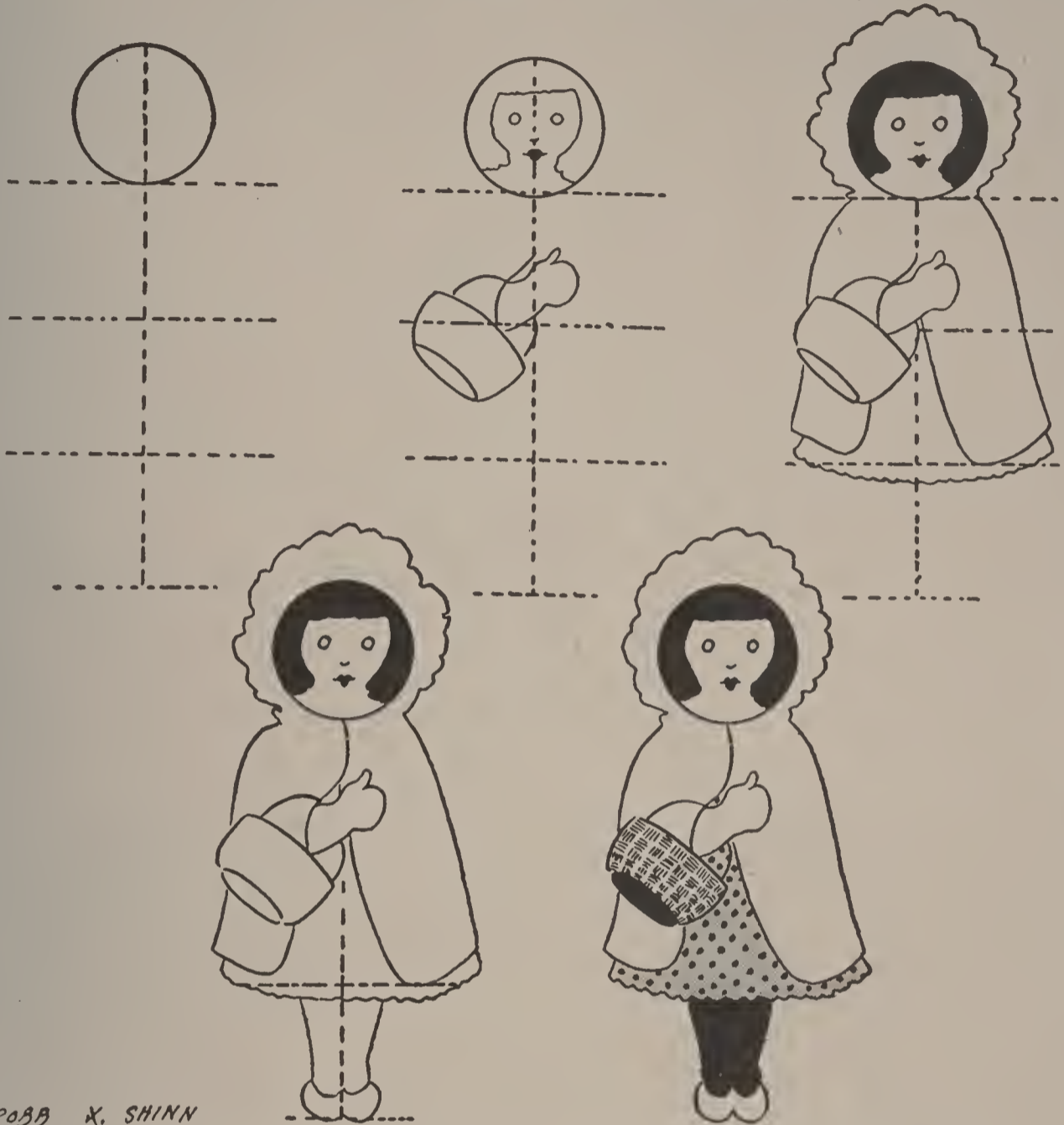

OF course every child knows the story of Red Riding Hood almost by heart, but who can draw and color up a picture of her? It is very easy to do, just divide her in four equal parts. By this little system you can make a fine pattern for a rag doll, first make it on paper and trace it off on to muslin.



FIRST you see an oval and a circle. Put that down on a piece of paper. Next you see a nose, an eye, and a pair of ears on the circle. You see four legs on the oval. When you have them all down on a piece of paper you have a picture of the pig that Tom the piper's son stole.

PUSS IN BOOTS



EVERY boy and girl has read the wonderful fairy story of "Puss in Boots." Do you remember how the cat started out with a sack on his back and won fame and fortune for his master? This drawing is a picture of this wonderful cat. It is so easy to do if you will just follow this little system of circles. Try it and see how well you can draw.

AN EASY WAY TO DRAW A FUNNY BUNNY

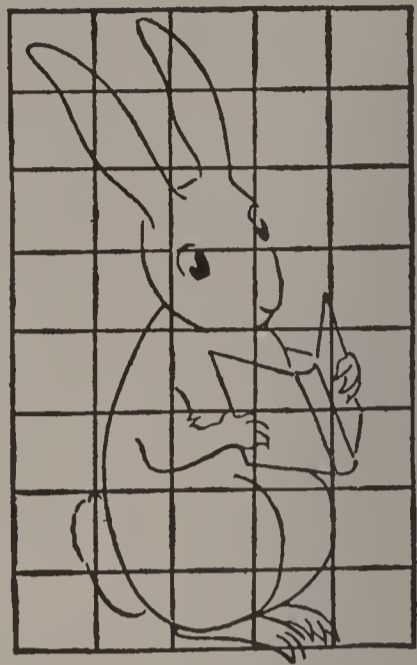
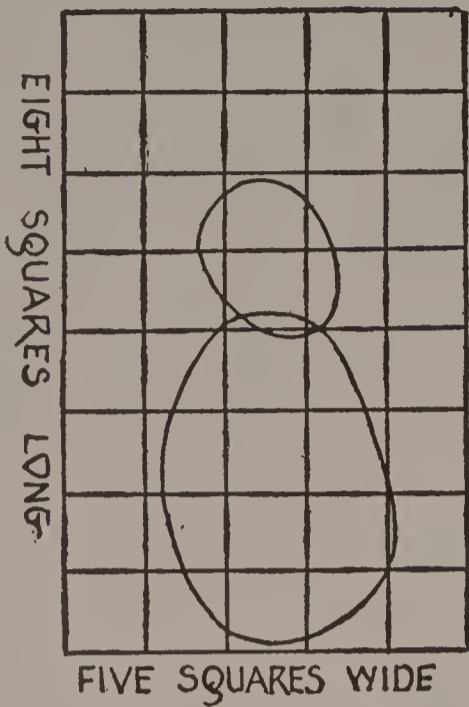

POBB X. SHINN

TAKE a piece of paper and mark off a space eight squares long and five squares wide. The squares can be any size you want to make them, but be sure they are square. You then will find it very easy to draw the Funny Bunny. For you can see just what part of him goes in each square. This way you will not get his ears too long or too short, but just right. And so on with every part of the Funny Bunny.

THE RABBIT THAT LOVES TO SWIM



copy X. SHINY

THE Marsh Rabbit that lives down in the southeastern part of the United States, loves to swim. When he is alarmed he runs for the nearest water and plunges in and hides under the different water plants, with just his nose and eyes out of the water.

SNOWY BALL *the* ARCTIC HARE

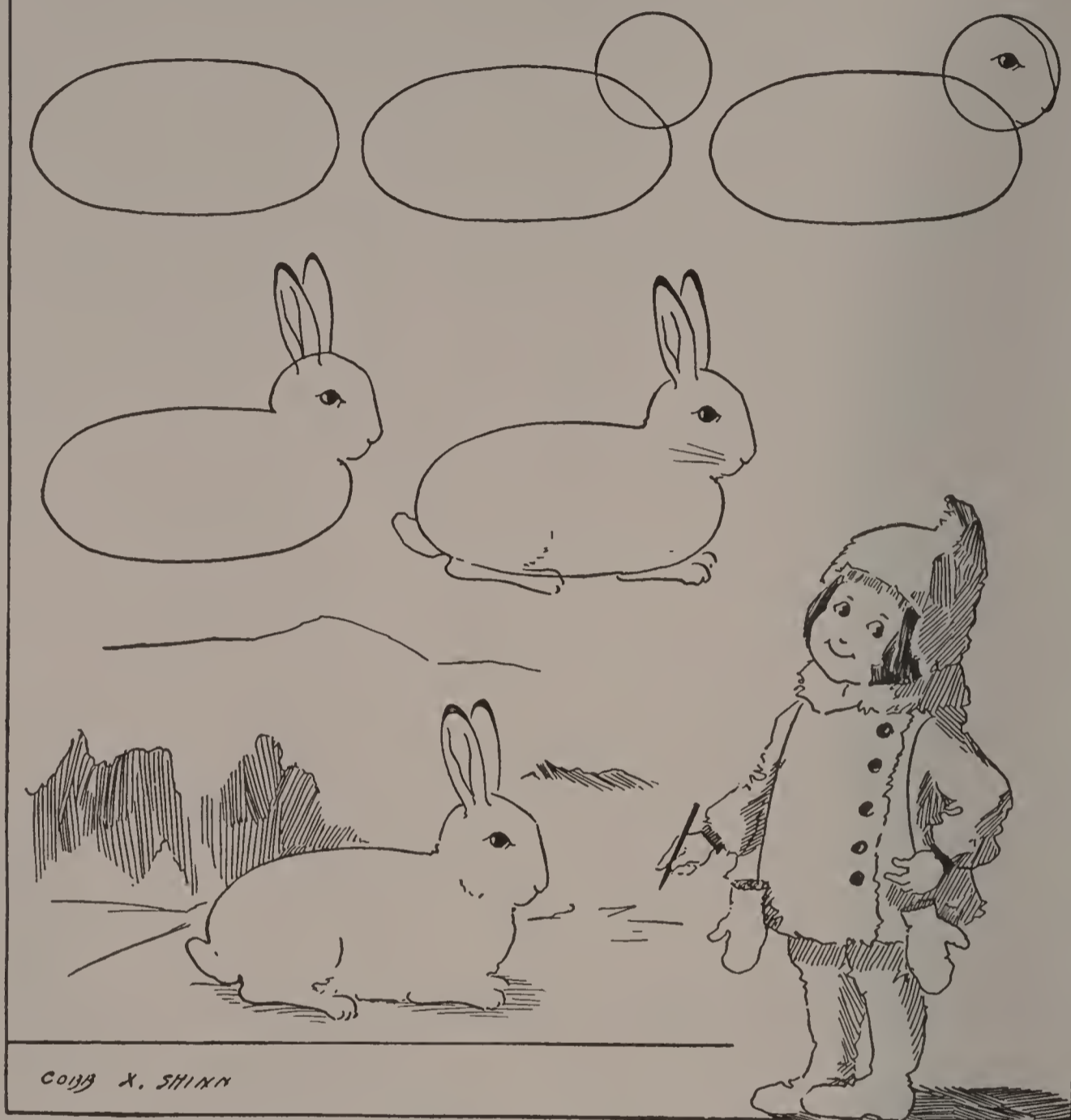

“**E**VERY story you read is about Peter Rabbit,” said the Little Eskimo. “Snow Ball is just as interesting as Peter Rabbit and by far more handsome a fellow than Peter. But he does not have so many friends for he lives far up in the Frozen North. He has a wonderful coat of fur, which is snow white except the tips of his ears and they are black.”

“LADDIE”



OF course you have seen many Airedale Terriers. But here you have a chance to draw a picture of Laddie with your own little fingers. So now you had better get your drawing paper and pencil and see how easy it is to draw a picture of this faithful pet.



HERE'S THE EASY WAY TO DRAW A DOG

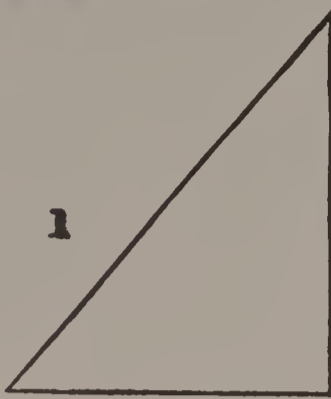

1

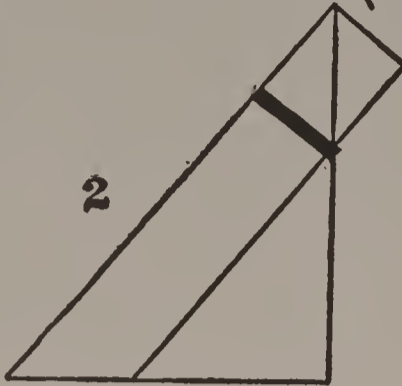

2

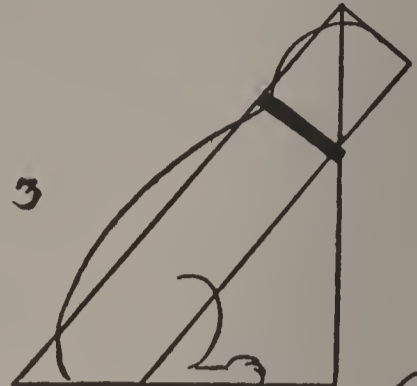

3



4



5



6

POBB X. SHIND



IF you feel that you are not very clever at drawing, try making a picture of this dog. You will be surprised at the pleasing drawing that you can make. First making a triangle and then follow this system.

A PONY THAT YOU CAN DRAW

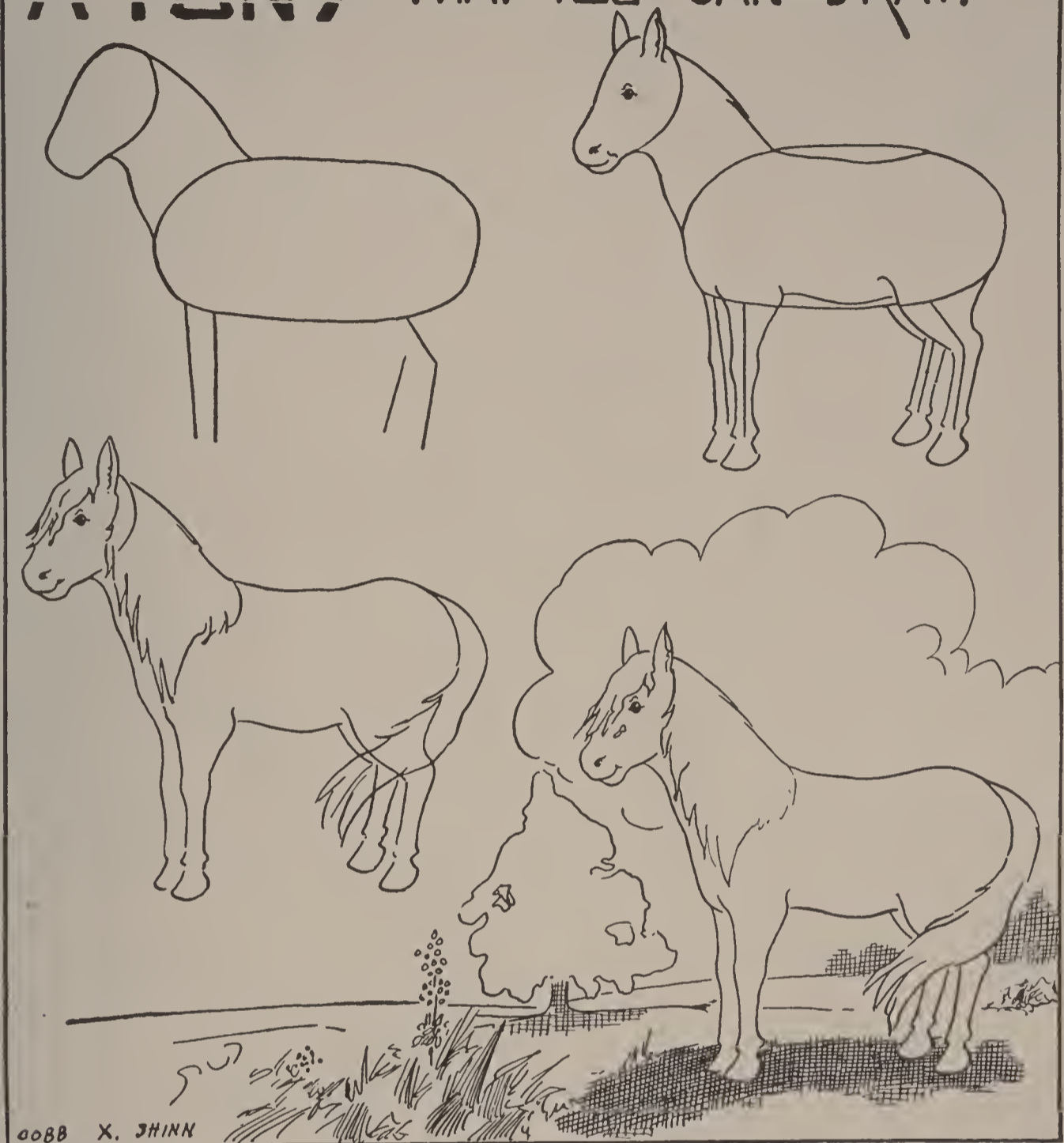

0088 X. JHINN

THERE never was a boy or girl who did not want to own a pony, but so very few of them ever do. Now there is one thing sure, that if you can't own one, you can draw the picture of one. By this little system of drawing you will find it very easy.

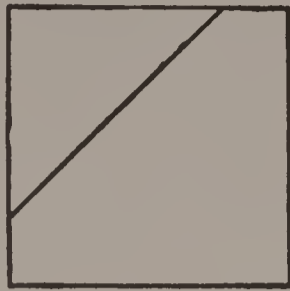

The **EASY WAY** to **DRAW**
a
JIM DANDY
PICTURE



BILLY
GOAT

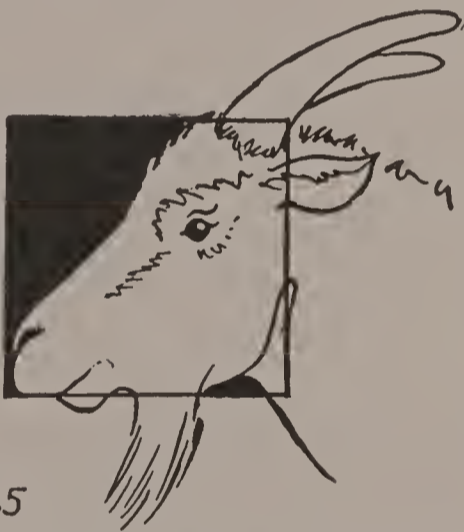

S65

FIRST you make a square, then triangle off the upper left hand corner. This gives you a big start on the drawing of Billy Goat. Draw in the nose and mouth, then blacken the triangle part of the square. Be sure to get the eye in the right position. Draw the ear and the whiskers and then the horns. Then you will have a good picture of Billy Goat.

CAN YOU CHANGE A TOP INTO A GOAT?



IT is just as easy to draw a picture of a top as it is to draw a heart for they are both almost the same shape. So when you have made your drawing of the top it will be very easy to turn it into a goat. Now you had better get some paper and a pencil and make your little fingers get busy. Let your eyes see just what your fingers can do.

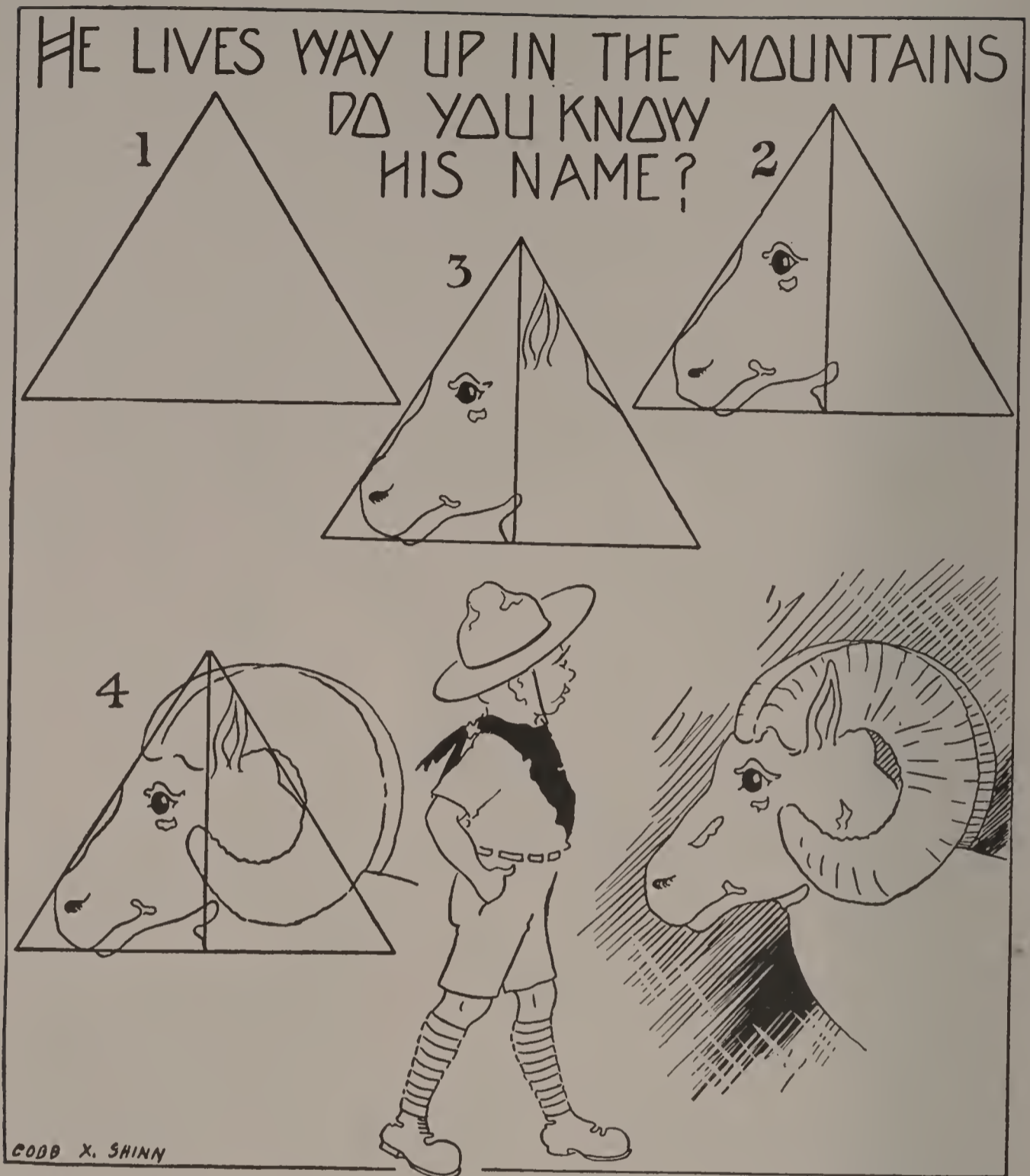

VERY few of us ever have had a chance to see “Bighorn” the Mountain Sheep. For he lives up in the mountains, so high that the tops of the mountains are in the clouds and are covered with snow. Just like any other sheep he has hoofs, but they are the kind that never slip. He delights to bound along the edges of great cliffs where it is almost impossible for man to follow him.

The MONKEY and the CROCODILE

THAT LIVES ON THE BANKS OF THE NILE



A COMPOSITION of words is a number of words arranged so as to tell a story; or the art of forming sentences. A composition in drawing is arranging a number of objects so that they will tell a story. You can tell just what the crocodile would do if the monkey gets close enough—the picture tells a story.

HE IS BILLY GOAT'S COUSIN
DO YOU KNOW HIS NAME?



COBB X. SHINN

THIS cousin of Billy Goat lives high among the rocks and slopes of the Rocky Mountains. For this reason he is called the Rocky Mountain Goat. He wears a great long coat of shaggy white hair and his shoulders are humped up somewhat like those of a buffalo. His horns are much smaller than our common goat and are black.

REDDY FOX

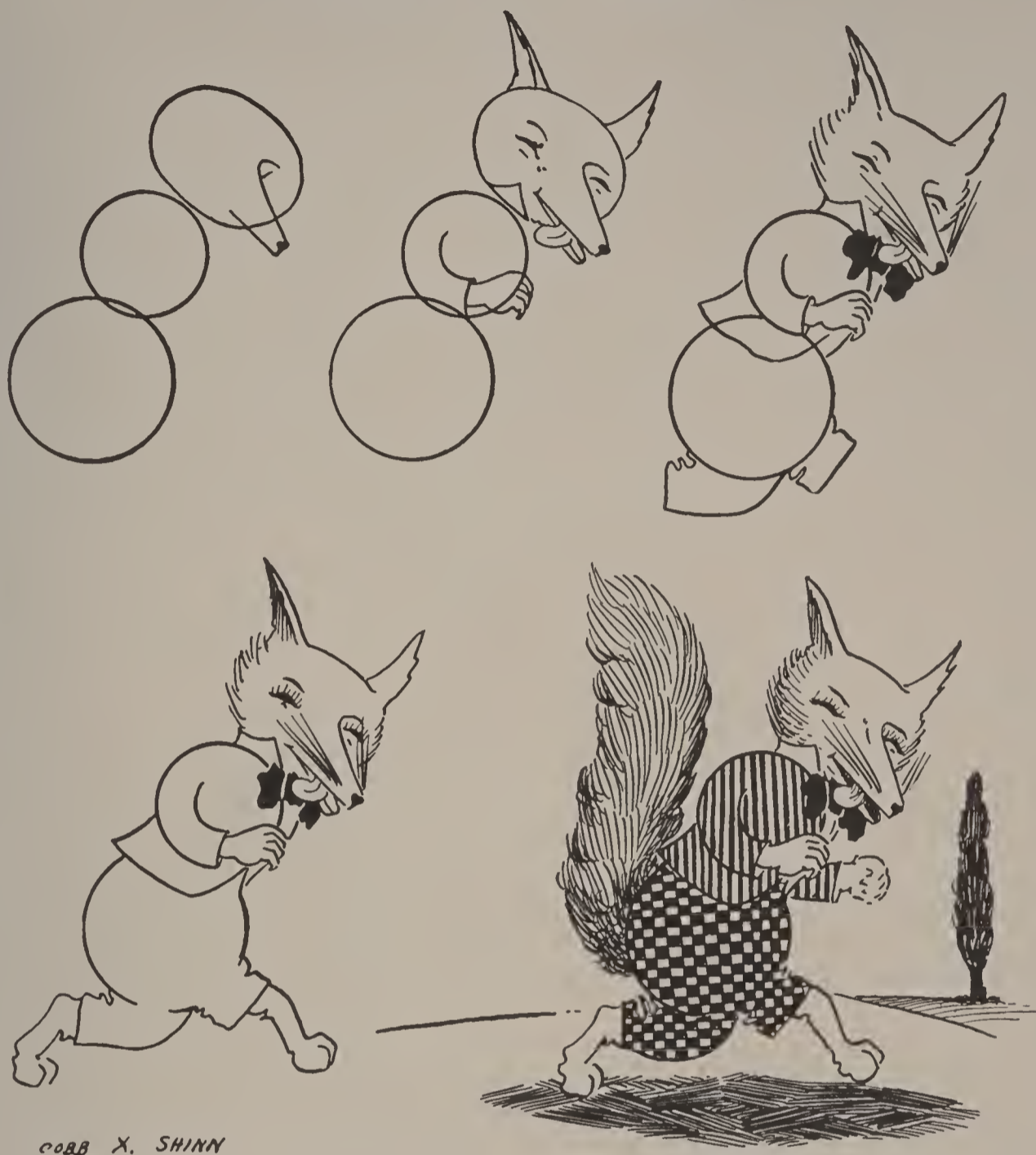

COBB X. SHINN

EVERYBODY knows "Reddy Fox" for he is always the bad one in the Animal story books. Not only does he steal chickens in story books, but also in real life. He is the biggest thief that Farmer Brown ever has to come around his barn yard. Now let us see just how good a picture that you can draw of this cunning little fellow.

THE EASY WAY TRY IT

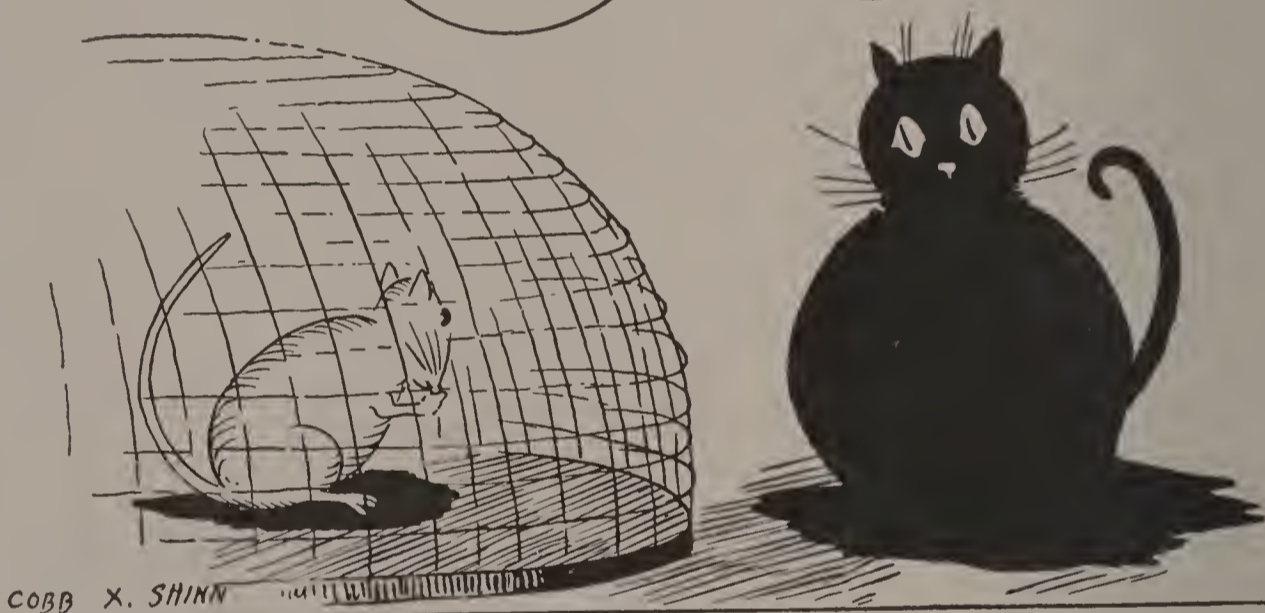

DRAWING is the only language which everybody can understand, so that is the big reason why everybody should learn to draw. There are so many little tricks about drawing that it will make it very easy for you to do. Here are just two of the many tricks and these two tell a story that it would take many words to tell.

MOTHER CAN MAKE THE SHADOW
AND YOU CAN DRAW AROUND IT



PETER RABBIT

REDDY FOX

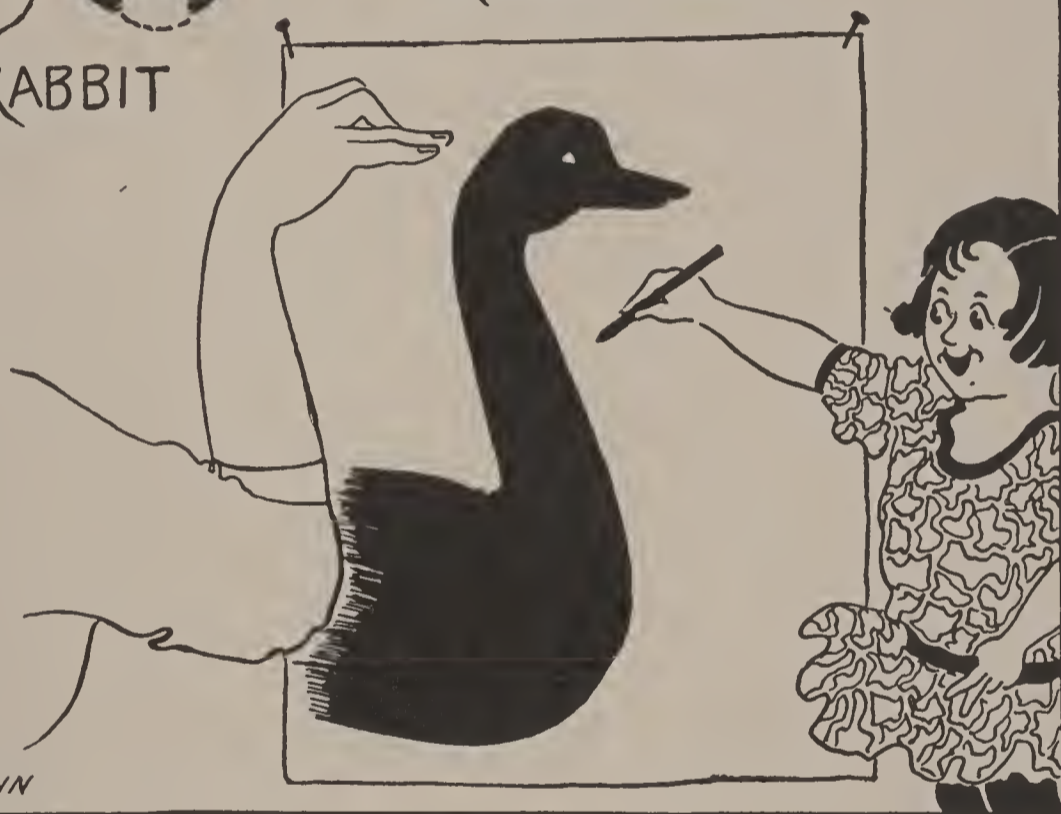

COBB X. SHINN

THIS drawing lesson is somewhat different from the others that you have had, you will have to get father or mother to help you. Just take a piece of wrapping paper and pin it on the wall, then have father make these shadow pictures with his hands. Then you take a pencil and draw the outline of them on the paper.

The HANDSOME LITTLE BEACH MOUSE

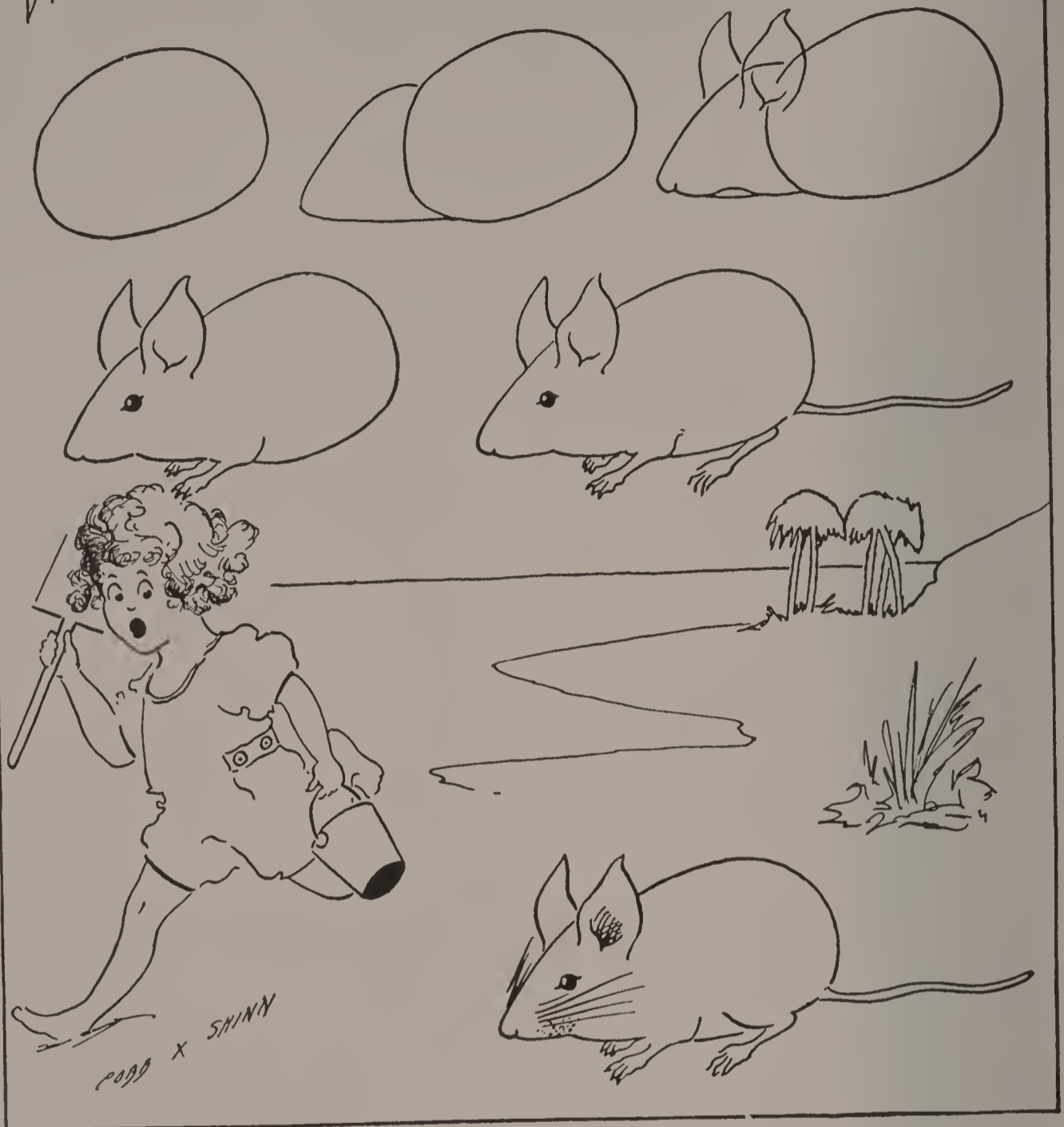

HE is a beautiful, velvety-furred little creature about the size of a house mouse. His back is a very delicate shade of light tan and his stomach and feet are snowy white. You find the Handsome beach mouse along the coast of Alabama, Georgia and through a large part of Florida.

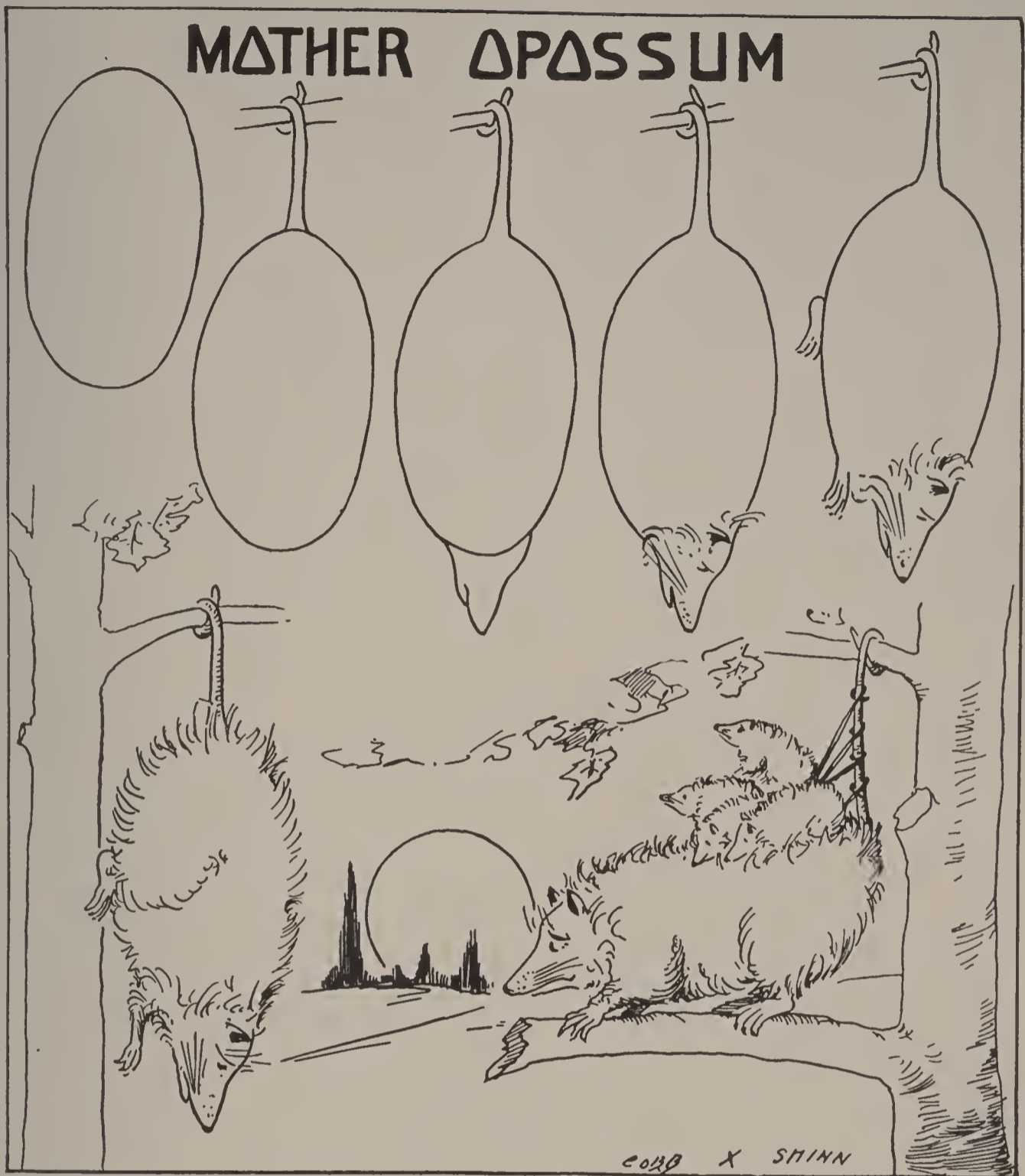

THIS little animal called opossum is about the size of a cat and is noted for being very cunning. It has a very long tail which it likes to hang by, head down from a branch. Of course you have heard of "Playing Possum" which means playing dead, the opossum does this.

THE ONE ANIMAL WHO HAS NO FRIENDS

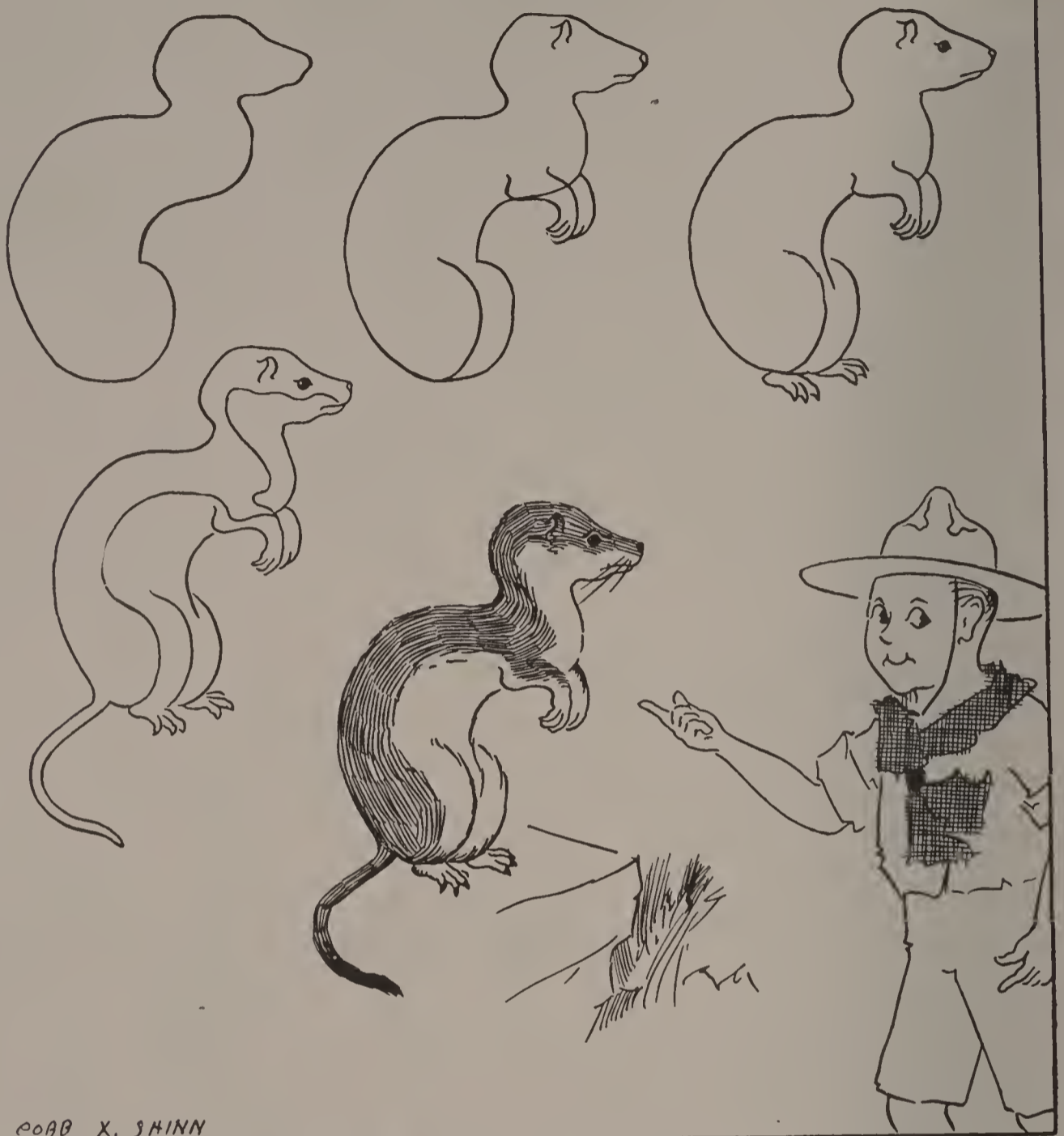

AH! How everybody hates "Sneaky" the Weasel. Farmer Jones hates him because he kills his chickens. If there is anybody who likes him it is the trapper and he wants Sneak's fur. For in the winter time he is snow white, except the tip of his tail which is black. In the winter time he is called "Ermine" but when spring comes and his coat turns reddish brown he is called just a Weasel.

WILLIE WOODCHUCK

OR GROUNDHOG AS SOME PEOPLE CALL HIM



CORB X. SHINN

DO you know Willie Woodchuck, who has very coarse hair, a heavy body, short bushy tail, powerful legs and feet armed with strong claws for digging? Farmer Jones does not like him, because he does great damage to his garden and crops. On February the second he wakes from his long winter sleep and appears at the mouth of his burrow. When he sees his shadow it is supposed to be a sign of six weeks more cold weather.

THE BISON COMMONLY CALLED BUFFALO

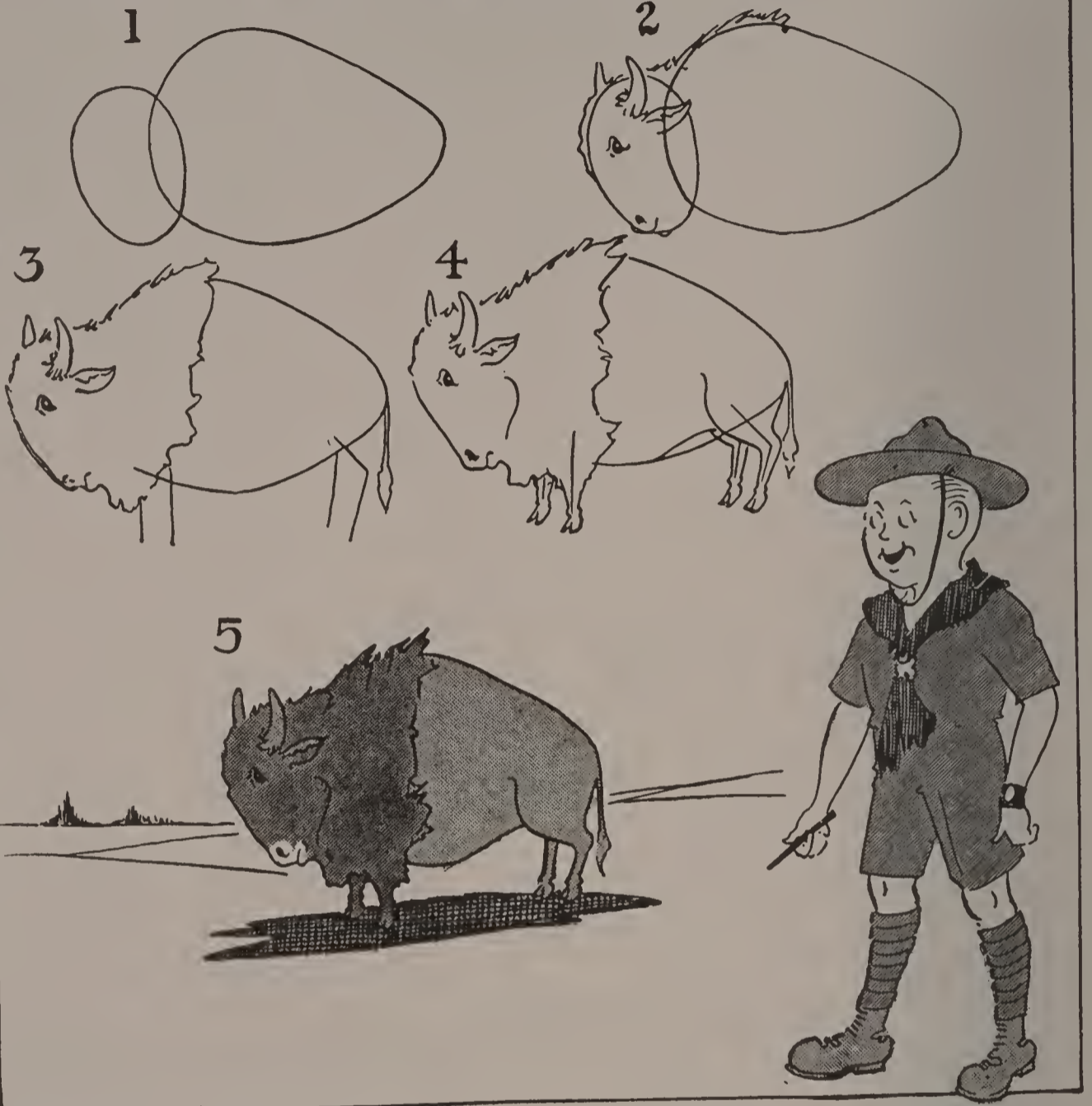

AT first you may think that this picture is very hard, but you will find it easy after you once get started. There are many funny things you will notice about a buffalo, the front half of him looks so much bigger than the rear half that it almost looks as if they did not belong together. Also the front half of him is covered with thick, curly hair and his hind quarters are covered with short hair.

BUSTER

THE LITTLE BROWN BEAR



COBB X. SHINN

THIS drawing is so very easy, the hardest part of it is to draw the two circles. When you have the circle complete it will only take you a very few minutes to complete the picture of "Buster."

BILLY BEAR WHO LIVES IN YELLOWSTONE PARK

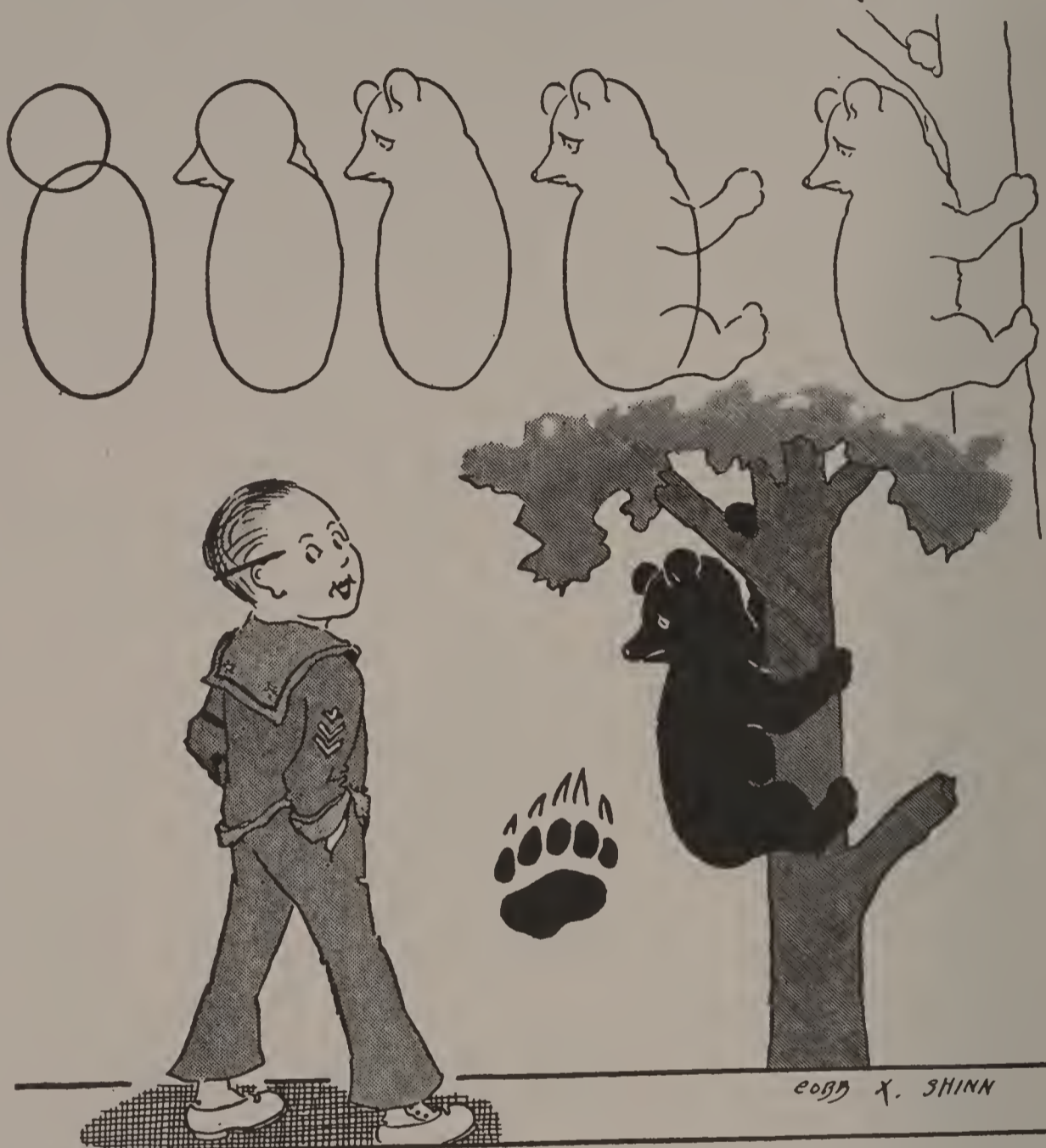

YOU can find Black Bears in a number of different places in this country, the happiest of them all are the ones that live in Yellowstone Park. It is a funny thing that most men are as afraid of Billy Bear as Billy Bear is of them. For when Billy gets even the faintest smell of man, he is gone. Also here is a drawing of the footprint of a bear. It shows you how he puts his whole foot on the ground.

HOW TO DRAW A BIG BLACK BEAR THAT WALKS ON A BALL IN A CIRCUS

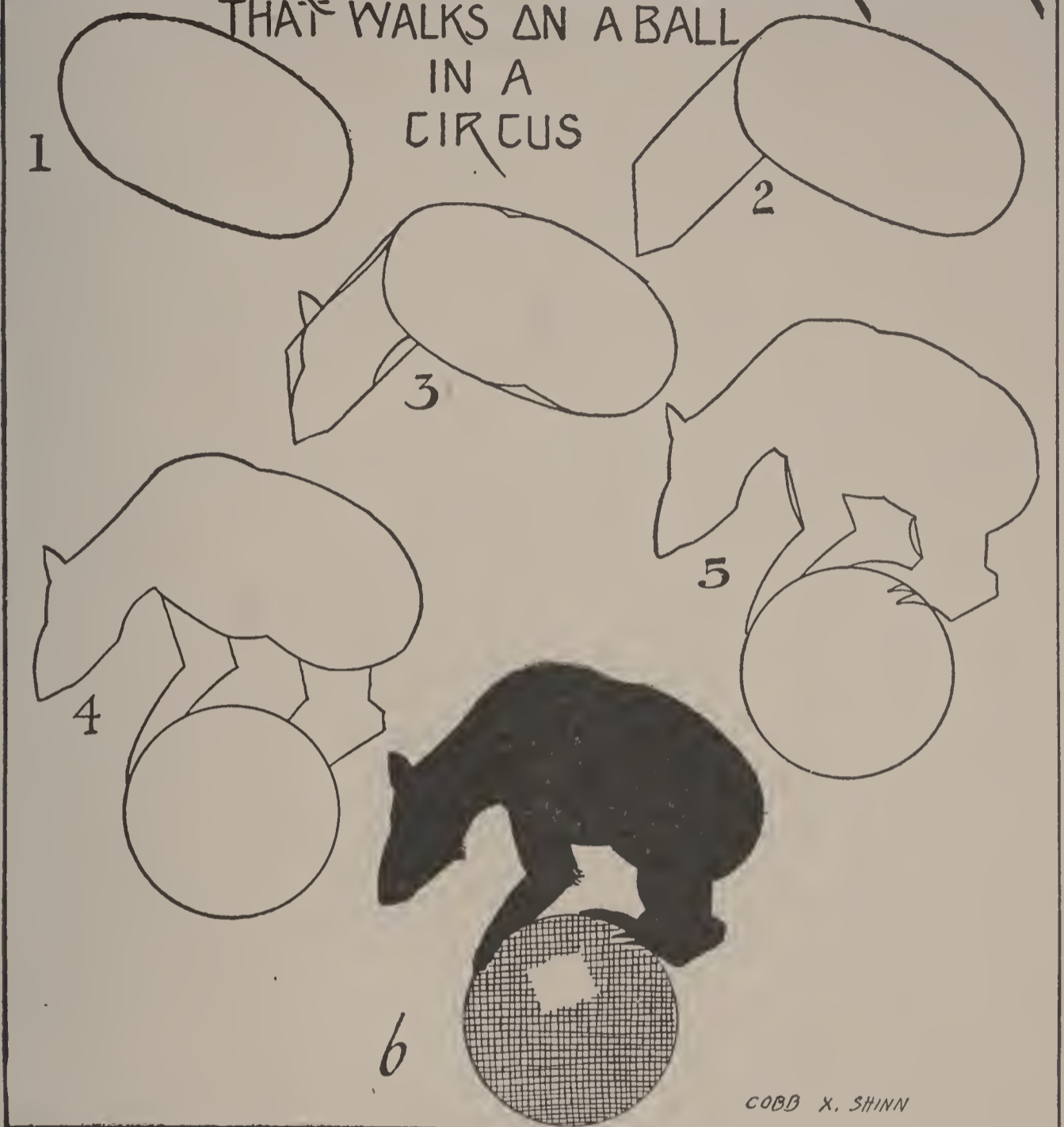

OF course every one has seen the Big Black Bear that walks on a ball in the circus. But did you ever try to draw a picture of him? If you want to try here is a very easy way to do it. Just follow the system here and you are going to find it very easy to do.

MAKE YOUR FINGERS GET BUSY
AND TRY THIS

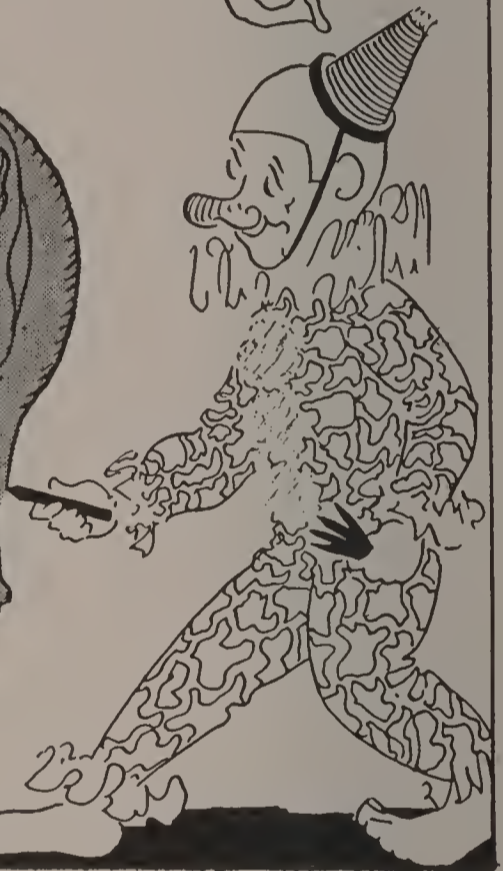
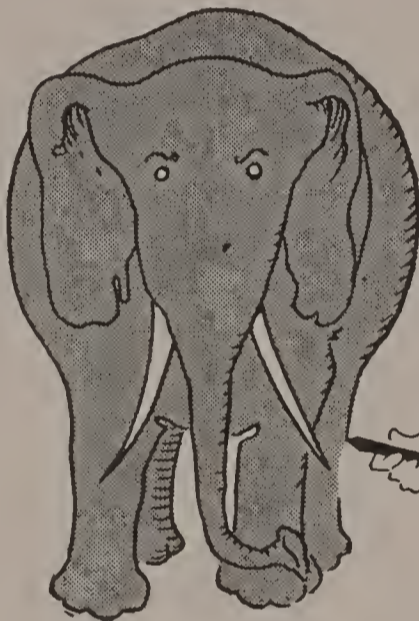
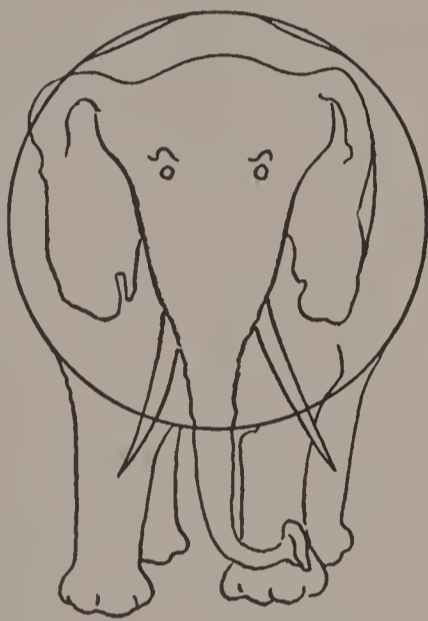

COBB X. SHINN

ONE would think that it would be a very hard matter to turn a bell into an elephant. But as the clown shows us the trick, little by little we see just how it is done. There is no reason why every little boy and girl can't do the same thing.

THIS GROTESQUE CREATURE
ONCE LIVED IN THE UNITED STATES

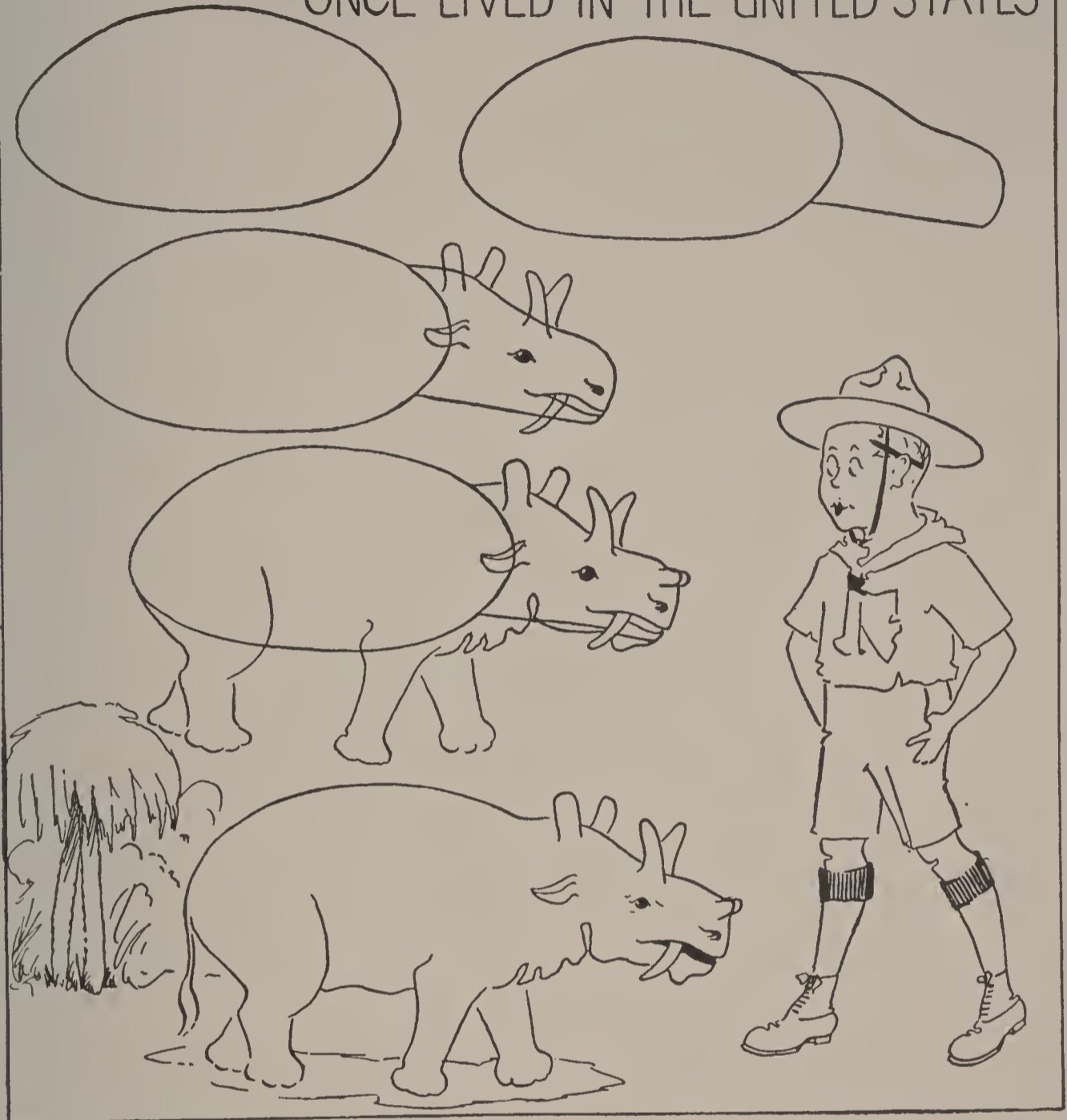

BUT it was thousands of years ago, so the wise men tell us. They do not know much about this strange creature for they just found his bones buried in the fossil beds out west. The feet were somewhat like those of an elephant, but the skull and teeth resemble nothing on this earth today.

THE **EASY** WAY FOR YOU TO DRAW A LION HEAD



COBB X. SHINN

THE Clown from the Circus shows us the quick and easy way of drawing the head of His Majesty, the Lion. It is so very easy that every boy and girl should be able to make a good picture of a Lion.

A

CAUSIN ΔF YOUR KITTY CAT

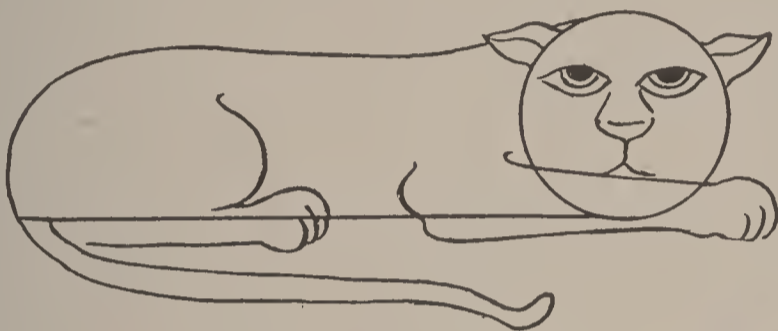
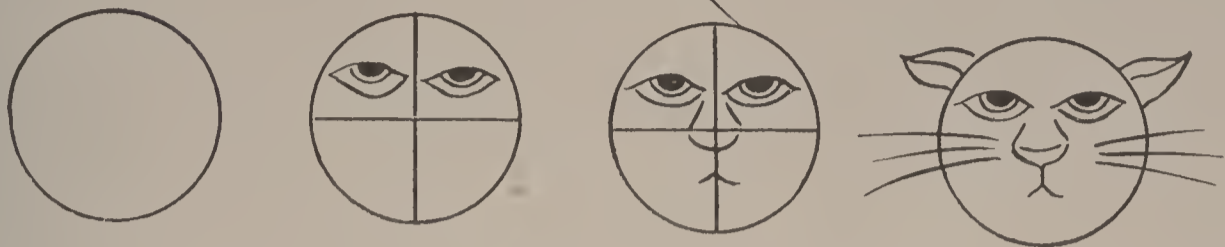

COBB X. SHINN

OUR Little Friend from India is glad to show you the easy way to draw a picture of an animal that lives in his country, "The Tiger." In Africa the Lion is the "King of Beasts" but in India his place is taken by the Tiger.

MR. RACCOON

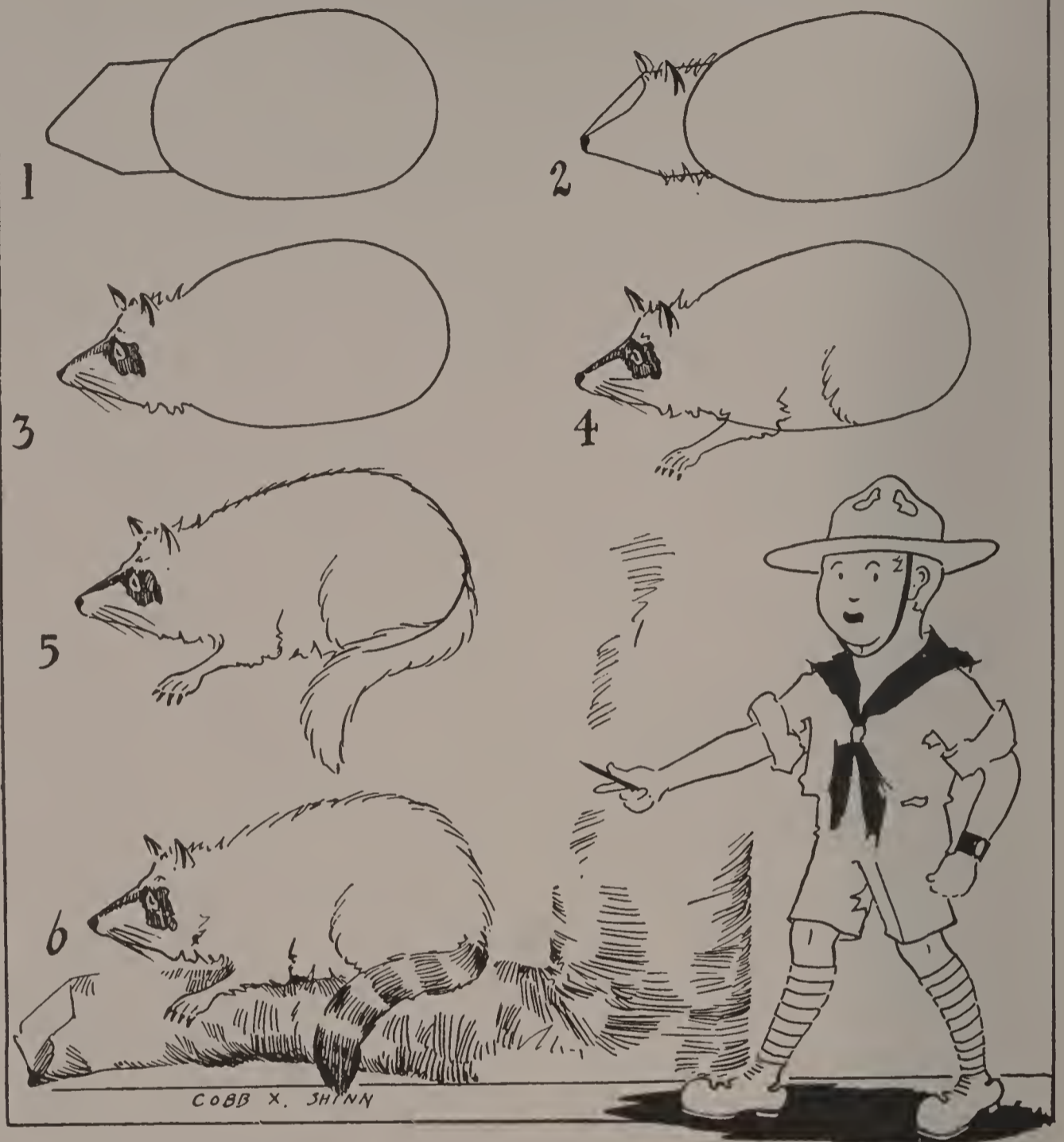

MOST of you know Mr. Raccoon. But did you know that he had a funny habit of always taking his food to water so he could wash it before he eats? Also he will sneak up to the henhouse and steal the eggs. He is not a bad fisherman when it comes to catching fish or he is very happy when he finds a field of young corn, he loves roasting ears. There is not much need of Mr. Raccoon ever going hungry.

THE JUMPING MOUSE WHO LIVES IN OLD WEEDY FIELDS



THE Little Jumping Mouse is one of the handsomest members of the mouse family with his coat of a dull yellowish color, darker on the back than on the sides, and white underneath. He is one of the best jumpers of his size among the little animals. You will find his home most of the time in old weed patches for he is very fond of small seeds.

A SHIP TO SAIL IN THE GOLDFISH'S BOWL

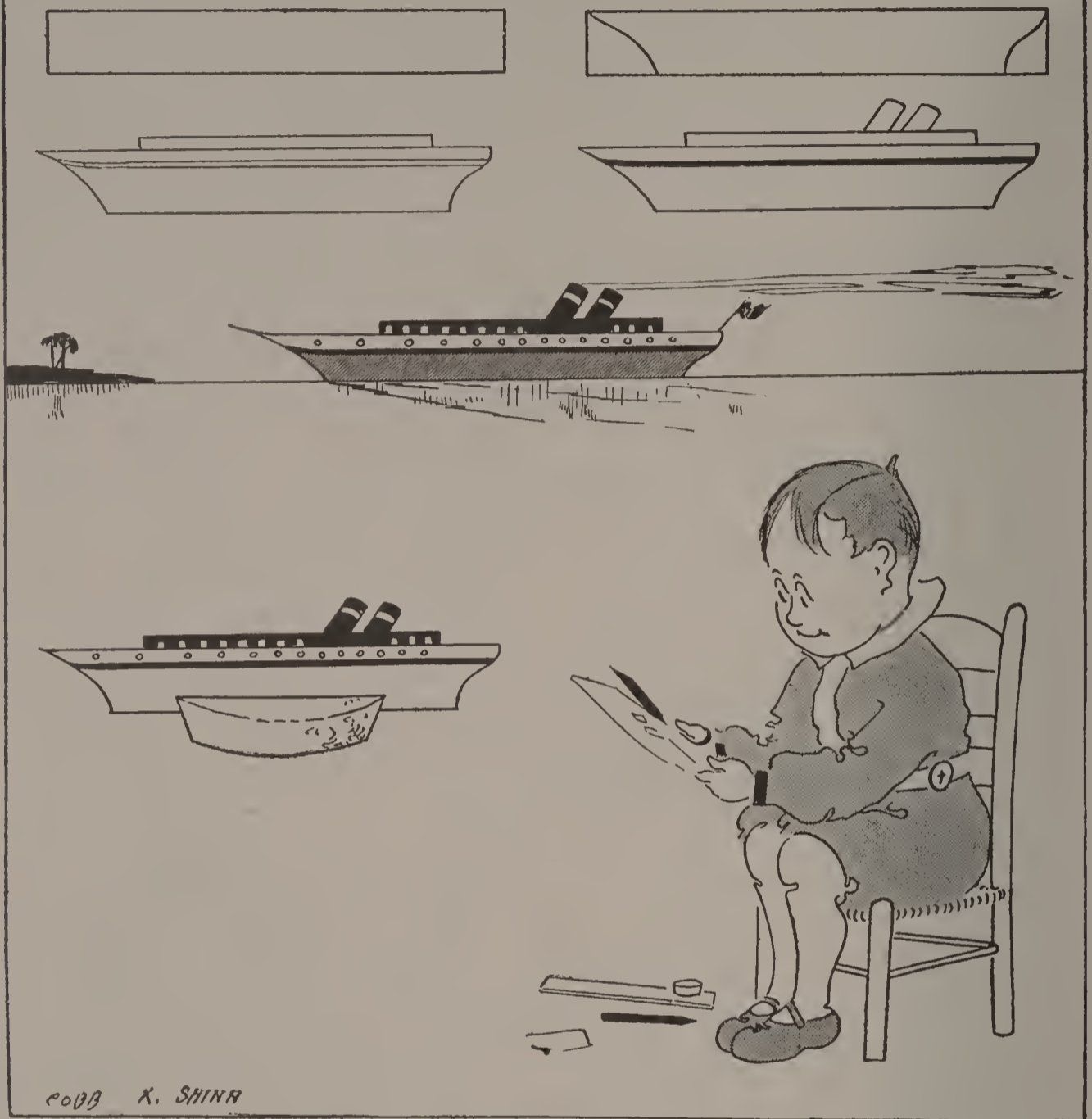

POBB K. SHINN

FIRST you see just how you can draw a ship sailing on the deep blue sea. If you like make your little fingers get busy and cut out your drawing of the ship. Then slit a cork crosswise and slip the drawing into it. There you have a ship to sail on the goldfish bowl.

HUMPTY DUMPTY SAT ON A WALL

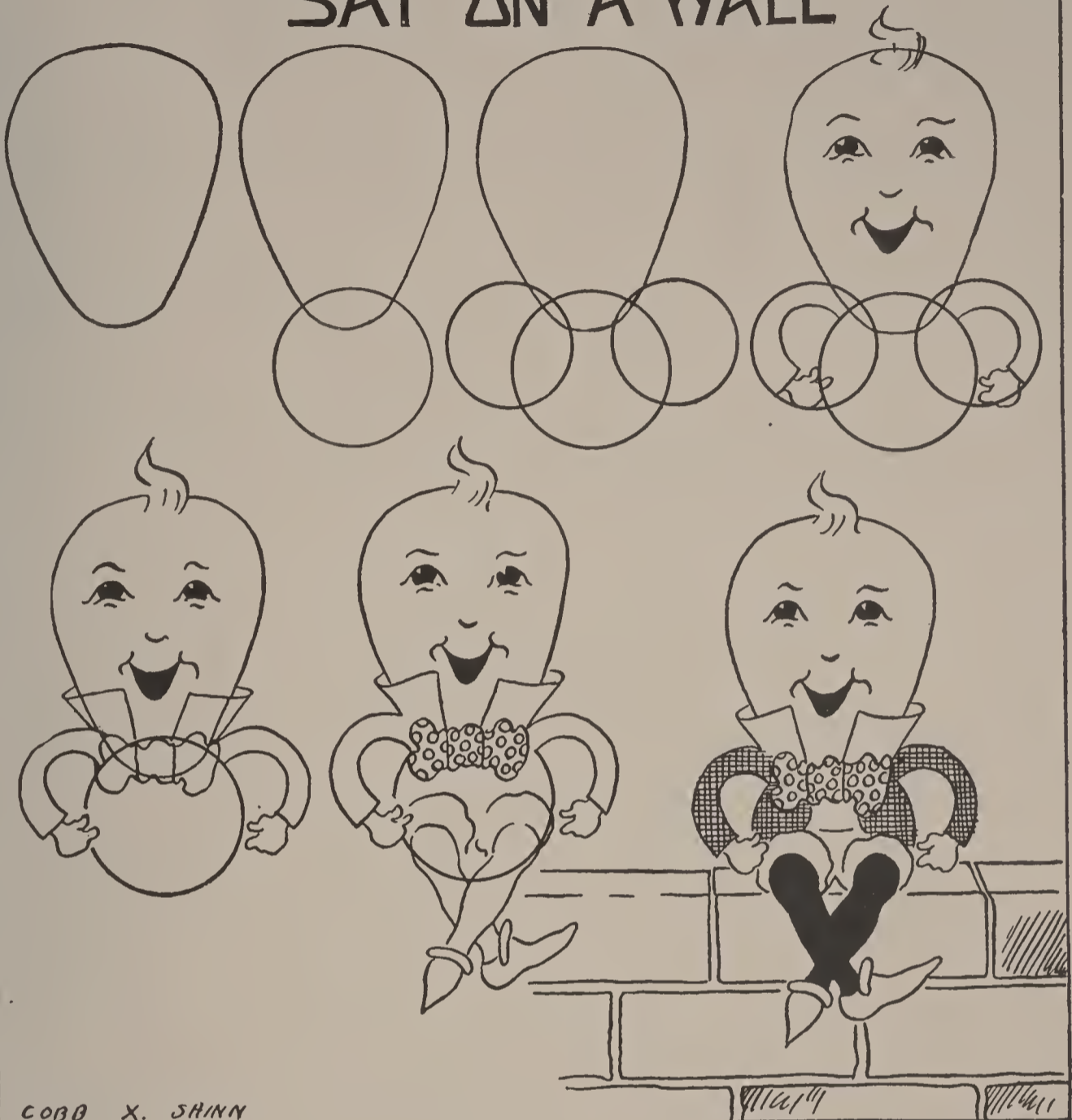

“**H**UMPTY DUMPTY” was an egg as every boy and girl knows, so first you must start your drawing with an egg. Then add the three circles and little by little change them into his body. Now all that it takes to complete your picture are the legs and the wall.

THE EASY WAY TO DRAW A THING THAT IS HARD TO DRAW

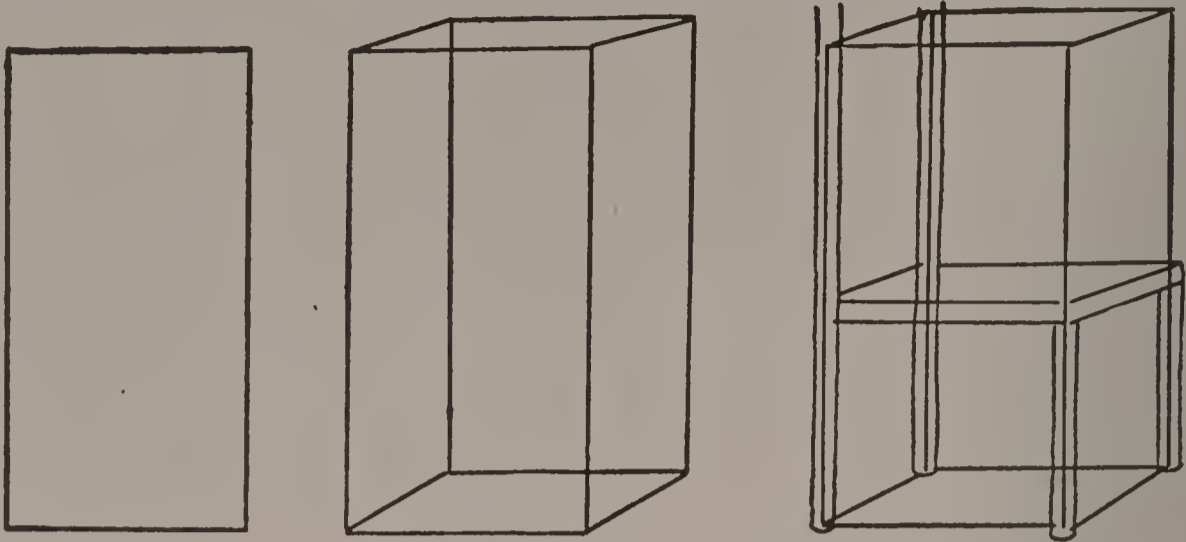

COBB X. SHINN

ALMOST any artist will tell you that a chair is a very hard thing to draw. But if you will just follow this system, you will find that a chair is not so hard to draw. Of course you make a lot of lines which you cannot use in your finished drawing, but these lines help you to get the chair square and make it look like a real chair.



CUTE LITTLE HOUSES FOR YOU TO DRAW



THEY are very easy to draw, if you start with letters and then add the doors and windows. After you have tried your hand at making these, try and see if you can make some of the others into little houses.

YOU CAN FIND MANY INTERESTING THINGS IN THE KITCHEN

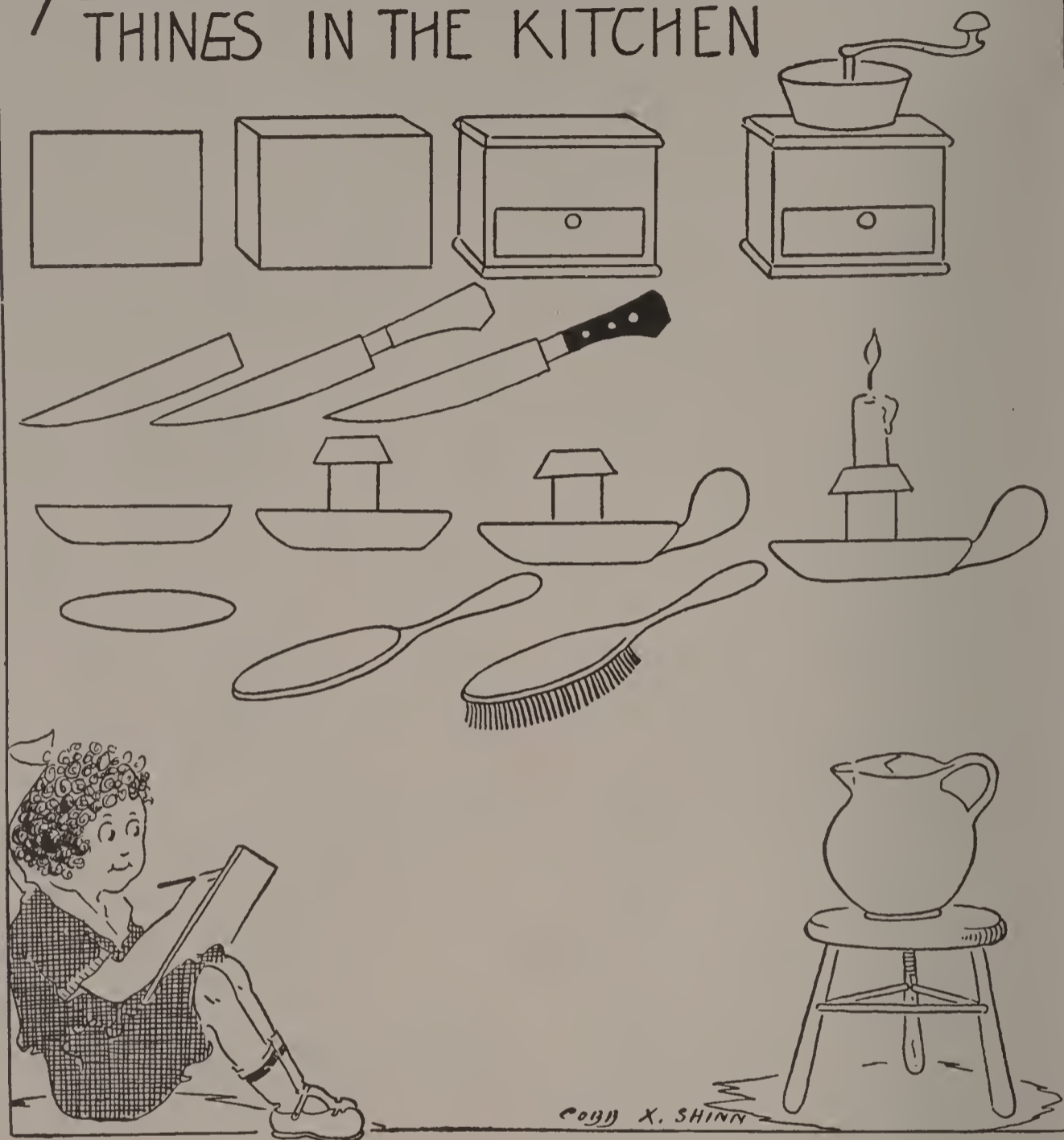

“JUST what shall I draw?” How many times have you asked this question? If you would just stop and look around the room a minute you can find many interesting things. Just to get you started here are a few things from the kitchen for you to practice on. When you have made these, try and see how many different things that you can find in the living room to draw.

TWO DRAWINGS EASY FOR YOUR LITTLE HANDS TO MAKE

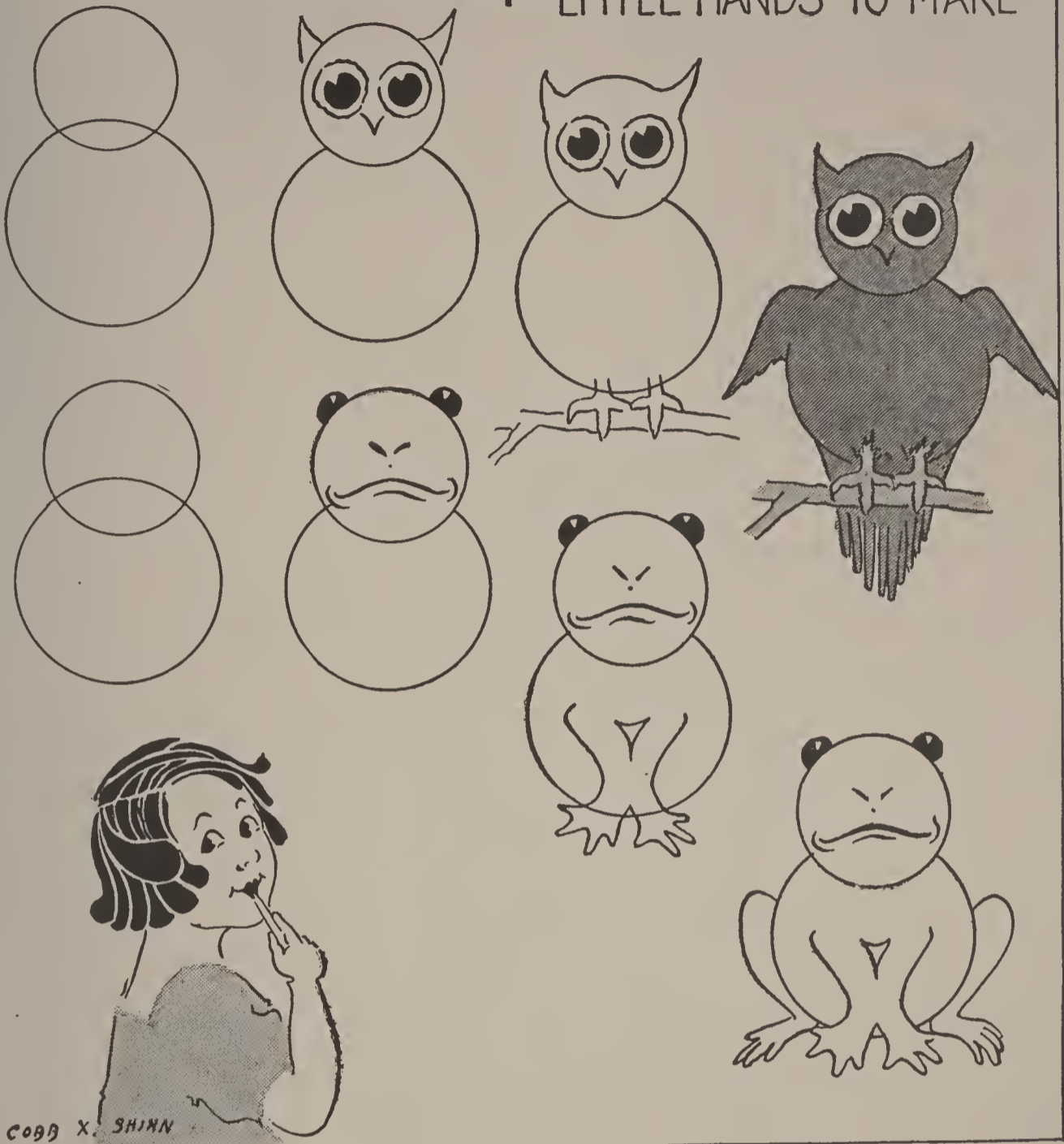

THESE two pictures are very easy to draw if you will make two circles. One the size of a twenty-five cent piece and the other about the size of a nickel.

"SKATING PARTY" in Circle Town

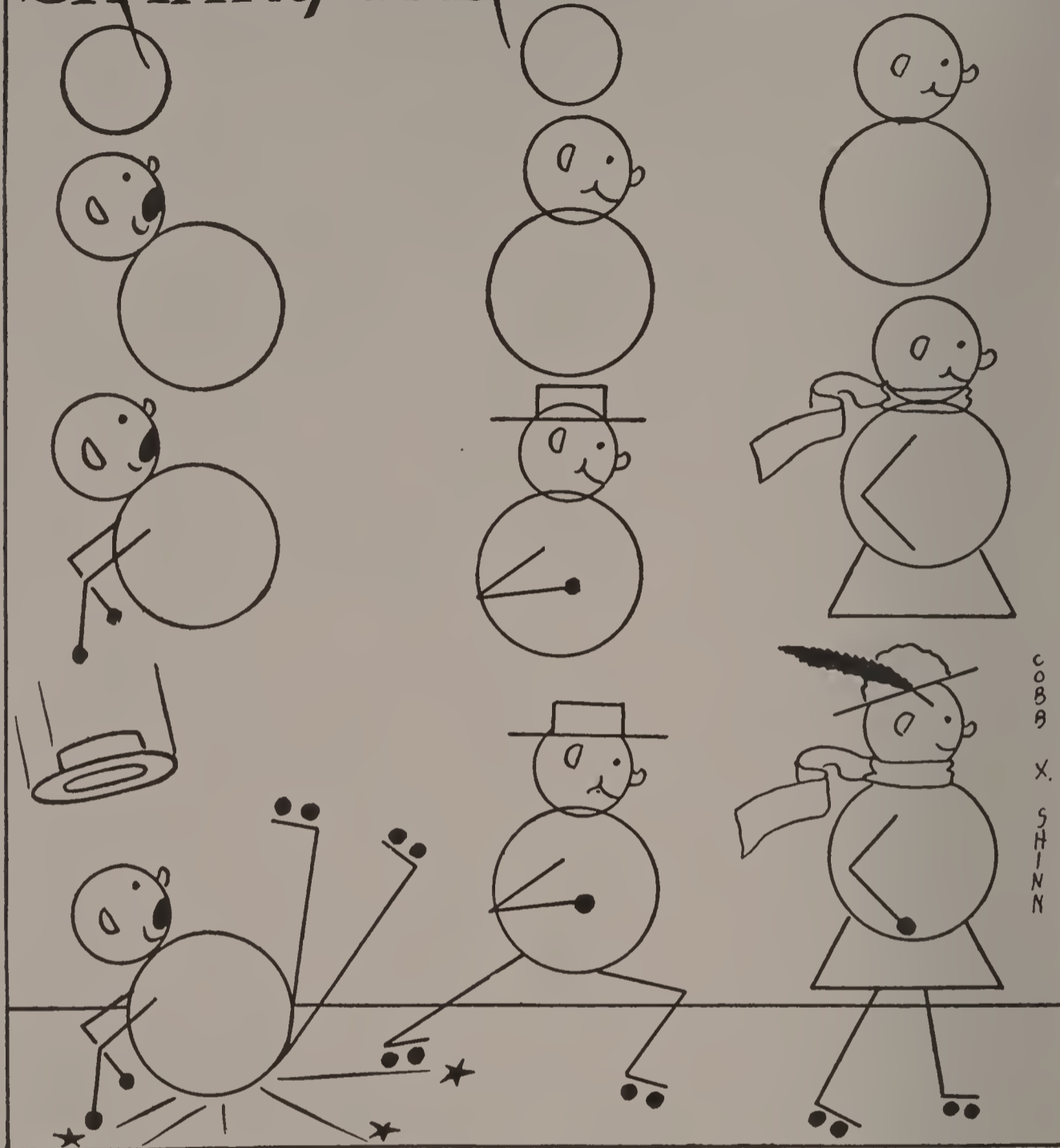

SEE how easy it is to draw the children of Circle Town. Now that you know this little secret it should be easy for you to draw them playing a game of Leap-frog. Try and see how many different games you can make them play or things that you can make them do.

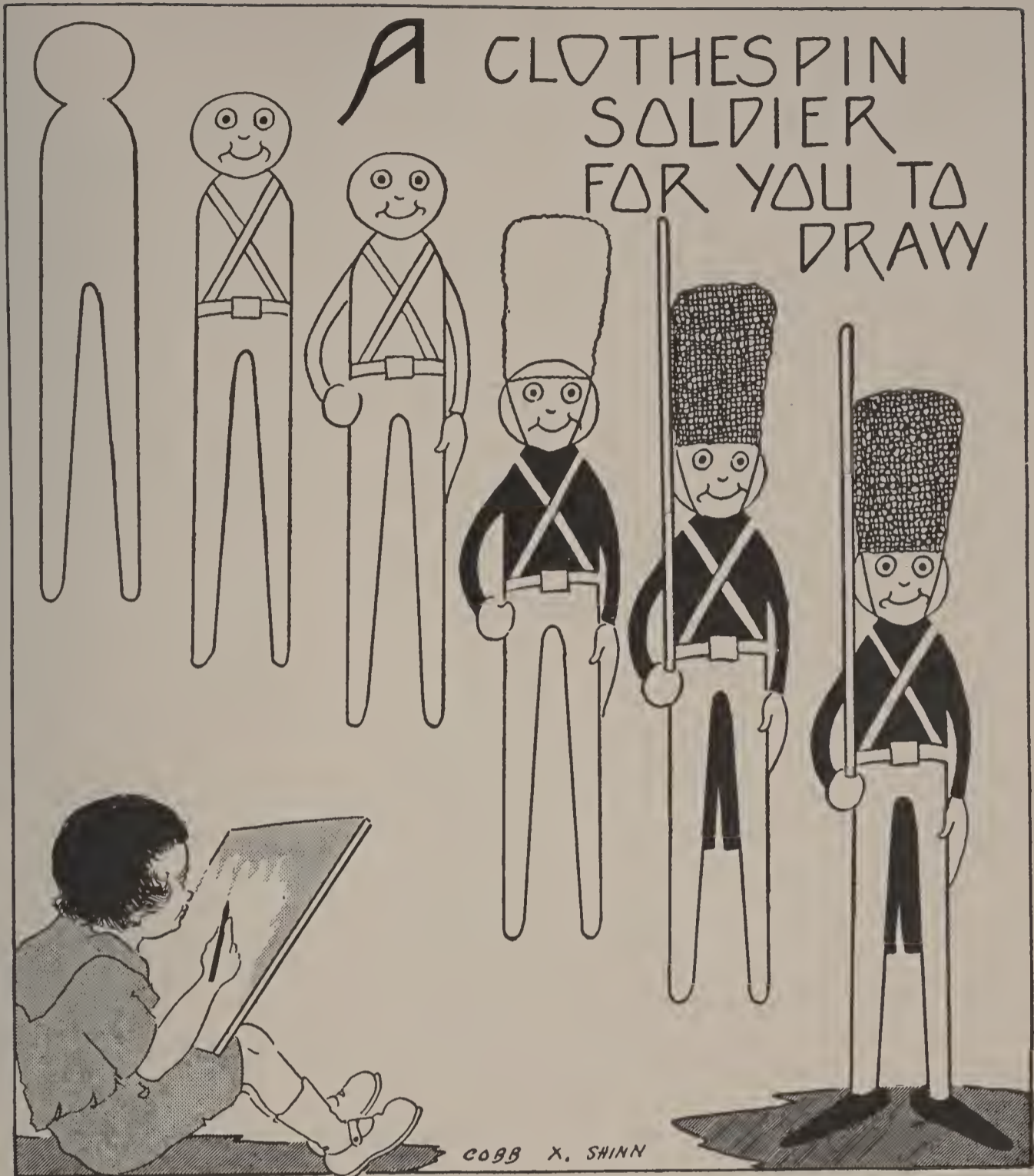

A CLOTHESPIN is about the easiest thing drawn that you can think of, and when you have the clothespin made, you have a great start on drawing a soldier. As you see it does not take many more lines to complete the toy soldier.

STUNTS THAT YOU CAN DO WITH AN ACORN



COBB X. SHINN

YOU would not like to think that you were not able to draw a picture of an acorn, would you? If you can, why you can make almost any number of funny faces out of them. Little Miss Mary is just showing you three different kinds that she can make. Are you going to make your little fingers get busy and see if you can make the same ones and many other different kinds?

A BOTTLE OF INK TURNED INTO A PICKANINNY

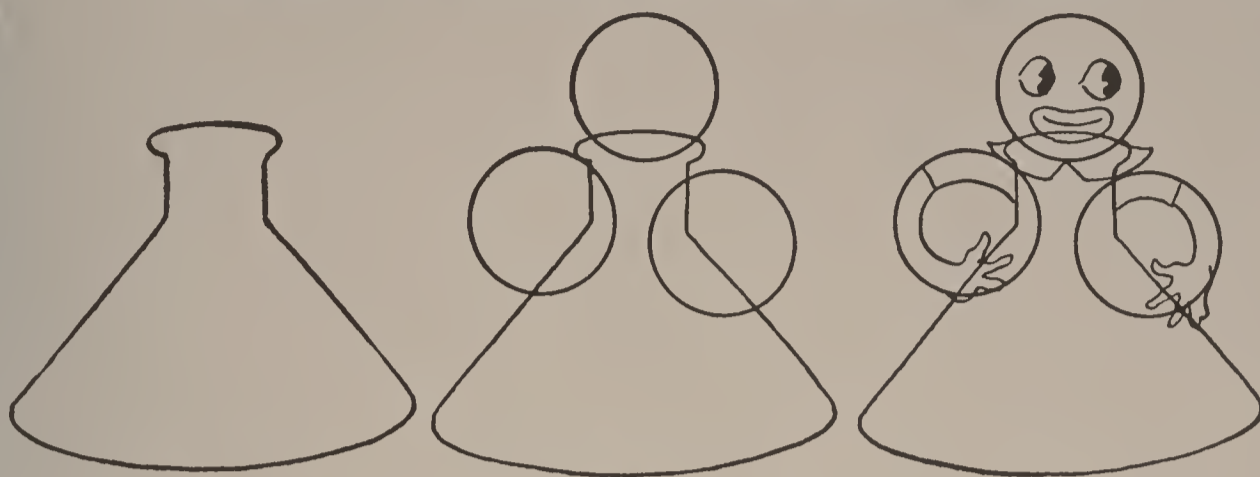

COBB X. SHINN

THE bottle of ink is very easy to draw and a nickel will do to make the three circles. When you have this much made you have a very good start and the rest is very easy to do. You do not have to make the dress just the same as this one. Can't you think up some kind of different dress for the Pickaninny?

THE EASY WAY TO DRAW ANY OBJECT

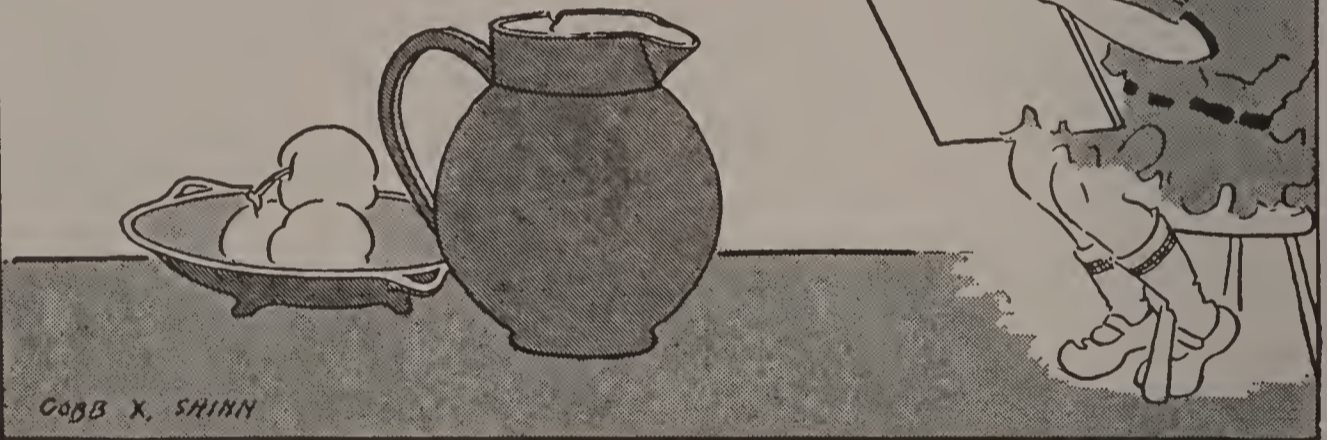
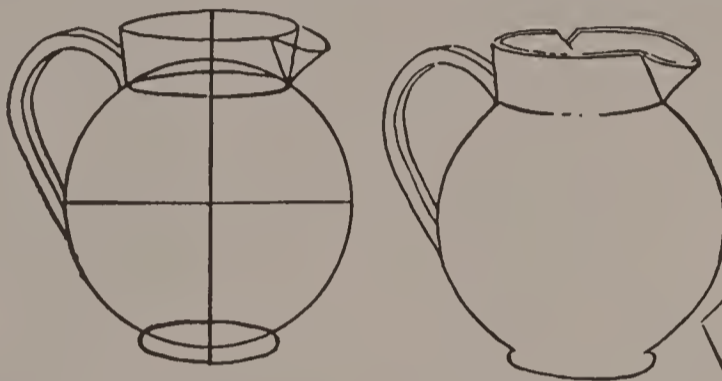
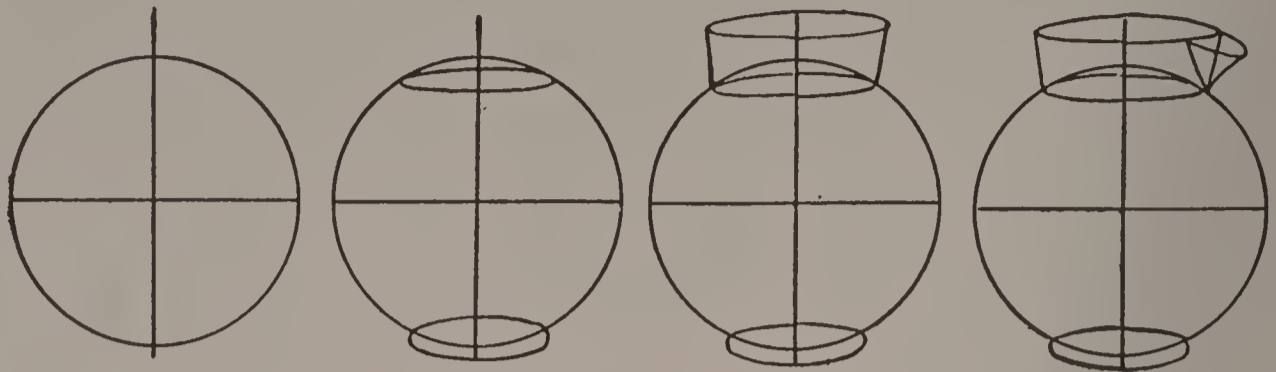

IT is very interesting to see just how many lines the artist has used in drawing the pitcher and so few are used in the complete drawing. It may look like a very hard way to draw, but nevertheless it is the quick way if you want to draw correctly. First you try your way of drawing a pitcher and then try this way. Now compare the two drawings and see the difference.

SEE WHAT YOU CAN DRAW

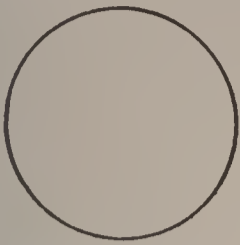

WITH
A CIRCLE AND A FEW STRAIGHT LINES

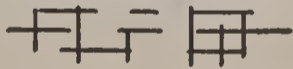

S46

HERE are just two things, "Reddy Fox" and "A Sail Boat" that you can draw with a few straight lines and a circle. Try making these and see how easy they are to draw. Then you can see how many other things that you can draw with just straight lines and a circle.

THE EASY WAY TO MAKE A FIVE-POINTED STAR

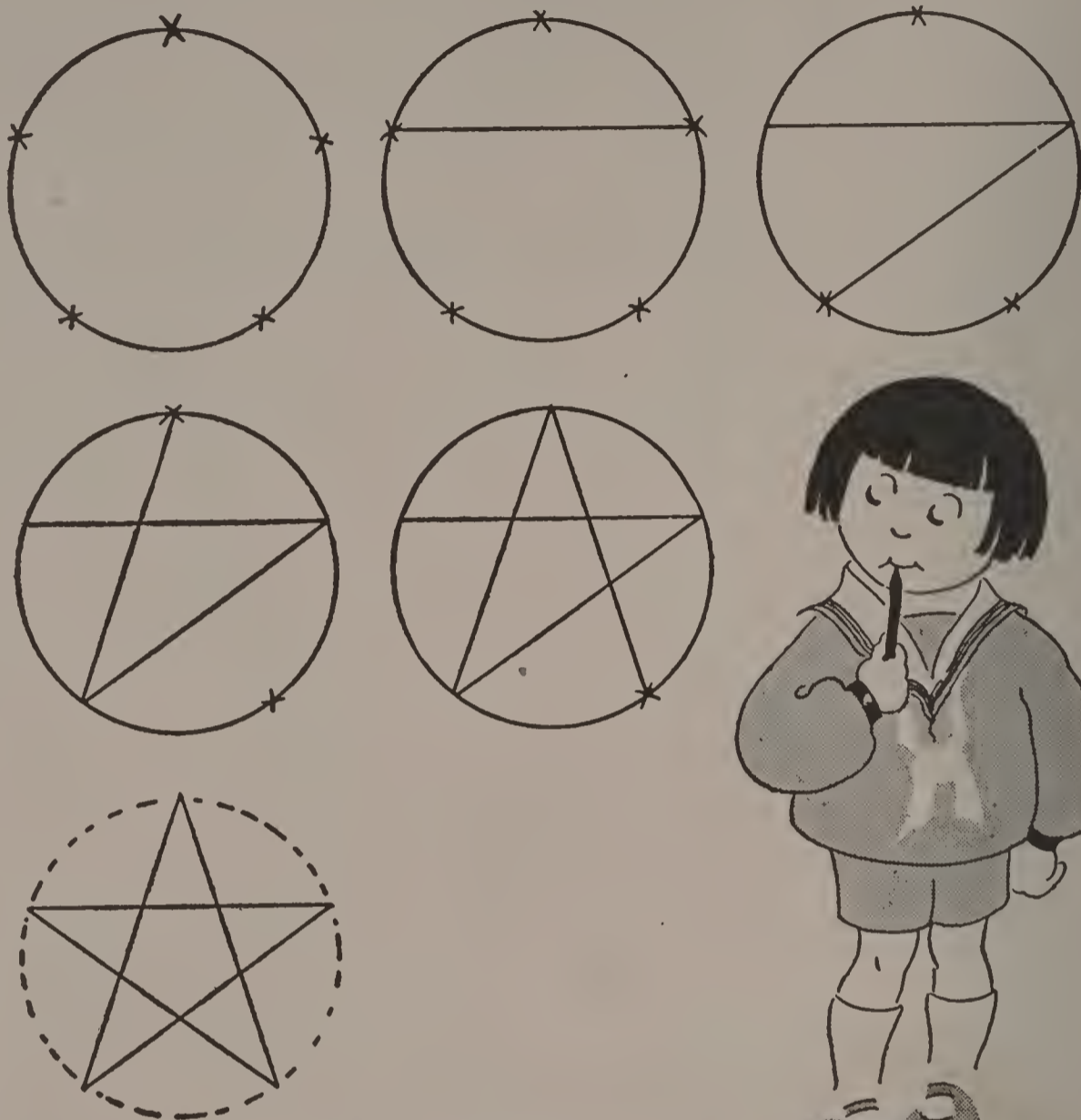

COBB X SHINN

MAKING a five-pointed star is very easy to do if you will just make a circle first, then mark off five points at equal distances on the circle. Now draw a line from left to right and the next line make just the same as Tommie has in the chart. If you will just practice making these stars, the first thing you know you will not have to mark the points on the circle.

EASY *and* CLEVER STUNTS THAT YOU CAN DO



YOU START
WITH A LEMON



AND ADD A
FEW FEATURES



A COFFEE POT CAN BE MADE INTO A FRENCH COOK



COBB X. SHINN

THERE are many other things besides these that can be changed into heads, but first you must learn how to make these. You don't have to know anything about drawing to be able to draw a lemon or a coffee pot, and then little by little you add to these things, and the first thing that you know you have completed a head.

DID YOU EVER NOTICE ?

A HUMAN HEAD IS ALMOST EGG-SHAPE



THE NOSE AND EAR ARE ON A LINE

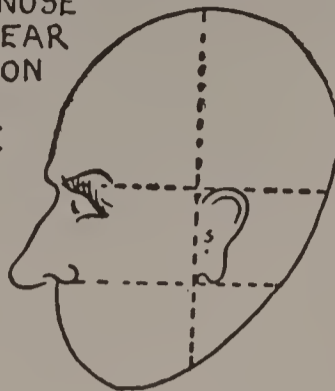

THE NECK STARTS ON A LINE WITH THE EAR AND NOSE

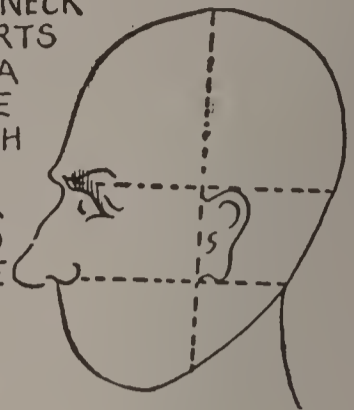

THE FORE HEAD IS ABOUT ONE FOURTH THE LENGTH OF THE HEAD

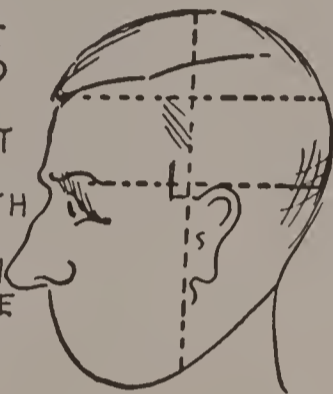

THE LOWER PART OF THE FACE IS DIVIDED INTO THREE PARTS

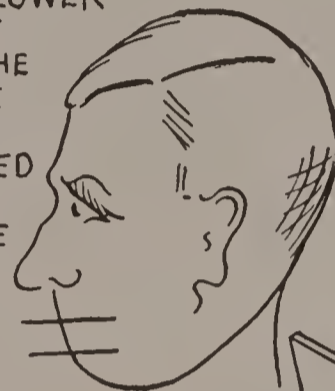

UPPER LIP, LOWER LIP AND CHIN



COBB X SHINN



THERE are more boys and girls who want to draw the human head than any other object. And it is the most interesting thing to draw even if it is the hardest to draw. Yet there are a few very simple rules to go by that will help to make it easy. Like, first making an oval and then marking just where each feature is to go.

U

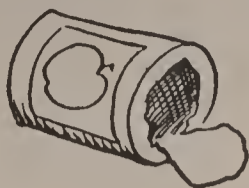

DRAW IT! TRY IT!



TEA CUP AND SAUCER



ADD A FEW FEATURES



AND THEN
TURN IT
UP
SIDE
DOWN



COBB X. SHINN

IT'S jolly fun to draw a tea cup and saucer, then see if you can make a head of a person out of it. Then turn it upside down and see if you can make it look like another head by just adding a few more lines.

A

TWISTER FOR YOUR PENCIL



A FEW LINES WILL MAKE A FUNNY LOOKING RABBIT



AND



A FEW MORE LINES

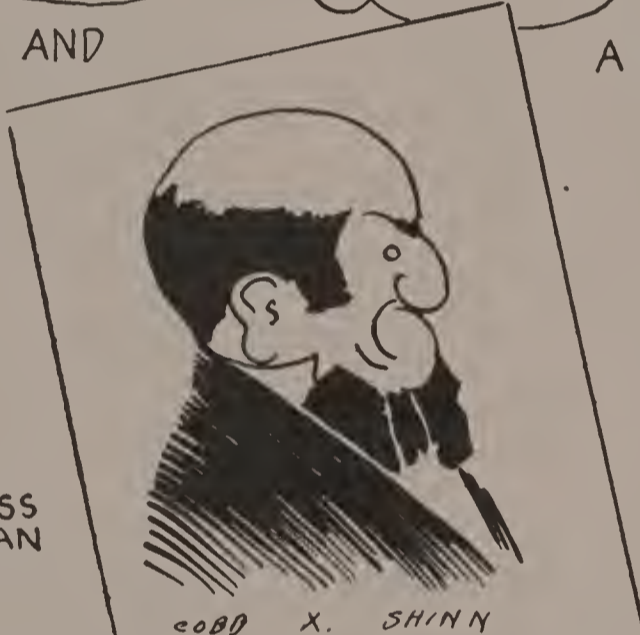

MAKES
A
TOOTHLESS
OLD MAN

COBB X. SHINN



YOU can make a lot of these pictures of rabbits and when you have a party at your house, give one to each one of the guests. Then to the one who does the best job of twisting the rabbit into a toothless old man, you can give a prize.

MAKE OUTLINE PICTURES OF YOUR FRIENDS



A SILHOUETTE PORTRAIT

YEARs ago before the camera was invented, this way of making pictures was very common. Now any clever boy or girl can make pictures of his or her friends. All that you need to do is to fasten a piece of paper on a flat wall; put the sitter near it. Place a good light at the side so that it throws a shadow of your friend on the paper. The sitter must sit perfectly still.

FUNNY FACES

THAT YOU CAN MAKE
OUT OF THE ABC'S

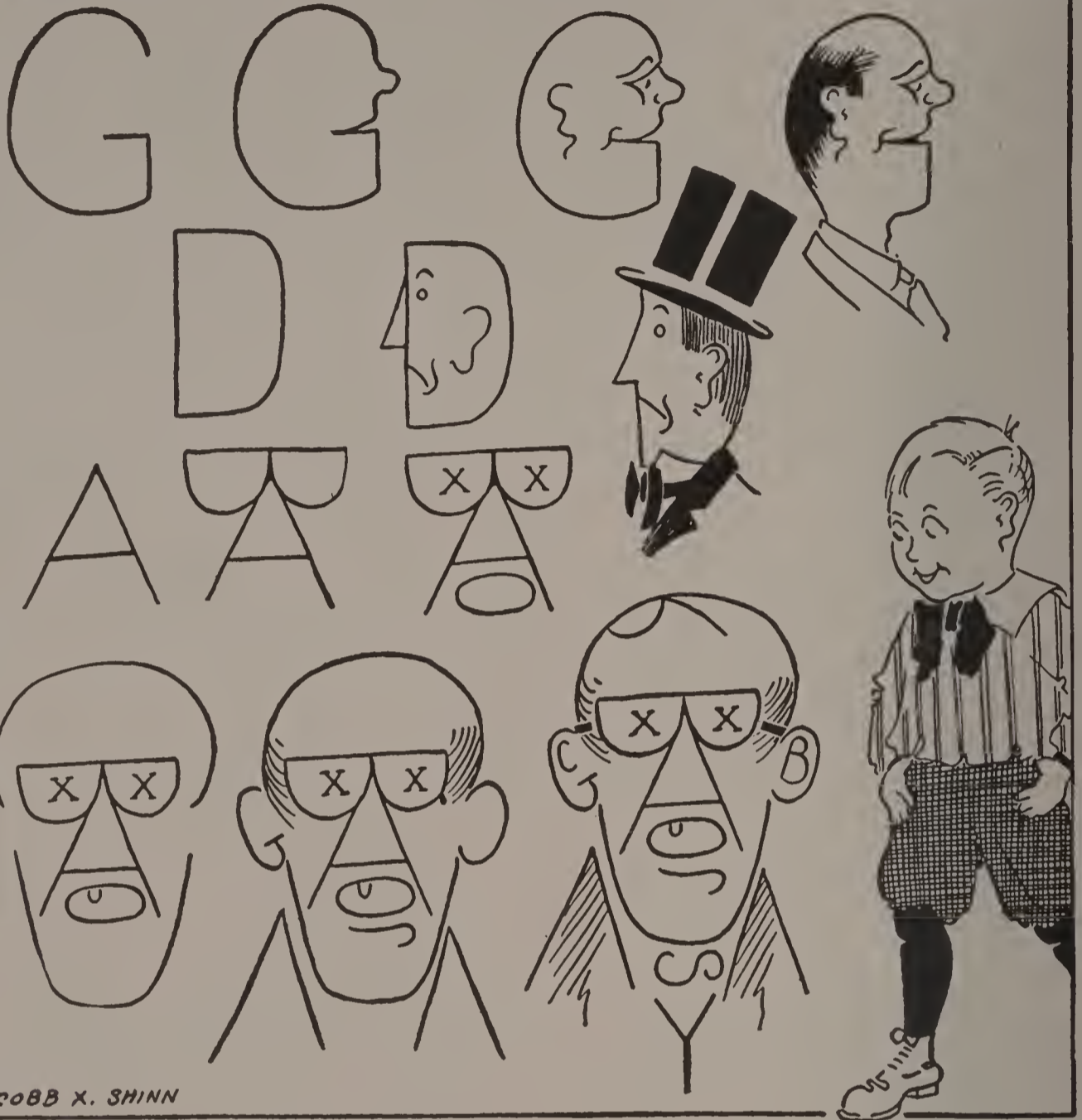

COBB X. SHINN

THERE are funny faces you can make out of just one letter, like Mr. Gee Whizz or there is Old Man Alphabet which it takes many letters to make. Can you tell how many different letters that it took to make Old Man Alphabet?

CLEVER PICTURES THAT YOU CAN MAKE WITH A FEW STRAIGHT LINES

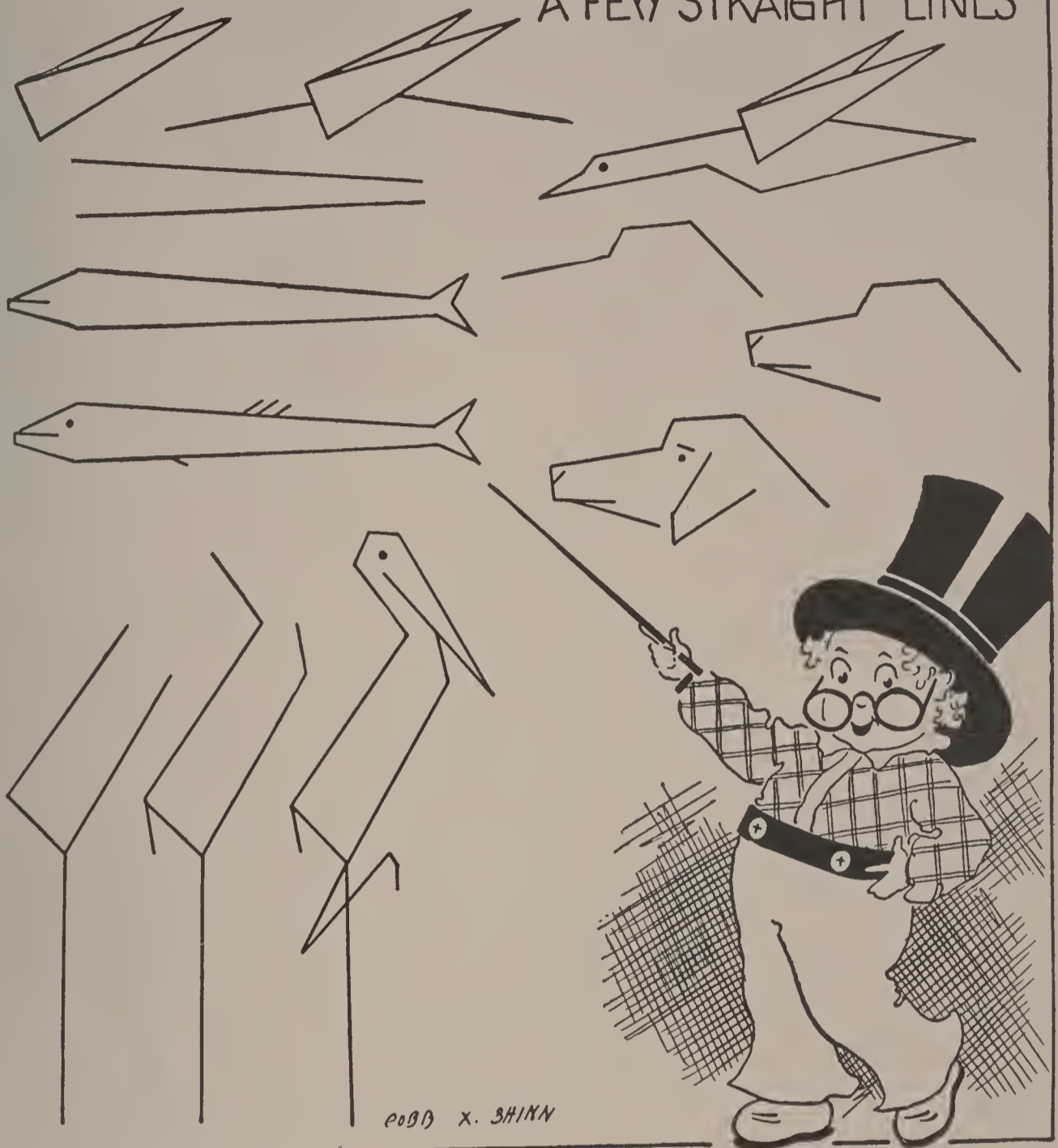

POBB X. SHINN

THE Little Drawing Teacher shows you four different animals that you draw with just straight lines. If you think that you cannot make your lines straight, use your ruler. Then you will be sure to make your drawings as good as these. After you have finished see what else you can draw with just a few straight lines.

UNCLE SAM

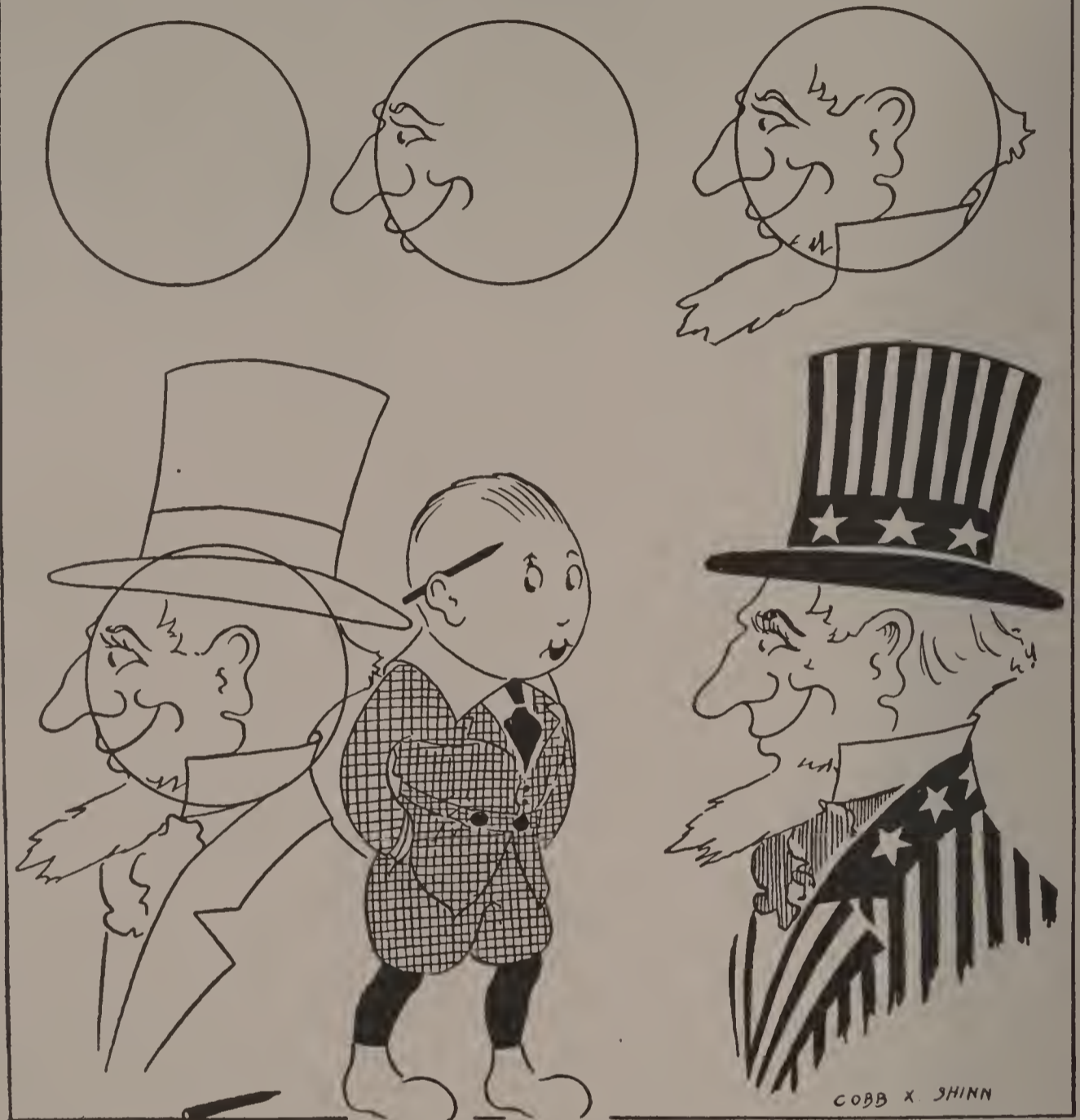

HARRY says, "That every boy and girl should know how to draw a picture of their Uncle Sam. First you draw a circle, now you put a nose on it, add the mouth and eye. Then you are ready to put in the ear and don't forget the whiskers for it would never look like Uncle Sam without whiskers. Now you can put his hat and coat on. By putting stars and stripes on the hat and coat you will have completed Uncle Sam."

LETTERS *and* FIGURES

A B C D E F G H I J K L M
N O P Q R S T U V W X Y
1 2 3 4 5 6 7 8 9 0



POBB X. SHINY

AN easy way to “print” signs and posters is on cross-section paper. In this way you are sure to get the letters correctly shaped. Just take a plain piece of paper and mark off the cross-sections with a soft lead pencil, then you can erase these lines when you have poster completed. In this same manner you can make very pretty greeting cards to send your friends on their birthdays. Use your water colors to paint the flowers and the capital letters.

LIBRARY OF CONGRESS



0 033 261 053 3