

510

Charles I. Jeffery
Kenosha, Wis

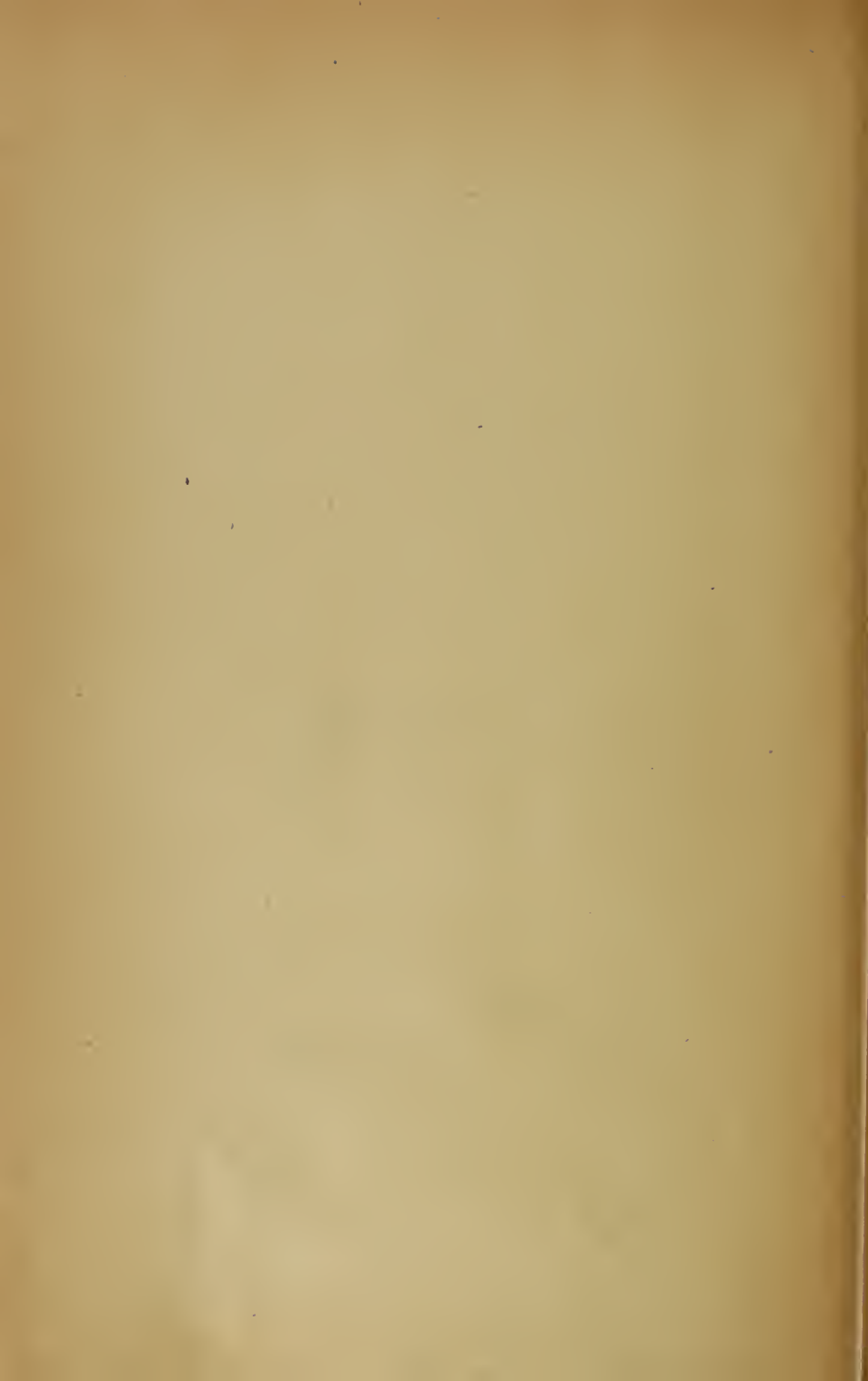



GANOT'S PHYSICS



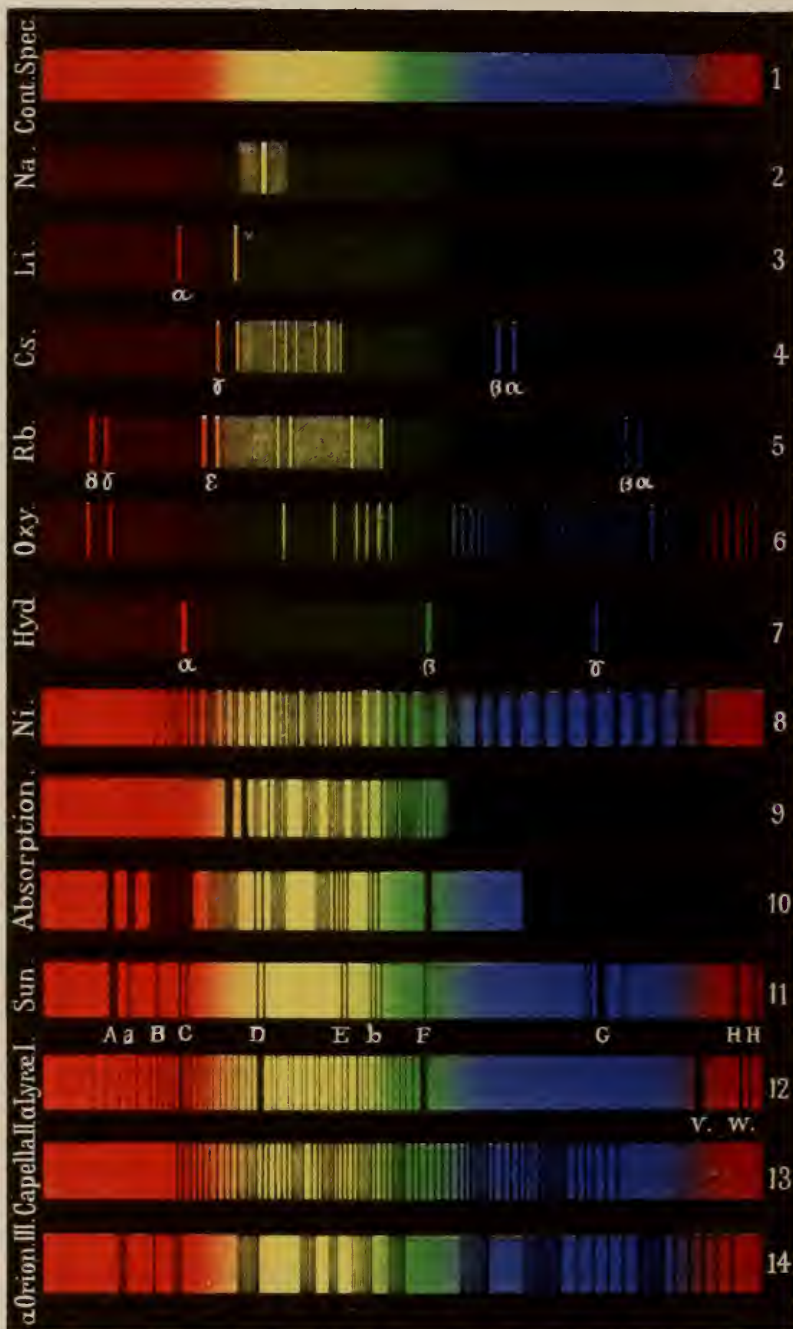

The absorption Spectra 9 & 10, are those respectively of Nitrous Acid and Chlorophyl.

ELEMENTARY TREATISE
ON

PHYSICS

EXPERIMENTAL AND APPLIED.

BY

WILLIAM WOODS AND THOMAS

W. WOODS

AND THOMAS

W. WOODS

AND THOMAS

WILLIAM WOODS AND THOMAS

OF THE

NEW YORK

TABLE OF CONTENTS

[The following table is extremely faded and illegible. It appears to be a table of contents with multiple rows and columns, possibly listing chapters or sections of a book. The text is too blurry to transcribe accurately.]

ELEMENTARY TREATISE

ON

PHYSICS

EXPERIMENTAL AND APPLIED

FOR THE USE OF COLLEGES AND SCHOOLS

TRANSLATED FROM

GANOT'S ÉLÉMENTS DE PHYSIQUE

(with the Author's sanction)

BY

E. ATKINSON, PH.D., F.C.S.

LATE PROFESSOR OF EXPERIMENTAL SCIENCE IN THE STAFF COLLEGE

SEVENTEENTH EDITION

EDITED BY

A. W. REINOLD, M.A., F.R.S.

PROFESSOR OF PHYSICS IN THE ROYAL NAVAL COLLEGE, GREENWICH

ILLUSTRATED by 9 COLOURED PLATES and MAPS and 1048 WOODCUTS

WILLIAM WOOD AND COMPANY

51 FIFTH AVENUE

NEW YORK

1905

ADVERTISEMENT

TO

THE SEVENTEENTH EDITION

IN the present Edition, while the general character and scope of the work, which marked the Sixteenth Edition, have been maintained, considerable additions and modifications in detail have been made, and the whole has been carefully revised. The chapter on the Steam-Engine has been rewritten and brought up to date by Eng.-Lieut. Leslie Robins, R.N., to whom my thanks are due, and I am indebted to Mr. Arthur Haddon, of the Royal Naval College, for a similar service in connection with the articles on Photography. Numerous additional examples and problems, especially in Magnetism and Electricity, will be found at the end of the volume.

It may be as well to point out once more that the book is intended to be a general Elementary Treatise on Physics, and that, while it accordingly aims at giving an account of the most important facts and general laws of all branches of Physics, an attempt to treat completely and exhaustively of any one branch would be both inconsistent with the general plan of the book and impossible within the available space.

A. W. REINOLD.

ROYAL NAVAL COLLEGE, GREENWICH :
August 1905.

LIST OF TABLES

	PAGE		PAGE
ABSORBING powers	421, 436	HARDNESS, scale of	87
Absorption of gases	173, 178	LATENT heat, of evaporation	362
_____ heat by gases	437	_____ fusion	463
_____ liquids	433	MAGNETIC declination	734
_____ vapours	434, 438	_____ inclination	734, 740
Atmosphere, composition of	148	_____ permeability	930
BAROMETRIC variations	159	PRESSURE of aqueous vapour	348
Boiling points	353, 377, 378	_____ vapours of liquids	349
CAPILLARY constants	127	RADIATING powers	420, 421
Coefficients of thermal conductivity	405	Radiation, luminous and obscure	430
Combustion, heat of	499	Reflecting powers	420
Conducting powers of solids for heat	404	Refraction, angle of double	671
_____ liquids for heat	408	Refractive indices	566, 1054
Conductors of electricity	752	_____ of media of eye	642
Critical temperatures	377	_____ gases	1055
DENSITIES of gases	327	SOLUTION	332
_____ vapours	391	Sound, transmission of, in tubes	216
Density of water	317	Specific gravity of liquids	114
Diamagnetism	1043	_____ solids	112
Diathermanous power	432	_____ heat of solids and liquids	456
Dielectric strength	803	_____ gases	460, 461
Diffusion of solutions	132	_____ inductive capacities	803
Dulong and Petit's law	457	Striking distance	824
ELASTICITY. Breaking weight	86	Surface tension	127
_____ Volume	79	TELESCOPES, notable	621
_____ Young's modulus	80	Temperatures, various remarkable	301
Electric resistance of metals and alloys	872	_____ at different latitudes	1112
_____ liquids	873	_____ of thermal springs	1114
Electricity, positive and negative	757	_____ of heated metals	324
Electrochemical equivalents	967	Thermo-electric series	894
Electromotive force of different cells	852	VELOCITY of sound in gases	220
_____ series	839	_____ liquids	222
Endosmotic equivalents	129	_____ rocks	223
Expansion coefficients, of solids	305, 306	_____ solids	223
_____ liquids	314	_____ electric transmission	834
_____ gases	323	Volume elasticity	79
Eye, dimensions of	642	WAVE-LENGTHS	666
_____ refractive indices of media of	642	YOUNG'S modulus	80
FREEZING mixtures	339		
Fusing points of bodies	328, 329		
GLAISHER'S factors	398		
Gravity, force of, at various places	73		

LIST OF PLATES AND MAPS

TABLE OF SPECTRA	<i>Frontispiece</i>
COLOURED RINGS PRODUCED BY POLARISED LIGHT IN DOUBLE REFRACTING CRYSTALS	<i>To face p.</i> 692
ISOGNIC LINES FOR THE YEAR 1900	735
ISOCLINIC LINES FOR THE YEAR 1900	739
LINES OF HORIZONTAL FORCE FOR THE YEAR 1900	743
AURORA BOREALIS	1107
ISOTHERMAL FOR THE YEAR	1108
ISOTHERMAL FOR JANUARY	1110
ISOTHERMAL FOR JULY	1112

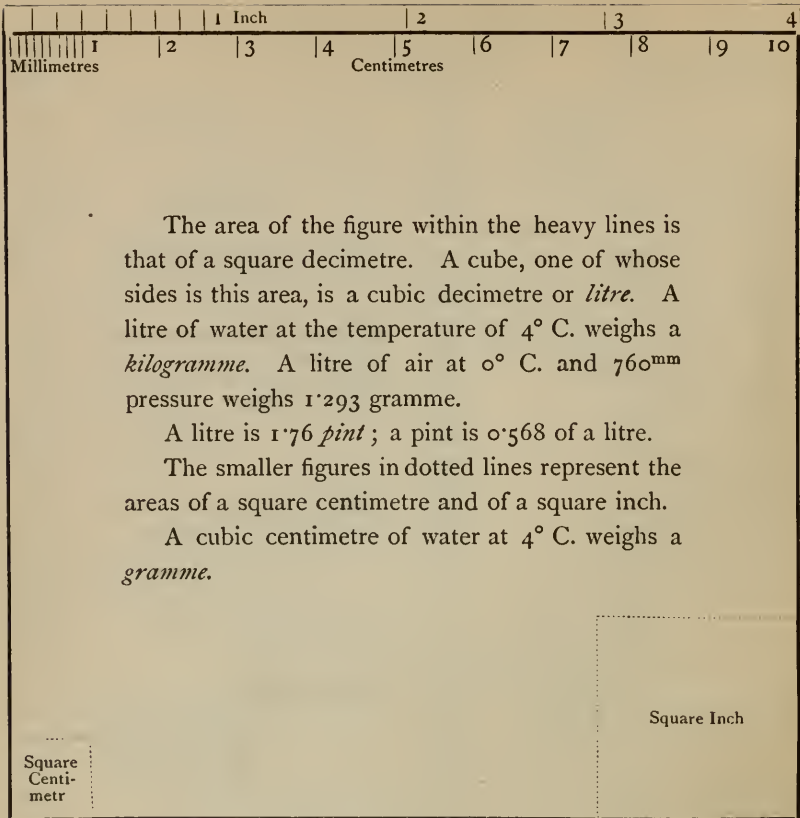

The area of the figure within the heavy lines is that of a square decimetre. A cube, one of whose sides is this area, is a cubic decimetre or *litre*. A litre of water at the temperature of 4° C. weighs a *kilogramme*. A litre of air at 0° C. and 760^{mm} pressure weighs 1.293 gramme.

A litre is 1.76 *pint* ; a pint is 0.568 of a litre.

The smaller figures in dotted lines represent the areas of a square centimetre and of a square inch.

A cubic centimetre of water at 4° C. weighs a *gramme*.

Square Centimetre

Square Inch

	Inches	Feet
Millimetre	0.03937	0.003281
Centimetre	0.39371	0.032809
Decimetre	3.93708	0.328090
Metre	39.37079	3.280899
Kilometre	39,370.80000	3,280.899167

A Hectare or 10,000 square metres is equal to 2.47114 acres, each of which is 43,560 square feet. A kilometre is 0.6214 of a statute mile. A statute mile is 1.609 kilometre. A knot is a velocity of 2,029 yards or 1.1528 statute miles per hour.

Measures of Capacity

	Cubic Inches	Cubic Feet
Cubic centimetre or millimetre	0.06103	1,728 c. in. = 1 c. ft. 0.000022
Litre or cubic decimetre	61.02705	0.035317
Kilolitre or cubic metre	61,027.05152	35.316581

Measures of Weight

	English Grains	Avoirdupois Pounds
Milligramme	0.01543	of 7,000 grains 0.000022
Gramme	15.43235	0.0022046
Kilogramme	15,432.34880	2.2046213

1 grain = 0.064799 gramme ; 1 pound avoirdupois is 0.453593 kilogramme.

CONTENTS

BOOK I

ON MATTER, FORCE, AND MOTION

CHAPTER	PAGE
I. GENERAL PRINCIPLES	1
II. GENERAL PROPERTIES OF BODIES	4
III. ON FORCE, EQUILIBRIUM, AND MOTION	14

BOOK II

ON GRAVITATION AND MOLECULAR ATTRACTION

I. GRAVITY. CENTRE OF GRAVITY. THE BALANCE	57
II. LAWS OF FALLING BODIES. INTENSITY OF TERRESTRIAL GRAVITY. THE PENDULUM	67
III. PROPERTIES PECULIAR TO SOLIDS	78

BOOK III

ON LIQUIDS

I. HYDROSTATICS	89
II. CAPILLARITY, ENDOSMOSE, DIFFUSION, AND ABSORPTION	117
III. HYDRODYNAMICS	133

BOOK IV

ON GASES

I. PROPERTIES OF GASES. ATMOSPHERE. BAROMETERS	145
II. MEASUREMENT OF THE ELASTIC FORCE OF GASES	163
III. PRESSURE ON BODIES IN AIR. BALLOONS	181
IV. APPARATUS WHICH DEPEND ON THE PROPERTIES OF AIR	186

BOOK V

ON SOUND

CHAPTER	PAGE
I. PRODUCTION, PROPAGATION, AND REFLECTION OF SOUND	209
II. MEASUREMENT OF THE NUMBER OF VIBRATIONS	231
III. THE PHYSICAL THEORY OF MUSIC	237
IV. VIBRATIONS OF STRETCHED STRINGS AND OF COLUMNS OF AIR	254
V. VIBRATION OF RODS, PLATES, AND MEMBRANES	269
VI. GRAPHICAL METHOD OF STUDYING VIBRATORY MOTIONS	273

BOOK VI

ON HEAT

I. PRELIMINARY IDEAS. THERMOMETERS	286
II. EXPANSION OF SOLIDS	302
III. EXPANSION OF LIQUIDS	311
IV. EXPANSION AND DENSITY OF GASES	318
V. CHANGES OF CONDITION. VAPOUR	328
VI. HYGROMETRY	392
VII. CONDUCTIVITY OF SOLIDS, LIQUIDS, AND GASES	402
VIII. RADIATION OF HEAT	411
IX. CALORIMETRY	446
X. STEAM AND OTHER HEAT ENGINES	469
XI. SOURCES OF HEAT AND COLD	491
XII. RELATION BETWEEN HEAT AND WORK	510

BOOK VII

ON LIGHT

I. TRANSMISSION, VELOCITY, AND INTENSITY OF LIGHT	520
II. REFLECTION OF LIGHT. MIRRORS	534
III. SINGLE REFRACTION. LENSES	552
IV. DISPERSION AND ACHROMATISM	578
V. OPTICAL INSTRUMENTS	604
VI. THE EYE CONSIDERED AS AN OPTICAL INSTRUMENT	639
VII. SOURCES OF LIGHT. PHOSPHORESCENCE	661
VIII. DOUBLE REFRACTION. INTERFERENCE. POLARISATION	666

BOOK VIII

ON MAGNETISM

CHAPTER	PAGE
I. PROPERTIES OF MAGNETS	704
II. METHODS OF MAGNETISATION	713
III. LAWS OF MAGNETIC ACTION	723
IV. TERRESTRIAL MAGNETISM	732

BOOK IX

ON FRICTIONAL ELECTRICITY

I. FUNDAMENTAL PRINCIPLES	750
II. QUANTITATIVE LAWS OF ELECTRIC ACTION. DISTRIBUTION	760
III. ELECTROSTATIC INDUCTION OR INFLUENCE. ELECTRIC MACHINES	774
IV. CONDENSATION OF ELECTRICITY	799

BOOK X

ON DYNAMICAL ELECTRICITY

I. VOLTAIC CELL. ITS MODIFICATIONS	835
II. MAGNETIC FIELD DUE TO A CURRENT. GALVANOMETERS	854
III. OHM'S LAW	866
IV. CONVERSION OF ELECTRIC ENERGY INTO HEAT	879
V. THERMO-ELECTRICITY	893
VI. ELECTRODYNAMICS	905
VII. ELECTROMAGNETS. MAGNETISATION OF IRON. TELEGRAPHS	924
VIII. ELECTRIC MEASUREMENTS	950
IX. ELECTROLYSIS	960
X. ELECTROMAGNETIC INDUCTION	985
XI. PASSAGE OF ELECTRICITY THROUGH GASES	1009
XII. MAGNETO- AND DYNAMO-ELECTRIC MACHINES	1026
XIII. DIAMAGNETISM	1041
XIV. CONNECTION BETWEEN ELECTRICITY AND LIGHT	1045
XV. PHYSIOLOGICAL ACTION OF THE CURRENT. ANIMAL ELEC- TRICITY	1066
ELEMENTARY OUTLINES OF METEOROLOGY AND CLIMATOLOGY	1072
PROBLEMS AND EXAMPLES IN PHYSICS	1115
INDEX	1149

ELEMENTARY TREATISE

ON

PHYSICS

BOOK I

ON MATTER, FORCE, AND MOTION

CHAPTER I

GENERAL PRINCIPLES

1. **Object of Physics.**—The object of *Physics* is the study of the phenomena presented to us by bodies. It should, however, be added that changes in the nature of the body itself, such as the decomposition of one body into others, are phenomena whose study forms the more immediate object of *chemistry*.

2. **Matter.**—That which possesses the properties whose existence is revealed to us by our senses, we call *matter* or *substance*.

All substances at present known to us may be considered as chemical combinations of about seventy *elementary* or *simple* substances. This number, however, may hereafter be diminished or increased by the discovery of some more powerful means of chemical analysis than we at present possess.

3. **Atoms, molecules.**—From various properties of bodies, we conclude that the matter of which they are formed is not perfectly continuous, but consists of an aggregate of an immense number of exceedingly small portions or *atoms* of matter. These atoms cannot be divided physically; they are retained side by side, without touching each other, being separated by distances which are great in comparison with their supposed dimensions.

A group of two or more atoms forms a *molecule*, so that a body may be considered as an aggregate of very small molecules, and these again as aggregates of still smaller atoms. The smallest masses of matter we ever obtain artificially are *particles*, and not molecules or atoms.

From considerations based upon various physical phenomena Lord Kelvin has calculated that in ordinary solids and liquids the average distance between contiguous molecules is less than the one hundred-millionth but greater than the one two thousand-millionth of a centimetre.

To form an idea of the degree of the size of the molecules Lord Kelvin gives this illustration : 'Imagine a drop of rain, or a glass sphere the size of a pea, magnified to the size of the earth, the molecules in it being increased in the same proportion. The structure of the mass would then be coarser than that of a heap of fine shot, but probably not so coarse as that of a heap of cricket-balls.'

The number of molecules in a cubic centimetre of air is calculated at twenty-one trillions.

By dissolving in alcohol a known weight of fuchsine, and diluting the liquid, it was observed that a solution containing not more than 0.00000002, or as it may conveniently be written 0.0₇2, of a gramme, in one cubic centimetre had still a distinct colour ; that is, that a quantity of not more than the $\frac{1}{50}$ -millionth of a gramme can be perceived by the naked eye. As the molecular weight of this substance is 337 times that of hydrogen, it follows that the mass of an atom of hydrogen cannot be greater than the one 20,000-millionth of a gramme. Weiner determined the thickness of a layer of silver at 0.2 $\mu\mu$, the expression μ standing for the thousandth of a millimetre, and $\mu\mu$ for the millionth of a millimetre or a *micromillimetre*.

Loschmidt gives the diameter of the molecules of hydrogen at 0.04 of a centimetre, or 0.4 $\mu\mu$; and according to Mousson and Quincke the diameter of the sphere within which one molecule can act upon an adjacent one, or what is called the *double radius of molecular action*, is between 30 and 40 $\mu\mu$, and is therefore from 10 to 20 times less than the wave-length of red light.

4. **Molecular state of bodies.**—With respect to the molecules of bodies three different stages of aggregation present themselves.

First, the solid state, as observed in wood, stone, metals, &c., at the ordinary temperature. The distinctive character of this state is, that the relative position of the molecules of the bodies is fixed and cannot be changed without the application of more or less force. Solid bodies tend, therefore, to retain whatever form may have been given to them by nature or by art.

Secondly, the liquid state, as observed in water, alcohol, oil, &c. Here the relative position of the molecules is no longer fixed, the molecules glide past each other with the greatest ease, and the body assumes with readiness the form of any vessel in which it may be placed.

Thirdly, the gaseous state, as in air and in hydrogen. In gases the mobility of the molecules is still greater than in liquids ; but the distinctive character of a gas is its incessant struggle to occupy a greater space, in consequence of which a gas has neither an independent form nor an independent volume, for its volume depends upon the pressure to which it is subject.

The general term *fluid* is applied to both liquids and gases.

Most simple bodies, and many compound ones, may be made to pass successively through all the three states. Water presents the most familiar example of this. Sulphur, iodine, mercury, phosphorus, and zinc are other instances.

5. **Physical phenomena, laws, and theories.**—Every change which can happen to a body, actual alteration of its chemical constitution being excepted, may be regarded as a *physical phenomenon*. The fall of a stone, the vibration of a string, and the sound which accompanies it, the attraction of

light particles by a rod of sealing-wax which has been rubbed by flannel, the rippling of the surface of a lake, and the freezing of water, are examples of such phenomena.

A *physical law* is the constant relation which exists between any phenomenon and its cause. As an example, we have the phenomenon of the diminution of the volume of a gas by the application of pressure; the corresponding law has been discovered, and is expressed by saying that *the volume of a gas is inversely proportional to the pressure if the temperature is constant.*

In order to explain the cause of whole classes of phenomena, suppositions, or *hypotheses*, are made use of. The utility and probability of an hypothesis or theory are the greater the simpler it is, and the more varied and numerous the phenomena which are *explained* by it; that is to say, are brought into regular causal connection among themselves and with other natural phenomena. Thus the adoption of the undulatory theory of light is justified by the simple and unconstrained explanation it gives of luminous phenomena, and by the connection it reveals with the phenomena of heat.

6. **Physical agents.**—In our attempts to ascend from a phenomenon to its cause, we assume the existence of *physical agents* or *natural forces* acting upon matter; as examples of such we have *gravitation, heat, light, magnetism, and electricity.*

Since these physical agents are disclosed to us only by their effects, their intimate nature is completely unknown. In the present state of science, we cannot say whether they are properties inherent in matter, or whether they result from movements impressed on the mass of subtile and imponderable forms of matter diffused through the universe. The latter hypothesis is, however, generally admitted. This being so, it may be further asked, are there several distinct forms of imponderable matter, or are they in reality but one and the same? As the physical sciences extend their limits, the opinion tends to prevail that there is a subtile, imponderable, and eminently elastic fluid called the *ether* distributed through the entire universe; it pervades the mass of all bodies, the densest and most opaque, as well as the lightest or the most transparent. It is also considered that the ultimate particles of which matter is made up are capable of definite motions varying in character and velocity, which can be communicated to the ether. A motion of a particular kind communicated to the ether can give rise to the phenomenon of heat; a motion of the same kind, but of greater frequency, produces light; and it is now pretty certain that a motion different in form or in character is the cause of electricity. Not merely do the atoms of bodies communicate motion to the atoms of the ether, but the latter can impart it to the former. Thus the atoms of bodies are at once the sources and the recipients of the motion. All physical phenomena, referred thus to a single cause, are but transformations of motion.

CHAPTER II

GENERAL PROPERTIES OF BODIES

7. **Different kinds of properties.**—By the term *properties*, as applied to bodies, we understand the different ways in which bodies present themselves to our senses. We distinguish *general* from *specific* properties. The former are shared by all bodies, and amongst them the most important are *impenetrability*, *extension*, *divisibility*, *porosity*, *compressibility*, *elasticity*, *mobility*, and *inertia*.

Specific properties are such as are observed in certain bodies only, or in certain states of these bodies ; such are *solidity*, *fluidity*, *tenacity*, *ductility*, *malleability*, *hardness*, *transparency*, *colour*, &c.

With respect to the above general properties, *impenetrability* and *extension* might, perhaps, be more aptly termed essential attributes of matter, since they suffice to define it ; while *divisibility*, *porosity*, *compressibility*, and *elasticity* do not apply to atoms, but only to bodies or aggregates of atoms (3).

8. **Impenetrability.**—*Impenetrability* is the property in virtue of which two portions of matter cannot at the same time occupy the same portion of space. Thus when a stone is placed in a vessel of water the volume of the water rises by an amount depending on the volume of the stone; this method, indeed, is used to determine the bulk of irregularly shaped bodies by means of graduated measures.

Strictly speaking, this property applies only to the atoms of a body. In many phenomena bodies appear to penetrate each other ; thus, the volume of a compound body is always less than the sum of the volumes of its constituents ; for instance, the volume of a mixture of water and sulphuric acid, or of water and alcohol, is less than the sum of the volumes before mixture. Two gases in the same space each occupies the whole of the space. In all these cases, however, the penetration is merely apparent, and arises from the fact that in every body there are interstices, or spaces unoccupied by matter (13).

9. **Extension.**—*Extension* or *Magnitude* is the property in virtue of which every body occupies a limited portion of space.

Many instruments have been invented for measuring linear extension or lengths with great precision. Two of these, the vernier and micrometer screw, on account of their great utility deserve to be here mentioned.

10. **Vernier.**—The *vernier* forms a necessary part of all instruments where lengths or angles have to be estimated with precision ; it derives its name from its inventor, a French mathematician, who died in 1637, and consists essentially of a short graduated scale, *ab* (fig. 1), which is made to

slide along a fixed scale, AB, so that the graduations of both may be compared with each other. The fixed scale, AB, being divided into equal parts, the whole length of the vernier, ab , may, for example, be taken equal to nine of those parts, and is itself divided into ten equal parts. Each of the parts of the vernier, ab , will then be less than a part of the scale by one-tenth of the latter.

This being granted, in order to measure the length of any object, mn , let us suppose that the latter, when placed as in the figure, has a length greater than four but less than five parts of the fixed scale. In order to determine by what fraction of a part mn exceeds four, one of the ends, a , of the vernier, ab , is placed in contact with one extremity of the object, mn , and the division on the vernier is sought which coincides with a division on the scale, AB. In the figure this coincidence occurs at the eighth division of the vernier, counting from the end, n , and indicates that the fraction to be measured is equal to $\frac{8}{10}$ ths of a part of the scale, AB. In fact, each of the parts of the vernier being less than a part of the scale by $\frac{1}{10}$ th of the latter, it is clear that on proceeding towards the left from the point of coincidence the divisions of the vernier are respectively one, two, three, &c. tenths,

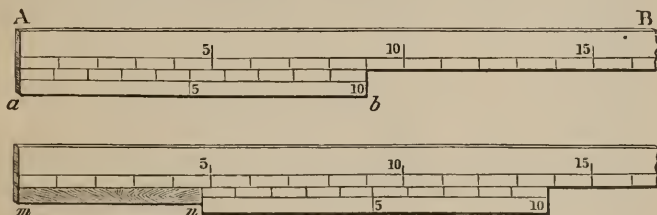

Fig. 1

behind the divisions of the scale ; so that the end, n , of the object (that is to say, the eighth division of the vernier) is $\frac{8}{10}$ ths behind the division 4 on the scale ; in other words, the length of mn is equal to $4\frac{8}{10}$ ths of the parts into which the scale AB is divided. Consequently if the scale AB were divided into inches the length of mn would be $4\frac{8}{10} = 4\frac{4}{5}$ inches. The divisions on the scale remaining the same, it would be necessary to increase the length of the vernier in order to measure the length mn more accurately. For instance, if the length of the vernier were equal to nineteen of the parts on the scale, and this length were divided into twenty equal parts, the length mn could be determined to the twentieth of a part on the scale, and so on. In instruments like the theodolite, intended for measuring angles, the scale and vernier have a circular form, and the latter usually carries a magnifier in order that the coincident divisions of vernier and scale may be determined with greater precision.

11. **Micrometer screw.**—Another useful little instrument for measuring small lengths with precision is the *micrometer screw*. It is used under various forms, but the principle is the same in all, and may be conveniently illustrated by reference to the *spherometer*. This consists of an accurately turned screw with a blunt point which works in a companion supported on three steel points (fig. 2). To one of these is fixed a vertical graduated scale, each division of which is equal to the distance between two threads of the screw.

This distance may be accurately determined by measuring a given length of the screw by compasses, and counting the number of the threads in this length. A circular disc attached to the screw is graduated at the periphery

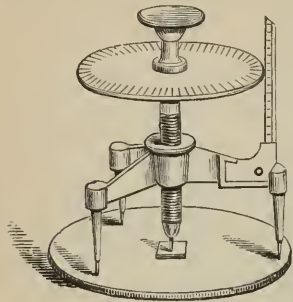

Fig. 2

into any given number of parts, say 500, and is turned by a milled head immediately above it. Suppose now the distance between the threads is 1 millimetre, when the head has made a complete turn the point of the screw will have risen or sunk through one millimetre, and so on in proportion for any multiple or fraction of a turn.

In order to determine the thickness of a piece of glass, for instance, the apparatus is placed on a perfectly plane polished surface, and the point of the screw is brought in contact with the glass. The division on the vertical scale immediately above the limb, and that on the limb are read off; each should read zero. After removing the glass plate the point is brought in contact with the plane surface, and corresponding readings are again made, from which the thickness can be at once deduced.

The same process is obviously applicable to determining the diameter of a wire.

To ascertain whether a surface is spherical, three points are applied to the surface, and the screw is also made to touch as described above. It is then moved along the surface, and if all four points are everywhere in contact the surface is truly spherical. This application is of great value in ascertaining the curvature of lenses.

The diameter of a sphere may also be measured by its means; for it can be shown by a simple geometrical construction that the distance of the movable point from the plane of the fixed points, multiplied by the diameter of the sphere, is equal to the square of the distance of the movable point from one of the fixed points. If h is the distance of the movable point from the plane of the fixed points, c the distance of the movable point from the fixed point when in the same plane, which is known once for all, and d the diameter of the sphere, then it can be shown by a simple geometrical construction that $d = \frac{c^2}{h} + h$ (see art. 539).

12. Divisibility.—*Divisibility* is the property in virtue of which a body may be separated into distinct parts.

Numerous examples may be cited of the extreme divisibility of matter (3). Leslie stated that the tenth part of a grain of musk will continue for years to fill a room with its odoriferous particles, and at the end of that time will scarcely be diminished in weight. Blood is composed of red, flattened globules, floating in a colourless liquid called *serum*. In man the diameter of one of these globules is less than the 3500th part of an inch, and the drop of blood which might be suspended from the point of a needle would contain about a million of globules.

Again, the microscope has disclosed to us the existence of insects smaller

than these particles of blood ; the struggle for existence reaches even to these little creatures, for they devour still smaller ones. If blood runs in the veins of these devoured ones, how infinitesimal must be the magnitude of its component globules !

Although experiment fails to determine whether there be a limit to the divisibility of matter, many facts in chemistry, such as the invariability in the relative weights of the elements which combine with each other, would lead us to believe that such a limit does exist. It is on this account that bodies are conceived to be composed of extremely minute and indivisible parts called *atoms* (3).

13. **Porosity.**—*Porosity* is the quality in virtue of which interstices or *pores* exist between the molecules of a body.

Two kinds of pores may be distinguished : *physical pores*, where the interstices are so small that the surrounding molecules remain within the sphere of each other's attracting or repelling forces ; and *sensible pores*, or actual cavities across which these molecular forces cannot act. The contractions and expansions resulting from variations of temperature are due to the existence of physical pores, whilst in the organic world the sensible pores are the seat of the phenomena of exhalation and absorption.

In wood, sponge, and a great number of stones—for instance, pumice stone—the sensible pores are apparent ; physical pores, or intermolecular spaces, never are. Yet, since the volume of every body may be diminished, we conclude that all possess physical pores.

The existence of sensible pores in leather or wood may be shown by the following experiment :—A long glass tube, A (fig. 3), is provided with a brass cup at the top, and a brass foot made to screw on to the plate of an air-pump. The bottom of the cup consists of a thick piece of leather. After pouring mercury into the cup so as entirely to cover the leather, the air-pump is put in action, and a partial vacuum produced within the tube. By this action a shower of mercury is at once produced within the tube, for atmospheric pressure forces the mercury through the pores of the leather. In the same manner water or mercury may be forced through the pores of wood by replacing the leather in the above experiment by a disc of wood cut perpendicular to the fibres.

When a piece of chalk is thrown into water, air-bubbles at once rise to the surface, in consequence of the air in the pores of the chalk being expelled by the water. The chalk will be found to be heavier after immersion than it was before, and, from its known volume, the volume of its pores may be easily determined from the increase of its weight.

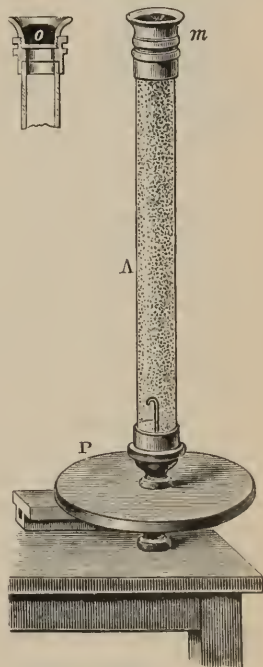

Fig. 3

The porosity of agate, flint, marble is evident from the fact that they are penetrated by liquids such as oil; on this, indeed, depends the artificial coloration of these minerals.

The porosity of gold was demonstrated by the celebrated Florentine experiment made in 1661. Some academicians at Florence, wishing to try whether water was compressible, filled a thin globe of gold with that liquid, and, after closing the orifice hermetically, they exposed the globe to pressure with a view of altering its form, knowing that any alteration in form must be accompanied by a diminution in volume. The consequence was, that the water forced its way through the pores of the gold, and stood on the outside of the globe like dew. More than forty years previously the same fact was demonstrated by Bacon by means of a leaden sphere; the experiment has since been repeated with globes of other metals, and similar results obtained. At a red heat both platinum and iron allow gases to diffuse through them.

Liquids have no pores in the ordinary sense of the word, but *intermolecular* spaces. As an illustration of this, a glass tube about a metre long, closed at one end, is half filled with water, and then pure alcohol poured upon it to a mark near the top; on then closing the open end with the thumb and inverting the tube several times the mixture shrinks so that its level is now nearly an inch below the mark; at the same time very minute bubbles are seen to rise, owing to the water having penetrated into the intermolecular spaces of the alcohol and expelled the air present.

14. Apparent and real volumes.—In consequence of the porosity of bodies, it becomes necessary to distinguish between their real and apparent volumes. The *real volume* of a body is the portion of space actually occupied by the matter of which the body is composed; its *apparent volume* is the sum of its real volume and the total volume of its pores. The real volume of a body is invariable, but its apparent volume can be altered in various ways.

15. Applications.—The property of porosity is utilised in filters of paper, felt, stone, charcoal, &c. The pores of these substances are sufficiently large to allow liquids to pass, but small enough to arrest the passage of any substances which these liquids may hold in suspension. Again, large blocks of stone are often detached in quarries by introducing wedges of dry wood into grooves cut in the rock. These wedges being moistened, water penetrates their pores, and causes them to swell with considerable force. Dry cords, when moistened, increase in diameter and diminish in length—a property of which advantage has been taken in order to raise great weights.

16. Cohesion.—*Cohesion* is the force which unites adjacent molecules of the same nature; for example, two molecules of water, or two molecules of iron. Cohesion is strongly exerted in solids, less strongly in liquids, and scarcely at all in gases. Its strength decreases as the temperature increases. Hence it is that when solid bodies are heated they first liquefy, and are ultimately converted into the gaseous state, provided that heat produces in them no chemical change.

In large masses of liquids the force of gravity overcomes that of cohesion. Hence liquids acted upon by the former force have no special shape; they take that of the vessel in which they are contained. But in smaller masses

cohesion gets the upper hand, and liquids assume then the spheroidal form. This is seen in the drops of dew on the leaves of plants. It is also seen when a liquid is placed on a solid which it does not moisten; as, for example, mercury upon wood. The experiment may also be made with water, by sprinkling upon the surface of the wood some light powder such as lycopodium or lampblack, and then dropping a little water on it. The following experiment is an illustration of the force of cohesion causing a liquid to assume the spheroidal form. A saturated solution of zinc sulphate is placed in a narrow-necked bottle (fig. 4), and a small quantity of carbon bisulphide, coloured with iodine, made to float on the surface. If pure water is now carefully added, so as to rest on the surface of the zinc sulphate solution, its specific gravity being less than that of the saturated solution, the bisulphide collects in the form of a flattened spheroid, which presents the appearance of blown coloured glass, and is larger than the neck of the bottle, provided a sufficient quantity has been taken.



Fig. 4

The force of cohesion of liquids may be illustrated and even measured as follows. A plane, perfectly smooth disc, *D* (fig. 5), is suspended horizontally to one scale-pan, *p*, of a delicate balance, and is accurately equipoised. A somewhat wide vessel of liquid is placed below, and the position of the disc regulated by means of the sliding screw *S* until it just touches the liquid. Weights are then carefully added to the other scale-pan until the disc is detached from the liquid. In this way it has been found that the weights required to detach the disc vary with the nature of the liquid; with a disc of 118 mm. diameter the numbers for water, alcohol, and turpentine were 59.4, 31, and 34 grammes respectively.

The results were the same whether the disc was of glass, of copper, or of other metals, showing thus that they only depend on the nature of the liquid. It is a measure of the cohesion of the liquid, for a layer remains adhering to the disc; hence the weight on the other side does not separate the disc from the liquid, but separates the particles of liquid from each other.

17. **Affinity.**—*Chemical affinity*, or *chemical attraction*, is the force which is exerted between molecules not of the same kind. Thus, in water, which is composed of oxygen and hydrogen, it is affinity which unites these elements, but it is cohesion which binds together two molecules of water.

To affinity are due all the phenomena of combustion and of chemical combination and decomposition.

Those causes which tend to weaken cohesion are most favourable to affinity; for instance, the action of affinity between substances is facilitated by their division, and still more by reducing them to a liquid or gaseous state. It is most powerfully exerted by a body in its *nascent* state—that is, the state in which the body exists at the moment it is disengaged from a compound; the body is then free and ready to obey the feeblest affinity. An increase of temperature modifies affinity differently under different circumstances. In some cases by diminishing cohesion, and increasing the distance between the molecules, heat promotes combination; thus, sulphur and oxygen, which at the ordinary temperature are without action on each other, combine to form sulphur dioxide when the temperature is raised. In other cases heat tends

to decompose compounds by imparting to their elements an unequal expansibility ; hence it is that many metallic oxides—as, for example, those of silver and mercury—are decomposed, by the action of heat, into gas and metal.

18. **Adhesion.**—The molecular attraction exerted between the *surfaces* of bodies in contact is called *adhesion*.

i. Adhesion takes place between solids. If two leaden bullets are cut with a penknife so as to form two equal and brightly polished surfaces, and the two faces are pressed and turned against each other, until they are in the closest contact, they adhere so strongly as to require a force of more than 100 grammes to separate them. The same experiment may be made with two equal pieces of glass which are polished and made perfectly plane. When they are pressed one against the other, the adhesion is so powerful that they cannot be separated without breaking. As the experiment succeeds *in vacuo*, it cannot be due to atmospheric pressure, but must be attributed to a reciprocal action between the two surfaces. The attraction also increases as the contact is prolonged, and is greater in proportion as the contact is closer.

It appears, however, from optical considerations that plates may be separated from each other by a distance of 0.0001 mm. As this is greater than the diameter of the sphere of molecular action (3), it is probable that the connection of the plates is affected by layers of air condensed on the surface (195).

In the operation of glueing the adhesion is complete, for the pores and crevices of the fresh surfaces being filled with liquid glue, so that there is no empty space on drying, wood and glue form one compact whole. In some cases the adhesion of cemented objects is so powerful that the mass breaks more readily at other places than at the cemented parts. Both in glueing and cementing the layer should be thin.

Spring exposed various powders, such as saltpetre, sawdust, fine sand, and chalk, to a pressure of 10,000 atmospheres (165). He thus obtained masses of greater hardness and tenacity than the original substances possessed, and destitute of crystalline form.

Soldering is due to adhesion ; the surface of the metals must be quite clean, which is effected by removing the layer of oxide, with which they are usually coated, by acid or by borax. The solder when it solidifies adheres only to clean metal surfaces.

There is no real difference between adhesion and cohesion ; thus when two freshly cut surfaces of indiarubber are pressed together, they adhere with considerable force, and ultimately form one compact solid mass.

ii. Adhesion also takes place between solids and liquids. If we dip a glass rod into water, and then withdraw it, a drop will be found to collect at its lower extremity, and remain suspended there. As the weight of the drop tends to detach it, there must necessarily be some force superior to this weight which maintains it there ; this force is the force of adhesion.

This is the cause why liquids when poured out of a vessel so easily run down the outside ; it is prevented by greasing the outer edge, and thus doing away with the adhesion.

The adhesion between a liquid and a solid is more powerful than that between solids. Thus, if in the above experiment a thin layer of oil is inter-

posed between the plates they adhere firmly, but when pulled asunder each plate is moistened by the oil, showing therefore that in separating the plates the cohesion of the liquid is overcome, but not the adhesion of the oil to the metal.

In the above case the solid is wetted by the liquid ; that is, some remains adhere even when the drop falls. But liquids adhere to solids even when they are not wetted. Thus, if a smooth glass plate is suspended horizontally from one arm of a balance, and is counterpoised as in fig. 5 ; on sliding a level surface of mercury under the plate, so that the plate touches the mercury, a considerable weight must be placed in the other pan so as to detach the plate from the mercury. Small drops of mercury, too, adhere to the under-side of a glass or porcelain plate.

iii. The force of adhesion operates, lastly, between solids and gases. If a glass or metal plate is immersed in water, bubbles will be found to appear on the surface. As air cannot penetrate into the pores of the plate, the bubbles could not arise from the air which has been expelled. It is solely due to the layer of air which covered the plate and *moistened* it like a liquid. In many cases when gases are separated in the *nascent state* on the surface of metals—as in electrolysis—the layer of gas which covers the plate has such a density that it can produce chemical actions more powerful than those which it can bring about in the free state.

The collection of dust on walls, writing and drawing with chalks and pencils, depend on the adhesion of solids. Yet these are easily rubbed out, for the adhesion is only to the surface layer. In writing with ink, and in water-colour painting, the liquid penetrates into the pores, taking the solid with it, which is left behind as the liquid evaporates, and hence the adhesion of such writing and painting is far more complete.

19. **Compressibility.**—*Compressibility* is the property in virtue of which the volume of a body may be diminished by pressure. This property is at once a consequence and a proof of porosity.

Bodies differ greatly with respect to compressibility. The most compressible bodies are gases ; by sufficient pressure they may be made to occupy ten, twenty, or even some hundred times less space than they do in ordinary circumstances. In most cases, however, there is a limit beyond which, when the pressure is increased, they cease to exist as gases and become liquefied.

The compressibility of solids is much less than that of gases, and is found in all degrees. Cloths, paper, cork, woods, are amongst the most compressible. Metals are so also to a great extent, as is proved by the process of coining, in which the metal receives the impression from the die. There

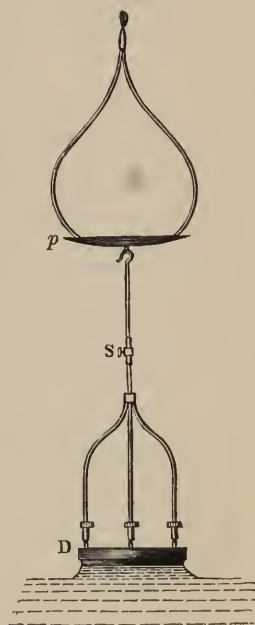

Fig. 5

is, in most cases, a limit beyond which, when the pressure is increased, bodies are fractured or reduced to powder.

The compressibility of liquids is so small as to have remained for a long time undetected ; it may, however, be proved by experiment, as will be seen in the chapter on Hydrostatics.

20. **Elasticity.**—*Elasticity* is the property owing to which bodies resist deformation, and resume their original form or volume when the force which altered that form or volume ceases to act. The existence of elasticity in bodies may be shown by pressure, by traction or pulling, flexure or bending, and by torsion or twisting. In treating of the *general* properties of bodies, elasticity of compression alone requires consideration ; the other kinds of elasticity, being peculiar to solid bodies, will be considered amongst their specific properties (arts. 85–93).

Gases and liquids are perfectly elastic in the sense that, after undergoing a change in volume, they regain exactly their original volume when the pressure becomes what it originally was. Solid bodies present different degrees of elasticity, though none present the property in the same perfection as liquids and gases, and in all it varies according to the time during which the body has been exposed to pressure. Ivory, glass, marble, and india rubber possess considerable elasticity ; lead, clay, and fats scarcely any.

There is a limit to the elasticity of solids, beyond which they either break or are incapable of regaining their original form and volume. This is called the *limit of elasticity* ; within this limit all substances are perfectly elastic. In sprains, for instance, the elasticity of the tendons has been exceeded. In gases and liquids, on the contrary, no such limit can be reached ; they always regain their original volume when the original pressure is restored.

If a ball of ivory, glass, or marble is allowed to fall upon a slab of polished marble, which has been previously slightly smeared with oil, it will rebound and rise to a height nearly equal to that from which it fell. On afterwards examining the ball a circular blot of oil will be found upon it, more or less extensive according to the height of the fall. From this we conclude that at the moment of the shock the ball was flattened, and that its rebound was caused by the effort to regain its original form.

21. **Mobility, motion, rest.**—*Mobility* is the property in virtue of which the position of a body in space may be changed.

Motion and rest may be either relative or absolute. By the *relative motion* or *rest* of a body we mean its change or permanence of position with respect to surrounding bodies ; by its *absolute motion* or *rest* we mean the change or permanence of its position with respect to ideal fixed points in space.

Thus a passenger in a railway carriage may be in a state of relative rest with respect to the train in which he travels, but he is in a state of relative motion with respect to the objects, such as trees, houses, &c., past which the train rushes. These houses again enjoy merely a state of relative rest, for the earth itself which bears them is in a state of incessant motion with respect to the celestial bodies of our solar system, inasmuch as it moves at the rate of more than eighteen miles in a second. In short, absolute

motion and rest are unknown to us ; in nature, relative motion and rest are alone presented to our observation.

22. **Inertia.**—*Inertia* is a purely negative though universal property of matter (26) ; it is the property in virtue of which matter cannot of itself change its own state of motion or of rest. If a body is at rest it remains so until some force acts upon it ; if it is in motion this motion can only be changed by the application of some force. The inertia of a body is the resistance which it opposes to any change of its state whether of rest or motion. This property of inertia is what is expressed by Newton's *first law of motion* (29).

A body, when unsupported in mid-air, does not fall to the earth in virtue of any inherent property, but because it is acted upon by the force of gravity. A billiard ball gently pushed does not move more and more slowly, and finally stop, because it has any preference for a state of rest, but because its motion is impeded by the friction against the cloth on which it rolls, and by the resistance of the air. If all impeding causes were withdrawn, a body once in motion would continue to move for ever in a straight line with unchanging velocity.

23. **Illustrations.**—Numerous phenomena may be explained by the inertia of matter. For instance, before leaping a ditch we run towards it, in order that the motion of our bodies at the moment of leaping may add itself to the muscular effort then made.

On descending carelessly from a carriage in motion, the upper part of the body retains its motion, whilst the feet are prevented from doing so by friction against the ground ; the consequence is we fall towards the moving carriage. A rider falls over the head of a horse if it suddenly stops. In striking the handle of a hammer against the ground the handle suddenly stops, but the head, striving to continue its motion, fixes itself more firmly on the handle.

By the property of inertia may also be explained the following experiments :—Let a card be placed upon a tumbler, and a shilling on the card ; if the edge of the card be smartly flicked with the finger the card is driven away and the coin falls into the tumbler. A gentle push with the finger will move a door on its hinges ; but if a pistol bullet is fired against the door it perforates the door without moving it. So, too, a pistol shot fired through a window-pane produces a sharp round hole, while a less violent shock will smash the pane. A clay tobacco-pipe, which is suspended by two vertical hairs, may be cut in two by a powerful stroke with a sharp sword without breaking the hairs.

A string which gently applied will raise a weight snaps at once when a sudden pull is exerted. Substances which explode with great rapidity, such as fulminating mercury and chloride of nitrogen, cannot be used with fire-arms, because there is not sufficient time to transfer the motion to the projectiles, and hence the weapons are burst.

The terrible accidents on our railways are chiefly due to inertia. When the motion of the engine is suddenly arrested the carriages strive to continue the motion they have acquired, and in doing so are shattered against each other. Hammers, pestles, stampers are applications of inertia. So are also the enormous iron fly-wheels, by which the motion of steam-engines is regulated.

CHAPTER III

ON FORCE, EQUILIBRIUM, AND MOTION

24. **Measure of time.**—To obtain a proper measure of force it is necessary, as a preliminary, to define certain conceptions which are presupposed in that measure; and, in the first place, it is necessary to define the unit of time. Whenever a *second* is spoken of without qualification, it is understood to be a second of *mean solar time*. The exact length of this unit is fixed by the following considerations. The instant when the sun's centre is on an observer's meridian—in other words, the instant of the *transit* of the sun's centre—can be determined with exactitude, and thus the interval which elapses between two successive transits also admits of exact determination, and is called an *apparent day*. The length of this interval differs slightly from day to day, and therefore does not serve as a convenient measure of time. Its *average* length is not open to this objection, and therefore serves as the required measure, and is called a *mean solar day*. The short hand of a common clock would go exactly twice round the face in a mean solar day if it went perfectly. The mean solar day consists of 24 equal parts called *hours*, these of 60 equal parts called *minutes*, and these again of 60 equal parts called *seconds*. Consequently, the second is the 86,400th part of a mean solar day, and is the generally received unit of time.

25. **Measure of space.**—Space may be either *length* or *distance*, which is space of one dimension; *area*, which is space of two dimensions; or *volume*, which is space of three dimensions. In England the standard of length is the British Imperial Yard, which is the distance between two fixed points on a certain metal rod, when the temperature of the whole rod is $60^{\circ} \text{ F.} = 15.5^{\circ} \text{ C.}$ It is, however, usual to employ as a unit a *foot*, which is the third part of a yard. The length of a seconds pendulum in London is 39.139 inches, and it was provided by the Act of Parliament which dealt with the standards that, in the event of the standard yard being lost or destroyed, a new one should be obtained by reference to the length of the seconds pendulum. The old standards were rendered useless by the fire which destroyed the Houses of Parliament in 1824, but the Commission which was appointed to reconstruct them did so, not by reference to the seconds pendulum, but by a comparison of the best copies of the old standard they could obtain. Thus, our present standard yard is a purely arbitrary length. If we take a foot as the unit of length, the unit of area is a square foot, and the unit of volume a cubic foot. This unit of volume is employed for many purposes, but for others a gallon, which is not simply related to a foot, is used. A gallon contains 277.274 cubic inches.

In the French system the metre is the primary unit of length, and was

originally so chosen as to be the ten-millionth part of the length of a quadrant of the meridian from either pole to the equator. In consequence, however, of errors in the measurement of the meridian, the French metre must now be looked upon as an arbitrary standard, not less so than the English yard. The standard metre, adopted by an International Committee for weights and measures, is constructed of an alloy of 90 per cent. platinum and 10 per cent. iridium, which is characterised by great hardness and unalterability. Its length is somewhat over a metre, and its cross section is represented in its natural size in figure 6. This shape has the advantage of giving great rigidity and of soon acquiring the temperature of the surrounding medium. The metric system is a decimal system. The metre contains 10 decimetres, 100 centimetres, and 1000 millimetres. Similarly for multiples of the metre; a decametre is equal to 10 metres, a hectometre 100 metres, and a kilometre 1000 metres. It will be noticed that Greek prefixes are used for multiples, and Latin prefixes for submultiples. The unit of capacity is either a cubic metre, or a cubic decimetre (called a litre), or a cubic centimetre.



Fig. 6

26. **Measure of mass.**—The mass of a body is that which remains unchanged in all the transformations which the body may undergo. Two bodies are said to have equal masses when, if placed in a perfect balance *in vacuo*, they counterpoise each other. Suppose we take lumps of any substance, lead, butter, wood, stone, &c., and suppose that any one of them when placed on the one pan of a balance will exactly counterpoise any other of them when placed on the opposite pan—the balance being perfect and the weighing performed *in vacuo*; this being the case, these lumps are said to have equal masses.

The British unit of mass is the standard pound (avoirdupois). It is the mass of a certain piece of platinum kept in the Exchequer Office in London. The pound avoirdupois contains 7000 grains. There is also another pound in use called a pound Troy, containing 5760 grains. The ounce avoirdupois is the sixteenth part of a pound avoirdupois and therefore contains 437.5 grains; the ounce Troy is the twelfth part of a pound Troy and contains 480 grains. The two ounces again are differently subdivided. The weights of precious metals are expressed in Troy weight; otherwise this system is little used. The confusion which may arise from the use of two different pounds disappears if the weights are expressed in grains, for the grain is common to both systems.

In the French system the unit of mass is called a *gramme*. It is the mass of a cubic centimetre of distilled water at 4° C. Thus the unit of mass is directly connected with the unit of length. There is no similar simple relation between the units of length and mass in the English system; a cubic inch of water weighs 252.5 grains.

The Latin and Greek prefixes deci, centi, milli, deca, hekto, kilo, are applied also to the gramme—as they may be to any other unit. Thus a milligramme is the thousandth part of a gramme, and a kilogramme is 1000 grammes, or is the mass of the litre of water at 4° C.

The relations between English and French units of length and mass and

their derivatives are given at the beginning of this book immediately before the Table of Contents.

27. **Density and relative density.**—If we consider any body or portion of matter, and if we conceive it to be divided into any number of parts having equal volumes, then, if the masses of these parts are equal, in whatever way the division is conceived as taking place, that body is one of *uniform density*. The *density* of such a body is the mass of the *unit of volume*. Consequently, if M denotes the mass, V the volume, and D the density of the body, we have

$$M = VD.$$

If now we have an equal volume V of any second substance whose mass is M' and density D' , we shall have

$$M' = VD'.$$

Consequently, $D:D'::M:M'$; that is, the densities of substances are in the same ratio as the masses of equal volumes of those substances. If now we take the density of distilled water at 4° C. to be unity, the relative density of any other substance is the ratio which the mass of any given volume of that substance at that temperature bears to the mass of an equal volume of water. Thus it is found that the mass of any volume of platinum is 20.337 times that of an equal volume of water, consequently the relative density of platinum is 20.337.

The relative density of a substance is generally called its *specific gravity*. Methods of determining it are given in Book III.

In the table below the densities D of various substances, expressed in pounds to the cubic foot, are given, and column G gives the relative densities of the same substances.

The column G is obtained by dividing the values in column D by 62.42, the mass of one cubic foot of water.

	D.	G.
Water	62.42	1.000
Anthracite	112.36	1.800
Cast iron	449.86	7.207
„ copper	548.55	8.788
„ lead	708.59	11.352
„ platinum	1,269.43	20.337
Melting ice	58.05	0.930

In the metric system, since the mass of the cubic centimetre of water is one gramme, it is evident that the density D , in grammes per cubic centimetre, has the same numerical value as the relative density referred to water. This is one of the great advantages which the French or metric system has over the British. If we wish to express the weight (P) in grains of a body whose volume is V cubic inches and density D , we must write $P = 252.5 DV$.

28. **Velocity and its measure.**—When a material point moves, it describes a continuous line which may be either straight or curved, and is called its *path* and sometimes its *trajectory*. Motion which takes place along a straight line is called *rectilinear* motion; that which takes place

along a curved line is called *curvilinear* motion. The rate of the motion of a point is called its *velocity*. Velocity may be either uniform or variable; it is *uniform* when the point describes equal spaces or portions of its path in all equal times; it is *variable* when the point describes unequal portions of its path in any equal times.

Uniform velocity is measured by the number of units of space described in unit of time. The units commonly employed in this country are feet and seconds. If, for example, a velocity 5 is spoken of without qualification, this means a velocity of 5 feet per second. Consequently, if a body moves for t seconds with a uniform velocity v , it will describe vt feet.

The following are a few examples of different degrees of velocity expressed in this manner. A snail 0.005 feet in a second; the Rhine between Worms and Mainz 3.3; military quick step 4.6; moderate wind 10; fast sailing vessel 18.0; Channel steamer 22.0; railway train 36 to 90 feet; racehorse and storm 50 feet; ocean wave in a gale 46 and in a tempest 72 feet; eagle 110 feet; carrier pigeon 120 feet; a hurricane 160 feet; sound at 0° C. 1090; a shot from an Armstrong gun 1180; a Martini-Henry rifle bullet 1330; a point on the Equator, in its rotation about the earth's axis 1520; maximum tide rate 3005; velocity of the centre of the earth 101,000 feet; light, and also electricity 186,000 miles. Air is called still when it is really moving a mile to a mile and a half per hour; the average rate in England is 6 to 8 miles.

Variable velocity is measured at any instant by the number of units of space a body would describe if it continued to move uniformly from that instant for a unit of time. Thus, suppose a body to run down an inclined plane, it is a matter of ordinary observation that it moves more and more quickly during its descent; suppose that at any point it has a velocity 15, this means that at that point it is moving at the rate of 15 feet per second, or, in other words, if from that point all increase of velocity ceased, it would describe 15 feet in the next second.

29. **Force.**—Forces manifest themselves to us by the changes which they produce, or tend to produce, in the motion of matter. The action of forces in causing motion is best expressed in Newton's laws: The first law is, *Every body continues in its state of rest or of uniform motion in a straight line, except as it is compelled by forces to change that state.*

A body may be at rest, or may be moving uniformly in a straight line, while acted upon by a system of forces. In this case the forces are said to balance each other. If a constant unbalanced force act upon a body, it will no longer move uniformly. The velocity will increase continually, at a uniform rate. A familiar case of this kind is found in the attraction of the earth for other bodies. According to Newton's law of gravitation, the attraction between two masses, one of which contains m and the other m' units of mass, is $G \frac{mm'}{r^2}$ (68), where r is the distance between the centres of the masses and G is a constant called the *Newtonian constant of gravitation*. If one of the masses is the unit mass, or one pound, the other being the earth, the above expression represents the pull which the earth exerts upon a pound of matter: this pull is the weight of a pound.

It is important to distinguish very carefully between a pound—the unit

of mass—and the weight of a pound, which is a *force*. Weight is not a necessary property of matter. If physical conditions were such that we could visit the centre of the earth, we should find matter without weight, although its other properties would remain unchanged. A bullet fired from a gun, although weightless, would have the same effect as at the surface of the earth, this effect being dependent, as will be shown, upon the amount of matter (mass) in the bullet and the velocity imparted, and having no relation whatever to the weight of the bullet. A pound of sugar at the centre of the earth would have precisely the same sweetening properties as at the surface. The commercial value of provisions, drugs, &c., is therefore strictly proportional to the number of units of mass purchased, and has no necessary relation to the weights of those masses.

It is also to be observed that, if masses are counterpoised on a lever balance at any one locality, they will remain balanced at any other point, since the weights of the masses will change in the same ratio. Hence the lever balance with standard ‘weights’ really measures the mass of a body, and not its weight, and the standard ‘weights’ should really be called masses. A spring balance determines weight and not mass, since its indications change as the weight of the mass changes.

At the centre of the earth, masses could not be determined by means of a balance, since they weigh nothing, and any mass would counterpoise any other mass.

30. Measure of force.—In devising a unit in which to measure force, it is most convenient to make use of the attractive force of the earth. Suppose that two equal masses, P , are balanced on a pulley with fixed axle, that the string and pulley are without mass, and that there is no friction or air-resistance. The masses P are then perfectly inert. The tension on the string is the pull of the earth on *one* of the masses P , or, in other words, the weight of P . If the pulley is set in motion by a force which then ceases to act, the masses will thereafter move uniformly according to the first law of motion, the tension on the string being, as before, the weight of P .

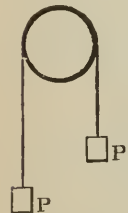

Fig. 7

This will all be true, whatever may be the amount of matter in the masses P . But if, the masses P being at rest, an additional mass m is placed on one side, the system will begin to move. The tension on the string is now greater than the weight of P and less than the weight of $P + m$. The force which causes the motion is the pull of the earth on m , or the weight of the added mass. The motion is uniformly accelerated. At the instant of starting, the velocity is zero. At the end of the first second, the velocity will be—say f ; at the end of the second second, $2f$; and at the end of t seconds, the velocity will be ft .

The increase in the velocity per second is f , which is called the *acceleration*.

If the mass m is entirely disconnected from the masses P and allowed to fall freely, it also falls with a uniformly accelerated motion; but experiment shows that the acceleration is greater than in the former case. This acceleration of a freely falling body is usually denoted by g . The force which causes the motion is, however, the same as before, being the weight of m . The difference in the two cases is, that, in the latter case, the pull of the earth on m is employed in setting in motion the mass m only; while, in

the former case, the two inert masses P are attached to m , and are constrained to move with it, the mass to be moved being thus increased without a corresponding increase of the force employed in moving.

It is evident that if the masses P should diminish to zero, or the mass m should increase until it became very large, the weight of m would impart a greater and greater acceleration, until finally the acceleration would become g . On the other hand, if the masses P should become very large, or the mass m very small, or zero, the acceleration would become zero. It is shown by experiment that if the mass m is made n times as great (so that the moving force is n times as great), and the masses P are equally diminished—so that $2P + m$ is unchanged—the acceleration becomes n times as great, so that the mass to be moved being unchanged, the acceleration is directly proportional to the force applied. If, however, the mass m is made n times as great, and it is desired to have the acceleration remain unchanged, it is found that the masses P must be equally increased in such a way that $2P + m$ has also become n times as great. This shows that, the acceleration remaining constant, the force applied must change in the same ratio as the mass.

From these experiments it follows that if any force F is applied in giving uniformly accelerated motion to a mass M , the acceleration being f , then

$$F = KMf.$$

Here M is measured in pounds, and the acceleration f measures the change in velocity of M in feet per second. K is a constant, the numerical value of which will depend upon the unit which we adopt in which to measure F . If, as is customary, we adopt as the unit force that force which will make $f = 1$ when $M = 1$, then we at the same time necessarily make the remaining quantity K in the last equation equal to 1; and measured in these units,

$$F = Mf.$$

The unit force is then that force which can impart unit acceleration (one foot per second in every second), to unit mass (one pound). It is called a *poundal*.

If V represents the initial velocity of a body, and v its final velocity, the change in velocity having taken place in t seconds, then the change per second is

$$f = \frac{-vV}{t}.$$

This value of f introduced in the previous equation gives

$$F = \frac{Mv - MV}{t}.$$

31. **Momentum.**—It thus appears that the number of units of force in any force which, acting for t seconds on a mass M , is capable of changing its velocity from V to v , is measured by the change per second in the product Mv . This quantity Mv , being thus an important one, has received a special name—*momentum*. We may now say that the number of units in a force is

measured by the change in momentum which it can produce per second, which is the substance of Newton's *second law of motion*.

32. **Acceleration of gravity.**—At London, the force with which the earth attracts a pound of matter is capable of imparting to the pound an acceleration of 32·1912 in feet and seconds. At other places the acceleration is different, and may be denoted by g . Hence, at London, the weight of a pound, expressed in the units which we have chosen for measuring forces, will be 32·1912. At any other point on the earth, or in the interior of the earth, or at any point outside, where the acceleration of a falling body is g , the number of units of force in the weight of a pound is g . The number w of units of force in the weight of m pounds is given by the equation

$$w = mg.$$

If at some point where the acceleration is 32 it is found that the weight of 10 lb., or 320 units of force, is sufficient to serve as the driving-weight to a certain clock, then at some other point, where the acceleration is 16, it would be necessary to use the weight of 20 lb. in order to secure the same effect.

Since a poundal acting on the mass of a pound imparts to it a velocity of one foot per second in every second, and a pound falling freely (the force acting on it being its own weight) acquires a velocity of 32·19 feet per second in every second, we see that a pound-weight is equal to 32·19 poundals at London, or a poundal is the weight of about half an ounce. Where great accuracy is not required, it is customary to take the weight of the pound as the unit of force, and then the intensity of the force is given in pounds weight, a unit which varies slightly for different places on the earth, as g varies. In like manner, for ordinary purposes, a land surveyor does not find it necessary to make corrections for the varying length of his chain due to changes in temperature, although such corrections are highly important in the more refined operations of a geodetic survey.

Pendulum observations (81) show that at any given place the acceleration of a falling body is constant, but it is found to have different values at different places; adopting the units of feet and seconds it is found that very approximately

$$g = g'(1 - 0\cdot00256 \cos 2\phi),$$

at a station whose latitude is ϕ , where g' denotes the number 32·1724, or the value of g at lat. 45° .

Experience teaches that in all cases where a force is exerted there must be *two* bodies, between which the force acts. Newton's *third law of motion* asserts that the mutual action of the two bodies is always equal and oppositely directed.

The attraction of the earth for m pounds of matter is mg , where g is the acceleration of the body. The attraction of the m pounds for the earth is Mf , where M is the mass of the earth in pounds, and f is the acceleration with which it moves towards m . According to the third law of motion

$$Mf = mg.$$

If m is a small body like a few thousand pounds, then, since the mass of the earth is very large, the acceleration of the earth will be inappreciable

If m and M were equal, f and g would be equal. Remembering that the acceleration is the change per second in the velocity, if the two bodies move towards each other for t seconds, the initial velocities being V_1 and V_2 and the final velocities v_1 and v_2 , the above expression becomes

$$Mv_1 - MV_1 = \frac{mv_2 - mV_2}{t}$$

As t divides out of this equation, it will follow that the two bodies which mutually attract each other will suffer equal changes of momenta in the same time. If the two bodies start from rest at the same instant, so that V_1 and V_2 are zero, then

$$Mv_1 = mv_2,$$

or they will have equal momenta at the same instant. The momenta of a freely suspended rifle and of a bullet fired from it will be equal so long as the ball is in the barrel. If the rifle is supported, the supporting body must be included with the rifle in the value M .

33. Representation of forces.—Draw any straight line AB (fig. 8) and fix on any point O in it. We may suppose a force to act on the point O , along the line AB , either towards A or B : then O is called the *point of application* of the force, AB its line of action; if it acts towards A , its *direction* is OA , if towards B , its direction is OB . It is rarely necessary to make the distinction between the line of action and direction of a force; it being very convenient to make the convention that the statement—a force acts on a point O along the line OA —means that it acts from O to A . Let us suppose the force which acts on O along OA to contain P units of force: from O towards A measure ON , containing P units of length, the line ON is said to *represent* the force. The analogy between the line and the force is very complete: the line ON is drawn from O in a given direction OA , and contains a given number of units P , just as the force acts on O in the direction OA , and contains a given number of units P . It is scarcely necessary to add, that if an equal force were to act on O in the opposite direction, it would be said to act in the direction OB , and would be represented by OM , equal in magnitude to ON .

When we are considering several forces acting along the same line we may indicate their directions by the positive and negative signs. Thus the forces mentioned above would be denoted by the symbols $+P$ and $-P$ respectively.

34. Forces acting along the same line.—If forces act on the point O in the direction OA equal to P and Q units respectively, they are equivalent to a single force R containing as many units as P and Q together—that is,

$$R = P + Q.$$

If the sign $+$ in the above equation denotes *algebraical* addition, the equation will continue true whether one or both the forces act along OA or OB . It is plain that the same rule can be extended to any number of forces, and if several forces have the same line of action, they are equivalent to one force containing the same number of units as their *algebraical* sum. Thus, if

forces of 3 and 4 units act on O in the direction OA, and a force of 8 in the direction OB, they are equivalent to a single force containing R units given by the equation

$$R = 3 + 4 - 8 = -1;$$

that is, R is a force containing one unit acting along OB. This force R is called their *resultant*. If the forces are in equilibrium, R is equal to zero. In this case the forces have equal tendency to move the point O in opposite directions.

35. **Resultant and components.**—In the last article we saw that a single force R could be found equivalent to several others; this is by no means peculiar to the case in which all the forces have the same line of action; in fact, when a material point, A (fig. 9), remains in equilibrium under the action of several forces, S, P, Q, it does so because any one of the forces, as S, is capable of neutralising the combined effects of all the others. If the force S, therefore, had its direction reversed, so as to act along AR, the prolongation of AS, it would produce the same effect as the system of forces P, Q.

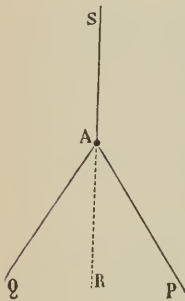

Fig. 9

Now, a force whose effect is equivalent to the combined effects of several other forces is called their *resultant*, and with respect to this resultant, the other forces are termed *components*.

When the forces P, Q act on a point, they can only have *one* resultant; but any single force can be resolved into components in an indefinite number of ways.

If a point moves from rest, under the action of any number of forces, it will begin to move in the direction of their resultant.

36. **Parallelogram of forces.**—When two forces act on a point their resultant is found by the following theorem, known as the principle of the parallelogram of forces:—*If two forces act on a point, and if lines are drawn from that point representing the forces in magnitude and direction, and if a parallelogram is constructed on these lines as sides, their resultant will be represented in magnitude and direction by that diagonal which passes through the point.* Thus let P and Q (fig. 10) be two forces acting on the point A along AP and AQ respectively, and let AB and AC be taken containing the same number of units of length that P and Q contain units of force; let the parallelogram ABDC be completed, and the diagonal AD drawn; then the theorem states that the resultant, R, of P and Q is represented by AD; that is to say, P and Q together are equal to a single force R acting along the line AD, and containing as many units of force as AD contains units of length.

Proofs of this theorem are given in treatises on Mechanics; we will here give an account of a direct experimental verification of its truth; but before doing so we must premise an account of a very simple experiment.

Let A (fig. 11) be a small pulley, and let it turn on a smooth, hard, and thin axle, with little or no friction; let W be a weight tied to the end of a fine thread which passes over the pulley; let a spring CD be attached by one end to the end C of the thread and by the end D to another piece of

thread, the other end of which is fastened to a fixed point B ; a scale CE can be fastened by one end to the point C and pass inside the spring so that the elongation of the spring can be measured. Now it will be found on trial that with a given weight W the elongation of the spring will be the same whatever the angle contained between the parts of the string WA and BA.

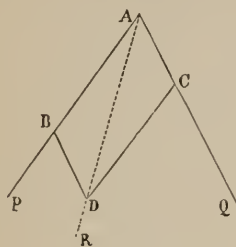

Fig. 10

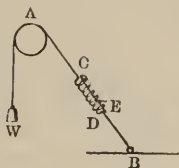

Fig. 11

Also it would be found that if the whole were suspended from a fixed point, instead of passing over the pulley, the weight would in this case stretch the string to the same extent as before. This experiment shows that when care is taken to diminish to the utmost the friction of the axle of the pulley, and the imperfect flexibility of the thread, the weight of W is transmitted without sensible diminution to B, and exerts on that point a pull or force along the line BA virtually equal to W.

This being premised, an experimental proof, or illustration, of the parallelogram of forces may be made as follows :—

Suppose H and K (fig. 12) to be two pulleys with axles made as smooth and fine as possible ; let P and Q be two weights suspended from fine and flexible threads which, after passing over H and K, are fastened at A to a third thread AL, from which hangs a weight R ; let the three weights come to rest in the positions shown in the figure. Now the point A is acted on by three forces in equilibrium—viz. P from A to H, Q from A to K, and R from A to L ; consequently any one of them must be equal and opposite to the resultant of the other two. Now if we suppose the apparatus to be arranged immediately in front of a large slate, we can draw lines upon it coinciding with AH, AK, and AL. If now we measure off along AH the part AB containing as many inches as P contains pounds, and along AK the part AC containing as many inches as Q contains pounds, and complete the parallelogram ABDC, it will be found that the diagonal AD is in the same line as AL, and contains as many inches as R weighs pounds. Consequently, the resultant of P and Q is represented by AD. Of course, any other units of length and force might have been employed. Now it will be found that when P, Q, and R are changed in any way whatever, consistent with equilibrium, the same construction can be made—the point A will have different positions in the different cases ; but when equilibrium is established and the parallelogram

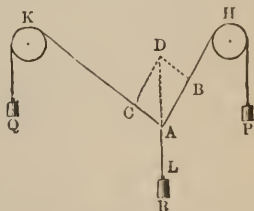

Fig. 12

ABDC is constructed, it will be found that AD is vertical, and contains as many units of length as R contains units of force, and consequently it represents a force equal and opposite to R—that is, it represents the resultant of P and Q.

37. **Resultant of any number of forces acting in one plane on a point.**—Let the forces P, Q, R, S (fig. 13) act on the point A, and let them be represented by the lines AB, AC, AD, AE, as shown in the figure. *First*, complete the parallelogram ABFC and join AF; this line represents the resultant of P and Q. *Secondly*, complete the parallelogram AFGD and join AG; this line represents the resultant of P, Q, R. *Thirdly*, complete the parallelogram AGHE and join AH; this line represents the resultant of P, Q, R, S. It is manifest that the construction can be extended to any number of forces. A little consideration will show that the line AH might be determined by the following construction:—Through B draw BF parallel to, equal to, and towards the same part as AC; through F draw FG parallel to, equal to, and towards the same part as AD; through G draw GH parallel to, equal to, and towards the same part as AE; join AH, then AH represents the required resultant.

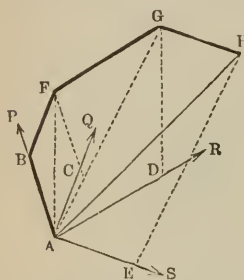

Fig. 13

38. **Triangle of forces.**—If the resultant of the forces is zero, they have no joint tendency to move the point, and consequently are in equilibrium.

The case of three forces acting on a point is of such importance that we may give a brief statement of it. Let P, Q, R (fig. 14) be three forces in equilibrium on the point O.

From any point B draw BC parallel to and towards the same part as OP, from C draw CA parallel to and towards the same part as OQ, and take CA such that $P : Q :: BC : CA$; then on joining AB, the third force R must act along OR parallel to and towards the same part as AB, and must be proportional in magnitude to AB. This construction is frequently called the *Triangle of Forces*. It is evident that while the sides of the triangle are severally proportional to P, Q, R, the angles A, B, C are supplementary to QOR, ROP, POQ respectively; consequently, every trigonometrical relation existing between the sides and angles of ABC will equally exist between the forces P, Q, R, and the supplements of the angles between their directions. Thus in the triangle ABC it is known that the sides are proportional to the sines of the opposite angles; now,

since the sines of the angles are equal to the sines of their supplements, we at once conclude that *when three forces are in equilibrium, each is proportional to the sine of the angle between the directions of the other two.*

39. **Moments of forces.**—Let P (fig. 15) denote any force acting from B to P', take A any point, let fall AN perpendicular from A on BP. The product of the number of units of force in P, and the number of units of length in AN, is called the moment of P with respect to A. Since the force P can be represented by a straight line, the moment of P can be represented

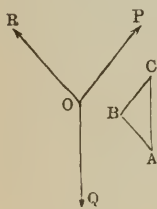

Fig. 14

by an area. In fact, if BC is the line representing P, the moment is properly represented by twice the area of the triangle ABC. The perpendicular AN is sometimes called the arm of the force. Now if a watch were placed with its face upwards on the paper, the force P would cause the arm AN to turn round A in the *contrary* direction to the hands of the watch. In these circumstances, it is usual to consider the moment of P with respect to the point A to be positive. If P acted from C to B, it would turn NA in the *same* direction as the hands of the watch, and now its moment is reckoned *negative*.

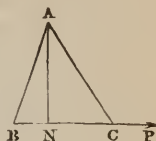

Fig. 15

It is a simple geometrical consequence of the parallelogram of forces (36) that the moment of the resultant equals the sum of the moments of the component forces, regard being had to the *signs* of the moments.

If the point about which the moments are measured is taken in the direction of the resultant, its moment with respect to that point will be zero; and consequently the sum of the moments with respect to such point will be zero.

40. **Composition and resolution of parallel forces.**—The case of the equilibrium of three parallel forces is merely a particular case of the equilibrium of three forces acting on a point. In fact, let P and Q be two forces whose directions pass through the points A and B, and intersect in O, fig. 16; let them be balanced by a third force R whose direction produced intersects the line AB in C. Now suppose the point O to move along AO, gradually receding from A, the magnitude and direction of R will continually change, and also the point C will continually change its position, but will always lie between A and B. In the limit P and Q become parallel forces acting towards the same part, balanced by a parallel force R acting towards the contrary part through a point X between A and B. The question is:—*First*, in this limiting case, what is the value of R; *secondly*, what is the position of X? Now with regard to the first point it is plain that if a triangle *abc* is drawn as in art. 38, the angles *a* and *b* in the limit will vanish, and *c* will become 180°, consequently *ab* ultimately equals *ac + cb*;

or
$$R = P + Q.$$

With regard to the second point, it follows from the last article (39) that the moments of P and Q about C are always equal, whence

$$AX : XB :: Q : P,$$

a proportion which determines the position of X. Hence the following rules for the composition of any two parallel forces, viz.—

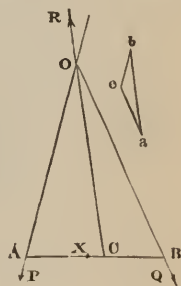

Fig. 16

I. When two parallel forces P and Q act towards the same part, at rigidly connected points A and B, their resultant is a parallel force acting towards the same part, equal to their sum, and its direction divides the line AB into two parts AC and CB inversely proportional to the forces P and Q.

II. When two parallel forces P and Q, of which P is the greater, act towards contrary parts at rigidly connected points A and B, their

resultant is a parallel force acting towards the same part as P, equal to the excess of P over Q, and its direction divides BA produced in a point C such that CA and CB are inversely proportional to P and Q.

In each of the above cases if we were to apply R at the point C, in opposite directions to those shown in the figure, it would plainly (by the above theorem) balance P and Q, and therefore when it acts as shown in figs. 17 and 18 it is the resultant of P and Q in those cases respectively. It will, of course, follow that the force R acting at C can be resolved into P and Q acting at A and B respectively.

If the second of the above theorems is examined, it will be found that no force R exists equivalent to P and Q when these forces are equal. Two such forces constitute a *couple*, which may be defined to be two equal parallel forces acting towards contrary parts; a couple possesses the remarkable property that it is incapable of being balanced by any single force whatsoever.

Thus, when a couple is applied to a body, a motion of rotation is produced, not a motion of translation. A compass needle when deflected from the magnetic meridian is acted on by a couple due to the earth's magnetism.

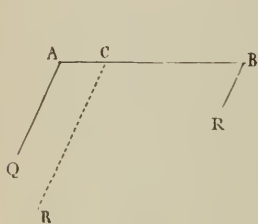

Fig. 17

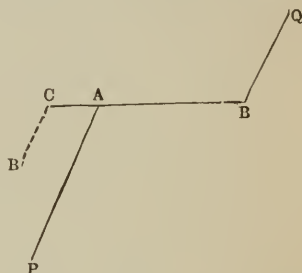

Fig. 18

The needle has no tendency to move away from its place. A couple is required to twist a wire, turn a capstan, &c.

In the case of more than two parallel forces the resultant of any two can be found, then of that and a third, and so on to any number; it can be shown that however great the number of forces they will either be in equilibrium or will reduce to a single resultant or to a couple.

41. **Centre of parallel forces.**—On referring to figs. 17 and 18, it will be remarked that if we conceive the points A and B to be fixed, and the directions AP and BQ of the forces P and Q to be turned round A and B, so as to continue parallel and to make any angle with their original directions, then the direction of their resultant will continue to pass through C; that point is therefore called *the centre* of the parallel forces P and Q.

It appears from investigation that whenever a system of parallel forces reduces to a single resultant, those forces will have a centre; that is to say, if we conceive each of the forces to act at a fixed point, there will be a point through which the direction of their resultant will pass when the directions of the forces are turned through any equal angles round their points of application in such a manner as to retain the parallelism of their directions.

The most familiar example of a centre of parallel forces is the case in which the forces are the weights of the parts of a body ; in this case the forces all acting towards the same part will have a resultant, viz. their sum ; and their centre is called the *centre of gravity* of the body

42. **Equality of action and reaction.**—We will proceed to exemplify some of the principles now laid down by investigating the conditions of equilibrium of bodies in a few simple cases ; but before doing so we refer again to the law stated in art. 32, which holds good whenever a mutual action is called into play between two bodies. *Reaction is always equal and contrary to action : that is to say, the mutual actions of two bodies on each other are always equal in amount and opposite in direction,* and this is equally true when the bodies are in motion and when they are at rest. A very instructive example of this law has already been given (36), in which the action on the spring CD (fig. 11) is the weight W transmitted by the spring to C, and balanced by the reaction of the ground transmitted from B to D. In these circumstances the spring is said to be stretched by a force W. If the spring were removed, and the thread were continuous from A to B, it is clear that any part of it is stretched by two equal forces, viz. an action and reaction, each equal to W, and the thread is said to sustain a tension W. When a projectile is fired from a gun, the action is the momentum of the projectile, the reaction is the recoil of the gun—its momentum in the opposite direction, and Newton's third law states the equality of the two momenta. When a horse draws a barge with uniform velocity along a canal, the pull on the rope is the same in whichever direction we regard it ; that is, the force with which the horse pulls the barge is equal to that with which the barge pulls the horse. If the former were greater there would be acceleration, and the barge would approach the horse. Were the horse to do no work, the barge would speedily be brought to rest by friction, resistance of air and water, &c. The work spent by the horse overcomes this tendency and maintains the tension of the rope constant. It is the roughness, and consequent friction, of the ground which enables the horse to do this work.

43. **The lever** is a name given to any bar, straight or curved, AB (fig. 19), resting on a fixed point or edge *c* called the *fulcrum*. The forces acting on the lever are the *weight* or resistance *Q*, the *power* *P*, and the reaction of the fulcrum. Since these are in equilibrium, the resultant *P* and *Q* must act through *c*, for otherwise they could not be balanced by the reaction. Draw *cb* at right angles to *QB* and *ca* to *PA* produced ; then, observing that $P \times ca$ and $Q \times cb$ are the moments of *P* and *Q* with respect to *c* and that they have contrary signs, we have (by 39)

$$P \times ca = Q \times cb ;$$

an equation commonly expressed by the rule that *in the lever the power is to the weight in the inverse ratio of their arms*.

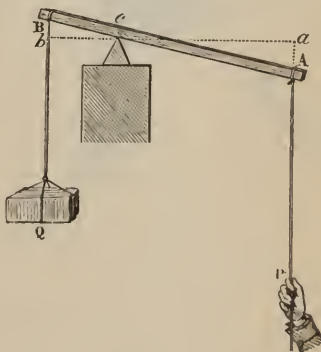

Fig. 19

Levers are divided into three kinds, according to the position of the fulcrum with respect to the points of application of the power and the weight. In a *lever of the first kind* the fulcrum is between the power and resistance, as in fig. 19, and as in a poker and in the common steelyard; a pair of scissors and a carpenter's pincers are double levers of this kind. In a *lever of the second kind* the resistance is between the power and the fulcrum, as in a wheelbarrow, or a pair of nutcrackers, or a door; in a *lever of the third kind* the power is between the fulcrum and the resistance, as in a pair of tongs or the treadle of a lathe.

44. **Pulleys.**—The pulley is a hard circular disc of wood or of metal in the edge of which is a groove, and which can turn freely on an axis in the centre. Pulleys are either *fixed*, as in fig. 20, where the stirrup or fork is rigidly connected with some immovable body, and where the axis rotates in the stirrup; or it may be movable, as in fig. 21, where the axis is fixed to the fork, and it passes through a hole in the centre of the disc. The rope which passes round the pulley in fig. 20 supports a weight at one end; while at the other a pull is applied to hold this weight in equilibrium.

We may look upon the power and the resistance as acting at the circumference of the circle; hence as the radii are equal, if we consider the pulley as a lever, the two arms are

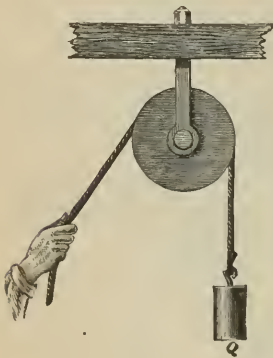

Fig. 20

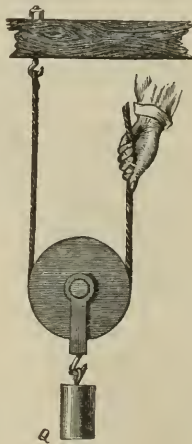

Fig. 21

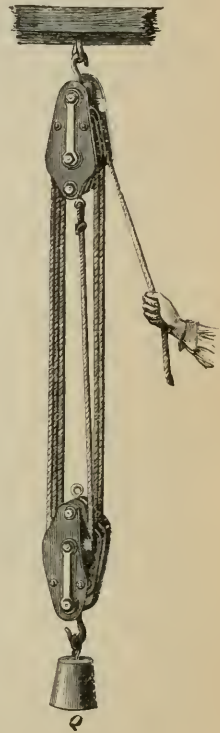

Fig. 22

equal, and equilibrium will prevail when the power and the resistance are equal. The fixed pulley affords thus no mechanical advantage, but is simply convenient in changing the direction of the application of a force.

In the case of the movable pulley one end of the rope is suspended to a fixed point in a beam, and the weight is attached to the hook on which the pulley acts. The tension of the rope is everywhere the same; one portion

of the weight is supported by the fixed part and the other by the power, and these are equal to each other, and are together equal to the weight, including the pulley itself; hence in this case $P = \frac{1}{2}Q$.

If several pulleys are joined together on a common axis in a special sheath, which is fixed, and a rope passes round all those, and also round a similar but movable combination of pulleys, such an arrangement, which is represented in fig. 22, is called a *block and tackle*.

If we consider the condition of the rope it will be found to have everywhere the same tension; the weight Q which is attached to the hook common to the whole system is supported by the six portions of the rope: hence each of these portions will sustain one-sixth of the weight; the force which is applied at the free end of the rope which passes over the upper pulley, and which determines the tension, will have the same value; that is to say, it will support one-sixth of the weight.

The relation between power and weight in a block and tackle is expressed by the equation $P = \frac{Q}{n}$, in which P is the power, Q the weight, and n the number of cords by which the weight is supported.

45. **The wheel and axle.**—The older form of this machine, fig. 23, is that of an axle, to which is rigidly fixed, concentric with it, a wheel of larger diameter. The power is applied tangentially on the wheel, and the resistance tangentially to the axle, as, for instance, in the treadmill and water-wheel. Sometimes, as in the case of the capstan, the power is applied to spokes fixed in the axle, which represent semi-diameters of the wheel; in other cases, as in the windlass, the handle is rigidly fixed to the axis.

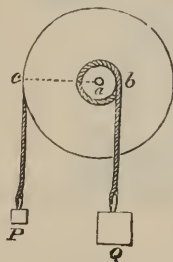

Fig. 23

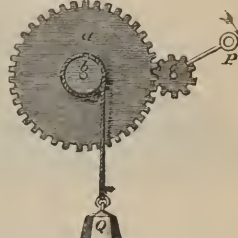

Fig. 24

In all its modifications we may regard the wheel and axle as an application of the lever, the arms of which are the radii of the wheel and axle respectively; and in all cases equilibrium exists where the power is to the weight or resistance as the radius of the axle is to the radius of the wheel. Thus in fig. 23, $P : Q = ab : ac$, or $P \times ac = Q \times ab$.

Frequent applications of wheels of different diameters are met with in which the motion of one wheel is transmitted to another, either by means of teeth fitting in each other on the circumference of the wheels, as in fig. 24, or by means of bands passing over the two wheels.

In fig. 24, which represents the essential parts of a crab winch, in order to raise the weight Q a power p must be applied at the circumference of the wheel such that $p = Q \frac{r}{R}$, in which r and R are the radii of the axle b and of the toothed wheel a respectively.

The rotation of the wheel a is effected by means of the smaller wheel c or *crab*, the teeth of which fit in those of a . But if this wheel c is to exert at its circumference a power p , the power P which is applied at the end of

the handle must be $P = \frac{r'}{R} Q$, in which r' is the radius of c , R' the length of a lever at the end of which P acts, and consequently

$$P = \frac{r r'}{R R'} Q.$$

The radius of the wheel c is to that of the wheel a as their respective circumferences ; and, as the teeth of each are of the same size, the circumferences will be as the number of teeth.

Trains of wheelwork are used, not only in raising great weights by the exertion of a small power, as in screwjacks, cranes, crab winches, &c., but also in clock and watch works, and in cases in which changes in velocity or in power, or even in direction, are required. Numerous examples will be met with in the various apparatus described in this work.

46. **Inclined plane.**—The properties and laws of the inclined plane may be conveniently demonstrated by means of the apparatus represented in

fig. 25. RS represents the section of a smooth piece of hard wood hinged at R ; by means of a screw it can be clamped at any angle x against the arch-shaped support, by which at the same time the angle can be measured ; a is a cylindrical roller, to the axis of which is attached a string passing over a pulley to a scale-pan P .

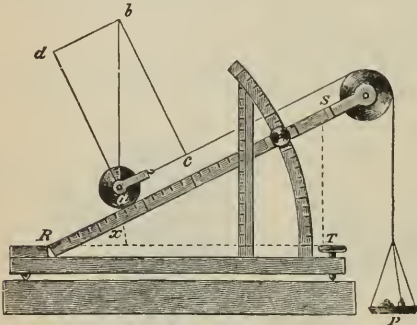

Fig. 25

It is thus easy to ascertain by direct experiments what weights must be placed in the

pan P in order to balance a roller of any given weight with the plane fixed at a given angle of inclination.

The line RS represents the *length*, ST the *height*, and RT the *base* of the inclined plane.

In ascertaining the theoretical conditions of equilibrium we have a useful application of the parallelogram of forces. Let the line ab , fig. 25, represent the force which the weight W of the cylinder exerts acting vertically downwards ; this may be decomposed into two others ; one ad , acting at right angles against the plane, and representing the *pressure* which the weight exerts against the plane, and which is counterbalanced by the reaction of the plane ; the other, ac , represents the component which tends to move the weight down the plane, and this component has to be held in equilibrium by the weight P , equal to it, and acting in the opposite direction.

It can be readily shown that the triangle abc is similar to the triangle SRT , and that the sides ac and ab are in the same proportion as the sides ST and SR . But the line ac represents the power, and the line ab the weight ; hence

$$ST : SR = P : W ;$$

that is, on an inclined plane, equilibrium obtains when the power is to the weight as the height of the inclined plane to its length.

Since the ratio $\frac{ST}{SR}$ is the sine of the angle x , we may also state the principle thus :

$$P = W \sin x.$$

The component da or bc , which represents the actual pressure against the plane, is equal to $W \cos x$; that is the pressure against the plane is to the weight as the base is to the length of the inclined plane.

In the above case it has been considered that the power acts parallel to the inclined plane. It may be applied so as to act horizontally. It will then

be seen from fig. 26 that the weight W may be decomposed into two forces, one of which, ab , acts at right angles to the plane, and the other, ac , parallel to the base. It is this latter which is to be kept in equilibrium by the power. From the similarity of the two triangles acb and STR , $ac : bc = ST : TR$; but bc is equal to W , and ac is equal to P ; hence the power which must be applied at b to hold the weight W in equilibrium is as the height of the inclined plane is to the base or as the tangent of the angle of inclination x ; that is, $P = W \tan x$. The pressure upon the plane in this case may be easily shown to be $ab = \frac{bc}{\cos x}$,

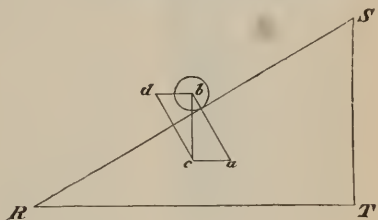

Fig. 26

that is $R = \frac{W}{\cos x}$, where R is the pressure upon the plane. This is sometimes called the *relative weight* on the plane.

If the force P which is to counterbalance W is not parallel to the plane, but forms an angle, E , with it, this force can be decomposed into one which is parallel to it, and one which is at right angles. Of these only the first is operative, and is equal to $P \cos E$.

In most cases of the use of the inclined plane, such as in moving carriages and waggons along roads, in raising casks into waggons or warehouses, the power is applied parallel to the inclined plane. An instance of a case in which a force acts parallel to the base is met with in the screw.

Owing to the unevenness of the surfaces in actual use, and the consequent *friction* when one body moves over another, the laws of equilibrium and of motion on an inclined plane undergo modification. Friction must be looked upon as a hindrance to be continually overcome, and must be deducted from the force required to keep a body from falling down an inclined plane, or must be added to it in the case in which a body is to be moved up the plane. (See art. 50.)

Thus if we place on the plane a block of some material, by gradually increasing the inclination it will begin to move at a certain angle, which will depend on the nature of the material ; this angle is the *limiting angle of resistance*, and its tangent is the *coefficient of friction* for that material.

This may serve as a rough illustration of a mode of determining this coefficient.

47. **The wedge.**—The ordinary form of the wedge is that of a three-sided prism of iron or steel, one of whose angles is very acute. Its most frequent use is in splitting stone, timber, &c. Fig. 27 represents in section the application of the wedge to this purpose. The side ab is the *back*, the vertex of the angle acb which the two faces ac and bc make with each other represents the *edge*, and the faces ac and bc the *sides* of the wedge. The power P is usually applied at right angles to the back; and we may look upon the cohesion between the fibres of the wood as representing the resistance to be overcome; as corresponding to what in other machines is the weight. Suppose this to act at right angles to the two faces of the wedge, and to be represented by lines fe and ge ; complete the parallelogram gef , then the diagonal he will represent the resultant of the reaction of the fibres tending to force the wedge out; the force which must be applied to hold this wedge in equilibrium must therefore be equal to eh . Now efh is similar to the triangle

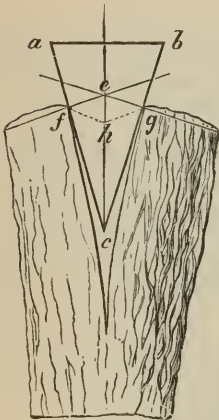

Fig. 27

acb , therefore $ab : ac = eh : ef$; but these lines represent the pressure applied at the back of the wedge, and the pressure on the face ac , hence if P represent the former and Q the latter, there is equilibrium when $P : Q = ab : ac$, that is, when the power is to the resistance in the same ratio as the back of the wedge bears to one of the sides. The relation between power and resistance is more favourable the sharper the edge, that is, the smaller the angle which the sides make with each other.

The action of all sharp cutting instruments, such as chisels, knives, scissors, &c., depends on the principle of the wedge. It is also applied when very heavy weights are to be raised through a short distance, as in launching ships, and in bracing columns and walls to the vertical.

48. **The screw.**—Let us suppose a piece of paper in the shape of a right-angled triangle aee' to be applied with its vertical side $ac'e'$ against a

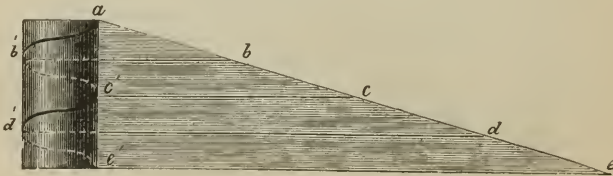

Fig. 28

cylinder, and parallel to the axis, and to be wrapped round the cylinder; the hypotenuse will describe a screw line or *helix* on the surface of the cylinder (fig. 28); the points $abcde$ will occupy the positions respectively $ab'c'd'e'$.

If the dimensions be so chosen that the base of the triangle, ac' , is equal to the circumference of the cylinder, then the hypotenuse abc becomes an inclined plane traced on the surface of the cylinder; the distance ac' being the height of the plane.

An ordinary screw consists of an elevation on a solid cylinder; this elevation may be either square, as in fig. 29, or acute; and such screws are called *square* or *sharp* screws accordingly.

When a corresponding groove is cut in the hollow cylinder or nut of the same diameter as the bolt, this gives rise to an internal or *companion* screw or *nut*, fig. 30.



Fig. 29



Fig. 30

The distance between any two threads of a screw measured parallel to the axis is called the *pitch*, and the angle acc' or aee' is called the *inclination* of the screw.

In practice, a raised screw is used with its companion in such a manner that the elevations of the one fit into, and coincide with, the depressions of the other. The screw is a modification of the inclined plane, and the conditions of equilibrium are those which obtain in the case of the plane. The resistance R , which is either a weight to be raised, or a pressure to be exerted, acts in the direction of the vertical, and the power acts parallel to the base; hence we have $P : R = h : b$, and the length of the base is the circumference of the cylinder; whence $P : R = h : 2\pi r$; r being the radius of the cylinder, and h the pitch of the screw.

The power is usually applied to the screw by means of a lever, as in the bookbinder's press, the copying press, &c., and the principle of the screw may be stated to be generally that the power of the screw is to the resistance in the same ratio as that of the pitch of the screw to the circumference of the circle through which the power acts.

49. **Friction.**—In the cases of the actions of machines which have hitherto been described, the resistances which are offered to motion have not been at all considered. The surfaces of bodies in contact are never perfectly smooth; even the smoothest present inequalities which can be detected neither by the touch nor by ordinary sight; hence when one body moves over the surface of another, the elevations of one sink into the depressions of the other, like the teeth of wheels, and thereby offer a certain resistance to motion; this is what is called *friction*. It must be regarded as a force which continually acts in opposition to actual or possible motion.

Friction is of two kinds: *sliding*, as when one body glides over another; this is least when the two surfaces in contact remain the same, as in the motion of an axle in its bearing; and *rolling* friction, which occurs when one body rolls over another, as in the case of an ordinary wheel. The latter is less than the former, for by the rolling the inequalities of one body are raised over those of the other. As rolling friction is considerably less than sliding friction, it is a great saving of power to convert the latter into the former; as is done in the case of the casters of chairs and other furniture, and also in that of friction wheels. This, however, is not always the case; thus a sledge experiences less friction on snow than a carriage, for in this case the wheels sink and friction on the sides results. On the other hand, it is sometimes

useful to change rolling into sliding friction, as when drags are placed on carriage-wheels.

Friction is directly proportional to the pressure of the two surfaces against each other. The ratio of the force which must act merely to overcome friction to the pressure is called the *coefficient of friction*.

Friction is independent of the extent of the surfaces in contact if the pressure is the same. Thus, suppose a board with a surface of a square decimetre resting on another board to be loaded with a weight of a kilogramme. If this load is distributed over a similar board of two square decimetres' surface, the total friction will be the same, while the friction per square centimetre is one-half; for the pressure on each square centimetre is one-half of what it was before. So, too, a rectangular stone experiences the same friction whether it is laid on the narrow or on the broad side. Friction is diminished by polishing and by smearing, but is increased by heat. It is greater as a body passes from the state of rest to that of motion than during motion, but seems independent of the velocity. The coefficient of friction depends on the nature of the substances in contact; similar bodies experience in general greater friction than dissimilar ones, for with the former the inequalities fit more into one another; thus for oak upon oak it is 0.418 when the fibres are parallel, and 0.293 when they cross; for beech upon beech it is 0.36. Greasy substances, which are not absorbed by the body, diminish friction, but increase it if they are absorbed. Thus moisture and oil increase, while tallow, soap, and graphite diminish, the friction of wooden surfaces. In the sliding friction of cast iron upon bronze the coefficient was found to be 0.25 without grease; with oil it was 0.17, fat 0.11, soap 0.03, and with a mixture of fat and graphite 0.002. The coefficient of rolling friction for cast-iron wheels on iron rails as in railways is about 0.004; for ordinary wheels on an ordinary road it is 0.04, hence a horse can draw ten times as great a load on rails as on an ordinary road, and this is indeed a main use of rail and tram ways. The coefficient of steel upon smooth ice has been determined by a skater holding in his hand a spring balance (87) attached to a cord by which he was drawn along by a second skater. At starting the spiral showed a pull of 5 to 6 kilos, but during the motion this varied between 1 and 2 kilos. As the weight of the skater was 62 kilos, the coefficient of friction during the motion was $\frac{1}{62}$ to $\frac{2}{62}$, or 1.6 to 3.2 per cent.

Without friction on the ground, neither man nor animals, neither ordinary carriages nor railway carriages, could move. Friction is necessary for the transmission of power from one wheel to another by means of bands or ropes; and without friction we could hold nothing in the hands.

50. **Resistance to motion in a fluid medium.**—A body in moving through any medium, such as air or water, experiences a certain resistance; for the moving body sets in motion those parts of the medium with which it is in contact, whereby it loses an equivalent amount of its own motion.

This resistance increases with the surface of the moving body; thus a soap-bubble or a snow-flake falls more slowly than does a drop of water of the same weight. It also increases with the density of the medium; in rarefied air, therefore, it is less than in air under the ordinary pressure; and in this again it is less than in water.

The influence of this resistance may be illustrated by means of the apparatus represented in fig. 31, which consists of two vanes, wv , fixed to a horizontal axis, xx , to which is also attached a bobbin s . The rotation of the vanes is effected by means of the falling of a weight attached to the string coiled round the bobbin. The vanes can be adjusted either at right angles or parallel to the axis. In the former position the vanes rotate rapidly when the weight is allowed to act; in the latter, however, where they press with their entire surface against the air, the resistance greatly lessens the rapidity of rotation.

The resistance increases with the velocity of the moving body, and for moderate velocities is proportional to the square; for supposing the velocity of a body made twice as great, it must displace twice as much matter, and must also impart to the displaced particles twice the velocity. For high velocities the resistance in a medium increases in a more rapid ratio than that of the square, for some of the medium is carried along with the moving body, and this by its friction against the other portions of the medium causes a loss of velocity.

It is this resistance which so greatly increases the difficulty and cost of attaining very high speeds in steam vessels, to which must be added the production of waves on the surface, and of eddy currents. Use is made, on the other hand, of this resistance in parachutes (fig. 186) and in the windvanes for diminishing the velocity of falling bodies (fig. 63), the principle of which is illustrated by the apparatus, fig. 31. Light bodies fall more slowly in air than heavy ones of the same surface for the moving force is smaller compared with the resistance. The resistance to a falling body may ultimately equal its weight; it then moves uniformly forward with the velocity which it has acquired. Thus, a raindrop falling from a height of 3000 feet should, when near the ground, have a velocity of nearly 440 feet per second, or that of a musket-shot; owing, however, to the resistance of the air, its actual velocity is probably not more than 30 feet in a second. On railways the resistance of the air is appreciable; with a carriage exposing a surface of 22 square feet, it amounts to 16 or 17 pounds when the speed of the train is 16 feet a second, or 11 miles an hour.

By observing the rate of diminution in the number of oscillations of a horizontal disc suspended by a thread when immersed in water, Meyer determined the frictional or internal resistance of water, and found that at 10° it was equal to 0.01567 gramme on a square centimetre; and for air it was about $\frac{1}{40}$ as much.

51. Uniformly accelerated rectilinear motion.—Let us suppose a body containing m units of mass to move from rest under the action of a force of F units; the body will move in the line of action of the force, and will acquire in each second an additional velocity f given by the equation

$$F = mf;$$

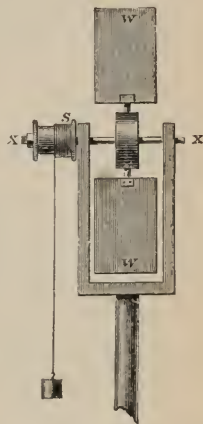

Fig. 31

consequently, if v is its velocity at the end of t seconds, we have

$$v = ft. \tag{1}$$

To determine the space it will describe in t seconds, we may reason as follows:—The velocity at the time t being ft , that at a time $t + \tau$, where τ is a small interval of time, will be $f(t + \tau)$. If the body moved uniformly during the time τ with the former velocity, it would describe a space s equal to $f\tau$; if with the latter velocity, a space s_1 , equal to $f(t + \tau)\tau$. Consequently,

$$s_1 : s :: t + \tau : t;$$

therefore, when τ is indefinitely small, the limiting values of s and s_1 are equal. Now, since the body's velocity is continually *increasing* during the time τ , the space actually described is greater than s and less than s_1 . But since the limiting values of s and s_1 are equal, the limiting value of the space described is the same as that of s or s_1 . In other words, if we suppose the whole time of the body's motion to be divided into any number of equal parts, if we determine the velocity of the body at the beginning of each of these parts, and if we ascertain the spaces described on the supposition that the body

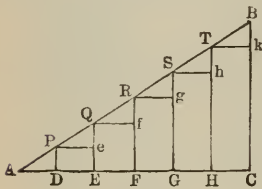

Fig. 32

moves uniformly during each portion of time, the limiting value of the sum of these spaces will be the space actually described by the body. Draw a line AC (fig. 32), and at A construct an angle CAB, whose tangent equals f ; divide AC into any number of equal parts in D, E, F,...and draw PD, QE, RF,...BC at right angles to AC; then since $PD = AD \times f$, $QE = AE \times f$, $RF = AF \times f$, $BC = AC \times f$, &c., PD will represent the velocity of the body at the end of the time represented by AD, and similarly QE, RF,...BC, will represent the velocity at the end of the times AE, AF,...AC. Complete the rectangles De, Ef, Fg... These rectangles represent the space described by the body, on the above supposition, during the second, third, fourth,...portions of the time. Consequently, the space actually described during the time AC is the limit of the sum of the rectangles; the limit being continually approached as the number of parts into which AC is divided is continually increased. But this limit is the area of the triangle ABC; that is $\frac{1}{2}AC \times CB$ or $\frac{1}{2}AC \times AC \times f$. Therefore, if AC represents the time t during which the body describes a space s , we have

$$s = \frac{1}{2} ft^2. \tag{2}$$

Since this equation can be written

$$2fs = f^2 t^2$$

we find, on comparison with equation (1), that

$$v^2 = 2fs. \tag{3}$$

To illustrate these equations, let us suppose the accelerative effect of the force to be 6; that is to say that, in virtue of the action of the force, the body acquires in each successive second an additional velocity of 6 feet per second; and let it be asked what, on the supposition of the body moving from rest,

will be the velocity acquired, and the space described, at the end of 12 seconds; equations 1 and 2 enable us to answer that at that instant it will be moving at the rate of 72 feet per second, and will have described 432 feet.

The following important result follows from equation (2). At the end of the first, second, third, fourth, &c., second of the motion, the body will have described $\frac{1}{2}f$, $\frac{1}{2}f \times 4$, $\frac{1}{2}f \times 9$, $\frac{1}{2}f \times 16$, &c., feet; and consequently *during* the first, second, third, fourth, &c., second of the motion will have described $\frac{1}{2}f$, $\frac{1}{2}f \times 3$, $\frac{1}{2}f \times 5$, $\frac{1}{2}f \times 7$, &c., feet, namely spaces in arithmetical progression.

The results of the above article can be stated in the form of laws which apply to the condition of a body moving from a state of rest under the action of a constant force:—

I. *The velocities are proportional to the times during which the motion has lasted.*

II. *The spaces described are proportional to the squares of the times employed in their description.*

III. *The spaces described are proportional to the squares of the velocities acquired during their description.*

IV. *The spaces described in equal successive periods of time increase by a constant quantity.*

Instead of supposing the body to begin to move from a state of rest, we may suppose it to have an initial velocity V , in the direction of the force. In this case equations 1, 2, and 3 can be easily shown to take the following forms, respectively:—

$$\begin{aligned}v &= V + ft, \\s &= Vt + \frac{1}{2}ft^2, \\v^2 &= V^2 + 2fs.\end{aligned}$$

If the body moves in a direction opposite to that of the force, f must be reckoned negative.

The most important exemplification of the laws stated in the present article is in the case of a body falling freely *in vacuo*. Here the force causing the acceleration is that of gravity, and the acceleration produced is denoted by the letter g : it has already been stated (32) that the numerical value of g is 32.1912 at London, when the unit of time is a second and the unit of length a foot. Adopting the metre as unit of length, the value of g at London is 9.8117.

52. **Motion on an inclined plane.**—Referring to (46), suppose the force P not to act; then the mass M of the roller is acted on by an unbalanced force $Mg \sin x$, in the direction SR ; consequently the acceleration down the plane is $g \sin x$, and the motion becomes a particular case of that discussed in the last article. If it begins to move from rest, it will at the end of t seconds acquire a velocity v given by the equation

$$v = gt \sin x,$$

and will describe a length s of the plane given by the equation

$$s = \frac{1}{2}gt^2 \sin x.$$

Also, if v is the velocity acquired while describing s feet of the plane,

$$v^2 = 2gs \sin x.$$

Hence (fig. 25), if a body slides down the plane from S to R, the velocity which it acquires at R is equal to $\sqrt{2g \cdot RS \sin x}$, or $\sqrt{2g \cdot ST}$; that is to say, the velocity which the body has at R does not depend on the angle x , but only on the perpendicular height ST. The same would be true if for RS we substituted any smooth curve; and hence we may state generally that when a body moves along any smooth path under the action of gravity, the change of velocity it experiences in moving from one point to another is that due to the *vertical* height of the former point above the latter.

53. **Motion of projectiles.**—The equations given in the above article apply to the case of a body thrown vertically upwards or downwards with a certain initial velocity. We will now consider the case of a heavy body thrown in a horizontal direction. Let a , fig. 33, be such a body thrown with an initial velocity of v feet in a second, and let the line ab represent the space described in any interval; then at the end of the 2nd, 3rd, 4th . . . equal interval, the body, in virtue of its inertia, will have reached the points $c, d, e, \&c.$ But during all this time the body is under the influence of gravity, which, if it alone acted, would cause the body to fall through the distances represented on the vertical line; these are determined by the successive values of $\frac{1}{2}gt^2$, which is the formula for the space described by a freely falling body (52). The effect of the combination of the two motions is that at the end of the first interval, &c., the body will be at $b',$ at the end of the second interval at $c',$ of the third at $d',$ &c., the spaces $bb' cc' dd' . . .$ being proportional to the squares of $ab, ac, ad,$ respectively, and the line joining these points represents the path of the body. By taking the intervals of time sufficiently small we get a regularly curved line of the form known as the *parabola*.

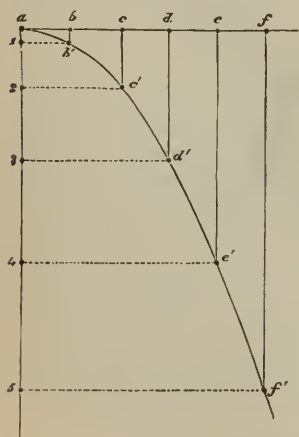

Fig. 33

sufficiently small we get a regularly curved line of the form known as the *parabola*.

In order to demonstrate motion with horizontal and inclined direction the apparatus represented in fig. 34 may be made use of. It consists of a bottle from which a steady stream of water issues through an india-rubber tube terminating in a jet. This can be discharged in front of a slate or blackboard on which the path of the curve in each case can be chalked.

If the direction in which the body is thrown makes an angle of a with the horizon (fig. 35), then after t seconds it would have travelled a distance $ab = vt$, where v is the original velocity; during this time, however, it will have fallen through a distance $bc = \frac{1}{2}gt^2$; the height which it will have actually reached is $= bd - bc = vt \sin a - \frac{1}{2}gt^2$; and the horizontal distance will be $ad = ab \cos a = vt \cos a$. The *range* of the body, or the greatest distance through which it is thrown, will be reached when the height is again = 0; that is, when $vt \sin a - \frac{1}{2}gt^2 = 0$, from which $t = \frac{2v \sin a}{g}$. Introducing this value of t into the equation for the distance, d , we have

$$d = \frac{2v^2 \sin a \cos a}{g}, \text{ which by a trigonometrical transformation } = \frac{v^2 \sin 2a}{g}$$

The greatest height is attained in half the time of flight, or when $t = \frac{v \sin a}{g}$

from which we get

$$h = \frac{v^2 \sin^2 a}{2g}$$

It follows from the formula that the *height* is greatest when $\sin a$ is greatest, which is the case when it = 90, or when the body is thrown vertically upwards; the *range* is greatest where $\sin 2a$ is a maximum, that is, when $2a = 90^\circ$ or $a = 45^\circ$.

In these formulæ it has been assumed that the air offers no resistance. This is, however, far from the case, and in practice, particularly if the velocity of projection is very great, the path differs from that of a parabola. Fig. 35 approximately represents the path, allowing for the resistance of the air. The divergence from the true theoretical path is affected by the fact that in the modern rifled arms the projectiles are not spherical in shape; and also because, along with their

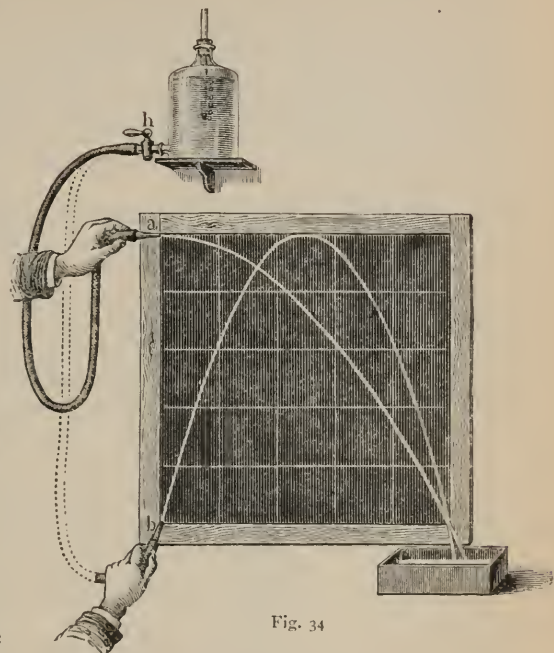

Fig. 34

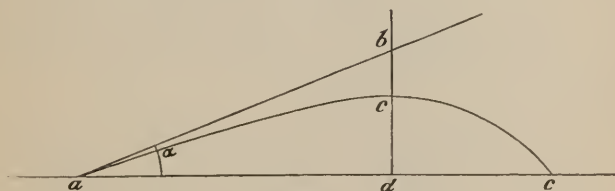

Fig. 35

motion of translation, they have, in consequence of the rifling, a rotatory motion above their axis.

54. **Composition of velocities.**—The principle for the composition of velocities is the same as that for the composition of forces: this follows evidently from the fact that forces are measured by the momentum they communicate, and are therefore to one another in the same ratio as the velocities they communicate to the *same* body. Thus (fig. 10, art. 36), if the point has

at any instant a velocity AB in the direction AP , and there is communicated to it a velocity AC in the direction AQ , it will move in the direction AR with a velocity represented by AD . And, conversely, the velocity of a body represented by AD can be resolved into two component velocities AB and AC . This suggests the method of determining the motion of a body when acted on by a force in a direction transverse to the direction of its velocity; namely, suppose the time to be divided into a great number of intervals, and suppose the velocity actually communicated by the force to be communicated at once; then by the composition of velocities we can determine the motion during each interval, and therefore during the whole time; the actual motion is the limit to which the motion, thus determined, approaches when the number of intervals is increased.

55. **Motion in a circle. Centrifugal force.**—When a body is once in motion, unless it is acted upon by some force, it will move uniformly forward in a straight line with unchanged velocity (29). If, therefore, a body moves uniformly in any other path than a straight line—in a circle, for instance—this must be because some force is constantly at work which continuously deviates it from this straight line.

We have already seen an example of this in the case of the motion of projectiles (53), and will now consider it in the case of central motion or motion in a circle, of which we have an example in the motion of the celestial bodies, or in the motion of a *sling*.

In the latter case, if the string is cut, the stone, ceasing to be acted upon by the tension of the string, will move in a straight line with the velocity which it already possesses—that is, in the direction of the tangent to the curve at the point where the stone was when the string was cut. The tension of the string, the effect of which is to pull the stone towards the centre of the circle and to cause the stone to move in its circular path, is called the *centripetal* or *central* force; the reaction of the stone upon the string, which is equal and opposite to this force, is called the *centrifugal* force. The amount of the forces may be arrived at as follows:—

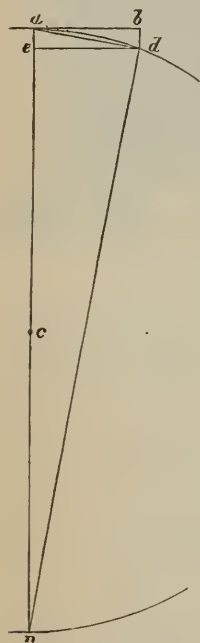

Fig. 36

Let us suppose a body moving in a circle with given uniform velocity to be at the point a (fig. 36); then, had it not been acted on by a force in the direction ac , it would, in a small succeeding interval of time t , have continued to move in the direction of the tangent at a , and have passed through a distance which we will represent by ab . In consequence, however, of this force, it has not followed this direction, but has arrived at the point d on the curve; hence the force has made it traverse the distance $bd = ae$ in this interval. If f is the acceleration with which the body is drawn towards the centre, $ae = \frac{1}{2}ft^2$, and if ad is very small, it may be taken as equal to ab or vt , where v is the velocity of the moving body. Now if an is the diameter of the circle, the triangle adn is inscribed in a

semicircle and is right-angled, whence $ad^2 = ae \times an = ae \times 2r$. Substituting their values for ad and ae in this equation, we find that $v^2 t^2 = \frac{1}{2} ft^2 \times 2r$, from which $f = \frac{v^2}{r}$, hence $F = mf = \frac{mv^2}{r}$; that is, in order that a body with a certain velocity may move in a circle, it must be drawn to the centre by a force which is directly as the square of the velocity with which the body moves, and inversely as the radius of the circle. To keep the body of mass m in a circle, an attraction towards the centre is needed, which is constantly equal to $\frac{mv^2}{r}$, and this attraction is also constantly neutralised by the centrifugal force.

The above expression may be put in a form which is sometimes more convenient. If T is the time in seconds required to traverse the circumference $2\pi r$ with the velocity v , then $v^2 = \frac{4\pi^2 r^2}{T^2}$, from which $F = \frac{4m\pi^2 r}{T^2}$.

If a rigid body rotates about a fixed axis, all parts of the body describe circles of various diameters. The velocity of the motion of individual particles increases with the distance from the axis of rotation. By *angular velocity* is understood the velocity of a point at unit distance from the axis of rotation. If this is denoted by ω , the velocity v of a point at a distance from the axis is ωr , from which $\omega = \frac{v}{r} = \frac{2\pi}{T}$ and $F = mr\omega^2$.

The existence of centrifugal force may be demonstrated by means of numerous instructive experiments, such as the *centrifugal railway*. If a small can of water hung by the handle to a string be rapidly rotated in a vertical circle, no water will fall out, for, at a suitable velocity, the liquid will press against the bottom of the vessel with a force at right angles to the circle and greater than its own weight.

Centrifugal force has been used in chemical laboratories to separate crystals from the mother-liquors, and also to promote the deposition of fine precipitates which under ordinary circumstances settle very slowly; it is also applied industrially in sugar factories to purify sugar from syrup, in dyeworks to dry yarn and cloth rapidly, and in laundries.

56. Motion of a simple pendulum.—By a simple pendulum is meant a heavy particle suspended by a fine weightless thread from a fixed point, about which it oscillates without friction. We cannot realise such a pendulum, but we can approximate to it for experimental purposes by using a small leaden bullet attached to a fine wire—the friction at the point of suspension being reduced to a minimum. Let the bullet be drawn aside to the point A (fig. 37), and let go so that it may oscillate in a vertical plane. We proceed to consider the velocity of the bullet and the force acting upon it at different parts of its path. We notice first that the motion is symmetrical about the vertical. Starting from rest at A the bullet moves with gradually increasing velocity to C, then slows down until it comes to rest at B. Then it returns through C to A, passing through the same series of changes in the opposite direction. Suppose the bullet to be at P, descending the curve. The forces acting upon it are its weight, mg , acting vertically downwards, and the tension of the string T acting along PO. The resultant is a force, F , at

right angles to the string, and is the resolved part of the weight acting tangentially to the circle. If F denotes this resolved part, $F = mg \sin \theta$. But since the sine of an angle when the angle is small is directly proportional to the arc which it subtends, it follows that the force acting on the bullet is proportional to its displacement from the vertical. As the bullet oscillates, the resultant of the forces acting upon it is a maximum at A and B and is zero at C . The velocity of the bullet may easily be determined. Complete the circle ABC (see fig. 38), join P to D , and draw the horizontal lines AMB , PNP' . Then

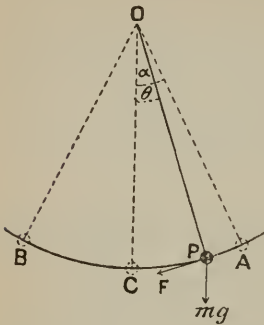

Fig. 37

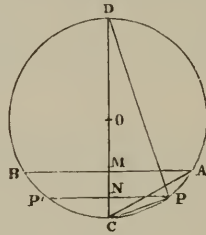

Fig. 38

since the velocity acquired in falling from A to P is that due to MN , the vertical height of A above P , we shall have, if v denotes the velocity of the bullet,

$$v^2 = 2g \cdot MN.$$

But, by a well-known property of the circle,

$$a^2 = 2l \times MC \quad \text{and} \quad s^2 = 2l \times NC,$$

where a and s are the chords CA and CP respectively, and $l = OC$.

$$\therefore a^2 - s^2 = 2l \times MN, \quad \text{and} \quad v^2 = \frac{g}{l} (a^2 - s^2).$$

Now, v has equal values for a given value of s whether positive or negative, and for any value of s there are two values of v , one positive and one negative. That is to say, since $CP' = CP$, the bullet will have the same velocity at P' that it has at P , and at any point it will have the same velocity whether it is going up the curve or down the curve. Of course it is included in this statement that if the bullet begins to move from A it will just ascend to B on the other side of C , such that A and B are on the same horizontal line. The velocity is a maximum when $s = 0$, *i.e.* at C , its value there being $V = a \sqrt{\frac{g}{l}}$.

The energy of the bullet (64) is the same at all parts of its path. At A and B it is entirely potential; at C it is entirely kinetic. At other points it is partly potential and partly kinetic.

The cause of motion is gravity. The pendulum would not oscillate but for the attraction between the earth and the bullet. If this were the only agency in operation the oscillations would go on with undiminished amplitude for ever. But the friction at the point of support and that of the air are constantly acting to oppose the motion, and so the bullet passing the point C from A does not quite mount up as high as B ; thus the bullet is gradually brought to rest.

The *period* of the pendulum is the time of a complete vibration, *i.e.* the

time required for the bob to pass from A to B and back again. It is proved in works on dynamics that the period $T = 2\pi\sqrt{\frac{l}{g}}$. The *amplitude* of the oscillation is the distance CA or CB, *i.e.* the greatest distance of the oscillating point from its mean position. A *seconds pendulum* is one which moves from A to B or from B to A in one second. The *period* of a seconds pendulum is two seconds. The period of oscillation is independent of the amplitude provided the latter be small, not exceeding five degrees. This property is spoken of as the *isochronism* of the pendulum, and the oscillations are said to be isochronous.

We see from the above that the period or time of oscillation of a pendulum is directly proportional to the square root of its length and inversely proportional to the acceleration of gravity.

As an example of the use of the formula we may take the following:—It has been found that 39·13983 inches is the length of a seconds pendulum at Greenwich; the formula at once leads to an accurate determination of the acceleration of gravity at Greenwich; for, using feet and seconds as our units, we have $l = 2$, $r = 3\cdot26165$, and π stands for the known number 3·14159; therefore the formula gives us

$$g = (3\cdot14159)^2 \times 3\cdot26165 = 32\cdot1912.$$

This is the value employed in (32).

Other examples will be met with in the Appendix.

57. **Simple harmonic motion. Circle of reference.**—If the pendulum is long and the arc of vibration small, the bullet, regarded as a particle, moves to and fro in a straight line. Let AB be the straight line. The velocity of the particle is zero at A and B, and a maximum, *viz.*

$$a \sqrt{\frac{g}{l}} \text{ at C; or since } T, \text{ the period,} = 2\pi \sqrt{\frac{l}{g}},$$

the maximum velocity is $\frac{2\pi a}{T}$, where a = the distance, AC, or amplitude of vibration.

On BA describe a circle. A particle moving round the circle with a certain uniform velocity will make a complete circuit in the time (T) which the oscillating particle requires to go from A to B and back again. This

velocity is clearly $\frac{2\pi a}{T}$, since $2\pi a$ is the circumference of the circle, and it is not difficult to prove that the velocity at any point, P, in the circular path resolved parallel to AB, is equal to the velocity of the oscillating particle when it has reached M, the foot of the perpendicular drawn from P on AB. Thus the revolving and the oscillating particles, if they start together, are throughout the period in such relative positions as P to M, Q to N, &c.

The motion in AB is called *simple harmonic motion*, and in regard to it the circle ADBD' is called the *circle of reference*. Simple harmonic motion is characterised by the condition that the acceleration is proportional to the displacement of the vibrating particle from its mean position.

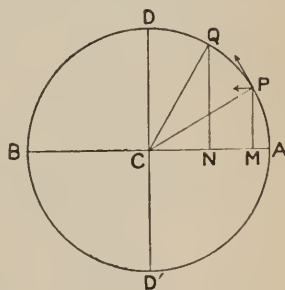

Fig. 39

The *phase* of vibration is the distance of the moving point, measured either in angle or in time from some definite point on its path, say from A. For instance, if the angle ACP is 30° , the phase of P or M is 30° , or $\frac{T}{12}$, since the time required to go from A to P is $\frac{T}{12}$. A and B are in opposite phases, and C is a quarter of a period, or 90° , before A or behind B.

58. **Composition of two simple harmonic motions at right angles to each other.**—We will first take the case in which the periods and also the amplitudes are equal to each other.

Let ADB be the circle of reference, and let each quadrant be divided into four equal parts. If T is the period of a particle oscillating in AB, its positions, supposing it to start from A, will be in the times $\frac{T}{16}, 2\frac{T}{16}, 3\frac{T}{16}, \&c.$, $p_1, p_2, p_3, \&c.$ respectively. If another particle starts at D and has simple

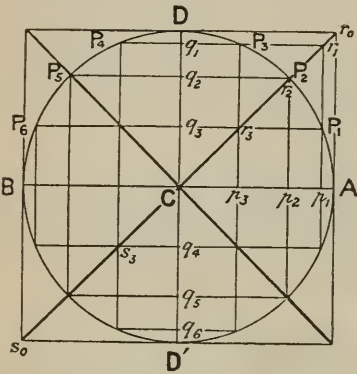

Fig. 40

harmonic motion along DD' , and the period is the same for the two rectangular motions, it is clear that the particles at the same moment will have the same velocity—they will meet at C, and when one reaches B the other will reach D' , and so on. The two particles are in the same phase. If we suppose a single point to have simultaneously two simple harmonic motions in rectangular directions, the path traced out by the point will depend upon the difference of phase in the two directions. If the phases are the same the resultant path will be a straight line equally inclined to the two

component directions. For suppose the particle to be at C and to move simultaneously towards A and towards D, it is clear that in the time $\frac{T}{16}$ it will be at r_3 , having traversed the line Cr_3 , in the time $2\frac{T}{16}$ it will be at P_2 , and so on. In the period T it will trace the line r_0s_0 twice over; in other words, it will have simple harmonic motion along s_0r_0 , its amplitude being Cr_0 and its period T.

If the two simple harmonic motions, instead of being in the same phase, differ in phase by a half period (or by 180°), the result of compounding them will again be a straight line, but it will be at right angles to r_0s_0 .

Suppose that the vibrating particle, considered as moving along AB, is at A (fig. 41), and, considered as moving along DD' is at q_2 , descending. Its actual position is X; after an interval $\frac{T}{16}$ it will be at P, after $2\frac{T}{16}$ at p_2 , and so on; and it is easy to see that the path traced out will be the ellipse shown in the figure. The difference of phase is one-eighth of a period, or one of the vibrations is 45° behind the other. If the phase difference

is 90° , or a quarter period, the ellipse will coincide with the circle of reference.

These results may be illustrated by a pendulum consisting of a bullet attached to a long string. Set the pendulum in vibration in a definite plane, and as the bullet passes its mean position give it a blow in a direction at right angles to that in which it is moving. The blow must be of such strength as will give the bullet a velocity equal to that which it has, but in a direction at right angles to the latter. The pendulum will now vibrate in a plane equally inclined to the two rectangular directions, and it will be seen that its amplitude is greater than before.

If the experiment is repeated in such a way that the blow (of the same force as before) be given to the bullet at the end, instead of in the middle, of its swing, the bullet will acquire a circular motion, and we shall have what is called a *conical pendulum*, since the string of the pendulum traces out a cone. In this case

the motions in rectangular directions differ in phase by a quarter period.

We may make the difference in phase anything we like by suitably choosing the point in the path of the vibrating pendulum at which the rectangular blow is delivered.

If the amplitudes of the vibrating points are not equal, the resulting curve will be an ellipse; it will be a straight line if the phase difference is $\frac{\pi}{2}$, and in

every other case an ellipse. This may be easily verified by trial either geometrically, or experimentally by the pendulum as above. The geometrical construction in this case, as in others in which the periodic times are different, is best effected by the use of two circles of reference. We proceed to give an example of the use of two such circles.

Let XcY , $X'qY'$ (fig. 42) be the circles of reference of two rectangular simple harmonic motions, one along XY , the other along $X'Y'$, and let the periods be as 3 : 2; that is, the oscillating point moves through $\frac{1}{2}$ th of the circumference of XcY while it is moving through $\frac{1}{3}$ th of the circumference of $X'qY'$. Divide the circumferences of the circles respectively into 12 and 8 parts, and draw horizontal and vertical lines through the points of division, as in the figure. The form of

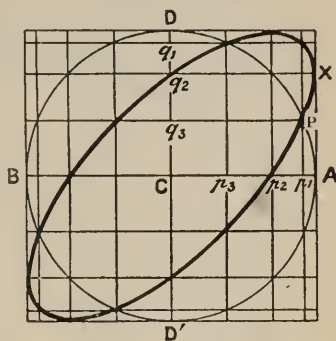

Fig. 41

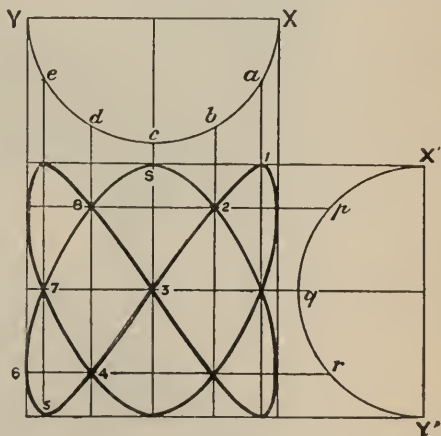

Fig. 42

the curve obtained by compounding the vibrations will depend upon the difference of phase. We will suppose that the point a in the one circle corresponds to X' in the other, b to p , c to q , &c. Then marking the intersections of the corresponding vertical and horizontal lines we get the points 1, 2, 3, &c. By joining these points the curve shown is obtained.

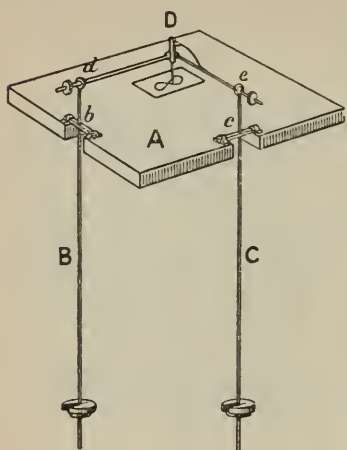

Fig. 43

upper ends to a vertical pencil or pen. If either pendulum is at rest and the other is set in vibration, the pencil traces a nearly straight line. If both

In chapter vi. of Book V. we shall see how beautifully these curves may be illustrated by means of tuning forks provided with mirrors at the ends of their prongs.

We may, however, by various mechanical contrivances obtain very close approximations to the theoretical figures. Tisley's Compound Pendulum apparatus or Harmonograph is one of the best of these. It consists of two pendulums (fig. 43) with adjustable sliding weights vibrating about knife edges in planes at right angles to each other. Light rods connect their

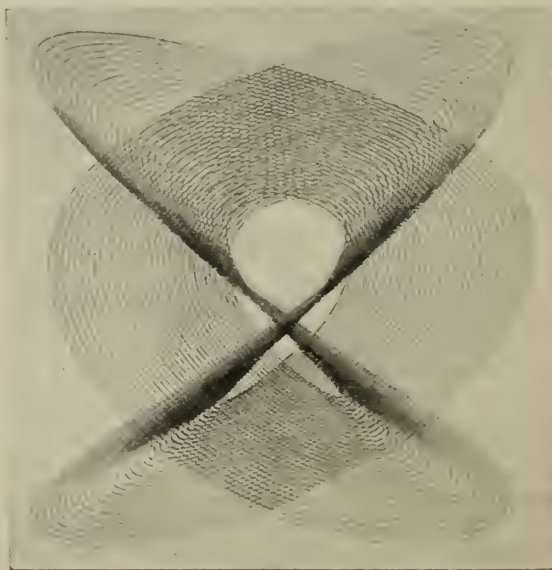

Fig. 44

pendulums are vibrating the pencil point traces a curve which is the result of compounding the curves produced by the separate vibrations. The relative

periods are varied by altering the positions of the sliding weights. Very beautiful figures may be obtained in this way.

An example is given in fig. 44. The pendulums are adjusted so that their periods are as 2 : 3 ; owing to the gradual diminution of the amplitudes of vibration, the point of the pen does not go over the same line a second time, but traces out a new curve in each period until it is stopped.

59. **Composition of simple harmonic motion with uniform motion in a direction at right angles to it.**—Let a point be moving in simple harmonic motion along DCD' (fig. 45), and suppose the line DCD' to move at right angles to

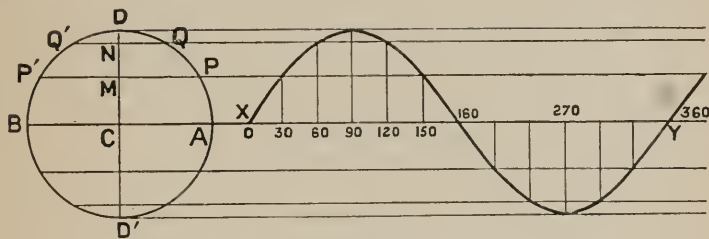

Fig. 45

itself with uniform velocity such that the distance XY is traversed in the periodic time T. Draw the circle of reference and divide the period and the circumference of the circle into any convenient number of equal parts, say 12. Divide XY also into 12 equal parts. Let the time be reckoned from the moment the oscillating point is moving upwards through C. Then in a time $\frac{T}{12}$ the oscillating point is at M, the corresponding point on the circle of reference being P, the revolving radius CP having swept out at an angle of 30° ; in $\frac{T}{12}$ the point is at N, and the angle swept out is 60° . In $\frac{T}{4}$ or $\frac{T}{4}$, the angle is 90° and so on ; thus we may conveniently divide the distance XY into 360° . Through M, N, D, &c., draw lines parallel to XY, and at the points 30, 60, 90, &c., erect perpendiculars equal respectively to CM, CN, CD, &c., and join the ends of the lines so drawn. The curve so obtained is called a sine curve, because any ordinate to the curve—e.g. that at 30, which is equal to CM—is proportional to the sine of the angle PCA or 30° . The equation of the curve is $y = a \sin \theta$, where a is the amplitude, y any ordinate of the curve, and θ the distance from X. Since $\theta = \frac{2\pi}{T} \times t, = nt$, where T is the period and t the time measured from X, we have $y = a \sin nt$.

A sine curve thus represents graphically simple harmonic motion, and we see from it at a glance the displacement corresponding to any phase of the motion.

Two or more harmonic vibrations in the same straight line, of any periods or amplitudes, may be compounded by the aid of their sine curves. All that is necessary for this purpose is to draw the curves corresponding to the separate vibrations with the necessary phase differences, and draw ordinates from point to point equal to the algebraic sum of the ordinates of the separate curves, above or below the mean line as the sum is positive or

negative. By joining together the extremities we obtain the resultant curve. The actual form of this curve will depend upon the difference of phase at any particular epoch.

60. **Work : meaning of the term.**—It has been pointed out (22, 29) that a moving body has no power of itself to change either the direction or the speed of its motion, and that, if any such change takes place, it is a proof that the body is acted upon by some external force. But although change of motion thus always implies the action of force, forces are often exerted without causing any change in the motion of the bodies on which they act. For instance, when a ship is sailing at a uniform speed, the force exerted on it by the wind causes no change in its motion, but simply prevents such a change being produced by the resistance of the water ; or, when a railway-train is running with uniform velocity, the force of the engine does not change, but only maintains its motion in opposition to the forces, such as friction and the resistance of the air, which tend to destroy it.

These two classes of cases—namely, first, those in which forces cause a change of motion ; and, secondly, those in which they prevent, wholly or in part, such a change being produced by other forces—include all the effects to which the action of forces can give rise. When acting in either of these ways, a force is said to *do work* : an expression which is used scientifically in a sense somewhat more precise than, but closely accordant with, that in which it is used in common language. A little reflection will make it evident that, in all cases in which we are accustomed to speak of work being done—whether by men, horse-power, or steam-power, and however various the products may be in different cases—the physical part of the process consists solely in producing or changing motion, or in keeping up motion in opposition to resistance, or in a combination of these actions. The reader will easily convince himself of this by calling to mind what the definite actions are which constitute the work done by (say) a navvy, a joiner, a mechanic, a weaver ; that done by a horse, whether employed in drawing a vehicle or in turning a gin ; or that of a steam-engine, whether it be used to draw a railway-train or to drive machinery. In all cases the work done is reducible, from a mechanical point of view, to the elements that have been mentioned, although it may be performed on different materials, with different tools, and with different degrees of skill.

It is, moreover, easy to see that any possible change or motion may be represented as a gain by the moving body of an additional (positive or negative) velocity either in the direction of its previous motion, or at right angles to it ; but a body which gains velocity is (30) said to be *accelerated*. Hence, what has been said above may be summed up as follows :—*When a force produces acceleration or when it maintains motion unchanged in opposition to resistance, it is said to do WORK.*

61. **Measure of work.**—In considering how work is to be measured, or how the relation between different quantities of work is to be expressed numerically, we have, in accordance with the above, to consider, first, *work of acceleration* ; and, secondly, *work against resistance*. But in order to make the evaluation of the two kinds of work consistent, we must bear in mind that one and the same exertion of force will result in work of either kind according to the conditions under which it takes place : thus, the force

of gravity acting on a weight let fall from the hand causes it to move with a continually accelerated velocity until it strikes the ground ; but if the same weight, instead of being allowed to fall freely through the air, be hung to a cord passing round a cylinder by means of which various degrees of friction can be applied to hinder its descent, it can be made to fall with a very small and practically uniform velocity. Hence, speaking broadly, it may be said that, in the former case, the work done by gravity upon the weight is work of acceleration only, while in the latter case it is work against resistance (friction) only. But it is very important to note that an essential condition, without which a force, however great, cannot do work either of one kind or the other, is that the thing acted on by it shall *move* while the force continues to act. This is obvious, for if no motion takes place it clearly cannot be either accelerated or maintained against resistance. The motion of the body on which a force acts being thus necessarily involved in our notion of work being done by the force, it naturally follows that, in estimating how much work is done, we should consider how much—that is to say, how far—the body moves while the force acts upon it. This agrees with the mode of estimating quantities of work in common life, as will be evident if we consider a very simple case—for instance, that of a labourer employed to carry bricks up to a scaffold : in such a case a double number of bricks carried would represent a double quantity of work done, but so also would a double height of the scaffold, for whatever amount of work is done in raising a certain number to a height of twenty feet, the same amount must be done again to raise them another twenty feet, or the amount of work done in raising the bricks forty feet is twice as great as that done when they are raised only twenty feet. It is also to be noted that no direct reference to *time* enters into the conception of a quantity of work : if we want to know how much work a labourer has done, we do not ask how long he has been at work, but what he has done—for instance, how many bricks he has carried, and to what height ; and our estimate of the total amount of work is the same whether the man has spent hours or days in doing it.

The foregoing relations between force and work may be put into definite mathematical language as follows :—If the point of application of a force moves in a straight line, and if the part of the force resolved along this line acts in the direction of the motion, the product of that component and the length of the line is the work done by the force. If the component acts in the opposite direction to the motion, the component may be considered as a resistance, and the product is work done against the resistance. Thus, in (46), if we suppose a to move up the plane from R to S, the work done by P is $P \times RS$: the work done against the resistance W is $W \sin x \times RS$. It will be observed that if the forces are in equilibrium during the motion, so that the velocity of a is uniform, P equals $W \sin x$, and consequently the work done by the power equals that done against the resistance. Also, since $RS \sin x$ equals ST, the work done against the resistance equals $W \times ST$. In other words, to raise W from R to S requires the same amount of work as to raise it from T to S.

If, however, the forces are not in equilibrium, the motion of a will not be uniform, but accelerated ; the work done upon it will nevertheless still be

represented by the product of the resultant force resolved along the direction of motion into the distance through which it moves.

In order to ascertain the relation between the amount of work done and the change produced by it in the velocity of the moving mass, we must recall one or two elementary mechanical principles. Let F be the resultant force resolved along the direction of motion, and S the distance through which its point of application moves : then, according to what has been said, the work done by the force = FS . Further, it has been pointed out (31) that a constant force is measured by the momentum produced by it in a unit of time : hence, if T is the time during which the force acts, V the velocity of the mass M at the beginning of this period, and V_1 the velocity at the end, the momentum produced during the time T is $MV_1 - MV$, and consequently the momentum produced in a unit of time, or, in other words, the measure of the force, is

$$F = \frac{M(V_1 - V)}{T}.$$

The distance S through which the mass M moves while its velocity changes from the value V to the value V_1 is the same as if it had moved during the whole period T with a velocity equal to the average value of the varying velocity which it actually possesses. But a constant force acting upon a constant mass causes its velocity to change at a uniform rate ; hence, in the present case, the average velocity is simply the arithmetical mean of the actual and final velocities :

$$S = \frac{1}{2}(V_1 + V)T.$$

Combining this with the last equation, we get as the expression for the work done by the force F :

$$FS = \frac{1}{2}M(V_1^2 - V^2) ;$$

or, in words, *when a constant force acts on a mass so as to change its velocity, the work done by the force is equal to half the product of the mass into the change of the square of the velocity.*

62. Unit of work. Power.—For strictly scientific purposes a unit of work is taken to be the work done by a unit of force when its point of application moves through the unit distance in the direction of its action ; but, as a convenient and sufficiently accurate standard for practical purposes, the quantity of work which is done in lifting 1 pound through the height of 1 foot is commonly adopted as the unit, and this quantity of work is spoken of as one ‘foot-pound.’ It is, however, important to observe that the foot-pound is not perfectly invariable, since the weight of a pound, and therefore the work done in lifting it through a given height, differs at different places, being a little greater near the Poles than near the Equator.

On the metric system the *kilogrammetre* is the unit ; it is the work done when a weight of a kilogramme is raised through a height of a metre. This is equal to 7·23 foot-pounds, and one foot-pound = ·1383 of a kilogrammetre.

In estimating the usefulness of any motor it becomes necessary to know the time required by it for doing a given amount of work. The amount of work per second is the *power* of the motor. The unit of power is the

power required to do a unit of work in a unit of time. For measuring the power of engines the unit used is the *horse-power*, which represents a rate of work of 33,000 foot-pounds per minute.

It is to be observed that in every case the unit is of the same denomination as the thing or quantity measured. The unit of length must be a length; the unit of value must be a definite quantity of some valuable commodity. The numbers, to determine which is one of the objects of physical research, are to be considered as abstract numbers, representing how many times the unit is taken.

63. **Systems of units.**—The units of mass, length, and time are said to be *fundamental* units, as all other units, such as those of area, velocity, acceleration, power, &c., are referred to them. These latter units are therefore called *derived* units. The magnitudes of the fundamental units are, however, arbitrary. A large class of writers use the centimetre, gramme, and second, and this system is usually called the *C.G.S. system*; others use the foot, pound, and minute. It thus becomes important to have a systematic method of reducing measurements from one system of units to another.

Let L, M, T represent respectively the magnitude or *dimensions* of the centimetre, the gramme, and the second, and L', M', T' represent the dimensions of the foot, the pound, and the minute. Then, if a wire is found to be l cm. or l' ft. in length, its length may be represented either by lL or $l'L'$, and hence

$$lL = l'L', \text{ or, } l = \frac{L'}{L}l'.$$

The ratio $\frac{L'}{L}$ is the length of a foot in centimetres, and has been found by direct comparison to be $30\cdot4797$. Hence any measurement, l' in feet, is converted into centimetres by multiplying l' by this number.

In a similar manner, if m and m' represent the number of units of mass in a piece of matter in the two systems,

$$m = \frac{M'}{M}m',$$

where the unit ratio is the number of grammes in a pound, or $453\cdot59$.

For converting a volume v' into the equivalent v ,

$$(l'L')^3 = (lL)^3, \text{ or } l^3 = \left(\frac{L'}{L}\right)^3 l'^3,$$

$$\text{or } v = \left(\frac{L'}{L}\right)^3 v'.$$

For Density, $\frac{m}{l^3} = D$,

$$\frac{m}{l^3} \cdot \frac{M}{L^3} = \frac{m'}{l'^3} \cdot \frac{M'}{L'^3}$$

$$\text{or } D = \frac{M'}{M} \cdot \left(\frac{L}{L'}\right)^3 D'.$$

Here the ratio $\frac{M}{L^3}$ is said to be a measure of the magnitude or dimensions

of the unit of density, in terms of the dimensions of the fundamental units of mass and length. If a substance is said to have a unit density, then if M were the gramme and L^3 the cubic centimetre, the density of the substance would be that of water. If, however, M were the kilogramme and L^3 the cubic centimetre, the density would be a thousand times that of water. If, again, L^3 represent a cubic decimetre, and M a kilogramme, the density would again be that of water. It appears, then, that the magnitude of the unit of density is directly proportional to the magnitude of the unit of mass, and inversely as the magnitude of the unit of volume or the cube of the unit of length. As unit density is the density of a unit mass occupying unit volume, it is clear that $\frac{M}{L^3}$ measures the dimensions of the unit of density.

Similar explanations apply in the succeeding cases.

$$\text{For Velocity, } v = \frac{l}{t},$$

$$\frac{l}{t} \cdot \frac{L}{T} = \frac{l'}{t'} \cdot \frac{L'}{T'}$$

or

$$v = \frac{L'}{L} \frac{T}{T'} \cdot v'$$

$$\text{The ratio } \frac{T}{T'} = \frac{\text{second}}{\text{minute}} = \frac{1}{60}$$

If the units of time were the same, the unit factor $\frac{T}{T'} = 1$ and the velocity in centimetres would be

$$v = \frac{L'}{L} v',$$

where v' is the velocity in feet per second.

$$\text{For Momentum, } mv = \frac{ml}{t},$$

$$\frac{mv}{t} \cdot \frac{ML}{T} = \frac{m'l'}{t'} \cdot \frac{M'L'}{T'}$$

or

$$mv = \frac{M}{M} \frac{L'}{L} \frac{T}{T'} \cdot m'v'$$

$$\text{For Acceleration, } a = \frac{v}{t} = \frac{l}{t^2},$$

$$\frac{l}{t^2} \cdot \frac{L}{T^2} = \frac{l'}{t'^2} \cdot \frac{L'}{T'^2}$$

or

$$a = \frac{L'}{L} \left(\frac{T}{T'}\right)^2 \cdot a'$$

where a' is the acceleration in feet per minute.

$$\text{For Force, } F = ma = \frac{ml}{t^2},$$

$$\frac{ml}{t^2} \cdot \frac{ML}{T^2} = \frac{m'l'}{t'^2} \cdot \frac{M'L'}{T'^2}$$

or

$$F = \frac{M'}{M} \frac{L'}{L} \left(\frac{T}{T'}\right)^2 F'$$

In the C.G.S. system the unit of force is called the *Dyne*.

For Work, $W = Fl = \frac{ml^2}{t^2}$,

$$\frac{ml^2}{t^2} \cdot \frac{ML^2}{T^2} = \frac{m'l'^2}{t'^2} \cdot \frac{M'L'^2}{T'^2},$$

or
$$W = \frac{M'}{M} \left(\frac{L'}{L} \cdot \frac{T}{T'} \right)^2 W'.$$

In the C.G.S. system the unit of work is called the *Erg*.

Rate of Work, or Power, $P = \frac{Fl}{t} = \frac{ml^2}{t^3}$,

$$\frac{ml^2}{t^3} \cdot \frac{ML^2}{T^3} = \frac{m'l'^2}{t'^3} \cdot \frac{M'L'^2}{T'^3},$$

or
$$P = \frac{M'}{M} \left(\frac{L'}{L} \right)^2 \left(\frac{T}{T'} \right)^3 P'.$$

If work is expressed in foot-pounds or kilogramme-metres, the unit of force being the weight of a pound or kilogramme, then to convert a certain number of foot-pounds into kilogramme-metres we have

$$wl \cdot WL = w'l' W' L'.$$

$$\text{Work (kgr.-m.)} = \left(\frac{W'}{W} \cdot \frac{L'}{L} \right) \text{work, foot-pounds,}$$

$$\text{where } \frac{W'}{W} = \frac{\text{pound}}{\text{kilogr.}} = 0.4536$$

$$\frac{L'}{L} = \frac{\text{foot}}{\text{metre}} = 0.3048,$$

the unit factor being thus 0.1383.

Similarly, to convert foot-pounds per minute into kilogr.-metres per second,

$$P = \left(\frac{W'}{W} \cdot \frac{L'}{L} \cdot \frac{T}{T'} \right) P',$$

where the conversion factor becomes 0.00230.

The units commonly used for measuring the power of engines are the *horse-power*, which is 33,000 times as great as the unit in which P' of the last equation was measured, and the *force de cheval*, which is 75 times as great as the unit in which P was measured. Hence, if P' is to be in horse-power, and P in *force de cheval*, the equation will become

$$\begin{aligned} P &= 0.00230 \times \frac{33,000}{75} P' \\ &= 1.0139 P', \end{aligned}$$

and hence one British horse-power = 1.0139 *force de cheval*.

These examples will be sufficient to indicate the method of converting measurements from one system of units to any other, and the treatment of other derived units may be deferred until they are needed.

64. **Energy.**—The fact that any agent is capable of doing work is usually expressed by saying that it possesses *energy*, and the quantity of energy it

possesses is measured by the amount of work it can do. For example, in the case of the inclined plane above referred to, the energy of the force P is $P \times RS$; and if this force acts under the conditions last supposed, by the time its own energy is exhausted (in consequence of its point of application having arrived at S , the limit of the range through which it is supposed able to act), it has conferred upon the mass M a quantity of energy equal to that which has been expended; for, in the first place, M has been raised through a vertical height equal to ST , and could by falling again through the same height do an amount of work represented by $W \times ST$; and in the second place M can do work by virtue of the velocity that has been imparted to it, and can continue moving in opposition to any given resistance R through a distance s , such that

$$Rs = \frac{1}{2} Mv^2.$$

The energy possessed by the mass M in consequence of its having been raised from the ground is commonly distinguished as *energy of position* or *potential energy*, and is measured by the product of the force tending to cause motion into the distance through which the point of application of the force is capable of being displaced in the direction in which the force acts. The energy possessed by a body in consequence of its velocity is commonly distinguished as *energy of motion*, or *kinetic energy*: it is measured by half the product of the moving mass into the square of its velocity.

65. **Varieties of energy.**—On considering the definition of *work* given above, it will be seen that a force is said to do work when it produces any change in the condition of bodies; for the only changes which, according to the definition of *force* given previously (29), a force is capable of producing, are changes in the state of rest or motion of bodies, and changes of their place in opposition to resistances tending to prevent motion or to produce motion in an opposite direction. There are, however, many other kinds of physical changes which can be produced under appropriate conditions, and the recent progress of investigation has shown that the conditions under which changes of all kinds occur are so far analogous to those required for the production of work by mechanical forces that the term *work* has come to be used in a more extended sense than formerly, and is now often used to signify the production of any sort of physical change.

Thus work is said to be done when a body at a low temperature is raised to a higher temperature, just as much as when a weight is raised from a lower to a higher level; or, again, work is done when an electric, magnetic, or chemical change is produced. This extension of the meaning of the term *work* involves a similar extension of the meaning of *energy*, which in this wider sense may be defined as the *capacity for producing physical change*.

As examples of energy in this more general sense, the following may be mentioned:—(a) The energy possessed by gunpowder in virtue of the mutual chemical affinities of its constituents, whereby it is capable of doing work by generating heat or by acting on a cannon-ball so as to change its state of rest into one of rapid motion; (b) the energy of a charged Leyden jar, which, according to the way in which the jar is discharged, can give rise to changes of temperature, to changes of chemical composition, to mechanical changes,

or to changes of magnetic or electric condition ; (c) the energy of a red-hot ball, which, amongst other effects it is capable of producing, can raise the temperature and increase the volume of bodies colder than itself, or can change ice into water or water into steam ; the energy of the stretched string of a bow : here work has been consumed in stretching the string ; when it is released the work reappears in the velocity imparted to the arrow.

66. **Transformation of energy.**—It has been found by experiment that, when one kind of energy disappears or is expended, energy of some other kind is produced, and that, under proper conditions, the disappearance of any one of the known kinds of energy can be made to give rise to a greater or less amount of any other kind. One of the simplest illustrations that can be given of this transformation of energy is afforded by the oscillations of a pendulum. When the pendulum is at rest in its lowest position it does not possess any energy, for it has no power of setting either itself or other bodies in motion, or of producing in them any kind of change. In order to set the pendulum oscillating, work must be done upon it, and it thereafter possesses an amount of energy corresponding to the work that has been expended. When it has reached either end of its path, the pendulum is for an instant at rest ; but it possesses energy by virtue of its position, and can do an amount of work while falling to its lowest position, which is represented by the product of its weight into the vertical height through which its centre of gravity descends. When at the middle of its path, the pendulum is passing through its position of equilibrium, and has no power of doing work by falling lower ; but it now possesses energy by virtue of the velocity which it has gained, and this energy is able to carry it up on the second side of its lowest position to a height equal to that from which it has descended on the first side. By the time it reaches this position the pendulum has lost all its velocity, but it has regained the power of falling ; this, in its turn, is lost as the pendulum returns again to its lowest position, but at the same time it regains its previous velocity. Thus, during every quarter of an oscillation the energy of the pendulum changes from potential energy of position into actual energy or energy of motion, or *vice versâ*.

A more complex case of the transformation of energy is afforded by a thermo-electric pile, the terminals of which are connected by a conducting wire : the application of energy in the form of heat to one face of the pile gives rise to an electric current in the wire, which, in its turn, reproduces heat, or by proper arrangements can be made to produce chemical, magnetic, or mechanical effects, such as those described below in the chapters on Electricity.

It has also been found that the transformations of energy always take place according to fixed proportions. For instance, when coal or any other combustible is burned, its chemical energy, or power of combining with oxygen, vanishes, and heat or thermal energy is produced, and the quantity of heat produced by the combustion of a given amount of coal is fixed and invariable. If the combustion takes place under the boiler of a steam-engine mechanical work can be obtained by the expenditure of part of the heat produced, and here again the quantitative relation between the heat expended and the work gained in place of it is perfectly constant.

67. **Conservation of energy.**—Another result of great importance, which has been arrived at by experiment, is that the total amount of energy possessed by any system of bodies is unaltered by any transformations arising from the action of one part of the system upon another, and can only be increased or diminished by effects produced on the system by external agents. In this statement it is of course understood that in reckoning the sum of the energy of various kinds which the system may possess, those amounts of the different forms of energy which are mutually convertible into each other are taken as being numerically equal ; or, what comes virtually to the same thing, the total energy of the system is supposed to be reduced—either actually, or by calculation from the known ratio of transformation of the various forms of energy—to energy of some one kind ; then the statement is equivalent to this : that the total energy of any one form to which the energy of a given system of bodies is reducible is unalterable so long as the system is not acted on from without. Practically it is always possible, in one way or another, to convert the whole of the energy possessed by any body or system of bodies into heat, but it cannot be all converted without loss into any other form of energy ; hence the principle stated at the beginning of this article can be enunciated in the closest conformity with the direct results of experiment by saying that, so long as any system of bodies is not acted on from without, the total quantity of heat that can be obtained from it is unalterable by any changes which may go on within the system itself. For instance, a quantity of air compressed into the reservoir of an air-gun possesses energy which is represented partly by the heat which gives to it its actual temperature above the absolute zero (337), and partly by the work which the air can do in expanding. This latter portion can be converted into heat in various ways, as, for example, by allowing the air to escape through a system of capillary tubes so fine that the air issues from them without any sensible velocity ; if, however, the expanding air be employed to propel a bullet from the gun, it produces considerably less heat than in the case previously supposed, the deficiency being represented for a time by the energy of the moving bullet, but reappearing in the form of heat in the friction of the bullet against the air, and, when the motion of the bullet is destroyed, by striking against an inelastic obstacle at the same level as the gun. But whatever the mode and however numerous the intermediate steps by which the energy of the compressed air is converted into heat, the total quantity of heat finally obtainable from it is the same.

BOOK II

GRAVITATION AND MOLECULAR ATTRACTION

CHAPTER I

GRAVITY. CENTRE OF GRAVITY. THE BALANCE

68. **Universal attraction : its laws.**—*Universal attraction* is a force in virtue of which the material particles of all bodies tend incessantly to approach each other ; it is an action, however, which all bodies, at rest or in motion, exert upon one another, no matter how great or how small the space between them may be, or whether this space be occupied or unoccupied by other matter.

A vague hypothesis of the tendency of the matter of the earth and stars to a common centre was adopted even by Democritus and Epicurus. Kepler assumed the existence of a mutual attraction between the sun, the earth, and the other planets. Bacon, Galileo, and Hooke also recognised the existence of universal attraction. But Newton was the first who established the law, and the universality of gravitation.

After Newton's time the attraction of matter by matter was experimentally established by Cavendish. This eminent English physicist succeeded, by means of a delicate torsion balance (89), in rendering visible the attraction between a large leaden and a small copper ball.

The attraction between any two bodies is the resultant of the attractions of each molecule of the one upon every molecule of the other according to the law of Newton, which may be thus expressed: *the attraction between two material particles is directly proportional to the product of their masses and inversely proportional to the square of their distances asunder.* To illustrate this, we may take the case of two spheres, which, owing to their symmetry, attract each other just as if their masses were concentrated in their centres. If without other alteration the mass of one sphere were doubled, tripled, &c., the attraction between them would be doubled, tripled, &c. If, however, the mass of one sphere being doubled, that of the other were increased three times, the distance between their centres remaining the same, the attraction would be increased six times. Lastly, if, without altering their masses, the distance between their centres were *increased* from 1 to 2, 3, 4 units, the attraction would be *diminished* to the 4th, 9th,

16th part of its former intensity. Thus, $F = G \frac{mm'}{r^2}$, where m, m' are the masses of the spheres, r the distance between their centres, F the force between them, and G the Newtonian constant of gravitation. Cavendish measured F with known values of m, m' , and r , and so determined G . Cavendish's experiment has been repeated by Cornu, Boys, and others. The value of G , according to the most recent experiments, is 6.6579×10^{-8} in C.G.S. units.

69. **Terrestrial gravitation.**—The tendency of any body to fall towards the earth is due to the mutual attraction of that body and the earth, or to terrestrial gravitation, and is, in fact, merely a particular case of universal attraction.

At any point of the earth's surface, the direction of gravity—that is, the line which a falling body describes—is called the *vertical* line. The vertical lines drawn at different points of the earth's surface converge very nearly to the earth's centre. For points situated on the same meridian the angle contained between the vertical lines equals the difference between the latitudes of those points.

The directions of the earth's attraction upon neighbouring bodies, or upon different molecules of one and the same body, must therefore be considered as parallel, for the two vertical lines form the sides of a triangle whose vertex is near the earth's centre, about 4000 miles distant, and whose base is the small distance between the molecules under consideration.

A plane or line is said to be *horizontal* when it is perpendicular to the vertical line.

The vertical line at any point of the globe is generally determined by the *plumb-line* (fig. 46), which consists of a weight attached to the end of a string.

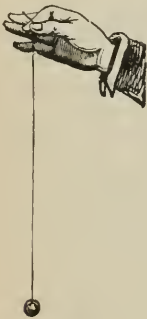

Fig. 46

It is evident that the weight cannot be in equilibrium unless the direction of the earth's attraction upon it passes through the point of support, and therefore coincides with that of the string.

The horizontal plane is also determined with great ease, since it coincides, as will be afterwards shown, with the *level* surface of every liquid when in a state of equilibrium.

When the mean figure of the earth has been approximately determined, it becomes possible to compare the direction of the plumb-line at any place with that of the normal to the mean figure at that place. When any difference in these directions can be detected, it constitutes a *deviation* of the plumb-line, and is due to the attraction of some great mass of matter in the neighbourhood, such as a mountain. Thus, in the case of the mountain of Schiehallion, in Perthshire, it was found by Dr. Maskelyne that the angle between the directions of two plumb-lines, one at a station to the north, and the other to the south, of the mountain was greater by $11.6''$ than the angle between the normals of the mean surface of the earth at those points; in other words, each plumb-line was deflected by about $6''$ towards the mountain. By calculating the volume and mass of the mountain, it was inferred from this observation

that the mean density of the mountain was to that of the earth in the ratio of 5 : 9, and that the mean density of the earth is about five times that of water.

The mean density of the earth is calculated from Cavendish's experiment as follows :—In the formula $F = G \frac{mm'}{r^2}$, let $m' = 1$ gramme, and $m =$ the mass of the earth, concentrated at its centre, $r = 4000$ miles $= 6.4 \times 10^8$ c.m. ; then $F = g$ dynes, and $g = G \frac{m}{r^2}$, whence m is determined, and hence the mean density, which is the mass of the earth divided by its volume. If G is taken $= 6.6579 \times 10^{-8}$, the mean density $= 5.527$.

70. **Centre of gravity: its experimental determination.**—Into whatever position a body may be turned with respect to the earth, there is a certain point invariably situated with respect to the body, through which the resultant of the attracting forces between the earth and its several molecules always passes. This point is called the *centre of gravity* ; it may be within or without the body, according to the form of the latter ; its existence, however, is easily established by the following considerations : let $m m' m'' \dots$ (fig. 47) be molecules of any body. The earth's attraction upon these molecules will constitute a system of parallel forces, having a common

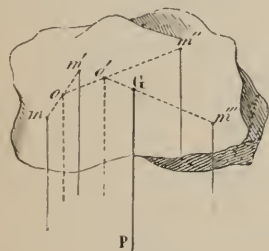

Fig. 47

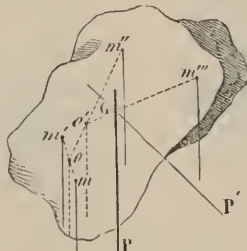

Fig. 48

vertical direction, whose resultant will be found by seeking first the resultant of the forces which act on any two molecules, m and m' , then that of this resultant and a third force acting on m'' , and so on until we arrive at the final resultant W , representing the weight of the body and applied at a certain point G . If the body is now turned into the position shown in fig. 48, the molecules $m m' m'' \dots$ will continue to be acted on by the same forces as before, the resultant of the forces on m and m' will pass through the same point o in the line mm' , the following resultant will again pass through the same point o' in om'' , and so on up to the final resultant P , which will still pass through the same point G , which is the *centre of gravity*.

To find the centre of gravity of a body is a purely geometrical problem ; in many cases, however, it can be at once determined. For instance, the centre of gravity of a right line or fine straight wire of uniform density is the point which bisects its length ; in the circle and sphere it coincides with the geometrical centre ; in cylindrical bars it is the middle point of the axis.

The centre of gravity of a plane triangle is in the line which joins any vertex with the middle of the opposite side, and at a distance from the vertex equal to two-thirds of this line : in a cone or pyramid it is in the line which joins the vertex with the centre of gravity of the base, and at a distance from the vertex equal to three-fourths of this line. These rules, it must be remembered, presuppose that the several bodies are of uniform density.

In order to determine experimentally the centre of gravity of a body, it is suspended by a string in two different positions, as shown in figs. 49 and 50 ; the point where the directions AB and CD of the string in the two experiments intersect each other is the centre of gravity required. For, the resultant of the earth's attraction being a vertical force applied at the centre of gravity, the body can only be in equilibrium when the point lies vertically under the point of suspension ; that is, in the prolongation of the suspended string. But the centre of gravity being in AB as well as in CD, must coincide with the point of intersection of these two lines.



Fig. 49

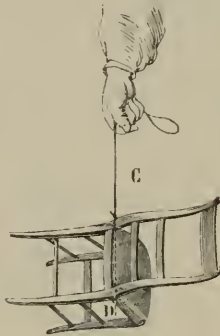

Fig. 50

The centre of gravity of a thin piece of cardboard of irregular shape, for instance, may be found by balancing it in two positions on a knife-edge ; the centre of gravity will then lie in the intersection of the two lines.

71. Equilibrium of heavy bodies.—Since the action of gravity upon a body reduces itself to a single vertical force applied at the centre of gravity and directed towards the earth's centre, equilibrium

will be established only when this resultant is balanced by the resultant of other forces and resistances acting on the body at the fixed point through which it passes.

When only one point of the body is fixed, it will be in equilibrium if the vertical line through its centre of gravity passes through the fixed point. If more than one point is supported, the body will be in equilibrium if a vertical line, through the centre of gravity, passes through a point within the polygon formed by joining the points of support.

The Leaning Tower of Pisa continues to stand because the vertical line drawn through its centre of gravity passes within its base.

It is easier to stand on our feet than on stilts, because in the latter case the smallest motion is sufficient to cause the vertical line through the centre of gravity of our bodies to pass outside the supporting base, which is here reduced to a mere line joining the feet of the stilts. A man carrying a load on his back must lean forward : if he carries it in the left hand he must incline the upper part of his body to the right, for otherwise the centre of gravity of the body and of the load would fall outside the line joining the feet, and he would fall. Again, it is impossible to stand on one leg if we keep one side of the foot and head close to a vertical wall, because the latter prevents

us from throwing the body's centre of gravity vertically above the supporting base.

72. **Different states of equilibrium.**—Although a body supported by a fixed point is in equilibrium whenever its centre of gravity is in the vertical line through that point, the fact that the centre of gravity tends incessantly to occupy the lowest possible position leads us to distinguish between three states of equilibrium—*stable, unstable, neutral*.

A body is said to be in *stable equilibrium* if it tends to return to its first position after the equilibrium has been slightly disturbed. Every body is in this state when its position is such that the slightest alteration of the same elevates its centre of gravity; for the centre of gravity will descend again when permitted, and after a few oscillations the body will return to its original position.

The pendulum of a clock continually oscillates about its position of stable equilibrium, and an egg on a level table is in this state when its long axis is horizontal. We have another illustration in the toy represented in the adjoining fig. 51. A small figure cut in ivory is made to stand on one foot at the top of a pedestal by being loaded with two leaden balls, *a, b*, placed sufficiently low to throw the centre of gravity *g* of the whole compound body below the foot of the figure. After being disturbed, the little figure oscillates like a pendulum, having its point of suspension at the toe, and its centre of gravity at a lower point, *g*.

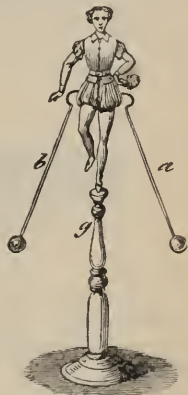

Fig. 51

A body is said to be in *unstable equilibrium* when, after the slightest disturbance, it tends to depart still more from its original position. A body is in this state when its centre of gravity is vertically above the point of support, or higher than it would be in any adjacent position of the body. An egg standing on its end, or a stick balanced upright on the finger, is in this state.

Lastly, if in any adjacent position a body still remains in equilibrium, its state of equilibrium is said to be *neutral*. In this case an alteration in the position of the body neither raises nor lowers its centre of gravity. A perfect sphere resting on a horizontal plane is in this state.

Fig. 52 represents three cones, A, B, C, placed respectively in stable, unstable, and neutral equilibrium upon a horizontal plane. The letter *g* in each shows the position of the centre of gravity.

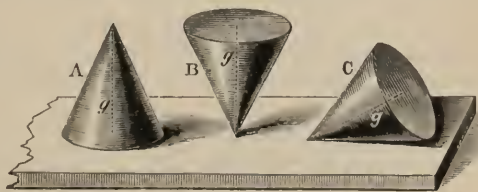

Fig. 52

73. **The balance.**—The balance is an instrument for determining the relative weights or masses of bodies. There are many varieties.

The ordinary balance (fig. 53) consists of a lever of the first kind, called

the *beam*, AB, with its fulcrum in the middle ; at the extremities of the beam are suspended two scale-pans, C and D, one intended to receive the object to be weighed, and the other the counterpoise. The fulcrum consists of a steel prism, *n*, commonly called a *knife-edge*, which passes through the beam, and rests with its sharp edge, or *axis of suspension*, upon two supports ; these are formed of agate, in order to diminish the friction. A needle or pointer is fixed to the beam, and oscillates with it in front of a graduated arc : when the beam is perfectly horizontal the needle points to the zero of the graduated arc (fig. 57).

Since two equal forces in a lever of the first kind cannot be in equilibrium unless their leverages are equal (43), the length of the arms *nA* and *nB* ought to remain equal during the process of weighing. To secure this the scale-pans are suspended from hooks, whose curved parts have sharp



Fig. 53

edges, and rest on similar edges at the ends of the beam. In this manner the scale-pans are in effect supported on mere points, which remain unmoved during the oscillations of the beam. This mode of suspension is represented in fig. 53.

74. **Conditions to be satisfied by a balance.**—A good balance ought to satisfy the following conditions :—

i. *The two arms of the beam ought to be precisely equal ;* otherwise, according to the principle of the lever, unequal weights will be required to produce equilibrium. To test whether the arms of the beam are equal, weights are placed in the two scale-pans, until the beam becomes horizontal ; the contents of the pans being then interchanged, the beam will remain horizontal if its arms are equal, but if not, it will descend on the side of the longer arm.

ii. *The balance ought to be in equilibrium when the scale-pans are empty, for otherwise unequal weights must be placed in the pans in order to produce equilibrium. It must be borne in mind, however, that the arms are not necessarily equal, even if the beam remains horizontal when the scale-pans are empty; for this result might also be produced by giving to the longer arm the lighter scale.*

iii. *The beam being horizontal, its centre of gravity ought to be in the same vertical plane with the edge of the fulcrum, and a little below the latter, for otherwise the beam would not be in stable equilibrium (72).*

The effect of changing the position of the centre of gravity may be shown by means of a beam (fig. 54), whose fulcrum, being the nut of a screw, *a*, can be raised or lowered by turning the screw head, *b*.

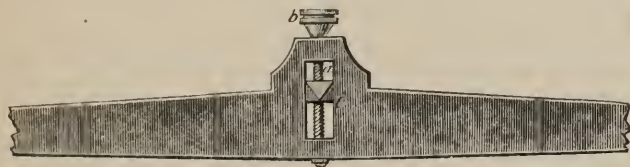

Fig. 54

When the fulcrum is at the top of the groove *c*, in which it slides, the centre of gravity of the beam is below its edge, and the latter oscillates freely about a position of stable equilibrium. By gradually lowering the fulcrum its edge may be made to pass through the centre of gravity of the beam when the latter is in neutral equilibrium; that is to say, it no longer oscillates, but remains in equilibrium in all positions. When the fulcrum is lowered still more, the centre of gravity passes above its edge, the beam is in a state of unstable equilibrium, and is overturned by the least displacement.

75. **Delicacy of the balance.**—A balance is said to be *delicate* or *sensible* when a very small difference between the weights in the scale-pans causes a perceptible deflection of the pointer.

Let *A* and *B* (figs. 55 and 56) be the points from which the scale-pans are suspended, and *C* the axis of suspension of the beam. *A*, *B*, and *C* are



Fig. 55

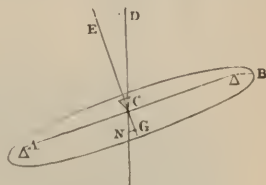

Fig. 56

assumed to be in the same straight line, according to the usual arrangement. Suppose weights *P* and *Q* to be in the pans, suspended from *A* and *B* respectively, and let *G* be the centre of gravity of the beam; then the beam will come to rest in the position shown in the figure, where the line *DCN* is

vertical, and ECG is the direction of the pointer. According to the above statement, the greater the angle ECD for a given difference between P and Q, the greater is the sensibility of the balance. Draw GN at right angles to CG.

Let W = the weight of the beam, $2a$ = the length of the beam, and $CG = h$, then, from the properties of the lever (43) it follows that, measuring moments with respect to C, the moment of P equals the sum of the moments of Q and W, a condition which at once leads to the relation

$$(P - Q)AC = W \times GN ;$$

or, since $GN = h \tan \theta$, where θ = the angle DCE,

$$\tan \theta = \frac{(P - Q) a}{hW}.$$

From this we learn that for a given value of $P - Q$ (e.g. 1 milligramme), $\tan \theta$, and therefore θ , is greater as a is greater, and h and W less. Hence the means of rendering a balance delicate are—

- i. To make the arms of the balance long.
- ii. To make the weight of the beam as small as is consistent with its rigidity.
- iii. To bring the centre of gravity of the beam a very little below the point of support.

If the arms of the balance were long there would be a tendency for the beam to bend when the pans are loaded; consequently, a is usually not

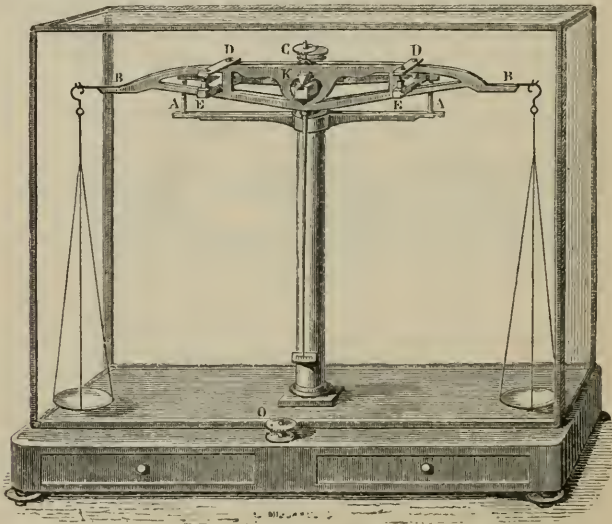

Fig. 57

more than about 15 cm., and sensitiveness is secured by making W , or h , or both, small. The weight of the beam is reduced as far as possible, without diminishing its rigidity, by portions of it being cut away (fig. 57). The posi-

tion of the centre of gravity of the beam and pointer is controlled by the circular nut, C, which works on a screw immediately over the pointer; by raising the nut we may make h as small as we please, and so increase the sensitiveness.

The sensitiveness of a balance is expressed by the angle of deflection of the beam when the weights in the pans differ by a milligramme.

76. **Physical and chemical balances.**—Fig. 57 represents one of the accurate balances ordinarily used for chemical analysis. Its sensitiveness is such that when charged with a kilogramme (1000 grms.) in each scale an excess of a tenth of a milligramme ($\frac{1}{10000}$ of a gm.) in either scale produces a very perceptible deflection of the index.

In order to protect the balance from air currents, dust, and moisture, it is always, even during a weighing, surrounded by a glass case, whose front slides up and down, to enable the operator to introduce the object to be weighed and the balancing weights. Where extreme accuracy is desired the case is constructed so that the space may be exhausted, and the weighing made *in vacuo*.

In order to preserve the edge of the fulcrum as much as possible, the whole beam, BB, with its fulcrum K, can be raised from the support on which the latter rests by simply turning the button O outside the case.

77. **Method of double weighing.**—Even if a balance is not perfectly accurate, the true weight of a body may still be determined by its means. To do so, the body to be weighed is placed in one scale, and shot or sand poured into the other until equilibrium is produced; the body is then replaced by known weights until equilibrium is re-established. The sum of these weights will necessarily be equal to the weight of the body, for, acting under precisely the same circumstances, both have produced precisely the same effect.

The exact weight of a body may also be determined by placing it successively in the two pans of a balance, and then deducing its true weight.

For having placed in one pan the body to be weighed, whose true weight is x ; and in the other the weight p , required to balance it, let a and b be the arms of levers corresponding to x and p . Then from the principle of the lever (43) we have $ax = pb$. Similarly, if p_1 is the weight when the body is placed in the other pan, then $bx = ap_1$. Hence $abx^2 = abpp_1$, from which $x = \sqrt{pp_1}$. This method was invented by Pèrre Amiot, but is ordinarily known as *Borda's Method*.

If p and p_1 do not differ much from each other, $\sqrt{pp_1} = \frac{1}{2}(p + p_1)$; for example, if a body weigh 43·479 grammes in one pan and 43·471 in the other, its true weight is 43·475.

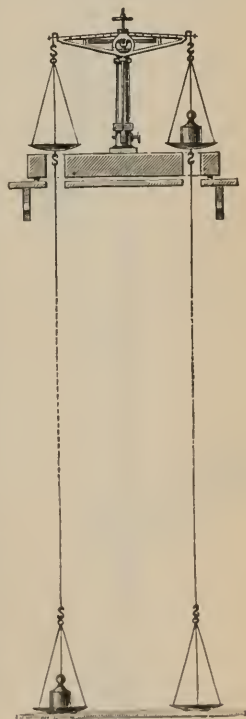

Fig. 58

Jolly made use of a very sensible balance to determine the constant of gravity. The balance (fig. 58) was placed in a room in the tower of the University of Munich, and to each of the scale-pans was attached, by a wire 21 metres in length, a second scale-pan. A mass of mercury of 5 kilogrammes contained in a glass vessel was first counterpoised in the upper scale-pan ; it was then moved to the lower one, and it was found necessary to add 31.683 mgr. to the upper pan in order to counterbalance the increase in attractiveness due to the greater force in the lower pan.

Taking the radius of the earth at Munich at 6,365,722 metres, the number calculated from the formula in (84) is 33 mgr. ; a sufficiently close result when the difficulties of the experiments are taken into account.

A large lead sphere was then placed immediately below the mass in the lower pan, and produced a measurable attraction. From the attraction thus produced by the known mass of the lead it was possible to deduce the mass and the mean density of the earth (69, 70) ; the number obtained was 5.69. Similar experiments made by Professor Poynting have led to the number 5.5.

CHAPTER II

LAWS OF FALLING BODIES. INTENSITY OF TERRESTRIAL GRAVITY.
THE PENDULUM

78. **Laws of falling bodies.**—Since a body falls to the ground in consequence of the earth's attraction on *each* of its molecules, it follows that, everything else being the same, all bodies, great and small, light and heavy, ought to fall with equal rapidity, and a lump of sand without cohesion should during its fall retain its original form as perfectly as if it were compact stone. The fact that a stone falls more rapidly than a feather is due solely to the unequal resistance opposed by the air to the descent of these bodies ; *in a vacuum all bodies fall with equal rapidity.* To demonstrate this by experiment a glass tube about two yards long (fig. 59) may be taken, having one of its ends completely closed, and a brass cock fixed to the other. After bodies of different weights and densities (pieces of lead, paper, feathers, &c.) have been introduced into the tube, the air is withdrawn from it by an air-pump, and the cock closed. If the tube be now suddenly reversed, all the bodies will fall equally quickly. On introducing a little air and again inverting the tube, the lighter bodies become slightly retarded, and this retardation increases with the quantity of air introduced.

The resistance opposed by the air to falling bodies is especially remarkable in the case of liquids. The Staubbach in Switzerland is a good illustration ; an immense mass of water is seen falling over a high precipice, but before reaching the bottom it is shattered by the air into the finest mist. In a vacuum, however, liquids fall like solids without separation of their molecules. The *water-hammer* (fig. 60) illustrates this : the instrument consists of a thick glass tube about a foot long, half filled with water, the air having been expelled by ebullition previous to closing one extremity with the blow-pipe. When such a tube is suddenly inverted, the water falls in one undivided mass against the



Fig. 59

other extremity of the tube, and produces a sharp dry sound, resembling that which accompanies the shock of two solid bodies.

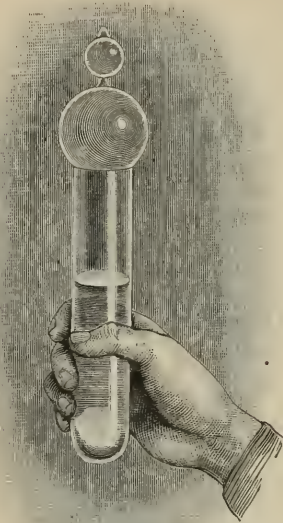

Fig. 60

From Newton's law (68) it follows that when a body falls to the earth the force of attraction which causes it to do so increases as the body approaches the earth. Unless the height from which the body falls, however, is very great, this increase will be altogether inappreciable, and the force in question may be considered as constant and continuous. If the resistance of the air were removed, therefore, the motion of all bodies falling to the earth would be uniformly accelerated, and would obey the laws already explained (52).

79. **Atwood's Machine.**—Several instruments have been invented for illustrating and experimentally verifying the laws of falling bodies. Galileo, who discovered these laws in the early part of the seventeenth century, illustrated them by means of bodies falling down inclined planes. The great object of all such instruments is to diminish the rapidity of the fall of bodies without altering the character of their motion, for by this

means their motion may not only be better observed, but it will be less modified by the resistance of the air (50).

The most convenient instrument of this kind is that invented by Atwood at the end of the eighteenth century, and represented in fig. 61. It consists of a stout pillar of wood, about $2\frac{1}{2}$ yards high, at the top of which is a brass pulley, whose axle rests and turns upon four other wheels, called *friction wheels*, inasmuch as they serve to diminish friction. Two equal weights, *M* and *M'*, are attached to the extremities of a fine silk thread, which passes round the pulley; a timepiece, *H*, fixed to the pillar, is regulated by a seconds pendulum, *P*, in the usual way; that is to say, the oscillations of the pendulum are communicated to an escapement, whose two teeth, as seen in the figure, fit into those of the ratchet wheel. The axle of this wheel gives motion to the seconds hand of the dial, and also to an eccentric behind the dial, as shown at *E* by a separate figure. This eccentric plays against the extremity of a lever, *D*, which it pushes until the latter no longer supports the small plate *i*; and thus the weight *M*, which at first rested on this plate, is suddenly exposed to the free action of gravity. The eccentric is so constructed that the little plate *i* falls precisely when the hand of the dial points to zero.

The weights, *M* and *M'*, being equal, hold each other in equilibrium; the weight *M*, however, is made to descend slowly by putting a small bar or overweight *m* upon it; and, to measure the spaces which it describes, the rod

or scale Q is divided into feet and inches, commencing from the plate *i*. To complete the instrument there are a number of plates, A, A', C, C', and a number of rings, B, B', which may be fixed by screws at any part of the scale. The plates arrest the descending weight M, the rings only arrest the bar or overweight *m*, which was the cause of motion, so that after passing through a ring the weight M, in consequence of its inertia, will move on uniformly with the velocity it had acquired on reaching the ring. The several parts of the apparatus being described, a few words will suffice to explain the method of experimenting.

Let the hand of the dial be placed behind the zero point, the lever D adjusted to support the plate *i*, on which the weight M with its overweight *m* rests, and the pendulum put in motion. As soon as the hand of the dial points to zero, the plate *i* will fall, the weights M and *m* will descend, and by a little attention and a few trials it will be easy to place a plate A so that M may reach it exactly as the dial indicates the expiration of one second. To make a second experiment let the weights M and *m*, the plate *i*, and the lever D be placed as at first; remove the plate A, and in its place put a ring, B, so as to arrest the overweight *m* just when the weight M would have reached A; on putting the pendulum in motion again it will be easy, after a few trials, to put a plate, C, so that the weight M may fall upon it precisely when the hands of the dial point to two seconds.

Since the overweight *m* in this experiment was arrested by the ring B at the expiration of one second, the space BC was described by M in one second purely in virtue of its own

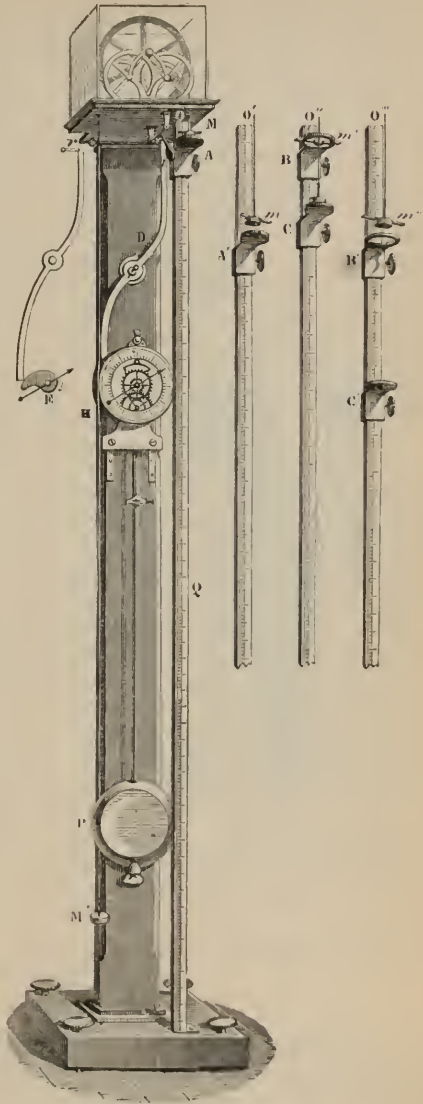

Fig. 61

inertia, and consequently (32) BC will indicate the velocity of the falling mass at the expiration of one second.

Proceeding in the same manner as before, let a third experiment be made in order to ascertain the point B' at which the weights M and m arrive after the lapse of two seconds, and putting a ring at B', ascertain by a fourth experiment the point C' at which M arrives alone, three seconds after the descent commenced; B'C' will then express the velocity acquired after a descent of two seconds. In a similar manner, by a fifth and sixth experiment, we may determine the space OB'' described in three seconds, and the velocity B''C'' acquired during those three seconds, and so on; we shall find that B'C' is twice and B''C'' three times as great as BC—in other words, that the velocities BC, B'C', B''C'' increase in the same proportion as the times (1, 2, 3, . . . seconds) employed in their acquirement. By the definition (51), therefore, the motion is uniformly accelerated. The same experiments will also serve to verify and illustrate the four laws of uniformly accelerated motion as enunciated in 51. For example, the spaces OB, OB', OB'', . . . described from a state of rest in 1, 2, 3, . . . seconds, will be found to be proportional to the numbers 1, 4, 9 . . . ; that is to say, to the squares of those numbers of seconds, as stated in the third law.

Lastly, if the overweight m is changed, the acceleration or velocity BC acquired per second will also be changed, and we may easily verify the assertion (30) that force is proportional to the product of the mass moved, into the acceleration produced in a given time. For instance, assuming the pulley to be so light that its inertia can be neglected, then if m weighed half an ounce, and M and M' each $15\frac{3}{4}$ ounces, the acceleration BC would be found to be six inches; whilst if m weighed one ounce, and M and M' each $63\frac{1}{2}$ ounces, the acceleration BC would be found to be three inches.

Now in these cases the forces producing motion, that is the overweights, are in the ratio of 1 : 2; while the products of the masses and the accelerations are in the ratio of $(\frac{1}{2} + 15\frac{3}{4} + 15\frac{3}{4}) \times 6$ to $(1 + 63\frac{1}{2} + 63\frac{1}{2}) \times 3$; that is, they are also in the ratio 1 : 2. Now the same result is obtained in whatever way the magnitudes of m , M, and M' are varied, and consequently in all cases the ratio of the forces producing motion equals the ratio of the momenta generated.

To determine the value of g we may make use of the formula of article 30, viz. $F = Mf$, where F is the force acting upon a mass M, and f is the resulting acceleration. When the weight of m (i.e. mg) puts the mass $m + M + M'$ in motion, let the acceleration be f ; then

$$mg = (m + M + M')f;$$

whence g is determined. If $f = 3$ inches, the unit of time being one second,

$$m = \frac{1}{2} \text{ oz.}, \text{ and } M = M' = 15\frac{3}{4};$$

$$\frac{1}{2}g = (\frac{1}{2} + 15\frac{3}{4} + 15\frac{3}{4}) \frac{1}{2}, \text{ and } g = 32.$$

80. Morin's apparatus.—The principle of this apparatus, the original idea of which is due to General Poncelet, is to make the falling body trace its own path. Fig. 62 gives a view of the whole apparatus, and fig. 63 gives the details. The apparatus consists of a wooden framework, about 7 feet high, which holds in a vertical position a very light wooden cylinder, M, which can turn freely about its axis. This cylinder is coated with paper divided into squares by equidistant horizontal and vertical lines. The latter

measure the path traversed by the body falling along the cylinder, while the horizontal lines are intended to divide the duration of the fall into equal parts.

The falling body is a mass of iron, P, provided with a pencil, which is pressed against the paper by a small spring. The iron is guided in its fall by two light iron wires which pass through guide-holes on the two sides. The top of this mass is provided with a tipper which catches against the end

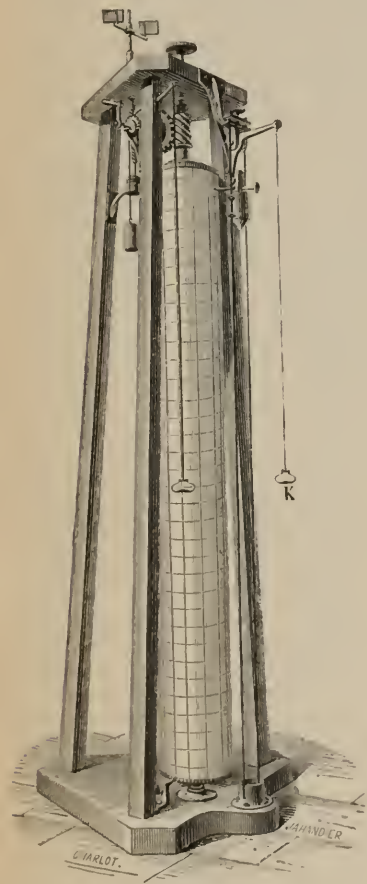

Fig. 62

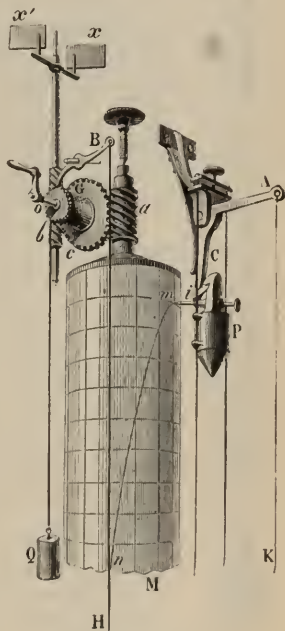

Fig. 63

of a bent lever, AC. This being pulled by the string K attached at A, the weight falls. If the cylinder M was fixed, the pencil would trace a straight line on it; but if the cylinder moves uniformly, the pencil traces the line *mn*, from which the law of the fall may be deduced.

The cylinder is rotated by means of a weight, Q, suspended to a cord which passes round the axle G. At one end of this is a toothed wheel c,

which turns two endless screws, a and b , one of which is connected to the axis of the cylinder, and the other to the two vanes x and x' (fig. 63). At the other end is a ratchet wheel, in which fits the end of a lever, B; by pulling at a cord fixed to the other end of B, the wheel is liberated, the weight Q descends, and the whole system begins to turn. The motion is at first accelerated, but as the air offers a resistance to the vanes (50), which increases as the rotation becomes more rapid, the resistance finally equals the acceleration which gravity tends to impart. From this time the motion becomes uniform. This

is the case when the weight Q has traversed about three-quarters of its course; at this moment the weight P is detached by pulling the cord K, and the pencil then traces the curve mn .

If, by means of this curve, we examine the double motion of the pencil on the small squares which divide the paper, we see that for displacements 1, 2, 3 . . . in a horizontal direction, the displacements are 1, 4, 9 . . . in a vertical direction. This shows that the paths traversed in the direction of the fall are directly as the squares of the lines in the direction of the rotation, which verifies the second law of falling bodies.

From the relation which exists between the two dimensions of the curve mn , it is concluded that this curve is a *parabola* (53).

81. **The length of the compound pendulum.**—The formula deduced in art. 56, and the conclusions which follow therefrom, refer to the case of the simple or mathematical pendulum; that is, to a single heavy point suspended by a thread without weight. Such a pendulum has only an imaginary existence, and any pendulum which does not realise these conditions is called a *compound* or *physical* pendulum. The laws for the time of vibration of a compound pendulum vibrating about an axis (axis of suspension) are the same as those for a simple pendulum, though it will be necessary to define accurately what is meant by the *length* of such a pendulum. A compound pendulum being formed of a heavy rod terminated by a greater or less mass, it follows that the several material points of the whole system will strive to perform their oscillations in different times, their distances from the axis of suspension being different, and the more distant points requiring a longer time to complete an oscillation. From this, and from the fact that being points of the same body they must all oscillate together, it follows that the motion of the points near the axis of suspension will be retarded, whilst that of the more distant points will be accelerated, and between the two extremities there will necessarily be a series



Fig. 64

of points whose motion will be neither accelerated nor retarded, but which will oscillate precisely as if they were perfectly free and unconnected with the other points of the system. These points, being equidistant from the axis of suspension, constitute a parallel axis known as the *axis of oscillation*; and it is to the distance between these two axes that the term *length of the compound pendulum* is applied: we may say, therefore, that *the length of a compound pendulum is that of the simple pendulum which would describe its oscillations in the same time.*

Huyghens, the celebrated Dutch physicist, discovered that the axes of suspension and oscillation are mutually convertible; that is to say, the time of oscillation will remain unaltered when the pendulum is suspended from its axis of oscillation. This enables us to determine experimentally the length of the compound pendulum. For this purpose the *reversible pendulum* devised by Bohnenberger and Kater may be used. One form of this (fig. 64) is a rod with the knife-edges *a* and *b* turned towards each other. *W* and *V* are sliding masses the relative positions of which may be varied. By a series of trials a position can be found such that the number of oscillations of the pendulum in a given time is the same whether it oscillates about the axis *a* or the axis *b*. This being so, the distance *ab* represents the length *l* of a simple pendulum which has the same period. From the value of *l*, thus obtained, it is easy to determine the length of the seconds pendulum.

The length of the seconds pendulum—that is to say, of the pendulum which makes half a complete oscillation (to *or* fro motion) in a second—varies, of course, with the force of gravity. The following table gives its value at the sea-level at various places as determined by observation. The accelerative effect of gravity at these places (56) is obtained in feet and metres, by multiplying the length of the seconds pendulum, expressed in feet and metres respectively, by the square of 3·14159 or 9·8696.

	Latitude	Length of seconds Pendulum in inches	Acceleration of Gravity in	
			Foot-second units	Metre-second units
Hammerfest . . .	70°40' N	39·1948	32·2364	9·8258
Aberdeen . . .	57·9	39·1550	32·2066	9·8164
Königsberg . . .	54·42	39·1507	32·2002	9·8142
Manchester . . .	53·29	39·1466	32·1968	9·8134
Dublin . . .	53·21	39·1461	32·1963	9·8132
Berlin . . .	52·30	39·1439	32·1945	9·8124
Greenwich . . .	51·29	39·1398	32·1912	9·8115
Paris . . .	48·50	39·1285	32·1819	9·8085
Rome . . .	41·54	39·1145	32·1703	9·8064
New York . . .	40·43	39·1012	32·1594	9·8019
Washington . . .	38·54	39·0968	32·1558	9·8006
Madras . . .	13·4	39·0268	32·0982	9·7836
Ascension . . .	7·56	39·0242	32·0961	9·7817
St. Thomas Island .	0·25	39·0207	32·0932	9·7815
Cape of Good Hope	33·55 S.	39·0780	32·1404	9·7962

Consequently, $\frac{1}{2}g$ or the space described in the first second of its motion by a body falling *in vacuo* from a state of rest (51) is

16·0466 feet or 4·891 metres at St. Thomas Island
 16·0956 „ „ 4·905 „ at London, and
 16·1182 „ „ 4·913 „ at Hammerfest.

In all calculations, which are merely used for the sake of illustration, we may take 32 feet, or 9·8 metres, as the acceleration due to gravity.

The metre (22) and the length of the seconds pendulum differ, at Greenwich, by less than a quarter of an inch.

From observations with the pendulum, after applying the necessary corrections, and taking into account the effect of rotation (84), the form of the earth can be deduced.

82. **Verification of the laws of the pendulum.**—In order to verify the laws of the simple pendulum (56) we are compelled to employ a pendulum which, though not strictly simple, is made to differ as little as possible from the simple pendulum. It consists of a small sphere of a very dense substance, such as lead or platinum, suspended from a fixed point by means of a very fine metal wire. A pendulum thus formed oscillates almost like a simple pendulum, whose length is equal to the distance of the centre of the sphere from the point of suspension.

In order to verify the isochronism of small oscillations, it is merely necessary to count the number of oscillations made in equal times, as the amplitudes of these oscillations diminish from 3 degrees to a fraction of a degree ; this number is found to be constant.

That the time of vibration is proportional to the square root of the length is verified by causing pendulums, whose lengths are as the numbers 1, 4, 9, . . . to oscillate simultaneously. The corresponding numbers of oscillations in a given time are then found to be proportional to the fractions $1, \frac{2}{3}, \frac{1}{2}$, &c., . . . which shows that the times of oscillation increase as the numbers 1, 2, 3, . . . &c.

By taking several pendulums of exactly equal length, B, C, D (fig. 65), but with spheres of different substances—lead, copper, ivory—it is found that, neglecting the resistance of the air, these pendulums oscillate in equal times, thereby showing that the accelerative effect of gravity on all bodies is the same at the same place.

By means of an arrangement resembling the above, Newton verified the fact that the *masses* of bodies are determined by the balance ; which, it will be remarked, lies at the foundation of the measure of force. For it will be seen on comparing 56 and 57 with 51 that the law of the periodic time is obtained on the supposition that the force of gravity on all bodies is represented by Mg , in which M is determined by the balance. In order to verify this, he had two equal cylindrical wooden boxes made ; one he

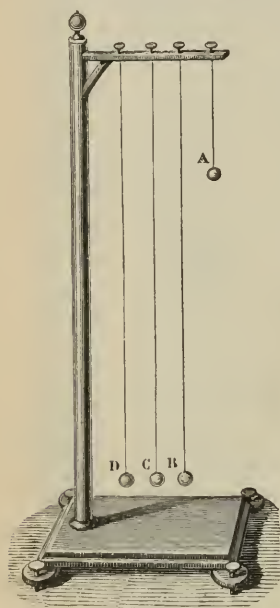

Fig. 65

filled with wood, and as nearly as possible in the centre of oscillation of the other he placed an equal weight of gold. He then suspended the boxes by threads eleven feet long, so that they formed pendulums exactly equal so far as weight, figure, and resistance of the air were concerned. Their oscillations were performed in exactly the same time. The same results were obtained when other substances were used, such as silver, lead, glass, sand, salt, wood, water, corn. Now all these bodies had equal weights, and being contained in the same boxes, they experienced the same resistance by the

air, and if the inference that therefore they had equal masses had been erroneous, by as little as the one-thousandth part of the whole, the experiment would have detected it.

83. **Application of the pendulum to clocks.**—The regulation of the motion of clocks is effected by means of pendulums, that of watches by *balance-springs*. Pendulums were first applied to this purpose by Huyghens in 1658, and in the same year Hooke applied a spiral spring to the balance of a watch. The manner of employing the pendulum is shown in fig. 66. The pendulum rod passing between the prongs of a fork, *a*, communicates its motion to a rod, *b*, which oscillates on a horizontal axis, *o*. To this axis is fixed a piece, *mn*, called an *escapement* or *crutch*, terminated by two projections or *pallets*, which work alternately with the teeth of the *escapement wheel* R. This wheel being acted on by the driving weight tends to move continuously, let us say, in the direction indicated by the arrow-head. Now, if the pendulum is at rest, the wheel is held at rest by the pallet *m*, and with it the whole of the clockwork and the weight. If, however, the pendulum moves and takes the position shown by the dotted line, *m* is raised, the wheel *escapes* from the confinement in which it was held by the pallet, the weight descends, and causes the wheel to turn until its motion is arrested by the other pallet *n*; which, in consequence of the motion of the pendulum, will be brought into contact with another tooth of the escapement wheel. In this manner the descent of the weight is alternately permitted and arrested—or, in a word, *regulated*—by the pendulum. By means of a proper train of wheelwork the motion of the escapement is communicated to the hands of the clock; and consequently their motion, also, is regulated by the pendulum. In watches the watch-spring plays the part of the weight in clocks.

The pendulum has also been used for measuring great velocities. A large wooden box filled with sand and weighing from 3 to 5 tons is coated with iron and suitably suspended; against this arrangement, which is known as a *ballistic pendulum*, a shot is fired, and the deflection thereby produced is observed. From the laws of the impact of inelastic bodies, and from those of the pendulum, the velocity of the ball may be calculated from the amount of this deflection.

The gun may also be fastened to a pendulum arrangement; and, when fired, the reaction causes an angular deflection, from which the initial velocity of the shot can be deduced.

An interesting application of the pendulum is to the *metronome*, which consists of a short rod with a fixed bob; on the rod and above the axis is a sliding weight. By raising this the period of the pendulum is increased; by lowering it diminished; and thus even with a short pendulum the beats can be made pretty long. Maelzel connected this with a clockwork arrangement so that the beats are quite audible.

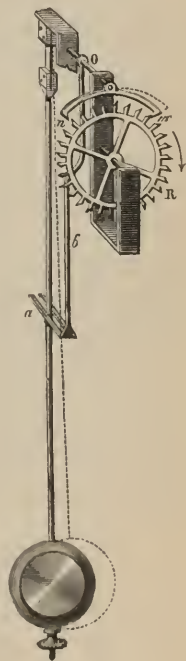

Fig. 66

84. **Causes which modify the intensity of terrestrial gravitation.**—The intensity of the force of gravity—that is, the value of g —is not the same in all parts of the earth. It is modified by several causes, of which the form of the earth and its rotation are the most important.

i. The attraction which the earth exerts upon a body at its surface is the sum of the partial attractions which each part of the earth exerts upon that body, and the resultant of all these attractions may be considered to act from a single point—the centre; that is, the whole mass of the earth may be supposed to be concentrated at its centre. Hence, if the earth were a perfect sphere, a given body would be equally attracted at any part of the earth's surface. The attraction would, however, vary with the height above the surface. For small alterations of level the differences would be inappreciable; but for greater heights and in accurate measurements observations of the value of g must be reduced to the sea-level. The attraction of gravitation being inversely as the square of the distance from the centre (68), we shall have

$g : g_i = \frac{1}{R^2} : \frac{1}{(R+h)^2}$ where g is the value of the acceleration of gravity at the sea-level, g_i its value at any height h , and R is the radius of the earth. From this, seeing that h is very small compared with R , and that therefore its square may be neglected in comparison with R^2 , we get by simple algebraical transformation $g_i = \frac{R^2}{(R+h)^2} = \frac{R}{R+2h}$

But even at the sea-level the force of gravity varies in different places in consequence of the form of the earth. The earth is not a true sphere, but an ellipsoid, the major axis of which is 12,754,796 metres, and the minor 12,712,160 metres. The distance, therefore, from the centre being greater at the Equator than at the Poles, and the attraction on a body being inversely as the square of these distances, calculation shows that, due to this cause, the attraction is $\frac{1}{575}$ greater at the Poles than at the Equator. This is what would be true if, other things being the same, the earth were at rest.

ii. In consequence of the earth's rotation, the force of gravity is further modified. A body relatively at rest on the Equator shares the earth's rotation, and describes, in the course of one day, a circle, whose centre and radius are the centre and radius of the earth. Now, since a body in motion tends by reason of its inertia to move in a straight line, it follows that to make it move in a circle, a force must be employed at each instant to deflect it from the tangent (55). Consequently, a certain portion of the earth's attraction must be employed in keeping the above body on the surface of the earth, and only the remainder is sensible as *weight*. It appears from calculation that at the Equator the $\frac{1}{2875}$ th part of the earth's attraction on any body is thus employed, so that the magnitude of g at the Equator is less by the $\frac{1}{2875}$ th part of what it would be were the earth at rest.

iii. As the body goes nearer the Poles the force of gravity is less and less diminished by the effect of centrifugal force. For in any given latitude it will describe a circle coinciding with the parallel of latitude in which it is placed; but as the radii of

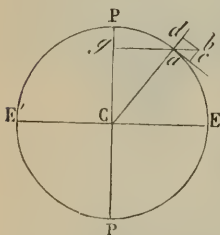

Fig. 67

these circles diminish, so does the centrifugal force up to the Pole, where the radius is null. Further, on the Equator the centrifugal force is directly opposed to gravitation : in any other latitude only a component of the whole force is thus employed. This is seen in fig. 67, in which PP' represents the axis of rotation of the earth, and EE' the Equator. At any given point E on the Equator the centrifugal force is directed along CE , and acts wholly in diminishing the intensity of gravitation ; but on any other point, a , nearer the Pole, the centrifugal force acting in a right line ab at right angles to the axis PP' , while gravity acts along aC , gravity is no longer diminished by the whole of the centrifugal force, but only by its component ad , which is less the nearer a is to the Pole.

The combined effect of these two causes—the flattening of the earth at the Poles, and the centrifugal force—is to make the attraction of gravitation at the Equator less by about the $\frac{1}{192}$ nd part of its value at the Poles.

CHAPTER III

PROPERTIES PECULIAR TO SOLIDS

85. **Various special properties.**—After having described the principal properties common to solids, liquids, and gases, we shall discuss the properties peculiar to solids. They are *elasticity*, *tenacity*, *ductility*, and *hardness*. With regard to elasticity we must distinguish between *elasticity of volume*, *longitudinal elasticity*, and *torsional elasticity* or *simple rigidity*.

When force is applied to a solid body the shape or the volume of the latter is changed. The force per unit area which produces this change is called the applied *stress*, and the change itself is spoken of as a *strain*. Thus stress produces strain. If the displacements of the molecules of a body due to the action of stress are small, the strains produced are proportional to the stresses producing them, and hence the ratio $\frac{\text{stress}}{\text{strain}}$ is constant and is called the *coefficient of elasticity* of the body, this coefficient being greatest in those cases where a small displacement requires a very large force to produce it. Thus, steel and glass are highly elastic bodies because in them the application of even a large force will produce only a small change of shape or volume. For by *force of elasticity* is understood the force with which the displaced particles tend to revert to their original position, and this force is equivalent to that which has brought about the change. Considered from this point of view, gases have the least force of elasticity; that of liquids is considerably greater, and is, indeed, greater than that of many solids. Thus the force of elasticity of mercury is greater than that of india rubber, wood, and stone. It is, however, less than that of the other metals.

This mode of defining elasticity differs somewhat from ordinary ideas according to which bodies, such as india rubber, are considered highly elastic which undergo considerable change of form on the application of a small force. A body is perfectly elastic when any given stress produces no permanent set, restitution being always complete. It is imperfectly elastic when it does retain permanently such a set. Within the limits of elasticity all bodies may be regarded as perfectly elastic.

86. **Volume elasticity.**—Elasticity of volume is the only kind of elasticity a liquid or a gas possesses, for liquids and gases have no definite shape. A solid may by the application of stress have not only its volume but also its shape altered. The volume elasticity of a body is measured, as we have said, by the ratio stress/strain. The stress is the force per unit area uniformly applied to the body to compress it; the strain is the resulting compression, that is, the ratio of the change of volume to the original volume. If the

original volume V is reduced to $V - v$ when the stress upon it is increased by an amount p , the strain is v/V , and

$$\text{Coefficient of volume elasticity} = \frac{p}{\frac{v}{V}} = \frac{pV}{v} = k.$$

The dimensions (63) of p are those of a force divided by an area, *i.e.* $\frac{ML}{T^2}/L^2$ or M/LT^2 . Since the strain is the ratio of a volume to a volume, its dimensions are zero. Thus the dimensions of k , the coefficient of volume elasticity, are the same as those of a pressure.

The reciprocal of k is called the coefficient of compressibility or simply the compressibility of the body.

In the following table the volume-elasticities of some solids are given, and of a few liquids for comparison. The units are C.G.S.

Substance	k = volume elasticity	$\frac{1}{k}$ = compressibility
Wrought iron	14.56×10^{11}	$.069 \times 10^{-11}$
Cast iron	9.64×10^{11}	$.103 \times 10^{-11}$
Steel	18.4×10^{11}	$.054 \times 10^{-11}$
Glass	4.0×10^{11}	$.250 \times 10^{-11}$
Copper	16.8×10^{11}	$.060 \times 10^{-11}$
Water	$.22 \times 10^{11}$	4.55×10^{-11}
Mercury	2.60×10^{11}	$.38 \times 10^{-11}$
Alcohol	$.14 \times 10^{11}$	7.14×10^{-11}

87. **Longitudinal elasticity.**—If a wire is clamped securely at its upper end, and a weight is attached to its lower end, the wire becomes longer, and, provided the limits of elasticity are not overstepped, the elongation is directly proportional to the stretching force; and for wires of the same material but of different diameters, the elongation is inversely proportional to the cross section, the stretching force being constant. These results have been established by experiment with apparatus such as that represented in fig. 68. At the lower end of the wire AB there is a scale-pan, and on the wire two points A and B are marked, the distance between which is measured by means of the *catetometer*.

The catetometer consists of a strong upright brass support, K, with a scale divided into millimetres, which can be adjusted in an exactly vertical position by means of levelling screws and the plumb-line. A small telescope, exactly at right angles to the scale, can be moved up and down, and is provided with a vernier which measures fiftieths of a millimetre. By adjusting the telescope successively on the two points A and B, as represented in the figure, the distance between these points is obtained on the graduated scale. By measuring AB before and after the load has been increased by an amount W, the elongation is obtained.

By experiments of this kind it has been ascertained that—

The alteration in length within the limits of elasticity is in proportion to the length and to the load acting on the body, and is inversely as the cross section

Let r be the radius of the wire, l its length, and e the elongation produced by the application of a load W . The stress, or force per unit of cross section of the wire, is $Wg/\pi r^2$, and since the length l is stretched by an amount e , the strain is e/l . Thus by the definition,

$$\text{Coefficient of longitudinal elasticity, or Young's modulus} \left\{ \mu = \frac{Wg}{\pi r^2} = \frac{Wgl}{\pi r^2 e} \right.$$

We see from this expression that if the wire has unit cross section ($\pi r^2 = 1$) and is stretched to double its length ($e = l$), $\mu = W$. In other words, we may define Young's modulus as the stretching force which must be applied to a wire of unit cross section to double its length. This cannot be directly observed, for no substance has elastic limits so wide as to undergo stretching to double its length without permanent set; μ , however, may be calculated from any accurate observations by means of the above formula.

In the following table the values of μ are given in C.G.S. units:—

Substance	Longitudinal Elasticity = μ	Substance	Longitudinal Elasticity = μ
Wrought iron	21.2×10^{11}	Rock salt	4.31×10^{11}
Steel	19.2×10^{11}	Marble	2.35×10^{11}
Platinum	17.4×10^{11}	Lead	1.84×10^{11}
Copper	12.75×10^{11}	Pine	1.13×10^{11}
Slate	11.25×10^{11}	Oak	$.94 \times 10^{11}$
Zinc	8.9×10^{11}	Whalebone	$.71 \times 10^{11}$
Brass	8.7×10^{11}	Ice	$.66 \times 10^{11}$
Crown glass	8.1×10^{11}	Sandstone	$.64 \times 10^{11}$

As an example, suppose we wish to determine the length of copper wire 1 sq. mm. in cross section which would be stretched 2 mm. by a weight of 10 kilogr. Here $Wg = 10 \times 1000 \times 981$ dynes, $e = .2$ cm., $\pi r^2 = .01$ sq. cm., and $\mu = 12.75 \times 10^{11}$; hence, from the formula,

$$12.75 \times 10^{11} = \frac{10^1 \times 981 \times l}{.01 \times .2}, \text{ and } l = 259.5 \text{ cm.}$$

The limit of elasticity is given by the smallest force necessary to produce appreciable permanent elongation in a wire of unit cross section.

Longitudinal stretching is accompanied by a lateral contraction, and the ratio of the contraction to the stretching is known as *Poisson's coefficient*. Let S be the section of the wire, and s the diminution of section due to stretching; then the *contraction* = $\frac{s}{S}$. Also, if L is the original, and l the

increase of, length, $\frac{l}{L}$ = the stretching. *Poisson's ratio* = $\frac{s}{S} \div \frac{l}{L} = \frac{Ls}{Sl}$. The numerator of this fraction is the change of volume due to contraction, the length being constant, and the denominator is the change of volume due to

stretching, the section being constant. This ratio was taken by Poisson to be 0.25, but later experiments have found it to vary from 0 to 0.5; it is about 0.25 for glass, and nearly 0.5 for india rubber. When a wire is stretched by a load to within the limit of elasticity, some time often elapses before the full effect is produced, and conversely when the load is removed the wire does not at once wholly resume its original condition, but a small portion of the deformation remains, and it only reverts to its initial state after the lapse of some time. This phenomenon, first observed by Weber, which is met with in most elastic changes of form, is called the *elastic after-action or effect*, or the *elastic fatigue*. This phenomenon is probably due to the fact that the molecules of bodies are not spherical, but are variously extended in different directions, and in elastic deformation are not only displaced in reference to each other, but are also twisted.

This may be illustrated by the following experiment. A piece of india-rubber tube is closed by a glass plug at the bottom, while the open end is passed over a piece of glass tube. Coloured liquid is then poured in so that it stands at a certain height in this tube. If then a weight is suspended to the lower end of the

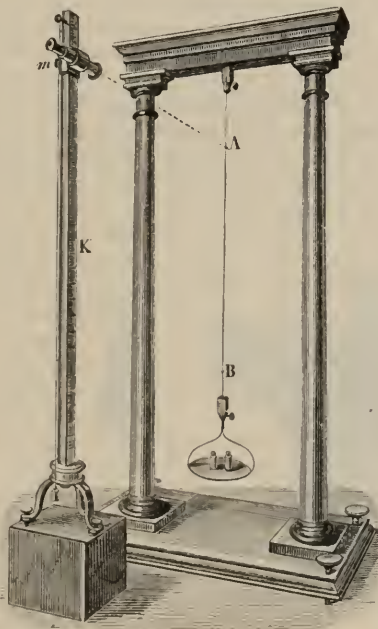

Fig. 68

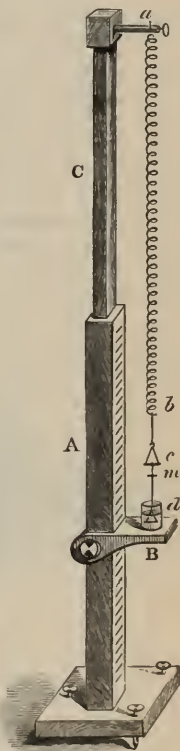

Fig. 69

india-rubber tube, the liquid at once sinks to a considerable distance and afterwards very slowly a little further. On removing the weight it rises again, but not immediately to the old height. This it only reaches after some time. Both calculation and experiment show that when bodies are lengthened by traction their volume increases.

When weights are placed on a bar, the amount by which it is shortened, or the *coefficient of contraction*, is equal to the elongation which it would experience if the same weights were suspended to it, and is represented by the above numbers.

The influence of temperature on the elasticity of iron, copper, and brass was investigated by Kohlrausch and Loomis. They found that the alteration in the coefficient of elasticity by heat is the same as that which heat produces in the coefficient of expansion and in the refractive power; it is also much the same as the change in the permanent magnetism, and in the specific heat, while it is less than the alteration in the conductivity for electricity.

As an application of elasticity may be mentioned Jolly's *spring balance*. This consists of a long steel wire, *ab* (fig. 69), wound in the form of a spiral, which is suspended in front of an accurately graduated scale. To the lower end of the spiral two scale-pans, *c* and *d*, are hung by a thread, the lower one, *d*, dipping in a small vessel of water on an adjustable support. The instrument is graduated empirically by observing what displacement of the mark *m* is produced by putting a known weight in the scale-pan *c*. Knowing then once for all the constant of the instrument, it is easy to determine the weight of a body by reading the displacement which it produces along the scale.

88. **Determination of Young's modulus by flexure.**—A solid, when cut into a rod or thin plate, and fixed at one end, after having been more or less bent, strives to return to its original position when left to itself. This property is known as the *elasticity of flexure*, and is very marked in steel, india rubber, wood, and paper.

If a rectangular bar AB is clamped at one end and loaded at the other

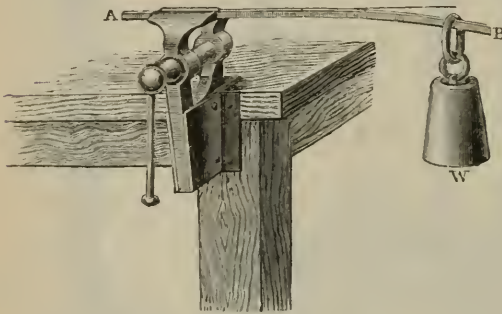

Fig. 70

end by a weight *W* (fig. 70), a flexure will be produced which may be observed by the cathetometer. The elasticity involved here is of the same kind as that investigated above, viz. longitudinal elasticity, the coefficient of which is Young's modulus; for, as the bar is bent, its upper parts are elongated while the lower parts are compressed. If the amount of this flexure

is denoted by λ , Young's modulus is given by the formula

$$\mu = \frac{4Wgl^3k}{bh^3\lambda},$$

where *W* is the load, *l* the length of the bar, *b* its breadth, *h* its depth or thickness, and *k* a constant, which depends on the manner in which the rod is supported, the three principal cases being represented in fig. 71; α is that in which the rod is supported at one end, as in fig. 70; in β the rod rests on knife-edges, with both ends free; while in γ both ends are rigid; if one and the same bar is fastened in these different ways, the values of λ are respectively 1, $\frac{1}{6}$, $\frac{1}{4}$.

It will thus be seen that if for a given load the depression is not to be greater with a long beam than with a short one, the vertical thickness must increase in the same ratio as the length.

The elasticity of flexure is applied in a vast variety of instances—for example, in bows, watch-springs, carriage-springs; in spring balances it is used to determine weights, in dynamometers to determine the force of agents in prime movers; and, as a property of wool, hair, and feathers, it is applied to domestic uses in cushions and mattresses.

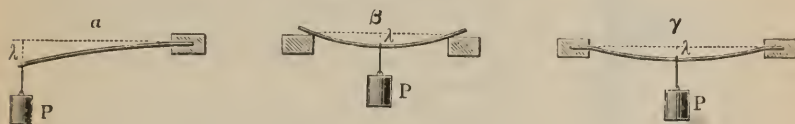

Fig. 71

Whatever be the kind of elasticity, there is, as has been already said (85), a limit to it—that is, there is a molecular displacement beyond which bodies are broken, or at any rate do not regain their primitive form. This limit is affected by various causes. The elasticity of many metals is increased by *hardening*, whether by cold, by means of the draw-plate, by rolling, or by hammering. Some substances, such as steel, cast iron, and glass, become both harder and more elastic by tempering (93).

Elasticity, on the other hand, is diminished by *annealing*, which consists in raising the body to a temperature lower than that necessary for tempering, and allowing it to cool slowly. By this means the elasticity of springs may be regulated at pleasure. Glass, when it is heated, undergoes a true tempering in being rapidly cooled, and hence, in order to lessen the fragility of glass objects, they are reheated in a furnace, and are carefully allowed to cool slowly, so that the particles have time to assume their most stable position (93).

89. **Elasticity of torsion. Simple rigidity.**—The laws of the torsion of wires were determined by Coulomb, by means of an apparatus called the *torsion balance* (fig. 72). It consists essentially of a metal wire, clamped at one end in a support, A, and holding at the other a metal sphere, B, to which is affixed a light index. Immediately below this there is a graduated circle, CD. If the sphere is rotated through a certain angle indicated by the position of the index on the scale, which is the *angle of torsion*, the twisting couple necessary to produce this effect is called the *moment of torsion*. When, after this deflection, the sphere is left to itself, the reaction of torsion produces its effect, the wire untwists itself, and the sphere rotates about its vertical axis with increasing rapidity until it reaches its position of equilibrium. It does not, however, rest there: in virtue of its inertia it passes this position, and the wire undergoes a torsion in the opposite direction. The equilibrium being destroyed, the wire tends to untwist itself, the same alterations are again produced, and the needle does not rest at zero of the scale until after a certain number of oscillations about this point have been completed. Such an arrangement is sometimes called a *torsion pendulum*.

By means of this apparatus Coulomb found that when the amplitude of

the oscillations is within certain limits, the oscillations are represented by the following laws :

- I. *The oscillations are very nearly isochronous.*
- II. *For the same wire, the angle of torsion is proportional to the moment of torsion.*
- III. *With the same moment of torsion, and with wires of the same diameter, the angles of torsion are proportional to the length of the wires.*

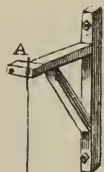

Fig. 72

- IV. *The same moment of torsion being applied to wires of the same length, the angles of torsion are inversely proportional to the fourth powers of the diameters.*

Wertheim examined the elasticity of torsion in the case of stout rods by means of a different apparatus, and found that it is also subject to these laws. He further found that, all dimensions being the same, different substances undergo different degrees of torsion for the same force, and each substance has its own coefficient of torsion, which is usually denoted by n . The value of this coefficient is about $\frac{1}{3}$ that of the longitudinal modulus of elasticity.

The laws of torsion may be enunciated in the formula $\omega = \frac{2F}{nr^4}$; in which ω is the angle of torsion, F the moment of the force of torsion—*i.e.* the applied deflecting couple— l the length of the wire,

r its radius, and n the *torsion-coefficient* or *simple rigidity*.

As the angle of torsion is inversely proportional to the fourth power of the radius, rods of some thickness require very great force to produce even small twists. With very small diameters, such as those of a cocoon or glass thread, the proportionality between the angle of torsion and the twisting couple holds even for several complete turns.

We may here mention a very ingenious method of obtaining very fine threads of glass, and even of quartz and other minerals, which has been devised by Professor Boys. It consists in attaching a stout thread of the substance in question to a small arrow of straw, melting the end so as to form a small drop. When the arrow is shot from a small crossbow, the drop remains behind in virtue of its inertia (19), and a thread practically uniform but of excessive tenuity is spun out from it and carried along with the arrow. In this way glass threads 90 feet in length and $\frac{1}{10000}$ th of an inch in diameter have been produced. By the same method, melting quartz with the oxy-hydrogen blowpipe, threads of this substance have been produced which are not more than 0.00001 inch in diameter. Such threads are of great value in torsion experiments, for, while they possess great tenacity, they are almost destitute of the property of *elastic fatigue* (87).

89A. **Moment of inertia.**—The time of vibration of any oscillating system depends not only upon the mass of the system, but also upon the distribution of the mass about the axis of vibration. A body will clearly vibrate more

slowly as its mass is farther removed from the axis of vibration. The periodic time of a vibrating system is given by the equation

$$t = 2\pi \sqrt{\frac{\text{moment of inertia}}{\text{moment of forces producing vibration}}} = 2\pi \sqrt{\frac{I}{FL}}$$

F being the acting force, L the arm at which it acts, and I the moment of inertia.

The *moment of inertia* of a body in vibration is defined as the sum of the products of the mass of each particle of the body into the square of its distance from the axis of oscillation, and is expressed as mk^2 , where m is the mass of the body and k its *radius of gyration*. In the case of bodies of regular shape the value of k may be determined by the integral calculus, and hence we can by experimental methods determine k for bodies of irregular shape.

For a simple pendulum (56) it is evident that the moment of inertia is ml^2 , where m is the mass of the bob, and l its distance from the point of suspension—*i.e.* the length of the string; also $FL = mg \cdot l$,

$$\therefore t = 2\pi \sqrt{\frac{ml^2}{mgl}} = 2\pi \sqrt{\frac{l}{g}}$$

the formula already used.

The moment of inertia of a cylindrical rod of length l , and radius r , oscillating about an axis through its middle point and perpendicular to its length, is

$$m \left(\frac{l^2}{12} + \frac{r^2}{4} \right)$$

that of a rectangular bar (length = l , breadth = b), the axis of oscillation being perpendicular to the face bl , and passing through its middle point, is

$$m \frac{l^2 + b^2}{12}$$

90. **Tenacity.**—*Tenacity* is the resistance which a body opposes to the total separation of its parts. According to the manner in which the external force acts, we may have various kinds of tenacity: *tenacity* in the ordinary sense, or resistance to traction; *relative tenacity*, or resistance to fracture; *reactive tenacity*, or resistance to crushing; *sheering tenacity*, or resistance to displacement of particles in a lateral direction; and *torsional tenacity*, or resistance to twisting. Ordinary tenacity is determined in different bodies by forming them into cylindrical or prismatic wires, and ascertaining the weight necessary to break them.

Mere increase in length does not influence the breaking weight, for the weight acts in the direction of the length, and stretches all parts as if it had been directly applied to them.

Tenacity is directly proportional to the breaking weight, and inversely proportional to the area of a transverse section of the wire.

Tenacity diminishes with the duration of the traction. A small force continuously applied for a long time will often break a wire, which would not at once be broken by a larger weight.

Not only does tenacity vary with different substances, but it also varies with the form of the body. Thus, with the same sectional area, a cylinder has greater tenacity than a prism. The quantity of matter being the same, a hollow cylinder has greater tenacity than a solid one; and the tenacity of this hollow cylinder is greatest when the external radius is to the internal one in the ratio of 11 to 5. The shape has also the same influence on the resistance to crushing as it has on the resistance to traction. A hollow cylinder with the same mass, and the same weight, offers a greater resistance than a solid cylinder. Thus it is that the bones of animals, the feathers of birds, the stems of corn and other plants, offer greater resistance than if they were solid, the mass remaining the same.

Tenacity, like elasticity, is not the same in all directions in bodies. In wood, for example, both the tenacity and the elasticity are greater in the direction of the fibres than in a transverse direction. And this difference obtains in general in all bodies the texture of which is not uniform.

Wires by being worked acquire greater tenacity on the surface, and have therefore a higher coefficient than even somewhat thicker rods of the same material; and, according to some physicists, solids have a *surface tension* analogous to that of liquids (133). A strand of wires is stronger than a rod whose section is equal to the sum of the sections of the wires.

Wertheim found the following numbers representing the weight in kilogrammes for the limit of elasticity, and for the tenacity of wires, 1 mm. in diameter.

		Limit of Elasticity. Kilogrammes	Tenacity, Kilogrammes
Lead . . .	{ drawn . . .	0·25	2·07
	{ annealed . . .	0·20	1·80
Tin . . .	{ drawn . . .	0·45	2·45
	{ annealed . . .	0·20	1·70
Silver	{ drawn . . .	11·25	29·00
	{ annealed . . .	2·75	16·02
Copper . . .	{ drawn . . .	12·00	40·30
	{ annealed . . .	3·00	30·54
Platinum . . .	{ drawn . . .	26·00	34·10
	{ annealed . . .	14·50	23·50
Iron . . .	{ drawn . . .	32·50	61·10
	{ annealed . . .	5·00	46·88
Steel . . .	{ drawn . . .	42·50	70·00
	{ annealed . . .	15·00	40·00
Cast Steel . . .	{ drawn . . .	55·60	80·00
	{ annealed . . .	5·00	65·75

The table shows that of all metals cast steel has the greatest tenacity. Yet it is exceeded by fibres of unspun silk, a thread of which 1 square millimetre in section can carry a load of 500 kilogrammes. Single fibres of cotton can support a weight of 100 to 300 grammes; that is, millions of times their own weight. The tenacity of glass is greatly affected by its chemical composition, varying from 3·5 to 11·9 kilogrammes per square millimetre.

In this table the bodies are supposed to be at the ordinary temperature. At higher temperatures the tenacity rapidly decreases. Seguin made some

experiments on this point with iron and copper, and obtained the following values for the tenacity, in kilogrammes, of millimetre wire at different temperatures :—

Iron	.	.	at 10°, 60; at 370°, 54; at 500°, 37
Copper	.	„	„ 21; „ 7·7; „ 0

On the other hand, the tenacity is greatly increased at low temperatures : thus Dewar found that at -182° C. the breaking stress of iron is twice as great as at the normal temperature, and other metals and alloys are all increased by one-third to one-half the normal amount.

91. **Ductility.**—*Ductility* is the property in virtue of which a great number of bodies change their forms by the action of traction or pressure.

With certain bodies, such as clay, wax, &c., the application of a very little force is sufficient to produce a change ; with others, such as the resins and glass, the aid of heat is needed ; while with the metals more powerful agents must be used, such as percussion, the draw-plate, or the rolling-mill.

Malleability is that modification of ductility which is exhibited by hammering. The most malleable metal is gold, which has been beaten into leaves about the $\frac{1}{300000}$ th of an inch thick.

The most ductile metal is platinum. Wollaston obtained a wire of it 0·00003 of an inch in diameter. This he effected by covering with silver a platinum wire 0·01 of an inch in diameter, so as to obtain a cylinder 0·2 inch in diameter only, the axis of which was of platinum. This was then drawn out in the form of wire as fine as possible : the two metals were equally extended. When this wire was afterwards boiled with dilute nitric acid the silver was dissolved, and the platinum wire left intact. The wire was so fine that a mile of it would have weighed only 1·25 of a grain.

The glass threads drawn by Professor Boys' method (89) are so fine, being under the $\frac{1}{100000}$ th of an inch, that a mile would not weigh more than one-third of a grain. Such threads of quartz have a tenacity approaching that of steel wire.

92. **Hardness.**—*Hardness* is the resistance which bodies offer to being scratched or worn by others. It is only a relative property, for a body which is hard in reference to one body may be soft in reference to others. The relative hardness of two bodies is ascertained by trying which of them will scratch the other. Diamond is the hardest of all bodies, for it scratches all, and is not scratched by any. The hardness of a body is expressed by referring it to a *scale of hardness* : that usually adopted is—

- | | | |
|--------------|------------|-------------|
| 1. Talc | 5. Apatite | 8. Topaz |
| 2. Rock Salt | 6. Felspar | 9. Corundum |
| 3. Calcspars | 7. Quartz | 10. Diamond |
| 4. Fluorspar | | |

Thus, the hardness of a body which would scratch felspar, but would be scratched by quartz, would be expressed by the number 6·5.

Huegenay determined the weight necessary to force a steel point to a depth of 10 mm., and found the order of the metals in increasing hardness as follows : lead, tin, aluminium, gold, silver, platinum, zinc, copper, iron, steel.

The pure metals are softer than their alloys. Hence it is that, for jewelry and coinage, gold and silver are alloyed with copper to increase their hardness.

The hardness of a body has no relation to its resistance to compression. Glass and diamond are much harder than wood, but the latter offers far greater resistance to the blow of a hammer. Hard bodies are often used for polishing powders; for example, emery, pumice, and tripoli. Diamond, being the hardest of all bodies, can only be ground by means of its own powder.

A body which moves with great velocity can cut into bodies which are harder than itself. Thus a disc of wrought iron rotating with a peripheral velocity of 11 metres per second was cut by a steel graver; while when it rotated with a velocity of 20 metres, the edge of the disc could cut the graver, and with a velocity of 50 to 100 metres it could even cut into agate and quartz.

A *brittle* body is one in which the connection between the parts is destroyed by the application of a small force. Arsenic, bismuth, and heated zinc are examples of brittle metals; they are easily reduced to powder. Brittleness or fragility depends on the fact that bodies possessing it do not allow the molecules to be displaced in reference to each other, but rather the molecules become detached.

93. **Temper.**—By sudden cooling after they have been raised to a high temperature, many bodies, more especially steel, become hard and brittle. By reheating and cooling slowly, a process which is called *annealing*, hard and brittle steel may be converted into a soft, flexible material, and in general, by varying the limits of temperature within which the change takes place, almost any degree of elasticity and flexibility may be given to it. This operation is called *tempering*. All cutting instruments are made of tempered steel. There are, however, some few bodies upon which tempering produces quite a contrary effect. An alloy of one part of tin and four parts of copper, called *tantam metal*, is ductile and malleable when rapidly cooled, but hard and brittle as glass when cooled slowly. Manganese steel, an alloy of manganese and iron containing about 13 per cent. of manganese, becomes more ductile when raised to a high temperature and quenched in cold water. When annealed in the ordinary way it is hard and brittle.

BOOK III

ON LIQUIDS

CHAPTER I

HYDROSTATICS

94. **Province of hydrostatics.**—The science of *hydrostatics* treats of the conditions of the equilibrium of liquids, and of the pressures they exert, whether within their own mass or on the sides of the vessels in which they are contained.

95. **General characters of liquids.**—It has been already seen (4) that liquids are bodies whose molecules are displaced by the slightest force. Their fluidity, however, is not perfect; their particles always adhere slightly to each other, and when a thread of liquid moves, it attempts to drag the adjacent stationary particles with it, and conversely is held back by them. This property is called *viscosity* (147), and bodies which possess this property in a high degree are said to be *viscous*.

Gases also possess fluidity, but in a higher degree than liquids. The distinction between the two forms of matter is that liquids are only slightly compressible and are comparatively inexpandible, while gases are eminently compressible and expand spontaneously.

The fluidity of liquids is seen in the readiness with which they take all sorts of shapes. Their compressibility is established by the following experiment.

96. **Compressibility of liquids.**—From the experiment of the Florentine Academicians (13), liquids were for a long time regarded as being completely incompressible. Since then researches have been made on this subject by various physicists, which have shown that liquids are really compressible.

The apparatus used for measuring the compressibility of liquids has been named the *piezometer* (πιέζω, I compress; μέτρον, measure). That shown in fig. 73 consists of a strong glass cylinder with very thick sides, and an internal diameter of about $3\frac{1}{4}$ inches. The base of the cylinder is firmly cemented into a wooden foot, and on its upper part is fitted a metal cylinder closed by a cap which can be unscrewed. In this cap there is a funnel, R, for introducing water into the cylinder, and a small barrel hermetically closed by a piston, which is moved by a screw, P.

In the inside of the apparatus there is a glass vessel, A, containing the

liquid to be compressed. The upper part of this vessel terminates in a capillary tube, which dips under mercury, O. This tube has been previously divided into parts of equal capacity, and it has been determined how many of these parts the vessel A contains. The latter is ascertained by finding the weight, P, of the mercury which the reservoir A contains, and the weight, p , of the mercury contained in a certain number of divisions, n , of the capillary tube. If N is the number of divisions of the small tube contained in the whole reservoir, we have $\frac{N}{n} = \frac{P}{p}$, from which

the value of N is obtained. There is further a *manometer*. This is a glass tube, B, containing air, closed at one end, the other end of which dips under mercury. When there is no pressure on the water in the cylinder, the tube B is completely full of air; but when the water within the cylinder is compressed by means of the screw P, the pressure is transmitted to the mercury, which rises in the tube, compressing the air which it contains. A graduated scale fixed on the side of the tube shows the reduction of volume, and this reduction of volume indicates the pressure exerted on the liquid in the cylinder, as will be seen later (184).

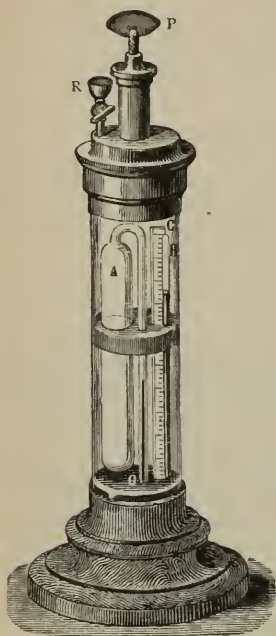

Fig. 73

In making the experiment, the vessel A is filled with the liquid to be compressed, and the end dipped under the mercury. By means of the funnel R the cylinder is entirely filled with water. The screw P being then turned, the piston moves downwards, and the pressure exerted upon the water is transmitted to the mercury and the air; in consequence of which the mercury rises in the tube B, and also in the capillary tube. The ascent of mercury in the capillary tube shows that the liquid in the vessel A has diminished in volume, and gives the amount of its compression, for the capacity of the whole vessel A in terms of the graduated divisions on the capillary tube has been previously determined.

In his first experiments, Oersted assumed that the capacity of the vessel A remained the same, its sides being compressed both internally and externally by the liquid. But this capacity diminishes in consequence of the external and internal pressures. Colladon and Sturm made some experiments allowing for this change of capacity, and found that for a pressure equal to that of the atmosphere, mercury experiences a compression of $0.0038 (= 3.8 \times 10^{-6})$ part of its original volume, water a compression of 50×10^{-6} , and ether a compression of 113×10^{-6} part of its original bulk. The compressibility of sea water is only about 44×10^{-6} : it is not materially denser even at great depths; thus at the depth of a mile its density would be only about $\frac{1}{130}$ the greater. Röntgen and Schneider showed that the compressibility of aqueous solutions is less than that of pure water.

Amagat has investigated the compressibility of liquids within very wide limits of pressure and temperature. Fig. 74 represents an apparatus by which he worked from 0° to 50° and up to pressures exceeding 3000 atmospheres. The glass cylinder in Oersted's experiment is replaced by one of steel, GG'G', 18 cm. in diameter and 120 cm. long. It is surrounded by a jacket, HH, which can either be filled with ice, or through which a current of water of uniform temperature can be passed. The liquid is contained in a glass piezometer, the bottom of which dips in a cup of mercury, the whole being placed in the mercury in the cylinder GG'G'. When pressure is applied the mercury rises in the stem, and touches successively a series of fine platinum wires fused in the stem and connected with an insulated wire which passes from the apparatus through I'; the arrangement is such that when the liquid is compressed the mercury rising comes in contact with the wire and completes a galvanic circuit (Book X), the existence of which is shown by a galvanometer. The pressure is produced at first by a pump which injects water through the tap E; beyond a certain pressure this is closed, and the pressure continued by the arrangement screwed in the top of the apparatus. In this a steel cylinder P, driven by a screw V, worked by a lever T, pushes before it a leather collar C shown on the side.

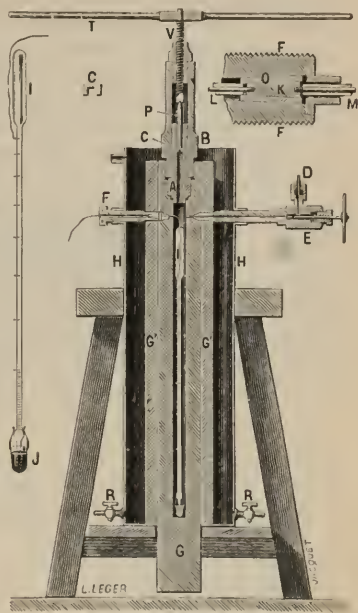

Fig. 74

The pressure was measured by means of a manometer let in at the side on the same level as the pieces E and F, which could not be shown in the figure.

The results which Amagat attained by this apparatus show that the coefficient of compressibility of liquids diminishes as the pressure increases; this diminution is more marked the higher the temperature, but the rate of diminution is less at higher pressures.

The coefficient of the compressibility, except in the case of water, increases with the temperature; the increase is more rapid the higher the temperature and is less so as the pressures are higher.

All the results are corrected for the compressibility of glass, which was found to be 0.00222 per atmosphere; particular attention was paid to the determination of the coefficient for mercury, which was found to be 0.0039 .

Whatever be the pressure to which a liquid has been subjected, experiment shows that as soon as the pressure is removed the liquid regains its original volume, from which it is concluded that liquids are perfectly elastic.

Liquids may be *stretched* as well as compressed. Worthington showed that the volume-elasticity of alcohol is the same for extension as for

compression within wide limits of pressure. Ether is more, and water less, extensible than alcohol.

97. **Equality of pressures. Pascal's law.**—By considering liquids as perfectly fluid, and assuming them to be uninfluenced by the action of gravity, the following law has been established. It is often called *Pascal's law*, for it was first enunciated by him.

Pressure exerted anywhere upon a mass of liquid is transmitted undiminished in all directions, and acts with the same force on all equal surfaces, and in a direction at right angles to those surfaces.

To get a clearer idea of this principle, let us conceive a vessel of any given form in the sides of which are placed various cylindrical apertures, all of the same size, and closed by movable pistons. Let us, further, imagine this vessel to be filled with liquid and unaffected by the action of gravity; the pistons will, obviously, have no tendency to move. If now a force equal to the weight of P pounds is placed upon the piston A (fig. 75), which has an area of 1 sq. inch, it will be pressed inwards, and the pressure (P pounds per sq. inch) will be transmitted to the internal faces of each of the pistons B , C , D , and E , which will each be forced outwards by a pressure P ,

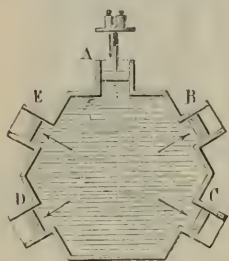

Fig. 75

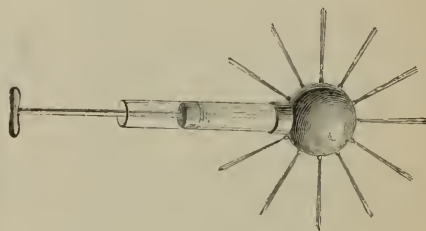

Fig. 76

their surfaces being equal to that of the first piston. Since each of the pistons is subjected to a pressure, P , equal to that on A , let us suppose two of the pistons united so as to constitute a surface of 2 sq. inches; it will have to support a pressure $2P$. Similarly, if the piston were equal to 3 sq. inches, it would experience a pressure of $3P$; and if its area were 100 or 1000 times that of A , it would sustain a pressure of 100 or 1000 times P . In other words, the force acting on any part of the internal walls of the vessel would be proportional to the surface, *i.e.* the pressure would be the same at all parts.

The principle of the equality of pressure is assumed as a consequence of the constitution of fluids. By the following experiment it can be shown that pressure is transmitted in all directions, although it cannot be shown that it is equally transmitted. A cylinder provided with a piston is fitted into a hollow sphere (fig. 76), in which small cylindrical jets are placed perpendicular to the sides. The sphere and the cylinder being both filled with water, when the piston is moved the liquid spouts forth from all the orifices, and not merely from that which is opposite to the piston.

The reason why a satisfactory quantitative experimental demonstration

of the principle of the equality of pressure cannot be given is, that the influence of the weight of the liquid and of the friction of the pistons cannot be altogether eliminated.

Yet an approximate verification may be effected by the experiment represented in fig. 77. Two cylinders of different diameters are joined by a tube and filled with water. On the surface of the liquid are two pistons, P and p , supposed to be without weight, which hermetically close the cylinders, but move without friction. Let the area of the large piston, P, be, for instance, thirty times that of the smaller one, p . That being assumed, let a weight, say of two pounds, be placed upon the small piston; this pressure will be transmitted to the water and to the large piston, and as this pressure amounts to two pounds *on each portion of its surface equal to that of the small piston*, the large piston must be exposed to an upward pressure thirty times as much, or of sixty pounds. If now this weight is placed upon the large piston, both will remain in equilibrium; but, if the weight is greater or less, this is no longer the case. If S and s are the areas of the large and small piston respectively, and P and p the corresponding loads, then $\frac{P}{p} = \frac{S}{s}$; whence $P = \frac{pS}{s}$. If instead of

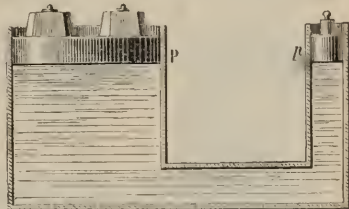

Fig. 77

being weightless the piston p weighs (say) one pound and the piston P ten pounds, it will be necessary to put a weight of fifty pounds on P to balance one pound put on p .

It is important to observe that in speaking of the transmission of pressures to the sides of the containing vessel, these pressures must always be supposed to be perpendicular to the sides; for any oblique pressure may be decomposed into two others, one at right angles to the side, and the other acting parallel with the side; but as the latter has no action on the side, the perpendicular pressure is the only one to be considered.

PRESSURE PRODUCED IN LIQUIDS BY GRAVITY

98. **Vertical downward pressure: its laws.**—Any given liquid being in a state of rest in a vessel, if we suppose it to be divided into horizontal layers of the same density, it is evident that each layer supports the weight of those above it. Gravity, therefore, produces internal pressures in the mass of a liquid, which vary at different points. These pressures are submitted to the following general laws:—

I. *The pressure in each layer is proportional to the depth.*

II. *With different liquids and the same depth, the pressure is proportional to the density of the liquid.*

III. *The pressure is the same at all points of the same horizontal layer.*

The first two laws are self-evident; the third necessarily follows from the first and from Pascal's principle.

Meyer has found, by direct experiments, that pressure is transmitted through liquids contained in tubes, with the same velocity as that with which sound travels in the same circumstances.

99. **Vertical upward pressure.**—The pressure which the upper layers of a liquid exert on the lower layers causes them to exert an equal reaction in an upward direction, a necessary consequence of the principle of transmission of pressure in all directions. This upward pressure is termed the *buoyancy* of liquids; it is very sensible when the hand is plunged into a liquid, more especially one of great density, like mercury.

The following experiment (fig. 78) serves to exhibit the upward pressure of liquids. A large open glass tube, A, one end of which is ground, is fitted with a ground-glass disc, O, or, still better, with a thin card or piece of mica, the weight of which may be neglected. To the disc is fitted a string, C, by which it can be held against the bottom of the tube. The whole is then immersed in water, and now the disc does not fall, although no longer held by the string; it is consequently kept in its position by the upward pressure of the water. If water is now slowly poured into the tube, the disc will only sink when the height of the water inside the tube is equal to the height outside. It follows thence that the upward pressure on the disc is equal to the pressure of a column of water, the base of which is the internal section of the tube A, and the height

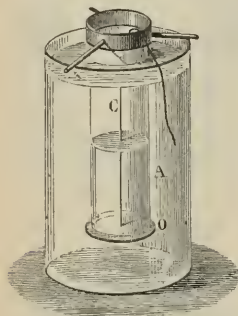

Fig. 78

the distance from the disc to the upper surface of the liquid. Hence the *upward pressure of liquids at any point is governed by the same laws as the downward pressure.*

100. **Pressure is independent of the shape of the vessel.**—The pressure exerted by a liquid, in virtue of its weight, on any portion of the liquid, or on the sides of the vessel in which it is contained, depends on the depth and density of the liquid, but *is independent of the shape of the vessel and of the quantity of the liquid.*

This principle, which follows from the law of the equality of pressure, may be experimentally demonstrated by many forms of apparatus. The following is the one most frequently used, and is due to Haldat. It consists of a bent tube, ABC (fig. 79), at one end of which, A, is fitted a stopcock, in which can be screwed two vessels, M and P, of the same height, but different in shape and capacity, the first being conical, and the other nearly cylindrical. Mercury is poured into the tube ABC, until its level nearly reaches A. The vessel M is then screwed on and filled with water. The pressure of the water acting on the mercury causes it to rise in the tube C, and its height may be marked by means of a little collar, *a*, which slides up and down the tube. The level of the water in M is also marked by means of the movable rod *o*. When this is done, M is emptied by means of the stopcock, unscrewed, and replaced by P. When water is now poured in this, the mercury, which had resumed its original level in the tube ABC, again rises in C, and when the water in P has the same height as it had in M, which is indicated by the rod *o*, the mercury will have risen to the height

it had before, which is marked by the collar *a*. Hence the pressure on the mercury in both cases is the same. This pressure is therefore independent of the shape of the vessels, and, consequently, also of the quantity of liquid. The base of the vessel is obviously the same in both cases; it is the surface of the mercury in the interior of the tube *A*.

Another mode of demonstrating this principle is by means of an apparatus devised by Masson. In this (fig. 80) the pressure of the water contained in the vessel *M* is not exerted upon the column of mercury, as in that of Haldat, but on a small disc or stop, *a*,

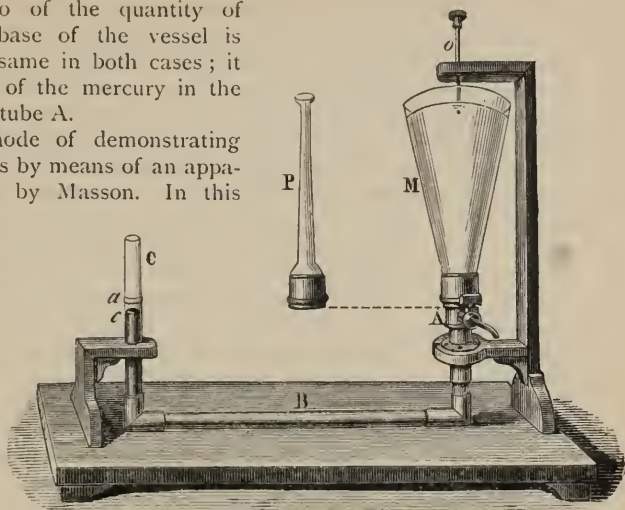

Fig. 79

which closes a tubulure, *c*, on which is screwed the vessel *M*. The disc is now fixed to the tubulure, but is sustained by a thread attached to the end

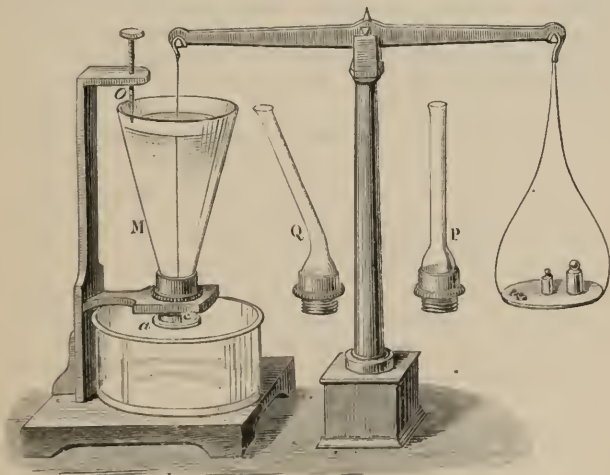

Fig. 80

of a scale-beam. At the other end is a pan, in which weights can be placed until they counterbalance the pressure exerted by the water on the stop.

The vessel M after being emptied is unscrewed, and replaced by the narrow tube P. This being filled to the same height as the large vessel, which is observed by means of the mark *a*, it will be observed that to keep the disc in its place just the same weight must be placed in the pan as before; which leads, therefore, to the same conclusion as does Haldat's experiment. The same result is obtained if, instead of the straight tube P, the oblique tube Q be screwed to the tubulure.

From a consideration of these principles it will be readily seen that a very small quantity of water can produce considerable pressures. Let us imagine any vessel—a cask, for example—filled with water, and with a long narrow vertical tube tightly fitted into the side. If water is poured into the tube, there will be a pressure on the bottom of the cask equal to the weight of a column of water whose base is the bottom itself, and whose height is that of the water in the tube. The pressure may be made as great as we please; by means of a narrow thread of water forty feet high Pascal succeeded in bursting a very solidly constructed cask.

The toy known as the *hydrostatic bellows* depends on the same principle, and we shall meet with a most important application of it in the hydraulic press (107).

From the principle just laid down, the pressures produced at the bottom of the sea may be calculated. It will be presently demonstrated that the pressure of the atmosphere is equal to that of a column of sea-water about 33 feet high. At sea the lead has frequently descended to a depth of 13,000 feet; at the bottom of some seas, therefore, there must be a pressure of 400 atmospheres.

101. **Pressure on the sides of vessels.**—Since the pressure caused by gravity in the mass of a liquid is transmitted in every direction, according to the general law of the transmission of fluid pressure, it follows that at every point of the side of any vessel a pressure is exerted, at right angles to the side, which we will suppose to be plane. The resultant of all these pressures is the total force on the sides. But since these pressures increase in proportion to the depth, and also in proportion to the horizontal extent of the side of the vessel, their resultant can only be obtained by calculation, which shows that the total pressure on any given portion of the side *is equal to the weight of a column of liquid which has this portion of the side for its base, and whose height is the vertical distance from the centre of gravity of the portion to the surface of the liquid.* If the side of a vessel is a curved surface, the same rule gives the pressure of the surface.

The point in the side assumed to be plane, at which the resultant of all the pressures (that is, the total force) is applied, is called the *centre of pressure* and is always below the centre of gravity of the side. For if the pressures exerted at different parts of the plane side were equal, the point of application of their resultant, the centre of pressure, would obviously coincide with the centre of gravity of the side. But since the pressure increases with the depth, the centre of pressure is necessarily below the centre of gravity. This point is determined by calculation, which leads to the following results:—

i. With a rectangular plate whose upper edge is level with the water, the centre of pressure is at two-thirds of the line which joins the middle of the horizontal sides measured from the top.

ii. With a triangular plate whose base is horizontal, and coincident with the level of the water, the centre of pressure is at the middle of the line which joins the vertex of the triangle with the middle of the base.

iii. With a triangular plate whose vertex is level with the water, the centre of pressure is in the line joining the vertex and the middle of the horizontal base, and at three-fourths of the distance of the latter from the vertex.

102. **Hydrostatic paradox.**—We have already seen that the pressure on the bottom of a vessel depends neither on the form of the vessel nor on the quantity of the liquid, but simply on the height of the liquid above the bottom. But the pressure thus exerted must not be confounded with the pressure which the vessel itself exerts on the body which supports it. The latter is always equal to the combined weight of the liquid and the vessel in which it is contained, while the former may be either smaller or greater than this weight, according to the form of the vessel. This fact is often termed the *hydrostatic paradox*, because at first sight it appears paradoxical.

CD (fig. 81) is a vessel composed of two cylindrical parts of unequal diameters, and filled with water to a . From what has been said before, the bottom of the vessel CD supports the same pressure as if its diameter were everywhere the same as that of its lower part; and it would at first sight seem that the scale MN of the balance, in which the vessel CD is placed, ought to show the same weight as if there had been placed in it a cylindrical vessel having the same height of water, and having the diameter of the part D. But the pressure exerted on the bottom of the vessel is not all transmitted to the scale MN; for the *upward* pressure upon the surface no of the vessel is precisely equal to the weight of the *extra* quantity of water which a cylindrical vessel would contain, and balances an equal portion of the *downward* pressure on m . Consequently the pressure on the plate MN is simply equal to the weight of the vessel CD and of the water which it contains.

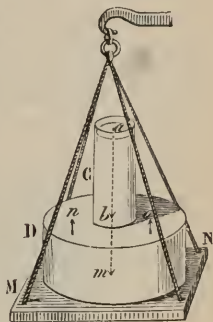

Fig. 81

CONDITIONS OF THE EQUILIBRIUM OF LIQUIDS

103. **Equilibrium of a liquid in a single vessel.**—In order that a liquid may remain at rest in a vessel of any given form, it must satisfy the two following conditions:—

I. *Its surface must be everywhere perpendicular to the resultant of the forces which act on the molecules of the liquid.*

II. *Every molecule of the mass of the liquid must be subject in every direction to equal and contrary forces.*

The second condition is self-evident; for if, in two opposite directions, the forces exerted on any given molecule were not equal and contrary, the molecule would be moved in the direction of the greater force and there would be no equilibrium. Thus the second condition follows from the principle of the equality of pressures, and from the reaction which all pressure causes on the mass of liquids.

To prove the first condition, let us suppose that mp is the resultant of all the forces acting upon any molecule m on the surface (fig. 82), and that this surface is inclined in reference to the force mp . The latter can consequently be decomposed into two forces, mq and mf ; the one perpendicular to the surface of the liquid, and the other to the direction mp . Now the first force mq would be destroyed by the resistance of the liquid, while the second would move the molecule in the direction mf , which shows that the equilibrium is impossible.

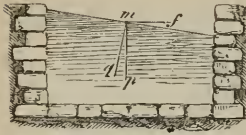

Fig. 82

If gravity is the force acting on the liquid, the direction mp is vertical; hence, if the liquid is contained in a basin or vessel of small extent, the surface ought to be plane and horizontal (69), because then the direction of gravity is the same in every point. But the case is different with liquid surfaces of greater extent like that of the ocean. The surface will be perpendicular to the direction of gravity; but as this changes from one point to another, and always tends towards a point near the centre of the earth, it follows that the direction of the surface of the ocean will change also, and assume a nearly spherical form.

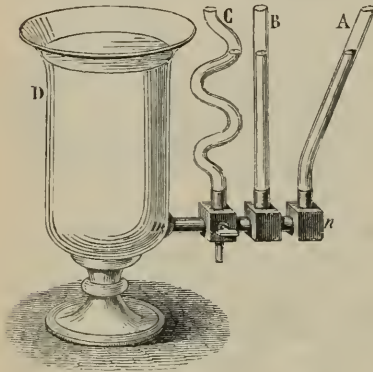

Fig. 83

104. **Equilibrium of the same liquid in several communicating vessels.**—When several vessels of any given form communicate with each other, there will be equilibrium when the liquid in each vessel satisfies the two preceding conditions (103), and further, *when the surfaces of the liquids in all the vessels are in the same horizontal plane.*

In the vessels $ABCD$ (fig. 83), which communicate with each other, let us consider any transverse section of the tube mn ; the liquid can only remain in equilibrium as long as the pressures which this section supports from m in the direction of n , and from n in the direction of m , are equal and opposite. Now it has been already proved that these pressures are respectively equal to the weight of a column of water, whose base is the supposed section, and whose height is the distance from the centre of gravity of this section to the surface of the liquid. If we conceive, then, a horizontal plane, mn , drawn through the centre of gravity of this section, it will be seen that there will only be equilibrium as long as the height of the liquid above this plane is the same in each vessel, which demonstrates the principle enunciated.

105. **Equilibrium of superposed liquids.**—In order that there may be equilibrium when several different liquids are superposed in the same vessel, each of them must satisfy the conditions necessary for a single liquid (103); and further, *there will be stable equilibrium only when the*

liquids are arranged in the order of their decreasing densities from the bottom upwards.

The last condition may be experimentally demonstrated by means of a long narrow bottle containing mercury, water saturated with potassium carbonate, alcohol coloured red, and petroleum. When the bottle is shaken the liquids mix, but when it is allowed to rest they separate; the mercury sinks to the bottom, then comes the water, then the alcohol, and then the petroleum. This is the order of the decreasing densities of the bodies. The water is saturated with potassium carbonate to prevent its mixing with the alcohol.

This separation of the liquids is due to the same cause as that which enables solid bodies to float on the surface of a liquid of greater density than their own. On this account, also, fresh water at the mouths of rivers floats for a long time on the denser salt water of the sea; and for the same reason cream, which is lighter than milk, rises to the surface.

106. **Equilibrium of two different liquids in communicating vessels.**—When two liquids of different densities, which do not mix, are contained in two communicating vessels, they will be in equilibrium when, in addition to the preceding principles, they are subject to the following condition: *that the heights above the horizontal surface of contact of two columns of liquid in equilibrium are in the inverse ratio of their densities.*

To show this experimentally, mercury is poured into a bent glass tube, *mn*, fixed against an upright wooden support (fig. 84), and then water is poured into one of the legs, *AB*. The column of water, *AB*, pressing on the mercury at *B*, lowers its level in the leg *AB*, and raises it in the other by a quantity, *CD*; so that if, when equilibrium is established, we imagine a horizontal plane, *BC*, to pass through *B*, the column of water in *AB* will balance the column of mercury, *CD*. If the heights of these two columns are then measured, it will be found that the height of the column of water is about $13\frac{1}{2}$ times that of the column of mercury. We shall presently see that the density of mercury is about $13\frac{1}{2}$ times that of water, from which it follows that the heights are inversely as the densities.

It may be added that the equilibrium cannot exist unless there is a sufficient quantity of the heavier liquid for part of it to remain in *both* legs of the tube.

The preceding principle may be deduced by a very simple calculation. Let *d* and *d'* be the densities of water and mercury, and *h* and *h'* their respective heights, and let *g* be the acceleration due to gravity. The pressure on *B* will be proportional to the density of the liquid, to its height, and to *g*; on the whole, therefore, to the product *dhg*. Similarly, the pressure at *C* will be proportional to *d'h'g*. But in order to produce equilibrium,

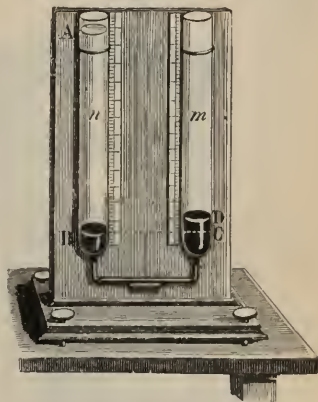

Fig. 84

dhg must be equal to $d'h'g$, or $dh = d'h'$. This is nothing more than an algebraical expression of the above principle; for since the two products must always be equal, d' must be as many times greater than d as h' is less than h .

In this manner the density of a liquid may be determined. Suppose one of the branches contained water and the other oil, and their heights above their common surface were, respectively, 15 inches for the oil and 14 inches for the water. The density of water being taken as unity, and that of oil being called x , we shall have

$$15 \times x = 14 \times 1; \text{ whence } x = \frac{14}{15} = 0.933.$$

APPLICATIONS OF THE PRECEDING HYDROSTATIC PRINCIPLES

107. **Hydraulic press.**—The law of the equal transmission of fluid pressure has received a most important application in the *hydraulic press*, a machine

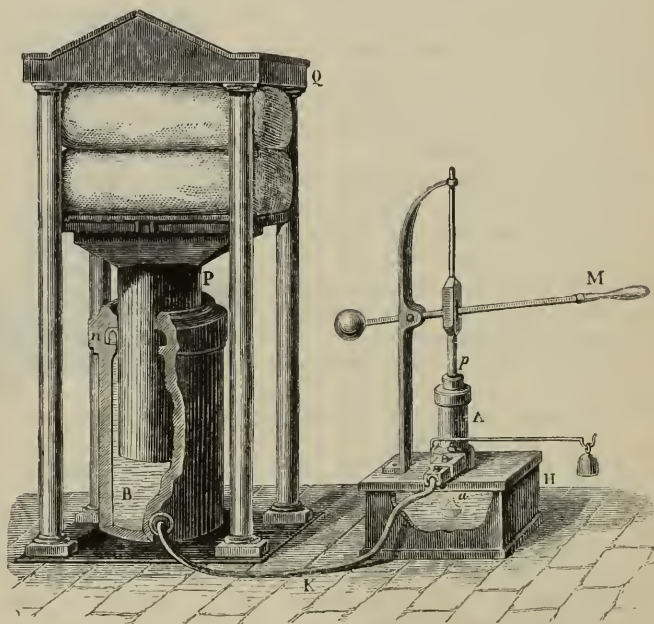

Fig. 85

by which enormous pressures may be produced. Its principle is due to Pascal, but it was first constructed by Bramah in 1796.

It consists of a cylinder, B, with very strong thick sides (fig. 85), in which there is a cast-iron ram, P, working water-tight in the collar of the cylinder. On the ram P there is a cast-iron plate on which the substance

to be pressed is placed. Four strong columns serve to support and fix a second plate, Q.

By means of a leaden pipe, K, the cylinder B, which is filled with water, communicates with a small force-pump, A, which works by means of a lever, M. When the piston of this pump, ϕ , ascends, water rises in the tube a , at the end of which there is a rose, to prevent the entrance of foreign matters. When the piston ϕ descends, it drives the water into the cylinder by the tube K.

Fig. 86 represents a section, on a larger scale, of the system of valves necessary in working the apparatus. The valve a , below the piston ϕ , opens when the piston rises, and closes when it descends. The valve below h , during this descent, is opened by the pressure of the water which passes by the pipe K. The valve i is a *safety-valve*, held by a weight which acts on it by means of a lever. By weighting the latter to a greater or less extent the pressure can be regulated, for as soon as there is an upward pressure greater than that due to the weight upon it, it opens and water escapes. A screw, r , serves to relieve the pressure, for when it is opened it affords a passage for the efflux of the water in the cylinder B.

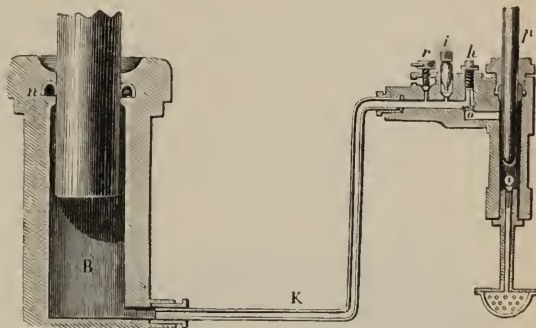

Fig. 86

A most important part is the leather collar, n , the invention of which by Bramah removed the difficulties which had been experienced in making the large ram work water-tight when submitted to great pressures. It consists of a circular piece of stout leather (fig. 87), saturated with oil so as to be impervious to water, in the centre of which a circular hole is cut. This piece is bent so that a section of it represents a reversed U, and is fitted into a groove, n , made in the neck of the cylinder. The collar, being concave downwards, fits the more tightly as the pressure increases against the ram P on one side and the neck of the cylinder on the other, and quite prevents any escape of water.



Fig. 87

The pressure which can be obtained by this press depends on the relation of the diameter of the piston P to that of the piston ϕ . If the former has a transverse section fifty or a hundred times as large as the latter, the upward pressure on the large piston will be fifty or a hundred times that exerted upon the small one. By means of the lever M an additional advantage is obtained. If the distance from the fulcrum to the point where the force is applied is five times the distance from the fulcrum to the piston ϕ , the pressure on ϕ will be

five times the force applied. Thus, if a man acts on M with a force of sixty pounds, the force transmitted by the piston p will be 300 pounds, and the force which tends to raise the piston P will be 30,000 pounds, supposing the section of P is a hundred times that of p .

The hydraulic press is used in cases in which great pressures are required. It is used in pressing cloth and paper, in extracting the juice of beet-root, in compressing hay and cotton, in expressing oil from seeds, and in bending iron plates; it also serves to test the strength of cannon, of steam boilers, and of chain cables. The parts composing the tubular bridge which spans the Menai Straits were raised by means of a hydraulic press. The cylinder of this machine, the largest which had ever been constructed, was nine feet long and twenty-two inches in internal diameter; it was capable of raising a weight of two thousand tons.

The principle of the hydraulic press is advantageously employed in cases in which great power is only required at intervals, such as in opening dock gates, working cranes, in lifts in hotels, warehouses, and the like. It has even been used in working stage machinery. In these cases a hydraulic *accumulator* is used. The piston P is loaded with very great weights, and water is continually forced into the cylinder B by powerful pumps. From the bottom of this cylinder a tube conducts water to any place where the power is to be applied, and the flow of even small quantities of water which is under high pressure can perform a great amount of work.

Suppose, for instance, that the area of the piston P is four square feet, and that it has a load of 100 tons; this represents a pressure of over 370 pounds on the square inch, or more than 25 atmospheres. When the large piston sinks through one-seventeenth of an inch, about a pint of water will flow out, and this represents a work of about 1100 foot-pounds. In London hydraulic power is supplied by water delivered under a pressure of 700 pounds per square inch (165).

108. **The water-level.**—The *water-level* is an application of the conditions of equilibrium in communicating vessels. It consists of a metal tube

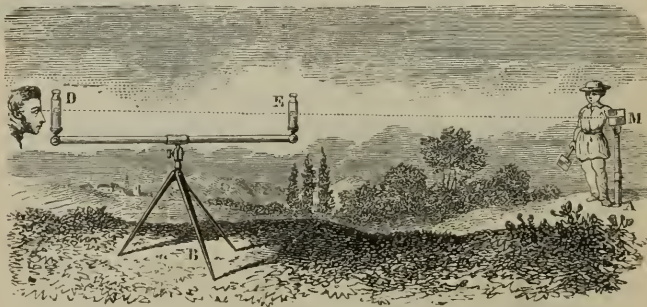

Fig. 88

bent at both ends, in which are fitted glass tubes, D and E (fig. 88). It is placed on a tripod, and water poured in until it rises in both legs. When the

liquid is at rest, the level of the water in both tubes is the same; that is, they are both in the same horizontal plane.

This instrument is used in levelling, or ascertaining how much one point is higher than another. If, for example, it is desired to find the difference between the heights of B and A, a *levelling-staff* is fixed on the latter place. This staff consists of a rule formed of two sliding pieces of wood, and supporting a piece of tin plate, M, at the centre of which there is a mark. This staff being held vertically at A, an observer looks at it through the level along the surfaces D and E, and directs the holder to raise or lower the slide until the mark is in the prolongation of the line DE. The height AM is then measured, and, subtracting it from the height of the level, the height of the point A above B is obtained.

109. **The spirit-level.**—The *spirit-level* is both more delicate and more accurate than the water-level. It consists of a glass tube, AB (fig. 89), very slightly curved; that is,

Fig. 89

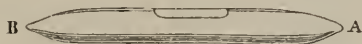

instead of being a true cylinder as it seems to be, is in fact slightly curved in such a manner that its axis is an arc of a circle of very large radius. It is filled with spirit with the exception of a bubble of air, which tends to occupy the highest part. The tube is placed in a brass case, CD (fig. 90), which is so arranged that when it is in a perfectly horizontal position the bubble of air is exactly between the two points marked in the case.

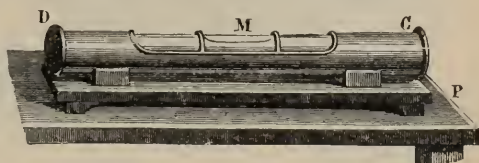

Fig. 90

To take levels with this apparatus, it is fixed on a telescope, which can be placed in a horizontal position.

110. **Artesian wells.**—All natural collections of water exemplify the tendency of water to find its level. Thus a group of lakes, such as the great lakes of North America, may be regarded as a number of vessels in communication, and consequently the water tends to maintain the same level in all. This, too, is the case with a source of a river and the sea, and, as the latter is on the lower level, the river continually flows down to the sea along its bed, which is, in fact, the means of communication between the two.

Perhaps the most striking instance of this class of natural phenomena is that of *artesian wells*. These wells derive their name from the province of Artois, where it has long been customary to dig them, and whence their use in other places was derived. It seems, however, that at a very remote period wells of the same kind were dug in China and Egypt.

The strata composing the earth's crust are of two kinds: the one *permeable* to water, such as sand, gravel, &c.; the other *impermeable*, such as clay. Let us suppose, then, a geographical basin of greater or less extent, in which the two impermeable layers AB, CD (fig. 91), enclose between them a

permeable layer, KK. The rain-water falling on that part of this layer which comes to the surface, and which is called the *outcrop*, will filter through it, and, following the natural fall of the ground, will collect in the hollow of the basin, whence it cannot escape owing to the impermeable strata above and below it. If, now, a vertical hole, I, is sunk down to the water-bearing stratum, the water striving to regain its level will spout out to a height which depends on the difference between the levels of the outcrop and of the point at which the perforation is made.

The waters which feed artesian wells often come from a distance of 60 or 70 miles. The depth varies in different places. The well at Grenelle

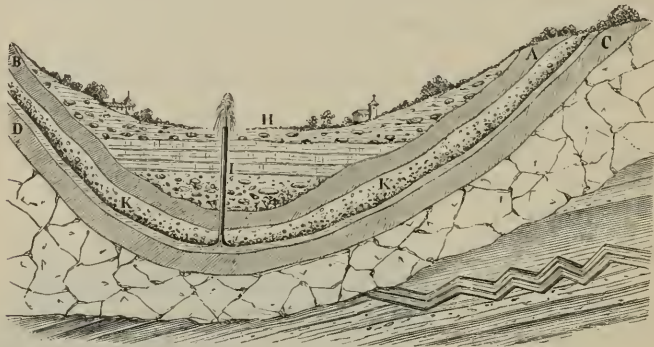

Fig. 91

is 1800 feet deep ; it gives 656 gallons of water in a minute, and is one of the deepest and most abundant which have been made. The temperature of the water is 27° C. It follows from the law of the increase of temperature with the increasing depth below the surface, that, if this well were 210 feet deeper, the water would have all the year round a temperature of 32° C. ; that is, the ordinary temperature of warm baths.

BODIES IMMERSED IN LIQUIDS

111. **Pressure on a body immersed in a liquid.**—When a solid is immersed in a liquid, every portion of its surface is submitted to a perpendicular pressure which increases with the depth. If we imagine all these pressures decomposed into horizontal and vertical pressures, the first set are in equilibrium. The vertical pressures are obviously unequal, and will tend to move the body upwards.

Let us imagine a cube immersed in a mass of water (fig. 92), and that four of its edges are vertical. The pressures upon the four vertical faces being clearly in equilibrium, we need only consider the pressures exerted on the horizontal faces A and B. The first is pressed downwards by a column of water whose base is the face A, and whose height is AD ; the lower face B is pressed upwards by the weight of a column of water whose base is the face itself, and whose height is BD (99). The cube, therefore, is urged

upwards by a force equal to the difference between these two forces, which latter is manifestly equal to the weight of a column of water having the same base and the same height as this cube. *Consequently, this upward force is equal to the weight of the volume of water displaced by the immersed body.*

We shall readily see from the following reasoning that every body immersed in a liquid is pressed upwards by a force equal to the weight of the displaced liquid. In a liquid at rest let us suppose a portion of it of any given shape, regular or irregular, to become solidified, without either increase or decrease of volume. The liquid thus solidified will remain at rest, and therefore must be acted upon by a force equal to its weight, and acting vertically upwards through its centre of gravity; for otherwise motion would ensue. If in the place of the solidified water we imagine a solid of another substance of exactly the same volume and shape, it will necessarily receive the same pressures from the surrounding liquid as the solidified portion did; hence, like the latter, it will sustain a force acting vertically upwards through the centre of gravity of the displaced liquid, and equal to the weight of the displaced liquid. If, as almost invariably happens, the liquid is of uniform density, the centre of gravity of the displaced liquid means the centre of gravity of the immersed part of the body *supposed to be of uniform density*. This distinction is sometimes of importance: for example, if a sphere is composed of a hemisphere of iron and another of wood, its centre of gravity would not coincide with its geometrical centre, but, if it were placed under water, the centre of gravity of the displaced water would be at the geometrical centre—that is, would have the same position as the centre of gravity of the sphere if of uniform density.

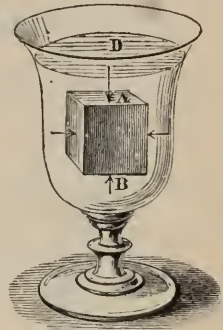

Fig. 92

112. Principle of Archimedes.—The preceding principles prove that every body immersed in a liquid is submitted to the action of two forces: gravity, which tends to lower it, and the buoyancy of the liquid, which tends to raise it with a force equal to the weight of the liquid displaced. The weight of the body is either totally or partially balanced by its buoyancy, so that *a body immersed in a liquid loses a part of its weight equal to the weight of the displaced liquid.*

This principle, which is the basis of the theory of immersed and floating bodies, is called the principle of Archimedes, after the discoverer. It may be shown experimentally by means of the *hydrostatic balance* (fig. 93). This is an ordinary balance, each pan of which is provided with a hook; the beam can be raised by means of a toothed rack, which is worked by a little pinion C. A catch, D, holds the rack when it has been raised. The beam being raised, a hollow brass cylinder, A, is suspended from one of the pans, and below this a solid cylinder, B, whose volume is exactly equal to the capacity of the first cylinder; lastly, an equipoise is placed in the other pan. If now the hollow cylinder A is filled with water, the equilibrium is disturbed;

but if at the same time the beam is lowered so that the solid cylinder B becomes immersed in a vessel of water placed beneath it, the equilibrium will be restored. By being immersed in water the cylinder B loses a portion of its weight equal to that of the water in the cylinder A. Now, as the capacity of the cylinder A is exactly equal to the volume of the cylinder B, the principle which has been before laid down is proved.

113. **Determination of the volume of a body.**—The principle of Archimedes furnishes a method for obtaining the volume of a body of any shape, provided it is not soluble in water. The body is suspended by a fine

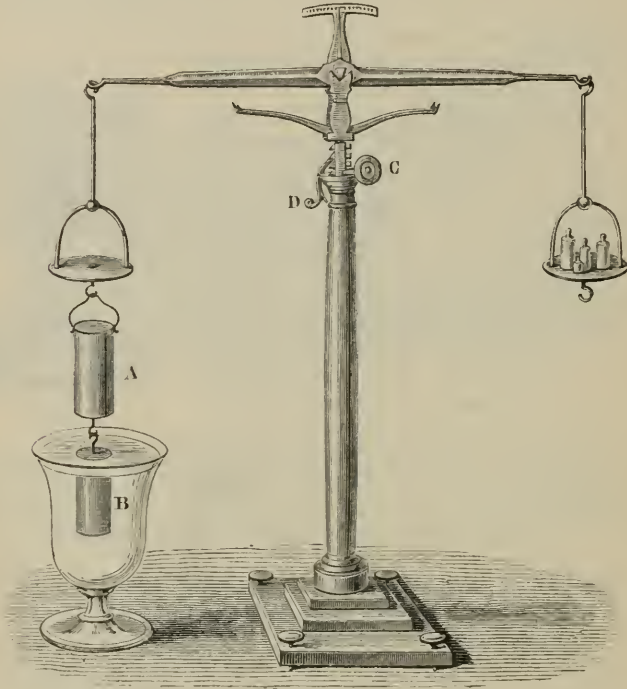

Fig. 93

thread to the hydrostatic balance, and is weighed first in the air, and then in distilled water at 4° C. The loss of weight is the weight of the displaced water, from which the volume of the displaced water is readily calculated. But this volume is manifestly that of the body itself. Suppose, for example, 155 grammes is the loss of weight. This is consequently the weight of the displaced water. Now it is known that a gramme is the weight of a cubic centimetre of water at 4° ; consequently, the volume of the body immersed is 155 cubic centimetres.

114. **Equilibrium of floating bodies.**—A body when floating is acted on by two forces—namely, its weight, which acts vertically downwards

through its centre of gravity, and the resultant of the fluid pressures, which (111) acts vertically upwards through the centre of gravity of the fluid displaced; but if the body is at rest these two forces must be equal and act in opposite directions; whence follow the conditions of equilibrium, namely—

- i. *The floating body must displace a volume of liquid whose weight equals that of the body.*
- ii. *The centre of gravity of the floating body must be in the same vertical line with that of the fluid displaced.*

Thus in fig. 94, if C is the centre of gravity of the body, and G that of the displaced fluid, the line GC must be vertical, since when it is so the weight of the body and the fluid pressure will act in opposite direction along the same line, and will be in equilibrium if equal. It is convenient, with reference to the subject of the present article, to speak of the line CG produced, as the axis of the body.

Next, let it be inquired whether the equilibrium is stable or unstable. Suppose the body to be turned through a small angle (fig. 95), so that the axis takes a position inclined to the vertical.

The centre of gravity of the displaced fluid will no longer be G, but some other point, G'. And since the fluid pressure acts vertically upwards through G', its direction will cut the axis in some point M, which will generally have different positions according as the inclination of the axis to the vertical is greater or smaller.

If the angle is indefinitely small, M will have a definite position which always admits of determination, and is called the *metacentre*.

If we suppose M to be above C, an inspection of fig. 95 will show that when the body has received an indefinitely small displacement, the weight of the body acting at C, and the resultant of the fluid pressures acting through M, tend to bring the body back to its original position; that is, in this case, the equilibrium is stable (72). If, on the contrary, M is below C (fig. 96), the forces tend to cause the axis to deviate farther from the vertical, and the equilibrium is unstable. Hence the rule—

- iii. *The equilibrium of a floating body is stable or unstable according as the metacentre is above or below the centre of gravity.*

The determination of the metacentre can rarely be effected except by means of a somewhat difficult mathematical process. When, however, the form of the immersed part of a body is spherical, it can be readily determined; for since the fluid pressure at each point converges to the centre, and continues to do so when the body is slightly displaced, their resultant must in all cases pass through the centre, which is therefore the metacentre. To illustrate this: let a spherical body float on the surface of a

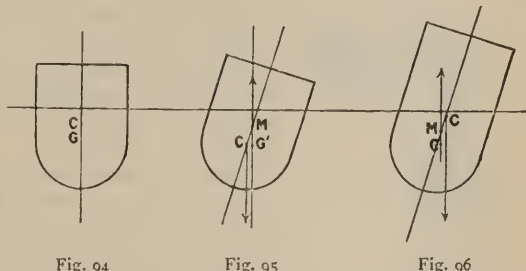

Fig. 94

Fig. 95

Fig. 96

liquid (fig. 97); then its centre of gravity and the metacentre both coinciding with the geometrical centre, C , its equilibrium is neutral (72). Now

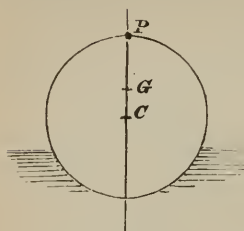

Fig. 97

suppose a small heavy body to be fastened at P , the summit of the vertical diameter. The centre of gravity will now be at some point, G , above C . Consequently, the equilibrium is unstable, and the sphere, left to itself, will instantly turn over and will rest when P is the lower end of a vertical diameter.

On investigating the position of the metacentre of a cylinder, it is found that, where the ratio of the radius to the height is greater than a certain quantity, the position of stable equilibrium is that in which the axis is vertical; but if it be less than that quantity, the equilibrium is stable when the axis is horizontal. For this reason the stump of a tree floats lengthwise, but a thin disc of wood floats flat on the water. Hence, also, if it is required to make a cylinder of moderate length float with its axis vertical, it is necessary to load it at the lower end. In this way its centre of gravity is brought below the metacentre.

The determination of the metacentre and of the centre of gravity is of great importance in the loading of vessels, for on their relative positions the stability depends.

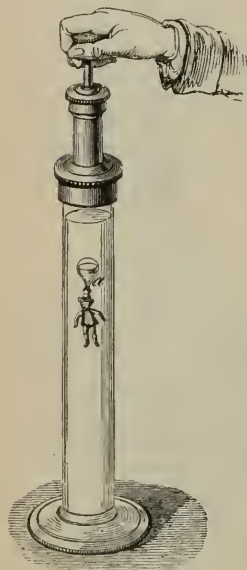

Fig. 98

115. **Cartesian diver.**—The different effects of suspension, immersion, and floating are reproduced by means of a well-known hydrostatic toy, the *Cartesian diver* (fig. 98). It consists of a glass cylinder nearly full of water, on the top of which a brass cap, provided with a piston, is hermetically fitted. In the liquid there is a little porcelain figure attached to a hollow glass ball, a , which contains air and water, and floats on the surface. In the lower part of this ball there is a little hole by which water can enter or escape, according as the air in the interior is more or less compressed. The quantity of water in the globe is such that very little more is required to make the figure sink. If the piston is slightly lowered the air is compressed, and this pressure is transmitted to the water of the vessel and the air in the bulb.

The compression of the air allows a small quantity of water to penetrate into the bulb, which therefore becomes heavier and sinks. If the pressure is relieved, the air in the bulb expands, expels the excess of water which had entered it, and the apparatus, being now lighter, rises to the surface. The apparatus may be simplified by replacing the brass cap and piston by a cover of sheet india rubber, which is tightly tied over the mouth; when this is pressed by the hand the same effects are produced.

116. **Swimming-bladder of fishes.**—Most fishes have an air-bladder below the spine, which is called the *swimming-bladder*. The fish can compress or dilate this at pleasure by means of a muscular effort, and produce the same effects as those just described—that is, it can either rise or sink in water.

117. **Swimming.**—The human body is lighter, on the whole, than an equal volume of water, the average ratio being as 0.934 : 1; it consequently floats on the surface, and is still better in sea-water, which is heavier than fresh water. The difficulty in swimming consists, not so much in floating, as in keeping the head above water, so as to breathe freely. In man the head is heavier than the lower parts, and consequently tends to sink, and hence swimming is an art which requires to be learned. With quadrupeds, on the contrary, the head, being less heavy than the posterior parts of the body, remains above water without any effort, and these animals therefore swim naturally.

SPECIFIC GRAVITY—HYDROMETERS

118. **Determination of specific gravities.**—It has been already explained (27) that the specific gravity of a body, whether solid or liquid, is the number which expresses the relation of the weight of a given volume of this body to the weight of the same volume of distilled water at a temperature of 4°. In order, therefore, to calculate the specific gravity of a body, it is sufficient to determine its weight and that of an equal volume of water, and then to divide the first weight by the second: the quotient is the specific gravity of the body.

Three methods are commonly used in determining the specific gravities of solids and liquids. These are—1st, the method of the hydrostatic balance; 2nd, that of the hydrometer; and 3rd, the specific gravity flask. All three, however, depend on the same principle—that of first ascertaining the weight of a body, and then the weight of an equal volume of water. We shall apply these methods to the determination of the specific gravity, first, of solids, and then of liquids.

119. **Specific gravity of solids.**—i. *Hydrostatic balance.*—To obtain the specific gravity of a solid by the hydrostatic balance (fig. 93), the body is first weighed in the air, and is then suspended to the hook of the balance and weighed in water (fig. 99). The loss of weight which it experiences is, according to Archimedes' principle, the weight of its own volume of water; consequently, dividing the weight in air by the loss of weight in water, the quotient is the specific gravity required. If P is the weight of the body in air, P' its weight in water, and D its specific gravity, $P - P'$ being the weight of the displaced water,

$$\text{we have } D = \frac{P}{P - P'}$$

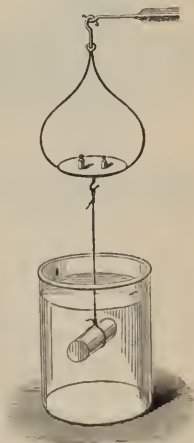

Fig. 99

It may be observed that, though the weighing is performed in air, yet, strictly speaking, the quantity required is the weight of the body *in vacuo*; and when great accuracy is required, it is necessary to apply to the observed

weights a correction for the weights of the unequal volumes of air displaced by the substance, and by the weights in the other scale-pan. The water in which bodies are weighed is supposed to be distilled water at the standard temperature.

ii. *Nicholson's hydrometer*.—The apparatus consists of a hollow metal cylinder, B (fig. 100), to which is fixed a cone, C, loaded with lead. The object of the latter is to bring the centre of gravity below the metacentre, so that the cylinder may float with its axis vertical. At the top is a stem terminated by a pan, in which is placed the substance whose specific gravity is to be determined. On the stem a standard point, *o*, is marked.

The apparatus stands partly out of the water, and the first step is to ascertain the weight which must be placed in the pan in order to make the hydrometer sink to the standard point *o*. Let this weight be 12.5 grammes, and let sulphur be the substance whose specific gravity is to be determined. The weights are removed from the pan, and replaced by a piece of sulphur which weighs less than 12.5 gr., and weights added till the hydrometer is again depressed to the point *o*. If, for instance, it has been necessary to add 5.5 gr., the weight of the sulphur is evidently the difference between 12.5 and 5.5 gr.; that is, 7 gr. Having thus determined the weight of the sulphur in air, it is only necessary to ascertain the weight of an equal volume of water. To do this, the piece of sulphur is placed in the lower pan, C, at *m*, as represented in the figure. The whole weight is not changed; nevertheless, the hydrometer no longer sinks to the standard; the sulphur, by immersion, has lost a part of its weight equal to that of the water displaced. Weights are added to the upper pan until the hydrometer sinks again to the standard mark. This weight, 3.44 gr., for example, represents the weight of the volume of water displaced; that is, of

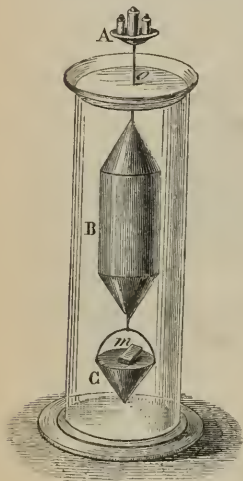

Fig. 100

the volume of water equal to the volume of the sulphur. It is only necessary, therefore, to divide 7 gr., the weight in air, by 3.44 gr., and the quotient, 2.03, is the specific gravity.

If the body in question is lighter than water, it tends to rise to the surface, and will not remain in the lower pan C. To obviate this, a small movable cage of fine wire is adjusted so as to prevent the ascent of the body. The experiment is in other respects the same.

120. **Specific gravity bottle. Pycnometer.**—When the specific gravity of a substance in a state of powder is required, it can be found most conveniently by means of the *pycnometer* or *specific gravity bottle*. This instrument is a bottle, in the neck of which is fitted a thermometer, A, an enlargement on the stem being carefully ground for this purpose (fig. 101). In the side is a narrow stem widened at the top and provided with a stopper, as shown in the figure. On this tube is a mark, *m*, and the thermometer stopper having been inserted, the bottle is filled with water exactly to this mark at each weighing. The bottle may conveniently have dimensions

such that when the thermometer stopper is inserted and the liquid filled to the mark *m*, it represents a definite volume. This is done by filling the bottle when wholly under water, and putting in the stopper while it is immersed. The bottle and the tube are then completely filled, and the quantity of water in excess is removed by blotting-paper. To find the specific gravity, proceed as follows: Having weighed the powder, place it in one of the scale-pans, and with it the bottle filled exactly to *m*, and carefully dried. Then balance it by placing small shot, or sand, in the other pan. Next, remove the bottle and pour the powder into it, and, as before, fill it up with water to the mark *m*. On replacing the bottle in the scale-pan it will no longer balance the shot, since the powder has displaced a volume of water equal to its own volume. Place weights in the scale-pan along with the bottle until they balance the shot. These weights give the weight of the water displaced. Then the weight of the powder and the weight of an equal bulk of water being known, the specific gravity of the powder is determined as before. The thermometer gives the temperature at which the determination is made, and thus renders it easy to make a correction (123).

It is important in this determination to remove the layer of air which adheres to the powder, and unduly increases the quantity of water expelled. This is effected by placing the bottle under the receiver of an air-pump and working the pump. Under the reduced pressure the air adhering to the powder expands, comes to the surface, and is thus got rid of. The same result is obtained by boiling the water in which the powder is placed.

121. Specific gravity of bodies soluble in water.—If the body whose specific gravity is to be determined by any of these methods is soluble in water, the determination is made in some liquid in which it is not soluble, such as oil of turpentine or naphtha, the specific gravity of which is known or is separately determined. The specific gravity is obtained by multiplying the number obtained in the experiment by the specific gravity of the liquid used for the determination.

Suppose, for example, a determination of the specific gravity of potassium has been made in naphtha. For equal volumes, *P* represents the weight of the potassium, *P'* that of the naphtha, and *P''* that of water; consequently, *P/P'* will be the specific gravity of the substance in reference to naphtha, and *P/P''* the specific gravity of the naphtha in reference to water. The product of these two fractions *P/P''* is the specific gravity of the substance compared with water.

A specific gravity bottle of a more simple kind is shown in fig. 104.

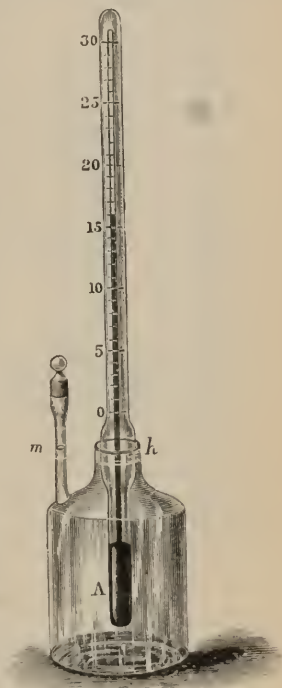

Fig. 101

Porous substances, whose specific gravities are required, are varnished before being immersed in water, which renders them impervious to moisture without altering their volume.

Specific gravity of solids at zero as compared with distilled water at 4° C.

Platinum, rolled	22·069	Rock crystal	2·653
„ cast	20·337	St. Gobin glass	2·488
Gold, stamped	19·362	China porcelain	2·380
„ cast	19·258	Sèvres porcelain	2·140
Lead, cast	11·352	Native sulphur	2·043
Silver, cast	10·474	Common salt	2·220
Bismuth, cast	9·822	Ivory	1·917
Copper, drawn wire	8·878	Anthracite	1·800
„ cast	8·788	Magnesia	1·740
Bronze coinage	8·660	Boxwood	1·330
German silver	8·432	Compact coal	1·329
Brass	8·383	Amber	1·078
Steel, not hammered	7·816	Sodium	0·970
Iron, bar	7·788	Ice at 0° C.	0·930
„ cast	7·207	Paraffin	0·874
Tin, cast	7·291	Potassium	0·865
Zinc, cast	6·861	Beech	0·852
Antimony, cast	6·712	Oak	0·845
Iodine	4·950	Elm	0·800
Heavy spar	4·430	Yellow pine	0·657
Faraday's glass	4·360	Lithium	0·585
Diamond	3·531 to 3·501	Common poplar	0·389
Flint glass	3·329	Cork	0·240
Statuary marble	2·837	Snow	0·183
Aluminium	2·680	Pith	0·055

In this table the different woods are supposed to be in the ordinary air-dried condition.

122. **Specific gravity of liquids.**—i. *Method of the hydrostatic balance.*—

From the pan of the hydrostatic balance a body is suspended, on which the liquid whose specific gravity is to be determined exerts no chemical action: for example, a ball of platinum. This is then successively weighed in air, in distilled water, and in the liquid. The loss of weight of the body in these two liquids is noted. They represent respectively the weights of equal volumes of water and of the given liquid, and consequently it is only necessary to divide the second of them by the first to obtain the required specific gravity.

Let P be the weight of the platinum ball in air, P' its weight in water, P'' its weight in the given liquid, and let D be the specific gravity sought. The weight of the water displaced by the platinum is $P - P'$, and that of the second liquid is $P - P''$, from which we get $D = \frac{P - P''}{P - P'}$.

ii. *Fahrenheit's hydrometer.*—This instrument (fig. 102) resembles Nicholson's hydrometer, but it is made of glass, so as to be used in all liquids. At

its lower extremity, instead of a pan, it is loaded with a small bulb containing mercury. There is a standard mark on the stem.

The weight of the instrument is first accurately determined in air; it is then placed in water, and weights added to the scale-pan until the mark on the stem is level with the water. It follows, from the first principle of the equilibrium of floating bodies, that the weight of the hydrometer together with the weight in the scale-pan, is equal to the weight of the volume of the displaced water. In the same manner the weight of an equal volume of the given liquid is determined, and the specific gravity is found by dividing the latter weight by the former.

Neither Fahrenheit's nor Nicholson's hydrometer gives such accurate results as the hydrostatic balance or the specific gravity bottle.

iii. *Specific gravity bottle.*—One form of this has been already described (120). In determining the specific gravity of a liquid, a bottle of special construction is used; it consists of a cylindrical reservoir, *b* (fig. 103), to which is fused a capillary tube, *c*, and to this again a wider tube, *a*, closed with a stopper. The bottle is first weighed empty, and then full of water to the mark *c* on the capillary stem, and afterwards of the given liquid. If the weight of the bottle is subtracted from the two weights thus obtained, the result represents the weights of equal volumes of the liquid and of water, from which the specific gravity is obtained by division.

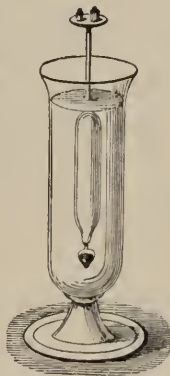

Fig. 102



Fig. 103

Another common form of specific gravity bottle is shown in fig. 104. It consists of a bottle of about 25 c.c. capacity, fitted with a well ground-in solid glass stopper perforated by a fine capillary tube. The bottle is completely filled with liquid and the stopper inserted. The excess of liquid escapes by the capillary channel in the stopper, and is removed by blotting-paper.

iv. *Specific gravity bulbs.*—The specific gravity of a liquid is often determined for technical and even scientific purposes by means of *specific gravity bulbs*; these are small hollow glass bulbs (fig. 105), which are prepared in series, loaded and adjusted so that they exactly float in a liquid of a definite specific gravity. When carefully prepared they are capable of giving results of considerable accuracy.



Fig. 104



Fig. 105

Solutions of certain metallic salts of high specific gravity have been used for the mechanical separation of individual minerals of certain rocks. Such minerals will float or sink according as their specific gravities are lower or higher than that of a given solution. A saturated solution of the double iodide of barium and mercury, the specific gravity of which is 3.58, has been used for this purpose. A saturated solution of cadmium borogstate has the specific gravity 3.3.

An application of this principle consists in taking a liquid such as methylene iodide (sp. gr. 3.3) on which a mineral will float, and then adding to it benzole until the mineral just remains suspended. Its specific gravity is then that of the liquid mixture, which is determined by a pyknometer (120).

123. **On the observation of temperature in ascertaining specific gravities.** As the volume of a body increases with the temperature, and as this increase varies with different substances, the specific gravity of any given body is not exactly the same at different temperatures; and, consequently, a certain fixed temperature is chosen for these determinations. That of water, for example, has been made at 4° C., for at this point it has the greatest density. The specific gravities of other bodies are assumed to be taken at zero; but, as this is not always possible, certain corrections must be made which we shall consider in the Book on Heat.

Specific gravities of liquids at zero, compared with that of water at 4° C. as unity

Mercury	13.598	Urine	1.020
Methylene iodide	3.342	Distilled water at 4° C.	1.000
Bromine	2.960	" " at 0° C.	0.999
Ethylic iodide	1.946	Claret	0.994
Sulphuric acid	1.841	Olive oil	0.915
Chloroform	1.525	Liquid oxygen	0.899
Nitric acid	1.420	Oil of turpentine	0.870
Bisulphide of carbon	1.293	Oil of lemon	0.852
Glycerine	1.260	Petroleum	0.836
Hydrochloric acid	1.240	Liquid carbonic acid	0.830
Blood	1.060	Absolute alcohol	0.793
Milk	1.029	Ether	0.713
Sea-water	1.026	Pentane	0.626

Liquid hydrogen is the lightest liquid known. Its density at -253° C., according to Dewar, is .071, or $\frac{1}{14}$ th that of water.

124. **Hydrometers of variable immersion.**—The hydrometers of Nicholson and Fahrenheit are called *hydrometers of constant immersion, but variable weight*, because they are always immersed to the same extent, but carry different weights. There are also *hydrometers of variable immersion, but of constant weight*.

125. **Beaumé's hydrometer.**—This, which was the first of these instruments, may serve as a type of them. It consists of a glass tube (fig. 106) loaded at the bottom with mercury, and with a bulb blown in the middle. The stem, the external diameter of which is as regular as possible, is hollow, and the scale is marked upon it.

The graduation of the instrument differs according as the liquid for which it is to be used is heavier or lighter than water. In the first case, it is so constructed that it sinks in water nearly to the top of the stem, to a point A, which is marked zero. A solution of 15 parts of salt in 85 parts of water is made, and the instrument immersed in it. It sinks to a certain point on the stem B, which is marked 15; the distance between A and B

is divided into 15 equal parts, and the graduation continued to the bottom of the stem. Sometimes the graduation is on a piece of paper inside the stem.

The hydrometer thus graduated only serves for liquids of a greater specific gravity than water, such as acids and saline solutions. For liquids lighter than water a different plan must be adopted. Baumé took for zero the point to which the apparatus sank in a solution of 10 parts of salt in 90 of water, and for 10 he took the level in distilled water. This distance he divided into 10 parts, and continued the division to the top of the scale.

Twaddell's hydrometer is in common use in England for testing liquids denser than water. It is graduated in such a manner that the reading or number of degrees multiplied by 5 and added to 1000 gives the specific gravity with reference to water at 1000. Thus 10° Twaddell represents the specific gravity 1050, and 90° represents 1450.

The graduation of these hydrometers is entirely conventional, and they give neither the densities of the liquids nor the quantities dissolved. But they are very useful in making mixtures or solutions in given proportions and in evaporating acids, alkaline liquids, solutions of salts, worts, syrups, and the like to a proper degree of concentration, the results they give being sufficiently exact in the majority of cases.



Fig. 106

126. **Gay-Lussac's alcoholometer.**—This instrument is used to determine the strength of spirituous liquors; that is, the proportion of pure alcohol which they contain. It differs from Baumé's hydrometer in the graduation.

The alcoholometer is so constructed that, when placed in pure distilled water, the bottom of its stem is level with the water, and this point is zero. It is next placed in absolute alcohol, which marks 100°, and then successively in mixtures of alcohol and water containing 10, 20, 30, &c., per cent. The divisions thus obtained are not exactly equal, but their difference is not great, and they are subdivided into ten divisions, each of which marks *one* per cent. of absolute alcohol in a liquid. Thus a brandy in which the alcoholometer stood at 48° would contain 48 per cent. of absolute alcohol, and the rest would be water.

All these determinations are made at 15° C., and for that temperature only are the indications correct. For, other things being the same, if the temperature rises the liquid expands, and the alcoholometer will sink, and the contrary if the temperature fall. To obviate this error, Gay-Lussac constructed a table which for each percentage of alcohol gives the reading of the instrument for each degree of temperature from 0° up to 30°. When the exact analysis of an alcoholic mixture is to be made, the temperature of the liquid is first determined, and then the point to which the alcoholometer sinks in it. The number in the table corresponding to these data indicates the percentage of alcohol. From its giving the percentage of alcohol, this is often called the *centesimal alcoholometer*.

127. **Direct reading hydrometer.**—The most commonly used form of constant weight hydrometer is similar in appearance to Fahrenheit's and is shown in fig. 107. It consists of a narrow glass stem attached to a cylindrical

bulb weighted by a smaller bulb filled with shot or mercury so as to float in a vertical position. The stem is graduated in such a way that when the instrument is immersed in a liquid, the graduation, which is on a level with the surface of the liquid, gives the specific gravity directly. The instrument shown in the figure is intended for a liquid whose specific gravity lies between 1.0 and 1.2. When placed in distilled water it sinks to the mark 1000. If the graduation 1117 is level with the surface when the instrument floats in (say) dilute acid, the specific gravity of the acid is 1.117. These hydrometers are supplied in sets of 5, giving a range of specific gravities from .7 to 1.9.

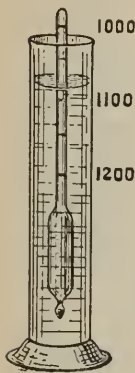

Fig. 107

128. **Salimeters.**—*Salimeters*, or instruments for indicating the percentage of a salt contained in a solution, are made on the principle of the centesimal alcoholometer. They are graduated by immersing them in pure water, which gives the zero, and then in solutions containing different percentages of the salt, and marking on the scale the corresponding points. These instruments are open to the objection that every salt requires a special instrument. Thus one graduated for common salt would give false indications in a solution of nitre.

Lactometers are similar instruments, and are based on the fact that the average density of a good natural quality of milk is 1.029. Hence if water is added to milk, it will indicate a lower specific gravity. But a common plan of adulteration is to remove cream from the milk, by which its specific gravity is increased, and then add water so as to reproduce the original density; the lactometer will not reveal a fraud of this kind. *Urinometers* are frequently used in medicine to test the variations in the density of urine which accompany and characterise certain forms of disease.

129. **Densimeter.**—*Rousseau's densimeter* (fig. 108) is of great use in many scientific investigations, in determining the specific gravity of a small quantity of a liquid. It has the same form as Beaumé's hydrometer, but there is a small tube AC at the top of the stem, in which is placed the substance to be determined. A mark, A, on the side of the tube indicates a measure of a cubic centimetre.

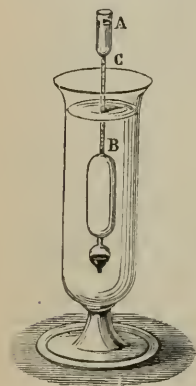

Fig. 108

The instrument is so constructed that when AC is empty it sinks in distilled water to a point, B, just at the bottom of the stem. It is then filled with distilled water to the height measured on the tube AC, which indicates a cubic centimetre, and the point to which it now sinks is marked 20. The interval between 0 and 20 is divided into 20 equal parts, and this graduation is continued to the top of the scale. As this is of uniform bore, each division corresponds to $\frac{1}{20}$ gramme, or 0.05.

To obtain the density of any liquid—bile, for example—the tube is filled with it up to the mark A; if the densimeter sinks to 20 divisions, its weight is $0.05 \times 20.5 = 1.025$; that is to say, with equal volumes, the weight of water being 1, that of bile is 1.025. The specific gravity of bile is therefore 1.025.

CHAPTER II

CAPILLARITY, ENDOSMOSE, DIFFUSION, AND ABSORPTION

130. **Capillary phenomena.**—When solid bodies are placed in contact with liquids, phenomena are produced which are classed under the general head of *capillary phenomena*, because they are best seen in tubes whose diameters are so small as to be comparable with that of a hair. These phenomena are treated of in Physics under the head of *capillarity* or *capillary attraction*; the latter expression is also applied to the force which produces the phenomena.

When a body is placed in a liquid which wets it—for example, a glass rod in water—the liquid, as if not subject to the action of gravitation, is raised upwards against the sides of the solid, and its surface, instead of being horizontal, becomes slightly concave (fig. 109). If, on the contrary, the solid is one which is not moistened by the liquid, as glass by mercury, the liquid is depressed against the sides of the solid, and assumes a convex shape, as represented in fig. 110. The surface of the liquid exhibits the same concavity

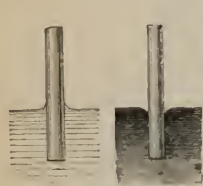

Fig. 109



Fig. 110



Fig. 111

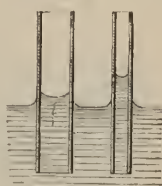

Fig. 112

or convexity against the sides of a vessel in which it is contained, according as the sides are or are not moistened by the liquid.

These phenomena are much more marked when a tube of small diameter is placed in a liquid. And according as the tubes are or are not moistened by the liquid an ascent or a depression of the liquid is produced which is greater in proportion as the diameter is less (figs. 111 and 112).

When the tubes are moistened by the liquid, its surface assumes the form of a concave hemispherical segment, called the *concave meniscus* (fig. 112); when the tubes are not moistened, there is a *convex meniscus* (fig. 111).

131. **Laws of the ascent and depression of liquids in capillary tubes.**—The most important law in reference to capillarity is known as *Jurin's law*. It is: *For the same liquid and the same temperature, the mean height of the*

ascent in a capillary glass tube is inversely as the diameter of the tube. Thus, if water rises to a height of 30 mm. in a tube 1 mm. in diameter, it will only rise to a height of 15 mm. in a tube 2 mm. in diameter, but to a height of 300 mm. in a tube 0.1 mm. in diameter. This law has been verified with tubes whose diameters ranged from 5 mm. to 0.07 mm. It presupposes that the liquid has previously moistened the tube.

The *mean height* is the height of a cylinder with a circular base which has exactly the same volume as the liquid column raised. If h is this height and $2r$ the diameter of the tube, Jurin's law may be expressed by the equation

$$rh = \text{const.}$$

For various liquids, and the same temperature, the mean heights raised in capillary glass tubes of the same diameter vary with the nature of the liquid. Of all liquids water rises the highest; thus in a glass tube 1.29 mm. in diameter, the heights of water, alcohol, and turpentine are respectively 23.16, 9.18, and 9.85 mm.

For the same liquid, and the same temperature, the mean heights are independent of the form of the capillary tube. That is to say, the shape of the tube above or below the meniscus has no effect on the phenomenon.

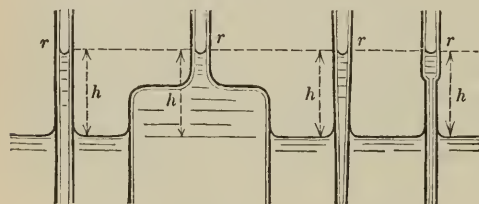

Fig. 113

The columns raised would be of very unequal weights, but of equal heights, h , in the tubes represented in fig. 113, all of which have the same diameter at the top of the liquid column. The value of r in the formula $rh = \text{const}$ is the radius of the tube in the region of the meniscus.

Provided the liquid moistens the tube, neither its thickness nor its nature has any influence on the height to which the liquid rises. Thus water rises to the same height in tubes of different kinds of glass, and of rock crystal, provided the diameters are the same.

The height to which a given liquid rises in a capillary tube diminishes as the temperature increases. Thus in a capillary tube in which water stood at a height of 30.7 mm. at 0° , it stood at 28.6 mm. at 35° , and at 26 mm. at 80° . This diminution of height is considerably greater than is accounted for by the diminished density of the water; for, while this is about 0.00045 for each degree between 0° and 100° , the mean diminution of the height is 0.00182, or about four times as much.

At the same time that the height becomes less the meniscus is flattened, so that above a certain temperature, which varies with different liquids, the capillary surface becomes flat and horizontal, and its level is that of the external liquid. Working in closed vessels, Wolff found this temperature to be 191° for ether and 500° for water.

In regard to the depression of liquids in tubes which they do not moisten, Jurin's law has not been found to hold with the same accuracy. The reason for this is probably to be found in the following circumstances:—When a liquid moistens a capillary tube, a very thin layer of liquid is formed

against the sides, and remains adherent even when the liquid sinks in the tube. The ascent of the column of liquid takes place then, as it were, inside a central tube, with which it is physically and chemically identical. The ascent of the liquid is thus an act of cohesion. It is therefore easy to understand why the nature of the sides of the capillary tube should be without influence on the height of the ascent, which only depends on the diameter.

With liquids, on the contrary, which do not moisten the sides of the tube, the capillary action takes place between the sides and the liquid. The nature and structure of the sides are never quite homogeneous, and there is always, moreover, a layer of air on the inside, which is not dissolved by the liquid. These two causes undoubtedly exert a disturbing influence on the law of Jurin.

The law of Jurin may be illustrated and verified for glass capillary tubes and liquids which wet them by the arrangement shown in fig. 114. The diameters of the tubes are measured by introducing a thread of mercury into them and ascertaining the weight of a given length. If P is

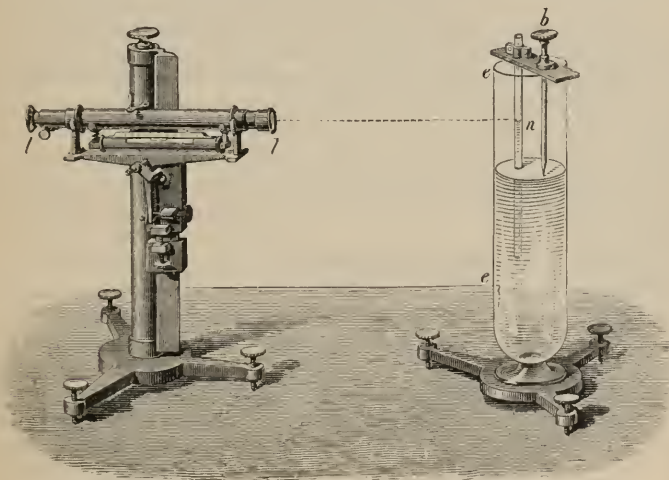

Fig. 114

the weight in grammes of a length l centimetres of mercury whose specific gravity at the temperature of the experiment is D , $P = \pi r^2 l D$, whence r is determined in centimetres.

The height to which the liquid rises in the capillary tube is read off by the cathetometer (87). The capillary tube is fixed to a cross piece of wood, which is placed on the edges of a glass vessel, ee , half filled with the liquid. In order that the liquid may properly moisten the tube it is sucked up by means of an india-rubber tube beyond the height at which it finally stands. The cathetometer telescope is then raised to the level H of the lowest point of the meniscus. The pointed screw b is then turned until its point just grazes the liquid, and the position of the point is read off. The difference of these

two readings gives the desired height. Determining thus the radii and capillary heights of different glass tubes, we may verify the constancy of the product $r\bar{h}$.

132. **Ascent and depression between parallel or inclined surfaces.**—When two bodies of any given shape are dipped in water, analogous phenomena are produced, provided the bodies are sufficiently near. If, for example, two parallel glass plates are immersed in water at a very small distance from each other, water will rise between the two plates in the inverse ratio of the distance which separates them. The height of the ascent for any given distance is half what it would be in a tube whose diameter is equal to the distance between the plates.

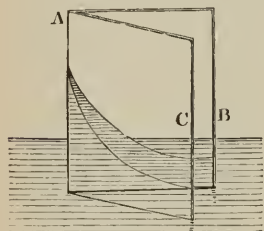

Fig. 115

If the parallel plates are immersed in mercury, a corresponding depression is produced, subject to the same laws. If two glass plates, AB and AC, with their planes vertical and inclined to each other at a small angle, as represented in fig. 115, have their ends dipped into a liquid which wets them, the liquid will rise between them. The elevation will be greatest at the line of contact of the plates, and from hence gradually less, the surface taking the form of an equilateral hyperbola.

A similar curve is obtained by dipping the inclined plates into mercury, the depression increasing towards the line of contact of the two plates. The best way of *seeing* this phenomenon is to use a prismatic glass cell of very small angle.

133. **Tension of the free surface of liquids.**—The great mobility which is characteristic of the liquid state undergoes an alteration in the neighbourhood of the *free surface* of a liquid, or that which is bounded by a gas or by a vacuum. For consider any particle, a , at the surface (fig. 116), and let the

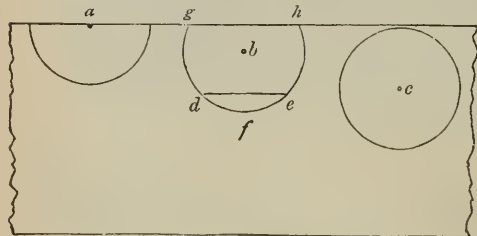

Fig. 116

sphere represent the range through which the molecular attraction is exerted, the radius of which is called the *radius of molecular action* (3). The attractive forces of the adjacent particles, which are exerted in all directions, may be resolved into horizontal and vertical components; the attractions of the former will compensate each other. But the attractions represented by the molecules within the hemisphere, beneath the surface, are not so compensated, and consequently the latter will exercise a considerable pull towards the interior.

Consider, again, a particle, b , so much below the surface that the greater part of the sphere comes into operation. If a plane, de , is drawn as much below b as the surface is above b , the attractive forces from the molecules

within *ghed* will neutralise each other. But the segment *def* remains uncompensated, and exerts a pull similar to, though weaker than, that which acts on the molecule *a*.

The molecule *c* finally is surrounded uniformly by its adjacent ones, and their resultant action is zero.

The effect of these actions is to lessen the mobility of particles at or very near the surface, while those in the interior are quite mobile; the surface, as it were, is stretched by an elastic skin, the result being the same as if the surface layer exerted a pressure on the interior.

An imaginary line drawn in the surface of a liquid may be supposed to be kept in equilibrium by equal and opposite forces, acting in the surface at right angles to the line. The magnitude of this force per unit of length of the line is called the *surface tension* of the liquid. The effect of surface tension is to reduce the area of the liquid surface to a minimum. If *T* represents the surface tension of a liquid, *Ta* will be the force acting perpendicularly to a line of length *a* in the surface, and thus we see that to stretch a rectangle whose sides are *a* and *b*, into another whose sides are *a* and *b* + *b'*, an amount of work equal to *Ta* × *b'* or *Tab'* is required. Thus *T* is numerically equal to the work which must be done upon a liquid surface to stretch its area by the unit amount. Similarly, when the surface is diminished, some molecules pass into the interior, and work is done by the liquid, its amount being numerically equal to *T* when the diminution in area is 1 sq. cm. Thus, *T* is the potential energy per unit of surface.

The existence of this surface tension may be illustrated by several interesting experiments. In that of Dupré (fig. 117), a quadrangular flat vessel, ABCD, is used, of which one side, CD, is movable about a hinge. By means of a string this side is pressed against a wedge, and the vessel is filled with water. On burning the string the side CD' reverts to its original position, CD. Now hydrostatic pressure would keep CD pressed against the wedge, but the surface tension, tending as it does to reduce the surface-area, overcomes the hydrostatic pressure and restores CD to the vertical position.



Fig. 117

Another experiment, due to Van der Mensbrugghe, is made by means of a wire frame (fig. 118), which is immersed in solution of soap, such as is used for blowing soap bubbles. On removal this carries a thin film with it. A loop of fine silk thread moistened with the liquid in question is carefully placed on the film, and assumes any shape (fig. 118 *a*). By means of a hot wire, the film is broken inside the loop, and the silk thread is then seen to stretch and assume a circular form (fig. 118 *b*). Before the film inside the loop was broken, the surface tension acted equally on both sides of the thread, but after its rupture the tension on the outer side of the

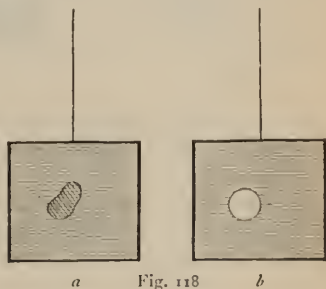

Fig. 118

thread was unbalanced, and, being equal in all directions, drew the thread into the circular form, rendering the remaining liquid surface as small as possible.

134. **Consequences of surface tension. Capillary pressure.**—The existence of a real force or tension acting in the surface of a liquid and tending to reduce the area of the free surface to a minimum may thus be regarded as proved experimentally. Surface tension gives rise to a pressure acting at right angles to the free surface, distinct altogether from hydrostatic pressure. The magnitude of this *capillary pressure* depends partly upon the surface tension and partly upon the curvature of the surface. It is expressed by the formula of Laplace

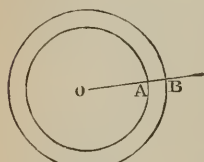

Fig. 119

$$p = T \left(\frac{1}{R_1} + \frac{1}{R_2} \right)$$

where T is the surface tension, R_1 R_2 the principal radii of curvature of the liquid surface at the point considered. If the surface is spherical, $R_1 = R_2$ and $p = 2T/R$. The capillary pressure is always directed towards the concave side of the surface. Hence for a spherical soap bubble, the internal radius OA (fig. 119) is R , and its thickness $AB = d$, the pressure due to the outer layer is $2T/(R + d)$, and to the inner layer $2T/R$: thus the total pressure, directed inwards, is $2T/R + 2T/(R + d)$ or $4T/R$, since d may be neglected in comparison with R . This is well illustrated by blowing a soap bubble on a glass tube. So long as the other end of the tube is closed, the bubble remains, the elastic force of the enclosed air counterbalancing the capillary pressure; but when the tube is opened, the pressure due to the surface tension being unbalanced, the bubble gradually contracts and finally disappears. As a direct consequence of the pressure due to surface tension may be cited the motion of the liquid in a horizontal tapering tube. If a drop of water is placed in a conical glass tube whose angle is small and axis horizontal, it will have a concave meniscus at each end (fig. 120); therefore the capillary pressure at each end will be



Fig. 120



Fig. 121

directed outwards. But since the pressure is inversely proportional to the radius of curvature, there will be a resultant pressure towards the fine end of the tube, and the liquid therefore will move in this direction. But if the drop is of mercury, it will have a convex meniscus at each end (fig. 121), and will move towards the wider part of the tube. The force causing motion depends upon the difference of the curvatures of the liquid free surfaces, and may be considerable, as is shown by placing vertically a wide glass tube, the lower end of which is drawn out into a very fine capillary termination, and introducing mercury at the other end. A mercury column 1 metre long may thus be easily supported, its downward hydrostatic pressure being balanced by the upward capillary pressure at the surface of the mercury in the fine part of the tube.

If water is gently poured into a glass tube similar to that shown in fig. 122 *a*, we shall find that, supposing all parts of the tube to have been

previously wetted, when the water stands at any point *a* in the larger tube it will be at a higher point *a'* in the smaller, both free surfaces being concave upwards. When more water is poured in, the level in the fine tube rises, reaches the top, and remains there until overtaken by the liquid in the wide tube. During this time no liquid has escaped, but the curvature has gradually diminished in the fine tube, so that when the same level is attained the liquid surface is plane (fig. 122 *b*). The effect of adding still more water is to convert the plane into a convex surface, and the direction of the capillary pressure is downwards. Thus water may be poured into the larger tube until its level is considerably above the top of the fine tube, without any escape of liquid (fig. 122 *c*).

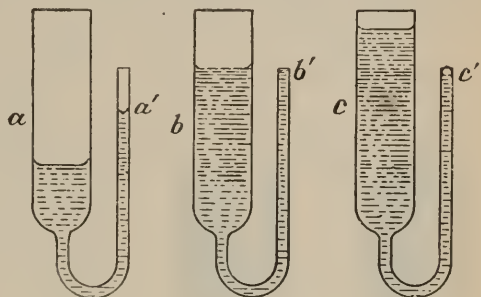

Fig. 122

Insects can often move on the surface of water without sinking. This phenomenon is caused by

the fact that, as their feet are not wetted by the water, a depression is produced, and the elastic reaction of the surface layer keeps them up in spite of their weight. Similarly, a sewing-needle, gently placed on water, does not sink, because its surface, being covered with an oily layer, does not become wetted. The pressure of the needle brings about a concavity, the surface tension of which acts in opposition to the weight of the needle. But if washed in alcohol or in potash, the metal is wetted and at once sinks to the bottom.

Among the phenomena due to surface tension may be mentioned the well-known one of the 'tears of wine.' The surface tension of water in contact with air is greater than that of any other liquid except mercury. It is nearly three times as great as that of alcohol. When a wine-glass is half filled with a strong wine, the wine rises up against the sides like any other liquid; but the alcohol evaporates rapidly from the surface, the consequence of which is that the liquid layer becomes more and more watery. Near the surface of the liquid the strength of the liquid layer is kept up by diffusion; but higher up owing to the increased surface tension of the more aqueous wine, it creeps up the sides and draws with it some of the stronger alcoholic liquid below, the increasing weight of which ultimately causes it to break and run down in drops.

If a thin layer of water is spread on a plate, and a drop of ether is placed upon it, the water retreats from the drop. Here, instead of the surface tension between water and air, we have that between water and ether, which is smaller; the effect is much the same as if there were a tightly stretched india-rubber skin over the water surface, and a portion of it were softened or made thinner.

135. **Contact of liquids and solids. Angle of contact.**—It has been seen that the particles in and close to the surface of a liquid, *A*, are subject to

molecular forces different from those experienced by particles in the interior, and that surface tension is a consequence of this difference. The effect of placing more of the same liquid, B, on the surface of A would be to destroy the surface tension, since the surface is destroyed. The tangential action of the added liquid B on the surface layer of A is equal to $-T$, where T is the surface tension. If, instead of adding more of the same liquid, we place in contact with A another body, B, either liquid or solid, the tangential action of B upon A will similarly be a certain force, $-T'$, and the tension in the surface of contact will become $T - T'$. Thus in contact with another liquid, or a solid,

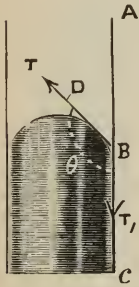

Fig. 123

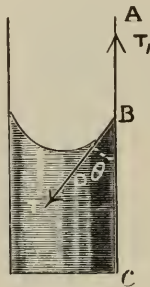

Fig. 124

B, the surface tension in A is $T - T'$.

Suppose the body B to be a solid, e.g. a glass tube, and first let the liquid be one which does not wet glass, as mercury. Let T_1 be the surface tension between glass and mercury. According to the nature of the substances in contact, T_1 may be positive or negative; with glass and mercury it is positive. Consider a molecule at B (fig. 123); since its weight may be neglected in comparison with the

molecular forces which act upon it, this molecule is solicited by two forces only, T acting tangential to the liquid, and T_1 along the tube. For equilibrium, T_1 must be equal to the resolved part of T upwards, or $T_1 = -T \cos \theta$, θ being the angle DBC of the wedge of liquid formed by the tangent BD ,

$$\therefore \cos \theta = -T_1/T.$$

Since T is always positive, θ is obtuse when T_1 is positive, and (fig. 124) acute when T_1 is negative. The latter condition holds when the liquid wets the tube. With glass and water under proper conditions θ is very small and may be taken $= 0$ without sensible error.

With regard to the angle of contact when there is no wetting, theory indicates that it should be constant for the same liquid and the same solid; and experiments made by Gay-Lussac seemed to confirm the theory, at least where mercury and glass are concerned. More recent and precise experiments by Quincke

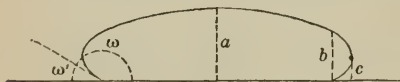

Fig. 125

have thrown doubt on the accuracy of Gay-Lussac's conclusions. Quincke determined by an optical method the angle of contact of different drops of mercury placed on the same plate of glass. In addition, by measuring three ordinates of the surface, viz. a , the maximum ordinate (fig. 125) b , the ordinate of the extreme point of contact, and c , the ordinate at the edge of the drop, he was enabled to determine the form of the surface. Quincke found that there is a continuous change in the form of drops, very rapid when the drop is first placed on the glass, then slower, but without having

ceased even at the end of several days, and further that there is a continuous change in the magnitude of the angle of contact. It follows from this that, for a drop of mercury resting on a glass plate, capillary equilibrium is never complete or stable. Numerous observations (by Bravais and by Quincke) have shown that the same statement is true with regard to columns of mercury, rising or falling, in glass tubes, although here friction may establish an apparent equilibrium, which however is but momentary.

The angle of contact is not then constant for the same solid and liquid. Thus for mercury and glass it varies, without apparent reason, between 135° and 142° . The variation is much greater when there is an apparent cause, such as the interposition of a very thin layer of a foreign substance between the liquid and the solid in contact.

136. Various capillary phenomena.—The attractions and repulsions observed between bodies floating on the surface of liquids find their explanation in the concave or convex curvature which the liquid assumes in contact with the solid. The following are some of them.

When two floating balls both moistened by the liquid—for example, cork upon water—are so near that the liquid surface between them is not level, an attraction takes place. The same effect is produced when neither of the balls is moistened, as is the case with balls of wax on water.

Lastly, if one of the balls is moistened and the other not, as a ball of cork and a ball of wax in water, they repel each other if the curved surfaces of the liquid in their respective neighbourhoods intersect.

A drop of mercury on a table has a shape which is the more nearly spherical the smaller the drop. The smaller the mass of a liquid the greater is the surface in comparison with the weight; the less, therefore, is the action of gravity in comparison with that of the surface tension; hence the smaller the globule the nearer it is to a perfect sphere; if the quantity of mercury is much greater, the globule flattens, but always remains convex at its edge. The spherical or quasi-spherical form is due to the action of surface tension, which constrains the liquid to present the least possible surface; and the surface of a sphere is less than that of any other figure having the same volume. A liquid immersed in another, with which it does not mix, of exactly the same specific gravity, such as olive oil in a mixture of alcohol and water, assumes the spherical form (fig. 4).

To this cause also is due the spherical form acquired by small masses of liquid which fall through great heights, such as raindrops, and molten lead in the manufacture of small shot.

When a capillary tube is immersed in a liquid which moistens it, and is then carefully removed, the column of liquid in the tube is seen to be twice as long as while the tube was immersed in the liquid. This arises from the fact that a drop adheres to the lower extremity of the tube and forms a convex meniscus, which concurs with that of the upper meniscus to form a longer column since the pressure at the convex surface will drive the liquid up the tube.

It is from capillarity that oil ascends in the wicks of lamps, that water rises in woods, sponge, bibulous paper, sugar, sand, and in all bodies which possess pores of a perceptible size. In the cells of plants the sap rises with great force, for here we have to do with vessels whose diameter is less than

0.01 mm. Efflorescence of salts is also due to capillarity; a solution rising against the side of a vessel, the water evaporates, and the salt forms on the side a means of furthering still more the ascent of a liquid. Capillarity is, moreover, the cause of the following phenomenon:—When a porous substance, such as gypsum, or chalk, or even earth, is placed in a porous vessel of unbaked porcelain, and the whole is dipped in water, the water penetrates into the pores, and the air is driven inwards, with such force that it is under four or five times its usual pressure and density. Jamin has proved this by cementing a manometer into blocks of chalk, gypsum, &c., and he has made it probable that a pressure of this kind, exerted upon the roots, promotes the ascent of sap in plants.

Capillarity is thus one of the most widely diffused and important natural phenomena.

137. **Determination of surface tension or the constant of capillarity.**—This determination may be effected in various ways, of which the simplest and perhaps the most accurate is that of the measuring the ascent of a liquid in capillary tubes. Suppose the radius of the tube to be r , ρ the density of the liquid, θ its angle of contact, T the tension of the surface film, and h the mean height to which it is elevated. Then the vertical component of the whole tension round the edge of the film is $2\pi rT \cos \theta$. But this supports the weight $\pi r^2 h g \rho$ of liquid which fills a mean length h of the tube. Equating these quantities, we readily obtain $T = \frac{1}{2} h r \rho g / \cos \theta$. When θ is greater than 90° , h is negative, and the liquid is depressed. The radius of the tube is determined by introducing a thread of mercury into the tube and ascertaining the weight of a given length; h is measured by a cathetometer (131), and ρ and g are known. Hence T is determined if θ can be found by a separate process. In the case of water in glass $\theta = 0$, and $\cos \theta = 1$, so that the above relation gives T directly.

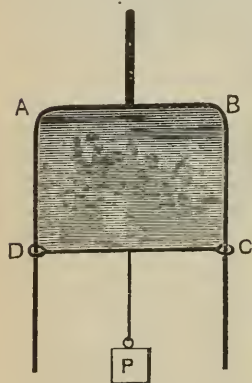

Fig. 126

The principle of another method of determining this constant is represented in fig. 126. The parallel limbs of a thin iron wire $DABC$ are connected by a cross wire DC with two loops. If DC is brought near AB and some soap solution added, a thin film of liquid forms when CD is left to itself. By gradually adding weights, P , a point is reached at which the total weight of CD and P just counterbalances the tension of the liquid film; when the weight P is removed the film contracts, while if the weight is sufficiently increased the film breaks.

If P , in this experiment, represents the total weight in grammes, and $DC = b$ cm., the surface tension in grammes-weight per linear centimetre is

$$T = \frac{P}{2b}$$

seeing that the surface tension acts on both sides of the film.

When two fluids are in contact the surface tension between them depends on the nature of the fluids; in the case of water, for instance, it differs according as this is bounded by air or by oil.

The surface tension between two liquids 1 and 2 we denote by T_{12} . The following table (mainly from Quincke) gives the value of the surface tension for a few cases in grammes-weight per centimetre.

Mercury	—Air	. 0.55	Mercury	—Olive oil	. 0.342
Water	— „	. 0.075	Olive oil	—Water	. 0.021
Olive oil	— „	. 0.038	Turpentine	— „	. 0.012
Chloroform	— „	. 0.031			
Turpentine	— „	. 0.030			
Alcohol	— „	. 0.026			
Ether	— „	. 0.018			
Liquid air	— „	. 0.015			
Liquid Hydrogen	— „	. 0.002			

If there are several surfaces of separation, the formation of that with the smallest tension is promoted. Thus if a drop of olive oil is placed on water (fig. 127), as represented by 3, then at the edge of the drop the three fluids, air, water, and oil, coincide, and three surface tensions act which are proportional to T_{13} , T_{23} , T_{12} . Now from the table $T_{12} = 0.075$, $T_{13} = 0.038$, and $T_{23} = 0.021$; therefore $T_{12} > T_{13} + T_{23}$, and the two forces T_{13} and T_{23} cannot counterbalance the force T_{12} , and the oil spreads until the whole surface is covered with a thin layer of oil. Although oil *is spread* over water by the pull T_{12} , it is usual to say that oil spreads itself on water. The extension of the oil over the surface of the water will take place rapidly if the liquids are pure and the surfaces clean; otherwise the oil will maintain for a time a lens-like form, and will spread only slowly over the water.

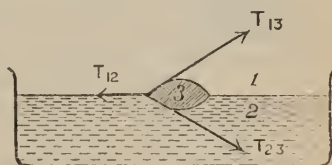

Fig. 127

That surface tension is only exhibited at the boundary of two liquids is well seen by an experiment of Professor Boys:—If a camel's-hair brush is dry the hairs are separately visible, and to make them come to a point they must be wetted; this adherence is not due to moisture, for if the pencil is wholly immersed in water the separate hairs are as visible as when the pencil is dry.

138. Formation of drops in a capillary orifice.

—When a liquid is contained in a vessel terminating in a narrow capillary opening, such as a *dropping tube*, a certain excess of pressure is required to make the liquid flow out. If this pressure is limited, the lower meniscus has an invariable shape, and the drop does not increase. But as the pressure increases the drop gradually expands like a small elastic bag, the tension of which is less in the degree in which the surface increases, and when the drop is so large that its weight exceeds the vertical component of the surface tension, it contracts at the upper part, and finally breaks across a circumference $\sigma' \sigma'$, which is nearly equal to that of the orifice $\sigma \sigma$.

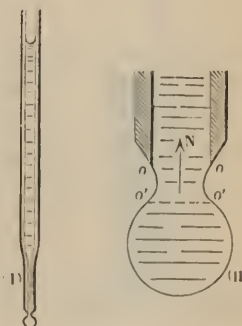

Fig. 128

Tate has found that *the weights of drops formed with different capillary tubes are for the same liquid proportional to the diameters of the orifice.*

The weights of the drops are independent of the substance of the tube, provided it is moistened; they diminish with rise of temperature.

When a small but very hot flame is directed against the point of a fine metal wire, such as gold or platinum, the metal is melted and falls in drops, the weight P of which is found to be very uniform. P is the greatest weight which the melted mass can support, and is equal to $2\pi rT$, where T is the constant of capillarity and $2r$ the diameter of the wire. Quincke has applied this method of determining the constant in cases where other methods are not applicable, such as in the case of the noble metals, salts, selenium, phosphorus, &c.

139. **Osmose.**—Other phenomena are observed when two different liquids miscible with each other are separated by a porous diaphragm. This may be best illustrated by means of the apparatus represented in fig. 129, in which a vessel, b , open at the bottom, is tied round with a bladder. In the neck a long narrow tube, $a a$, is fitted. This vessel is filled with solution of copper sulphate, so that it stands at a certain height, r , in the tube, and is then placed in a larger vessel containing pure water, at the level $n n$. If the temperature remains stationary, it will be seen that after some time the liquid in the tube $a a$, which was originally at the level r , has risen, while the level of $n n$ has become somewhat lower; it will also be seen that the outer liquid has acquired a faint bluish tinge. This process continues for some time until the liquid has attained a certain height. It thus appears that there is an interchange of the two liquids, but the quantity of water which passes into the sulphate of copper is greater than that of the solution which passes out. If the experiment is reversed—that is, if water is contained in b , and copper sulphate in the outer vessel—the phenomena are reversed; that is, the level in r sinks, while that in $n n$ rises. Dutrochet, who first investigated these phenomena, applied the term *exosmose* to the current which passes from the denser liquid to the less dense, and *endosmose* to the opposite current, and the apparatus itself he called an *endosmometer*. The phenomena are now known as those of *diosmose* or *osmose*.

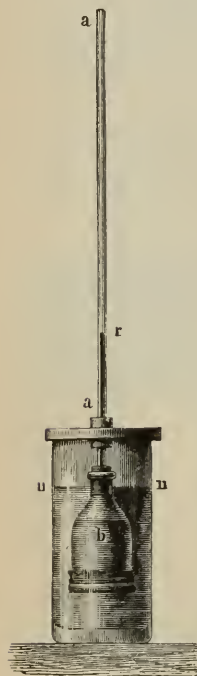

Fig. 129

For the occurrence of osmose the membrane must be permeable to at least one of the liquids, and the liquids must be different, but capable of mixing, such as alcohol and water; there is none, for instance, between water and oil. Osmose may occur between two liquids of the same kind, but of different densities, such as solutions of acids or salts of different strengths; here the current is from the weaker towards the stronger solution, and this is general, osmose usually taking place towards the denser liquid. Alcohol and ether form an exception; although they are specifi-

cally lighter than water, they behave in this respect like liquids which are denser.

If a tube filled with water is closed at both ends by a bladder (fig. 130), and one end is placed in a vessel of water, the other being in contact with the air, the water gradually evaporates through the bladder; it is, however, as rapidly replaced, so that, in consequence of evaporation, water moves through the tube towards the outer end. Hence osmose plays a part in the motion. The evaporation from the skin of animals brings about a motion of liquids from the interior towards the evaporating surface. In like manner, the passage of water to the rootlets of plants, as well as the ascent of sap to the highest points of the trees, is favoured by evaporation from branchlets, leaves, flowers, and fruit.

The well-known fact that dilute alcohol kept in a porous vessel becomes concentrated depends on osmose. If a mixture of alcohol and water is kept for some time in a bladder, the volume diminishes, but the alcohol becomes much more concentrated. The reason doubtless is that the bladder absorbs water more readily than alcohol, and accordingly water evaporates on the surface, and thus brings about a concentration of the residue.



Fig. 130

Dutrochet's method is not adapted for quantitative measurements, for it does not take into account the hydrostatic pressure produced by the column. Jolly examined the endosmose of various liquids by determining the weights of the bodies diffused. He called the *endosmotic equivalent* of a substance the number which expresses how many parts by weight of water pass through the bladder in exchange for one part by weight of the substance. The following are some of the endosmotic equivalents which he determined:—

Sulphuric acid	0.4	Copper sulphate	9.5
Alcohol	4.2	Magnesium sulphate	11.7
Sodium chloride	4.3	Caustic potash	215.0
Sugar	7.1		

He also found that the endosmotic equivalent increases with the temperature, and that the quantities of substances which pass in equal times through the bladder are proportional to the strengths of the solutions.

Porous diaphragms differ very greatly in the facility with which they permit osmose; of all substances, goldbeater's skin is the best, being twice as good as vegetables, and sixty or seventy times as good as porous earthenware, which, however, is necessary in some cases, for organic membranes are apt to decompose.

Pfeffer has constructed what he calls *semi-permeable membranes*, by immersing a porous cell, such as is used for voltaic batteries, in solution of copper sulphate, and then in one of ferrocyanide of potassium. By double decomposition, a coherent layer of ferrocyanide of copper is formed, which is permeable to the molecules of water, but not to those, for instance, of sugar. If a solution of sugar contained in such a vessel is immersed in water, pure water filters through; the membrane acts as a *molecular sieve*.

The whole phenomena and laws of osmose have, in recent times, acquired great importance from the theoretical considerations of Van 't Hoff on the nature of solutions, of which we may indicate the general results.

If a one-per-cent. solution of sugar is placed in the vessel in such an arrangement as that represented by *b* in fig. 129, when the semi-permeable diaphragm is of ferrocyanide of copper, since the diaphragm is permeable to water but not to sugar, the quantity of liquid in *b* increases and rises in the tube to a height of 53·5 cm. ; when the pressure due to the water is the same on both sides the diaphragm, this height is a measure of the *osmotic pressure* due to the sugar. Dealing with dilute solutions, it is found that this pressure is proportional to the concentration ; thus, with solutions of 1, 2, 4, and 6 per cent. respectively, the corresponding osmotic pressures are 53·5, 101·6, 208·2, and 307·5 respectively. We shall afterwards see (294) that we conceive a mass of gas as made up of a very large number of molecules moving in all directions with extreme velocity, and that the pressure of a gas is due to the impacts of these molecules against the sides of the containing vessel. Now in what are called *ideal solutions*—those, that is to say, in which the dimensions of the molecules (3) of the body dissolved may be disregarded in comparison with the space in which they are contained—Van 't Hoff considers that the molecules of the body dissolved are animated by just such a motion as they possess in the case of gases.

If the pressure on a given volume of gas is gradually increased its volume will be diminished, and it is found that to reduce it to one-half, the temperature remaining constant, the original pressure must be doubled. For a given mass of gas, the product of pressure and volume is constant ; this is what is known as Boyle's law (181). Osmotic pressure in liquids is exactly analogous to the pressure of gases ; if we double the number of molecules in a given volume of liquid, we double the pressure, just as we can force two volumes of gas into the space occupied by one if we double the pressure. This analogy between osmotic and gaseous pressure is not a fanciful one, but holds good in details so far as it has been tried. It can be shown, for instance, that the osmotic pressure of sugar in solution is the same as would be exerted by the same weight of sugar if it existed in the state of gas in the same space as that occupied by the solution.

Gases, as will afterwards be shown, expand by a certain definite proportion of their volume when heated, the pressure remaining constant ; or, if the volume is kept constant, the increase of pressure is proportional to the increase of temperature. This is also found to hold with the osmotic pressure ; it increases in direct proportion to the temperature.

140. **Diffusion of liquids.**—If oil is poured on water, no tendency to intermix is observed, and even if the two liquids are violently agitated together, two separate layers are formed on allowing them to stand. With alcohol and water the case is different ; if alcohol, which is specifically lighter, is carefully poured upon water, so as to form two distinct layers, it will be seen that the heavier water rises in opposition to gravity into the lighter alcohol, which, in turn, passes into the denser liquid below ; the liquids gradually intermix, in spite of the difference of the specific gravities ; they *diffuse* into one another.

This point may be illustrated by the experiment represented in fig. 131. A tall jar contains water coloured by solution of blue litmus; by means of a funnel some dilute sulphuric acid is carefully poured in, so as to form a layer at the bottom; the colour of the solution is changed into red, progressing upwards, and after forty-eight hours the change is complete—a result of the action of the acid, and a proof, therefore, that it has diffused throughout the entire mass.

The laws of this diffusion, in which no porous diaphragm is used, were completely investigated by Graham. The method by which his latest experiments were made was the following:—A small wide-necked bottle, A (fig. 132), filled with the liquid whose rate of diffusion was to be examined, was closed by a thin glass disc and placed in a larger vessel, B, in which water was poured to a height of about an inch above the top of the bottle. The disc was carefully removed, and then after a given time successive layers were carefully drawn off by means of a siphon or pipette, and their contents examined.



Fig. 131

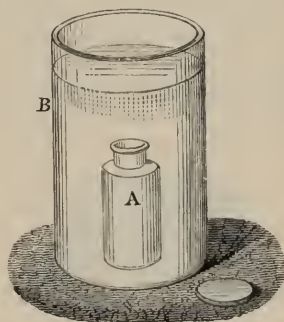

Fig. 132

The general results of these investigations may be thus stated:—

i. When solutions of the same substance, but of different strengths, are taken, the quantities diffused in equal times are proportional to the strengths of the solutions.

ii. In the case of solutions containing equal weights of different substances, the quantities diffused vary with the nature of the substances. Saline substances may be divided into a number of *equidiffusive groups*, the rates of diffusion of each group being connected with the others by a simple numerical relation.

iii. The quantity diffused varies with the temperature. Thus, taking the rate of diffusion of hydrochloric acid at 15° C. as unity, at 49° C. it is 2.18.

iv. If two substances which do not combine are mixed in solution, they may be partially separated by diffusion, the more diffusive one passing out most rapidly. In some cases chemical decomposition even may be effected by diffusion. Thus, potassium bisulphate is decomposed into free sulphuric acid and neutral sulphate.

v. If liquids are dilute, a substance will diffuse into water containing another substance dissolved, as it would into pure water ; but the rate is materially reduced if a portion of the same diffusing substance is already present.

The following table gives the approximate times of equal diffusion :—

Hydrochloric acid	1'0	Magnesium sulphate	7'0
Sodium chloride	2'3	Albumen	49'0
Sugar	7'0	Caramel	98'0

It will be seen from the above table that the difference between the rates of diffusion is very great. Thus magnesium sulphate, one of the least diffusible saline substances, diffuses 7 times as rapidly as albumen and 14 times as rapidly as caramel. These last substances, like hydrated silicic acid, starch, dextrine, gum, &c., constitute a class of substances which are characterised by their incapacity for taking the crystalline form, and by the mucilaginous character of their hydrates. Considering gelatine as the type of this class, Graham called them *colloids* (κόλλα, glue), in contradistinction to the far more easily diffusible *crystalloid* substances. Colloids are for the most part bodies of high molecular weight, and it is probably the larger size of their molecules which hinders their passing through minute apertures.

Graham devised a method of separating bodies based on their unequal diffusibility, which he called *dialysis*. His *dialyser* (fig. 133) consists of a

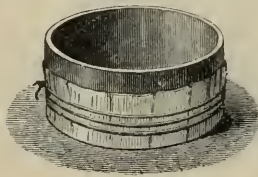

Fig. 133

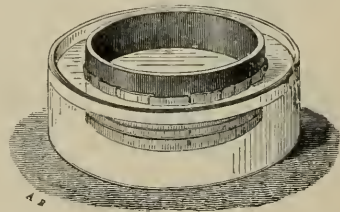

Fig. 134

ring of gutta-percha, over which is stretched while wet a sheet of parchment paper, forming thus a vessel about two inches high and ten inches in diameter, the bottom of which is of parchment paper. After pouring in the mixed solution to be dialysed, the whole is floated on a vessel containing a very large quantity of water (fig. 134). In the course of one or two days a more or less complete separation will have been effected. Thus a solution of arsenious acid mixed with various kinds of food readily diffuses out. The process has received important applications to laboratory and pharmaceutical purposes.

CHAPTER III

HYDRODYNAMICS

141. **Hydrodynamics.**—The science which treats of the motion of liquids is called *hydrodynamics*; and the application of the principles of this science to conducting and raising water in pipes and to the use of water as a motive power is known by the name of *hydraulics*.

142. **Velocity of efflux. Torricelli's theorem.**—Let us imagine an aperture made in the bottom of any vessel, and consider the case of a particle of liquid on the surface, without reference to those which are beneath. If this particle fell freely, it would have a velocity on reaching the orifice equal to that of any other body falling through the distance between the level of the liquid and the orifice. This, from the laws of falling bodies, is $\sqrt{2gh}$, in which g is the acceleration due to gravity, and h the height. If the liquid is maintained at the same level, for instance, by a stream of water running into the vessel, sufficient to replace what has escaped, the particles will follow one another with the same velocity, and will issue in the form of a stream.

The law of the velocity of efflux was discovered by Torricelli. It may be stated as follows:—*The velocity of efflux is the velocity which a freely falling body would have on reaching the orifice after having started from a state of rest at the surface.* It is expressed by the formula $v = \sqrt{2gh}$.

It follows directly from this law that the velocity of efflux depends on the depth of the orifice below the surface, and not on the nature of the liquid. Through orifices of equal size and of the same depth, water and mercury would issue with the same velocity; for although the density of the latter liquid is greater, the weight of the column, and consequently the pressure, are greater too. It follows further that the velocities of efflux are directly proportional to the square roots of the depth of the orifices. Water could issue from an orifice ten inches below the surface with ten times the velocity with which it would issue from one an inch below the surface.

The quantities of water which issue from orifices of different areas are very nearly proportional to the size of the orifice, provided the level remains constant.

143. **Direction of the jet from lateral orifices.**—From the principle of the equal transmission of pressure, water issues from an orifice in the side of a vessel with the same velocity as from an aperture in the bottom of a vessel at the same depth. Each particle of a jet issuing from the side of a vessel begins to move horizontally with the velocity above mentioned, but it is at once drawn downward by the force of gravity in the same manner as a

bullet fired from a gun, with its barrel horizontal. It is well known that the bullet describes a parabola (53) with a vertical axis, the vertex being the muzzle of the gun. Now, since each particle of jet moves in the same curve, the jet itself takes the parabolic form.

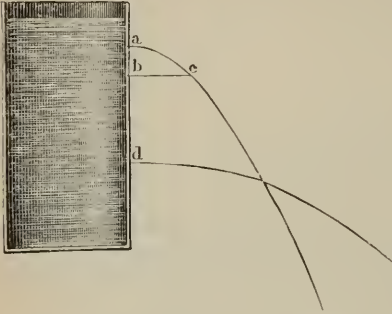

Fig. 135

are small in comparison with the dimensions of the vessel, the jets from orifices at different depths below the surface take different forms, as shown in fig. 135. If these are traced on paper held behind the jet, then, knowing the horizontal and vertical distances of any point of the jet from the orifice, it is easy to demonstrate that the jet forms a parabola.

144. Height of the jet.—If a jet issuing from an orifice in a vertical direction has the same velocity as a body would have which fell from the surface of the liquid to that orifice, the jet ought to rise to the level of the liquid. It does not, however, reach this; for the particles which fall hinder it. But by inclining the jet at a small angle with the vertical it reaches about $\frac{9}{10}$ of the theoretical height, the difference being due to friction and to the resistance of the air. By experiments of this nature the truth of Torricelli's law has been demonstrated.

145. Quantity of efflux. Vena contracta.—If we suppose the sides of a vessel containing water to be thin, and the orifice to be a small circle whose area is A , we might think that the quantity of water, E , discharged in a second would be given by the expression $A\sqrt{2gh}$, since each particle has, on the average, a velocity equal to $\sqrt{2gh}$, and particles issue from each point of the orifice. But this is by no means the case. This may be explained by reference to fig. 136, in which AB represents an orifice in the bottom of a vessel—what is true in this case being equally true of an orifice in the side of the vessel. Every particle above AB endeavours to pass out of the vessel, and in so doing exerts a pressure on those near it. Those that issue near A and B exert pressures in the directions MM and NN ; those in the centre of the orifice in the direction RQ ; those in the intermediate parts in the directions PQP . In consequence, the water within the space PQP is unable to escape, and that which does escape, instead of assuming a cylindrical form, at first contracts, and takes the form of a truncated cone. It is found that the escaping jet continues to contract until at a distance from the orifice about equal to the diameter of the orifice.

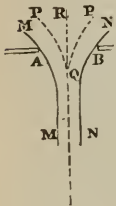

Fig. 136

This part of the jet is called the *vena contracta*. It is found that the area of its smallest section is about $\frac{5}{8}$ or 0.625 of that of the orifice. Accordingly, the true value of the efflux per second is given approximately by the formula

$$E = 0.62A\sqrt{2gh},$$

or the actual value of E is about 0.62 of its *theoretical value*.

146. **Influence of tubes on the quantity of efflux.**—The result given in the last article has reference to an aperture in a thin wall. If a cylindrical or conical efflux tube is fitted to the aperture, the amount of the efflux is considerably increased, and in some cases falls but little short of its theoretical value.

A short cylindrical ajutage, whose length is from two to three times its diameter, has been found to increase the efflux per second to about $0.82A\sqrt{2gh}$. In this case the water on entering the ajutage forms a contracted vein (fig. 137), just as it would do on issuing freely into the air; but afterwards it expands, and, in consequence of the adhesion of the water to the interior surface of the tube, has, on leaving the ajutage, a section greater than that of the contracted vein. The contraction of the jet within the ajutage causes a partial vacuum. If an aperture is made in the ajutage, near the point of greatest contraction, and is fitted with a vertical tube, the other end of which dips into water (fig. 137), it is found that water rises in the vertical tube, thereby proving the formation of a partial vacuum.

If the ajutage has the form of a conical frustum whose larger end is at the aperture, the efflux-rate may be raised to $0.92A\sqrt{2gh}$, provided the dimensions are properly chosen. If the smaller end of a frustum of a cone of suitable dimensions be fitted to the orifice, the efflux may be still further increased, and fall very little short of the theoretical amount.

When the ajutage has more than a certain length, a considerable diminution takes place in the amount of the efflux; for example, if its length is 48 times its diameter, the efflux is reduced to $0.63A\sqrt{2gh}$. This arises from the fact that, when water passes along cylindrical tubes, the resistance increases with the length of the tube; for a thin layer of liquid is attracted to the walls by adhesion, and the internal flowing liquid rubs against this. The resistance which gives rise to this result is called *hydraulic friction*; it is independent of the material of the tube, provided the tube is not roughened; but depends chiefly on the viscosity of the liquid; for instance, ice-cold water experiences a greater resistance than lukewarm water.

According to Prony, the mean velocity v of water in a cast-iron pipe of the length l , and the diameter d , under the pressure p , is in metres

$$v = 26.8 \sqrt{\frac{pd}{l}}$$

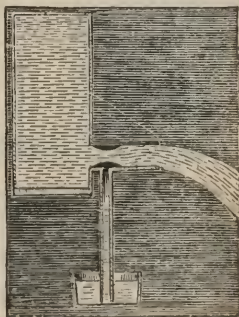

Fig. 137

This is on the assumption that the tubes are straight. Any angle or curvature of the tube diminishes the velocity, seeing that part of the motion

is used up in pressure against the sides. Thus Venturi found that the time requisite to fill a small vessel by means of a tube 38 inches in length by 3·3 in diameter was 45, 50, or 70 seconds, according as the tube was straight, curved, or bent at a right angle.

By means of hydraulic pressure Tresca submitted solids such as silver, lead, iron and steel, powders like sand, soft plastic substances such as clay, and brittle bodies like ice, to such enormous pressures as 100,000 kilogrammes per square centimetre, and found that they then behave like fluid bodies. His experiments show also that these bodies transmit pressure equally in all directions when the pressure is large enough.

147. **Viscosity. Efflux through capillary tubes.**—The flow of liquids through fine tubes was investigated by Poiseuille (in 1843) by means of the apparatus represented in fig. 138, in which the capillary tube AB

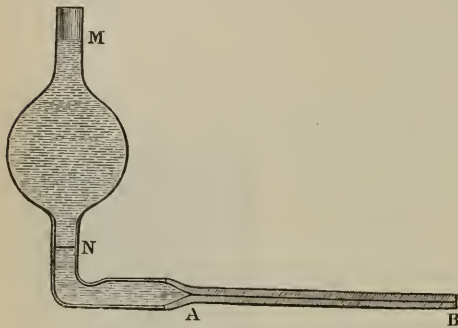

Fig. 138

is sealed to a glass tube on which a bulb is blown. The volume of the space between the marks M and N is accurately determined, and the apparatus, having been filled with the liquid under examination by suction, is connected at the end M with a reservoir of compressed air, in which the pressure is measured by means of a mercury manometer (184). The time is then noted which is required for the level of the liquid to

sink from M to N, the pressure remaining constant. It is thus found that V , the volume which flows out in a second, is, with close approximation, represented by the formula

$$V = \frac{\pi p r^4}{8 \eta l},$$

where l is the length and r the diameter of the tube in centimetres, p the pressure in dynes per square centimetre, and η the *coefficient of internal friction*, or *coefficient of viscosity*; which may be defined as the resistance to motion offered by two layers of the liquid of unit surface, and at unit distance apart, one layer being supposed fixed and the other moving over and parallel to it. If R is the resistance per unit area experienced by the layer moving with velocity v , and a be the distance between the fixed and moving layers, $R = \frac{v}{a} \eta$. When we know the dimensions of the apparatus, a

determination of the volume which flows out in a given time is a ready means of obtaining η . If the liquid which flows out through the tube is one which moistens it, a layer of liquid adheres to the side; and accordingly the friction which the liquid experiences is not that against the sides, but that of the particles against each other. This coefficient varies with the nature of the

liquid and the temperature. The liquids ether, water, sulphuric acid, linseed oil, Venice turpentine, syrup, pitch, represent, for instance, a series with increasing viscosity. The reciprocal of the viscosity, or $\frac{1}{\eta}$, is called the *fluidity*; it appears probable that this increases with the temperature in the same ratio as the conductivity for electricity. The coefficient of internal friction is greater in the case of solution of salts than with water, and increases with the strength of the solution. It greatly diminishes with the temperature, and, for water, at 60° is one-third what it is at zero.

A convenient apparatus for the purpose, more particularly for comparative measurements, is that given by Ostwald (fig. 139). It consists essentially of a tube, *dc*, which is narrowed at *c*, and opens into a bulb, to which is attached the capillary *ab*, which again terminates in the wider tube *be*. The tube is filled with liquid from the bottle up to the point *c*, by aspiration through the rubber tube; the liquid is then allowed to flow out, and the time noted which its surface takes in falling from *c* to a mark, *a*. If the experiment is made with water, which is taken as standard, then, using the same apparatus, other liquids may be compared with it; this has the advantage of dispensing with a determination of the dimensions of the tube, and particularly of the diameter—a matter of importance, since its fourth power occurs in the formula, and thus any error in its determination greatly affects the result.

If *t* is the time required for the flow of the given volume of water, and *t'* that of a liquid whose coefficient is η' and sp. gr. σ , then

$$\frac{\eta'}{\eta} = \frac{\sigma t'}{t},$$

the coefficient of viscosity of water being η , and its density unity.

A lubricating substance applied between an axle and its bearing adheres on the one hand to the axle, and on the other to the bearing: the outer layer is at rest, the inner one rotates with the axle. The internal friction acts in opposition to the motion, and the advantage of lubricators is that this internal friction is far less than the sliding friction.

By observing the rate of diminution in the amplitude of the oscillations of a horizontal disc suspended by a thread when immersed in water, Meyer determined the coefficient of viscosity of water, and found that at 10° it was equal to 0.01567, at 20° it is .01; for air, which is 770 times as light as water, the viscosity is .00018 at 20° , or only about $\frac{1}{50}$ that of water.

148. **Surface viscosity.**—The *surface viscosity* of a liquid is sometimes much greater than its internal viscosity. The difference between the two is exhibited in a marked manner by a solution of saponine in water. Let a small compass needle be pivoted on a point and placed inside a glass vessel, and saponine solution be poured into the vessel so as entirely to cover the

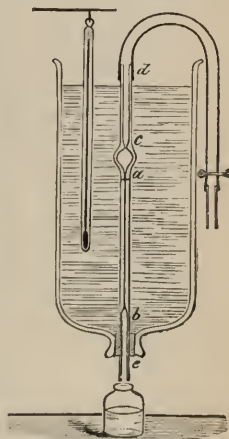

Fig. 139

needle. The needle will be deflected by the approach of a magnet on the outside, and will, when the magnet is removed, oscillate once or twice before coming to rest. But if the needle is *on the surface* of the liquid the resistance to motion is enormously greater, and a strong magnet must be brought quite close to the needle before it will produce any deviation. In the case of water and most other liquids no such marked difference is found between the surface and internal friction.

149. **Form of the jet.**—When water issues by a circular aperture in the bottom or side of a vessel, after the contracted vein, the jet has the form of a solid rod for a short distance, but then begins to separate into drops, which present a peculiar appearance. They seem to form a series of ventral and nodal segments (fig. 140). The ventral segments consist of drops extended



Fig. 140

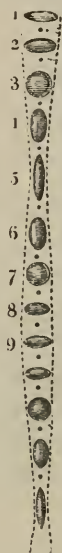

Fig. 141

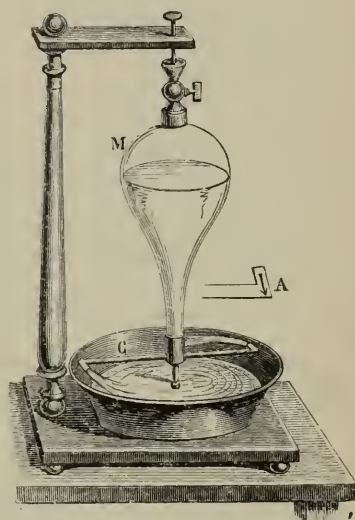

Fig. 142

in a horizontal direction, and the nodal segments in a longitudinal direction. And as the ventral and nodal segments have respectively a fixed position, each drop must alternately become elongated and flattened while it is falling (fig. 141). Between any two drops there are smaller ones, so that the whole jet has a tube-like appearance.

These alterations in form have been explained as being due to vibrations in the mouth of the vessel itself. Their position is modified by extraneous influences, such as musical and other sounds, but only when these influences affect the edges themselves. When the vibrations of the vessel itself are stopped, the enlargements and contractions in the jet cease also; they are strengthened, on the contrary, if a violoncello, for instance, is sounded.

If the jet is illuminated momentarily by the electric spark, its structure is well seen; the drops appear then to be stationary and separate from each

other. If the aperture is not circular, the form of the jet undergoes curious changes.

When air issues from a gasholder under a pressure of 48 atmospheres, the jet can be ascertained by photography to be resolved into a series of drops of air following each other at equal intervals.

150. **Barker's mill.**—If water is contained in a vessel, and an aperture is made in one of the sides, the pressure at this point is removed, for it is expended in sending out the water; but it remains on the other side; and if the vessel were movable in a horizontal direction, it would move in a direction opposite to that of the issuing jet. This is illustrated by the apparatus known as the *hydraulic tourniquet* or *Barker's mill* (fig. 142). It consists of a glass vessel, M, containing water, and capable of moving about its vertical axis. At the lower part there is a tube, C, bent horizontally in opposite directions at the two ends. If the vessel were full of water and the tubes closed, the pressure on the opposite ends of the part A would balance each other, being equal and acting in contrary directions; but, when the cap is removed from the end of A, the water runs out, and the pressure is not exerted on the open part, but only on the opposite side, as shown by the arrow. And this pressure, not being neutralised by an opposite pressure, imparts a rotatory motion in the direction of the arrow, the velocity of which increases with the height of the liquid and the size of the aperture.

The same principle may be illustrated by the following experiment. A tall cylinder containing water, and provided with a lateral stopcock near the bottom, is placed on a light shallow dish on water, so that it easily floats. On opening the stopcock so as to allow water to flow out, the vessel is observed to move in a direction diametrically opposite to that in which the water is issuing. Similarly, if a vessel containing water is suspended by a string, and an aperture is made in one of the sides, the water will jet out, and the vessel be deflected away from the vertical in the opposite direction.

Segner's water-wheel and the reaction machine depend on this principle. So also do rotating fireworks; that is, an unbalanced reaction from the heated gases which issue from openings in them gives them motion in the opposite direction.

151. **Water-wheels. Turbines.**—When water is continuously flowing from a higher to a lower level, it may be made use of as a motive power either in virtue of its potential energy, or by allowing it to descend and making use of the resulting kinetic energy. The motive power of water is utilised in practice either by the agency of *water-wheels, turbines, rams, or hydraulic engines.*

Water-wheels are wheels provided with buckets or float-boards at the circumference, on which the water acts either by pressure or by impact. They are made to turn about a horizontal axis, and are of two principal kinds, *undershot* and *overshot*. In *undershot* wheels the float-boards are placed radially—that is, at right angles to the circumference of the wheel. The lowest float-boards are immersed in the water, which flows with a velocity depending on the height of the fall and the narrowing of the channel at the wheel. Such wheels are applicable where the quantity of water is great but the fall inconsiderable, the kinetic energy of the water being directly converted into mechanical work. *Overshot* wheels are

used with a small quantity of water which has a high fall, as with small mountain streams. On the circumference of the wheel there are buckets of a peculiar shape. The water falls into the buckets on the upper part of the wheel, which is thus moved by the weight of the water, and as each bucket arrives at the lowest point of revolution it discharges all the water, and ascends empty.

An overshot wheel driven by an extraneous force may be used for raising water, as in dredging machines ; and an undershot wheel for moving a vessel to which its axis is fixed, as in the paddles of steam-vessels.

The *turbine* is similar in principle to the hydraulic tourniquet or reaction wheel (150). Turbines may be divided into two general classes, viz. Reaction and Impulse turbines. In the former the energy of the water is partly due to the pressure head of the supply and is in part kinetic. As the water passes through the machine the pressure is gradually reduced to that at the exit, viz. atmospheric, thus reacting on the blades of the wheel and producing rotation. A turbine consists of a pair of discs, one above the other, connected together by a number of specially shaped thin blades, which divide the space between the discs into an equal number of curved radial chambers. The wheel works generally upon a vertical axis. There are three types of Reaction turbines, *outward flow*, *inward flow*, and *parallel*, the names referring to the direction in which the water flows relative to the axis. In an *outward flow turbine*, the water enters at the centre of the wheel, passing through the space between the discs, and outwards radially. In order to prevent waste of energy in giving useless rotation to the water, the openings at which the water enters the wheel are surrounded by a series of corresponding fixed chambers, whose sides (*guide-blades*) are so curved that the water when it leaves them flows on to the wheel-blades, which are also curved, in such a manner that the velocity of the water relatively to the wheel is along the blade, thus enabling the wheel to take the water without shock ; similarly the curve of the blades at exit enables the water to be discharged with a velocity relative to the wheel, equal and opposite to that of its circumference, so that the escaping water has only a small velocity in space in a direction along the radius just sufficient to clear the wheel.

In *inward flow turbines* the water enters, between guide-plates, at the outer circumference, and passing through the wheel is discharged at the centre or 'eye.'

In *parallel flow turbines* both the guide and wheel passages are arranged parallel to the axis, so that the motion of the water is roughly parallel to the axis. The largest turbine in existence has recently been erected at the Shawinigan Falls, 90 miles from Montreal ; in this turbine the central opening for the inflowing water is 10 feet in diameter.

In *Impulse turbines* all the pressure head is converted into kinetic energy before reaching the machine, and the action of the wheel is to convert the kinetic energy directly into mechanical work. The best of the type is the *Pelton wheel* ; in this the wheel, which is enclosed in a case, has a number of hemispherical cups arranged around its periphery with their diametral planes parallel to the axis, and one or more nozzles project into the case and discharge jets of water at a high velocity into the cups ; the curve of the cups

combined with the speed of the wheel ensures the water falling clear of the wheel to the lower part of the case, where it is drained away. If the speed of the buckets were half the speed of the jet the whole of the velocity of the water would be absorbed, the water simply falling from the buckets by gravity, and then the efficiency would be 100 per cent. But in practice the water must have a small velocity to ensure it clearing the wheel, and, besides, a bucket passing into the jet interferes slightly with the one passing out, and an efficiency of only about 80 per cent. can be obtained.

It might be mentioned that in a reaction type of turbine if the supply of water is small, so that the passages are not filled, and consequently the pressure is atmospheric throughout the wheel, the action is purely that of an impulse turbine.

The total theoretical effect of a fall of water is never realised ; for the water, after acting on the wheel, still retains some velocity, and therefore does not impart the whole of its energy to the wheel. In many cases water flows past without acting at all ; if the water acts by impact, vibrations are produced which are transmitted to the earth and lost ; the same effect is produced by the friction of water over an edge of the sluice, in the channel which conveys it, or against the wheel itself, as well as by the friction of this latter against the axle. A wheel working freely in a stream, as with the corn mills on the Rhine near Mainz, does not utilise more than 50 per cent. of the theoretical effect. One of the most perfect forms of turbine will work up to over 80 per cent. Turbines also, when properly designed, may be made to have a very high efficiency either with high or low falls ; while, on account of the great speed at which they run, they are very much smaller than water-wheels in proportion to their power. They are thus more 'efficient' motors than steam-engines, which, even if perfect, can only transform into work from 25 to 30 per cent. of the energy represented by the coal they burn, and seldom in practice utilise more than half of this percentage.

151A. **Centrifugal pumps.**—The reaction turbines are reversible, and may be converted into pumps by being driven in the opposite direction and having the direction of the water reversed. The general type is obtained by reversing an inward flow turbine, the wheel, or 'impeller,' being rotated by a steam-engine or other prime mover, and water is supplied at the centre with radial velocity only. The blades are curved in such a way that a gradual rotational velocity is imparted to the water as it passes through the wheel ; this additional kinetic energy causes the water to escape at the outer circumference into a circular chamber, arranged with a gradually increasing area of section as it completes the circumference of the wheel ; by means of this chamber the velocity of the water is gradually diminished, producing an increase in pressure which enables the water to be discharged at a considerable height, or, as in the case of a surface condenser of the marine type, through a number of small diameter tubes involving large frictional resistances.

152. **The hydraulic ram.**—If a quantity of water flows through a pipe open at the lower end, and if this aperture is quickly closed, a sudden impact will be exerted on the closure as well as on the sides of the pipe. Some of the energy of the falling water is thereby converted into heat, and some exerts a dangerous pressure on the pipe. The existence of this pressure may be readily

observed in any town with a high-pressure water supply, by the sharp click heard if the tap through which water is flowing is suddenly closed.

The *hydraulic ram* invented by Montgolfier is an arrangement by which the energy of falling water is applied so as to raise a portion of it to a greater height than the reservoir from which it is fed.

The principle of such an arrangement is represented in fig. 143, in which E is the reservoir, A the pipe in which the water falls, B the channel, which should be long and straight, *a* and *b* the valves, *a* opening downwards and *b* upwards, C the air-chest, and D the rising main. Water first flows out in quantity through the valve *a*, and as soon as it has acquired a certain velocity it raises that valve, and the aperture is shut. The impact thus produced, acting on the sides of the pipe and on the valve *b*, raises this valve, and a quantity of water passes into the reservoir C, compressing the air in the space above the mouth *d* of the rising main D. This air by its elastic force closes the valve *b*, and the water which has entered is raised in the main pipe D.

As soon as the impulsive action is over, and the water in the channel is at rest, the valve *a* falls again by its own weight, the flow begins afresh,

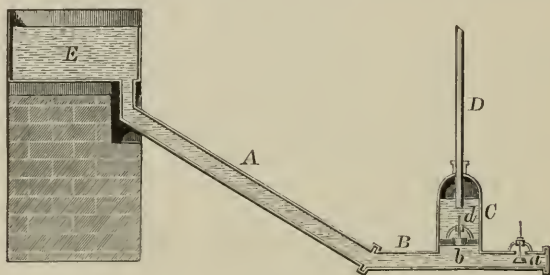

Fig. 143

and when it has acquired sufficient velocity the valve *b* is again closed, and the whole process is repeated.

In this way water can be raised to a height many times as great as the difference in level from E to the valve *b*. If no energy were lost in friction, and in raising the valves, the height of ascent would be to the fall as the quantity of water which flows out at *a* is to that which is raised. Thus $\frac{1}{3}$ of the water flowing out of the channel could be raised to four times the height of the available fall.

153. Hydraulic engine.—Historically, falling water was one of the earliest sources of power; but it is only in recent times that attention has been called (first by Lord Armstrong) to the advantage of using hydraulic power in towns and other places where there is no *natural* fall of water for driving certain classes of machines, in those cases more especially where the use of the machinery is only intermittent.

For this purpose the most important docks and large warehouses are now generally furnished with means of obtaining a water supply at a very high pressure, generally about 700 pounds to the square inch. Steam-pumping engines are employed to pump water more or less continuously

into what are practically large cylinders with immensely heavy pistons loaded to the required pressure. These vessels are called *accumulators*, and pipes from them are led away to the various places (lock gates, sluice valves, cranes, capstans, &c.) where power may be wanted. At each of these places there is some kind of hydraulic motor suitable to the particular work to be done, and this motor can be instantaneously set to work by opening the communication between it and the high-pressure water in the accumulator. The motor used is not uncommonly a small engine similar in principle to a steam-engine, and one of the best of these engines is that illustrated in fig. 144, which is the invention of Schmidt of Zürich. It consists of a cylinder fitted with a piston, *c*, whose rod is connected directly to a crank upon a horizontal shaft. The cylinder has two *ports* or passages, *a* and *b*, one at each end, both terminating below in openings upon a convex curved face, which is kept continually pressed against a similar concave face upon

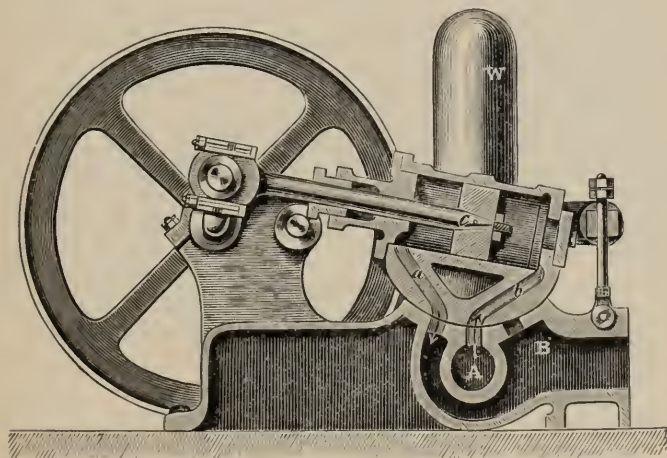

Fig. 144

the framing of the engine. In this fixed face are also an inlet port or passage A, and outlet passages B. When the cylinder is in the position shown in the figure, the high-pressure water is passing through A and *b*, forcing the piston along, and driving out the already used water through *a* and B. As the piston moves and turns the crank, the cylinder oscillates on its bearings, and by the time the piston has got to the end of its stroke, the cylinder then being horizontal, the process is just being reversed, water passing in through A and *a*, and out through *b* and B. W is an air-vessel for preventing shocks.

This motor utilises 90 per cent. of the available power; in this respect it far exceeds a steam-engine, which does not utilise more than 10 per cent. of the power due to the consumption of the coal burnt.

The chief drawback to the use of water-power, except where there is a large natural supply under pressure, is its expense. For each revolution

of the crank shaft two complete cylinders full of water must be passed through such an engine, as the water cannot be expanded like steam.

With any given pressure it is easy to find out how much water will be required for a given power. At a pressure of 30 pounds per square inch, for instance, one horse-power will require, supposing the *efficiency* of the machine to be 70 per cent. (480), $\frac{33,000 \times 60}{30 \times 144 \times 0.7}$ = about 655 cubic feet or 4000

gallons per hour, a quantity the cost of which would in most cases put the use of this power out of the question. The pressure in town mains generally lies between 20 and 40 pounds per square inch, and it is therefore only in cases where a special high-pressure supply is available that the power can be economically used.

In London, water is supplied to consumers by the Hydraulic Power Company under a pressure of 700 pounds; and the quantity required for one horse-power would be about 175 gallons. The cost of power supplied in this way is about fourpence per horse-power per hour, which, although expensive for continuous working, is not so when it is intermittently used, and when only the quantity actually consumed is paid for.

Water-power is usually represented by the weight of the water multiplied into the height of the available fall; or it may also be represented by half the product of the mass into the square of the velocity. Both measurements give the same result (61). The mass of water falling every hour over Niagara is estimated at 100,000,000 tons; taking the vertical depth at 150, and adding to this 150 as representing the velocity, we have a total fall from lake to lake of 300 feet. The chief fall alone would furnish 16,800,000 horse-power, which, if furnished by steam, would require an annual consumption of 260,000,000 tons of coal, taking 4 pounds per hour for the horse-power. This is more than all the coal raised in the year in the whole world.

BOOK IV

ON GASES

CHAPTER I

PROPERTIES OF GASES. ATMOSPHERE. BAROMETERS

154. **Physical properties of gases.**—Gases are bodies which, unlike solids, have no independent shape, and, unlike liquids, have no independent volume. Their molecules possess almost perfect mobility; they are conceived as darting about in all directions, and are continually tending to occupy a greater space. From their expansibility and compressibility gases are often called *elastic fluids*.

Gases and liquids have several properties in common, and some in which they seem to differ are in reality only different degrees of the same property. Thus, in both, the particles are capable of moving; in gases with almost perfect freedom; in liquids not quite so freely, owing to a greater degree of viscosity (147). Both are compressible, though in very different degrees. If a liquid and a gas both exist under the pressure of one atmosphere, and then the pressure is doubled, the water is compressed by about the $\frac{1}{20000}$ part, while the gas is compressed by one-half. In density there is a great difference: water, which is the type of liquids, is about 770 times as heavy as air, the type of gaseous bodies, while under the pressure of one atmosphere. A gas has no original volume; it is always elastic, or, in other words, it is always striving to attain a greater volume; this tendency to indefinite expansion is the chief property by which gases are distinguished from liquids. A spiral spring only shows elasticity when it is compressed or extended; it loses its tension when it has returned to its primitive condition.

By the aid of pressure and of low temperatures, the force of cohesion may be so far increased in many gases that they are readily converted into liquids, and with sufficient pressure and cold all gases may be liquefied. On the other hand, heat, which increases the kinetic energy of the molecules, converts liquids, such as water, alcohol, and ether, into the aeriform state in which they obey all the laws of gases. An aeriform substance is called a vapour or a gas according as it can or cannot without change of temperature be compressed into a liquid; that is, it is a gas if its temperature is above its critical temperature (373) and a vapour if below.

Formerly, it was usual to describe as a vapour a substance which at ordinary temperatures is liquid (for instance, steam), and as a gas a substance which, at ordinary temperatures and pressures, exists in the gaseous state.

In describing the properties of gases we shall, for obvious reasons, refer to atmospheric air as their type.

155. **Expansibility of gases.**—This property of gases, their tendency to assume continually a greater volume, is exhibited by means of the following experiment :—A bladder, closed by a stop-cock and about half full of air, is placed under the receiver of the air-pump (fig. 145). When the pump is worked the bladder immediately distends. This arises from the fact that the molecules of air flying about in all directions (294) press against the sides of the bladder. Under ordinary conditions, the pressure inside the bladder is counterbalanced by the air in the receiver, which exerts an equal and contrary pressure. But when the pressure inside the bladder is removed or partially removed, by exhausting the receiver, the internal pressure becomes evident. When air is admitted into the receiver, the bladder resumes its original form.

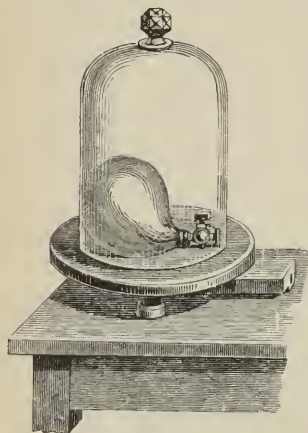

Fig. 145

156. **Compressibility of gases.**—The compressibility of gases is readily shown by the *pneumatic syringe* (fig. 146). This

consists of a stout glass tube closed at one end, and provided with a tight-fitting solid piston. When the rod of the piston is pressed it moves down in the tube, and the air becomes compressed into a smaller volume ; but as soon as the force is removed the air regains its original volume, and the piston rises to its former position.

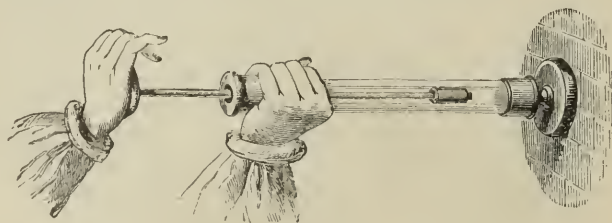

Fig. 146

157. **Weight of gases.**—From their extreme fluidity and expansibility, gases seem to be uninfluenced by the force of gravity : they nevertheless possess weight like solids and liquids. To show this, a glass globe of 3 or 4 quarts capacity is taken (fig. 147), the neck of which is provided with a stop-cock, which hermetically closes it, and by which it can be screwed to the plate of the air-pump. The globe is then exhausted, and its weight determined by means of a delicate balance. Air is now allowed to enter, and the

globe again weighed. The weight in the second case will be found to be greater than before, and if the capacity of the vessel is known in cubic centimetres, the increase will obviously be the weight of that volume of air, and from it the weight per cubic centimetre or per litre can be determined.

By a modification of this method, and with the adoption of certain precautions, the weight of air and of other gases has been determined. Perhaps the most accurate are those of Regnault, who found that a litre of dry air at 0° C., and under a pressure of 760 millimetres, weighs 1.293187 gramme. Since a litre of water (or 1000 cubic centimetres) at 0° weighs .999877 gramme, the density of air is 0.00129334 that of water under the same conditions; that is, water is 773 times as heavy as air at 0° C. Expressed in English measures, 100 cubic inches of dry air under the ordinary atmospheric pressure of 30 inches and at the temperature of 16° C. weigh 31 grains; the same volume of carbonic acid gas under the same circumstances weighs 47.25 grains; 100 cubic inches of hydrogen, the lightest of all gases, weigh 2.14 grains; and 100 cubic inches of hydriodic acid gas weigh 146 grains.



Fig. 147

158. **Pressure exerted by gases.**—Gases exert on their own molecules, and on the sides of vessels which contain them, pressures which may be regarded from two points of view. First, we may neglect the weight of the gas; secondly, we may take account of its weight. If we neglect the weight of any gaseous mass at rest, and only consider its expansive force, it will be seen that the pressures due to this force act with the same strength on all points, both of the mass itself and of the vessel in which it is contained. This principle of the equality of the pressure of gases in all directions may be shown experimentally by means of an apparatus resembling that by which the same principle is demonstrated for liquids (fig. 76).

If we consider the weight of any gas, we shall see that it gives rise to pressures which obey the same laws as those produced by the weight of liquids. Let us imagine a cylinder, with its axis vertical, several miles high, closed at both ends and full of air. Let us consider any small portion of the air enclosed between two horizontal planes. This portion must sustain the weight of all the air above it, and transmit that weight to the air beneath it, and likewise to the curved surface of the cylinder which contains it, and at each point in a direction at right angles to the surface. Thus the pressure increases from the top of the column to the base; at any given layer it acts equally on equal surfaces, and at right angles to them, whether they are horizontal, vertical, or inclined. The pressure acts on the sides of the vessel, and on any small surface it is equal to the weight of a column of gas whose base is this surface, and whose height is its distance from the summit of the column. The pressure is also independent of the shape and dimensions of the supposed cylinder, provided the height remains the same.

For a small quantity of gas the pressures due to its weight are quite insignificant, and may be neglected; but for large quantities, like the atmosphere, the pressures are considerable, and must be allowed for.

159. **The atmosphere: its composition.**—The atmosphere is the layer of air which surrounds our globe in every part. It partakes of the rotatory motion of the globe, and would remain fixed relatively to terrestrial objects but for local circumstances, which produce winds, and are constantly disturbing its equilibrium.

It is essentially a mixture of oxygen and nitrogen gases, its average composition by volume being as follows:—

Nitrogen	78.49
Oxygen	20.63
Aqueous vapour	0.84
Carbonic acid	0.04
	100.00

The nitrogen of the atmosphere has recently (in 1894) been found by Lord Rayleigh and Sir William Ramsay to contain about 1 per cent. of a new gaseous element to which, in consequence of its extraordinary inertness, its discoverers have given the name *argon*. Argon is about half as dense again as ordinary nitrogen, and is condensed at a temperature of $-121^{\circ}\text{C}.$, under a pressure of 51 atmospheres, to a colourless liquid. When cooled to $-190^{\circ}\text{C}.$ it solidifies. More recently Ramsay has discovered the presence of other gases in the atmosphere along with argon, to which the names *neon*, *krypton*, and *xenon* have been given. It is probable also that hydrogen exists in the atmosphere in small quantities.

The carbonic acid arises from the respiration of animals, from the process of combustion, and from the decomposition of organic substances. Boussingault estimated that in Paris the following quantities of carbonic acid are produced every 24 hours:—

By the population and by animals	11,895,000 cubic feet
By processes of combustion	92,101,000 „
	103,996,000 „

Notwithstanding this enormous continual production of carbonic acid the composition of the atmosphere does not sensibly vary; for plants in the process of vegetation decompose the carbonic acid, assimilating the carbon, and restoring to the atmosphere the oxygen, which is being continually consumed in the processes of respiration and combustion.

160. **Atmospheric pressure.**—If we neglect the perturbations to which the atmosphere is subject, as being inconsiderable, we may consider it as a fluid sea of a certain depth, surrounding the earth on all sides, and exercising the same pressure as if it were a liquid of very small density. Consequently, the pressure on the unit of area is constant at a given level, being equal to the weight of the column of atmosphere above that level whose horizontal section is the unit of area (98). It will act at right angles to the surface, whatever be its position. It will diminish as we ascend, and increase as we descend from that level. Thus, at the same height, the atmospheric pressures on unequal plane surfaces will be proportional to the areas of those surfaces, provided they are small in proportion to the height of the atmosphere.

In virtue of the expansive force of the air, it might be supposed that the molecules would expand indefinitely into the planetary spaces. But, in

proportion as the air expands, its expansive force decreases, it is further weakened by the low temperature of the upper regions of the atmosphere, so that, at a certain height, equilibrium is established between the expansive force which separates the molecules and the action of gravity which draws them towards the centre of the earth. It is therefore concluded that the atmosphere is limited.

From the rate at which the density of the atmosphere diminishes as we ascend, and from the observation of certain phenomena of twilight, its height has been estimated at from 30 to 40 miles. Above that height the air is extremely rarefied, and at a height of 60 miles it is assumed that there is a perfect vacuum. On the other hand, meteorites have been seen at a height of 200 miles, and, as their luminosity is undoubtedly due to friction against air, there must be air at such a height. This higher estimate is supported by observations made at Rio Janeiro on the twilight arc, by M. Liais, who estimated the height of the atmosphere at between 198 and 212 miles. The question as to the exact height of the atmosphere must therefore be considered as still awaiting settlement.

As it has been previously stated that 100 cubic inches of air weigh 31 grains, it will readily be conceived that the whole atmosphere exercises a considerable pressure on the surface of the earth. The existence of this pressure is shown by the following experiments.

161. **Crushing force of the atmosphere.**—On one end of a stout glass cylinder, about 5 inches high, and open at both ends, a piece of bladder is tied quite air-tight. The other end, the edge of which is ground and well

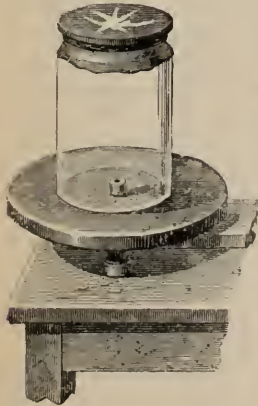

Fig. 148



Fig. 149



Fig. 150

greased, is pressed on the plate of the air-pump (fig. 148). As soon as the air in the vessel is rarefied by working the air-pump, the bladder is depressed by the weight of the atmosphere above it, and finally bursts with a loud report caused by the sudden entrance of the air.

162. **Magdeburg hemispheres.**—The preceding experiment only serves to illustrate the downward pressure of the atmosphere. By means of the *Magdeburg hemispheres* (figs. 149 and 150), the invention of which is due to Otto von Guericke, burgomaster of Magdeburg, it can be shown that the pressure acts in all directions. This apparatus consists of two hollow brass hemispheres of 4 to 4½ inches diameter, the edges of which are made to fit tightly, and are well greased. One of the hemispheres is provided with a stopcock, by which it can be screwed on to the air-pump, and on the other there is a handle. As long as the hemispheres contain air they can be separated without any difficulty, for the external pressure of the atmosphere is counter-balanced by the pressure of the air in the interior. But when the air in the interior is pumped out by means of the air-pump, the hemispheres cannot be separated without a powerful effort: and as this is the case in whatever position they are held, it follows that the atmospheric pressure is exerted in all directions.

DETERMINATION OF ATMOSPHERIC PRESSURE. BAROMETERS

163. **Torricelli's experiment.**—The above experiments demonstrate the existence of the atmospheric pressure, but they give no precise indication as to its amount. The following experiment, which was first made in 1643 by Torricelli, a pupil of Galileo, gives an exact measure of the pressure of the atmosphere.

A glass tube is taken, about a yard long and a quarter of an inch internal diameter (fig. 151). It is sealed at one end, and is quite filled with mercury. The aperture C being closed by the thumb, the tube is inverted, the open end placed in a small mercury trough, and the thumb removed. The tube being in a vertical position, the column of mercury sinks, and, after oscillating some time, it finally comes to rest at a height, A, about 30 inches above the mercury in the trough. The mercury is raised in the tube by the pressure of the atmosphere on the mercury in the trough. There is no contrary pressure on the mercury in the tube, because it is closed; but, if the end of the tube is opened, the atmosphere will press equally inside and outside the tube, and the mercury will sink to the level of that in the trough. It has been shown in Hydrostatics (106) that the heights of two columns of liquid in communi-

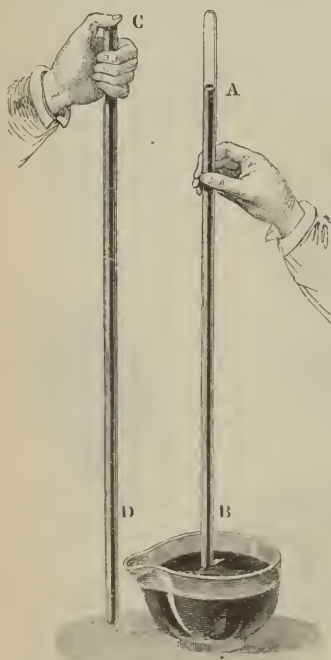

Fig. 151

cation with each other are inversely as their densities; and hence it follows that the pressure of the atmosphere is equal to that of a column of

mercury the height of which is 30 inches. If the pressure of the atmosphere diminishes, the height of the column which it can sustain must also diminish.

164. **Pascal's experiments.**—Pascal, who wished to ascertain whether the force which sustained the mercury in the tube was really the pressure of the atmosphere, made the following experiments. (i.) If it were the case, then the column of mercury ought to be lower in proportion as we ascend in the atmosphere. He accordingly requested one of his relatives to repeat Torricelli's experiment on the summit of Puy de Dôme in Auvergne. This was done, and it was found that the column of mercury was about 3 inches lower, thus proving that it is really the pressure due to the weight of the atmosphere which supports the mercury, since, when this weight diminishes, the height of the column also diminishes. (ii.) Pascal repeated Torricelli's experiment at Rouen in 1646, with other liquids. He closed a tube nearly 50 feet long, at one end, and, having filled it with water, placed it vertically in a vessel of water, and found that the water stood in the tube at a height of 34 feet; that is, 13·6 times as high as mercury. But since the mercury is 13·6 times as heavy as water, the height of the column of water was exactly equal to that of a column of mercury in Torricelli's experiment, and it was consequently the same cause, the pressure of the atmosphere, which successively supported the two liquids. Pascal's other experiments with oil and with wine gave similar results.

165. **Amount of the atmospheric pressure.**—Let us assume that the tube in the above experiment is a cylinder, the section of which is equal to a square inch; then, since the height of the column of mercury, in round numbers, is 30 inches, the column will contain 30 cubic inches; and as a cubic inch of mercury weighs 3433·5 grains = 0·49 of a pound, the pressure of such a column on a square inch of surface is equal to 14·7 pounds. In round numbers, the pressure of the atmosphere is taken at 15 pounds on the square inch. A surface of a foot square contains 144 square inches, and therefore the pressure upon it is equal to 2117 pounds, or nearly a ton. Expressed in the metric system the standard atmospheric pressure at 0° and the sea-level is 760 millimetres, which is equal to 29·9217 inches; and a calculation similar to the above shows that the pressure on a square centimetre is = 1·032896 kilogramme, or $1·01327 \times 10^6$ dynes per square centimetre.

For convenience of calculation Everett has proposed to adopt the pressure of a megadyne per square centimetre, or 10^6 C.G.S. units of pressure-intensity, as the standard pressure; this with a value of $g=981·17$ at Greenwich for this country would represent a height of 74·96 cm. or 29·513 inches.

A pressure of 15 pounds per square inch is called a pressure of *one atmosphere*. If, for instance, the pressure of the steam in a boiler is such that each square inch of the internal surface is exposed to a pressure of 90 pounds (= 6×15), we say that the steam is under a pressure of six atmospheres.

The surface of the body of a man of middle size is about 16 square feet; the pressure, therefore, which a man supports on the surface of his body is 35,560 pounds, or nearly 16 tons. Such an enormous pressure might seem impossible to be borne; but it must be remembered that, in all directions, there are equal and contrary pressures which counterbalance one another.

It might also be supposed that the effect of this pressure, acting in all directions, would be to press the body together and crush it. But the solid parts of the skeleton could resist a far greater pressure; and as to the air and liquids contained in the organs and vessels, the air has the same density as the external air, and cannot be further compressed by the atmospheric pressure; and from what has been said about liquids (96), it is clear that they are virtually incompressible. Only by considerable variations in pressure is the body affected, as by ascending great heights, or by divers in diving bells and the like. When the external pressure is removed from any portion of the body, either by means of a *cupping-vessel* or by the air-pump, the pressure from within is seen by the distension of the surface.

166. **Different kinds of barometers.**—The instruments used for measuring the atmospheric pressure are called *barometers*. In ordinary barometers the pressure is measured by the height of a column of mercury, as in Torricelli's experiment; the barometers which we are about to describe are of this kind. But there are barometers without any liquid, one of which, the aneroid (188), is remarkable for its simplicity and portability.

167. **Cistern barometer.**—The *cistern barometer* consists of a straight glass tube closed at one end, about 33 inches long, filled with mercury and dipping into a cistern also containing mercury. In order to render the barometer more portable, and the variations of level in the cistern less perceptible when the mercury rises or falls in the tube, several different forms have been constructed. Fig. 152 represents one form of the cistern barometer. The apparatus is fixed to a vertical support, on the upper part of which there is a scale graduated in millimetres or inches from the level of the mercury in the cistern; a movable index, *o*, shows on the scale the level of the mercury. A thermometer on one side indicates the temperature.

There is one fault to which this barometer is liable, in common with all others of the same kind. The zero of the scale does not always correspond to the level of the mercury in the cistern. For, as the atmospheric pressure is not always the same, the height of the mercurial column varies; sometimes mercury is forced from the cistern into the tube, and sometimes from the tube into the cistern, so that in the majority of cases the graduation of the barometer does not indicate the true height. If the diameter of the cistern is large, relatively to that of the tube, the error from this source, which is known as the *error of capacity*, is lessened.

The *height* of the barometer is the distance between the levels of the mercury in the tube and in the cistern. Hence the barometer should always be perfectly vertical; for if not, the tube being inclined, the column of mercury is elongated (fig. 153), and the number read off on the scale is too great. As the pressure which the mercury exerts by its weight at the base of the tube is independent of the form of the tube and of its diameter (100), provided it is not capillary, the height of the barometer is independent of the diameter of the tube and of its shape, but is inversely as the density of the liquid. With mercury the mean height at the level of the sea is 29.92, or, in round numbers, 30 inches; in a water barometer it would be about 34 feet, or 10.33 metres.

In *marine barometers* the error of capacity is got rid of by graduating the scale, not in the true measurements, but by an empirical correction depending

on the relative diameters of the tube and cistern. Thus if a rise of 10 mm. in the tube produced a fall of 1 mm. in the cistern, the true change would not be 10 mm. but 11 mm. This is obviously allowed for by dividing the space of 10 mm. on the scale into 11 mm. The correctness of such an instrument depends on the accuracy with which the scale is laid off.

168. **Fortin's barometer.**—*Fortin's barometer* differs in the shape of the cistern from that just described. The base of the cistern is made of



Fig. 152

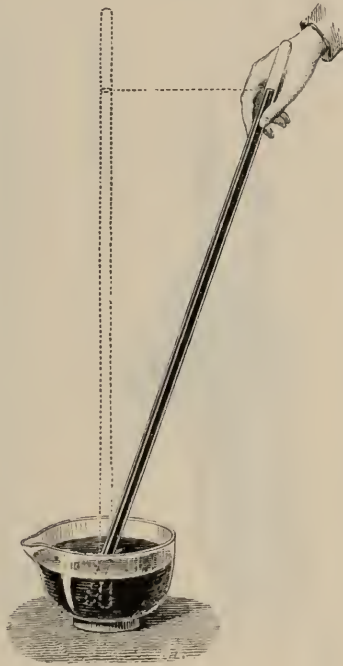

Fig. 153



Fig. 154

leather, and can be raised or lowered by means of a screw; this arrangement has the advantage that a constant level can be obtained, and also that the instrument is made more portable. For, in travelling, it is only necessary to raise the leather until the mercury, which rises with it, quite fills the cistern and the tube; the barometer may then be inclined, and even inverted, without any fear that a bubble of air may enter, or that the shock of the mercury may crack the tube.

Fig. 154 represents the arrangement of the barometer, the tube of which

is placed in a brass case. At the top of this case there are two longitudinal slits on opposite sides, so that the level of the mercury, B, is seen. The scale on the case is graduated in millimetres. An index, A, moved by the hand, gives by means of a vernier the height of the mercury to $\frac{1}{20}$ th of a millimetre. At the bottom of a case is the cistern, *b*, containing mercury, *a*.

Fig. 155 shows the details of the cistern on a larger scale. It consists of a glass cylinder, *b*, through which the mercury can be seen; this is closed at the top by a boxwood disc fitted on the under surface of the brass cover M. Through this passes the barometer tube E, which is drawn out at the end, and dips in the mercury; the cistern and the tube are connected by a piece of buckskin, *ce*, which is firmly tied at *c* to a contraction in the tube, and at *e*

to a brass tubulure in the cover of the cistern. This mode of closing prevents the mercury from escaping when the barometer is inverted, while the pores of the leather transmit the atmospheric pressure. The bottom of the cylinder *b* is cemented on a boxwood cylinder, *zz*, on a contraction in which, *ii*, is firmly tied the buckskin, *mn*, which forms the base of the cistern. On this skin is fastened a wooden button, *x*, which rests against the end of a screw, C. According as this is turned in one direction or the other the skin *mn* is raised or lowered, and with it the mercury. In using this barometer the mercury is first made exactly level with the point *a*, which is effected by turning the screw C either in one direction or the other. The graduation of the scale is counted from this point *a*, and thus the distance of the top of the column of

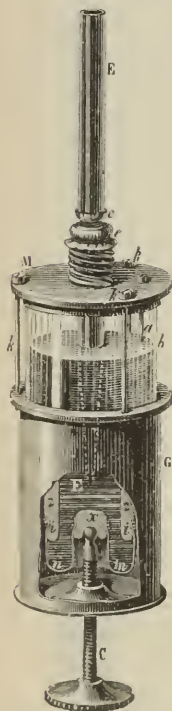

Fig. 155

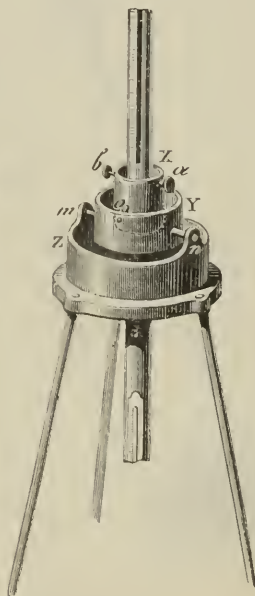

Fig. 156

mercury from *a* gives the height of the barometer. The bottom of the cistern is surrounded by a brass case, which is fastened to the cover M by screws, *k, k, k*. We have already seen (167) the importance of having the barometer quite vertical, which is effected by the following plan, known as *Cardan's suspension*.

The metal case containing the barometer is fixed in a copper sheath X by two screws, *a* and *b* (fig. 156). This is provided with two axles (only one of which, *a*, is seen in the figure), which turn freely in two holes in a ring, Y.

In a direction at right angles to that of the axes, oo , the ring has also two similar axes, m and n , resting on a support, Z . By means of this double suspension the barometer can oscillate freely about mm and oo , in two directions at right angles to each other. Care is taken that the intersections of these axes of suspension lie on the vertical axis of the tube and above the centre of gravity of the suspended system, and consequently that the barometer is perfectly vertical.

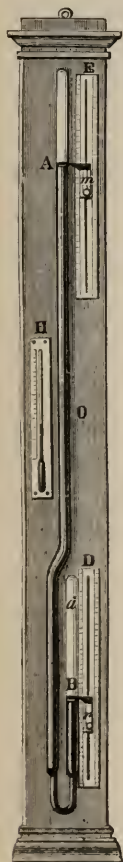

Fig. 157



Fig. 158



Fig. 159

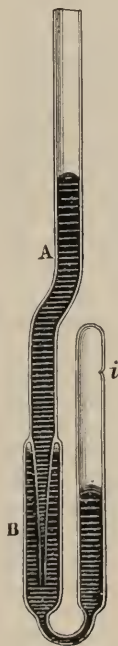

Fig. 160

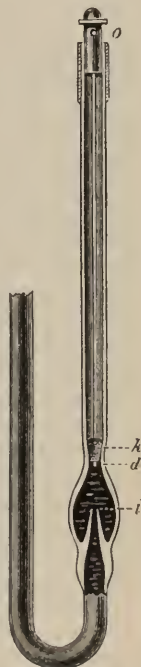

Fig. 161

169. **Gay-Lussac's siphon barometer.**—The siphon barometer is a bent glass tube, one of the branches of which is much longer than the other. The longer branch, which is closed at the top, is filled with mercury as in the cistern barometer; while the shorter branch, which is open, serves as a cistern. The difference between the two levels is the height of the barometer.

Fig. 157 represents the siphon barometer as modified by Gay-Lussac.

In order to render it more available for travelling, by preventing the entrance of air, he joined the two branches by a capillary tube (fig. 158); when the instrument is inverted (fig. 159) the tube always remains full in virtue of its capillarity, and air cannot penetrate into the longer branch. A sudden shock, however, might separate the mercury and admit some air. To avoid this, Bunten introduced an ingenious modification into the apparatus. The longer branch is drawn out to a fine point, and is joined to a tube, B, of the form represented in fig. 160. This arrangement forms an *air-trap*; for if air passes through the capillary tube it cannot penetrate the drawn-out extremity of the longer branch, but lodges in the upper part of the enlargement B. In this position it does not affect the observations, since the vacuum is always at the upper part of the tube; it is, moreover, easily removed.

In the siphon barometer the shorter branch is closed, but there is a capillary aperture in the side *i*, through which the atmospheric pressure is transmitted.

The barometric height is determined by means of two scales, which have a common zero at O, towards the middle of the longer branch, and are graduated in contrary directions, the one from O to E, and the other from O to B, either on the tube itself, or on brass rules fixed parallel to the tube. Two sliding verniers, *m* and *r*, indicate tenths of a millimetre. The total height of the barometer, AB, is the sum of the distances from O to A and from O to B.

Fig. 161 represents a very convenient mode of arranging the open end of a siphon barometer for transport. The quantity of mercury is so arranged that when the Torricellian space is quite filled with mercury, by inclining the tube the enlargement is just filled to *d*. This is closed by a carefully fitted cork, fixed on the end of a glass tube, *do*, about a millimetre in diameter, which allows for the expansion of mercury by heat. When the barometer is to be used, the cork and tube are raised.

In marine barometers, in order to prevent violent oscillations of the mercury and the possible breaking of the tube by the impact of the mercury on the upper end, the tube is contracted at one part so as to have a capillary diameter. The friction in this fine part is so great that ten or fifteen minutes elapse, when the tube is inclined, before the mercury creeps up to the end of it. These barometers are also provided, as are all standard barometers, with air-traps.

170. Precautions in reference to barometers.—In the construction of barometers mercury is chosen in preference to any other liquid, since, being the densest of all liquids, it stands at the least height. When the mercury barometer stands at 30 inches, the water barometer would stand at about 34 feet (167). It also deserves preference because it does not moisten the glass, and further because of its low vapour pressure. It is necessary that the mercury be pure and free from oxide, otherwise it adheres to the glass and tarnishes it. Moreover, if it is impure, its density is changed, and the height of the barometer is too great. Mercury is purified, before being used for barometers, by treatment with dilute nitric acid, and by distillation.

The space at the top of the tube (figs. 152 and 157), which is called the *Toricellian vacuum*, must be quite free from air and from aqueous vapour,

for otherwise either would depress the mercurial column by its elastic force. To obtain this result, a small quantity of pure mercury is placed in the tube and boiled for some time. It is then allowed to cool, and a further quantity, previously warmed, added, which is boiled, and so on, until the tube is quite full; in this manner the moisture and the air which adhere to the sides of the tube (195) pass off with the mercurial vapour. A barometer tube should not be too narrow, for otherwise the mercury moves sluggishly; and before a reading is taken, the barometer should be tapped so as to get rid of the adhesion to the glass.

A barometer is free from air and moisture if, when it is inclined, the mercury strikes with a sharp metallic sound against the top of the tube. If there is air or moisture in it, the sound is deadened.

171. **Correction for capillarity.**—In cistern barometers there is always a certain depression of the mercurial column due to capillarity. The correction to be made for this depression depends upon the diameter of the tube, and may be neglected when the diameter exceeds $\cdot 8$ inch. For a tube a quarter of an inch in diameter, the correction to be applied (i.e. *added* to the observed height) is approximately $\cdot 017$ inch.

In the siphon barometer the two tubes are of the same diameter, so that the error caused by the depression in the one tube very nearly corrects that caused by the depression in the other. As, however, the meniscus in the one tube is formed by a column of mercury with an ascending motion, while that in the other is formed by a column with a descending motion, and as further the mercury in one tube is clean while in the other it is exposed to the air and becomes dusty and oxidised, the correction cannot be quite exact.

172. **Correction for temperature.**—In all observations with barometers, whatever be their construction, a correction must be made for temperature. Mercury contracts and expands with change of temperature, hence its density changes, and consequently the barometric height for a given pressure is inversely as the density of the mercury, so that for different atmospheric pressures the mercurial column might have the same height. Accordingly, in each observation the height observed must be reduced to a standard temperature. The choice of this is quite arbitrary, but that of melting ice is always adopted in practice. It will be seen in the book on Heat how this correction is made.

173. **Variations in the height of the barometer.**—When the barometer is observed for several days, its height, corrected for temperature, is found to vary in the same place, not only from one day to another, but also during the same day.

The extent of these variations—that is, the difference between the greatest and the least height—is different in different places. It increases from the Equator towards the Poles. Except under extraordinary conditions, the greatest variations do not exceed 6 mm. under the Equator, 30 mm. under the tropic of Cancer, 40 mm. in France, and 60 mm. at 25 degrees from the Pole. The greatest variations are observed in winter.

The *mean daily height* is the height obtained by dividing the sum of 24 successive hourly observations by 24. In our latitudes the barometric height at noon corresponds to the mean daily height. The *mean monthly height*

is obtained by adding together the mean daily heights for a month and dividing by 30. The *mean yearly height* is similarly obtained.

Under the Equator the mean annual height at the level of the sea is 758 mm., or 29·84 inches. It increases from the Equator, and between the latitudes 30° and 40° it attains a maximum of 763 mm., or 30·04 inches. In lower latitudes it decreases, and in Paris it does not exceed 756·8 mm.

The general mean at the level of the sea is 761 mm., or 29·96 inches.

The mean monthly height is greater in winter than in summer, in consequence of the cooler atmosphere.

Two kinds of variations are observed in the barometer : 1st, the *accidental variations*, which present no regularity ; they depend on the seasons, the direction of the winds, and the geographical position, and are common in our climates ; 2nd, the *daily variations*, which are produced periodically at certain hours of the day.

At the Equator, and between the tropics, no accidental variations are observed ; but the daily variations take place with such regularity that a barometer may serve to a certain extent as a clock. The barometer sinks from midday till towards four o'clock ; it then rises, and reaches its maximum at about ten o'clock in the evening. It then again sinks, and reaches a second minimum towards four o'clock in the morning, and a second maximum at ten o'clock. In the temperate zones there are also daily variations, but they are detected with difficulty, since they occur in conjunction with accidental variations.

The hours of the maxima and minima appear to be the same in all climates, whatever be the latitude ; they merely vary a little with the seasons.

174. **Causes of barometric variations.**—It is observed that the course of the barometer is generally in the opposite direction to that of the thermometer ; that is, that when the temperature rises the barometer falls, and *vice versa* ; which indicates that the barometric variations at any given place are produced by the expansion or contraction of the air, and therefore by its change in density. If the temperature were the same throughout the whole extent of the atmosphere, no currents would be produced, and at the same height atmospheric pressure would be everywhere the same. But when any portion of the atmosphere becomes warmer than the neighbouring parts its specific gravity is diminished, and it rises and passes away through the upper regions of the air, whence it follows that the pressure is diminished and the barometer falls. If any portion of the atmosphere retains its temperature, while the neighbouring parts become cooler, the same effect is produced ; for in this case, too, the density of the first-mentioned portion is less than that of the others. Hence, also, it usually happens that an extraordinary fall of the barometer at one place is counterbalanced by an extraordinary rise at another place. The daily variations appear to result from the expansions and contractions which are periodically produced in the atmosphere by the heat of the sun during the rotation of the earth.

175. **Relation of barometric variations to the state of the weather.**—It has been observed that, in our climate, the barometer in fine weather is generally above 30 inches, and is below this point when there is rain, snow, wind, or storm ; and also, that for any given number of days at which the

barometer stands at 30 inches there are as many fine as rainy days. From this coincidence between the height of the barometer and the state of the weather, the following indications have been marked on the barometer, counting by thirds of an inch above and below 30 inches :—

Height	State of the weather
31 inches	Very dry.
30 $\frac{2}{3}$ "	Settled weather.
30 $\frac{1}{3}$ "	Fine weather.
30 "	Variable.
29 $\frac{2}{3}$ "	Rain or wind.
29 $\frac{1}{3}$ "	Much rain.
29 "	Tempest.

In using the barometer as an indicator of the state of the weather, we must not forget that it really only serves to measure the pressure of the atmosphere, and that it only rises or falls as the pressure increases or diminishes ; and although a change of weather frequently coincides with a change in the pressure, they are not necessarily connected. This coincidence arises from meteorological conditions peculiar to our climate, and does not occur everywhere. That fall in the barometer usually precedes rain in our latitudes is caused by the position of Europe. The prevailing winds here are the south-west and north-east. The former, coming to us from the equatorial regions, are warmer and lighter. They often, therefore, blow for hours or even days in the higher regions of the atmosphere before manifesting themselves on the surface of the earth. The air is therefore lighter, and the pressure lower. Hence a fall of the barometer is a probable indication of the south-west winds, which gradually extend downwards, and, reaching us, after having traversed large tracts of water, are charged with moisture, and bring us rain.

The north-east wind blows simultaneously above and below, but the hindrances to the motion of the current on the earth, by hills, forests, and houses, cause the upper current to be somewhat in advance of the lower ones, though not so much so as the south-west wind. The air is therefore somewhat heavier even before we perceive the north-east, and a rise in the barometer affords a forecast of the occurrence of this wind, which, as it reaches us after having passed over the immense tracts of dry land in Central and Northern Europe, is mostly dry.

When the barometer rises or sinks slowly, that is, for two or three days, towards fine weather or towards rain, it has been found from a great number of observations that the indications are then extremely probable. Sudden variations in either direction indicate bad weather or wind.

176. **Wheel barometer.**—The *wheel barometer*, which was invented by Hooke, is a siphon barometer, and is especially intended to indicate good and bad weather (fig. 162). In the shorter leg of the siphon there is a float which rises and falls with the mercury. A string attached to this float passes round a pulley, and at the other end there is a weight somewhat lighter than the float. A needle fixed to the pulley moves round a graduated circle, on which is marked *stormy, rain, set fair*, &c. When the

pressure varies the float sinks or rises, and moves the needle round to the corresponding points on the scale.

The barometers ordinarily met with in houses, which are called *weather-glasses*, are of this kind. They

are, however, of little use, for two reasons. The first is, that they are neither very delicate nor very accurate in their indications. The second, which applies equally to all barometers, is that those commonly in use in this country are made in London, and the indications, if they are of any value, are only so for a place of the same level above the sea as London. Thus a barometer standing at a certain height in London would indicate a certain state of weather, but if removed to Shooter's Hill it would stand half an inch lower, and would indicate a different state of weather. As the pressure differs with the level and with geographical conditions, it is necessary to take these into account if exact data are wanted.

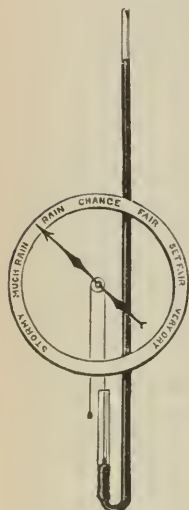

Fig. 162



Fig. 163

177. **Fixed barometer.**—For accurate observations Regnault used a barometer the height of which he measured by means of a cathetometer (87). The cistern (fig. 163) is of cast iron; against the frame on which it is supported a screw is fitted, which is pointed at both ends, and the length of which has been determined, once for all, by the cathetometer. To measure the barometric height,

the screw is turned until its point grazes the surface of the mercury in the bath, which is the case when the point and its image are in contact. The distance then from the top of the point to the level of the mercury in the tube b is measured by the cathetometer, and this, together with the length of which has been determined, once for all, by the cathetometer. To measure the barometric height, the screw is turned until its point grazes the surface of the mercury in the bath, which is the case when the point and its image are in contact. The distance then from the top of the point to the level of the mercury in the tube b is measured by the cathetometer, and this, together with the length of which has been determined, once for all, by the cathetometer. This barometer has, moreover, the advantage that, as a tube an inch in diameter may be used, the influence of capillarity becomes inappreciable. Its construction, moreover, is very simple; it has no scale, and any errors in reading the barometric height are those which are incidental to the cathetometer. Unfortunately, the latter instrument requires great accuracy in its construction, and is expensive.

178. **Glycerine barometer.**—Jordan constructed a barometer in which the

liquid used is pure glycerine. This has the specific gravity 1.26, and therefore the length of the column of liquid is rather more than ten times that of mercury; hence small alterations in the atmospheric pressure produce considerable changes in the height of the liquid. The tube consists of ordinary composition gas-tubing about $\frac{5}{8}$ of an inch in diameter and 28 feet or so in length; the lower end is open and dips in the cistern, which may be placed in a cellar; the top is sealed to a closed glass tube an inch in diameter, in which the fluctuations of the column are observed. This may be arranged in an upper story, and the tubing, being easily bent, lends itself to any adjustment which the locality requires.

The vapour of glycerine has a very low pressure at ordinary temperatures, and the change of pressure with ordinary changes of atmospheric temperature is insignificant. On the other hand, it readily attracts moisture from the air, whereby the density, and therewith the height, of the liquid column varies. Absorption of aqueous vapour is prevented by covering the liquid in the cistern with a layer of paraffin oil.

The 'Philosophical Magazine,' vol. xxx. Fourth series, page 349, contains a detailed account of a method of constructing a water barometer.

179. **Determination of heights by the barometer.**—Since the atmospheric pressure decreases as we ascend, it is obvious that the barometer will keep on falling as it is taken to a greater and greater height. On this depends a method of determining the difference between the heights of two stations, such as the base and summit of a mountain. The method may be explained as follows:—

According to Boyle's law (181), if the temperature of an enclosed portion of air is constant, its volume will vary inversely as the pressure; that is to say, if we double the pressure we shall halve the volume. But if we halve the volume we manifestly double the quantity of air in each cubic inch—that is to say, we double the density of the air; and so on in any proportion. Consequently the law is equivalent to this:—*That for a constant temperature the density of air is proportional to the pressure which it sustains.*

Now suppose A and B (fig. 164) to represent two stations, and that it is required to determine the vertical height of B above A, it being borne in mind that A and B are not necessarily in the same vertical line. Take P, any point in AB, and Q, a point at a small distance above P, and consider a small rectangular volume of air between P and Q, its height being PQ and its horizontal area 1 square inch. This volume is in equilibrium because its weight, acting downwards, is equal to the difference of pressure on its upper and lower faces acting upwards. We can write down an equation representing this equality, and, by the Integral Calculus, sum up the various differences of pressure due to differences of height of all points between A and B. We thus arrive at the following expression:—

$$kgX = \log \frac{P}{P_1} = \log \frac{H}{H_1},$$

where X is the vertical distance between A and B, P and P₁ the pressures, and H and H₁ the barometric heights at A and B, g the acceleration of

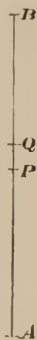

Fig. 164

gravity which is different at different parts of the earth, and k a constant depending on the relation between the density of air and its temperature and pressure.

Putting in the proper values for these symbols, we arrive, after certain reductions, at the formula.

$$X \text{ (in feet)} = 60346(1 + 0.00256 \cos 2\phi) \left(1 + 2 \frac{(T + T_1)}{1000} \right) \log_{10} \frac{H}{H_1},$$

which is Laplace's barometric formula. In using it we must remember that T and T_1 are temperatures on the Centigrade thermometer at the lower and upper stations, and that H and H_1 are the heights of the barometer reduced to 0°C. , and ϕ is the latitude.

For heights not exceeding 2000 feet we may, without much error, use the formula

$$X \text{ (in feet)} = 52500 \left(1 + 2 \frac{(T + T_1)}{1000} \right) \times \frac{H - H_1}{H + H_1}.$$

180. **Ruhlmann's observations.**—The results obtained for the difference in height of places by using the above formula often differ from the true heights, as measured trigonometrically, to an extent which cannot be ascribed to errors in observation. The numbers thus found for the height of places are influenced by the time of day, and also by the season of year, at which they are made. Ruhlmann has investigated the cause of this discrepancy by a series of direct barometric and thermometric observations made at two different stations in Saxony, and also by a comparison of the continuous series of observations made at Geneva and on the St. Bernard.

Ruhlmann thus ascertained that the cause of the discrepancy is to be found in the fact that the mean of the temperatures indicated by the thermometer at the two stations is not an accurate measure of the actual mean temperature of the column of air between the two stations—a condition which is assumed in the above formula. The variations in the temperature of the column of air are not of the same extent as those indicated by the thermometer, nor do they follow them so rapidly; they drag after them, as it were. If the mean monthly temperatures at the two fixed stations are introduced into the formula, they give in winter heights which are somewhat too low, and in summer such as are too high. The results obtained by introducing the mean yearly temperature of the two stations are very near the true ones.

This influence of temperature is most perceptible in individual observation of low heights. Thus, using the observed temperatures in the barometric formula, the error in height of the Uetliberg above Zürich (about 1700 feet) was found to be $\frac{1}{2.3}$ of the total, while the height of the St. Bernard above Geneva was found within $\frac{1}{1.35}$ of the true height.

The reason why the thermometers do not indicate the true temperature of the air is undoubtedly that they are too much influenced by radiation from the earth and surrounding bodies. The earth is highly absorbent, and becomes rapidly heated under the influence of the sun's rays, and becomes as rapidly cooled at night; the air, as a very diathermanous body, is but little heated by the sun's rays, and on the contrary is little cooled by radiation during the night.

CHAPTER II

MEASUREMENT OF THE ELASTIC FORCE OF GASES

181. **Boyle's law.**—The law of the compressibility of gases was discovered by Boyle in 1662, and afterwards independently by Mariotte in 1679. It is in England commonly called 'Boyle's Law,' and, on the Continent, 'Mariotte's Law.' It is as follows :—

The temperature remaining the same, the volume of a given quantity of gas is inversely as the pressure which it bears.

This law may be verified by means of an apparatus devised by Boyle (fig. 165). It consists of a long glass tube fixed to a vertical support ; it is open at the upper part, and the other end, which is bent into a short vertical leg, is closed. On the shorter leg there is a scale which indicates equal capacities ; the scale against the long leg gives the heights. The zero of both scales is in the same horizontal line.

A small quantity of mercury is poured into the tube, so that its level in both branches is at zero, which is effected without much difficulty after a few trials (fig. 165). The air in the short leg is thus under the ordinary atmospheric pressure, which is exerted through the open tube. Mercury is then poured into the longer tube until the volume of the air in the smaller tube is reduced to one-half ; that is, until it is reduced from 10 to 5, as shown in fig. 166. If the height of the mercurial column CA is measured, it will be found exactly equal to the height of the barometer at the time of the experiment. The pressure of the column CA is therefore equal to an atmosphere, and therefore the air in CB is subjected to a pressure of two atmospheres. Accordingly, by doubling the pressure, the volume of the gas has been diminished to one-half.

If mercury is poured into the longer branch until the volume of the air is reduced to one-third, it will be found that the distance between the level of the two tubes is equal to twice the barometric height. The pressure is now 3 atmospheres, while the volume is reduced to one-third. Dulong and Petit verified the law for air up to 27 atmospheres, by means of an apparatus analogous to that which has been described.

The law also holds good in the case of pressures of less than one atmosphere. To establish this, mercury is poured into a graduated tube until it is about two-thirds full, the rest being air. It is then inverted in a deep trough M, containing mercury (fig. 167), and lowered until the levels of the mercury inside and outside the tube are the same, and the volume AB noted. The tube is then raised, as represented in the figure, until the volume of air AC is double that of AB (fig. 168). The height of the mercury in the tube

above the mercury in the trough CD is then found to be exactly half the height of the barometric column. The air whose volume is now doubled is only under the pressure of half an atmosphere; for its pressure is equal to atmospheric pressure minus that due to the column CD. If the tube is further raised until AC is three times AB, CD will be found to be equal to two-thirds of the height of the barometer, *i.e.* the pressure which AC bears is now one-third of an atmosphere. Accordingly the volume is inversely as the pressure.

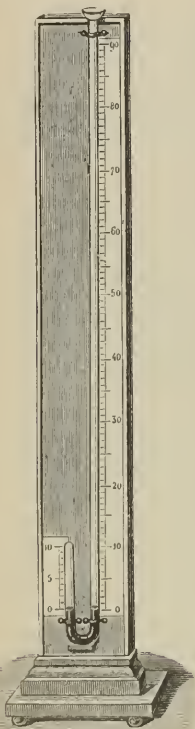

Fig. 165

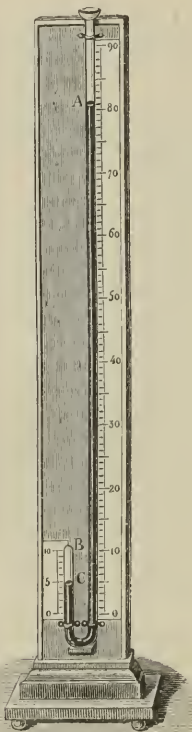

Fig. 166

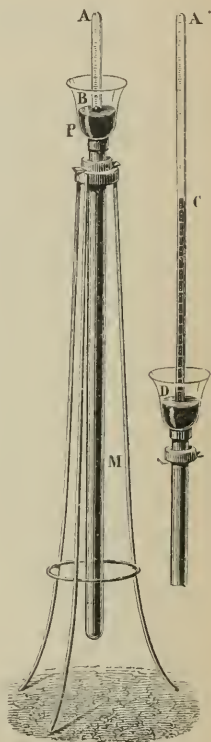

Fig. 167

Fig. 168

In general, if V is the original volume of a gas under the pressure P , and V' the volume of the same gas under another pressure P' , we have the ratio

$$V : V' = P' : P \text{ or } VP = V'P'.$$

This may be expressed by saying that, *the temperature of a given mass of gas being constant*, the product of pressure and volume is constant; that is,

$$PV = \text{const.}$$

In the experiment with Boyle's tube, as the mass of air remains the

same, its density must obviously increase as its volume diminishes, and *vice versa*. The law may thus be enunciated:—‘For the same temperature the density of a gas is proportional to its pressure.’ Hence, as water is 773 times as heavy as air, under a pressure of 773 atmospheres air would be as dense as water, supposing the law to hold good for so high a pressure.

182. **Boyle's law is only approximately true.**—Until within comparatively recent times Boyle's law was supposed to be absolutely true for all gases at

all pressures, but Despretz obtained results incompatible with the law. He took two graduated glass tubes of the same length, and filled one with air and the other with the gas to be examined. These tubes were placed in the same mercury trough, and the whole apparatus immersed in a strong glass cylinder filled with water. By means of a piston moved by a screw which worked in a cap at the top of a cylinder, the liquid could be subjected to an increasing pressure, and it could be seen whether the compression of the two gases was the same or not. The apparatus resembled that used for examining the compressibility of liquids (fig. 73). In this manner Despretz found that carbonic acid, sulphuretted hydrogen, ammonia, and cyanogen are more compressible than air: hydrogen, which has the same compressibility as air up to 15 atmospheres, is then less compressible. From these experiments it was concluded that the law of Boyle was not general.

In some experiments on the elastic force of vapours, Dulong and Arago had occasion to test the accuracy of Boyle's law. The method adopted was exactly that of Boyle, but the apparatus had gigantic dimensions.

The gas to be compressed was contained in a strong glass tube, GF (fig. 169), about six feet long and closed at the top, G. The pressure was produced by a column of mercury, which could be increased to a height of

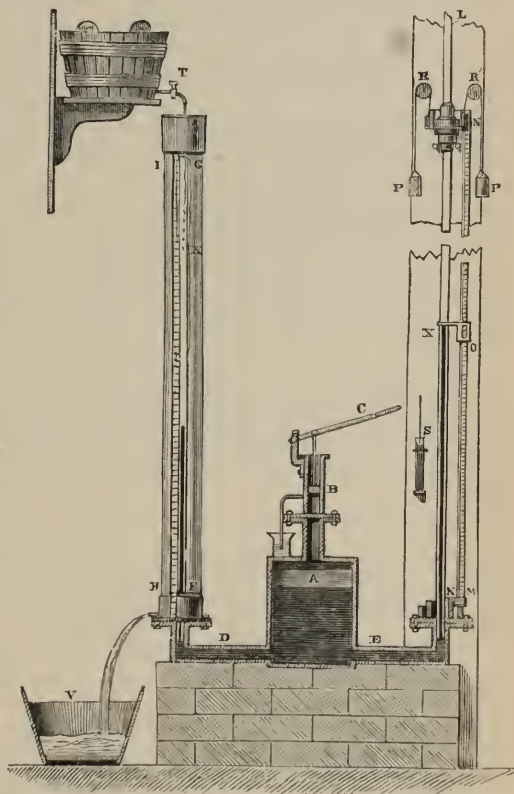

Fig. 169

65 feet, contained in a long, vertical tube, KL, formed of a number of tubes firmly joined by good screws, so as to be perfectly tight.

The tubes KL and GF were hermetically fixed in a horizontal iron pipe, DE, which formed part of a mercurial reservoir, A. On the top of this reservoir there was a force-pump, BC, by which mercury could be forced into the apparatus.

At the commencement of the experiment the volume of the air in the tube GF (fig. 169) was observed, and the initial pressure determined, by adding to the pressure of the atmosphere the height of the mercury in KL above its level in GF. If the level of the mercury in the air tube had been above the level in KL, it would have been necessary to subtract the difference.

By means of the pump, water was injected into A. The mercury, being then pressed by the water, rose in the tube GF, where it compressed the air, and in the tube KL, where it rose freely. It was only then necessary to measure the volume of the air in GF; the height of mercury in KL above the level in GF, together with the pressure of the atmosphere, was the total pressure to which the gas was exposed. These were all the elements necessary for comparing different volumes and the corresponding temperatures. The tube GF was kept cold during the experiment by a stream of cold water.

The long tube was attached to a long mast by means of staples. The individual tubes were supported at the junction by cords, which passed round pulleys, R and R¹, and were kept stretched by small buckets, P, containing shot. In this manner each of the thirteen tubes having been separately counterpoised, the whole column was perfectly free notwithstanding its weight.

Dulong and Arago experimented with pressures up to 27 atmospheres, and observed that the volume of air always diminished a little more than is required by Boyle's law. But as these differences were very small, they attributed them to errors of observation, and concluded that the law was perfectly exact, at any rate up to 27 atmospheres.

The experiments of Regnault (1847) on the same subject were distinguished by the extreme care and attention to small sources of error with which they were carried out. The apparatus used was similar to that already described, but the tube containing the gas under examination, instead of being closed at the top as in the experiments of his predecessors, was connected with the reservoir of the gas and with a force-pump. Experiments were conducted in such a way that the pressure was observed when the gas filled the tube and also when the volume was reduced by compression to about half. If P, V are the pressure and volume of the gas when filling the tube, and P_1, V_1 the corresponding values for the half tube, $PV = P_1V_1$, supposing Boyle's law to hold. If $\frac{PV}{P_1V_1} > 1$, or $\frac{PV}{P_1V_1} = 1 + \epsilon$, the gas is more compressible than Boyle's law requires. If $\frac{PV}{P_1V_1} < 1$, or $\frac{PV}{P_1V_1} = 1 - \epsilon$, the gas is less compressible than it would be in accordance with the law.

The following table gives the results of a series of experiments made on air, nitrogen, carbonic acid, and hydrogen :—

Air		Nitrogen		Carbonic Acid		Hydrogen	
P_0	$\frac{P_0 V_0}{P_1 V_1}$	P_0	$\frac{P_0 V_0}{P_1 V_1}$	P_0	$\frac{P_0 V_0}{P_1 V_1}$	P_0	$\frac{P_0 V_0}{P_1 V_1}$
mm.		mm.		mm.		mm.	
738 ⁷²	1 ⁰⁰ 1414	753 ⁴⁶	1 ⁰⁰⁰ 988	764 ⁰³	1 ⁰⁰⁷ 597	—	—
2112 ⁵³	1 ⁰⁰² 765	4953 ⁹²	1 ⁰⁰² 952	3486 ¹³	1 ⁰²⁸ 698	2211 ¹⁸	0 ⁹⁹⁸ 584
4140 ⁸²	1 ⁰⁰³ 253	8628 ⁵⁴	1 ⁰⁰⁴ 768	4879 ⁷⁷	1 ⁰⁴⁵ 625	5345 ¹⁸	0 ⁹⁹⁶ 121
9336 ⁴¹	1 ⁰⁰⁶ 366	10981 ⁴²	1 ⁰⁰⁶ 456	9619 ⁹⁷	1 ¹⁵⁵ 865	9176 ⁵⁰	0 ⁹⁹² 933

Regnault's conclusions were—

1. That no gas rigorously obeys Boyle's law. The divergence is small for small pressures, but increases with the pressure.

2. That ϵ is positive for all the gases experimented on except hydrogen. Hydrogen then is less compressible, all the other gases more compressible, than Boyle's law requires.

3. The divergence from the law is greater for the easily liquefiable gases, such as carbonic acid, sulphurous acid, ammonia, and cyanogen, than for the gases called in Regnault's time *permanent* gases, viz. oxygen, nitrogen methane, nitric oxide, and carbon monoxide.

Thus to reduce air to $\frac{1}{20}$ of its original volume, a pressure of 19.7199 atmospheres was required instead of 20; and while carbonic acid only required 16.705, hydrogen required 20.269 atmospheres.

Very much higher pressures have been employed in similar experiments by Natterer and by Andrews. Natterer's experiments showed that air, oxygen, nitrogen, and carbonic oxide are for moderate pressures more compressible and for high pressures less compressible than in accordance with Boyle's law. Andrews's experiments will be described later (373). Cailletet used a special apparatus by which the pressure could be raised to 600 atmospheres.

Amagat made a remarkable series of experiments by a method based on Boyle's experiment. The pressure could be applied directly by means of mercury in a steel tube about 1300 feet in length, arranged in the shaft of a deep coalpit, and suitably connected at the bottom with a carefully calibrated glass compression tube. In this way pressures of as much as 500 atmospheres could be applied; the temperatures were kept constant by surrounding the compression tube by a jacket through which water circulated.

The general result of these experiments is exhibited by the curves in fig. 170, which are plotted with pressures as abscissæ and the products PV as ordinates. Were Boyle's law true for these gases, the curves would be straight lines parallel to the axis of pressures. The curves show that PV diminishes at first for all the gases examined (except hydrogen). The deviation from Boyle's law reaches a maximum, different for different gases, and then diminishes; further, that at a certain pressure (which for atmospheric air is 175 atmospheres, or a little over one ton weight per square inch) each gas accurately obeys Boyle's law. From this point the deviation from the law is in the same direction as that exhibited by hydrogen, and appears to increase indefinitely with the pressure.

The newly discovered gas *helium* behaves under ordinary pressures like hydrogen, *i.e.* it is not so compressible as Boyle's law requires.

Experiments have been made as to the validity of Boyle's law for pressures much lower than one atmosphere, but the variations observed are within the errors of observation.

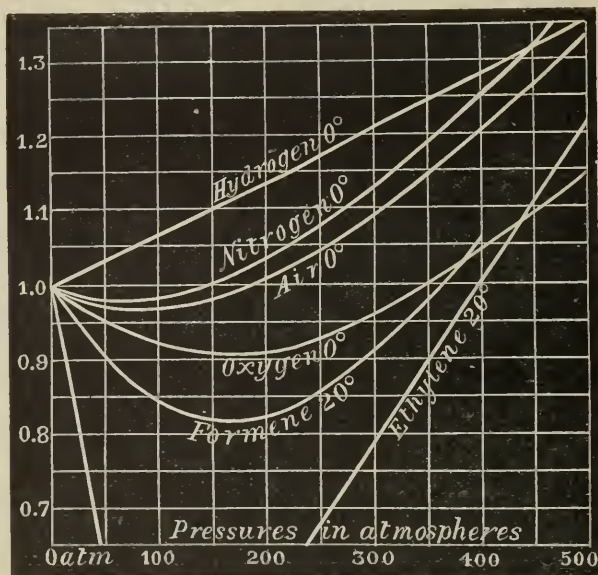

Fig. 170

183. **Van der Waals' formula.**—Under high pressures gases do not, as we have seen, follow Boyle's law with strictness. In order to account for these discrepancies Van der Waals has introduced a modification into the formula $PV = \text{const.}$ (181) which is based on the following considerations. Suppose the molecules of the gas attract each other, and that the attraction is greater the nearer the molecules are together. When the volume of the gas is diminished by the application of external pressure, the mean distance between molecule and molecule diminishes, and the mutual attraction consequently increases. Thus the molecules are drawn together not only by the externally applied pressure, but by that due to their mutual attraction, and the diminution of volume is such that the actual pressure to which the gas is subjected may be regarded as equal to $P + p$, where P is the applied pressure and p that due to attraction. This additional pressure p will be proportional to the number of attracting particles and hence to the square of the density, or inversely proportional to the square of the volume. Suppose, however, that the force between the gaseous particles is one of repulsion instead of attraction. For a given reduction of volume (the temperature being always considered constant) the real pressure of the gas is less than that applied by the pressure due to molecular repulsion. Thus in any case the pressure of the gas may be written $P + \frac{a}{V^2}$, a being positive or negative

according as the molecular force is attractive or repulsive. Further, Boyle's formula assumes that the particles of a gas are mere points, so that with indefinitely increased pressure the volume would become indefinitely small. But the molecules of a gas must have *some* magnitude, and all that pressure can do is diminish the spaces between them and ultimately bring them into contact, beyond which point the volume could not be reduced. Thus, the volume of the gas which is capable of being reduced by pressure is not V but $V - b$, where b is the molecular volume or some multiple of it.

The formula of Boyle's law, as thus modified by Van der Waals, becomes

$$\left(P + \frac{a}{V^2}\right)(V - b) = \text{const.}$$

In the case of gases—oxygen, nitrogen, &c.—in which there is molecular attraction, a is positive, and (neglecting b for the moment) increase of pressure will produce a greater diminution of volume than corresponds to Boyle's law. But the effect of b (neglecting $\frac{a}{V^2}$ for the moment) will be, for a given pressure, to produce a smaller diminution than corresponds to Boyle's law. Thus the two effects oppose each other. With hydrogen and helium, on the other hand, for which a is negative, the two effects are additive and the gases are less compressible than Boyle's law requires. To go back to air, oxygen, &c., we see that at low pressures the product PV is less than that required by Boyle's law, and the influence of a preponderates; but as the pressure continuously increases, this influence diminishes in comparison with that of b , and the product now increases, and at high pressures the gases behave as does hydrogen at low pressures. Between these a maximum compressibility is seen, which varies with different gases according to the values of a and b in each case.

Van der Waals deduced from the experimental results obtained by Regnault for the comparison of various gases and for their expansion by heat, values for a and b for the respective gases, which when introduced into the formula satisfactorily represent the numbers obtained by experiment.

Thus for b in the case of hydrogen he obtained the number 0.00069; this is confirmed by Budde, who obtained 0.0007 by an entirely different method.

184. **Manometers.** — *Manometers* are instruments for measuring the pressure of gases or vapours. In all such instruments the unit chosen is the pressure of one atmosphere, or 30 inches of mercury at the standard temperature, which, as we have seen, is nearly 15 pounds to the square inch.

The *open-air manometer* consists of a bent glass tube BD (fig. 171), fastened to the bottom of a reservoir AC , of the same material, containing mercury, which is connected with the closed recipient containing the gas or vapour the pressure of which is to be measured. The whole is fixed on a long plank kept in a vertical position.

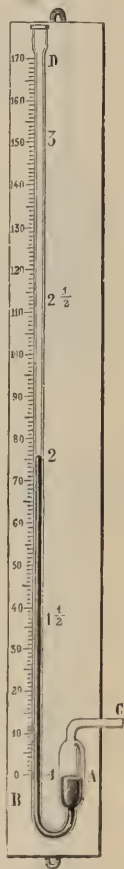

Fig. 171

In graduating this manometer, C is left open, and the number 1 marked at the level of the mercury, for this represents one atmosphere. From this point the numbers 2, 3, 4, 5, 6, are marked at each 30 inches, indicating so many atmospheres, since a column of mercury 30 inches represents a pressure of one atmosphere. In the graduation, allowance is made for the depression of the mercury at A as it rises in the tube. The intervals from 1 to 2, and from 2 to 3, &c., are divided into tenths. C being then placed in connection with a boiler, for example, the mercury rises in the tube BD to a height which measures the pressure of the vapour. In the figure the manometer marks 2 atmospheres, which represents a height of 30 inches or 76 cm. plus the atmospheric pressure exerted at the top of the column through the aperture D.



Fig. 172

This manometer is only used where the pressures do not exceed 5 to 6 atmospheres. Beyond this, the length of tube necessary makes it very inconvenient, and the following apparatus is commonly used.

185. **Manometer with compressed air.**—The *manometer with compressed air* is founded on Boyle's law: one form is represented in fig. 172, which may be screwed into a boiler or steam-pipe where pressure is to be measured. The pressure is transmitted through the opening *a* into the closed space *b*. In this is an iron vessel containing mercury, in which dips the open end of the manometer tube, which is screwed air-tight in the tubulure.

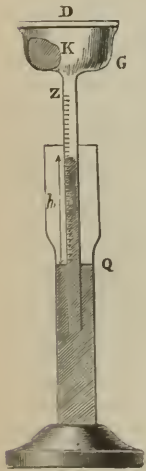

Fig. 173

In the graduation of this manometer, the quantity of air contained in the tube is such that when the aperture *a* communicates freely with the atmosphere, the level of the mercury is the same in the tube and in the tubulure. Consequently, at this level, the number 1 is marked on the scale to which the tube is affixed. As the pressure acting through the tubulure *a* increases, the mercury rises in the tube, until its pressure, added to that of the compressed air, is equal to the external pressure. It would consequently be incorrect to mark two atmospheres in the middle of the tube; for, since the volume of the air is reduced to one-half, its pressure is equal to two atmospheres, and, together with the weight of the mercury raised in the tube, is therefore more than two atmospheres. The position of the number is at such a height that the elastic force of the compressed air, together with the weight of the column of mercury in the tube, is equal to two atmospheres. The exact position of the numbers 2, 3, 4, &c. on the manometer scale can only be determined by calculation.

186. **Volumenometer.**—An interesting application of Boyle's law is met with in the *volumenometer*, which is used in determinations of the specific gravity of solids which cannot be brought into contact with water or other liquids. A simple form consists of a glass tube

with a cylinder, G, at the top (fig. 173), the edges of which are carefully ground, and which can be closed hermetically by means of a ground-glass plate D. The top being open, the tube is depressed until the level of the mercury inside and outside is at the mark Z. The apparatus is then closed airtight by the plate, and is raised until the mercury stands at a height, h , above the level Q, in the bath. The original volume of the enclosed air V, which was under the pressure of the atmosphere, is now increased to $V + v$, since the pressure has diminished by the height of the column of mercury h . Calling the height of the barometer at the time of observation b , we shall have $V : V + v = b - h : b$.

Placing now in the cylinder a body K, whose volume x is unknown, the same operations are repeated; the tube is raised until the mercury again stands at the same mark as before, but its height above the bath is now different; a second reading, h_1 , is obtained, and we have

$$(V - x) : (V - x) + v = b - h_1 : b.$$

Combining and reducing, we get $x = (V + v) \left(1 - \frac{h}{h_1}\right)$. The volume $V + v$ is constant, and is determined numerically, once for all, by making the experiment with a substance of known volume, such as a glass bulb.

This apparatus is also known as the *stercometer*. It is of great value in determining the *geometrical* or true *density* of gunpowder; this averages from 1.67 to 1.84, and is thus materially different from its *apparent density*, or the weight of a given volume compared with that of an equal volume of water, which is from 0.89 to 0.94.

187. **Regnault's barometric manometer.**—For measuring pressures of less than one atmosphere, Regnault devised the following arrangement, which is a modification of his fixed barometer (fig. 163). In the barometer cistern dips a second tube, a , of the same diameter, open at both ends, and provided at the top with a three-way cock, one aperture of which is connected with an air-pump and the other with the space to be exhausted. The further the exhaustion is carried the higher the mercury rises in the tube a . The differences of level in the tubes b and a give the pressures. Hence, by measuring the height, ab , by means of the cathetometer, the pressure in the space that is being exhausted is accurately given. This apparatus is also called a *differential barometer* or a *barometer gauge*.

188. **Aneroid barometer.**—This instrument derives its name from the circumstance that no liquid is used in its construction (*ἀν*, without; *νηρός*, moist). Fig. 174 represents one of the forms of this instrument; it consists of a cylindrical metal box, partially exhausted of air, the top of which is made of thin corrugated metal, so elastic that it readily yields to alterations in the pressure of the atmosphere.

When the pressure increases, the top is pressed inwards; when, on the contrary, it decreases, the elasticity of the lid, aided by a spring, tends to move it in the opposite direction. These motions are transmitted by delicate multiplying levers to an index which moves on a scale. The instrument is graduated empirically by comparing its indications, under different pressures, with those of an ordinary mercury barometer.

The aneroid has the advantage of being portable, and can be constructed

of such delicacy as to indicate the difference in pressure between the height of an ordinary table and the ground. It is hence much used in determining heights in mountain ascents. But it is somewhat liable to get out of order,

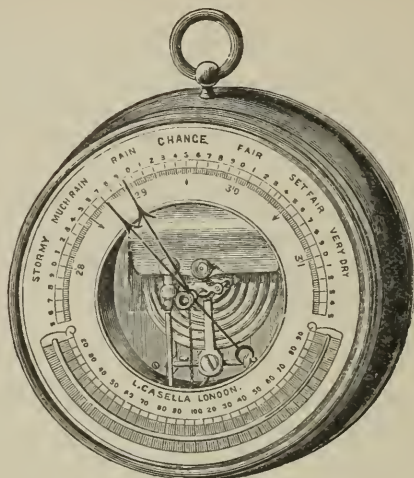

Fig. 174

especially when it has been subjected to great sudden variations of pressure; and its indications must from time to time be controlled by comparison with those of a standard barometer.

189. **Laws of the mixture of gases.**—If a communication is opened between two closed vessels containing gases, the gases at once begin to mix, whatever be their density, and in a longer or shorter time the mixture is complete, and will continue so unless chemical action is set up, each gas filling the whole available volume. The laws which govern the mixture of gases may be thus stated:—

I. *The mixture takes place rapidly and is homogeneous; that is, each portion of the mixture contains the two gases in the same proportion.*

II. *If the gases severally and the mixture occupy the same volume, and if the gases severally and the mixture exert the same pressure, then the pressure exerted by the mixture will equal the sum of pressures exerted by the gases severally.*

From the second law a very convenient formula can be easily deduced.

Let $v_1, v_2, v_3 \dots$ be the volumes of several gases under pressure of $p_1, p_2, p_3 \dots$ respectively. Suppose these gases when mixed to have a volume V , under a pressure P , the temperatures being the same. By Boyle's law we know that v_1 will occupy a volume V under a pressure p'_1 , provided that

$$Vp' = v_1p_1; \text{ similarly, } Vp'_2 = v_2p_2$$

and so on. But from the above law

$$P = p'_1 + p'_2 + \dots;$$

therefore

$$VP = v_1p_1 + v_2p_2 + v_3p_3 + \dots$$

It obviously follows that if the pressures are all the same, the volume of the mixture equals the sum of the separate volumes.

The first law was shown experimentally by Berthollet, by means of an apparatus represented in fig. 175. It consists of two glass globes provided with stopcocks, which can be screwed one on the other. The upper globe was filled with hydrogen, and the lower one with carbonic acid, which has 22 times the density of hydrogen, the pressure being the same in each. The globes, having been fixed together, were placed in the cellars of the Paris Observatory and the stopcocks then opened, the globe containing hydrogen being uppermost. After some time Berthollet found that the pressure had not changed, and that, in spite of the difference in density, the two gases had become uniformly mixed in the two globes. Experiments made in the same manner with other gases gave the same results, and it was found that the diffusion was more rapid in proportion as the difference between the densities was greater.

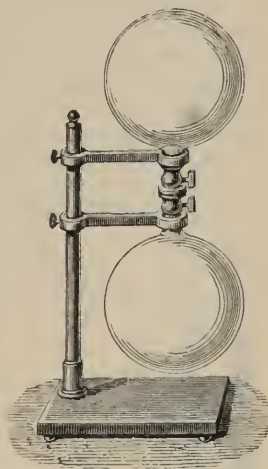

Fig. 175

The second law may be demonstrated by passing into a graduated tube, over mercury, known volumes of gas at known pressures. The pressure and volume of the whole mixture are then measured, and found to be in accordance with the law.

Gaseous mixtures follow Boyle's law, like simple gases, as has been proved for air (181), which is a mixture of nitrogen and oxygen.

190. **Absorption of gases by liquids.**—Water and many liquids possess the property of absorbing or dissolving gases. Under the same conditions of pressure and temperature a liquid does not absorb equal volumes of different gases. At the temperature 0° C. and pressure 760 mm., one volume of water dissolves the following volumes of gas :—

Nitrogen	0.020	Sulphuretted hydrogen	4.37
Oxygen	0.041	Sulphurous acid	79.79
Carbonic acid	1.79	Ammonia	1046.63

From the very great condensation observed, it may be inferred that the gases in solution are in the liquid state.

Gases are more soluble in alcohol than in water ; thus at 0° C. alcohol dissolves 4.33 times its own volume of carbonic acid gas.

The whole subject of gas absorption has been investigated by Bunsen. The general rules are the following :—

1. *For the same gas, the same liquid, and the same temperature, the weight of gas absorbed is proportional to the pressure.* This may also be expressed by saying that at all pressures the volume dissolved is the same ; or that the density of the gas absorbed is in constant relation with that of the external gas which is not absorbed.

Accordingly, when the pressure diminishes, the quantity of dissolved

gas decreases. If a solution of gas is placed under the receiver of an air-pump and the pressure is diminished, the gas obeys its expansive force, and escapes with effervescence.

II. *The quantity of gas absorbed decreases with increase of the temperature*; that is to say, when the elastic force of the gas is greater. Thus at 15° water absorbs only 1.00 of carbonic acid.

III. *The quantity of gas which a liquid can dissolve is independent of the nature and of the quantity of other gases which it may already hold in solution.*

This absorption of gases may be determined by the *absorptiometer* represented in fig. 176, which consists of a graduated measuring tube, A, connected by an india-rubber tube with a tube of equal diameter, B. The absorption vessel, C, is connected with A by means of a thin flexible capillary lead tube; *a* and *b* are three-way stopcocks, and *c* an ordinary one. The vessel C is fitted with air-free liquid, and A with the gas, which by means of the two three-way stopcocks is easily effected. The tube B is raised or lowered until the level of the mercury is the same as in A, and the volume of gas is read off. A is now put in connection with C, and, the stopcock *c* having been opened, B is raised so that a determinate volume of liquid runs out. An equal volume of the gas then passes into C, and the absorption proceeds, C being constantly shaken. In order to work at constant temperature, A and C may be surrounded by water.

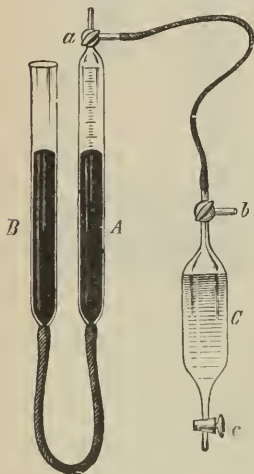

Fig. 176

In every gaseous mixture each gas exercises the same pressure as it would if its volume occupied the whole space; and the total pressure is

equal to the sum of the individual pressures. When a liquid is in contact with a gaseous mixture, it absorbs a certain part of each gas, but less than it would if the whole space were occupied solely by that gas. The quantity of each gas dissolved is proportional to the pressure which the unabsorbed gas exercises alone. For instance, oxygen forms only about $\frac{1}{5}$ the quantity of air; and water under ordinary conditions absorbs exactly the same quantity of oxygen as it would if the atmosphere were entirely formed of this gas under a pressure equal to $\frac{1}{5}$ that of the atmosphere.

191. **Diffusion of gases.**—Phenomena analogous to those of osmose (139) are seen in a high degree in the case of gases. When two different gases are separated by a porous diaphragm, an interchange takes place between them, and ultimately the composition of the gas on both sides of the diaphragm is the same; but the rapidity with which different gases *diffuse* into each other under these circumstances varies considerably. There is, however, an essential difference between the phenomena of osmose and those of diffusion; for while the inequality in the currents in the former case is due to the different attraction of the material of the diaphragm for the constituents, in the diffusion of gases the nature of this material has no influence;

from the smallness of the pores the actions are molecular, and not molar, and the rate of interchange depends only on the size of the molecules, that is, on the specific gravities of the gases. The laws of the diffusion of gases were investigated by Graham. Numerous experiments illustrate them, some of the most interesting of which are the following :—

A glass cylinder closed at one end is filled with carbonic acid gas, its open end tied over with a bladder, and the whole placed under a jar of hydrogen. Diffusion takes place between them through the porous diaphragm, and after the lapse of a certain time hydrogen has passed through the bladder into the cylindrical vessel in much greater quantity than the carbonic acid which has passed out, so that the bladder becomes very much distended outwards (fig. 177). If the cylinder is filled with hydrogen and the bell-jar with carbonic acid, the reverse phenomenon will be produced—the bladder will be pressed inwards (fig. 178).

A tube about 12 inches long, closed at one end by a plug of dry plaster of Paris, is filled with dry hydrogen, and its open end then immersed in a

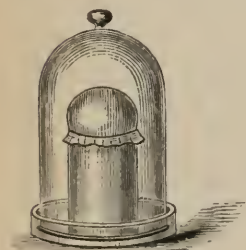

Fig. 177

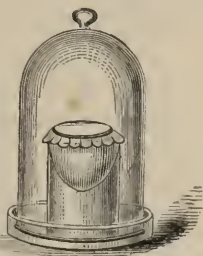

Fig. 178



Fig. 179

mercury bath. Diffusion of the hydrogen towards the air takes place so rapidly that a partial vacuum is produced, and mercury rises in the tube to a height of several inches (fig. 179). If several such tubes are filled with different gases, and allowed to diffuse into the air in a similar manner, in the same time, different quantities of the various gases will diffuse, and Graham found that the law regulating these diffusions is that *the quantity of a gas which passes through a porous diaphragm in a given time is inversely as the square root of the density of the gas*. Thus, if two vessels of equal capacity, containing oxygen and hydrogen, are separated by a porous plug, diffusion takes place; and after the lapse of some time, for every one part of oxygen which has passed into the hydrogen, four parts of hydrogen have passed into the oxygen. Now, the density of hydrogen being 1, that of oxygen is 16; hence the rapidity of diffusion is inversely as the square roots of these numbers. It is four times as great in the one which has $\frac{1}{16}$ the density of the other.

Let the stem of an ordinary tobacco pipe be cemented, so that its ends project, in an outer glass tube, which can be connected with an air-pump and thus exhausted. On allowing then a slow current of air to enter one

end of the pipe, its nitrogen diffuses more rapidly on its way through the porous pipe than the heavier oxygen, so that the gas which emerges at the other end of the porous pipe, and which can be collected, is richer in oxygen, and by repeating the operation on the gas which has passed through, the proportion of oxygen is so much increased that the gas can relight a

semi-extinguished taper. To this process, in which one gas can be separated from another by diffusion, the term *atmolysis* is given.

Fig. 180 is an excellent illustration of the action of diffusion. A porous pot, A, such as is used for voltaic cells, is fixed by means of a cork to the glass tube, which contains water up to the bulb, C, the upper part containing air. When a beaker containing hydrogen, B, is placed over the pot, the diffusion of the hydrogen into it is so rapid that the water is at once driven down and jets out. When the beaker is removed, the gas inside the pot, being richer in hydrogen, now diffuses out with great rapidity, and the water rises in the tube much higher than its original level.

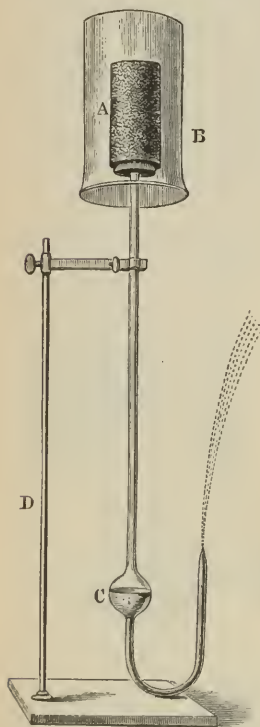

Fig. 180

192. **Effusion of gases.**—A gas can only flow from one space to another space occupied by the same gas when the pressure in the one is greater than in the other. *Effusion* is the term applied to the phenomenon of the passage of gases into vacuum, through a minute aperture not much more or less than 0.013 millimetre in diameter, in a thin plate of metal or of glass; for in a tube we are dealing with masses of gases, and friction comes into play, and in a larger aperture the particles would strike against one another, and form eddies and whirlpools. The velocity of the efflux is measured by the formula $v = \sqrt{2gh}$, in which h represents the

pressure under which the gas flows, expressed in terms of the height of a column of the gas which would exert the same pressure as that of the effluent gas. Thus for air under the ordinary pressure flowing into a vacuum the pressure is equivalent to a column of mercury 76 centimetres high; and as mercury is approximately 10,500 times as dense as air, the equivalent column of air will be $76 \times 10,500 \text{ cm.} = 7,980 \text{ metres.}$ Hence the velocity of efflux of air into vacuum is $= \sqrt{2 \times 9.8 \times 7980} = 395.5 \text{ metres per second.}$ This velocity into vacuum only holds, however, for the first moment, for the space contains a continually increasing quantity of air, so that the velocity becomes continually smaller, and is null when the pressure on each side is the same. If h and h' are the pressures of the gas on the two sides of the aperture, measured as before, the velocity of efflux at that moment is $v = \sqrt{2g(h-h')}$.

Since the height of a column of gas corresponding to a given pressure is inversely as the density of the gas, it follows that the *velocities of efflux of*

various gases must be inversely as the square roots of their densities. A simple inversion of this statement is that the densities of two gases are inversely as the squares of their velocities of effusion. On this law Bunsen has based an interesting method of determining the densities of gases and vapours, which is of great service where only small quantities of the substances are available.

The gas in question is contained (fig. 181) in a glass tube A, closed at the top with a stopper, S, in the neck, B. In a little enlargement here a thin platinum plate V is fixed, in which is a fine capillary aperture. The tube is depressed in a deep mercury trough, CC, until the top r of a glass float D is level with the mercury. The stopper S having been removed, the gas issues through the capillary aperture, and the time is noted which elapses until a mark t in the float is level with the mercury. Working in this way with different gases, Bunsen found that the ratios of the times of effusion are directly as the square roots of the densities, which is another form of the above statement.

By this method it may often be ascertained whether a gas is a mixture or not. Thus marsh gas (CH_4) has the same specific gravity (0.554) as a mixture in equal volumes of dimethyl (C_2H_6 , sp. gr. 1.039) and hydrogen (sp. gr. 0.069), and would furnish the same results on chemical analysis. But if the composition of the gas which had been subjected to effusion were examined in the two cases, it would be found that the residual marsh gas would retain the same composition, while that of the mixture would be different, for a relatively larger volume of the specifically lighter hydrogen would have passed out.

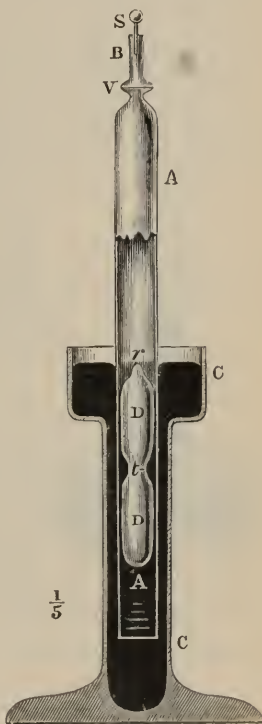

Fig. 181

193. **Transpiration of gases.**—If gases issue through long, fine capillary tubes into a vacuum, the phenomenon is called *transpiration*; and the rate of efflux, or the *velocity of transpiration*, is not the same as the rate of diffusion, either through a single aperture or through a series of fine capillary tubes, as in a porous diaphragm.

This property of gases may be investigated by means of an apparatus analogous to that represented in fig. 139, and consisting essentially of an arrangement by which gas under known pressure is allowed to flow through a capillary tube of known length and diameter.

The volume which flows out in a given time, or the rate of transpiration, is represented by a formula which is identical with Poiseuille's formula for liquids (146), namely,

$$v = \frac{\pi(p - p_1)r^4}{8\eta l}$$

where p is the pressure of the gas on entering, and p_1 that on leaving the capillary tube ; r is the diameter, and l the length of the tube, and η is the *coefficient of internal friction or viscosity of the gas*.

This method is a simple one for determining the value of η , as all the other magnitudes in this formula are capable of direct accurate measurement. This is a most important physical constant, as it occurs in many formulæ by which molecular magnitudes are determined, such as the length of the mean free path of the molecules of a gas (296), the number of impacts in a second, and even the dimensions of the molecules themselves. Expressed in C.G.S. units, the value of η for air is $0\cdot0318$.

194. **Absorption of gases by solids.**—The surfaces of all solid bodies exert an attraction on the molecules of gases with which they are in contact of such a nature that they become covered with a more or less thick layer of *condensed gas*. When a porous body, such as a piece of charcoal, which in consequence of its pores presents an immensely increased surface in proportion to its size, is placed in a vessel of ammonia gas over mercury (fig. 182), the great diminution of volume which ensues indicates that considerable quantities of gas are absorbed.

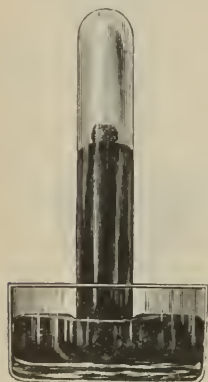

Fig. 182

Now, although there is no absorption such as arises from chemical combination between the solid and the gas (as with phosphorus and oxygen), still the quantity of gas absorbed is not entirely dependent on the physical conditions of the solid body ; it is influenced in some measure by the chemical nature both of the solid and the gas. Boxwood charcoal has very great absorptive power. The following table gives the volumes of gas, under standard conditions of tempera-

ture and pressure, absorbed by one volume of boxwood charcoal and of meerschaum respectively :—

	Charcoal	Meerschaum
Ammonia	90	15
Hydrochloric acid	85	—
Sulphurous acid	65	—
Sulphuretted hydrogen	55	11
Carbonic acid	35	5·3
Carbonic oxide	9·4	1·2
Oxygen	9·2	1·5
Nitrogen	7·4	1·6
Hydrogen	1·75	0·5

The absorption of gases is in general greatest in the case of those which are most easily liquefied.

Cocoa-nut charcoal is even more highly absorbent ; it absorbs 171 of ammonia, 73 of carbonic acid, and 108 of cyanogen at the ordinary pressure ; the amount of absorption increases with the pressure. The absorptive power of pine charcoal is about half as much as that of boxwood. The charcoal made from cork wood, which is very porous, is not absorbent ;

neither is graphite. Platinum, in the finely divided form known as *platinum sponge*, is said to absorb 250 times its volume of oxygen gas. Many other porous substances, such as gypsum, silk, &c., are also highly absorbent.

If a coin is laid on a plate of glass or metal, after some time, when the plate is breathed on, an image of the coin appears. If a figure is traced on a glass plate with the finger, nothing appears until the plate is breathed on, when the figure is at once seen. Indeed, the traces of an engraving which has long lain on a glass plate may be produced in this way.

These phenomena are known as *Moser's images*, for they were first investigated by Moser, although he explained them erroneously. The correct explanation was given by Waidele, who ascribed them to alterations in the layer of gas, vapour, and fine dust which is condensed on the surface of all solids. If this layer is removed by wiping, on afterwards breathing against the surface more vapour is condensed on the marks in question, which then present a different appearance from the rest.

If a die or a stamp is laid on a freshly polished metal plate, one therefore which has been deprived of its atmosphere, the layer of vapour from the coin will diffuse on to the metal plate, which thereby becomes altered; so that when this is breathed on an impression is seen.

Conversely, if a coin is polished and placed on an ordinary glass plate, it will partially remove the layer of gas from the parts in contact, so that on breathing on the plate the image is visible.

Ordinary glass kept in moist air becomes covered with a layer of water, which can be weighed. This is due to an action of the alkali in glass which attracts moisture, and is absent in glass free from alkali; it can be considerably diminished by boiling with water, by which the alkali on the surface is removed. In addition to this layer, which appears rather to be chemically than physically attracted, there is a temporary one which escapes in a vacuum at the ordinary temperature. These considerations will be seen to be of great importance when we come to consider the use of glass supports for electric apparatus.

195. **Occlusion of gases.**—Graham found that at a high temperature platinum and iron allow hydrogen to traverse them even more readily than does india rubber in the cold. Thus, while a square metre of india rubber 0.014 millimetre in thickness allowed 129 cubic centimetres of hydrogen at 20° to traverse it in a minute, a platinum tube 1.1 millimetre in thickness and of the same surface allowed 489 cubic centimetres to traverse it at a bright red heat.

This is probably connected with the property which some metals, though destitute of physical pores, possess of absorbing gases either on their surface or in their mass, and to which Graham has applied the term *occlusion*. It is best observed by allowing the heated metal to cool in contact with the gas. The gas which is then absorbed cannot be extracted by the air-pump, but is disengaged on heating. In this way Graham found that platinum occluded four times its volume of hydrogen; iron wire 0.44 its volume of hydrogen, and 4.15 volumes of carbonic oxide; silver, reduced from the oxide, absorbed about seven volumes of oxygen, and nearly one volume of hydrogen when heated to dull redness in these gases. This property is most remarkable in palladium, which absorbs hydrogen not only in cooling after being heated, but also in the cold. When, for instance, a

palladium electrode is used in the decomposition of water, one volume of the metal can absorb 980 times its volume of the gas. This gas is again driven out on being heated, in which respect there is a resemblance to the solution of gases in liquids. By the occlusion of hydrogen the volume of palladium is increased by 0.09827 of its original amount, from which it follows that the hydrogen, which under ordinary circumstances has a density of 0.000089546 that of water, has here a density nearly 9868 times as great, or about 0.88 that of water. Hence the hydrogen must be in the liquid or even solid state; it probably forms thus an alloy with palladium, like a true metal—a view of this gas which is strongly supported by independent chemical considerations. The physical properties, too, in so far as they have been examined, support this view of its being an alloy.

The phenomenon of occlusion may be illustrated by the following experiment (fig. 183). A platinum wire, *bc*, is stretched between supports on a

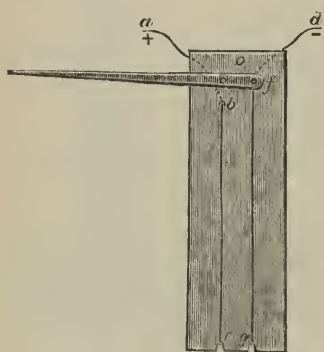

Fig. 183

glass plate; one end of a palladium wire, *fg*, is also fixed, the other end being attached to the short arm of a light lever movable about *o*, the long arm of which is loaded with a weight (not represented in the figure) to keep the wire tight. The platinum wire is connected with the positive pole *a*, and the palladium with the negative pole *d*, of a voltaic battery, and the apparatus is partially immersed in acidulated water; the water is thereby decomposed into its constituent gases; oxygen is liberated in bubbles from the platinum wire, but there is no visible disengagement at the palladium. The latter becomes longer, however, as is seen by the

motion of the lever. If the current is reversed, the wire again contracts, and the lever resumes its original position.

CHAPTER III

PRESSURE ON BODIES IN AIR. BALLOONS

196. Archimedes' principle applied to gases.—The pressure exerted by gases on bodies immersed in them is exerted equally in all directions, as has been shown by the experiment with the Magdeburg hemispheres (162). It therefore follows that all which has been said about the equilibrium of bodies in liquids applies to bodies in air; they lose apparently a part of their weight equal to that of the air which they displace.

The loss of weight in air is demonstrated by means of the *baroscope*, which consists of a scalebeam, at one end of which a small leaden weight is supported, and at the other there is a hollow copper sphere (fig. 184). In the air they exactly balance each other; but when they are placed under the receiver of an air-pump, and the air exhausted, the sphere sinks, thereby showing that in reality it is heavier than the smaller leaden

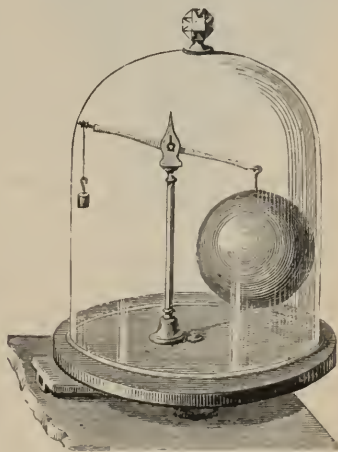

Fig. 184

weight. Before the air is exhausted each body is buoyed up by the weight of the air which it displaces. But as the sphere is much the larger of the two, its weight undergoes most apparent diminution, and thus, though in reality the heavier body, it is balanced by the small leaden weight. It may be proved by means of the same apparatus that this loss is equal to the weight of the displaced air. Suppose the volume of the sphere is 10 cubic inches. The weight of this volume of air is 3.1 grains. If now this weight be added to the leaden weight, it will overbalance the sphere in air, but will exactly balance it *in vacuo*.

The principle of Archimedes is true for bodies in air; all that has been said about bodies immersed in liquids applies to them; that is, that when a body is heavier than air it will sink, owing to the excess of its weight over the buoyancy. If it is as heavy as air, its weight will exactly counterbalance the buoyancy, and the body will float in the atmosphere. If the body is lighter than air, the buoyancy of the air will prevail and the body will rise

in the atmosphere until it reaches a layer of the same density as its own. The force causing ascent is equal to the excess of the buoyancy over the weight of the body. This is the reason why smoke, vapours, clouds, and air-balloons rise in the air. It will be understood that by *buoyancy* is meant the weight of the medium displaced whatever that medium may be.

AIR-BALLOONS

197. **Air-balloons.**—*Air-balloons* are hollow spheres made of some light impermeable material, which, when filled with heated air, with hydrogen gas, or with coal gas, rise in the air by virtue of their relative lightness.

They were invented by the brothers Montgolfier of Annonay, and the first experiment was made at that place in June 1783. Their balloon was a sphere of forty yards in circumference, and weighed 500 pounds. At the lower part there was an aperture, and a sort of boat was suspended, in which fire was lighted to heat the internal air. The balloon rose to a height of 2200 yards, and then descended without any accident.

Charles, a professor of physics in Paris, substituted hydrogen for hot air. He himself ascended in a balloon of this kind in December 1783. The use of hot-air balloons was entirely given up in consequence of the serious accidents to which they were liable.

Since then the art of ballooning has been greatly extended, and many ascents have been made. That which Gay-Lussac made in 1804 was the most remarkable for the facts with which it has enriched science, and for the height which he attained—23,000 feet above the sea-level. At this height the barometer sank to 12·6 inches, and the thermometer, which was 31° C. on the ground, was 9 degrees below zero.

In these high regions the dryness was such on the day of Gay-Lussac's ascent, that hygrometric substances, such as paper, parchment, &c., became dried and crumpled as if they had been placed near the fire. The respiration and circulation of the blood were accelerated in consequence of the great rarefaction of the air. Gay-Lussac's pulse made 120 pulsations in a minute instead of 66, the normal number. At this great height the sky had a very dark blue tint, and an absolute silence prevailed.

One of the most remarkable ascents was made by Mr. Glaisher and Mr. Coxwell, in a large balloon belonging to the latter. This was filled with 90,000 cubic feet of coal gas (sp. gr. 0·37 to 0·33); the weight of the load was 600 pounds. The ascent took place at 1 P.M. on September 5, 1861; at 1.28 they had reached a height of 15,750 feet, and in eleven minutes after a height of 21,000 feet, the temperature being $-10\cdot4^{\circ}$; at 1.50 they were at 26,200 feet, with the thermometer at $-15\cdot2^{\circ}$. At 1.52 the height attained was 29,000 feet, and the temperature -16° C. At this height the rarefaction of the air was so great, and the cold so intense, that Mr. Glaisher fainted and could no longer observe. According to an approximate estimation, the lowest barometric height they attained was 7 inches, which would correspond to an elevation of from 36,000 to 37,000 feet.

198. **Construction and management of balloons.**—A balloon (fig. 185) is made of long bands of silk sewed together and covered with india-rubber varnish, which renders it airtight. At the top there is a safety-valve closed

by a spring, which the aeronaut can open at pleasure by means of a cord. A light wickerwork car is suspended by means of cords to a network which entirely covers the balloon.

A balloon of the ordinary dimensions, which can carry three persons, is about 16 yards high, 12 yards in diameter, and its volume, when it is quite full, is about 680 cubic yards. The balloon itself weighs 200 pounds; the accessories, such as the rope and boat or car, 100 pounds.

The balloon is filled either with hydrogen or with coal gas. Although the latter is heavier than the former, it is generally preferred, because it is cheaper and more easily obtained. It is passed into the balloon from the gas reservoir by means of a flexible tube. It is important not to fill the balloon quite full, for the atmospheric pressure diminishes as it rises, and the gas inside, expanding in consequence of its elastic force, tends to burst it. It is sufficient for the ascent if the weight of the displaced air exceeds that of the balloon by 8 or 10 pounds. And this force remains constant so long as the balloon is not quite distended by the dilatation of the air in the interior. If the atmospheric pressure, for example, has diminished to one-half, the gas in the balloon, according to Boyle's law, has doubled its volume. The volume of the air displaced is therefore twice as great; but since its density has become only one-half, the weight, and consequently the upward buoyancy, are the same. When once the balloon is completely dilated, if it continues to rise, the force of the ascent decreases, for the volume of the displaced air remains the same, but its density diminishes, and a time arrives at which the buoyancy is equal to the weight of the balloon. The balloon can now only take a horizontal direction, carried by the currents of air which prevail in the atmosphere. The aeronaut knows by the barometer whether he is ascending or descending, and by the same means he determines the height which he has reached. A long flag fixed to the car would indicate, by the position it takes either above or below, whether the balloon is descending or ascending.

When the aeronaut wishes to descend, he opens the valve at the top of the balloon by means of the cord, which allows gas to escape, and the

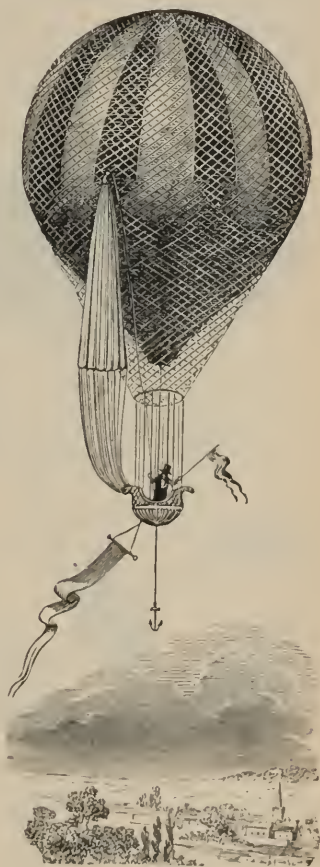

Fig. 185

balloon sinks. If he wants to descend more slowly, or to rise again, he empties out bags of sand, of which there is an ample supply in the car. The descent is facilitated by means of a grappling-iron fixed to the car. When once this is fixed to any obstacle, the balloon is lowered by pulling the cord.

199. **Parachute.**—The object of the parachute, seen on the left-hand side of the balloon in fig. 185 and shown extended in fig. 186, is to allow the aeronaut to leave the balloon, by giving him the means of lessening the rapidity of his descent. It consists of a large circular piece of cloth about 16 feet in diameter, which by the resistance of the air spreads out like a gigantic umbrella. In the centre there is an aperture through which the air

compressed by the rapidity of the descent makes its escape ; for otherwise oscillations might be produced which, when communicated to the car, would be dangerous.

The parachute is attached to the network of the balloon by means of a cord which passes round a pulley, and is fixed at the other end to the car. When the cord is cut the parachute sinks, at first very rapidly, but more slowly as it becomes distended.

The only practical applications which air-balloons have hitherto had have been in military reconnoitring. At the battle of Fleurus, in 1794, a captive balloon—that is, one held by a rope—was used, in which there was an observer who reported the movements of the enemy by means of signals. At the battle of Solferino the movements and dis-

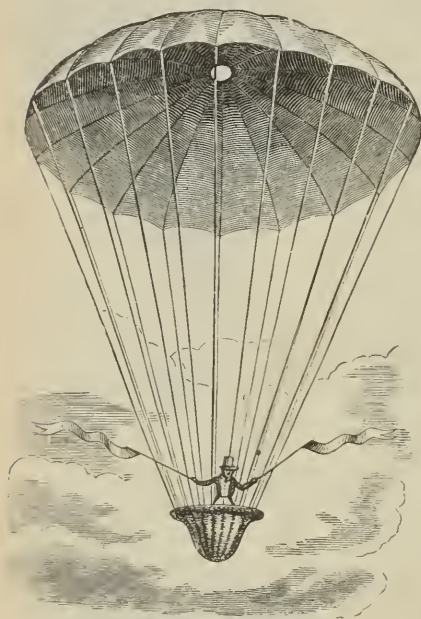

Fig. 186

positions of the Austrian troops were watched from a captive balloon ; and in the war in America balloons were frequently used, while their importance during the siege of Paris will not have been forgotten. In the war in South Africa frequent use was made of captive balloons. Air-balloons can only be truly useful when they can be guided, and as yet attempts made with this view have only partially succeeded. In 1902 M. Santos-Dumont constructed an air-ship in which, starting from the Parc d'Orient in Paris, he rounded the Eiffel Tower, and returned to the spot from which he started. The air-ship consisted of a balloon of cigar shape inflated with hydrogen, and containing an air bag for compensation. Below this was suspended a very light framework to which was attached the motor (a

petrol engine of 16 h.p.), the propeller, the rudder, and a wicker chair for the aeronaut. The total weight of the balloon and its appendages was 550 pounds.

200. **Calculation of the weight which a balloon can raise.**—To calculate the weight which can be raised by a balloon of given dimensions, let us suppose it perfectly spherical, and premise that the formulæ which express the volume and the superficies in terms of the radius are $V = \frac{4\pi R^3}{3}$, $S = 4\pi R^2$.

The radius R being measured in feet, let ρ be, in pounds, the weight of a square foot of the material of which the balloon is constructed; let P be the weight of the car and the accessories, a the weight in pounds of a cubic foot of air at zero, and under the pressure 76 cm., and a' the weight of the same volume, under the same conditions, of the gas with which the balloon is inflated (157). Then the total weight of the envelope in pounds will be

$4\pi R^2 \rho$; that of the gas will be $\frac{4\pi R^3 a'}{3}$; and that of the displaced air $\frac{4\pi R^3 a}{3}$.

If X is the weight which the balloon can support, we have

$$X = \frac{4\pi R^3 a}{3} - \frac{4\pi R^3 a'}{3} - 4\pi R^2 \rho - P.$$

Whence

$$X = \frac{4\pi R^3}{3} (a - a') - 4\pi R^2 \rho - P.$$

But, as we have before seen (198), the weight must be less by 8 or 10 pounds than that given by this equation, in order that the balloon may rise.

CHAPTER IV

APPARATUS WHICH DEPEND ON THE PROPERTIES OF AIR

201. **Air-pump.**—The air-pump is an instrument by which a vacuum can be produced in a given space, or rather by which air can be greatly rarefied, for an absolute vacuum cannot be produced by its means. It was invented

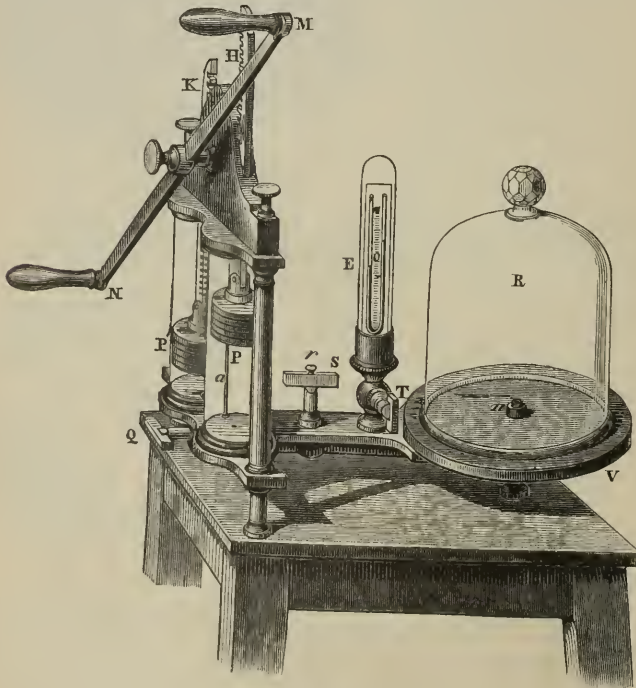

Fig. 187

by Otto von Guericke in 1650, a few years after the invention of the barometer.

The air-pump, as now usually constructed, may be described as follows. Fig. 187 represents a general view, fig. 188 a section, and figs. 189-194 various parts; the letters in all the figures having everywhere the same meaning.

The base VGL is of stout metal, and is firmly fixed on a table. At one end two glass cylinders or *barrels* are firmly cemented, and the two pistons P and P', tightly packed with leather washers, work airtight in them. To these pistons are attached racks H, K, and by means of a handle MN, working about a pinion X, the pistons P and P' are moved alternately up and down. On the plate V is fitted a thick glass plate with a very true surface. In its centre is a screw tubulure, *n*, fixed into a conduit *nc*, which connects the receiver and the barrels.

Fig. 189 gives a vertical section of one of the pistons on a larger scale. It consists of two brass discs, A and B, the latter of

which is provided with a brass tube in which is a screw, D; this presses together a number of leather washers very slightly larger than the disc. The leather is thoroughly soaked with oil, and slides airtight in the barrels, but with slight friction. D is pierced by a channel which connects it with the outer air. In the centre of the disc B is a hole, *z*, closed by a metal valve, Z, which is shod with cork, and by means of a rod, *e*, is kept in position in the channel.

A valve, *s*, opens and closes the orifice of the channel *c* which is in connection with the receiver. It is fixed to the end of a rod, *a*, which moves, but with friction, through the piston. Then when the piston sinks it carries with it the rod, *a*, and closes the orifice. As the piston rises it lifts the rod, but only for a small distance, for the rod strikes against the top of the barrel, and the piston, continuing its upward motion, slides along the rod.

The stopcock T connects the receiver R with the air-pump gauge E (202), while S connects the receiver with the barrels. When the receiver has been exhausted S is turned through a quarter, and the vacuum is thus preserved. Air can be admitted by opening a screw, *r*, at the top of a channel in the stopcock itself.

The piston P' being at the bottom of the barrel (fig. 190), as the handle is worked the piston rises, and with it the rod *a* and the valve *s*, while Z is closed by its own weight and the pressure of the air. A partial

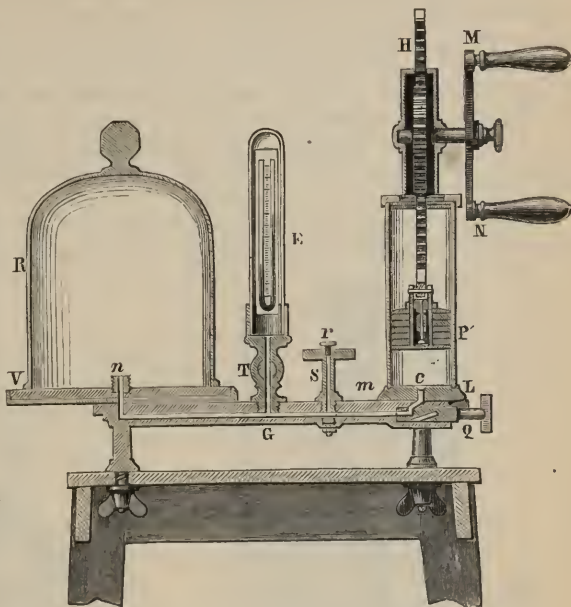

Fig. 188

vacuum is created under the piston, but the valve *s* having opened up connection with the receiver R, the air in this expands and fills both the receiver and the barrel. When P begins to descend, the valve *s* is closed by the descent of the rod *a*, the rarefied air in the barrel can no longer return to the receiver, it gets more and more condensed, and its pressure is ultimately great enough to open the valve Z, and the air under the piston escapes by the channel D into the outer air, and thus the rarefaction produced in the receiver is permanent. At the second stroke of the piston the same action is repeated, until a limit is reached at which, although there is air in the receiver, its elastic force is insufficient to raise the valve Z.

It is clear that when the rarefaction has proceeded to a considerable extent, the atmospheric pressure on the top of P will be very great, but it will

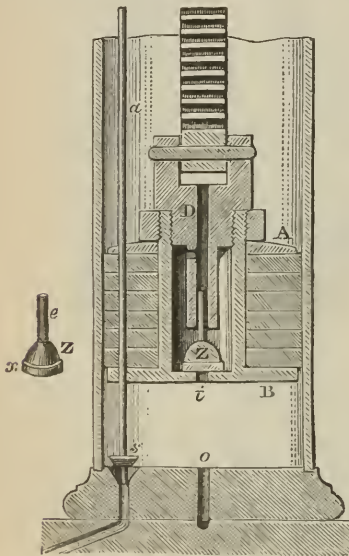

Fig. 189

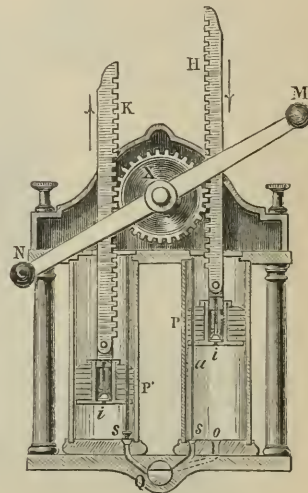

Fig. 190

be very nearly balanced by the atmospheric pressure on the top of the other piston. Consequently, the experimenter will have to overcome only the difference of the two pressures. This is the reason why two barrels are employed, a plan first adopted by Hawksbee.

202. **Air-pump gauge.**—When the pump has been worked some time the pressure in the receiver is indicated by the difference of level of the mercury in the two legs of a glass tube bent like a siphon, one of which is opened, and the other closed like a barometer. This little apparatus, which is called the *gauge*, is fixed to an upright scale and placed under a small bell-jar, E, which communicates with the receiver R by a stopcock, T, inserted in the tube leading from the orifice G to the cylinders (fig. 188).

Before the exhaustion begins, the pressure of the air in E exceeds the

weight of the column of mercury which is in the closed branch, and which consequently remains full. But as the pump is worked the pressure soon diminishes, and is unable to support the weight of the mercury, which sinks and tends to stand at the same level in both legs. If an absolute vacuum could be produced, they would be exactly on the same level, for there would be no pressure either on the one side or the other. But with the very best machines of this type the level is always about a thirtieth of an inch higher in the closed branch, which indicates that the pressure of the air in the receiver has been reduced to the $\frac{1}{30}$ part of an atmosphere.

Theoretically an absolute vacuum is impossible; for since the volume of each cylinder is, say, $\frac{1}{2}V$ that of the receiver, only $\frac{1}{2}$ of the air in the receiver is extracted at each stroke of the piston, and consequently it is impossible to exhaust all the air which it contains. The theoretical degree of exhaustion after a given number of strokes is easily calculated as follows:— Let a denote the volume of the receiver, including in that term the pipe; b the volume of the cylinder between the highest and lowest positions of the piston; and assume, for the sake of distinctness, that there is only one cylinder: then the air which occupied a before the piston is lifted occupies $a + b$ after it is lifted; and consequently if d_1 is the density at the end of the first stroke, and d the original density, we must have

$$d_1 = d \frac{a}{a + b}.$$

If d_2 is the density at the end of the second stroke, we have

$$d_2 = d_1 \frac{a}{a + b} = d \left(\frac{a}{a + b} \right)^2;$$

consequently, after n strokes, $d_n = d \left(\frac{a}{a + b} \right)^n$

If there are two equal cylinders, the same formula holds; but in this case, in counting n , upstrokes and downstrokes equally reckon as *one*.

If P_n is the pressure of the rarefied air after n strokes of the pump, and P the original (atmospheric) pressure, the above formula gives, since the pressure is directly proportional to the density when the volume and temperature are constant,

$$P_n = P \left(\frac{a}{a + b} \right)^n$$

It is obvious that the exhaustion is never complete, since d_n or P_n can be zero only when n is infinite. However, no very great number of strokes is required to render the exhaustion virtually complete, even if a is several times greater than b . Thus if $a = 10b$ a hundred strokes will reduce the density from d to $0.00007d$; that is, if the initial pressure is 30 inches, the pressure at the end of 100 strokes is 0.021 of an inch.

Practically, however, a limit is placed on the rarefaction that can be produced by any given air-pump; for, as we have seen, the air becomes ultimately so rarefied that, when the pistons are at the bottom of the cylinder, its elastic force cannot overcome the pressure in the valves on the inside of the piston; they therefore do not open, and there is no further action of the pump.

The space between the piston and the bottom of the barrel is called the *clearance*, and the efficiency of the pump depends upon this being made as small as possible.

203. **Double-exhaustion stopcock.**—By means of this device the exhaustion of the air can be carried to a very high degree. Fig. 190 gives a horizontal section of the stopcock Q, which by means of a central channel and two lateral ones forms a communication with the receiver and the barrels. When the working ceases, that is, when Z no longer rises, a quarter-turn is given to Q (fig. 192). The connections are now altered, as is seen from the horizontal sections in figs. 191 and 192, and the vertical sections in figs. 193 and 194. Figs. 191 and 193 refer to the state of things *before*, and figs. 192 and 194 *after* Q is turned. The new channels correspond now with

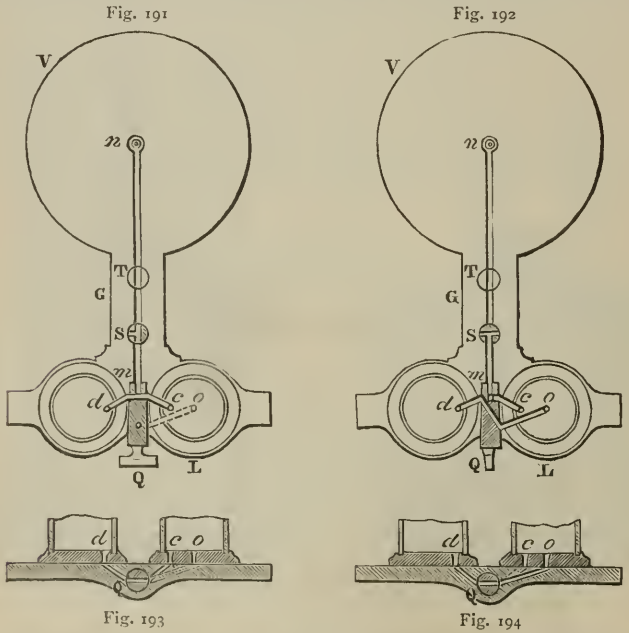

those of the base, and the right barrel is *alone* connected with the receiver by the channel *nmc*, while the left is connected by an oblique channel in the stopcock with a central aperture *o*, in the base of the right barrel.

The right piston as it rises exhausts air from the receiver; but when it sinks the exhausted air is drawn into the left barrel by the apertures *o* and *d*, this latter being always open, for the corresponding conical valve, *s*, is raised. When the right piston rises that of the left sinks; but the air below does not return to the right barrel, for the orifice is now closed by the conical valve. As the right cylinder continues to exhaust the air in the receiver, and to force it into the left cylinder, the air accumulates here, and ultimately acquires sufficient pressure to raise the valve of the piston *P'*, which was impossible before the stopcock was turned, for it is only when

the valves in the piston no longer open that a quarter of a turn is given to the stopcock. In this way a rarefaction of half a millimetre has been attained.

204. **Bianchi's air-pump.**—Bianchi invented an air-pump which has several advantages. It is made entirely of iron, and it has only one cylinder, which oscillates on a horizontal axis fixed at its base, as seen in fig. 195. A horizontal shaft, with heavy fly-wheel V, works in a frame, and is turned

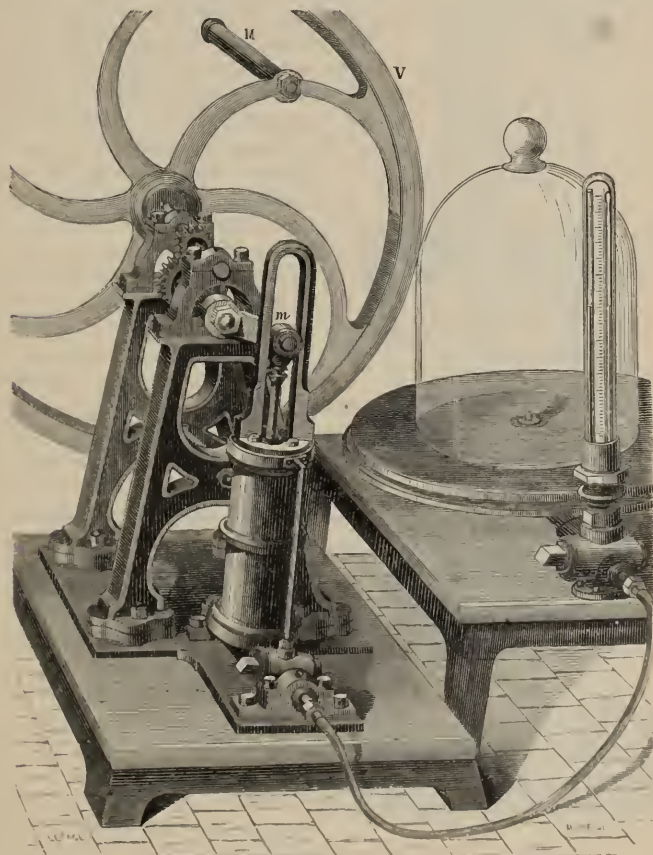

Fig. 195

by a handle, M. A crank, *m*, which is joined to the top of the piston rod, is fixed to the same shaft, and consequently at every revolution of the wheel the cylinder makes two oscillations.

In some cases, as in that shown in the figure, the crank and the fly-wheel are on parallel axes connected by a pair of cog-wheels. The modification in the action produced by this arrangement is as follows :—If the cog-wheel

on the former axis has twice as many teeth as that on the latter axis, the force which raises the piston is doubled: an advantage which is counter-balanced by the inconvenience that now the piston will make one oscillation for one revolution of the fly-wheel.

The machine is double-acting; that is, the piston PP (fig. 196) produces a vacuum, both in ascending and descending. This is effected by the following arrangements:—In the piston there is a valve, *b*, opening upwards as in the ordinary machine. The piston-rod AA is hollow, and in the inside there is a copper tube, X, by which the air escapes through the valve *b*. At the top of the cylinder there is a second valve, *a*, opening upwards. An iron rod, D, works with gentle friction in the piston, and terminates at its ends in two conical valves, *s* and *s'*, which fit into the openings of the tube B leading to the receiver.

Let us suppose the piston descends. The valve *s'* is then closed, and, the valve *s* being open, the air of the receiver passes into the space above the piston, while the air in the space below the piston undergoes compression, and, raising the valve, escapes by the tube X, which communicates with the atmosphere. When the piston ascends, the exhaustion takes place through *s'*, and the valve *s* being closed, the compressed air escapes by the valve *a*.

The machine has a stopcock for double exhaustion, similar to that already described (203). It is also oiled in an ingenious manner. A cup, E, round the rod is filled with oil, which passes into the annular space between the rod AA and the tube X; it passes then into a tube *oo* in the piston, and, forced by the atmospheric pressure, is uniformly distributed on the surface of the piston.

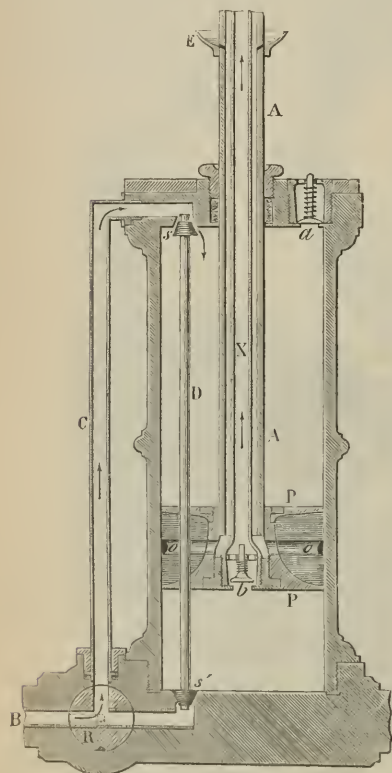

Fig. 196

The apparatus, being of iron, may be made of much greater dimensions than the ordinary air-pump. A vacuum can also be produced with it in far less time and in apparatus of greater size than usual.

205. **Fleuss or Geryk pump.**—The Fleuss pump is a mechanical pump by which a vacuum of 1 mm. of mercury can rapidly be obtained. A section of the pump is shown in fig. 197. AB is a cylinder in which a piston P, carried by a piston-rod C, moves up and down. Near the middle of the

cylinder is a partition with a central opening a , through which C passes, and J is a collar with a disc T attached, through which the piston-rod can slide airtight, and which serves as a valve. Due to the action of a strong spring, SS, the valve J keeps the aperture a ordinarily closed; but as the piston rises to the top of its stroke, its shoulder slightly raises J, and expels into the upper compartment any air which may have been carried up by the piston. EE is an annular space surrounding the lower compartment, communicating by G with the vessel to be exhausted, by H with the bottom of the cylinder, and by F with the lower compartment. D is a disc-valve in the piston closing an aperture, b , in the lower part of the piston, while c is an opening in the upper part. K is an opening communicating with the external air in the case of a single-barrel pump, and with the lower compartment of the second barrel, if the pump has two barrels, by a tube similar to G.

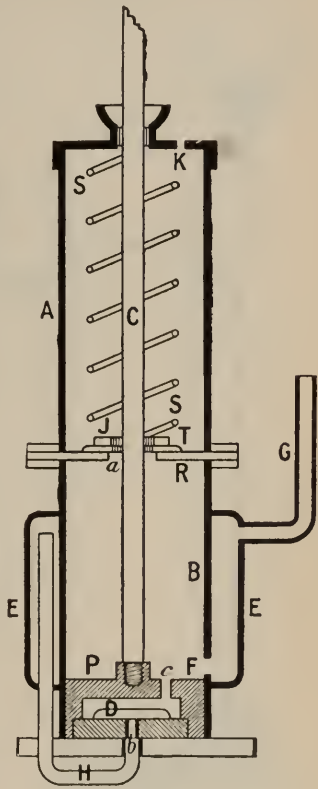

Fig. 197

The effective action of the pump depends upon a copious use of a special non-volatile oil which floods the lower parts of each compartment and seals all the joints and valves. It is a single-acting pump. In the position of the piston shown in the figure, the receiver communicates with B by the tube G. As the piston rises F is closed, the air in B is compressed, and escapes through the oil into the upper compartment in consequence of the valve J being slightly raised by the shoulder on the piston. When the piston descends the pressure of air below it raises the valve D, so that the pressures above and below the piston are equalised or nearly so. P has now reached the bottom, and the action is repeated. Thus at each double (down and up) stroke the volume of air contained in B is expelled. The merit of the pump consists in the absence of clearance at a ; all the air in B is expelled at each upstroke—its place being taken by oil.

206. **Sprengel's air-pump.**—Sprengel has devised a form of air-pump which depends on the principle of converting the space to be exhausted into a Torricellian vacuum.

If an aperture is made in the top of a barometer tube, the mercury sinks and draws in air; if the experiment is so arranged as to allow air to enter along with mercury, and if the supply of air is limited while that of mercury is unlimited, the air will be carried away and a vacuum produced. The following is the simplest form of the apparatus in which this action is realised. In fig. 198, cd is a glass tube longer than a barometer, open at both ends,

and connected by means of india-rubber tubing with a funnel, A, filled with mercury and supported by a stand. Mercury is allowed to fall in this tube at a rate regulated by a clamp at *c*; the lower end of the tube *cd* fits in the flask B, which has a spout at the side a little higher than the lower end of *cd*; the upper part has a branch at *x*, to which the vessel R to be exhausted can be tightly fixed. When the clamp at *c* is opened, the first portions of mercury which run out close the tube and prevent air from entering below. As the mercury is allowed to run down the exhaustion begins, and the whole length of the tube from *x* to *d* is filled with alternate cylinders of air and mercury moving downwards. Air and mercury escape through the spout of the flask B, which is above the basin H, where the mercury is collected. It is poured back from time to time into the funnel A, to be repassed through the tube until the exhaustion is complete. As this point is approached, the enclosed air between the mercury cylinders is seen to diminish, until the lower part of *cd* forms a continuous column of mercury about 30 inches high. Towards this stage of the process the falling mercury produces a noise like that of a water-hammer when shaken; the operation is completed when the column of mercury encloses no air, and a drop of mercury falls on the top of the column without enclosing the slightest air-bubble. The height of the column then represents the height of the column of mercury in the barometer;



Fig. 198

in other words, it is a barometer whose Torricellian vacuum is the receiver R. Modifications of this apparatus have been used with great success in experiments in which a very complete exhaustion is required, as in the preparation of Geissler's tubes and in incandescent electric lamps. It may be advantageously combined with a mechanical air-pump such as the Fleuss, which first removes the greater part of the air, the exhaustion being then completed as above.

The most perfect vacua are obtained by absorbing the residual gas, after the exhaustion has been pushed as far as possible, either mechanically or by some substance with which it combines chemically. Thus Dewar has produced a vacuum the pressure in which he estimates at $\frac{1}{330}$ of a millimetre, by heating charcoal to redness, in a vessel from which air had been

exhausted by the Sprengel pump, and then allowing it to cool. Finkener filled a vessel with oxygen, then exhausted as far as possible, and finally heated to redness some copper contained in the vessel. This absorbed the minute quantity of gas left, with the formation of copper oxide. In some of his experiments Crookes obtained by chemical means a vacuum of $\frac{1}{250000}$ of a millimetre. This represents a pressure of one-twentieth of a millionth of an atmosphere (micro-atmosphere). In these highly rarefied gases the pressure is so low that it is very difficult to measure minute differences.

For such cases McLeod has devised a very valuable gauge, the principle of which is to condense a measured volume of the highly rarefied gas to a much smaller volume, and then to measure its pressure under the new conditions. McLeod's gauge is illustrated in fig. 199. BG is a vertical tube connected above with the vessel which is being exhausted, and dipping into a bottle, F, containing mercury. The latter is connected by a tube, E, with a Bunsen's pump (207), so that the pressure in the space above the mercury in F can be reduced. ACK is a tube the upper part of which, AC, is capillary and graduated, the volume of the whole tube and of the capillary part for each division being carefully determined. This tube fits airtight into the opening of a lateral projection, D, from the tube BG, the junction being sealed by mercury in the cup L. The upper part of BG is of the same tubing as AC, to avoid errors from capillarity, and is also graduated.

To determine the pressure of the rarefied air, we proceed as follows:—Turn the stopcock E and admit air into F: the mercury at G rises, reaches K, and shuts off in ACD a known volume V of air at a pressure P (mm.) which is to be determined. The mercury still rising compresses this air, and reaches a point A, while in the long tube it stands (say) at B, h mm. above A. The volume v above A is known; the pressure on the mercury at B is P , for it has not been sensibly altered by rise of the mercury from G to B. Hence by Boyle's law $VP = v(P + h)$, whence P is determined. Care must be taken to maintain the temperature constant.

207. **Bunsen's Sprengel pump.**—This is a convenient arrangement for producing a very considerable exhaustion in cases where a good supply of water is available, as in laboratories. A composition tube, a (fig. 200), connected with the service-pipe of a water-supply, is joined by means of an india-rubber tube to a glass tube, cdf , to which is attached at f a leaden tube about 10 to 12 yards long. The tube sr is connected with the space to be exhausted.

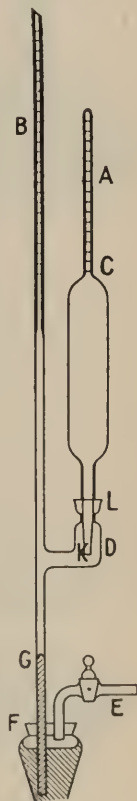

Fig. 199

The water enters by *a* and in falling down the tube carries with it air from the space to be exhausted. The supply of water, and therewith the

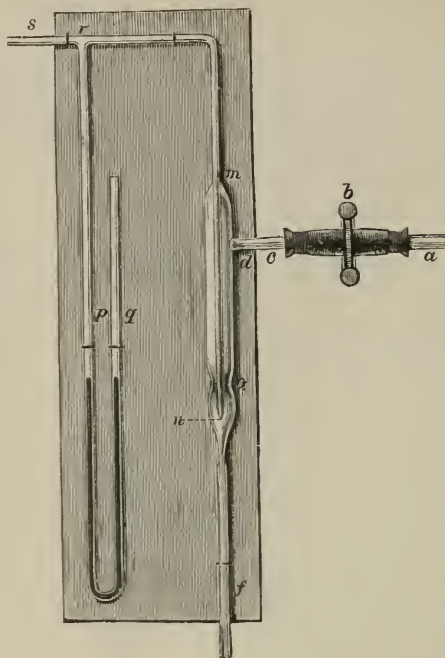

Fig. 200

rate of exhaustion, can be regulated by the stopcock *b*; the bent tube *pq*, which contains mercury, measures the pressure which may be reduced to 10 to 15 millimetres.

208. **Aspirating action of currents of air.**—When a jet of liquid or of a gas passes through air, it carries the surrounding air along with it, fresh air rushes in to supply its place, comes also in contact with the jet, and is in like manner carried away. Thus, then, there is a continual rarefaction of the air round the jet, in consequence of which it exerts an aspiratory action.

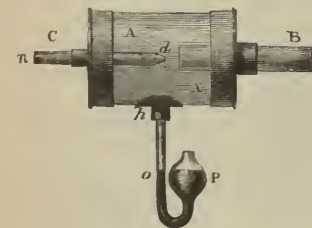

Fig. 201

This phenomenon may be well illustrated by means of an apparatus represented in fig. 201, the analogy of which to the experiment described (145) will be at once evident. It consists of a wide glass

tube, in the two ends of which are fitted two small tubes, *nd* and *B*; in the bottom is a manometer tube containing a coloured liquid. On blowing through the narrow tube the liquid at *o* is seen to rise. If on the contrary the wide tube is blown into, a depression is produced at *o*.

To this class of phenomena belongs the following experiment, which is a simple modification of one originally described by Clément and Désormes. A tube is fixed in a metal disc (fig. 202), its end being flush with the surface. A light disc is held at a little distance by means of three metal studs. Holding the tube vertically with the discs downwards, and blowing into it, the movable disc is seen to rise until it comes in contact with the upper one. The current of air spreads out from the centre of the plate towards the circumference, and in doing so is rarefied; in consequence of this lessened pressure in the space, the lower disc is lifted by the external pressure against the upper one, where it remains as long as the blowing continues. The simplest plan of making this experiment was devised by Faraday. Holding one hand horizontal, the palm downwards and the fingers closed, the space between the index and middle fingers is blown through. If a piece of light paper, of 2 or 3 square inches, is held against the aperture, it does not fall as long as the blowing continues.

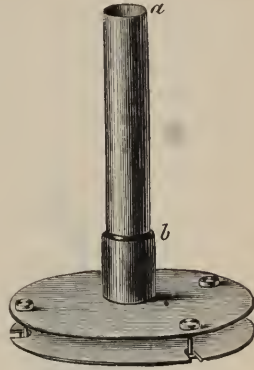

Fig. 202

The old *water-bellows*, still used in mountainous places where there is a continuous fall, is a further application of the principle. Water falling from a reservoir down a narrow tube divides and carries air along with it; and, if there are apertures in the sides through which air can enter, this also is carried along, and becomes accumulated in a reservoir placed below, from which by means of a lateral tube it can be directed into the hearth of a forge.

This may be illustrated by the simple apparatus represented in fig. 203, the construction of which from glass tubes and corks will be readily intelligible. It may be remarked

that the outer tube is at *b* represented in section, and that the parts of the tubes *of d*

and *h* outside the cork are relatively much longer horizontally and vertically than is here represented.

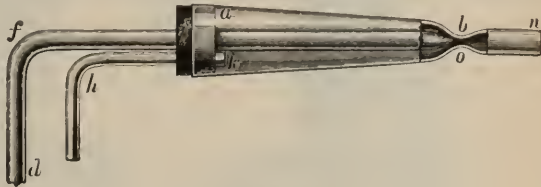

Fig. 203

If the vertical tube *fd* is fitted to a vessel of boiling water, as soon as steam issues through *o*, it not only raises water from a vessel in which the bottom of the tube *h* dips, but drives it through the aperture *o*. And if a bent tube, with a narrow opening like *o*, is fitted at *n*, and directed upwards, a continuous jet of water is produced, often reaching to the ceiling.

This apparatus serves well to illustrate the principle of *Giffard's injector*, an extremely ingenious and important apparatus by which steam-boilers are kept supplied with water.

The principle is also applied in a series of machines for moving and

lifting liquids, and even solids such as corn; in pumping, in blowers, exhausters, air-pumps, &c. An interesting application is that of the well-known *spray producer*; this principle has further been utilised by Sprengel in supplying water to sulphuric acid chambers.

By the *locomotive steam-pipe* a jet of steam entering the chimney of the locomotive carries the air away, so that fresh air must arrive through the fire, and thus the draught is kept up.

209. **Morren's mercury pump.**—Figs. 204 and 205 represent a mercury air-pump, constructed by Alvergriat. It consists of two reservoirs, A

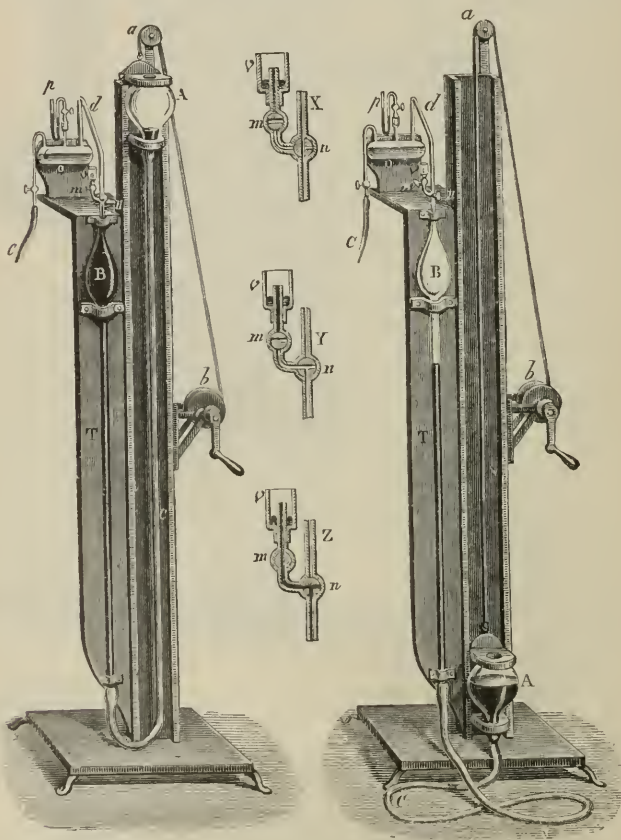

Fig. 204

Fig. 205

and B, connected by a barometer tube, T, and a long india-rubber tube, C. The reservoir B and the tube T are fixed to a vertical support; A, which is movable and open, can be alternately raised and lowered through a distance of nearly 4 feet. This is effected by means of a long wire rope, which is fixed at one end to the reservoir A, and passes over two pulleys, *a* and *b*, the latter of which is turned by a handle. Above the reservoir B is a three-

way cock, *n*; to this is attached a tube, *a*, for exhaustion, and on the left is an ordinary stopcock, *m*, which communicates with a reservoir of mercury, *v*, and with the air. The exhausting tube *d* is not in direct communication with the receiver to be exhausted; it is first connected with a reservoir, *o*, partially filled with sulphuric acid, and designed to dry the gases which enter the apparatus. An india-rubber tube, *c*, makes communication with the receiver which is to be exhausted. On the reservoir *o* is a small mercury manometer, *p*.

These details being understood, suppose the reservoir A at the top of its course (fig. 204), the stopcock *m* open, and the stopcock *n* turned as seen in Z; the india-rubber tube C, the tube T, the reservoir B, and the tube above are filled with mercury as far as *v*; closing then the stopcock *m*, and lowering the reservoir A (fig. 205), the mercury sinks in the reservoir B and in the tube T, until the difference of levels in the two tubes is equal to the barometric height, and there is a vacuum in the reservoir B. Turning now the stopcock *n* as shown in fig. X, the gas from the space to be exhausted passes into the barometer chamber B by the tubes *c* and *d*, and the level again sinks in the tube T. The stopcocks are now replaced in the first position (fig. Z), and the reservoir A is again lifted, the excess of pressure of mercury in the india-rubber tube expels, through the stopcocks *n* and *m*, the gas which had passed into the chamber B, and, if a few droplets of mercury are carried along with it, they are collected in the vessel *v*. The process is repeated until the mercury is virtually at the same level in both legs of the gauge.

Like Sprengel's pump, this is very slow in its working, and, like it, is best employed in completing the exhaustion of a space which has already been partially rarefied; for a vacuum of $\frac{1}{10}$ of a millimetre may be obtained by its means.

210. **Condensing pump.**—The condensing pump is an apparatus for compressing air or any other gas. The form usually adopted is the following:—In a cylinder, A, of small diameter (fig. 207), there is a solid piston, the rod of which is moved by the hand. The cylinder is provided with a screw which fits into the receiver K. Fig. 206 shows the arrangement of the valves, which are so constructed that the lateral valve *o* opens into the cylinder A, and the lower valve *s* downwards towards the receiver.

When the piston descends the valve *o* closes, and the air in the cylinder A is forced through the valve *s* into the receiver. When the piston ascends, *s* closes and *o* opens, and permits the entrance of fresh air, which in turn

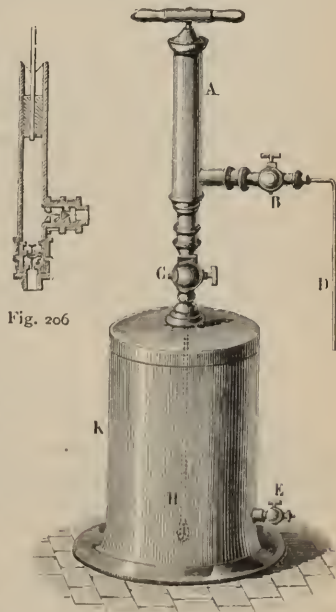

Fig. 207

becomes compressed by the descent of the piston, and so on. This apparatus is useful for charging liquids with gases. For this purpose the stopcock B is connected with a reservoir of the gas by means of the tube D. The pump exhausts this gas, and forces it into the vessel K, in which the liquid is contained. Artificial gaseous waters are made by means of analogous apparatus.

Suppose air is being compressed into K. If a and b denote the volumes of the receiver and cylinder respectively, P atmospheric pressure, and $P_1, P_2, \dots P_n$ the pressures of the compressed air after 1, 2, \dots n strokes of the piston, we see that after one downward stroke the volume $a + b$ at pressure P is compressed into a at pressure P_1 ; $\therefore P(a + b) = P_1 a$. As the piston rises the cylinder is refilled with air at atmospheric pressure. At the end of the second stroke, $P(a + 2b) = P_2 a$; and after n strokes, $P(a + nb) = P_n a$, assuming constancy of temperature.

The applications of condensed air are both numerous and important. In a certain sense condensed air plays the part of a metal spring in which energy is stored, and from which it can be drawn and utilised by expanding the air at a given moment and at a given point in the most favourable condition for its being applied. In some cases the expansion is sudden and intermittent, as in the air-gun, the pneumatic post, or in atmospheric brakes; and in some cases slow, gradual, and continuous, as in boring machines.

One of the most important applications is that to the larger boring machines used in tunnelling through the Alps and elsewhere. There, where steam power would be objectionable owing to the steam produced, compressed air is of great service, for it not only supplies the power, but it helps to ventilate the underground spaces.

The principal parts of such machines, which were first employed on a large scale in the Mont Cenis tunnel, are as follows:—A sheaf of borers or iron rods with punches on the ends are mounted on a framework. Each of these borers is susceptible of three simultaneous motions: one backward and forward producing repeated shocks against the rock; a second analogous to that of a gimlet; while a third moves the whole framework backwards and forwards.

This triple motion is effected by a machine like a steam-engine, but driven by compressed air; the first motion by a piston, the action of which is regulated by a slide valve (476); the other two motions are effected by means of a separate machine. The air is under a pressure of five atmospheres, the compression being effected by special machines worked by water-power. The air, by which all this is effected, on expanding helps to cool and ventilate the mine.

The *pneumatic post* is of great service in London and other large towns in forwarding the actual written telegraphic messages from the several receiving stations to a central telegraph station. The messages are placed in a *carrier*, which is a gutta-percha cylinder 7 inches long by 2 inches in diameter, closed at one end; it is covered with felt, and there is a welt of that material at one end; the felt projects at the other, so that it can be folded down and held in position by an india-rubber band, so as to keep the contents in their place.

Such carriers move airtight in carefully turned leaden tubes polished internally and protected by being incased in iron tubes. The propulsion is effected either by pressure or by exhaustion; and by suitable valves the tubes can be placed in connection with compressed or rarefied air, so that the carriers may either be shot in one direction by compressed air, or drawn in the other by rarefied air. The compression and rarefaction are produced by means of powerful steam-engines to a pressure of about 10 pounds, or a vacuum of 8 pounds to the square inch. By this means a speed of nearly a mile in a minute may be obtained in tubes not more than a mile in length.

Other applications of compressed air are in the small pumps used by plumbers for testing and for clearing gas-pipes, in ventilating mines, in supplying air to blast furnaces, in the atmospheric brakes used in railway trains, as motive power in torpedoes, and so forth.

Compressed air has long been used in Paris for the synchronised working of clocks, and this has led to its successful application on a large scale for the transmission of power from a central station for working small motors. It is distributed in tubes a foot in diameter under a pressure of 6 atmospheres, and in this way it is possible to work small air motors at a distance of four miles from the source of power with an efficiency of 50 per cent.

211. **Uses of the air-pump.**—A great many experiments with the air-pump have been already described. Such are the mercurial rain (13), the fall of bodies *in vacuo* (78), the bladder (155), the bursting of a bladder (161), the Magdeburg hemispheres (162), and the baroscope (196).

The fountain *in vacuo* (fig. 208) is an experiment made with the air-pump, and shows the elastic force of the air. It consists of a glass vessel, A, provided at the bottom with a stopcock and a tubulure which projects into the interior. This apparatus having been screwed to the air-pump is exhausted, and the stopcock being closed, is placed in a vessel of water, R. When the stopcock is opened, atmospheric pressure acting upon the water in the vessel forces the water through the tube in a jet, as shown in the drawing.

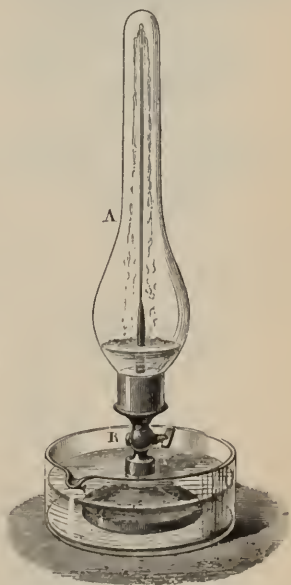

Fig. 208

Fig. 209 represents an experiment illustrating the effect of atmospheric pressure on the human body. A glass vessel, open at both ends, being placed on the plate of the machine, the upper end of the cylinder is closed by the hand, and the pump set in action. The hand is then forced down by the difference between the pressure outside and inside, and can only be taken away by a great effort. And as the elasticity of the fluids contained in the blood-vessels and

other organs is not counterbalanced by the pressure of the atmosphere, the palm of the hand swells, and blood tends to escape from the pores.

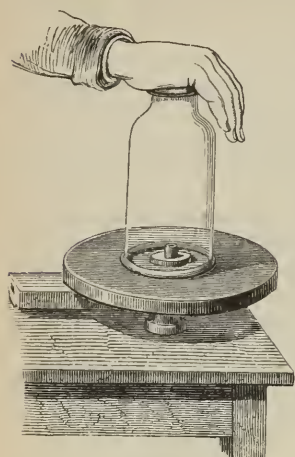

Fig. 209

By means of the air-pump it may be shown that air, by reason of the oxygen it contains, is necessary for the support of combustion and of life. For if we place a lighted taper under the receiver, and begin to exhaust the air, the flame becomes weaker as rarefaction proceeds and is finally extinguished. Similarly, an animal faints and dies if a vacuum is formed in a receiver under which it is placed. Mammalia and birds soon die *in vacuo*. Fish and reptiles support the loss of air for a much longer time. Insects can live several days *in vacuo*.

Substances liable to ferment may be kept *in vacuo* for a long time without alteration, as they are not in contact with oxygen, which is necessary for fermentation. Food kept in airtight cases, from which the air had been exhausted, has been found as fresh after years as on the first day.

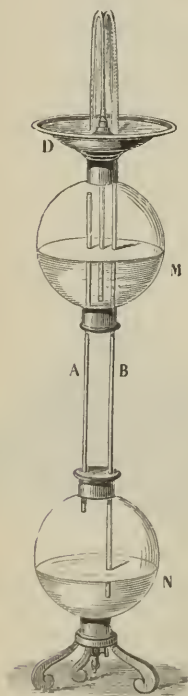

Fig. 210

212. **Hero's fountain.**—Hero's fountain, which derives its name from its inventor, Hero, who lived at Alexandria, 120 B.C., depends on the elasticity of the air. It consists of a brass dish, D (fig. 210), and of two glass globes, M and N. The dish communicates with the lower part of the globe N by a long tube, B; and another tube, A, connects the two globes. A third tube passes through the dish D to the lower part of the globe M. This tube having been taken out, the globe M is partially filled with water; the tube is then replaced and water is poured into the dish. The water flows through the tube B into the lower globe, and expels the air, which is forced into the upper globe; the air, thus compressed, acts upon the water, and makes it jet out as represented in the figure. If it were not for the resistance of the atmosphere and friction, the liquid would rise to a height above the water in the dish equal to the difference of the level in the two globes.

213. **Intermittent fountain.**—The *intermittent fountain* consists of a stoppered glass globe (C, fig. 211), provided with two or three lateral tubes with fine nozzles, D.

A glass tube open at both ends reaches at one end to the upper part of the globe C; the other end terminates just above a little aperture in the dish B, which supports the whole apparatus.

The water with which the globe C is nearly two-thirds filled runs out by the tubes D, as shown in the figure, the internal pressure at D being equal to the atmospheric pressure together with the weight of the column of water CD, while the external pressure at that point is only that of the atmosphere. These conditions prevail so long as the lower end of the glass tube is open, that is, so long as air can enter C and keep the air in C at the same density as the external air; but the apparatus is arranged so that the orifice in the dish B does not allow so much water to flow out as it receives from the tubes D, in consequence of which the level gradually rises in the dish, and closes the lower end of the glass tube. As the external air cannot now enter the globe C, the air becomes rarefied in proportion as the flow continues, until the pressure of the column of water CD, together with that of the air contained in the globe, is equal to this external pressure at D; the flow consequently stops. But as water continues to flow out of the dish B, the tubes D become open again, air enters, and the flow recommences, and so on, as long as there is water in the globe C.

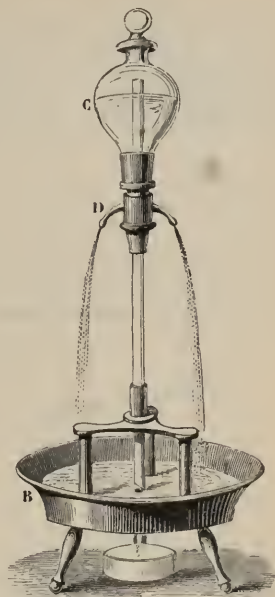

Fig. 211

214. **The siphon.**—The siphon is a bent tube open at both ends, and with unequal legs (fig. 212). It is used in transferring liquids in the following manner:—The siphon is filled with some liquid, and, the two ends being closed, the shorter leg is dipped in the liquid, as represented in fig. 212; or, the shorter leg having been dipped in the liquid, the air is exhausted by applying the mouth at B. The air in the tube is thus rarefied, and the liquid in C rises and fills the tube in consequence of the atmospheric pressure. It will then run out through the siphon as long as the shorter end dips in the liquid.

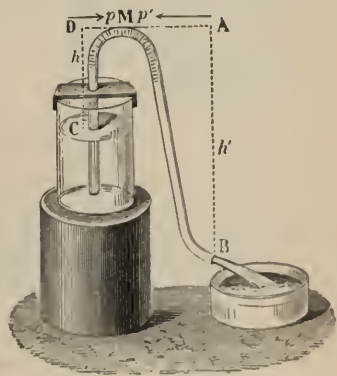

Fig. 212

To explain this flow of water from the siphon, let us suppose the siphon filled and the short leg immersed in the liquid; also suppose B temporarily

closed. Then, considering the pressure at the point M in the tube in so far as it is influenced by the liquid in the tube MC, we see that this pressure is equal to the atmospheric pressure minus the pressure due to DC, or $H - h$, if H represents the height of the water barometer. This, if it acted alone, would cause the liquid at M to move in the direction DA. But the pressure at M, considered as influenced by the liquid in the tube MB, is equal to atmospheric pressure minus the pressure due to the column AB or $H - h'$, and this acts from A to D. Now $H - h > H - h'$, if $h' > h$. Thus water will flow from the vessel if AB is greater than DC. If $AB = DC$, there will be no flow; and if AB is less than DC, the liquid will flow in the opposite direction.

It follows from the explanation of the siphon that it would not work *in vacuo*, nor if the height CD were greater than that of a column of liquid which counterbalances the atmospheric pressure.

215. **The intermittent siphon.**—In the *intermittent* siphon the flow is not continuous. It is arranged in a vessel, so that the shorter leg is near the



Fig. 213

bottom of the vessel, while the longer leg passes through it (fig. 213). Being fed by a constant supply of water, the level gradually rises both in the vessel and in the tube to the top of the siphon, which it fills, and water begins to flow out. But the apparatus is arranged so that the flow of the siphon is more rapid than that of the tube which supplies the vessel, and consequently the level sinks in the vessel until the shorter branch no longer dips in the liquid; the siphon is then empty, and the flow ceases. But as the vessel is continually fed from the same source

the level again rises, and the same series of phenomena is reproduced.

The theory of the intermittent siphon explains the natural intermittent springs which are found in many countries, and of which there is an excellent example near Giggleswick in Yorkshire. Many of these springs furnish water for several days or months, and then, after stopping for a certain interval, again recommence. In others the flow stops and recommences several times in an hour.

These phenomena are explained by assuming that there are subterranean fountains, which are more or less slowly filled by springs, and which are then emptied by fissures so occurring in the ground as to form an intermittent siphon.

216. **Different kinds of pumps.**—*Pumps* are machines which serve to raise water either by suction, by pressure, or by both effects combined; they are consequently divided into *suction or lift pumps*, *force-pumps*, and *suction and forcing pumps*.

The various parts entering into the construction of a pump are the barrel, the piston, the valves, and the pipes. The *barrel* is a cylinder of metal or of wood, in which is the *piston*. The latter is a metal or wooden cylinder wrapped with tow, and working with gentle friction the whole length of the barrel.

The valves are discs of metal or leather, which alternately close the

apertures which connect the barrel with the pipes. The most usual valves are the *clack valve* (fig. 214) and the *conical valve* (fig. 215). The former is a metal disc fixed to a hinge on the edge of the orifice to be closed. In order more effectually to close it, the lower part of the disc is covered with thick leather. Sometimes the valve consists merely of a leather disc, of larger diameter than the orifice, nailed on the edge of the orifice. Its flexibility enables it to act as a hinge.



Fig. 214

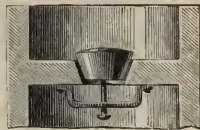

Fig. 215

The conical valve consists of a metal cone fitting in an aperture of the same shape. Below this is an iron hoop, through which passes a bolt-head fixed to the valve. The object of this is to limit the play of the valve when it is raised by the water, and to prevent its removal.

217. **Suction-pump.**—Fig. 216 represents a model of a suction-pump such as is used in lectures, but which has essentially the same arrangement as the pumps in common use. It consists, 1st, of a *glass cylinder*, B, at the bottom of which is a valve, S, opening upwards; 2nd, of a *suction-tube*, A, which dips into the reservoir from which water is to be raised; 3rd, of a *piston*, which is moved up and down by a rod worked by a handle, P. The piston is perforated by a hole; the upper aperture is closed by a valve O, opening upwards.

When the piston rises from the bottom of the cylinder B, a vacuum is produced below, and the valve O is kept closed by the atmospheric pressure, while the air in the pipe A, in consequence of its elasticity, raises the valve S, and partially passes into the cylinder. The air being thus rarefied, water rises in the pipe until the pressure of the liquid column, together with the pressure of the rarefied air which remains in the tube, counterbalances the pressure of the atmosphere on the water of the reservoir.

When the piston descends, the valve S closes by its own weight, and prevents the return of the air from the cylinder into the tube A. The air compressed by the piston opens the valve O, and escapes into the atmosphere by the pipe C. With a second stroke of the piston the same series of phenomena

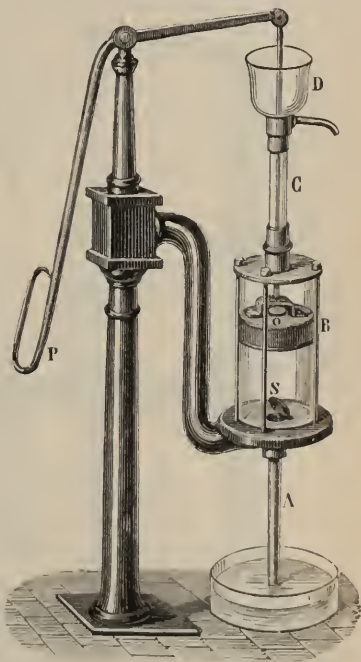

Fig. 216

is produced, and after a few strokes the water reaches the cylinder. The effect is now somewhat modified ; during the descent of the piston the valve S closes, and the water raises the valve O, and passes above the piston by which it is lifted into the upper reservoir D. There is now no more air in the pump, and the water forced by the atmospheric pressure rises with the piston. It is essential for the action of the pump that the valve S should be less than 34 feet above the level of the water in which the tube A dips, for we have seen (163) that a column of water of this height is equal to the pressure of the atmosphere.

In practice the height of the tube A does not exceed 26 to 28 feet; for although the atmospheric pressure can support a higher column, the vacuum produced in the barrel is not perfect, owing to the fact that the piston does not fit exactly on the bottom of the barrel. But when the water has passed the piston, it is the force applied to the latter which raises it, and the height to which it can be brought depends on the power which works the piston.

218. Suction- and force- pump.—The action of this pump, a model of

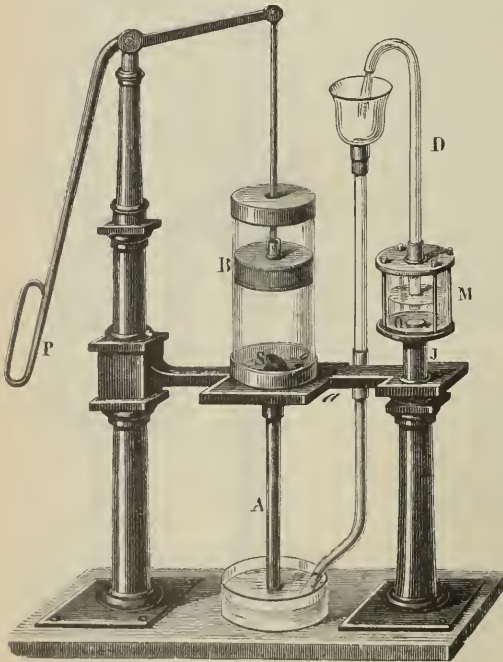

Fig. 217

which is represented in fig. 217, depends both on exhaustion and on pressure. At the base of the barrel, where it is connected with the tube A, there is a valve, S, which opens upwards. Another valve, O, opening in the same direction, closes the aperture of a conduit, which passes from a hole, *o*, near the valve S, into a vessel, M, which is called the *air-chamber*. From this chamber there is another tube, D, up which the water is forced.

At each ascent of the piston B, which is solid, the water rises through the tube A into the barrel. When the piston sinks the valve S closes, and the water is forced through the valve O into the reservoir M, and thence into the tube D. The height

to which it can be raised in this tube depends solely on the motive force which works the pump.

If the tube D were a prolongation of the tube *Ja*, the flow would be intermittent ; it would take place when the piston descended, and would

cease as soon as it ascended. But between these tubes there is an interval, which, by means of the air in the reservoir M, ensures a continuous flow. The water forced into the reservoir M divides into two parts, one of which, rising in D, presses on the water in the reservoir by its weight; while the other, in virtue of this pressure, rises in the reservoir above the lower orifice of the tube D, compressing the air above. Consequently, when the piston ascends, and no longer forces the water into M, the air of the reservoir expands, and raises the liquid in the tube D, until the piston again descends, so that the jet is continuous.

219. **Load which the piston supports.**—In the suction-pump, when once the water fills the pipe, and the barrel, as far as the spout, *the effort necessary to raise the piston is equal to the weight of a column of water the base of which is this piston, and the height the vertical distance in the spout from the level of the water in the reservoir; that is, the height to which the water is raised.* For if H is the atmospheric pressure, h the height of the water above the piston, and h' the height of the column which fills the suction-tube A (fig. 217), and the lower part of the barrel, the pressure above the piston is obviously $H + h$, and that below is $H - h'$, since the weight of the column h' tends to counterbalance the atmospheric pressure. But as the pressure $H - h'$ tends to raise the piston, the effective resistance is equal to the excess of $H + h$ over $H - h'$; that is to say, to $h + h'$.

In the suction- and force- pump it is readily seen that the pressure which the piston supports is also equal to the weight of a column of water the base of which is the section of the piston, and the height that to which the water is raised.

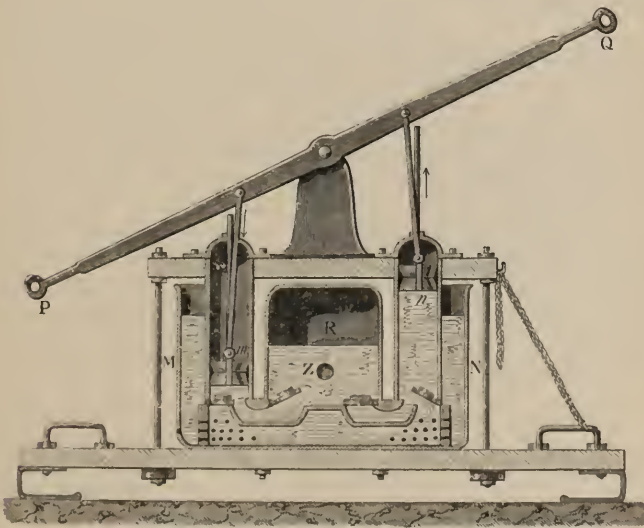

Fig. 218

220. **Fire-engine.**—The *fire-engine* is a force-pump in which a steady jet is obtained by the aid of an air-chamber, and also by two pumps working

alternately (fig. 218). The two pumps m and n , worked by the same lever, PQ , are immersed in a tank, which is kept filled with water as long as the pump works. From the arrangement of the valves it will be seen that when one pump, n , draws water from the tank, the other, m , forces it into the *air-chamber*, R ; whence, by an orifice, Z , it passes into the delivery tube, by which it can be sent in any direction.

Without the air-chamber the jet would be intermittent. But as the velocity of the water on entering the reservoir is less than on emerging, the level of the water rises above the orifice Z , compressing the air which fills the reservoir. Hence, whenever the piston stops, the air thus compressed, reacting on the liquid, forces it out during its momentary stoppage, and thus keeps up a constant flow.

BOOK V
ON SOUND

CHAPTER I

PRODUCTION, PROPAGATION, AND REFLECTION OF SOUND

221. **Province of acoustics.**—The study of sounds and that of the vibrations of elastic bodies form the province of the science of *sounds*, or *acoustics*.

Music considers sounds with reference to the pleasurable feeling they are calculated to excite. Acoustics is concerned with the questions of the production, transmission, and comparison of sounds; to which may be added the physiological question of the perception of sounds.

222. **Sound and noise.**—*Sound* is the peculiar sensation excited in the organ of hearing by the vibratory motion of bodies, when this motion is transmitted to the ear through an elastic medium.

Sounds are distinguished from *noises*. Sound properly so called, or *musical sound*, is that which produces a continuous sensation, the musical value of which can be estimated; while noise is either a sound of too short a duration to be determined, like the report of a cannon; or else it is a confused mixture of many discordant sounds, like the rolling of thunder or the noise of the waves. Nevertheless, the difference between sound and noise is by no means precise; Savart showed that there are relations of height in the case of noise, as well as in that of sound; and there are said to be certain ears sufficiently well organised to determine the musical value of the sound produced by a carriage rolling on the pavement.

223. **Cause of sound.**—When a tuning-fork is bowed it emits a sound. A body capable of emitting a sound is called a *sonorous body*. In the case of the tuning-fork we know that the prongs are in motion by their blurred appearance, if the amplitude be large, or, if the motion is too small to be detected by the eye, by placing the finger-nail close to the prong, when the motion will be felt. Generally, when a body emits sound the parts of it are in vibratory motion. It is not enough that the molecules are in motion. Mere molecular motion does not constitute sound. The molecules of a body are always in motion, and on the energy of this motion the temperature of

the body depends. The molecular motion may be increased or diminished without the consequent emission of sound. In order that sound may be produced the body must vibrate as a whole.

As understood in England and Germany, a vibration comprises a motion to *and fro*; in France, on the contrary, a vibration means a movement to *or fro*. The French vibrations are with us semi-vibrations; an *oscillation* or *vibration* is the movement of the vibrating particle in only one direction; a *double* or *complete vibration* comprises the oscillation both backwards and forwards (56). Vibrations of sounding bodies are very readily observed. If a light powder is sprinkled on a body which is in the act of yielding a musical

sound, a rapid motion is imparted to the powder, which renders visible the vibrations of the body; and, in the same manner, if a stretched cord is smartly pulled and let go, its vibrations are apparent to the eye.

A bell-jar is held horizontally in one hand (fig. 219), and made to vibrate by being struck with the other; if then a piece of metal is

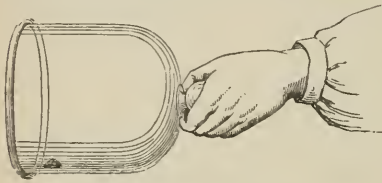

Fig. 219

placed in it, it is rapidly raised by the vibrations of the side; touching the bell-jar with the hand, the sound ceases, and with it the motion of the metal.

224. Sounds not propagated in vacuo.—

The vibrations of elastic bodies can only produce the sensation of sound in us by the intervention of a medium interposed between the ear and the sonorous body and vibrating with it. This medium is usually the air; but also gases, vapours, liquids, and solids also transmit sounds.

The following experiment shows that the presence of a propable medium is necessary for the propagation of sound. A small metal bell, which is continually struck by a small hammer by means of clockwork, or else an ordinary musical box, is placed under the receiver of an air-pump (fig. 220). So long as the receiver is full of air at the ordinary pressure the sound is transmitted; but in proportion as the air is exhausted the sound becomes feebler, and cannot be heard in a vacuum.

To ensure the success of the experiment, the bellwork or the musical box must be placed on wadding or on a block of vul-

canised rubber; for otherwise the vibrations would be transmitted to the air through the plate of the pump.

225. Sound is propagated in all elastic bodies.—If, in the above experiment, any vapour or gas is admitted after the vacuum has been made,

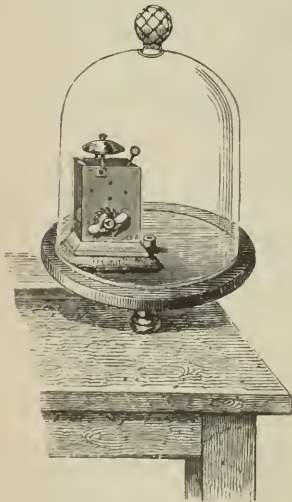

Fig. 220

the sound of the bell will be heard, showing that sound is propagated in this medium as in air.

Sound is also propagated in liquids. When two stones are struck against each other under water, the shock is distinctly heard; and a diver at the bottom of the water can hear the sound of voices on the bank. The sound is, however, enfeebled, as a considerable portion is reflected at the boundary of the two media.

When a tuning-fork is struck, not too violently, the sound is scarcely audible at the distance of a few feet from the fork. But if a prong of the fork while still vibrating touches the surface of water in a tumbler which rests on the table, the sound becomes distinct, proving that the vibrations of the fork are transmitted through the water to the glass and the table. If the tumbler rests on the sounding-box belonging to the fork (251) the effect is more striking.

The conductivity of solids is such that the faint scratching of a pen or the ticking of a watch at one end of a long horizontal wooden rod is heard much more distinctly when the ear is directly applied against the other end of the rod than when it is at the same distance in the air. Sound may even reach the ear through solids alone without passing through the air; for if the ears be closed, and the rod be put between the teeth, the ticking is distinctly heard. The earth conducts sound so well that at night, when the ear is applied to the ground, the stepping of horses, or any other noise at a great distance, is heard.

226. Waves in an elastic medium. Transverse and longitudinal vibrations. Propagation of sound in air.—When a disturbance is made at any point of a medium, such as a gas or liquid or the luminiferous ether, the particles of the medium are set in vibration, and the vibrations are passed on to the neighbouring particles, so that waves are formed which travel with a uniform velocity depending upon the medium, and by these the disturbance is propagated to considerable distances from its point of origin. The waves are due to the vibrations of the particles of the medium; the vibrations may be along the line in which the disturbance is travelling (as when sound is transmitted through solids, liquids, and gases), or at right angles to it (as in the case of light and radiant heat), or it may partake of both motions at the same time (water-waves).

Consider the case of transverse vibrations. Imagine a row of equidistant particles of a medium at rest, and suppose that when one of them is set in vibration at right angles to the row the disturbance is passed on from particle to particle, each in turn going through the same motions as its predecessors. Let the motion be simple harmonic (57). If T represents the periodic time, and if each particle starts from its mean position, $T/12$, after its next preceding, the state of things after intervals $\frac{T}{6}, \frac{T}{3}, \frac{T}{2}, T$, is shown in fig. 221 (*a* to *e*).

Thus the vibrations of the particles, each passing in succession through the same phases as the others, give rise to waves, each consisting of an elevation and depression, or crest and furrow. The length of a wave is the distance from crest to crest or from furrow to furrow, or between any two points in the same phase.

An illustration of wave-formation is obtained by observing what occurs when a small stone is dropped into smooth water. A depression is caused at the point of incidence, surrounded immediately by a circular ridge of water higher than the level of the smooth water. As this elevated portion sinks by its weight, it causes the water in front of it to rise, and thus the appearance is presented of a ridge followed by a trough travelling outwards from the point of disturbance. The ridge and trough constitute a wave, and this wave

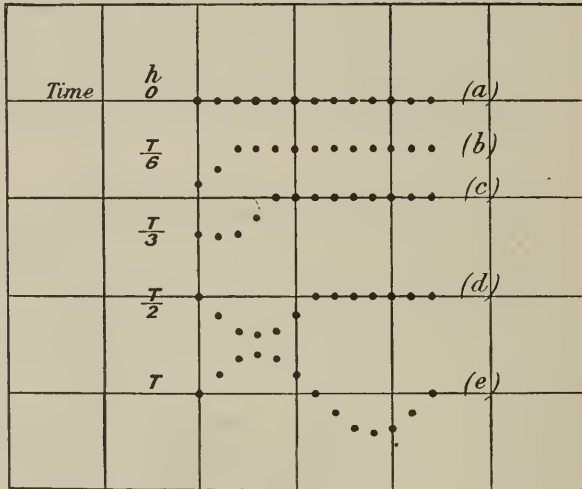

Fig. 221

is followed by a succession of others. The wave-form travels along the surface of the water; the particles of water merely move up and down, they do not move away from their mean positions. Their motion is not purely transversal, but is partly longitudinal, so that the particles of water on the surface move in circular paths.

Next consider sound-waves in air. Sound is transmitted through air by waves which are due to the vibrations of air particles. But in the case of sound the vibrations of the air particles are in the direction of propagation, they are longitudinal. Consequently, in place of elevations and depressions a sound-wave is composed of two portions, in one of which the air-pressure is greater, and in the other less, than normal.

Let AB be a line of equidistant air particles at rest, and let each particle when disturbed perform simple harmonic motion. If the vibrations were transverse a wave-form would be produced as shown in fig. 222 (a), the particles A, C, and B being at rest. If the vibrations take place along the line AB, then, in order to find the resulting configuration, we must displace the particles by an amount equal to the ordinate of the corresponding point in curve (a), *towards* A for the elevation and *from* A for the depression (fig. 222, b).

In fig. 223 the top line shows a row of equidistant particles at rest. At the time zero these particles are supposed to be in the positions shown, and the

rows below represent the relative positions of the particles after times $T/12$, $2T/12$, &c., T being the periodic time. The figure clearly shows the progression in time of a compression, and also of a rarefaction from the left towards the right.

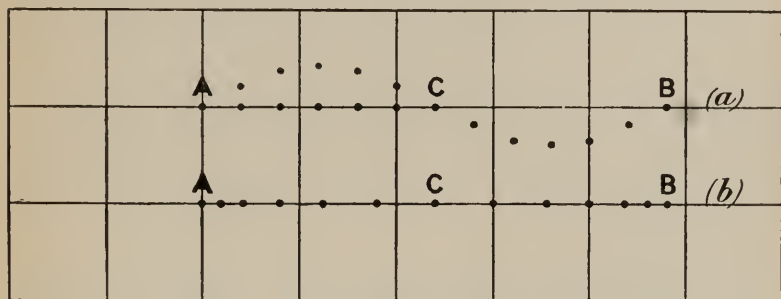

Fig. 222

The variations in local pressure as a sound-wave passes through air may be illustrated by considering a particular case. Let MN (fig. 224) be a

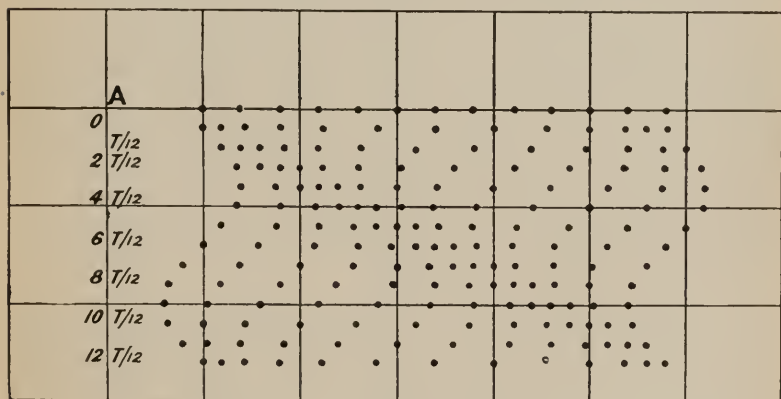

Fig. 223

tube filled with air at a constant pressure and temperature, and let P be a piston oscillating rapidly from A to a . When the piston starts from A ,



Fig. 224

it compresses the air in front of it, and the compression increases until P reaches the position halfway between A and a , when it is a maximum, after

which it diminishes as P reaches a . Suppose that as the piston moves from A to a , the disturbance of the air in the tube travels to H. Thus in aH the pressure of the air is greater than normal, the compression being greatest at the centre. When the piston returns in the direction aA , the pressure behind it is diminished and the diminution of pressure is a maximum when P is halfway back. This reduction of pressure or rarefaction travels along the tube in the same way and at the same rate as the compression, so that when the piston has reached A, the point from which it started, the compression has advanced to the position HH' , and its place has been taken by the rarefied portion. Thus after one complete oscillation of the piston the beginning of the air disturbance is at H' and the end at a . The whole length aH' is a wave or undulation. It consists of two equal parts in one of which the air is more compressed and in the other is more rarefied than in the undisturbed tube.

When the piston has made another complete oscillation, the wave aH' will have advanced by a distance equal to itself, and its place will have been taken by another wave, and so on. The velocity with which the disturbance travels is the velocity of sound in the air of the tube. If λ denotes the length of a wave, and n is the number of oscillations of the piston per second, $n\lambda$ is equal to the total distance travelled by the beginning of the disturbance in one second. If this distance is v , then the velocity of sound $= v = n\lambda$.

It is an easy transition from the explanation of the motion of sound-waves in a cylinder to that of their motion in an unenclosed medium. It is simply necessary to apply in all directions to each molecule of the vibrating body what has been said about a piston movable in a tube. A series of spherical waves alternately condensed and rarefied is produced around each centre of disturbance. As these waves are contained within two concentric spherical surfaces, whose radii gradually increase while the length of the undulation remains the same, their mass increases with the distance from the centre of disturbance, so that the amplitude of the vibration of the molecules gradually lessens, and the intensity of the sound, which depends upon the square of the amplitude, diminishes.

In the case of a water-wave travelling along the surface, the vertical displacement of a water particle from its mean position is being continually changed, as is also its velocity. When the velocity is zero the displacement is a maximum, *i.e.* the particle is on the top of a crest or at the bottom of a furrow; and when the particle occupies its mean position its velocity is a maximum. The corresponding phenomena in a sound-wave are displacement of the air particles and change of pressure. The change of pressure vanishes when the displacement is a maximum, and has its greatest value when the air particle occupies its mean position. This is made clear by a consideration of figs. 222, 223. Hence the transmission of a sound-wave is a transmission of changes of pressure and changes of displacement of the air; pressure and displacement are always changing in inverse directions.

Waves may start from many points of disturbance at the same time. They are all transmitted one through the other without modifying either their lengths or their velocities. When two waves meet each other the effect will be an augmentation or diminution of sound according to the relative phases in which the waves meet. If the surface of still water is

disturbed at two or more points, the coexistence of waves becomes sensible to the eye.

227. **Causes which influence the intensity of sound.**—Many causes modify the force or the *intensity* of sound. These are the distance of the sounding body, the amplitude of the vibrations, the density of the air at the place where the sound is produced, the direction of the currents of air, and, lastly, the neighbourhood of other sounding bodies.

i. *The intensity of sound is inversely as the square of the distance of the sounding body from the ear.* This law has been deduced by calculation, assuming the sound to radiate from a point, but it may be also demonstrated experimentally. Let us suppose several sounds of equal intensity—for instance, bells of the same kind, struck by hammers of the same weight falling from equal heights. If four of these bells are placed at a distance of 20 yards from the ear, and one at a distance of 10 yards, it is found that the single bell produces a sound of the same intensity as the four bells struck simultaneously. Consequently, for double the distance the intensity of the sound is only one-fourth. A method of comparing the intensities of different sounds will be described afterwards (291).

The distance at which sounds can be heard depends on their intensity. The report of a volcano at St. Vincent was heard at Demerara, 300 miles off, and the firing at Waterloo was heard at Dover.

ii. *The intensity of sound increases with the amplitude of the vibrations of the sonorous body.* The connection between the intensity of the sound and the amplitude of the vibrations (56) is readily observed by means of vibrating strings (267). For, if the strings are somewhat long, the oscillations are perceptible to the eye, and it is seen that the sound is feebler in proportion as the amplitude of the oscillations decreases. The intensity varies as the square of the amplitude of oscillation.

iii. *The intensity of sound depends on the density of the air in the place in which it is produced.* As we have already seen (224), when an alarm actuated by clockwork is placed under the bell-jar of an air-pump, the sound becomes weaker in proportion as the air is rarefied.

In hydrogen, which is about $\frac{1}{14}$ the density of air, sounds are much feebler than in air, although the pressure is the same. In carbonic acid on the contrary, whose density is 1.529, sounds are more intense. On high mountains, where the air is much rarefied, it is necessary to speak with some effort in order to be heard, and the discharge of a gun produces only a feeble sound. The ticking of a watch is heard in water at a distance of 23 feet, in oil of $16\frac{1}{2}$, in alcohol of 13, and in air of only 10 feet.

iv. *The intensity of sound is modified by the motion of the atmosphere and the direction of the wind.* In calm weather sound is always better propagated than when there is wind; in the latter case, for an equal distance, sound is more intense in the direction of the wind than in the contrary direction.

v. Lastly, *sound is strengthened by the neighbourhood of a sonorous body.* A string made to vibrate in free air has but a very feeble sound; but when it vibrates above a sounding-box, as in the case of the violin, guitar, or violoncello, its sound is much stronger. This arises from the fact that the box and the air which it contains vibrate in unison with the string. Hence the use of *sounding-boxes* in stringed instruments.

Attempts have been made to get a measure of the loudness of sound which should serve as a standard, by allowing leaden bullets to fall from various heights on an iron plate of some size. It appears that within certain limits the loudness is nearly proportional to the square root of the height from which the bullet falls, and not to the height itself. It thus appears that only a portion of the energy of the falling body is expended in producing vibrations of the plate.

228. **Influence of tubes on the transmission of sound.**—The law that the intensity of sound decreases in proportion to the square of the distance does not apply to the case of tubes, especially if they are straight and cylindrical. The sound-waves in that case are not propagated in the form of increasing concentric spheres, and sound can be transmitted to a great distance without any perceptible alteration. Biot found that in one of the Paris water-pipes, 1040 yards long, the voice lost so little of its intensity that a conversation could be kept up at the ends of a tube in a very low tone. The weakening of sound becomes, however, perceptible in tubes of large diameter, or where the sides are rough. This property of transmitting sounds was first used in England for *speaking tubes*. They consist of india-rubber or metal tubes, smooth inside and as free as possible from bends, passing from one room to another. If a person speaks at one end of the tube, he is distinctly heard by a person with his ear at the other end.

From Biot's experiments it is evident that a communication might be made between two towns by means of speaking tubes. The velocity of sound is 1125 feet in a second at 16.6° C., so that a distance of 50 miles would be traversed in four minutes.

229. **Regnault's experiments.**—Theoretically, a sound should be propagated in a straight cylindrical tube with a constant intensity. Regnault found, however, that in these circumstances the intensity of sound gradually diminishes with the distance, and that the distance at which it ceases to be audible is nearly proportional to the diameter of the tube.

He reproduced sound-waves of equal strength by means of a small pistol charged with a gramme of powder, and fired at the open ends of tubes of various diameters; and he then ascertained the distance at which the sound could no longer be heard, or at which it ceased to act on what he calls a *sensitive membrane*. This was a very flexible membrane which could be fixed across the tube at various distances, and was provided with a small metal disc in its centre. When the membrane began to vibrate, this disc struck against a metallic contact, and thereby closed a voltaic circuit, which traced on a chronograph the exact moment at which the membrane received the sound-wave.

Experimenting in this manner, Regnault found that the report of a pistol charged as stated is no longer audible at a distance of

1159 metres in a tube of	0.108m. diameter
3810 " "	0.300m. "
9540 " "	1.100m. "

These numbers represent the limit of distance at which the sound-wave is no longer heard, but it still acts on the membrane at the distances of 4156, 11,430, and 19,851 metres respectively.

According to Regnault the principal cause of this diminution of intensity is the loss of energy against the sides of the tube ; he found also that sounds of high pitch are propagated in tubes less easily than those of low pitch : a bass voice would be heard at a greater distance than a treble voice.

230. **Velocity of sound in air.**—Since the propagation of sound-waves is gradual, sound requires a certain time for its transmission from one place to another, as is seen in numerous phenomena. For example, the sound of thunder is only heard some time after the flash of lightning has been seen, although both the sound and the light are produced simultaneously ; and in like manner we see a mason at a distance in the act of striking a stone, or a man felling a tree, before we hear the sound.

The velocity of sound in air has often been the subject of experimental research. One of the most accurate of the direct measurements was made by Moll and Van Beck in 1823. Two hills, near Amsterdam, Kooltjesberg and Zevenboomen, were chosen as stations : their distance from each other as determined trigonometrically was 57,971 feet, or nearly eleven miles. Cannon were fired at stated intervals simultaneously at each station, and the time which elapsed between seeing the flash and hearing the sound was noted by chronometers. This time could be taken as that which the sound required to travel between the two stations ; for it will be subsequently seen that light takes an inappreciable time to traverse the above distance. Introducing corrections for the temperature and hygrometric state, and eliminating the influence of the wind, Moll and Van Beck's results as recalculated by Schröder van der Kolk gave 1092.78 as the velocity of sound in feet per second in dry air at 0° C.

The velocity of sound at 0° may be taken at 1093 feet, or 333 metres per second. It increases with increase of temperature, and may be calculated for a temperature t° from the formula

$$v = 1093\sqrt{(1 + 0.003665t)},$$

where 1093 is the velocity in feet per second at 0° C., and 0.003665 the coefficient of expansion of air. This amounts to an increase of nearly 2 feet for every degree Centigrade. Kendall, in a North Pole expedition, found that the velocity of sound at a temperature of -40° was 314 metres or 1030.4 feet. Stone's determinations, made at the Cape of Good Hope with very great care, gave 1090.57 feet, or 332.4 metres, as the velocity of sound at 0°. Greely determined the velocity of sound in metres per second in air between -10° and -45° to be

$$v = 333 + 0.6t,$$

where t is the temperature Centigrade. For the same temperature it is independent of the density of the air, and consequently of the pressure. It is the same for the same temperature with all sounds, whether they are strong or weak, deep or acute. Biot found, in his experiments on the conductivity of sound in tubes, that when a well-known air was played on a flute at one end of a tube 1040 yards long, it was heard without alteration at the other end, from which he concluded that the velocity of different sounds is the same. For the same reason the tune played by a band is heard at a great distance without

alteration, except in loudness, which could not be the case if sounds differing in pitch and intensity travelled with different velocities.

This cannot, however, be admitted as universally true. Earnshaw, as the result of a mathematical investigation of the laws of the propagation of sound, concluded that the velocity of a sound depends on its strength; and, accordingly, that a violent sound ought to be propagated with greater velocity than a gentler one. This conclusion is confirmed by an observation made by Captain Parry on his Arctic expedition. During artillery practice it was found, by persons stationed at a considerable distance from the guns, that the report of the cannon was heard before the command to fire given by the officer. And, more recently, Mallet made a series of experiments on the velocity with which sound is propagated in rocks, by observing the times which elapsed before blastings, made at Holyhead, were heard at a distance. He found that the larger the charge of gunpowder, and therefore the louder the report, the more rapid was the transmission. With a charge of 2000 pounds of gunpowder the velocity was 967 feet per second, while with a charge of 12,000 it was 1210 feet per second.

Jacques made a series of experiments by firing different weights of powder from a cannon, and determining the velocity of the report at different distances from the gun by means of an electric arrangement. He thus found that, close to the gun, the velocity is least, and that it increases to a certain maximum which is considerably greater than the average velocity. The velocity is also greater with the heavier charge. Thus with a charge of $1\frac{1}{2}$ pound the velocity was 1187, and with a charge of $\frac{1}{2}$ pound it was 1032 at a distance of from 30 to 50 feet; while at a distance of 70 to 80 it was 1267 and 1120; and at 90 to 100 feet it was 1262 and 1114 respectively.

Threlfall experimented with the explosion of charges in water at Port Jackson, Australia. The calculated velocity was 1500 metres per second; the observed velocity rose from 1752 metres per second with 9 ounces of gun-cotton to 2013 metres per second with 64 ounces.

Bravais and Martins found, in 1844, that sound travelled with the same velocity from the base to the summit of the Faulhorn as from the summit to the base.

A laboratory method of determining the velocity of sounds consists in using a metronome (83) which is beating slowly, and is approached to a wall until a position is found at which the echo of one beat coincides with the sound of another heard directly. The distance from the wall is then half the distance which sound traverses in the interval between two beats of the metronome.

231. **Calculation of the velocity of sound in gases.**—From theoretical considerations Newton gave a rule for calculating the velocity of sound in gases, which may be represented by the formula

$$v = \sqrt{\frac{e}{d}}$$

in which v represents the velocity of the sound, e the elasticity of the gas, and d its density.

This formula expresses that *the velocity of the propagation of sound in gases is directly as the square root of the elasticity of the gas, and inversely*

as the square root of its density. It is easy to prove that, if Boyle's law is applicable—that is, if the changes of volume take place without change of temperature—the elasticity of a gas is equal to its pressure. It follows that the velocity of sound is the same under any pressure; for although the elasticity increases with increased pressure, according to Boyle's law, the density increases in the same ratio. At Quito, where the mean barometric height is only 21·8 inches, the velocity is the same as at the sea-level, provided the temperature is the same.

If h is the height of the barometer, δ the density of mercury, and g the acceleration due to gravity, the pressure $P = g\delta h$; further, if d is the density of the gas at t° C. and d_0 the density at 0° C., $d_0 = d(1 + at)$, where a is the coefficient of expansion of the gas (332). Thus Newton's formula becomes

$$v = \sqrt{\frac{g\delta h}{d_0}(1 + at)}.$$

Substituting in this formula the values in centimetres and grammes, $g = 981$, $\delta = 13,596$, $h = 76$, $d_0 = 0\cdot001293$, the pressure is $1\cdot0135 \times 10^7$ dynes, or $1\cdot0135$ megadynes, per square centimetre, and the value of v is 27,995 centimetres per second = 279·95 metres per second, which is about one-sixth less than the experimental result. The reason for this discrepancy was given by Laplace, who pointed out that when sound-waves are travelling through air the heat which is produced by the increase of pressure in the compressed part of any wave does not rapidly escape into the surrounding air. Similarly the cold due to the diminution of pressure in the rarefied portion of the wave is not at once compensated by the ingress of heat from the surrounding space. Consequently the temperature in the two parts of any wave cannot be regarded as constant, and therefore Boyle's law does not hold. Although the average temperature of the air is unaltered, its elasticity is increased and is no longer measured by the pressure P . It may be shown that the elasticity is greater than the isothermal elasticity P in the proportion in which the specific heat of the gas at constant pressure is greater than the specific heat at constant volume. If these specific heats are denoted by c , c' respectively, the elasticity = $P \frac{c}{c'} = P\gamma$, and the expression for the velocity of sound in the gas is

$$v = \sqrt{\frac{e}{d}} = \sqrt{\frac{P\gamma}{d}} = \sqrt{\frac{g\delta h}{d_0}(1 + at)\gamma}.$$

The value of γ for air is 1·41, and if the value of the velocity obtained above, viz. 279·95 metres, be multiplied by $\sqrt{1\cdot41}$ or 1·1875, the product is 332·55, which agrees with the experimental value.

Knowing the velocity of sound, we can calculate approximately the distance at which it is produced. Light travels with such velocity that the flash or the smoke accompanying the report of a gun may be considered to be seen simultaneously with the occurrence of the explosion. Counting then the number of seconds which elapse between seeing the flash and hearing the sound, and multiplying this number by 1125, supposing the

temperature to be 16° C., we get the distance in feet at which the gun is discharged. In the same way the distance of thunder may be estimated.

232. **Velocity of sound in various gases.**—The velocity of sound in air and other gases may be determined by making use of the principle of resonance in air pipes. The method is described in article 276.

Since in gases which differ in density, but are subjected to the same pressure, the velocity of sound varies inversely as the square root of the density, knowing the velocity of sound in air, we may calculate it for other gases; thus in hydrogen it will be

$$\sqrt{\frac{1093}{0.0688}} = 4168 \text{ feet.}$$

Velocities calculated in this way cannot be universally accurate, for the coefficient $\frac{c}{c'}$ or γ differs somewhat in different gases. And when pipes were sounded with different gases, and the number of vibrations of the notes multiplied by twice the length of the pipe, numbers were obtained which differed from those calculated by the above formula. When, however, the proper value of γ for each gas was introduced into the calculation, the theoretical results agreed very well with the observed ones.

By the above method the following values have been obtained :—

Velocity of sound at 0° C. in

Chlorine	677 feet in a second
Carbonic acid	856 " "
Oxygen	1040 " "
Air	1093 " "
Carbonic oxide	1106 " "
Hydrogen	4163 " "

233. **Doppler's principle.**—When a sounding body approaches the ear, the note perceived is somewhat higher than the true one; but if the source of sound recedes from the ear, the note perceived is lower. The truth of this, which is known as *Doppler's principle*, will be apparent from the following considerations :—When the source of sound and the ear are relatively at rest, the ear receives n waves in a second; but if the ear approaches the sound, or the sound approaches the ear, it receives more; just as a ship meets more waves when it ploughs through them than if it is at rest. Conversely, the ear receives a smaller number when it recedes from the source of sound. The effect in the first case is as if the sounding body emitted more vibrations in a second than it really does, and in the second case fewer. Hence in the first case the note appears higher; in the second case lower.

If the distance which the ear traverses in a second towards the source of sound (supposed to be stationary) is s feet, and the wave-length of the particular note is λ feet, then $\frac{s}{\lambda}$ waves are passed in a second; this is equal to $\frac{ns}{v}$, for $\lambda = \frac{v}{n}$, where v is the velocity of sound (226). Hence the ear

receives not only the n original waves, but also $\frac{ns}{v}$ in addition. Therefore the number of waves per second which enter the ear is

$$n' = n + \frac{ns}{v} = n \left(1 + \frac{s}{v} \right)$$

for an ear which approaches the sound ; and by similar reasoning it is

$$n' = n - \frac{ns}{v} = n \left(1 - \frac{s}{v} \right)$$

for an ear receding from the sound.

To test Doppler's theory Buys Ballot stationed trumpeters on the Utrecht railway and also upon locomotives, and had the height of the approaching or receding notes compared with stationary ones by musicians. He thus found both the principle and the formula fully confirmed. Similar conclusive experiments were made by Scott Russell on English railways. The observation may often be made as one fast train passes another in which the engine is sounding its whistle. Suppose each train to be running at 30 miles an hour, the relative velocity is 60 miles an hour, or 88 feet per second. If we take $v = 1120$, $n' = n \left(1 + \frac{88}{1120} \right)$, $n'' = n \left(1 - \frac{11}{1120} \right)$, $\therefore \frac{n''}{n'} = \frac{151}{129} = 1.17$. Hence the note of the whistle is flattened, as the trains pass each other, by nearly a minor third (247).

It must be noted that the pitch of the whistle changes only at the moment the locomotive passes. It is constant as the train approaches, and constant again, but lower in pitch, as the train recedes.

Doppler's principle may also be established by direct laboratory experiments. Rollmann fixed a long rod on a turning table, at the end of which was a large glass bulb with a slit in it, which sounded like a humming-top when a tangential current of air was blown against the slit. The uniform and sufficiently rapid rotation of the sphere developed such a current, and produced a steady note, the pitch of which was higher or lower in each rotation according as the bulb came nearer, or receded from, the observer.

The principle may also be illustrated by means of a tuning-fork with wide branches, and producing a very high note of 2046 vibrations. When this is loudly sounded, and, being held in front of a smooth wall, is moved towards it with a velocity of a metre in a second, the direct note and that reflected from the wall undergo opposite changes, so that an observer may distinctly hear beats (263).

234. **Velocity of sound in liquids.**—The velocity of sound in water was experimentally determined in 1827 by Colladon and Sturm. They moored two boats at a known distance apart in the Lake of Geneva. The first supported a bell immersed in water, and a bent lever provided at one end with a hammer which struck the bell, and at the other with a lighted wick, so arranged that it ignited some powder the moment the hammer struck the bell. To the second boat was affixed an ear-trumpet, the bell of which was in water, while the mouth was applied to the ear of the observer, so that he could measure the time between the flash of light and the arrival

of sound by the water. By this method the velocity was found to be 4708 feet in a second at the temperature 8.1° , or four times as great as in air.

The velocity of sound, which is different in different liquids, can be calculated by a formula, identical with that given above (231) as applicable to gases—that is, $v = \sqrt{\frac{e}{d}}$. In this formula, e is the volume elasticity of the liquid—that is, the ratio of pressure applied to the compression produced—and d its density. The compression per unit of volume due to the application of a pressure of one atmosphere is called the compressibility of the liquid. The numbers given in the following table were computed from the above formula. As in the case of gases, the velocity varies with the temperature, which is therefore appended in each case.

River water (Seine)	13° C.	= 4714 feet in a second
” ” ”	30°	= 5013 ”
Artificial sea water	20°	= 4761 ”
Mercury	10°	= 4866 ”
Solution of common salt	18°	= 5132 ”
Absolute alcohol	23°	= 3854 ”
Turpentine	24°	= 3976 ”
Ether	24°	= 3801 ”

It will be seen how close is the agreement between the two values for the velocity of sound in water, the only case in which they have been directly compared. There is considerable uncertainty about the values for other liquids, owing to the doubt as to the values for their compressibility.

235. Velocity of sound in solids.—As a general rule, the elasticity of solids, as compared with the density, is greater than that of liquids, and consequently the propagation of sound is more rapid.

The difference is well seen in an experiment by Biot, who found that when a bell was struck by a hammer at one end of an iron tube 3120 feet long, two sounds were distinctly heard at the other end. The first of these was transmitted by the tube itself with a velocity, x ; and the second by the enclosed air with a known velocity, a . The interval between the sounds was 2.5 seconds. The value of x obtained from the equation

$$\frac{3120}{a} - \frac{3120}{x} = 2.5$$

shows that the velocity of sound in the tube is nearly nine times as great as that in air.

Biot's experiment is an interesting one, though no great value can be attached to the result, as the pipe was not continuous, but formed a series of jointed tubes.

That the report of the firing of cannon is heard at far greater distances than peals of thunder is doubtless owing to the fact that the sound in the former case is mainly transmitted through the earth.

To this class of phenomena belongs the fact that if the ear is held against a rock in which a blasting is being made at a distance, two distinct reports

are heard—one transmitted through the rock to the ear, and the other transmitted through the air. The propagation of sound in solids is also well illustrated by the fact that in laying telegraph wires the filing at any particular part can be heard at distances of miles by placing one end of the wire in the ear. The *toy telephone* also is based on this fact.

The velocity of sound in wires has also been determined theoretically, by Wertheim and others, by the formula $v = \sqrt{\frac{\mu}{d}}$ in which μ is the longitudinal elasticity (Young's modulus) of the material (87), while d is the density.

This may be illustrated from a determination by Wertheim of the velocity of sound in a specimen of annealed steel wire, the density s of which was 7.631 and longitudinal elasticity 21.4×10^{11} (87). The formula gives

$$v = \sqrt{\frac{21.4 \times 10^{11}}{7.63}} = 5294 \times 10^3 \frac{\text{cm.}}{\text{sec.}} = 5294 \text{ metres per sec.} = 17,370 \text{ ft. per sec.}$$

The following table gives the velocity in various bodies, expressed in feet per second, mostly from the experimental determinations of Wertheim and of Stefan :—

India rubber	100 to 200	Copper	12194
Tallow	1180	Oak	12622
Wax	2394	Cedar	13120
Paraffin	4250	Elm	13516
Lead	4653	Ash	15314
Membranes	2300 to 6560	Fir	15316
Gold	7021	Walnut	15744
Paper	5250 to 8860	Glass	16057
Silver	8806	Steel wire	16336
Pine	10900	Wrought iron and steel	16498

The numbers for india rubber are of the same order of magnitude as those for the propagation of a nervous impulse, and suggest that such an impulse is transmitted by longitudinal vibrations (283) like those of sound.

In the case of wood these velocities are in the directions of the fibres, and are considerably greater than across the rings or along the rings; thus with fir the velocities are 4382 and 2572 for these directions respectively.

From a recent determination of the elasticity of ice, Trowbridge and Macrae deduced the velocity of sound in it to be 9600 feet per second, or about nine times that of air.

Mallet investigated the velocity of the transmission of sound in various rocks, and found that it is as follows :—

Wet sand	825 feet in a second
Contorted, stratified quartz and slate rock	1088 „
Discontinuous granite	1306 „
Solid granite	1664 „

A direct experimental method of determining the velocity of sound in solids, gases, and vapours will be described subsequently (279).

If a medium through which sound passes is heterogeneous, the waves of sound are reflected on the different surfaces, and the sound becomes rapidly enfeebled. Thus a soft earth conducts sound badly, while a hard ground which forms a compact mass conducts it well. So also we hear badly through air-spaces which are filled with porous materials, such as shavings, sawdust, cinders, and the like.

236. **Reflection of sound.**—So long as sound-waves diverging from a point are not obstructed in their motion they are propagated in the form of concentric spheres; but when they meet with an obstacle they follow the general law of elastic bodies; that is, they return upon themselves, forming new concentric waves, which seem to emanate from a second centre on the other side of the obstacle. This phenomenon constitutes the reflection of sound.

Fig. 225 represents a series of incident waves reflected from an obstacle, PQ. Taking for example the incident wave MCDN, emitted from the centre A, the corresponding reflected wave is represented by the arc CKD of a circle whose centre α is as far behind the obstacle PQ as A is before it.

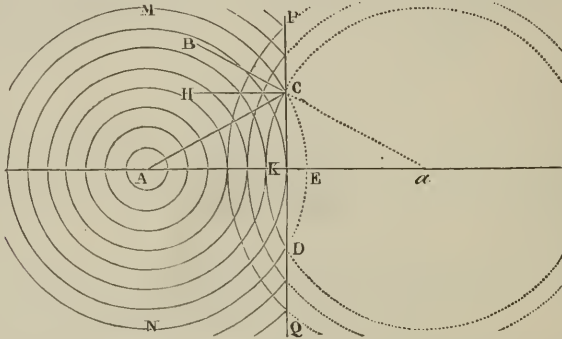

Fig. 225

If any point, C, of the reflecting surface is joined to the centre of sound, and if the perpendicular CH is let fall on the surface of this body, the angle ACH is called the *angle of incidence*, and the angle BCH, formed by the prolongation of aC, is the *angle of reflection*.

The reflection of sound is subject to the two following laws:—

- I. *The angle of reflection is equal to the angle of incidence.*
- II. *The incident sonorous ray and the reflected ray are in the same plane perpendicular to the reflecting surface.*

From these laws it follows that the wave, which in the figure is propagated in the direction AC, takes the direction CB after reflection, so that an observer placed at B hears a second sound, which appears to come from C, besides the sound proceeding from the point A.

The laws of the reflection of sound are the same as those for light and radiant heat, and may be demonstrated by similar experiments. One of the simplest of these is made with conjugate mirrors (see chapter on Radiant Heat); if in the focus of one of these mirrors a watch is fixed, the ear placed in the focus of the second mirror hears the ticking very distinctly

even when the mirrors are at a distance of 12 or 13 yards. The mirrors should be large, so that the head may obstruct the sound-waves as little as possible. With smaller mirrors the bell of an ear trumpet is held at the focus, and the tube end is placed in the ear, which is held on one side of the mirror.

In like manner, the explosion of fulminating mercury in the focus of one mirror causes that of iodide of nitrogen placed in that of the other.

237. **Echoes and resonances.**—An *echo* is the repetition of a sound in the air, caused by its reflection from some obstacle.

A very sharp quick sound can produce an echo when the reflecting surface is 55 feet distant; but for articulate sounds at least double that distance is necessary, for it may be easily shown that no one can pronounce or hear distinctly more than five syllables in a second. Now, as the velocity of sound at ordinary temperatures may be taken at 1125 feet in a second, in a fifth of that time sound would travel 225 feet. If the reflecting surface is 112·5 feet distant, in going and returning sound would travel through 225 feet. The time which elapses between the articulated and the reflected sound would, therefore, be a fifth of a second, the two sounds would not interfere, and the reflected sound would be distinctly heard. A person speaking with a loud voice in front of a reflector, at a distance of 112·5 feet, can only distinguish the last reflected syllable: such an echo is said to be *monosyllabic*. If the reflector were at a distance of two or three times 112·5 feet, the echo would be *dissyllabic*, *trisyllabic*, and so on.

When the distance of the reflecting surface is less than 112·5 feet, the direct and the reflected sound are confounded. They cannot be heard separately, but the sound is strengthened. This is what is often called *resonance* or *reverberation*, and is frequently observed in large rooms. Bare walls and smooth surfaces especially give rise to this effect. In the Black-wall tunnel near London, which is lined with smooth masonry, the noise of passing vehicles is deafening, and conversation is difficult. The presence of an audience in a large bare room may render it possible to hear speaking, where without an audience the distinctness of the direct voice is destroyed by its echoes. When the reflecting surface is not far from the source of sound, as in the case of a sounding board over the head of a preacher in a church, the direct and reflected waves meet the ear of a person at a distance at practically the same instant, and the sound is strengthened. Tapestry and hangings deaden the sound by breaking up the sound waves and preventing reflection. To control or eliminate the effects of resonance is a difficult problem in the acoustics of the building art.

Multiple echoes are those which repeat the same sound several times; this is the case when two opposite surfaces (for example, two parallel walls) successively reflect sound. There are echoes which repeat the same sound 20 or 30 times. An echo in the château of Simonetta, in Italy, repeats a sound 30 times. At Woodstock there is one which repeats from 17 to 20 syllables.

As the laws of reflection of sound are the same as those of light and heat, curved surfaces produce *acoustic foci* like the luminous and calorific foci produced by concave reflectors. If a person standing under the arch of a bridge speaks with his face turned towards one of the piers, the sound is

reproduced near the other pier with such distinctness that a conversation can be kept up in a low tone, which is not heard by anyone standing in the intermediate spaces.

There is a square room with an elliptical ceiling on the ground floor of the Conservatoire des Arts et Métiers in Paris which presents this phenomenon in a remarkable degree to persons standing in the two foci of the ellipse.

Whispering galleries are formed of smooth walls having a continuous curved form. The mouth of the speaker is presented at one point, and the ear of the hearer at another and distant point. In this case the sound is successively reflected from one point to the other until it reaches the ear.

In the whispering gallery of St. Paul's the faintest sound is thus conveyed from one side to the other of the dome, but it is not heard at any intermediate points. Placing himself close to the upper wall of the Colosseum, a circular building 130 feet in diameter, Wheatstone found a word to be repeated a great many times. A single exclamation sounded like a peal of laughter, while the tearing of a piece of paper resembled the patter of hail.

It is not merely by solid surfaces, such as walls, rocks, ships' sails, &c., that sound is reflected. It is also reflected by clouds, and it has even been shown by direct experiment that a sound in passing from a gas of one density into another is reflected at the surface of separation as it would be against a solid surface. Now, different parts of the earth's surface are unequally heated by the sun, owing to the shades of trees, evaporation of water, and other causes, so that in the atmosphere there are numerous ascending and descending currents of air of different density. Whenever a sound-wave passes from a medium of one density into another it undergoes partial reflection, which, though not strong enough to form an echo, distinctly weakens the direct sound. This is doubtless the reason, as Humboldt remarked, why sound travels further at night than at daytime, even in the South American forests, where the animals, which are silent by day, fill the atmosphere at night with thousands of confused sounds. To this may be added that at night and in repose, when other senses are at rest, that of hearing becomes more acute. This is the case with persons who have become blind.

It has generally been considered that fog in the atmosphere is a great deadener of sound ; it being a mixture of air and globules of water, at each of the innumerable surfaces of contact a portion of the vibration is lost. The evidence as to the influence of this property is conflicting ; Tyndall's researches show that a white fog, or snow, or hail, is not an important obstacle to the transmission of sound, but that aqueous vapour is. Experiments made on a large scale, in order to ascertain the best form of fog signals, gave remarkable results.

On some days, which optically were quite clear, certain sounds could not be heard at a distance far inferior to that at which they could be heard even during a thick haze. Tyndall ascribed this result to the presence in the atmosphere of aqueous vapour, which forms in the air innumerable striæ that do not interfere with its optical clearness, but render it acoustically turbid, the sound being reflected by this invisible vapour just as light is by the visible cloud.

These conclusions, first drawn from observations, have been verified by

laboratory experiments. Tyndall showed that a medium consisting of alternate layers of light and heavy gas, such as coal gas and carbonic acid, deadens sound, and also that a medium consisting of alternate strata of heated and ordinary air exerts a similar influence. The same is the case with an atmosphere containing the vapours of volatile liquids. So long as the continuity of air is preserved, sound has great power of passing through the interstices of solids; thus it will pass through twelve folds of a dry silk handkerchief, but is stopped by a single layer if it is wetted.

238. **Refraction of sound.**—It will be found afterwards that *refraction* is the change of direction which light and heat experience on passing from one medium to another. It has been shown by Hajech that the laws of the refraction of sound are the same as those for light and heat; he used tubes filled with various gases and liquids, and closed by membranes; the membrane at one end was at right angles to the axis of the tube, while the other made an angle with it. When these tubes were placed in an aperture in the wall between two rooms, a sound produced in front of the tube in one room, that of a tuning-fork for instance, was heard in directions in the other varying with the inclination of the second membrane, and with the nature of the substance with which the tube was filled. Accurate measurements showed that the law held that the sines of the angles of incidence and refraction are in a constant ratio, and that this ratio is equal to that of the velocity of sound in the two media.

Thus the velocity of sound in water is not very different from that in hydrogen, and they produce deviations which are nearly equal.

Sondhauss confirmed the analogy of the refraction of sound-waves to those of light and heat. He constructed lenses of gas by cutting equal segments out of a large collodion balloon, and fastening them on the two

sides of a sheet-iron ring a foot in diameter, so as to form a double convex lens about 4 inches thick in the centre (fig. 226). This was filled with carbonic acid, and a watch, A, was placed in the direction of the axis; the point was then sought on the other side of the lens at which the sound was most distinctly heard. It was found that when the ear was removed from the axis the sound was scarcely perceptible, but that at a certain point B on the

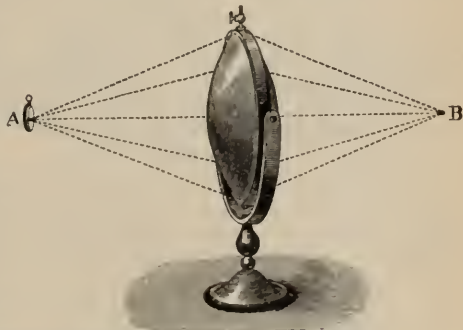

Fig. 226

axial line it was very distinctly heard. Consequently, the sound-waves in passing from the lens had converged towards the axis; their direction had been changed; in other words, they had been refracted.

The refraction of sound may be easily demonstrated by means of one of the very thin india-rubber balloons used as children's toys, inflated by carbonic acid. If, however, the balloon is filled with hydrogen, no focus

is detected ; it acts like a concave lens, and the divergence of the rays is increased, instead of their being converged to the ear.

A direct proof of the refraction of sound is given by the experiments of Schellbach and Böhm. The source of sound was a film of collodion stretched across a ring ab (fig. 227), which was put in vibration by electric sparks at o . A disc of paper, p , sprinkled with fine charcoal powder, was suspended in the vessel BB' . When this vessel contained air, rings of dust were formed, the centre of which was at f in the direction of the propagation of the sound. But if the vessel was filled with carbonic acid the centre of the rings was found to be at f' , showing that the sound had been refracted towards the perpendicular on passing from air into the denser medium ; and measurements showed that the position of the point f' was in accordance with the law of refraction for light. Experiments suitably modified showed that, when hydrogen was substituted for carbonic acid, the sound was bent away from the perpendicular.

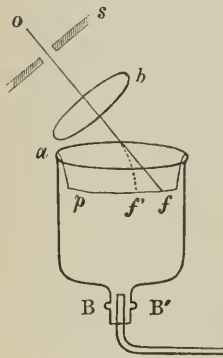

Fig. 227

It has long been known that sound is propagated in a direction against that of the wind with less velocity than with the wind. This is probably due to a refraction of sound on a large scale. The velocity of wind along the ground is always considerably less than at a greater height ; thus, the velocity at a height of 8 feet has been observed to be double what it is at a height of 1 foot above the ground. Hence a wave-front, originally vertical, becomes tilted upwards with the lower part forward ; and, as the direction of the wave-motion is at right angles to the front of the wave, the effect of the coalescence of a number of these

rays, thus directed upwards, is to produce an increase of the sound in the higher regions. The rays which travel with the wind will, for similar reasons, be refracted downwards, and thus the sound be better heard.

239. **Speaking trumpet. Ear trumpet.**—These instruments depend on the reflection of sound in tubes.

The *speaking trumpet*, as its name implies, is used to render the voice audible at great distances, more especially on board ship. It consists of a slightly conical tin or brass tube (fig. 228), very much wider at one end (which



Fig. 228

is called the *bell*), and provided with a mouthpiece at the other. Speaking trumpets are sometimes as much as 7 feet in length, the bell being 1 foot in diameter.

The larger the dimensions of this instrument the greater is the distance at which the voice is heard. Its action is usually ascribed to the successive reflections of sound-waves from the sides of the tube, by which the waves tend more and more to pass in a direction parallel to the axis of the instrument. It has, however, been objected to this explanation that the sounds emitted by the speaking trumpet are not stronger solely in the direction of the axis, but in all directions; that the bell would not tend to produce parallelism in the sound-wave, whereas it certainly exerts considerable influence in strengthening the sound. According to Hassenfratz, the bell acts by causing a large mass of air to be set in consonant vibration before it begins to be diffused. This is probably also the reason why sound travels best in the chief direction of the sounding body; thus the report of a cannon, the sound of a wind instrument in the line of the tube, the voice of the direction of the mouth, &c.

The *ear trumpet* is used by persons who are hard of hearing. It is essentially an inverted speaking trumpet, and consists of a conical metallic tube, one of whose ends, terminating in a *bell*, receives the sound, while the other end is introduced into the ear. This instrument is the reverse of the speaking trumpet. The bell serves as a mouthpiece; that is, it receives the sound coming from the mouth of the person who speaks. These sounds are transmitted by a series of reflections to the interior of the trumpet, so that the waves, which would become greatly diffused, are concentrated on the ear, and produce a far greater effect than divergent waves would have done.

240. **Stethoscope.**—One of the most useful applications of acoustical principles is the *stethoscope*. Figs. 229 and 230 represent an improved form of

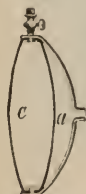

Fig. 229



Fig. 230

this instrument devised by König. Two sheets of india rubber, *c* and *a*, are fixed to the circular edge of a hollow metal hemisphere; the edge is provided with a stopcock, so that the sheets can be inflated, and then present the appearance of a double convex lens, as represented in section in fig. 229. To a tubulure on the hemisphere is fixed an india-rubber tube terminated by horn or ivory, *b*, which is placed in the ear (fig. 230).

When the membrane *c* of the stethoscope is applied to the chest of a sick person, the beating of the heart and the sounds of respiration are transmitted to the air in the chamber *a*, and thence to the ear by means of the flexible tube. If several tubes are fixed to the instrument, as many observers may simultaneously auscultate the same patient.

A recent application—that to the *water stethoscope*—has been found of

great service. It consists of a steel rod about three feet in length, with an enlargement at each end ; one of these is so shaped that it fits against a water-pipe, while the other is applied to the ear. The taps having been turned off, a skilled observer can detect the slight sound due to any flow of water, which, in the circumstances, must be due to leakage.

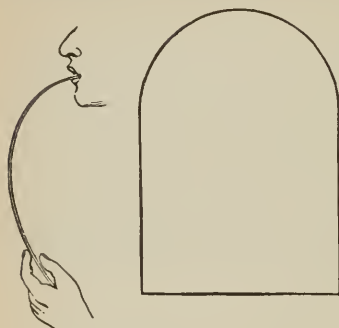

Fig. 231

The *audiphone*, invented by Mr. Rhodes, of Chicago, is of considerable service to people hard of hearing ; in its most simple form (fig. 231) it consists of a thin rectangular piece of fine cardboard, the square end of which is held in one hand while the opposite and convex edge is pressed against the teeth of the upper jaw so that it is slightly

bent : it receives the sounds which are produced in the air, and transmits them to the auditory nerves through the bones of the head.

CHAPTER II

MEASUREMENT OF THE NUMBER OF VIBRATIONS

241. **Savart's apparatus.**—*Savart's toothed wheel*, so called from the name of its inventor, is an apparatus by which the absolute number of vibrations corresponding to a given note can be determined. It consists of a solid oak frame in which are two wheels, A and B (fig. 232); the larger wheel, A, is connected with the toothed wheel by means of a strap and a multiplying wheel, thereby causing the toothed wheel to revolve with great velocity; a card, E, is fixed on the frame, and, in revolving, the toothed wheel strikes against it and causes it to vibrate. The card, being struck by each tooth, makes as many vibrations as there are teeth. At the side of the apparatus is an indicator, H, which gives the number of revolutions of the wheel, and consequently the number of vibrations in a given time.

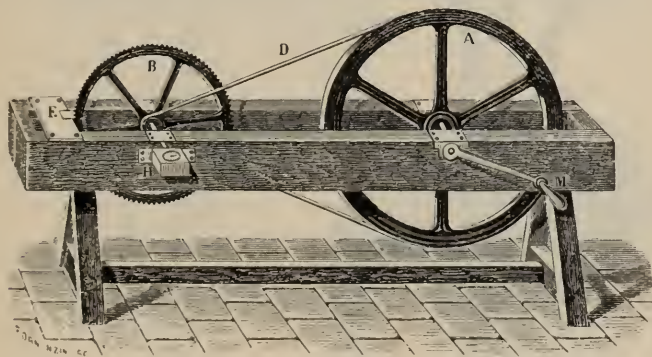

Fig. 232

When the wheel is moved slowly, the separate shocks against the card are distinctly heard; but if the velocity is gradually increased, the sound becomes higher and higher. Having obtained the sound whose number of vibrations is to be determined, the revolution of the wheel is continued with the same velocity for a certain number of seconds. The number of turns of the toothed wheel B is then read off on the indicator, and this multiplied by the number of teeth in the wheel gives the total number of vibrations. Dividing this by the corresponding number of seconds, the quotient gives the number of vibrations per second for the given sound.

242. **Siren.**—The *siren* is an apparatus which, like Savart's wheel, is used to measure the number of vibrations of a body in a given time. The name was given to it by its inventor, Cagniard Latour, because it yields sounds under water.

It is made entirely of brass. Fig. 233 represents it fixed on the table of a bellows, by which a continuous current of air can be sent through it. Figs. 234 and 235 show the internal details. The lower part consists of a cylindrical box, O, closed by a fixed plate, B. On this plate a vertical rod, T, rests, to which is fixed a disc, A, moving with the rod. In the plate B there are equidistant circular holes, and in the disc A an equal number of holes of the same size, and at the same distance from the centre as those of the plate. These holes are not perpendicular to the disc; they are all inclined to the same extent in the same direction in the plate, and are inclined to the same extent in the opposite direction in the disc, so that when they are opposite each other they have the appearance represented in *mn*, fig. 234. Consequently, when a current of air from the bellows reaches the hole *m*, it strikes obliquely against the sides of the hole *n*, and makes the disc A rotate in the direction *nA*.

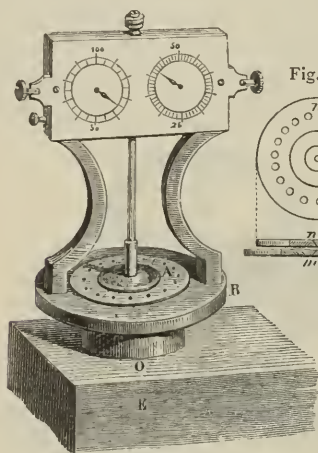

Fig. 233

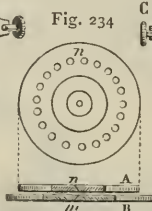

Fig. 234

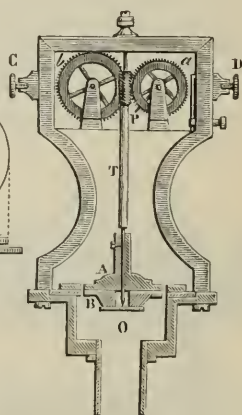

Fig. 235

For the sake of simplicity, let us first suppose that in the movable disc A there are eighteen holes, and in the fixed plate B only one, which faces one of the upper holes. The wind from the bellows striking against the sides of the latter, the movable disc begins to rotate, and the space between two of its consecutive holes closes the hole in the lower plate. But as the disc continues to turn from its acquired velocity, two holes are again opposite each other, a new impulse is produced, and so on. During a complete revolution of the disc the lower hole is eighteen times open and eighteen times closed. A series of puffs and stoppages is thus produced, which makes the air vibrate, and ultimately produces a sound when the successive impulses are sufficiently rapid. If the fixed plate, like the moving disc, had eighteen holes, each hole would separately produce the same effect as a separate one, the sound would be eighteen times as intense, but the number of vibrations would not be increased.

In order to know the number of vibrations corresponding to the sound produced, it is necessary to know the number of revolutions of the disc A in a second. For this purpose an endless screw on the rod T transmits the motion to a wheel, *a*, with 100 teeth. On this wheel, which moves by one tooth for every turn of the disc, there is a catch, P, which at each complete revolution moves one tooth of a second wheel, *b* (fig. 235). On the axis of these wheels there are two needles, which move round dials represented in fig. 233. One of these indices gives the number of turns of the disc A, the other the number of hundreds of turns. By means of two screws, D and C, the wheel *a* can be uncoupled from the endless screw.

Since the pitch of the sound rises in proportion to the velocity of the disc A, the wind is forced until the desired note is produced. The same current is kept up for a certain time—two minutes, for example—and the number of turns read off. This number, multiplied by 18 and divided by 120, gives the number of vibrations in a second. For the same velocity of rotation the siren gives the same sound in air as in water; the same is the case with all gases; and it appears, therefore, that any given sound depends on the number of vibrations produced, and not on the nature of the sounding body.

The buzzing and humming noise of certain insects is not vocal, but is produced by very rapid flapping of the wings against the air or the body. The siren has been ingeniously applied to count the rate per second of the vibrations thus produced, which is effected by bringing it into unison with the sound. It has in this way been found that the wings of a gnat flap at the rate of 1,500 times in a second. If a report is produced in a space with two parallel walls at no great distance apart, the sound is reflected from one to the other, and reaches the ear at regular and frequent intervals; that is, the repetition of the echo acts as a note.

A modification of the siren known as Brown's *steam-horn*, in which high-pressure steam is employed instead of compressed air, is used as a *fog-signal*. Its shrill and penetrating note is better adapted than an ordinary fog-horn, or even cannon, for being heard over the noise of breakers.

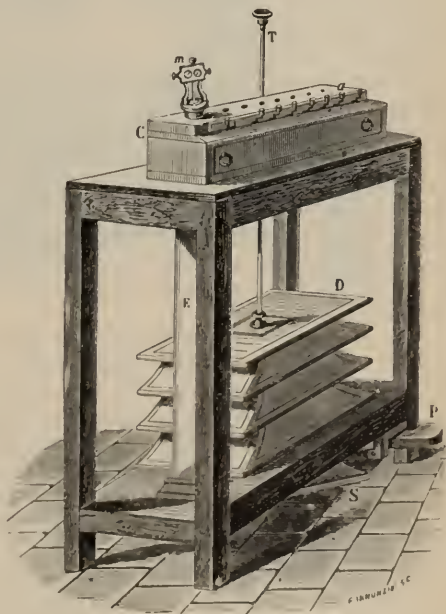

Fig. 236

243. **Bellows.**—In acoustics a *bellows* is an apparatus by which wind instruments, such as the siren and organ-pipes, are worked. Between the

four legs of a table there is a pair of bellows, S (fig. 236), which is worked by means of a pedal, P. D is a reservoir of flexible leather, in which is stored the air forced in by the bellows. If this reservoir is pressed by means of weights on a rod, T, moved by the hand, the air is driven through a pipe, E into a chest, C, fixed on the table. In this chest there are small holes closed by leather valves, which can be opened by pressing on keys in front of the box. The siren or sounding pipe is placed in one of these holes.

244. **Limit of perceptible sounds.**—Previous to Savart's researches, physicists assumed that the ear could not perceive a sound when the number of vibrations was below 16 for deep sounds, or above 9,000 for acute sounds. But he showed that these limits were too close, and that the faculty of perceiving sounds depends rather on their intensity than on their pitch; so that when extremely acute sounds are not heard it arises from the fact that they have not been produced with sufficient intensity to affect the organ of hearing.

By increasing the diameter of the toothed wheel, and consequently the amplitude and intensity of the vibrations, Savart pushed the upper limit of audibility to 24,000 vibrations in a second.

For deep sounds he substituted for the toothed wheel an iron bar about two feet long, which revolved on a horizontal axis between two thin wooden plates, about 0.08 of an inch from the bar. As often as the bar passed a grave sound was produced, due to the displacement of the air. As the motion was accelerated the sound became continuous, very grave, and deafening. By this means Savart found that, with 7 to 8 vibrations in a second, the ear perceived a distinct but very deep sound. Despretz, however, who investigated the same subject, disputed Savart's results as to the limits of deep sounds, and considers that no sound is audible that is made by less than 16 vibrations per second. Von Helmholtz held that the perception of a sound begins at 30 vibrations, and only has a definite musical value when the number is more than 40. Below 30 the impression of a number of separate beats is produced. On the other hand, acute sounds are audible up to those corresponding to 38,000 vibrations in a second. Such sounds, however, are far from pleasurable: they affect the ear as if it had been pricked with a pin or needle.

The discordant results obtained by these and other observers for the limit of audibility of higher notes are no doubt due to the circumstance that different observers have different capacities for the perception of sounds. Preyer has investigated this subject by means of experimental methods of greater precision than any that have hitherto been applied for this purpose. The minimum limit for the normal ear he found to lie between 16 and 24 single vibrations in a second; the maximum limit reached 41,000; but many persons with average powers of hearing were found to be absolutely deaf to notes of 16,000, 12,000, or even fewer vibrations.

It appears that the limit of audibility for any particular ear is increased with the strength of the sound. Paucher examined this by sounding a powerful siren by steam; he found that with steam of $\frac{1}{2}$ an atmosphere pressure the upper limit was at 48,000 vibrations, with $1\frac{1}{2}$ atmosphere it was 60,000, while with steam of $2\frac{1}{2}$ atmospheres it had not been attained with 72,000 vibrations.

245. **Duhamel's graphic method.**—When the siren or Savart's wheel is used to determine the exact number of vibrations corresponding to a given note, it is necessary to bring the sounds which they produce into unison with the given note, and this cannot be done exactly unless the experimenter has a practised ear. Duhamel's graphic method is very simple and exact, and free from this difficulty. It consists in fixing a fine point to the body emitting the note, and causing it to trace the vibrations on a properly prepared surface.

The apparatus consists of a wood or metal cylinder, A (fig. 237), fixed to a vertical axis, O, and turned by a handle. The lower part of the axis is a screw working in a fixed nut, so that according as the handle is turned from left to right, or from right to left, the cylinder is raised or depressed. Round

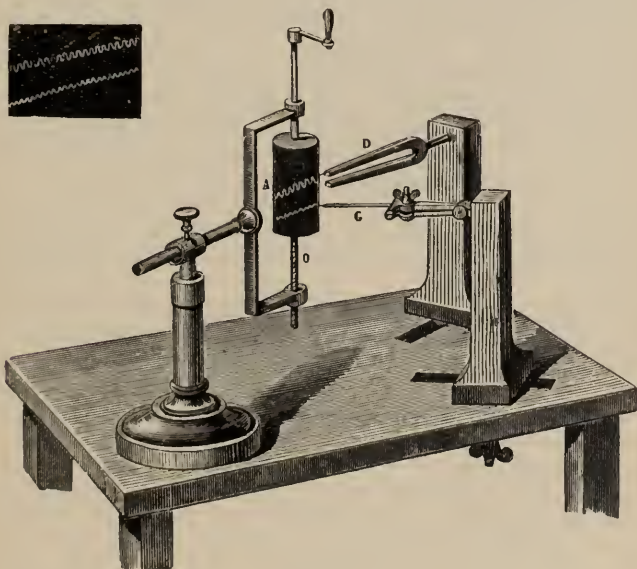

Fig. 237

the cylinder is rolled a sheet of paper covered with an inadhesive film of lampblack. On this film the vibrations register themselves. This is effected as follows. Suppose the body emitting the note to be a steel rod. It is held firmly at one end, and carries at the other a fine point which grazes the surfaces of the cylinder. If the rod is made to vibrate and the cylinder is at rest, the point would describe a short line; but if the cylinder is turned, the point produces an *undulating line*, containing as many undulations as the point has made vibrations. Consequently, the number of vibrations can be counted. It remains only to determine the time in which the vibrations were made.

There are several ways of doing this. The simplest is to compare the curve traced by the vibrating rod with that traced by a tuning-fork (251), which gives a known number of vibrations per second—for example, 500.

The prong of the fork is furnished with a point, which is placed in contact with the lampblack. The fork and the rod are then set vibrating together, and each produces its own undulating trace. When the paper is unrolled, it is easy, by counting the number of vibrations each has made in the same distance, to determine the number of vibrations made per second by the elastic rod. Suppose, for instance, that the tuning-fork made 150 vibrations, while the rod made 165 vibrations. Now we already know that the tuning-fork makes one vibration in the $\frac{1}{500}$ part of a second, and therefore 150 vibrations in $\frac{150}{500}$ of a second. But in the same time the rod makes 165 vibrations ; therefore, it makes one vibration in the $\frac{150}{500 \times 165}$ of a second, and hence it makes per second $\frac{500 \times 165}{150}$, or 550 vibrations.

CHAPTER III

THE PHYSICAL THEORY OF MUSIC

246. **Properties of musical notes.**—A simple musical note results from continuous rapid isochronous vibrations, provided the number of the vibrations falls within the very wide limits mentioned in the last chapter (244). Musical notes are in most cases compound. The distinction between a simple and a compound musical note will be explained later in the chapter. The tone yielded by a tuning-fork furnished with a proper resonance-box is *simple*; that yielded by a wide-stopped organ pipe, or by a flute, is *nearly simple*; that yielded by a musical string is *compound*.

Musical notes have three leading qualities, namely, *pitch*, *intensity* or *loudness*, and *timbre* or *quality*.

i. The *pitch* of a musical note is determined by the number of vibrations per second yielded by the body producing the note. It may be called the *vibration-frequency*.

ii. The *intensity* of the note depends on the *extent* of the vibrations. It is greater when the extent is greater, and less when it is less. It is, in fact, proportional to the square of the extent, or amplitude (56) of the vibrations which produce the note.

iii. The *timbre* or *quality* is that peculiar property of note which distinguishes a note when sounded on one instrument from the same note when sounded on another, and which by some is called the *colour*. Thus when the C of the treble staff is sounded on a violin and on a flute, the two notes will have the same pitch or vibration-frequency; and they may have the same intensity, and yet the two notes will have very distinct qualities; that is, their timbre is different. The cause of the peculiar timbre of notes will be considered later in the chapter.

247. **Musical intervals.**—Let us suppose that a musical note, which for the sake of future reference we will denote by the letter C, is produced by m vibrations per second; and let us further suppose that any other musical note, X, is produced by n vibrations per second, n being greater than m ; then the interval from the note C to the note X is the ratio $n : m$, the interval between two notes being obtained by *division*, not by *subtraction*. Although two or more notes may be separately musical, it by no means follows that when sounded together they produce a pleasant sensation. On the contrary, unless they are *concordant*, the result is harsh, and usually unpleasing. We have, therefore, to inquire what *notes* are fit to be sounded together. Now, when musical notes are compared, it is found that if they are separated by an interval of 2 : 1, 4 : 1, &c. they so closely resemble one another that they may for most purposes of music be considered as the same note. Thus

suppose c to stand for a musical note produced by $2m$ vibrations per second, then C and c so closely resemble each other as to be called in music by the same name. The interval from C to c is called an *octave*, and c is said to be an octave above C , and conversely C an octave below c . If we now consider musical sounds that do not differ by an octave, it is found that if we take three notes, X , Y , and Z , resulting respectively from p , q , and r vibrations per second, these three notes when sounded together will be concordant if the ratio of $p : q : r$ equals $4 : 5 : 6$. Three such notes form an *harmonic triad*, and if sounded with a fourth note, which is the octave of X , constitute what is called in music a *major chord*. Any of the notes of a chord may be altered by one or more octaves without changing its distinctive character; for instance, C , E , G , and c are a chord, and C , c , e , g form the same chord.

If, however, the ratio $p : q : r$ equals $10 : 12 : 15$, the three sounds are slightly dissonant, but not so much so as to disqualify them for producing a pleasing sensation. When these three notes and the octave to the lower are sounded together, they constitute what in music is called a *minor chord*.

248. **The musical scale.**—The series of sounds which connects a given note C with its octave c is called the *diatonic scale* or *gamut*. The notes composing it are indicated by the letters C, D, E, F, G, A, B . The scale is then continued by taking the octaves of these notes, namely, c, d, e, f, g, a, b , and again the octaves of these last, and so on.

The notes are also known by names, viz. *do* or *ut*, *re*, *mi*, *fa*, *sol*, *la*, *si*, *do*. The relations existing between the notes are these:— C, E, G form a major *triad*, G, B, d form a major *triad*, and F, A, c form a major *triad*. C, G , and F have, for this reason, special names, being called respectively the *tonic*, *dominant*, and *subdominant*, and the three triads the *tonic*, *dominant* and *subdominant* triads or chords respectively. Consequently, the numerical relations between the notes of the scale will be given by the three proportions—

$$\begin{aligned} C : E : G &:: 4 : 5 : 6 \\ G : B : d &:: 4 : 5 : 6 \\ F : A : c &:: 4 : 5 : 6 \end{aligned}$$

Hence, if m denotes the vibration-frequency corresponding to the note C , the frequency corresponding to the remaining notes will be given by the following table:—

<i>do</i>	<i>re</i>	<i>mi</i>	<i>fa</i>	<i>sol</i>	<i>la</i>	<i>si</i>	<i>do</i>
C	D	E	F	G	A	B	c
m	$\frac{9}{8}m$	$\frac{5}{4}m$	$\frac{4}{3}m$	$\frac{3}{2}m$	$\frac{5}{3}m$	$\frac{7}{5}m$	$2m$

The intervals between the successive notes being respectively—

C to D	D to E	E to F	F to G	G to A	A to B	B to c
$\frac{9}{8}$	$\frac{10}{9}$	$\frac{16}{15}$	$\frac{9}{8}$	$\frac{10}{9}$	$\frac{9}{8}$	$\frac{16}{15}$

It will be observed here that there are three kinds of intervals, $\frac{9}{8}$, $\frac{10}{9}$, and $\frac{16}{15}$; of these the first two are called a *tone*, the last a *semitone*, because it is about half as great as the interval of a tone. The two tones, however, are not identical, but differ by an interval of $\frac{9}{88}$, which is called a *comma*. Two

notes which differ by a *comma* can be readily distinguished by a trained ear. The interval between the tonic and any note is denominated by the position of the latter note in the scale ; thus the interval from C to G is a *fifth*. The scale we have now considered is called the *major* scale, as being formed of *major* triads. If the minor triad were substituted for the major, a scale would be formed that could be strictly called a *minor* scale. As scales are usually written, however, the *ascending* scale is so formed that the tonic bears a minor triad, the dominant and subdominant bear *major* triads, while in the *descending* scale they all bear *minor* triads. Practically, in musical composition, the dominant triad is always *major*. If the ratios given above are examined, it will be found that in the major scale the interval from C to E equals $\frac{5}{4}$, while in the minor scale it equals $\frac{6}{5}$. The former interval is called a *major* third, the latter a *minor* third. Hence the major third exceeds the minor third by an interval of $\frac{3}{20}$. This interval is called a *semitone*, though very different from the interval above called by that name.

249. **On semitones and on scales with different keynotes.**—It will be seen from the last article that the term ‘semitone’ does not denote a constant interval, being in one case equivalent to $\frac{1}{12}$ and in another to $\frac{2}{12}$. It is found convenient for the purposes of music to introduce notes intermediate to the seven notes of the gamut ; this is done by raising or lowering these notes by an interval of $\frac{1}{12}$. When a note (say C) is increased by this interval, it is said to be *sharpened*, and is denoted by the symbol C♯, called ‘C sharp’ ; that is, C♯ ÷ C = $\frac{12}{11}$. When it is lowered by the same interval, it is said to be *flattened*, and is represented thus—B♭, called ‘B flat’ ; that is, B ÷ B♭ = $\frac{12}{11}$. If the effect of this be examined, it will be found that the number of notes in the scale from C up to c has been increased from seven to twenty-one notes, all of which can be easily distinguished by the ear. Thus, reckoning C to equal 1, we have—

C	C♯	D♭	D	D♯	E♭	E	&c.
1	$\frac{12}{11}$	$\frac{11}{12}$	$\frac{12}{12}$	$\frac{13}{12}$	$\frac{11}{13}$	$\frac{12}{11}$	&c.

Hitherto we have made the note C the tonic or *keynote*. Any other of the twenty-one distinct notes above mentioned, e.g. G, or F, or C♯, &c., may be made the keynote, and a scale of notes constructed with reference to it. This will be found to give rise in each case to a series of notes, some of which are identical with those contained in the series of which C is the keynote, but most of them different. And of course the same would be true for the minor scale as well as for the major scale, and indeed for other scales which may be constructed by means of the fundamental triads.

250. **On musical temperament.**—The number of notes that arise from the construction of the scales described in the last article is so great as to prove quite unmanageable in the practice of music ; and particularly for music designed for instruments with fixed notes, such as the pianoforte or harp. Accordingly it becomes practically important to reduce the number of notes, which is done by slightly altering their just proportions. This process is called *temperament*, and the scale is called the *tempered scale*. By tempering the notes, however, more or less dissonance is introduced, and accordingly several different systems of temperament have been devised for rendering

this dissonance as slight as possible. The system usually adopted is called the system of *equal temperament*. It consists in retaining the octaves pure, and in substituting between C and *c* eleven notes at equal intervals, each interval being, of course, the twelfth root of 2, or 1.05946. By this means the distinction between the semitones is abolished, so that, for example, C# and D \flat become the same note. The scale of twelve notes thus formed is called the *chromatic scale*. It follows, of course, that major triads become slightly dissonant. Thus, in the diatonic scale, if we reckon C to be 1, E is denoted by 1.25000, and G by 1.50000. On the system of equal temperament, if C is denoted by 1, E is denoted by 1.25992 and G by 1.49831.

If individual intervals are made pure while the errors are distributed over the others, such a system is called that of *unequal temperament*. Of this class is *Kirnberger's*, in which nine of the tones are pure.

Although the system of equal temperament has the advantage of affording the greatest variety of tones with as small a number of notes as possible, yet it has the drawback that no chord of an equally tempered instrument, such as the piano, is perfectly pure. And as musical education mostly has its basis on the piano, even singers and instrumentalists usually give equally tempered intervals. Only in the case of string quartet players, who have freed themselves from school rules, and in that of vocal quartet singers, who sing frequently without accompaniment, does the natural pure temperament assert itself, and thus produce the highest musical effect.

251. **The number of vibrations producing each note. The tuning-fork.—**

Hitherto we have denoted the number of vibrations corresponding to the note C by *m*, and have not assigned any numerical value to that symbol. In the theory of music it is frequently assumed that the middle C corresponds to 256 double vibrations in a second. This is the note which, on a pianoforte of seven octaves, is produced by the white key on the left of the two black keys close to the centre of the keyboard. This number is convenient as being continually divisible by two, and is therefore frequently used in numerical illustrations. It is, however, arbitrary. An instrument is in tune provided the intervals between the notes are correct, when *c* is yielded by any number of vibrations per second not differing much from 256. Moreover, two instruments are in tune with each other if, being separately in tune, they have any one note, for instance C, yielded by the same number of vibrations. Consequently, if two instruments have one note in common, they can then be brought into tune jointly by having their remaining notes separately adjusted with reference to the

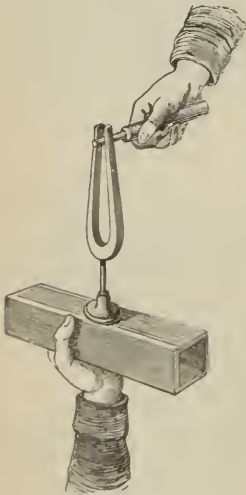

Fig. 238

fundamental note. A *tuning-fork* is an instrument yielding a constant sound, and is used as a standard for tuning musical instruments. It consists of an elastic steel rod, bent as represented in fig. 238. It is made

to vibrate either by drawing a bow across the ends, or by striking one of the legs against a small hammer covered with leather, or by rapidly separating the two prongs by means of a steel rod as shown in the figure. The vibration produces a note which is always the same for the same tuning-fork. The note is strengthened by fixing the tuning-fork on a box open at one end called a *sounding* or *resonance box*, adjusted so as to strengthen the special note of the tuning-fork. The vibrations of the air in the box produce the same note as the fork itself; the vibrations of the tuning-fork, being communicated to the column of air in the box, set it in vibration, and thus a note of considerable intensity is obtained.

The standard tuning-fork in any country represents its accepted concert pitch. It has been remarked for some years that not only has the pitch of the tuning-fork been getting higher in the large theatres of Europe, but also that it is not the same in London, Paris, Berlin, Vienna, Milan, &c. This is a source of great inconvenience both to composers and singers, and a commission was appointed in 1859 to establish in France a tuning-fork of uniform pitch, and to prepare a standard which would serve as an invariable type. In accordance with the recommendations of that body, a *normal tuning-fork* was established, which is compulsory on all musical establishments in France, and a standard has been deposited in the Conservatory of Music in Paris. It performs 437.5 double vibrations per second, and gives the standard note *a* or *la*, or the *a* in the treble stave (252). Consequently, with reference to this standard, the middle *c* or *do* would result from 262.5 double vibrations per second.

In England a committee, appointed by the Society of Arts, recommended that a standard tuning-fork should be one constructed to yield 528 double vibrations in a second, and that this should represent *c'* in the treble stave. This number has the advantage of being divisible by 2 down to 33, and is in fact the same as the normal tuning-fork adopted in Stuttgart in 1834, which makes 440 vibrations in the second, and, like the French one, corresponds to *a* in the same stave.

In exact determinations of pitch the temperature must be taken into account. Heat acts on the tuning-fork by expanding it, and also by diminishing the elasticity of the metal. Both effects concur in lowering the pitch. Thus König found that a tuning-fork which made 512 vibrations at 20° C. varied by 0.0572 for each degree Centigrade. Stone and McLeod found the number 0.055.

An international conference at Vienna in 1885 adopted a tuning-fork of polished mild cast-steel with prismatic prongs, making 435 vibrations in a second at 15° C., as the standard *a* note. This corresponds to 261 vibrations per second for the middle *c*.

252. **Musical notation. Musical range.**—It is convenient to have some means of at once naming any particular note in the whole range of musical sounds other than by stating its number of vibrations. Perhaps a convenient practice is to call the octave, of which the C is produced by a four-foot organ open pipe, by the capital letters C, D, E, F, G, A, B; the next higher octave by the corresponding small letters, *c, d, e, f, g, a, b*; and to designate the octaves higher than this by the index placed over the letter thus, *c', d', e', f', g', a', b'*, and the higher series in a similar manner. The

same principle may be applied to the notes below C ; thus the octave below C is $C_{,,}$, and the next lower one $C_{,,,}$.

Hence we have the series

$$C_{,,,} C_{,,} C c c' c'' c''' c^{iv}.$$

In musical writing the notes are expressed by signs which indicate the length of time during which the note is to be played or sung, and are written on a series of lines called a *stave*. Thus

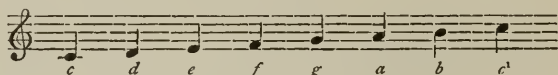

stands for the octave in the treble clef, of which the top note is the standard c' and the bottom is the middle c . When the five lines are insufficient they are continued above and below the staff by what are called *leger* lines. In order to avoid confusion, a bass clef is used for the lower notes ; and it

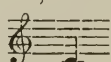
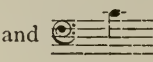
may be remarked that  and  stand for the same note (251), which is the middle c .

The deepest note of orchestral instruments is the $E_{,,,}$ of the double bass, which makes $41\frac{1}{4}$ vibrations, taking the keynote as making 440 vibrations in a second. Some organs and pianofortes go as low as $C_{,,,}$ with 33 vibrations in a second, some grand pianos even as low as $A_{,,,}$ with $27\frac{1}{2}$ vibrations. But the musical character of all these notes below $E_{,,,}$ is imperfect, for we are near the limit at which it is possible for the ear to combine the separate vibrations to a musical note (244). These notes can only be used musically with their next higher octave, to which they impart a certain character of depth and richness.

In the other direction, pianofortes go to a''' with 3520 or even c^{iv} with 4224 vibrations in a second. The highest note of the orchestra is probably the d^{iv} of the piccolo flute, which makes 4752 vibrations. Although the ear can distinguish sounds which are still higher, they have no longer a pleasurable character. And while the notes which are distinguishable by the ear range between 16 and 38,000 vibrations, or 11 octaves, those which are musically available range from about 40 to 4000 vibrations, or within 7 octaves.

253. **Amplitude of oscillation.**—The amplitude of oscillation which is required for the production of audible sounds is very small. Lord Rayleigh determined it in the case of the waves due to a pipe giving the note f^{iv} , which could be heard at a distance of 820 metres. He calculated that the amplitude of the oscillation of these waves could not be greater than 0.06 of a millimetre.

Töpler and Boltzmann were able to observe the sound of a stopped pipe making 181 vibrations, at a distance at which the amplitude of the vibrations could only be 0.04 cm., or about $\frac{1}{10}$ the wave-length of green light.

254. **On compound musical tones and harmonics.**—When any given note (say C) is sounded on most musical instruments, not that note alone is produced, but a series of other notes, of small and varying intensity. If C, which may be called the *primary* note, is denoted by unity, the

whole series is given by the numbers 1, 2, 3, 4, 5, 6, 7, &c. ; in other words, first the primary C is sounded, then its octave becomes audible, then the fifth to that octave, then the second octave, then the third, fifth, and a note between the sixth and seventh to the second octave, and so on. These secondary notes are called the *harmonics* of the primary note. Though feeble in comparison with the primary note, they may, with a little practice, be heard when the primary note is produced on most musical instruments ; when, for instance, one of the lower notes is sounded on the pianoforte.

255. **Consonance and resonance.**—A singular property of bodies in a state of vibration is that of setting in vibration bodies at rest. Thus, if two tuning-forks, tuned so as to give accurately the same note, are at some distance from each other, and one of them be sounded, the other will be set in vibration and emit the same note. But, if one of the forks is put slightly out of tune with the other, by attaching a piece of wax to one prong, for instance, then the excitation of either one will have no effect on the other.

It is remarkable that the successive action of a series of small mechanical impulses should, as in this case, be able to set a relatively very heavy body—such as a tuning-fork—in vibration ; but for this there are many purely mechanical analogies. Thus, if a series of pulls be exerted in regular intervals on the rope of a large church bell, the superposition of these small motions will ultimately set the bell swinging. A regiment of soldiers marching in step over an iron bridge at Angers set it in such powerful oscillation as to endanger its stability. In like manner, the position of a ship in the trough of the sea is very dangerous when the period of vibration of the waves coincides with that of its own vibration.

This phenomenon, that a body in a state of vibration has the power of causing an independent body at rest to vibrate in the same period, is called *consonance*.

If a metal wire freely suspended in the air is tightly stretched and then set in vibration, the note which it emits will be feeble, seeing that from its small surface it can set in vibration only small masses of air. So, too, a tuning-fork when sounded gives but a feeble note ; but if its stem is held on a table the note becomes far louder.

The reinforcement of a sound by attaching the sounding body to a large, dry, elastic wooden plate, called a sound-board, or to a wooden box enclosing a mass of air, is called *resonance* ; the vibrations of the sounding body are transmitted to the sound-board, which, being set in vibration, communicates its motion to large masses of air.

Although the terms consonance and resonance are sometimes used indiscriminately, there are distinctions between them.

Consonance is the excitation of an independent body to vibrate in unison with the sounding body ; it begins later than the sounding body, and continues after it has become silent. Resonance begins and ends with the sound of the exciting body. A sound-board strengthens and imparts a general sonority to a complex series of notes. The more a body diverges from the form of a plate and approaches that of a rod, the more is its resonance limited to strengthening one or two notes.

In resonance, however, there is a certain amount of tuning. For the loud and deep notes of the 'cello a large resonance-box is used, and a smaller

one for the higher notes of the violin. Small enclosed volumes of air also strengthen one note in preference.

256. **Von Helmholtz's analysis of sound.**—For the purpose of experimentally proving the presence of the harmonics as distinct tones, von Helmholtz devised an instrument which he called a *resonance-globe*. The use of this apparatus may be illustrated by the following experiment, which is analogous in principle with that described in article 276 :—If an empty glass cylinder is taken, and a vibrating tuning-fork is held over the mouth of the vessel, the air will not be set in vibration unless the cylinder is of a certain definite length ; such, indeed, that the wave-length of the fundamental note due to the air-vibrations in the cylinder corresponds to the wave-length of the note produced by the tuning-fork. Now, by pouring in water we can regulate the length of the column of air, and by trial can hit off the exact length ; when this is attained the note of the tuning-fork will be heard to be powerfully reinforced (276). A resonance-globe (fig. 239) is a glass or brass globe tuned to a particular note, furnished with two openings, one of which, *a*, is turned towards the origin of the sound, and the other, *b*, by means of an india-rubber tube, is applied to the ear. If the note proper to the resonance-globe exists among the harmonics of the compound note that is sounded,

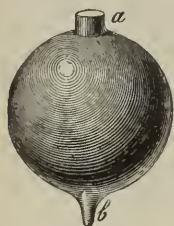

Fig. 239

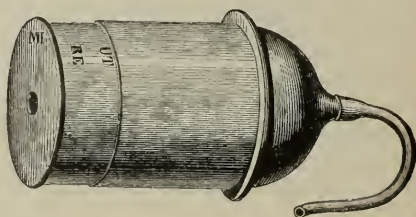

Fig. 240

it is strengthened by the globe, and thereby rendered distinctly audible. Further, other things being the same, the note proper to a given globe depends on the diameter of the globe and that of the uncovered opening. Consequently, by means of a series of such globes, the whole series of harmonics in a given compound tone can be rendered distinctly audible, and their existence put beyond a doubt.

König, the eminent acoustical-instrument maker, has made an important modification in the resonance-globe, to which he has given the form represented in fig. 240. The resonator is cylindrical, and the end which receives the sound can be drawn out, so that the volume may be increased at pleasure. As the sound thereby becomes deeper, the same resonator may be tuned to a variety of notes. On the tubulure fits an india-rubber tube by which the vibrations may be transmitted in any direction.

257. **König's apparatus for the analysis of sound.**—As the successive application to the ear of various resonators is both slow and tedious, König devised a remarkable apparatus in which a series of resonators act on manometric flames (290) ; the sounds thus, as it were, become visible, and may be shown to a large auditory.

It consists of an iron frame (fig. 241), on which are fixed in two parallel

lines fourteen resonators tuned so as to give the notes from *F*, to *c''*—that is to say three octaves and a half; or notes of which the highest give the lower harmonics of the primary. On the right is a chamber, *C*, which is supplied with coal gas by the india-rubber tube *D*, and on which are placed eight gas-jets, each provided with a manometric capsule (290). Each jet is connected with the chamber *C* by a special india-rubber tube, while behind the apparatus a second tube connects the same jet to one of the resonators. On the right of the jets is a system of rotating mirrors identical with that described in article 290.

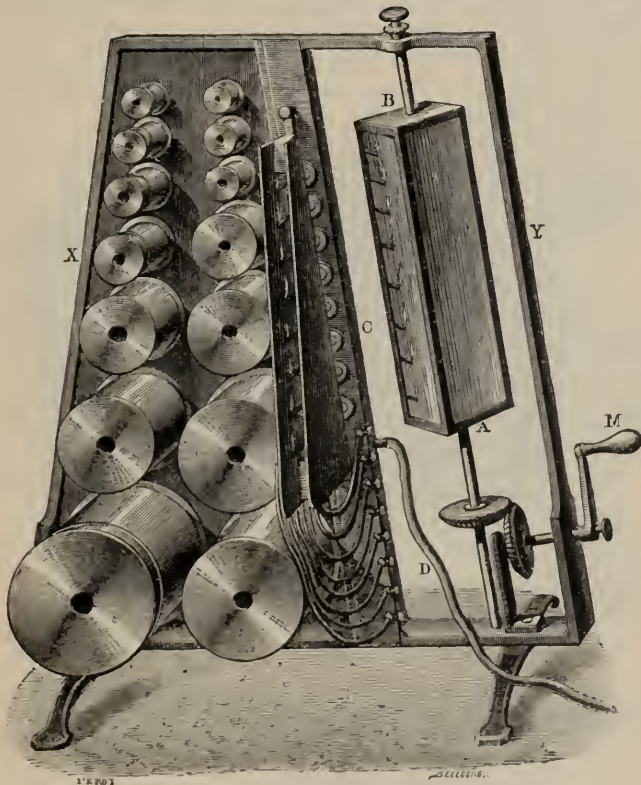

Fig. 241

These details being understood, suppose the largest resonator on the right tuned to resound with the note *1*, and seven others with the harmonics of this note. Let the sound *1* be produced in part of this apparatus; if it is simple, the lower resonator alone answers, and the corresponding flame is alone dentated; but if the fundamental note is accompanied by one or more of its harmonics, the corresponding resonators speak at the same time, which is recognised by the dentation of their flames; and thus the constituents of each sound may be detected.

258. **Synthesis of sounds.**—Not only did von Helmholtz succeed in decomposing sounds into their constituents; he also verified the result of his analysis by performing the reverse operation, the synthesis; that is, he reproduced a given sound by combining the individual sounds of which his resonators had shown that it was composed. The apparatus which he used for this purpose consists of eleven tuning-forks, the first of which yields the fundamental note of 256 vibrations, or C, nine others its harmonics, while the eleventh serves as make and break to cause the tuning-forks to vibrate by means of electro-magnets. Each tuning-fork has a special electro-magnet, and moreover a resonator, which strengthens it.

All these tuning-forks and their accessories are arranged in parallel lines of five (fig. 242), the first comprising the fundamental note and its uneven harmonics, 3, 5, 7, and 9; the second the even harmonics, 2, 4, 6, 8, and

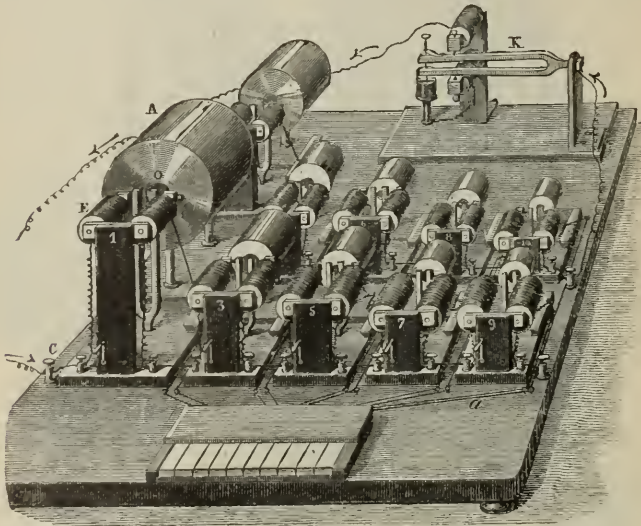

Fig. 242

10; beyond, there is the tuning-fork break, K, arranged horizontally. One of its prongs is provided with a platinum point which grazes the surface of mercury contained in a small cup, the bottom of which is connected by a copper wire with an electro-magnet placed in front of the fork.

The apparatus being thus arranged, a wire from a voltaic battery is connected with the binding-screw, *c*, and this with the electro-magnet, E; which in turn is connected with those of the nine following tuning-forks, and then with the fork, K, itself. So long as the latter does not vibrate the current does not pass, for the platinum point does not dip in the mercury cup which is connected with the other pole of the battery. But when the fork is made to vibrate by means of a bow, the current passes. Owing to their elasticity, the limbs of the tuning-fork soon revert to their original position, the point is no longer in the mercury, the current is broken, and so on at each double vibration of the fork. The intermittence of the current being

transmitted to all the other electro-magnets, they are alternately active and inactive. Hence they communicate to all the forks by their attraction the same number of vibrations. This is the case with the fork 1, which is tuned in unison with the fork break; but the fork 3, being tuned to make three times as many vibrations, makes three vibrations at each break of the current; that is to say, the electro-magnet only attracts it at every third vibration; in like manner, fork 5 only receives a fresh impulse every five vibrations, and so on.

The following is the working of the apparatus:—The resonator of each tuning-fork may be closed by a disc, O (fig. 243), so that the sound made by it is scarcely perceptible when the disc is lowered. Each disc is fixed to the end of a bent lever, the shorter arm of which is worked by a cord, *a*, which is connected with one of the keys of a keyboard placed in front of the apparatus (fig. 242). When a key is depressed, the cord moves the lever, which raises the clapper, and the resonator then acts by strengthening its fork. Hence by depressing a special key we may add to the fundamental sounds any of the nine primary harmonics, and thus reproduce the sounds the composition of which has been determined by analysis. For example, by depressing all the keys at once we obtain the sound of an open pipe in unison with the deepest tuning-fork. By depressing the key of the fundamental note and those of its uneven harmonics, we obtain the sound of a closed pipe.

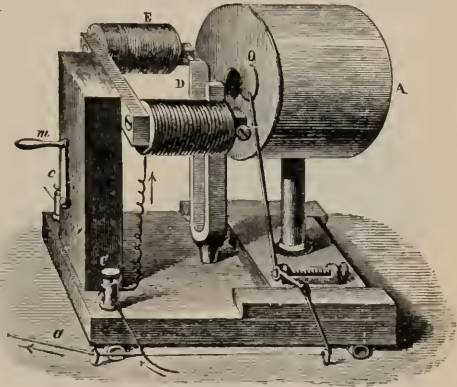

Fig. 243

259. **Results of von Helmholtz's researches.**—By both his analytical and synthetical investigations into sounds of the most varied kinds—those from various musical instruments, the human voice, and even noises—von Helmholtz fully succeeded in explaining the different *timbre* or quality of sounds. It is due to the different intensities of the harmonics which accompany the primary tones of these sounds. The leading results of these researches into the colour (246) of sounds may be thus stated:—

i. Simple sounds, as those produced by a tuning fork with a resonance-box, and by wide covered pipes, are soft and agreeable, without any roughness, but weak, and in the deeper notes dull.

ii. Musical sounds accompanied by a series of harmonics, say up to the sixth, in moderate strength, are full and rich. In comparison with simple tones they are grander and more sonorous. Such are the sounds of open organ-pipes, of the pianoforte, &c.

iii. If only the uneven harmonics are present, as in the case of narrow stopped pipes, of pianoforte strings struck in the middle, &c., the sound

becomes indistinct ; and, when a greater number of harmonics is audible, the sound acquires a nasal character.

iv. If the harmonics beyond the sixth and seventh are very distinct, the sound becomes sharp and rough. If less strong, the harmonics are not prejudicial to the musical usefulness of the notes. On the contrary, they are useful as imparting character and expression to the music. Of this kind are most stringed instruments, and most pipes furnished with tongues, &c. Sounds in which harmonics are particularly strong acquire thereby a peculiarly penetrating character ; such are those yielded by brass instruments.

260. **Production of vocal sounds.**—The *trachea* or *windpipe* is a tube which terminates at one end in the lungs, and at the other in the *larynx*, which is the true organ of vocal sound. Fig. 244 represents a horizontal section of this organ. It consists of a number of cartilaginous structures,

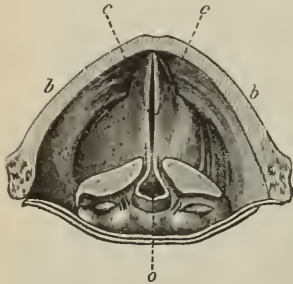

Fig. 244

bb, which are connected by various muscles, by which great variety and control in the motions are attainable. These muscles are connected with, and move, two elastic membranes or bands with broad bases fixed to the larynx, and with sharp edges, *cc* ; these are called the *vocal cords*. According to the pressure of the muscles, these cords are more or less tightly stretched, and the space between them, the *vocal slit*, is narrower or wider accordingly. In ordinary breathing, air passes through the triangular aperture *o* ; but when in singing this is closed, the vocal cords are stretched and are put in

vibration by the current of air, and produce tones which are higher the more tightly the cords are stretched and the narrower is the vocal slit. These changes can be effected with surprising rapidity, so that in this respect the human voice far exceeds anything that can be made artificially.

The notes produced by men are deeper than those of women or boys, because in them the larynx is longer and the vocal cords larger and thicker ; hence, though equally elastic, they vibrate less swiftly. The vocal cords are 18 millimetres long in men, and 12 millimetres long in women. Chest notes are due to the fact that the whole membrane vibrates, while the falsetto is produced by a vibration of the extreme edges only. The ordinary compass of the individual voice is within two octaves, though this is exceeded by some celebrated singers. Catalani, for instance, is said to have had a range of $3\frac{1}{2}$ octaves.

The wave-length of the sounds emitted by a man's voice in ordinary conversation is from 8 feet to 12 feet, and that of a woman's voice is from 2 feet to 4 feet.

The vowel sounds can be produced in any pitch, and the difference in them arises from the fact that to form a given vowel sound one or more characteristic notes, which are always the same, must be added. These change with the syllable pronounced, but depend neither on the height of the note nor on the person who emits them.

The form and cavity of the mouth can be greatly modified by the extent

to which it is opened, by the altered position of the tongue, and so forth. It thus forms a resonator which can be quickly and completely controlled. When the mouth is adjusted so as to produce the broad A, as in *father*, it has then a sort of funnel shape, with the wide part outward; for O, as in *more*, the effect is like that of a bottle with a wide neck; and for U, as in *poor*, it is that of a similar bottle with a narrow neck. For the other vowels, such as A, E, and I, the effect is as if the bottle were prolonged by a tube, formed by contracting the tongue against the palate.

If now, while the mouth is adjusted for the position in which it could utter the vowel U, different vibrating tuning-forks are successively held in front of it, only that emitting the note *f* will be found to be reinforced by the enclosed column of air vibrating in unison with it. This is accordingly the characteristic note of that vowel; in like manner, *b'* is the note for O, and *b''* that for A. The other vowel sounds, such as I, have a higher and lower characteristic note; thus those of A, as in *day*, are *d* and *d'''*, of I, *f* and *d^{iv}*. In most cases, however, the deeper notes have but little influence.

261. Perception of sounds. The ear.—The organ of hearing in man consists of several structures; there is first the outer ear (fig. 245) by which the sound is collected and

transmitted through the auditory passage, *a*, to the *drum* or *tympanum*, *t*. This is a delicate tightly stretched membrane or skin which separates the outer ear from the middle ear or *tympanic cavity*, which is a cavity in the temporal bone in which are several small bones whose dimensions are considerably exaggerated in the figure. One of these, the *hammer*, *d*, is attached at one end to the

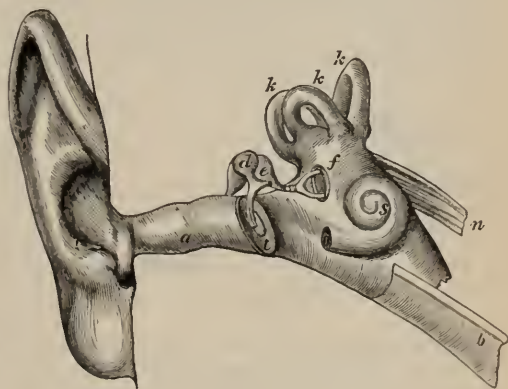

Fig. 245

drum, and at the other is jointed to the *anvil*, *e*; the latter is connected by means of the *stirrup* bone, *f*, to the *oval window*, an aperture closed by a fine membrane, which separates the tympanic cavity from the *labyrinth*. The tympanic cavity is also connected by the *Eustachian tube*, *b*, with the cavity of the mouth, so that the air in it is always under the same pressure.

The labyrinth is a complicated structure filled with fluid; it is entirely of bone, with the exception of the oval window already mentioned and the *round window*, *o*. The labyrinth consists of three parts: the *vestibule*, which is closed by the oval window; the three *semicircular canals*, *k*; and the spiral-shaped *cochlea*, or snail shell, *s*. This is separated throughout its entire length by a division partly of bony projection and partly of membrane; the upper part of this division is connected with the vestibule, and therefore with the oval window while the lower part is connected with the round

window. In the labyrinthine fluid of this part the termination of the auditory nerve is spread, the other end leading to the brain.

The membranous part of this diaphragm is lined with about 3000 extremely minute fibres, which are the terminations of the acoustic nerve, *n*. Each of these, which are called *Corti's fibres*, seems to be tuned for a particular note as if it were a small resonator. Thus when the vibrations of any particular note reach these fibres, through the intervention of the stirrup bone and the fluid of the labyrinth, one fibre or set of fibres only vibrates in unison with this note, and is deaf for all others. Hence each simple note causes only one fibre to vibrate, while compound notes cause several; just as when we sing with a piano only the fundamental note and its harmonics vibrate. Thus, however complex external sounds may be, these microscopic fibres can analyse them and reveal the constituents of which they are formed.

262. **Interference of sound.**—If two waves of sound of the same length proceed in the same direction, and if they coincide in their phases and the amplitudes of vibration are the same, they strengthen each other; if, however, their phases differ by half a wave-length they neutralise each other, and silence is the result. This is called the *interference of sound*.

It may be illustrated by a number of experiments, of which that represented in fig. 246 is one of the simplest and most convenient. Two glass tubes, *obac* and *nedf*, are connected at one end by a short india-rubber tube *ad*, while at the other end they are connected by a long india-rubber tube, *cgf*.

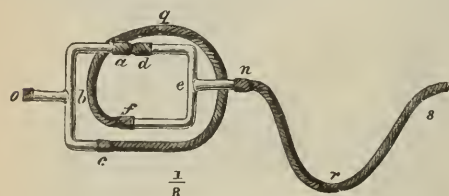

Fig. 246

The end *o* is held in one ear, the other ear being closed, and a tuning-fork is sounded in front of the long free tube, *nrs*. If the length of the india-rubber tube *cgf* be half the wave-length of the note produced by the fork, the sounds will reach the ear in

completely opposite phases; they will accordingly neutralise each other and no sound will be heard. But if this india-rubber tube is closed by pinching it, the note is at once heard. If the tuning-fork gives the note *c'*, the note it produces makes 528 vibrations in a second, and the length of the tube should be 34 centimetres.

263. **Beats.**—If the notes are of the same kind and slightly different in pitch—for instance, if they are produced by two tuning-forks not quite in tune—they alternately weaken and strengthen each other; they are said to *beat* with one another. This may be explained as follows:—Suppose one fork to make 256 and the other 255 vibrations per second, and let them be sounded so as to have the same loudness. If at the beginning of a second their phases coincide so that at any particular place—the ear of the observer—condensation due to one coincides with condensation due to the other, the sound will be of double loudness. At the end of half a second the first will have made 128 and the other $127\frac{1}{2}$ complete vibrations, so that condensation will now coincide with rarefaction and there will be practically no sound. When one second is completed they will again agree in phase, and the sound

is augmented, and so on. Thus the sound will rise and fall, there being one alternation or one beat per second. In the same way it is seen that if the frequency of the second fork is 254, there will be two beats per second. The effect of the beating of notes on the ear, as compared with that of a continuous note, is strictly analogous to the effect produced on the eye by a flickering, as compared with a steady, light.

It may be proved that when two simple notes are produced by m and n vibrations per second, they produce $m - n$ beats per second; thus, if C is produced by 128, and D by 144, vibrations per second, on being sounded together they will produce 16 beats per second. It has been ascertained that the beats produced by two notes are not audible unless the ratio $m : n$ is less than the ratio 6 : 5. Hence, in this case, though the alternations of intensity exist, they would not be audible. Also, if the notes have any different intensities, the intensity of the beat is very much disguised.

It is found that when beats are fewer than 10 per second or more than 70 per second they are disagreeable, but not to the extent of producing discord. Beats from 10 to 70 per second may be regarded as the source of all discord in music, the maximum of dissonance being attained when about 30 beats are produced in a second. For example, if c and B are sounded together the effect is very discordant, the interval between those notes being 16 : 15, so that the beats are audible, and the number of beats per second being 16, since the upper note has a vibration-frequency of 256. On the other hand, if C, E, and G are sounded together there is no dissonance; but if C, E, G, B are sounded together the discord is very marked, since C produces c , which is discordant with B. It will be noticed that C, E, G is a major triad, while E, G, B is a minor triad.

A compound musical note, being composed of simple notes whose frequencies are as the numbers 1, 2, 3, 4, 5, 6, 7, &c., does not give rise to any simple notes capable of producing an audible beat up to the seventh—the sixth and seventh are the first that produce an audible beat. It is for this reason that there is no trace of roughness in a compound note, unless the seventh harmonic be audible.

If we were to represent graphically a compound note, we should proceed to construct a curve out of simple notes of different intensities by drawing the curves corresponding to each of the components, and then finding the ordinates of the compound curve by adding algebraically the ordinates of the simple curves. It is evident that the resulting curve will take different *forms* according to the presence or absence of different harmonics and to their different intensities; in other words, the quality or timbre of the notes produced by different instruments will depend upon the *form* of the curve representing vibrations producing the sound.

Beats not too fast to be readily counted arise between adjacent notes in the lower octaves of large organs. They are also met with in the sounds of church bells, and in those emitted by telegraph wires when vibrating powerfully in a strong wind. They are heard very distinctly in the latter case by pressing one ear against a telegraph post and closing the other.

By means of beats, the notes emitted by two musical instruments may be brought into very accurate unison, by continuing the tuning until the beats disappear. In order to make tuning-forks produce the normal number of

440 vibrations, an auxiliary tuning-fork is used which makes 436 vibrations ; each of the forks under experiment must then make with this 4 beats in a second, which can be controlled with very great accuracy.

264. **Combinational notes.**—Besides the beats produced when two musical notes are sounded together, there is another and distinct phenomenon, which may be thus described :—Suppose two simple notes to be simultaneously produced by n and m vibrations per second. It has been shown by von Helmholtz that they generate a series of other notes. The principal one of these, which may be called the *differential note*, is produced by $n - m$ vibrations per second. Its intensity is usually very small, but it is distinctly audible in beats. It has been called the *grave harmonic*, as its pitch is generally much lower than that of the notes by which it is generated. It has been supposed to be caused by the beats becoming too numerous to be distinguished, and coalescing into a continuous sound, and this supposition was countenanced by the fact that its pitch is the same as the beat number. The supposition is shown to be erroneous, first by the existence of the differential tones for intervals that do not beat ; and, secondly, by the fact that, under certain circumstances, both the beats and the differential tones may be heard together.

265. **The physical constitution of musical chords.**—Let us suppose two compound notes to be sounded together, say C and G ; then we obtain two series of notes each consisting of a primary and its harmonics—namely, denoting C by 4, the two series, 4, 8, 12, 16 . . . and 6, 12, 18, 24, &c. Now, if, instead of producing the two notes C and G, we had sounded the octave below C, we should have produced the series, 2, 4, 6, 8, 10, 12, 14, 16, 18, &c. It is plain that the two former series when joined differ from the last in the following respects :—(a) The primary note 2 is omitted. (b) In the case of the last series, the consecutive notes continually decrease in intensity : whereas in the two former series, 4 and 6 are of the same intensity, 8 is of lower intensity, but the two 12's will strengthen each other, and so on. (c) Certain of the harmonics of the primary 2 are omitted ; for example, 10, 14, &c., do not occur in either of the two former series. In spite of these differences, however, the two compound notes affect the ear in a manner very closely resembling a single compound note ; in short, they coalesce into a single note with an artificial colour. It may be added that in the case above taken C and G produce as a combination note 2 (that is, 6 - 4) ; so that, strictly speaking, the 2 is not wanted in the series produced by C and G, only it exists in very diminished intensity. The same explanation will apply to all possible chords ; for example, in the case of the major chord, C, E, G, we have a note of artificial colour expressed by the series of simple tones 4, 5, 6, 8, 10, 12, 15, 16, 18, &c., together with the combination notes, 1, 1, 2. It will be remarked that in the whole of these series there are no dissonant notes introduced, except 15, 16, and 16, 18, and this dissonance will be inappreciably slight, since 15 is the third harmonic of 5, and 16 the fourth harmonic of 4, so that their intensities will be different, as also will be the intensities of 16 and 18. On the other hand, nearly all the notes which form a *natural* compound note are present—namely, there are 1, 2, 4, 5, 6, 8, 10, 12, &c., in place of 1, 2, 3, 4, 5, 6, 7, 8, 9, 10, 11, 12, &c. In short, the major triad differs only from a *natural* compound note in that it consists of

a series of simple notes of different intensities, and omits those which, by beating with the neighbouring note, would produce dissonance ; for example, 7, which would beat with 6 and 8 ; 9, which would beat with 8 and 10 ; and 11, which would beat with 10 and 12. It is this circumstance which renders the major chord of such great importance in harmony. If the constituents of the minor chord are similarly discussed—namely, three compound tones whose primaries are proportional to 10, 12, 15—it will be found to differ from the major chord in the following principal respects :—(a) The primary of the natural tone to which it approximates is very much deeper than that of the corresponding major chord. (b) It introduces the *differential* notes, 2, 3, 5, which form a major chord. Now it has already been remarked that when a major and minor chord are sounded together they are distinctly dissonant ; for example, when C, E, G, A are sounded together. Accordingly, the fact of the differential notes forming a major chord shows that an elementary dissonance exists in every minor chord.

CHAPTER IV

VIBRATIONS OF STRETCHED STRINGS AND OF COLUMNS OF AIR

266. **Vibrations of strings.**—By a *string* is meant the string of a musical instrument, such as a violin, which is stretched by a certain force, and is commonly of catgut, or is a metal wire. The vibrations which strings experience may be either *transverse* or *longitudinal*; but practically the former are alone important. *Transverse vibrations* may be produced by drawing a bow across the string, as in the case of the violin; or by striking the string, as in the case of the pianoforte; or by twitching it transversely, and then letting it go suddenly, as in the case of the guitar and harp.

267. **Sonometer.**—The *sonometer*, also called the monochord, is an apparatus by which the transverse vibrations of strings may be investigated.

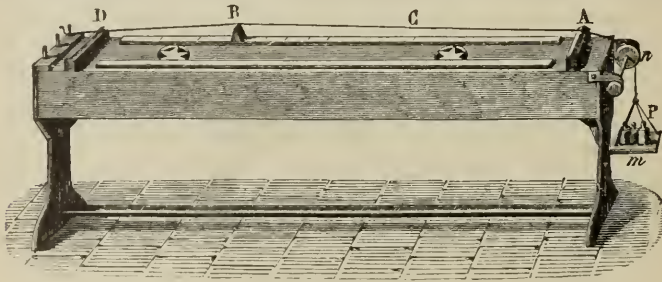

Fig. 247

It consists of a box of thin wood—which acts as a resonator and has the effect of greatly strengthening the sound—on which are two fixed bridges A and D (fig. 247), over which and over the pulley *n* passes the string C, which is usually a metal wire. This is fastened at one end, and stretched at the other by weights, P, which can be increased at will. By means of a third movable bridge, B, the length of that portion of the wire which is to be put in vibration can be altered at pleasure.

268. **Laws of the transverse vibration of strings.**—The velocity with which a pulse travels along a stretched string is directly proportional to the square root of the elasticity and inversely proportional to the square root of the density. Thus, if *v* is the velocity, *e* the elasticity, and *d* the density (mass per unit volume), $v = \sqrt{e/d}$. When the vibrations of the string are transverse, $e = P/\pi r^2$; that is, *e* is equal to the stretching force in dynes per unit of cross section of the wire. Thus $v = \sqrt{\frac{P}{\pi r^2 d}}$. If the string is vibrating

as a whole—that is, forms a single loop between its two fixed extremities—the wave-length corresponding to the note it produces is twice the length of the string, or, $\lambda = 2l$, where λ is the wave-length and l the length of the string; and if n = the number of vibrations produced per second, $v = \lambda n = 2ln$ (226).

Thus we arrive at the formula $n = v/2l = \frac{1}{2rl} \sqrt{\frac{P}{\pi d}}$, which may be written

$n = \frac{1}{2l} \sqrt{\frac{P}{m}}$, m being the mass of the string per unit length. Of course, if P , the stretching force, is expressed in gravitational instead of in absolute measure, we must write Pg instead of P , g being the acceleration due to gravity.

This formula expresses the following laws :—

I. *The stretching weight or tension being constant, the number of vibrations in a second is inversely as the length.*

II. *The number of vibrations in a second is inversely as the diameter of the string.*

III. *The number of vibrations in a second is directly as the square root of the stretching weight or tension.*

IV. *The number of vibrations in a second is inversely as the square root of the density of the material.*

V. *By combining II. and IV. the number of vibrations is inversely as the square root of the mass of the string per unit length.*

These laws are applied in the construction of stringed instruments, in which the length, diameter, tension, and material of the strings are so chosen that given notes may be produced from them.

269. **Experimental verification of the laws of the transverse vibration of strings.**—*Law of the lengths.*—In order to prove this law, we may call to mind that the relative numbers of vibrations of the notes of the gamut are

C	D	E	F	G	A	B	C
1	$\frac{9}{8}$	$\frac{5}{4}$	$\frac{4}{3}$	$\frac{3}{2}$	$\frac{5}{3}$	$\frac{15}{8}$	2

If now the entire length of the sonometer wire is made to vibrate, and then, by means of the bridge B, the lengths $\frac{6}{5}$, $\frac{4}{5}$, $\frac{3}{4}$, $\frac{2}{3}$, $\frac{3}{5}$, $\frac{4}{5}$, $\frac{1}{2}$, which are the inverse of the above numbers, are successively made to vibrate, all the notes of the gamut are successively obtained, which proves the first law.

Law of the diameters.—This law is verified by stretching upon the sonometer, by equal stretching forces, two cords of the same material, the diameters of which are as 3 to 2, for instance. When these are made to vibrate, the second cord gives the *fifth* above the other; which shows that it makes three vibrations while the first makes two.

Law of the tensions.—Having placed on the sonometer two identical strings, they are stretched by weights which are as 4 : 9. The second now gives the *fifth* above the first, from which it is concluded that the numbers of their vibrations are as 2 : 3; that is, as the square roots of the tensions. If the two weights are as 16 to 25, the major third or $\frac{4}{3}$ would be obtained.

Law of the densities.—Two strings of the same radius, but different densities, are fixed on the sonometer. Having been subjected to equal stretching weights, the position of the movable bridge on the denser one is

altered until it is in unison with the other string. If then d and d' are the densities of the two strings, and l and l' the lengths which vibrate in unison,

we find $\frac{l}{l'} = \frac{\sqrt{d}}{\sqrt{d'}}$. But as we know from the first law that $\frac{l}{l'} = \frac{n'}{n}$, we have

$\frac{n}{n'} = \frac{\sqrt{d'}}{\sqrt{d}}$, which verifies this law. Thus, if a copper wire whose density is 9,

and a catgut string of the density 1, are of equal length and diameter, and are stretched by the same weight, the vibrations of the copper wire will be one-third as rapid as those of the string.

In order to obtain deeper notes the bass strings of pianofortes are wound transversely with thin wire, by which d is increased.

The laws of vibrating strings presuppose that they are long, flexible, and tightly stretched; but if they are short, stout, and but little stretched, the *rigidity* of the string comes into play, and the number of vibrations they make is higher than the theoretical number; the effect of the rigidity is the same as if a constant weight were added to the stretching weight.

270. **Nodes and loops.**—Let us suppose the string AD (fig. 247) to begin vibrating, the ends A and D being fixed, and, while it is doing so, let a point B be brought to rest by a stop, and let us suppose DB to be one-third part of AD. The part DB must now vibrate about B and D as fixed points in the manner indicated by the continuous and dotted lines (fig. 248); now all parts of the same string tend to make a vibration in the same time; accordingly, the part between A and B will not perform a single vibration, but will divide into two at the point C, and vibrate in the manner shown in the figure. If BD were one-fourth part of AD (fig. 249), the part AB would be subdivided at C and C' into three vibrating portions each equal to BD. The points B, C, C' are called *nodes* or *nodal points*; the part of the string between

Fig. 248

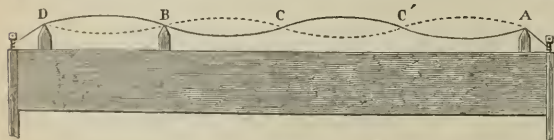
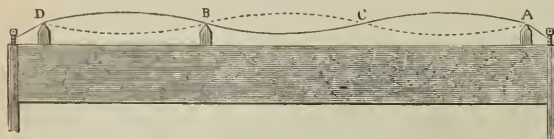

Fig. 249

any two consecutive nodes is called a *loop* or *ventral segment*. The middle point of a loop is frequently called an *antinode*.

It will be remarked that the ratio of BD : BA must be that of some two whole numbers; for example, 1 : 2, 1 : 3, 2 : 3, &c.; other-

wise the nodes cannot be formed, since the two portions of the string cannot then be made to vibrate at the same time, and the vibrations will interfere with and soon destroy one another.

If now we refer to fig. 248, the existence of the node at C can be easily proved by bending some light pieces of paper and placing them as riders on the string—say three pieces, one at C and the others respectively midway between B and C and between C and A. When the string is bowed or plucked between D and B, the rider at C experiences only a very slight

motion, and remains in its place, thereby proving the existence of a node at C; the other two are violently shaken, and in most cases thrown off the string.

When a musical string vibrates between fixed points, A and B, its motion is not quite so simple as might be inferred from the above description. In point of fact, partial vibrations are soon produced, and superimposed upon the primary ones. The partial vibrations correspond to the half, third, fourth, &c. parts of the string. It is by these partial vibrations that the harmonics are produced which accompany the fundamental note due to the primary vibrations; they are usually, however, so feeble as to be imperceptible to ordinary ears.

271. Wind instruments.—In the cases hitherto considered, the sound results from the vibrations of solid bodies, and the air only serves as a vehicle for transmitting them. In wind instruments, on the contrary, when the sides of the tube are of adequate thickness, the enclosed column of air is the sounding body. In fact, the substance of the tubes is without influence on the fundamental note; with equal dimensions, it is the same whether the tubes are of glass, of wood, or of metal. These different materials simply do no more than give rise to different harmonics, and thereby impart a different quality to the compound tone produced.

In reference to the manner in which the air in tubes is made to vibrate, wind instruments are divided into *mouth* instruments and *reed* instruments.

272. Mouth instruments.—In mouth instruments all parts of the mouth-piece are fixed. Fig. 251 represents the mouthpiece of an organ pipe, and fig. 250 that of a whistle, or of a flageolet. In both figures, the aperture *ib* is called the mouth; it is here that air enters the pipe; *b* and *o* are the *lips*, the upper one of which is bevelled. The mouth-piece is fixed at one end of a tube, the other end of which may be either opened or closed. In fig. 251 the tube can be fitted on a wind-chest by means of the foot P.

When a rapid current of air enters by the mouth, it strikes against the upper lip, and a shock is produced which causes the air to issue from *bo* in an intermittent manner. In this way pulsations are produced which, transmitted to the air in the pipe, make it vibrate, and a sound is the result. In order that a pure note may be produced, there must be a certain relation between the form of the lips and the magnitude of the mouth; the tube also ought to have a great length in comparison with its diameter. The number of vibrations depends in general on the dimensions of the pipe and the velocity of the current of air.

273. Reed instruments.—In reed instruments a simple elastic tongue sets the air in vibration. The tongue, which is either of metal or of wood, is moved by a current of air. The mouthpieces of the oboe, the bassoon, the clarinet, the child's trumpet, are different applications of the reed, which, it may be remarked, is seen in its simplest form in the Jew's-harp. Some organ pipes are reed pipes, others are mouth pipes.

Fig. 252 represents a model of a reed pipe as commonly shown in

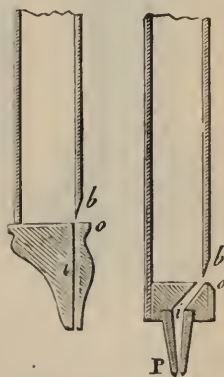

Fig. 250

Fig. 251

lectures. It is fixed on the wind-chest Q of a bellows, and the vibrations of the reed can be seen through a glass plate, E, fitting into the sides. A wooden horn, H, strengthens the sound.

Fig. 253 shows the reed out of the pipe. It consists of four pieces: 1st, a rectangular wooden tube closed below and open above at *o*; 2nd, a copper plate, *cc*, forming one side of the tube, in which there is a longitudinal aperture, through which air passes from the tube MN to the orifice *o*; 3rd, a thin elastic plate, *i*, called the *tongue*, which is fixed at its upper end, and which grazes the edge of the longitudinal aperture, nearly closing it; 4th, a curved wire, *r*, which presses against the tongue, and can be moved up and down. It thus regulates the length of the tongue and determines the pitch

of the note. It is by this wire that reed pipes are tuned. The reed being replaced in the pipe MN, when a current of air enters by the foot P, the tongue is compressed, it bends inwards and affords a passage to air, which escapes by the orifice *o*. But, being elastic, the tongue regains its original position, and performing a series of oscillations, successively opens and closes the orifice. In this way sound-waves result and produce a note whose pitch depends upon the dimensions and elasticity of the tongue.

In this reed the tongue vibrates alternately before and behind the aperture, and just escapes grazing the edges, as is seen in the harmonium, concertina, &c.; such a reed is called a *free reed*. But there are other reeds, called *beating*

or *striking reeds*, in which the tongue, which is larger than the orifice, strikes against the edges at each oscillation, closing it like a flap. The reed of the clarinet, represented in fig. 254, is an example of this; it is kept in its place by the pressure of the lips. The reeds of the oboe and bassoon are also of this kind.

274. **Of the notes produced by the same pipe.**—Daniel Bernoulli discovered that the same organ pipe can be made to yield a succession of notes by properly varying the force of the current of air. The results he arrived at may be thus stated:—

i. If the pipe is open at the end opposite to the mouthpiece, then, denoting the fundamental note by 1, we can, by gradually increasing the force of the current of air obtain successively the notes 2, 3, 4, 5, &c.; that is to say, all the *harmonics* of the primary note.

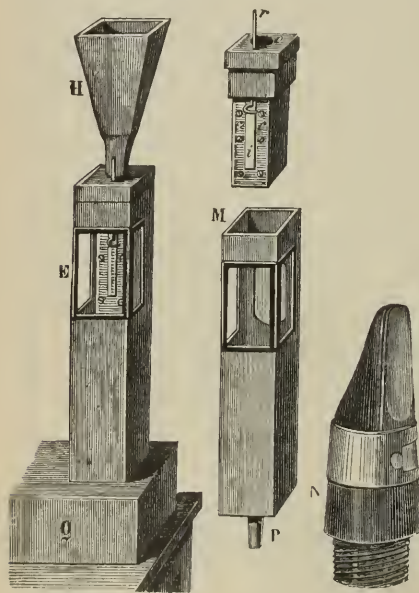

Fig. 252

Fig. 253

Fig. 254

ii. If the pipe is closed at the end opposite to the mouthpiece, then, denoting the fundamental note by 1, we can, by gradually increasing the force of the current of air, obtain successively the notes 3, 5, 7, &c. ; that is to say, only the uneven *harmonics* of the primary note.

A closed and an open pipe yield the same fundamental note if the closed pipe is half the length of the open pipe, and if in other respects they are the same ; or, what is an equivalent statement, with a closed and an open pipe of the same length the former gives a note an octave lower than the latter.

In any case, it is impossible to produce from the given pipe a note not included in the above series respectively.

Although the above laws are enunciated with reference to an organ pipe, they are true of any other pipe of uniform section.

275. **On the nodes and loops of an organ pipe.**—The vibrations of the air producing a musical note take place in a direction parallel to the axis

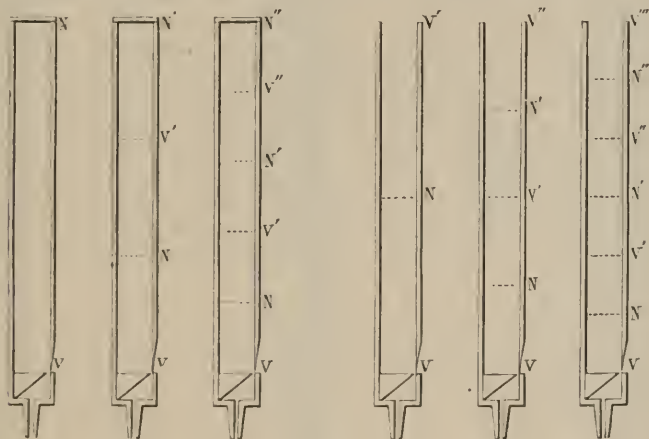

Fig. 255 Fig. 256 Fig. 257 Fig. 258 Fig. 259 Fig. 260

of the pipe—not transversely, as in the case of the portions of a vibrating string. In the former case, however, as well as in the latter, the phenomena of *nodes* and *loops* may be produced. But now by a *node* must be understood a section of the column of air contained in the pipe, where the particles remain at rest, but where there are rapid alternations of *condensation* and *rarefaction*. By the middle of a *loop* or *ventral segment* (antinode) must be understood a section of the column of air contained in the pipe, where the vibrations of the particles of air have the greatest amplitudes, and where there is no change of density. The sections of the column of air are, of course, made at right angles to its axis. When the column of air is divided into several vibrating proportions, it is found that the distance between any two consecutive loops is constant, and that it is bisected by a node. We can now consider separately the cases of the open and closed pipes.

i. In the case of a stopped pipe, the top is always a node, for the layer of air in contact with it is necessarily at rest, and only undergoes variations

in density. At the mouthpiece, on the contrary, where the air has a constant density (that of the atmosphere), and the vibration is at its maximum, there is always an antinode. When there is one node and one loop (fig. 255) the pipe yields its fundamental note, and the distance VN from the antinode to the node is equal to one-quarter of a wave-length.

If the current of air is forced, while the mouthpiece always remains an antinode, and the top a node, the column divides into three equal parts (fig. 256), and an intermediate node and loop are formed. The sound produced is the first harmonic. When the second harmonic is produced, there are two intermediate nodes and two loops, and the tube is then subdivided into five equal parts (fig. 257), and so on.

ii. In the case of the open pipe, whatever note it produces, there must be an antinode at each end, since the enclosed column of air is in contact with the external air at those points. When the primary note is produced, there will be an antinode at each end, and a node at the middle section of the pipe, the column being divided into *two* equal parts (fig. 258). When the first harmonic is produced, there will be an antinode at each end, and a loop in the middle, the column being divided into *four* equal parts by the alternate nodes and antinodes (fig. 259). When the second harmonic is produced, the column of air will be divided into *six* equal parts by the alternate nodes and loops, and so on (fig. 260). It will be remarked that the successive modes of division of the vibrating column are the only ones compatible with the alternate recurrence at equal intervals of nodes and loops, and with the occurrence of an antinode at each end of the pipe.

There are several experiments by which the existence of nodes and loops can be shown.

(a) If a fine membrane is stretched over a pasteboard ring, and has sprinkled on it some fine sand, it can be gradually let down a tube, as shown in fig. 263. Now, suppose the tube to be producing a musical note. As the membrane descends, it will be set in vibration by the vibrating air. But when it reaches a node it will cease to vibrate, for there the air is at rest. Consequently, the grains of sand, too, will be at rest, and their quiescence will indicate the position of the node. On the other hand, when the membrane reaches the middle point of a loop—that is, a point where the amplitude of the vibrations of the air attains a maximum—it will be violently agitated, as will be shown by the agitation of the grains of sand. And thus the positions of the antinodes can be rendered manifest.

(b) Again, suppose a pipe to be constructed with holes bored in one of its sides, and these covered by little doors which can be opened and shut, as shown in fig. 261. Let us suppose the little doors to be shut and the pipe to be caused to produce such a note that the nodes are at N and N', and the antinodes at V, V', V''. At the latter points the density is that of the external air, and consequently if the door at V' is opened no change is produced in the note. At the former points, N and N', condensation and rarefaction are alternately taking place. If now the door at N' is opened, this alternation of density is no longer possible, for the density at this open point must be the same as that of the external air, and consequently N' becomes an antinode, and the note yielded by the tube is changed. The change of notes produced by changing the fingering of the flute is one form of this experiment.

(c) Suppose A, in fig. 262, to be a pipe emitting a certain note, and suppose P to be a plug, fitting the tube, fastened to the end of a long rod by which it can be forced down the tube. Now, when the plug is inserted, whatever be its position, there will be a node in contact with it. Consequently, as it is gradually forced down, the note yielded by the pipe will keep on changing. But every time it reaches a position which was occupied by a node before its insertion, the note becomes the same as the note originally yielded. For now the column of air vibrates in exactly the same manner as it did before the plug was put in.

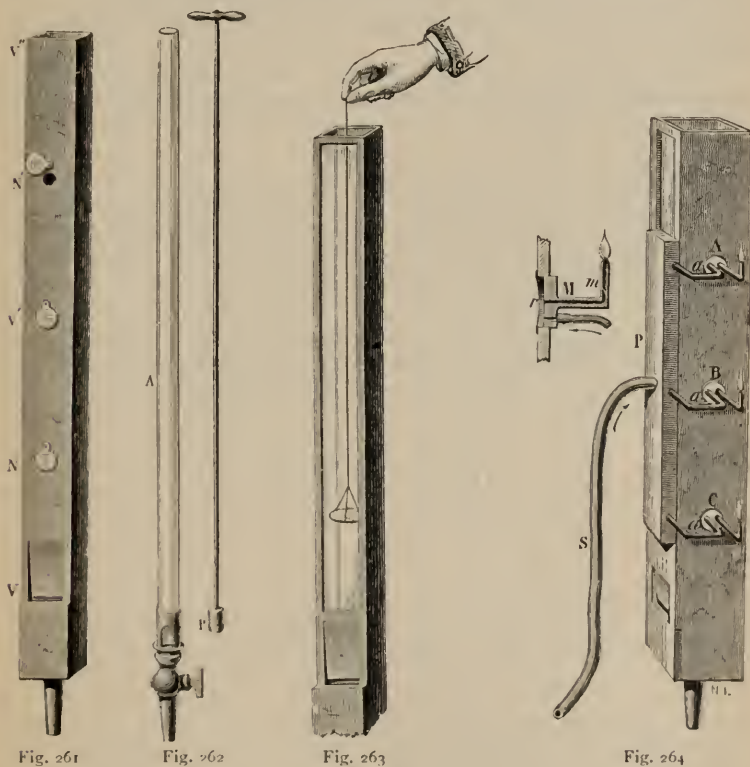

Fig. 261

Fig. 262

Fig. 263

Fig. 264

(d) Fig. 264 shows another mode of illustrating the same point, which is identical in principle with König's manometric flames. The figure represents an organ pipe, on one side of which is a chest, P, filled with coal gas, by means of the tube S. The gas from the chest comes out in three jets, A, B, C, and is then ignited. The manner in which the gas passes from the chest to the point of ignition is shown in the smaller figure, which is an enlarged section of A. A circular hole is bored in the side of the pipe and covered with a membrane r . A piece of wood is fitted into the hole so as to leave a small space between it and the membrane. The gas passes from

the chest in the direction indicated by the arrow, into the space between the membrane and the piece of wood, and so out of the tube m , at the mouth of which it is ignited. Now suppose the pipe to be caused to yield its fundamental note, then, as it is an open pipe, there ought to be a node at B, its middle point. Consequently, there ought to be rapid changes of density at B; these would cause the membrane r to vibrate, and thereby blow out the flame m , and this is what actually happens. If by increasing the force of the wind the octave of the fundamental note is produced, B will be a loop, and A and C nodes. Consequently, the flames at A and C will now be extinguished, as is, in point of fact, the case. But at B, there being no change of density, the membrane is unmoved, and the flame continues to burn steadily.

By each and all of these experiments it is shown that in a given pipe, whether open or closed, there are always a certain number of *nodes*, and between any two consecutive nodes there is always a *loop* or *ventral segment*.

276. We may determine the velocity of sound in air by making use of the vibration of air in a closed pipe. For this purpose the apparatus required is of a very simple description, consisting of a tall cylindrical glass jar, A, nearly full of water, a glass tube, ac , about an inch in diameter, and a tuning-fork of known pitch (fig. 265). Since $v = \lambda n$, where v is the velocity of sound in air, n the vibration-frequency of the note of the tuning-fork, and λ the wave-length in air of this note, it is clear that if we know n and can determine λ , the velocity of sound in air is obtained. Let the tuning-fork be sounded and held over the mouth of the tube ac , which is supported vertically in the cylinder A so as to form an air-column, ab , open at the top and closed at the bottom. The air in this column is set in vibration by the tuning-fork, and tends to augment its sound; and as the tube ac is raised and lowered, the reinforcement is a maximum for a certain definite length of ab . This length, l , is one-quarter of the wave-length in air of the note of the tuning-fork, so that $\lambda = 4l$. For suppose the lower prong of the fork to move downwards: it compresses the air in front of

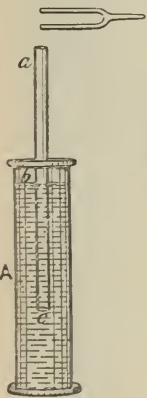

Fig. 265

it, and the compression travels a distance $\frac{\lambda}{2}$, or from a to c ,

and back again by the time the prong has reached its lowest position. Similarly, in the time the fork takes to return, the rarefaction travels from a to b and back to a . Thus the pulse in air travels the distance ab four times during a complete vibration of the fork. If ab be less or greater than $\lambda/4$, there will not be complete resonance and the sound will be feebler.

The same method may be used, with suitable modifications, for other gases.

277. **Formulæ relative to the number of vibrations produced by a musical pipe.**—It follows from what has been said that the column of air in stopped pipes is always divided by the nodes and loops into an uneven number of parts which are equal to one another, and each of which is a quarter of a wave-length (figs. 255, 256, and 257), while in an open pipe it is divided into an even number of such parts (figs. 258, 259, and 260). If L is

the length of the pipe, l the wave-length of the sound which it emits, and p any whole number, then for stopped pipes we have $L = (2p - 1) \frac{l}{4}$; and for

open pipes $L = 2p \frac{l}{4} = \frac{pl}{2}$. Replacing in each of these formulæ l by its value

$\frac{v}{n}$ (226), we have $L = (2p - 1) \frac{v}{4n}$ and $L = \frac{pv}{2n}$; from which for stopped pipes

we have $n = \frac{(2p - 1)v}{4L}$, and for open ones $n = \frac{pv}{2L}$.

The laws connecting the length of pipes with the note produced only hold for narrow pipes—those, for instance, whose length is not less than 12 times their diameter; for shorter pipes organ-builders have varied empirical rules. Within wide limits the formula holds, $L' = L - \frac{2}{3}d$, where L is the theoretical length, L' the length sought, while d is the diameter of the sound pipe.

If, in the first formula, we give to p the successive values 1, 2, 3, 4, &c., we have $n = \frac{v}{4L}, \frac{3v}{4L}, \frac{5v}{4L}$, that is the fundamental sound and all its uneven harmonics; and in the formula for the open pipe we get similarly $\frac{v}{2L}, \frac{2v}{2L}, \frac{3v}{2L}$, &c., that is the fundamental note and all its harmonics even and uneven.

278. **Explanation of the existence of nodes and loops in a musical pipe.** The existence of nodes and loops is to be explained by the coexistence in the same pipe of two equal waves travelling in contrary directions.

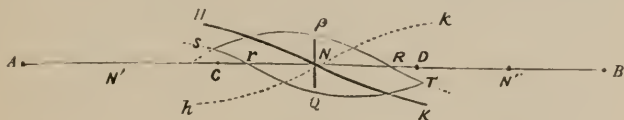

Fig. 266

Let A (fig. 266) be a point from which a series of waves sets out towards B, and let the length of these waves, whether of condensation or rarefaction, be AC, CD, DB. And let B be the point from which the series of exactly equal waves sets out towards A. It must be borne in mind that in the case of a wave of condensation originating at A the particles move in the direction A to B, but in a wave of condensation originating at B they move in the direction B to A. Now let us suppose that condensation at C, caused by the wave from A, begins at the same instant that condensation caused by the wave from B begins at D. Consequently, restricting our attention to the particles in the line CD, at any instant the velocities of the particles in CD due to the former wave will be represented by the ordinates of the curve SPRT, while those due to the wave from B will be represented by the ordinates of the curve TQR'S. Then, since the waves travel with the same velocity, and are at C and D respectively at the same instant, we must have, for any subsequent instant, CR equal to Dr. If, therefore, N is the middle point between C and D, we must have rN equal to RN, and consequently

PN equal to QN ; that is to say, if the particle at N transmitted only one vibration, its motion at each instant would be in the opposite phase to that of its motion if it transmitted only the other vibration. In other words, the particle N will at every instant tend to be moved with equal velocity in opposite directions by the two waves, and therefore will be *permanently* at rest. That point is therefore a *node*. In like manner, there is a node at N' midway between A and C, and also at N'' midway between B and D. In regard to the motion of the remaining particles, it is plain that their respective velocities will be the (algebraical) sum of the velocities they would at each instant receive from the waves separately. Hence, at the instant indicated by the diagram, they are given by the ordinates of the curve HNK. This curve will change from instant to instant, and at the end of the time occupied by the passage of a wave of condensation (or of rarefaction) from C to D will occupy the position shown by the dotted line $\dot{h}N\dot{k}$. It is evident therefore that particles near N have but small changes of velocity, whilst those near C and D experience large changes of velocity.

If the curve HK were produced both ways, it would always pass through N' and N'' ; the part, however, between N and N' would sometimes be on one side, and sometimes on the other side of AB. Hence all the particles between N' and N have simultaneously, first a motion in the direction A to B, and then a motion in the direction B to A, those particles near C having the greatest amplitude of vibrations. Accordingly near N and N' there will be alternately the greatest condensation and rarefaction.

This explanation applies to the case in which AB is the axis of an open organ pipe, A being the end where the mouthpiece is situated. The waves from B have their origin in the reflections of the series of waves from A. In the particular case considered, the note yielded by the pipe is that indicated by 3 ; that is, the fifth above the octave to the primary note. A similar explanation can obviously be applied to all other cases, whether the end is open or closed. But in the latter case the series of waves from the closed end must commence at a point distant from the mouthpiece by a space equal to one half, or three halves, or five halves, &c., of the length of a wave of condensation or expansion.

279. **Kundt's determination of the velocity of sound.**—Kundt has devised a method of determining the velocity of sound in solids and in gases which can be easily performed by means of simple apparatus, and is capable of great accuracy. A glass tube, BB', about two yards long (fig. 267) and two inches in internal diameter, is closed at one end by a movable stopper, *b* ; the other end is fitted with a cork, KK, which tightly grasps, at its middle point, a glass tube, AA', the same length, but of smaller diameter. This is closed at one end by a piston, *a*, which moves with gentle friction in the outer tube BB'. When the free end of the tube AA' is rubbed with a wet cloth, longitudinal vibrations are produced, which transmit their motion to the air in the tube *ab*. If the tube *ab* contain some lycopodium powder, or powdered cork, or ignited silicic acid, this is set in active vibration and then arranges itself in small patches in a certain definite order, as represented in the figure, the nature and arrangement of which depend on the vibrating part of the rod and the tube.

These heaps represent the nodes, and the mean distance *d* between

them can be measured with great accuracy; it represents the distance between two nodes, or half a wave-length; that is, the wave-length of the sound in air is $2d$. If the rod has the length s and is grasped in the middle by the cork KK , from the law of the longitudinal vibrations of rods (283), the wave-length of the sound it then emits is twice its length, or $2s$. That is, the wave-length of the vibrating column of air is to that in the rod as $2d : 2s$. As the velocity of sound in any medium is equal to the wave-length in that medium multiplied by the number of vibrations in a second, and since the number of vibrations is here the same in both cases, for the note is the same, the velocity of sound in the glass is to the velocity of sound in air as $2sn : 2dn$, that is as $s : d$. Thus when the glass tube was clamped in the middle by KK , so that the length ab was equal to half the length of the tube AA' , the number of the ventral segments was found to be eight. This corresponds to a ratio of wave-length of 1 to 16; in other words, the velocity of sound in glass is 16 times that in air.

The method is capable of great extension. By means of the stopcock m , different gases could be introduced instead of air, and corresponding differences found for the length of the ventral segments; from which, by a simple calculation, the corresponding velocities were found. Thus the velocities of sound in carbonic acid, coal gas, and hydrogen were found to be respectively 0.8, 1.56, and 3.56 that of air, or nearly as the inverse squares of the densities.

So, also, by varying the material of the rod AA' , different velocities are obtained. Thus the velocity in steel was found to be 15.24, and that in brass 10.87 that of air.

Kundt's figures may likewise be obtained by introducing into glass tubes a yard or two in length some lycopodium powder, as in the above experiment, and hermetically sealing the tubes at both ends. They are then put into longitudinal vibration; instead of air they may be filled with hydrogen or any other gas.

Using this method, with fine iron filings instead of lycopodium, Kundt and Lehmann determined the velocity of sound in water contained in glass tubes of various diameters and thicknesses; the thicker the tubes and the smaller their diameter, the more nearly do the results agree with those required by theory and with those obtained by Colladon and Sturm (234).

By surrounding the tube with a jacket which can be raised to various constant temperatures by the vapours of different liquids, the velocity of sound in such vapours may be determined.

280. **Chemical harmonicon.**—The air in an open tube may be made to give a sound by means of a luminous jet of hydrogen, coal gas, &c. When a glass tube about 12 inches long is held over a lighted jet of hydrogen (fig. 268), a note is produced which, if the tube is in a certain position, is the fundamental note of the tube. The sounds are considered to arise from the successive, exceedingly rapid explosions produced by the periodic

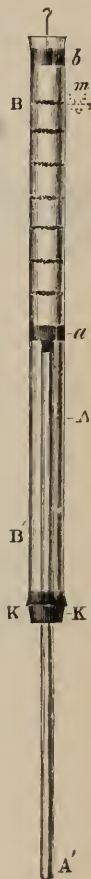

Fig. 267

combinations of the atmospheric oxygen with the issuing jet of hydrogen. The apparatus is called the *chemical harmonicon*.

The note depends on the size of the flame and the length of the tube : with a long tube, by varying the position of the jet in the tube, the series of notes, in the ratio 1 : 2 : 3 : 4 : 5, is obtained.

If, while the tube emits a certain sound, the voice or the siren (242) is gradually raised to the same height, as soon as the note is nearly in unison with the harmonicon, the flame becomes agitated, jumps up and down, and is finally steady when the two sounds are in unison. If the note of the siren is gradually heightened, the pulsations again commence ; they are the optical expressions of the beats (263) which occur near perfect unison.

If, while the jet burns in the tube and produces a note, the position of the tube is slightly altered, a point is reached at which no sound is heard. If now the voice, or the siren, or the tuning-fork, be pitched at the note produced by the jet, it begins to sing, and continues to sing even after the siren is silent. A mere noise, or shouting at an incorrect pitch, agitates the flame, but does not cause it to sing.

These effects may also be conveniently studied by means of a gas-burner, over which, at a distance of four inches, a ring covered with fine wire gauze is fixed. The gas is lighted above the gauze, and forms a very sensitive flame, especially when a moderately wide tube is held over the gauze. If the gauze is raised with the tube, the flame becomes duller and smaller, but begins to sound with a uniform loud tone. If now the gauze is lowered so that the flame is just silent, it begins at once when a sound is produced, but ceases with the sound.

If a metal tube 4 cm. wide and 15 to 20 cm. high, closed at the bottom by a wire gauze, is held vertically over a Bunsen's jet, an acute sound is heard, almost as loud as the whistle of a locomotive, on lighting the gas inside the tube.

Such sensitive flames are very conveniently produced by means of coal gas stored in pressure bags, connected by means of an india-rubber tube with a slender conical brass tube, ending in a steatite burner having a fine aperture. Pressure is applied to the bags and the supply of gas is regulated by a tap. In this way the gas when ignited may be made to burn with a flame A (fig. 269), a couple of feet in length, which is highly sensitive ; the slightest noise in the room, the crumpling of paper for example, causes this form to change to

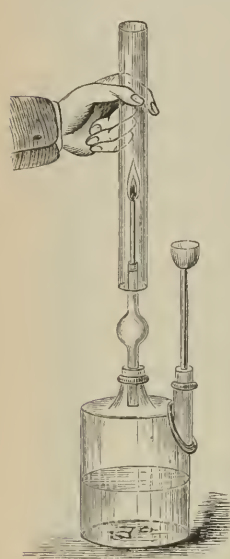

Fig. 268



Fig. 269

that of B : the rattling of keys or the sound of a whistle causes it to shrink still more.

281. **Stringed instruments.**—Stringed musical instruments depend on the production of transverse vibrations. In some, such as the piano, the sounds are *constant*, and each note requires a separate string ; in others, such as the violin and guitar, the sounds are *varied* by the fingering, and can be produced by fewer strings.

In the piano the vibrations of the strings are produced by the stroke of the *hammer*, which is moved by a series of bent levers communicating with the keys. The sound is strengthened by the vibrations of the air in the sounding board on which the strings are stretched. Whenever a key is struck, a *dampner* is raised which falls when the finger is removed from the key, and stops the vibrations of the corresponding string. By means of a *pedal* all the dampers can be simultaneously raised, and the vibrations then last for some time.

The *harp* is a sort of transition from the instruments with constant to those with variable sounds. Its strings correspond to the natural notes of the scale ; by means of the pedals the length of the vibrating parts can be changed, so as to produce sharps and flats. The sound is strengthened by the sounding-box, and by the vibrations of all the strings harmonic with those played.

In the violin and guitar each string can give a great number of sounds according to the length of the vibrating part, which is determined by the pressure of the fingers of the left hand while the right hand plays the bow, or twitches the strings themselves. In both these instruments the vibrations are communicated to the upper face or *belly* of the sounding-box by means of the bridge over which the strings pass. These vibrations are communicated from the upper to the lower face or *back* of the box either by the sides or by an intermediate piece called the *sound-post*. The air in the interior is set in vibration by both faces, and the strengthening of the sound is produced by all these simultaneous vibrations. The value of the instrument consists in the perfection with which all possible sounds are intensified, which depends essentially on the quality of the wood, the mellowness of which increases with age, and on the relative arrangement of the parts.

Whether a string is twitched, or struck, or rubbed, the number of the vibrations is the same ; but the form of vibrations of the parts of the string, and therewith the number and strength of the harmonics, vary with the manner in which it is sounded, and with the nature of the string. The sharper the edge of the exciting body the shorter and broader are the waves, and therefore the higher and stronger are the harmonics and the shriller the clang ; if the strings are struck with a metal rod the harmonics are so predominant that the fundamental note is scarcely heard, and thus what is called a hollow sound is produced. The tone is fullest when the string is struck with the finger, and somewhat less so when it is struck with a soft hammer, as in the piano. The deeper harmonics are often stronger than the fundamental note, so that the note is not so strong, but is richer ; all the harmonics, which require a node at the place struck, are wanting. If a string is struck in the middle, none of the even harmonics are produced, and therefore all the octaves of the fundamental note are absent ; the tone

is nasal and hollow. This is the characteristic of a note which is wanting in the harmonics nearer and most allied to the fundamental note. If the string is struck near one end, the clang has a jingling character. Instrument makers, led by practised ears, have long found it advantageous that the piano be struck at one-seventh or one-ninth of the length of the string ; the reason for this advantage lies in the fact that in this way either the seventh or the ninth harmonic, both of which are unharmonic with the fundamental, are deadened, while the deeper harmonics—the octaves, fifths, thirds—preponderate, and the clang is rich and harmonious.

The higher harmonics fade away in gut-strings more rapidly than in metal wires ; hence the guitar and the harp are not so jingling as the zither.

282. **Wind instruments.**—All wind instruments may be referred to the different types of sounding tubes which have been described. In some, such as the organ, the notes are *fixed*, and require a separate pipe for each note, in others the notes are *variable*, and are produced by only one tube ; the flute, horn, &c., are of this class.

In the *organ* the pipes are of various kinds ; namely, mouth pipes, open and stopped, and reed pipes with apertures of various shapes. By means of *stops* the organist can produce any note by both kinds of pipe.

In the *flute*, the mouthpiece consists of a simple lateral circular aperture : the current of air is directed by means of the lips, so that it grazes the edge of the aperture. The holes at different distances are closed either by the fingers or by keys : when one of the holes is opened, a loop is produced in the corresponding layer of air, which modifies the distribution of nodes and loops in the interior, and thus alters the note. The whistling of a key is similarly produced.

The *pandæan pipe* consists of stopped pipes of different lengths corresponding to the different notes of the gamut.

In the trumpet, the horn, the trombone, cornet-à-piston, and ophicleide the lips form the reed, and vibrate in the mouthpiece. In the *horn*, different notes are produced by altering the distance of the lips. In the *trombone*, one part of the tube slides within the other, and the performer can alter at will the length of the tube, and thus produce higher or lower notes. In the *cornet-à-piston*, the tube forms several convolutions ; pistons placed at different distances can, when closed, cut off communication with other parts of the tube, and thus alter the length of the vibrating column of air.

CHAPTER V

VIBRATION OF RODS, PLATES, AND MEMBRANES

283. **Vibration of rods.**—The term *rods* is applied in acoustics to solids whose length is considerable in proportion to their breadth and thickness ; they are, nevertheless, so broad and thick that, while they have not the flexibility of strings, they are yet elastic enough to vibrate without being stretched like strings. They are ordinarily of wood, glass, metal, and more particularly of tempered steel. Like strings, they have two kinds of vibrations, *longitudinal* and *transverse*. Longitudinal vibrations are produced by fixing the rod at any part, and rubbing it lengthwise with a piece of cloth sprinkled with resin, if the rod is of wood or metal ; with a wet cloth if the rod is of glass.

The point at which the rod is clamped is a node ; if it is clamped in the middle and put into longitudinal vibration, it gives its fundamental note, the wave-length being twice its own length. This is thus analogous to the case of an open pipe. If the rod is clamped at one quarter its length, it gives the octave of the fundamental note.

If the same rod is clamped at one end, and made to vibrate longitudinally, its wave-length is four times its own length ; the case is analogous to that of a stopped pipe.

The elongation due to longitudinal vibration is as great as would be due to a pull of several tons. If a glass rod (fig. 270) is made to vibrate longitudinally by being rubbed with a wetted cloth, the glass is seen to split off at the ends in a number of ring-shaped fragments. Here the effect is due to the superposition of small vibrations ; a small effect frequently repeated may give rise to effects far exceeding those due to only one application.

Transverse vibrations are produced by clamping one end of a rod, or otherwise holding it firmly, and then passing a bow across the free part.

It is shown by calculation that *the number of transverse vibrations made in a given time by rods and thin plates of the same material is directly as their thickness and inversely as the square of their length.* The width of the plate does not affect the number of vibrations. A wide plate, however, requires a greater force to set it in motion than a narrow one.



Fig. 270

The laws of the longitudinal vibrations of strings are expressed in the formula $n = \frac{1}{2l} \sqrt{\frac{\mu}{d}}$ in which n , l , and d have all the same meaning as in the formula for the transverse vibrations, while μ is the modulus of longitudinal elasticity of the string (87).

Fig. 271 represents an instrument invented by Marloye, and known as *Marloye's harp*, based on the longitudinal vibration of rods. It consists of a solid wooden pedestal, in which are fixed twenty thin deal rods, some coloured and others white. They are of such a length that the white rods give the diatonic scale, while the coloured ones give the semitones and complete the chromatic scale. The instrument is played by rubbing the rods in the direction of their length between the finger and thumb, which have been previously covered with powdered resin. The notes produced resemble those of a pandæan pipe.

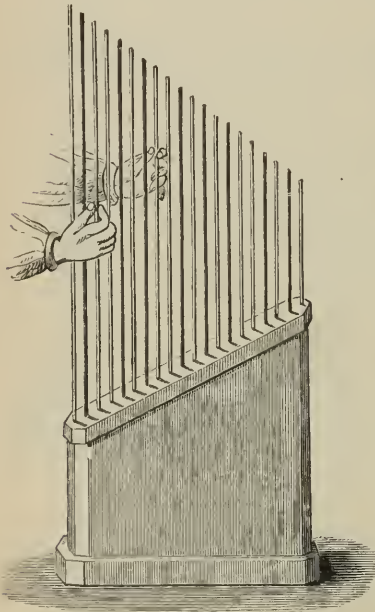

Fig. 271

The *tuning-fork*, the *triangle*, and *musical boxes* are examples of the transverse vibrations of rods. In musical boxes, small plates of steel of different dimensions are fixed on a rod, like the teeth of a comb. A cylinder whose axis is parallel to this rod, and whose surface is studded with steel teeth, arranged in a certain order, is placed near the plates. By means of a clockwork motion, the cylinder rotates, and the teeth striking the steel plates set them in vibration, producing a tune, which depends on the arrangement of the teeth on the cylinder.

The velocity of sound in any solid may be determined experimentally by clamping it at one end and putting it in longitudinal vibration. The length of a stopped pipe which gives the same note is next ascertained. The velocity of sound in the material in question is thus to its velocity in air in the same ratio as the length of the rod to the length of the stopped pipe. Thus a rod of alder a metre in length was found to give the same note as a stopped pipe 7 cm. in length; the velocities are accordingly as 100 : 7, or the velocity of sound in this wood is 14.3 times that in air.

Stefan has determined the velocity of sound in soft bodies by attaching them, in the form of rods, to long glass or wooden rods. The compound rod was made to vibrate, and the number of vibrations of the note was determined. Knowing this, and knowing also the velocity of sound in the longer rod, we are able to obtain at once the velocity in the shorter rod. By this method some of the numbers in the table in article 235 were obtained.

Scratching and scraping sounds are produced by moving a rod over a smooth surface ; the rod is thereby put in vibration, which vibrations are regular for a short interval, but frequently change their period during the motion.

284. **Vibration of plates.**—In order to make a plate vibrate, we must fix it at the centre (fig. 272), and draw a bow rapidly across one of the edges ; or else fix it at any point of its surface, and rapidly draw a string covered with resin against the edges of a central hole (fig. 273).

Vibrating plates contain nodal lines (270), which vary in number and position according to the form of the plates, their elasticity, the mode of excitation, and the number of vibrations. These nodal lines may be made visible by covering the plate with fine sand before it is made to vibrate. As soon as the vibrations commence, the sand leaves the vibrating parts and accumulates on the nodal lines, as seen in figs. 272 and 273.



Fig. 272

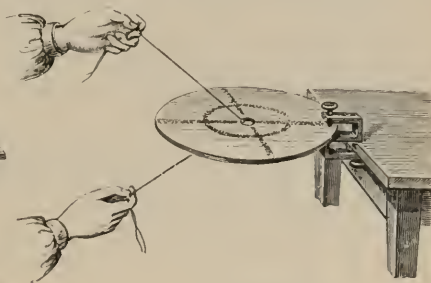

Fig. 273

The position of the nodal lines may be determined by touching the points at which it is desired to produce them. The number increases with the number of vibrations ; that is, as the note given by the plates is higher. The nodal lines always possess great symmetry of form, and the same form is always produced on the same plate under the same conditions. They were discovered by Chladni, and the plates are known as *Chladni's plates*.

The vibrations of plates are governed by the following law :— *In plates of the same kind and shape, and giving the same system of nodal lines, the number of vibrations in a second is directly as the thickness of the plates, and inversely as their area.*

Gongs and cymbals are examples of instruments in which sounds are produced by the vibration of metal plates. The *glass* and the *steel harmonicon* depend on the vibrations of glass and of steel plates respectively.

Bells, which are to be regarded as curved plates, never vibrate as a whole but when they give their fundamental note in four equal parts which are separated by nodal lines. This can be shown by suspending pith balls by

silk threads from the ends of glass rods arranged crosswise, so that the pith balls just rest against the rim of a bell jar held vertically with the mouth upwards. When this is made to sound by drawing a bow across the edge the balls are powerfully repelled from the ventral segments, but with far less force from the nodes.

Bells are also capable of vibrating in 6, 8, 10, or 12 parts, producing thus a corresponding series of over-tones. The note of a bell is higher in proportion as the surface is smaller and the substance thicker.

If a bell jar containing water is made to vibrate by means of a violin bow, the surface of the water forms a series of nodes and segments, and water is projected in the form of spray from the ventral segments. If alcohol or ether be used instead of water, a number of droplets form and group themselves into beautiful starlike figures.

285. **Vibration of membranes.**—In consequence of their flexibility, membranes cannot vibrate unless they are stretched, like the skin of a drum. The sound they give is more acute in proportion as they are smaller and more tightly stretched. To obtain vibrating membranes, Savart fastened gold-beater's skin on wooden frames.

In the *drum*, the skins are stretched on the ends of a cylindrical box. When one end is struck, it communicates its vibrations to the internal column of air, and the sound is thus considerably strengthened. The cords stretched against the lower skin strike against it when it vibrates, and produce the sound characteristic of the drum.

Membranes either vibrate by direct percussion, as in the drum, or they may be set in vibration by the vibrations of the air, provided these are

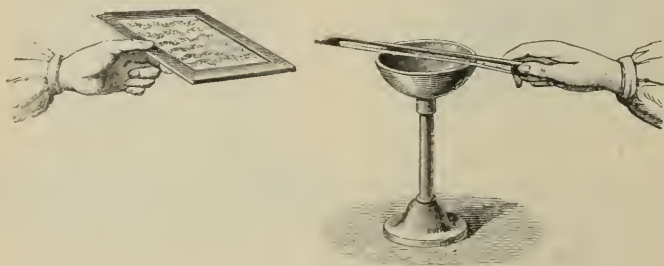

Fig. 274

sufficiently strong. Fig. 274 shows a membrane vibrating under the influence of the vibrations in the air caused by a sounding bell. Fine sand strewn on the membrane shows the formation of nodal lines just as upon plates.

Membranes are eminently fitted for taking up the vibrations of the air, on account of their small mass, their large surface, and the readiness with which they subdivide. With a pretty strong whistle, nodal lines may be produced in a membrane stretched on a frame, even at the distant end of a large room. The phenomenon so easily produced in easily moved bodies is also found in larger and less elastic masses; all the pillars and walls of a church vibrate more or less while the bells are being rung.

CHAPTER VI

GRAPHICAL METHOD OF STUDYING VIBRATORY MOTIONS

286. **Lissajous' method of making vibrations apparent.**—The method of Lissajous exhibits the vibratory motion of bodies either directly or by projection on a screen. It has also the great advantage that the vibratory motions of two sounding bodies may be compared *without the aid of the ear*, so as to obtain the exact relation between them.

This method, which depends on the persistence of visual sensations on the retina, consists in fixing a small mirror on the vibrating body, so as to vibrate with it, and impart to a luminous ray a vibratory motion similar to its own.

Lissajous uses tuning-forks and fixes to one of the prongs a small metal mirror, *m* (fig. 275), and to the other a counterpoise, *n*, which is necessary to make the tuning-fork vibrate regularly for a long time. At a

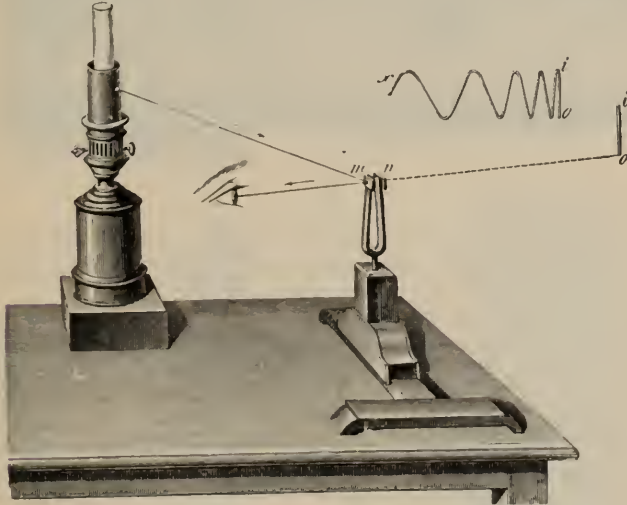

Fig. 275

few yards' distance from the mirror is a lamp with a dark chimney, in which is a small hole giving a single luminous point. The tuning-fork being at rest, the eye is placed so that the luminous point is seen at *o*. The tuning-fork being made to vibrate, the image elongates, forming a persistent image,

oi, which diminishes in proportion as the amplitude of the oscillation decreases. If, during the oscillation of the mirror, it is also made to rotate by rotating the tuning-fork on its axis, a sinuous line, *oix*, is produced instead of the straight line *oi*. These different effects are explained by the successive displacements of the luminous pencil, and by the duration of these luminous impressions on the eye after the cause has ceased.

If, instead of viewing these effects directly, they are projected on a screen, the experiment is arranged as shown in fig. 276 ; the pencil reflected

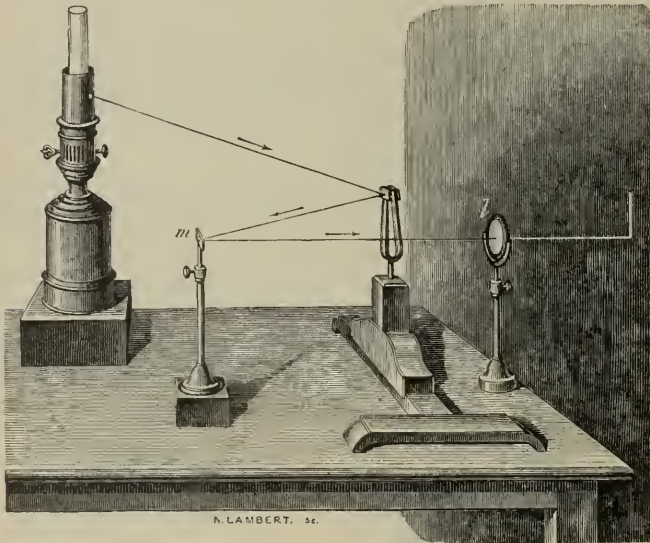

Fig. 276

from the vibrating mirror is reflected a second time from the fixed mirror, *m*, which sends it towards an achromatic lens, *l*, placed so as to project the images on the screen.

287. **Combination of two vibratory motions in the same direction.**—Lissajous resolved the problem of the optical combination of two vibratory motions—vibrating at first in the same direction, and then at right angles to each other.

Fig. 277 represents the experiment as arranged for combining two parallel motions. Two tuning-forks provided with mirrors are so placed that the light reflected from one of them reaches the other, which is almost parallel to it, and is then sent towards a screen after having passed through a lens.

If now the first tuning-fork alone vibrates, the image on the screen is the same as in fig. 277 ; but if they both vibrate, supposing they are very nearly in unison, the elongation increases or diminishes according as the simultaneous motions imparted to the image by the vibrations of the mirrors do or do not coincide.

If the tuning-forks pass their position of equilibrium in the same time and in the same direction, the image attains its maximum ; and the image is at its minimum when they pass at the same time but in opposite directions. Between these two extreme cases, the amplitude of the image varies according to the time which elapses between the exact instant at which the tuning-forks pass through their position of rest respectively. The ratio of

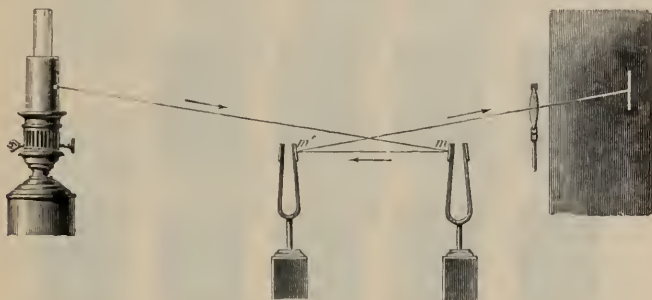

Fig. 277

this time to the time of a complete vibration is called a *difference of phase* of the vibration.

If the tuning-forks are exactly in unison, the luminous appearance on the screen experiences a gradual diminution of length in proportion as the amplitude of the vibration diminishes ; but if the pitch of one is very little altered, the magnitude of the image varies periodically, and, while the beats resulting from the imperfect harmony are distinctly heard, the eye sees the concomitant pulsations of the image.

288. **Optical combination of two vibratory motions at right angles to each other.**—The optical combination of two rectangular vibratory motions

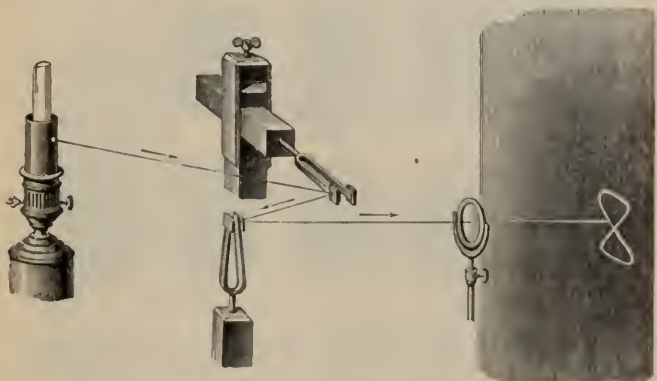

Fig. 278

is effected as shown in fig. 278 ; that is, by means of two tuning-forks, one of which is horizontal and the other vertical, and both provided with mirrors.

If the horizontal fork first vibrates alone, a horizontal luminous outline is seen on the screen, while the vibration of the other produces a vertical image. If both tuning-forks vibrate simultaneously, the two motions combine, and the reflected pencil describes a more or less complex curve, the form of which depends on the number of vibrations of the two tuning-forks in a given time. This curve gives a valuable means of comparing the number of vibrations of two sounding bodies.

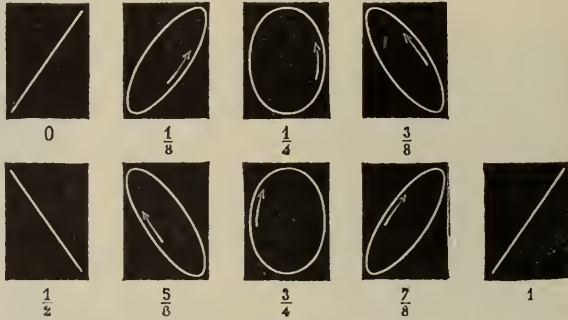

Fig. 279

Fig. 279 shows the luminous image on the screen when the tuning-forks are in unison; that is, when the number of vibrations is equal.

The fractions below each curve indicate the differences of phase between them. The initial form of the curve is determined by the difference of phase. The curve retains exactly the same form when the tuning-forks are in unison, provided that the amplitudes of the two rectangular vibrations decrease in the same ratio.

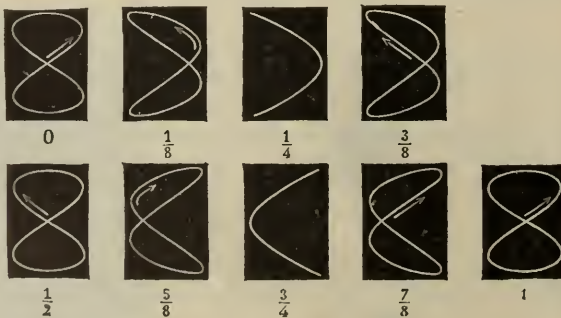

Fig. 280

If the tuning-forks are not quite in unison, the initial difference of phase is not preserved, and the curve passes through all its variations.

Fig. 280 represents the different appearances of the luminous image when the difference between the tuning-forks is an octave; that is, when the

numbers of their vibrations are as 1 : 2 ; and fig. 281 gives the series of curves when the numbers of the vibrations are as 3 : 4.

It will be seen that the curves are more complex when the ratios of the

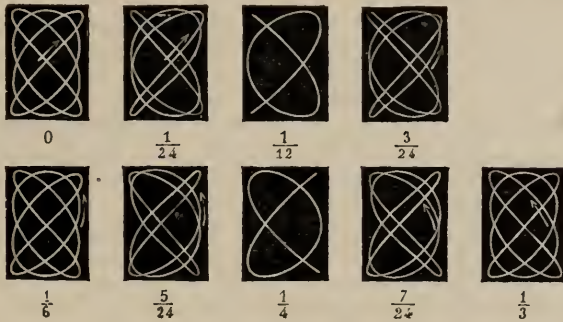

Fig. 281

numbers of vibrations are less simple. Lissajous examined these curves theoretically, and has calculated their general equations.

It has been shown in art. 58 how such figures may be produced by means of two pendulums oscillating in rectangular planes.

When these experiments are made with the electric light instead of an ordinary lamp, the phenomena are remarkably brilliant.

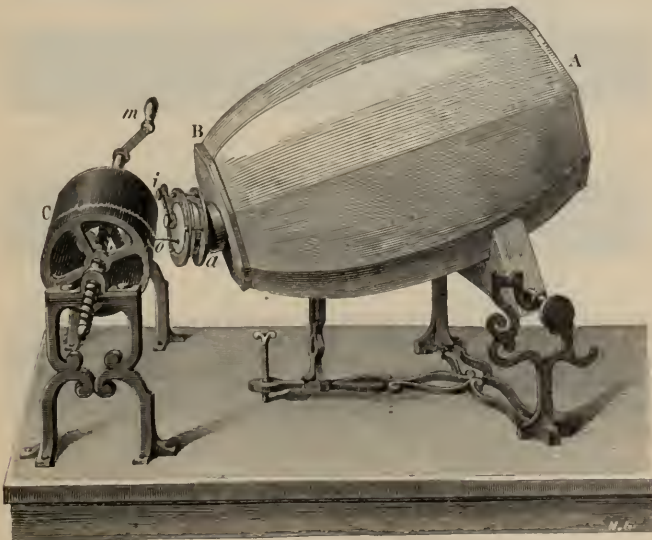

Fig. 282

289. Léon Scott's Phonautograph.—This apparatus registers not only the vibrations produced by solid bodies, but also those produced by wind

instruments, by the voice in singing, and even by any noise whatsoever : for instance, that of thunder, or the report of a cannon. It consists of an ellipsoidal barrel, AB (fig. 282), about a foot and a half long and a foot in its greatest diameter, made of plaster of Paris. The end A is open, but the end B is closed by a solid bottom, to the middle of which is fixed a brass tube *a*, bent at an elbow and terminated by a ring, on which is fixed a flexible membrane which, by means of a second ring, can be stretched to the required extent. Near the centre of the membrane, fixed by sealing-wax, is a hog's bristle, which acts as a style, and, of course, shares the movements of the membrane. In order that the style shall not be at a *node*, the stretching ring is fitted with a movable piece, *i*, or *subdivider*, which, being made to touch the membrane first at one point and then at another, enables the experimenter to alter the arrangements of the nodal lines at will. By means of the subdivider, the point is made to coincide with a loop ; that is, a point where the vibrations of the membrane are at a maximum.

When a sound is produced near the apparatus, the air in the ellipsoid, the membrane, and the style will vibrate in unison with it, and it only remains to trace on a sensitive surface the vibrations of the style, and to fix them. For this purpose there is placed in front of the membrane a brass cylinder, C, turning round a horizontal axis by means of a handle, *m*. On the prolonged axis of the cylinder a screw is cut which works in a nut ; consequently, when the handle is turned, the cylinder gradually advances in the direction of its axis. Round the cylinder is wrapped a sheet of paper covered with a thin layer of lampblack.

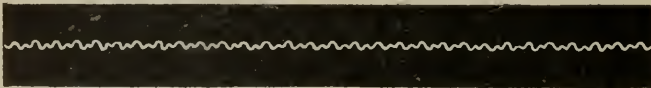

Fig. 283



Fig. 284

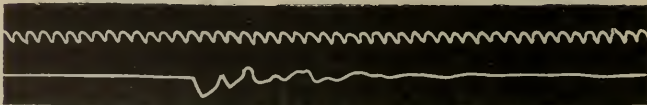

Fig. 285

The apparatus is used by bringing the prepared paper into contact with the point of the style, and then setting the cylinder in motion round its axis. So long as no sound is heard, the style remains at rest, and merely removes the lampblack along a line which is a helix on the cylinder, but which becomes straight when the paper is unwrapped. But when a sound is heard, the membrane and the style vibrate in unison, and the line traced out is no longer straight but undulates, each undulation corresponding to a double

vibration of the style. Consequently, the figures thus obtained faithfully denote the number, amplitude, and isochronism of the vibrations.

Fig. 283 shows the trace produced when a simple note is sung, and strengthened by means of its upper octave. The latter note is represented by the curve of lesser amplitude. Fig. 284 represents the sound produced jointly by two pipes whose notes differ by an octave. The lower line of fig. 285 represents the rolling sound of the letter R when pronounced with a ring.

The upper line of fig. 285 represents the perfectly isochronous vibrations of a tuning-fork placed near the ellipsoid. This line was traced by a fine point on one branch of the fork, which was thus found to make exactly 500 vibrations per second. Hence, each undulation of the upper line corresponds to the $\frac{1}{500}$ part of a second; and thus these lines become very exact means of measuring short intervals of time. For example, in fig. 285 each of the separate shocks producing the rolling sound of the letter R corresponds to about 18 double vibrations of the tuning-fork, and consequently lasts about $\frac{18}{500}$ or about $\frac{1}{28}$ of a second.

290. **König's manometric flames.**—König's method consists in transmitting the motion of the waves which form a sound to gas flames, which, by their pulsations, indicate the nature of the sounds. For this purpose a

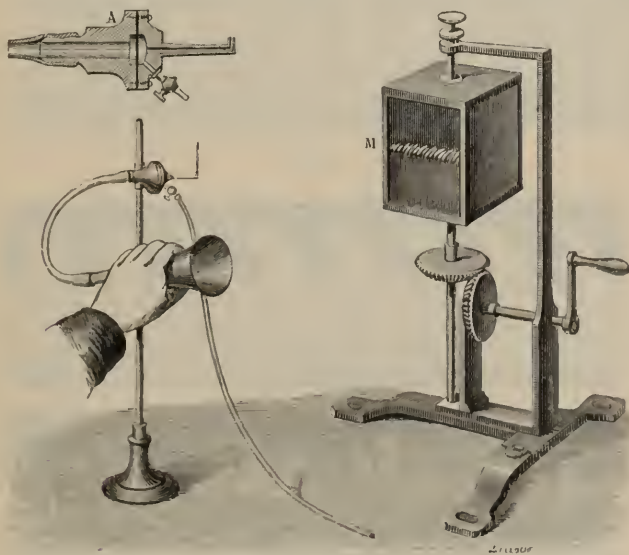

Fig. 286

metal capsule, represented in section at A, fig. 286, is divided into two compartments by a thin membrane of india rubber; on the right of the figure is a gas jet, and below it a tube conveying coal gas; on the left is a tubule, to which may be attached an india-rubber tube. The other end of this

may be placed at the node of an organ pipe (275), or it terminates in a mouthpiece in front of which a given note may be sung: this is the arrangement represented in fig. 286.

Fig. 287

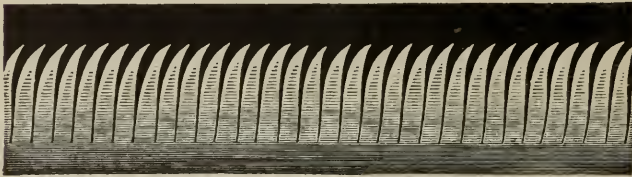
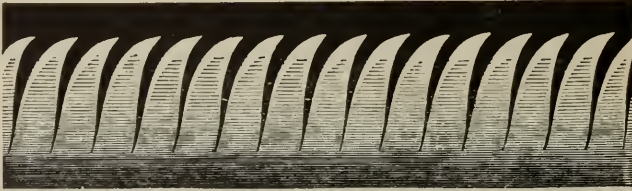

Fig. 288

When the sound-waves enter the capsule by the mouthpiece and the tube, the membrane yielding to the condensation and rarefaction of the waves, the coal gas in the compartment on the right is alternately contracted and expanded, and hence are produced alternations in the length of the

Fig. 289

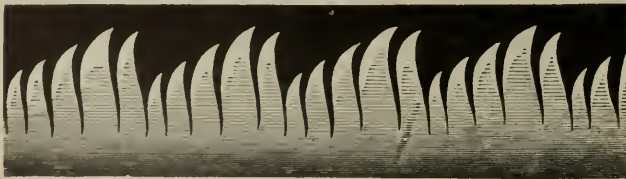

Fig. 290

flame, which are, however, scarcely perceptible when the flame is observed directly. To render them distinct we may make use of a mirror with four faces, M, which may be turned by two cog-wheels and a handle. As

long as the flame burns steadily, there appears in the mirror, when turned, a continuous band of light. But, if the capsule is connected with a sounding-tube yielding the fundamental note, the image of the flame takes the form represented in fig. 287, and that of fig. 288 if the sound yields the octave. If the two sounds reach the capsule simultaneously, the flame has the appearance of fig. 289; in that case, however, the tube leading to the capsule must be connected by a T-pipe with two sounding-tubes, one giving the fundamental note, and the other the octave. If one gives the fundamental note and the other the third, the flame has the appearance of fig. 290.

Fig. 291



Fig. 292

If the vowel E is sung in front of the mouthpiece first upon c , and then upon c' , the mirror gives the flames represented in figs. 291 and 292.

291. **Determination of the intensity of sounds.**—Meyer has devised a plan by which the intensities of two sounds of the same pitch may be directly compared. The two sounds are separated from each other by a medium impervious to sound, and in front of each of them is a resonance-globe (256) accurately tuned to the sound. Each of these resonance-globes is attached by means of india-rubber tubes of equal length to the two ends of a U-tube, in the middle of the bend of which is a third tube provided with a manometric capsule. If the resonance-globes are each at the same distance from the sounding bodies, and if the note of only one of them is produced, the flame vibrates. If both sounds are produced, and they are of the same intensity, and in the same phase, they interfere completely in the tube, so that the flame of the manometric capsule is quite stationary, and appears in the turning mirror as a straight luminous band.

If, however, the sounds are not of the same intensity, the interference will be incomplete, and the luminous band will be jagged at the edge. The distance of one of the sounds from the resonance-globes is altered until the flame is stationary. The intensities of the two sounds are then directly as the squares of their distances from the resonators.

292. **Acoustic attraction and repulsion.**—It was observed by Guyot, and afterwards independently by Guthrie and by Schellbach, that a sounding body, one in a state of vibration therefore, exercises an action on a body in its neighbourhood which is sometimes one of attraction and sometimes of repulsion. The vibrations of an elastic medium attract bodies which are specifically heavier than itself, and repel those which are specifically lighter. Thus a balloon of goldbeater's skin filled with carbonic acid is attracted towards the opening of a resonance-box on which is a vibrating tuning-fork; while a similar balloon filled with hydrogen and tied down by a thread is repelled. This result always follows, even when the hydrogen balloon is made heavier than air by loading it with wax.

A light piece of cardboard suspended and held near a tuning-fork moves towards it when the fork is made to vibrate. If the tuning-fork is suspended and is then made to vibrate, it moves towards the card if the latter is fixed. Two suspended tuning-forks in a state of vibration move towards each other. The flame of a candle placed near the end of a sounding tuning-fork is repelled if held near it; if held underneath, it flattens out to a disc. A gas flame near the end of the tuning-fork divides into two arms.

Guthrie found that, when one prong of a tuning-fork is enclosed in a tube drawn out to a capillary portion dipping into a liquid, and is set in vibration by bowing the free prong, the air around the enclosed prong is expanded, and he thence concluded that the approach, above described, of a suspended body to the sounding-fork is due to the diminution of the pressure of the air between the fork and the body below that on the other side of the body.

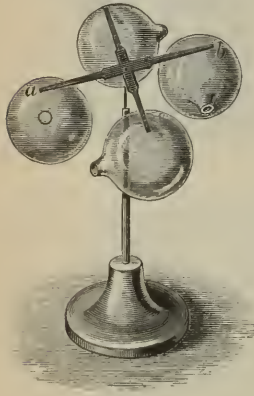

Fig. 293

A cylindrical resonator of stiff drawing-paper is fastened to a strip of wood, which is provided with a glass cap and counterpoise, and thus can be made to turn on a needle-point. If the open end of the sounding-box of a tuning-fork vibrating in unison with the resonator is brought near this, it is repelled even at a distance of some inches. When a small mill with four arms (fig. 293), each provided with a small resonator, is placed near the open end of the sounding-box, the repulsion is so strong as to produce a uniform rotation.

These phenomena do not seem to be due to the aspirating action of currents of air, nor are they caused by any heating effect; and it must be confessed that the phenomena require further elucidation; they are of special interest as furnishing a possible clue to the solution of the problem of attraction in general.

293. **Phonograph. Graphophone.**—In the year 1877 Edison devised the apparatus known as the *phonograph* for recording and reproducing sound, which was equally remarkable for the simplicity of its construction and for the striking character of the results which it produced.

This instrument in its original form is illustrated in fig. 294, and it consisted generally of a cylinder C, mounted on a horizontal axis AA' which could

he rotated beneath a mouthpiece E, by means of a winch-handle M, the speed of rotation being controlled by a fly-wheel attached to one end of the spindle AA'. Upon the cylindrical surface of C was cut a helical groove, and one end of the spindle A' was formed into a screw, the pitch of which was equal to that of the groove upon the cylinder. This screw worked in a correspondingly screwed bearing, so that, on turning the handle, the cylinder not only rotated upon its axis, but also travelled from end to end in a direction parallel to its axis.

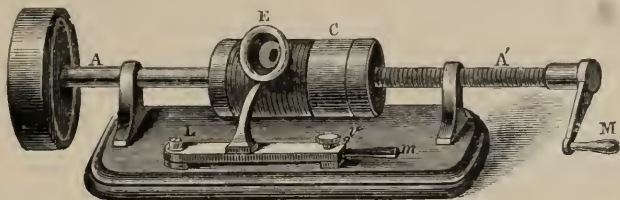

Fig. 294

The mouthpiece was closed with a diaphragm or membrane P (fig. 295), to the centre of which was attached, by means of an india-rubber tube, a small style S, directed towards the cylinder, and caused to vibrate longitudinally by the vibratory action of the diaphragm P, and the position of the mouth-piece was so adjusted that the point of the style was always directed to the centre of the helical groove in the cylinder. On this grooved cylinder was stretched a sheet of tinfoil which bridged over the grooves, being supported by the ridges and the position of the mouth-piece, and its distance from the cylinder was adjusted by the handle *m*, which could be fixed in its place by the set screw *z*. Their position and distance were so adjusted that when the apparatus was at rest the point of the style was within the groove and a little lower than the top of the ridge.

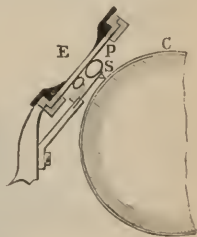

Fig. 295

If, while the cylinder was being rotated, sounds or words were uttered into the mouthpiece, the diaphragm attached thereto was set into vibration and caused the style to indent on the foil a groove of varying depth, the bottom of which was a mechanical record of the vibration of the diaphragm, and therefore of the sounds by which those vibrations were set up, and as tinfoil is a very imperfectly elastic material it is able to retain a record so made.

When this record was passed again beneath the style the varying indentations on the foil caused the style to vibrate as it did when it produced the indentations, and the diaphragm was similarly set into vibration, and reproduced the sound by which it was in the first instance set into vibration.

In this way sound could be reproduced so as to be audible to a large audience; the articulation was distinct though feeble; it reproduced the voice of a person who spoke into it, but with a nasal intonation. Speech could thus be stored up on a sheet of tinfoil and kept for an indefinite period, and the sound could be reproduced more than once from the same record, but after a second reproduction the clearness was greatly diminished.

If the velocity of rotation were greater than before, the pitch of the sound was raised ; and if the speed were not uniform, then, in the case of a song, the reproduction was incorrect. In order to produce a uniform velocity the instrument may, with advantage, be driven by clockwork.

There was a great difference in the distinctness with which the various consonants and vowels were reproduced ; the most distinct were words containing the vowels A, O, and U, and the consonants *t*, *k*, and *r* ; the *s* and similar consonants, on the contrary, were seldom distinct. If the phonograph be rotated in the reverse direction, the sounds of which the words are made up retain their character, but are produced in the reverse order.

The impressions on the tinfoil appear at first sight as a series of successive points or dots, but when examined under a microscope they are seen to have a distinct form of their own. When a cast is taken by means of fusible metal and a longitudinal section made, the outline closely resembles the jagged edge of a König's flame. Mr. Edison stated that as many as 40,000 words can be registered on the foil on a space not exceeding 10 square inches.

The phonograph has been used with great advantage by Jenkins and King for the analysis of vocal sounds, for which purpose it is better suited than König's flames.

The *graphophone*, invented by Mr. Sumner Tainter, in conjunction with Professor Graham Bell and Dr. Chichester Bell, consists essentially of three parts : the recorder, the cylinder on which the record is made, and the reproducer.

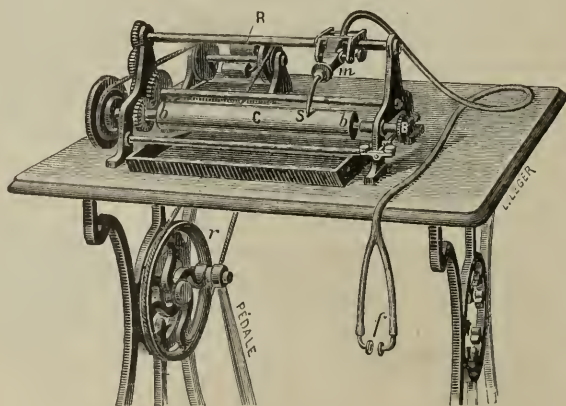

Fig. 296

The record is made on a hollow cylinder C (fig. 296) of cardboard, *bb*, coated with a composition of wax and paraffin ; it is mounted horizontally, and is rotated by means of a treadle underneath the table which supports the whole apparatus. Between the treadle and the cylinder is interposed a very ingenious governor, R, by which the speed of rotation of the cylinder may be regulated to perfect uniformity, the force required for this rotation being very small.

On a bar parallel to and in front of the cylinder is clamped the recorder,

which consists of an exceedingly minute cutting point, or rather chisel, fixed to a mica diaphragm. This diaphragm is at the end of a flexible tube provided with a mouthpiece. If this is spoken into, the diaphragm vibrates with a to-and-fro motion, and if at the same time the cylinder rotates at a uniform speed the style cuts or carves out a groove in the surface of the wax, forming a very irregular outline which is the exact reproduction of the sound-wave. Therein lies the difference between the graphophone and the phonograph, for in the latter the record is produced by a process of indentation, while in the former the record of the sound-waves is engraved in a waxy material. The grooves are so excessively minute that their variations in depth cannot be recognised by the naked eye; they are not more than the $\frac{3}{10000}$ of an inch in diameter, and there are 160 to the inch.

The *reproducer* (fig. 297) consists of a light ebonite tube SM, at one end of which is the enlargement M containing the diaphragm, which, like that of the recorder, is of mica, but is somewhat smaller. The diaphragm is connected by means of a fine waxed silk thread *f*, with a fine steel point or hook *a*, which rocks on a pivot at the end of the tube. There is an arrangement by which this reproducer can be clamped in front of the recorder, so that when the

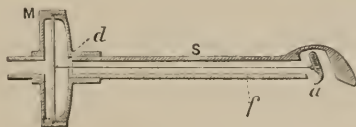

Fig. 297

cylinder is rotated the reproducer travels at a proportionate speed, allowing the small point to rest in the groove forming the sound record, along which it rides and vibrates; and these vibrations are transmitted to the mica diaphragm, and, being communicated to the ear by the tube *f*, faithfully reproduce the sound. Notwithstanding what appears the very yielding character of the wax, the sounds, and even elaborate pieces of music, are reproduced with great fidelity.

The phonograph of the present day is a more perfect instrument than that of 1877 or the graphophone. As in the latter instrument, the record is made on a cylindrical surface of wax, but, instead of a paper backing, it is a rigid hollow cylinder of wax, which is fitted into a slightly conical rotating mandril. The diaphragm of both recorder and reproducer is of glass, and one of the great improvements devised by Mr. Augustus Stroh is the substitution of sapphire styles for those of steel in the recorder and receiving apparatus. The modern instrument is further driven by an electric motor, which is quite silent, and by a very perfect governor; the speed of the rotation is almost absolutely uniform.

BOOK VI

ON HEAT

CHAPTER I

PRELIMINARY IDEAS. THERMOMETERS

294. **Heat. Hypothesis as to its nature.**—In ordinary language the term *heat* is used not only to express a particular sensation, but also to describe that particular state or condition of matter which produces this sensation. Besides producing this sensation, heat acts variously upon bodies ; it melts ice, boils water, makes metals red-hot, produces electric currents, decomposes compound bodies, and so forth.

Two theories as to the cause of heat have been propounded : these are the *theory of emission*, and the *theory of undulation*.

On the first theory, heat is a subtle imponderable fluid, which surrounds the molecules of bodies, and can pass from one body to another. The *heat atmospheres*, which thus surround the molecules, exert a repelling influence on each other, in consequence of which heat acts in opposition to the force of cohesion. The entrance of this substance into our bodies produces the sensation of warmth, its egress the sensation of cold.

On the second hypothesis the heat of a body is caused by an extremely rapid oscillating or vibratory motion of its molecules ; and the hottest bodies are those in which the vibrations are most rapid and have the greatest amplitude. At any given time the whole of the molecules of a body possess energy of motion, which is the heat they contain. To increase their temperature is to increase this energy ; to lower their temperature is to decrease their energy. Hence, on this view, heat is not a substance but a *condition of matter*, and a condition which can be transferred from one body to another. When a heated body is placed in contact with a cooler one, the former cedes more molecular motion than it receives ; but the loss of the former is the equivalent of the gain of the latter.

It is also assumed that there is an imponderable elastic ether, which pervades all matter and infinite space. A hot body sets this ether in rapid vibration, and the vibrations being communicated to material objects set their particles in more rapid vibration ; that is, increase their temperature. Here we have an analogy with sound ; a sounding body is in a state of

vibration, and its vibrations are transmitted by atmospheric air to the auditory apparatus in which is produced the sensation of sound.

This hypothesis as to the nature of heat is now admitted by the most distinguished physicists. It affords a better explanation of all the phenomena of heat than any other theory, and it reveals an intimate connection between heat and light. It will be subsequently seen that by the friction of bodies against each other an indefinite quantity of heat can be produced. Experiment has shown that there is an exact equivalence between the energy of the motion thus destroyed and the heat produced. These and many other facts are utterly inexplicable on the assumption that heat is a substance, and not a form of energy.

In what follows, however, the phenomena of heat will be considered, as far as possible, independently of either hypothesis; but we shall subsequently return to the reason for the adoption of the latter hypothesis.

Assuming that the heat of bodies is due to the motion of their particles, *i.e.* to their internal kinetic energy, we may admit the following explanation as to the nature of this motion in the various forms of matter:—

In *solids* the molecules of even the most rigid bodies have a kind of vibratory motion about certain fixed positions. This motion is probably very complex; the constituents of the molecule may oscillate about each other, this motion being in addition to the oscillation of the molecule as a whole; and this latter again may be a to-and-fro motion, or it may be a rotatory motion about the centre. In cases in which external forces, such as violent shocks, act upon the body, the molecules may permanently acquire fresh positions.

In the *liquid* state the molecules have no fixed positions. They can rotate about their centres of gravity, and the centre of gravity itself may move. But the motion due to collisions, compared with the mutual attraction of the molecules, is not sufficient to separate the molecules from each other. A molecule no longer adheres to particular adjacent ones; but it does not spontaneously leave them except to come into the same relation to fresh ones as to its previous adjacent ones. Thus in a liquid there is a vibratory, rotatory, and progressive motion of the molecules.

In the *gaseous* state the molecules are almost entirely without action upon each other; they neither attract nor repel each other. They fly forward in straight lines according to the ordinary laws of motion, until they impinge against other molecules or against a fixed envelope which they cannot penetrate, and then fly off in another direction, with, in the main, their original velocity. If the molecules were in space, where no external force could act upon them, they would fly apart, and disappear in infinity. But if contained in any vessel, the molecules continually impinge in all directions against the sides, and thus arises the pressure which a gas exerts on its containing vessel.

The perfection of the gaseous state, or what may be regarded as an *ideal* gas, implies that the space actually occupied by the molecules of the gas is infinitely small compared with the entire volume of the gas; that the time occupied by the impact of a molecule either against another molecule, or against the sides of the vessel, is infinitely small in comparison with the interval between any two impacts; and that the influence of molecular attraction is infinitely small. When these conditions are not fulfilled the

gas partakes more or less of the nature of a liquid, and exhibits certain deviations from Boyle's law (181). This is the case with all gases; to a very slight extent with the less easily condensable gases, but to a far greater extent with vapours and the more condensable gases, especially near their points of liquefaction. These are now explained by the modification which Van der Waals has introduced into the equation for gases (183).

295. **Dynamical theory of gases.**—We have seen that in the gaseous condition the particles are assumed to fly about in right lines in all possible directions. A rough illustration of this condition of matter is afforded by imagining the case of a number of bees enclosed in a box.

Let us suppose a cubical vessel to be filled with air under standard conditions of temperature and pressure. Let the length of the sides be a . We will for the present suppose that each particle moves freely in the space without striking against another particle. All possible motions may be conceived to be resolved into motions in three directions which are parallel to the faces of the cube. Conceive any single particle of mass, m ; it will strike against one face with such a velocity, u , as not only to annul its own motion, but to cause it to rebound in the opposite direction with the same velocity; hence the measure of the force with which it strikes against the side will be $2mu$. Now, by their rapid succession and their uniform distribution, the total action of these separate impacts is to produce a pressure against the sides of the vessel which is the elastic force of the gas; and, to measure the pressure on the side, we must multiply the force of each individual impact by the total number of such impacts.

Since the length of the side is a , if there are n molecules in the unit of space, there will be na^3 in the volume of the cube, of which $\frac{na^3}{3}$ will be moving in a direction parallel to each one of the sides. To get the number of impacts on one face, we must remember that they succeed each other, after the interval of time required for a particle to fly to the opposite side and back again. Hence, u being the velocity, the number of impacts which each particle makes in the unit of time, a second, will be $\frac{u}{2a}$, and the number of all such which strike against one side will be $\frac{1}{3}na^3 \frac{u}{2a} = \frac{1}{6}na^2u$.

Now, since each one exerts a pressure represented by $2mu$, we shall have for the force exerted on the surface a^2

$$p a^2 = \frac{1}{3} a^2 n m u^2,$$

and therefore the pressure or the force per unit of surface will be

$$p = \frac{1}{3} n m u^2.$$

Again, if N is the number of molecules in the volume v , $N = nv$, and therefore

$$p = \frac{1}{3} \frac{N}{v} m u^2; \text{ that is, } p v = \frac{1}{3} N m u^2.$$

But, for any given mass of gas at constant temperature, N , m , and u are constant quantities, and the product $p v$ must therefore also be constant: this, however, is only one form of expressing Boyle's law (181).

We may put the above expression in the form $p\nu = \frac{2}{3}N\frac{mu^2}{2}$, so that for equal volumes of two different gases under the same conditions of temperature and pressure $\frac{2}{3}N\frac{mu^2}{2} = \frac{2}{3}N'\frac{M_1u_1^2}{2}$. The latter part of the expression represents the energy of the gas in each case. But under the conditions stated these are equal; accordingly we have $N = N'$, that is to say that equal volumes of two different gases under the same conditions of temperature and pressure contain the same number of molecules. This, which is known as *Avogadro's law*, was deduced by him from other considerations, and forms one of the most important bases of theoretical chemistry.

296. **Molecular velocity.**—In the formula $p = \frac{1}{3}nmv^2$, nm represents the mass in unit volume which we may designate as the density, ρ , of the gas, and which can be directly measured; and, since the pressure p is also capable of direct measurement, we can calculate the third magnitude u in absolute measure.

The pressure p on a gas is equal to the action of gravity on a column of mercury of given height, h ; so that, if δ is the density of mercury = 13·596, and g the acceleration of gravity, $p = \delta gh$ and

$$u^2 = \frac{3\delta gh}{\rho}.$$

Now, if σ be the specific gravity of the gas as compared with air, which is $\frac{1}{773\cdot3}$ lighter than water, $\rho \times 773\cdot3 = \sigma$, or $\rho = \frac{\sigma}{773\cdot3}$,

$$u^2 = \frac{3 \times 13\cdot596 \times 0\cdot76 \times 9\cdot8115 \times 773\cdot3}{\sigma},$$

which gives $u = \sqrt{\frac{485}{\sigma}}$; that is, that for atmospheric air be the mean velocity of the particles is 485 metres in a second. For other gases we have, expressed in the same units, O = 461, N = 492, H = 1844.

It follows from the above equation that

$$u : u_1 = \sqrt{\sigma_1} : \sqrt{\sigma};$$

that is, that *the molecular velocities are inversely as the square roots of the densities or the molecular weights*. This is confirmed by experiments on diffusion (191).

In a gas the velocities of the particles are unequal; since, even supposing that they were all originally the same, it is not difficult to see that they would soon alter. For imagine a particle to be moving parallel to one side, and to be struck centrally by another moving at right angles to the direction of its motion; the particle struck would proceed on its new path with increased velocity, while the striking particle would rebound in a different direction with a smaller velocity.

Notwithstanding the accidental character of the velocity of any individual particle in such a mass of gas as we have been considering, there will, at any one given time, be a certain average distribution of velocities. Now, from considerations based on the theory of probabilities, Maxwell inferred that

some velocities will be more probable than others—that there will, indeed, be one velocity which is more probable than any other. This is called the *most probable velocity*. The *mean velocity* of the particle, as deduced above, is not this, nor is it the same as the arithmetical mean of all the velocities; it may be defined to be that velocity which, if all the molecules possessed it, would give rise to the same mean energy of the molecular impacts against the side as that which actually exists. This mean velocity is about $\frac{1}{2}$ greater than the arithmetical mean velocity, and is $\frac{2}{3}$ that of the most probable single velocity.

Theoretical as well as experimental observations render it possible to determine with great probability the length of the path which one molecule of a gas traverses before it encounters another, which is known as the *free path*. This is not a constant number in one and the same gas; that is, the paths which the molecules travel between two impacts are not equal, and the average of these is known as the *mean free path*. The length of this depends on the number of molecules in unit volume of a gas, being inversely as the density; for it is obvious that as the density increases the number of molecules increases also, and therewith the path which one molecule travels before it meets another will be so much the smaller. The mean free path in different gases will be shorter the larger are the molecules. In nitrogen measured under standard conditions it has been determined to be $98.6 \mu\mu$ (micromillimetres), in hydrogen $185.5 \mu\mu$, and in carbonic acid $68 \mu\mu$. The frequency of the impacts has also been determined; in the case of hydrogen this is 9480 millions, and of nitrogen and air 8000 millions per second.

It has been urged against the kinetic theory of gases that with its enormous molecular velocity the diffusion of a gas with another ought to take place instantaneously, and be at once perceived in the case of those with strong odours; this, as we know, is not the case; the velocity is the rate between successive impacts, and billions of such impacts must take place before a molecule passes to any great distance.

The magnitudes of the molecules themselves have been calculated by several observers from different methods based on various physical phenomena (3). Loschmidt found, for instance, that the diameter of the molecule of hydrogen was $4.1 \mu\mu$, oxygen $0.7 \mu\mu$, and nitrogen $0.8 \mu\mu$. The results of other estimates, made by various methods, agree remarkably with these.

297. **General effects of heat.**—The general effects of heat upon bodies may be classed under three heads. One portion is expended in raising the temperature of a body; that is, in increasing the kinetic energy of its molecules. A second portion of the heat communicated to a body may be spent in altering the relative positions of the atoms within the molecule. These two effects are classed as *internal work*. The third portion is spent in increasing the volume, and so doing work against external pressure. The heat or work required for this is called the *external work*.

298. **Expansion.**—Nearly all bodies expand when heated. As a general rule, gases are the most expansible, then liquids, and lastly solids.

In solids which have definite figures, we can consider the expansion either in one dimension, the *linear* expansion; in two dimensions, the *superficial* expansion; or in three dimensions, the *cubical* expansion or the expansion of volume, although one of these never takes place without the

other. As liquids and gases have no definite figures, the expansions of volume have in them alone to be considered.

To show the linear expansion of solids, the apparatus represented in fig. 298 may be used. A metal rod, A, is fixed at one end by a screw, B,



Fig. 298

while the other end presses against the short arm of an index, K, which moves on a scale. Below the rod there is a sort of cylindrical lamp in which alcohol is burned. The needle K is at the first at zero point, but as the rod becomes heated it expands, and moves the needle along the scale.

The cubical expansion of solids is shown by a *Gravesande's ring*. This consists of a brass ball, *a* (fig. 299), which at the ordinary temperature passes

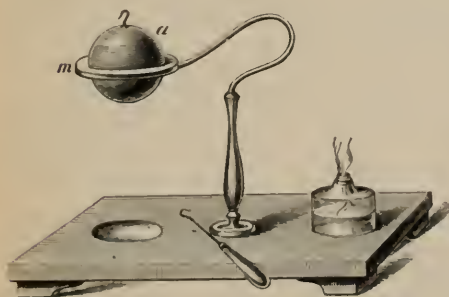

Fig. 299

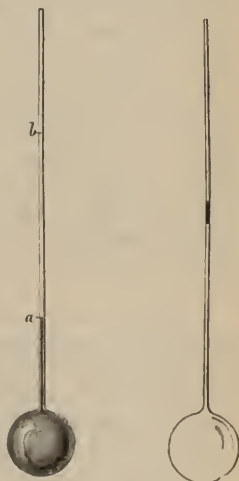

Fig. 300

Fig. 301

freely through a ring, *m*, almost of the same diameter. But when the ball has been heated, it expands, and no longer passes through the ring.

In order to show the expansion of liquids, a large glass bulb provided with a capillary stem is used (fig. 300). If the bulb and a part of the stem contain some coloured liquid, the liquid rapidly rises in the stem when heat

is applied, and the expansion thus observed is far greater than in the case of solids.

The same apparatus may be used for showing the expansion of gases. The bulb being filled with air, a small thread of mercury is introduced into the capillary tube to serve as index (fig. 301). When the globe is even slightly heated, for instance, by approaching the hand, the expansion is so great that the index is driven to the end of the tube, and is finally expelled. It is thus seen that gases are highly expansible.

In these different experiments the bodies contract on cooling, and when they have attained their former temperature they resume their original volume. Certain metals, however, especially zinc, form an exception to this rule, as do also some kinds of glass.

MEASUREMENT OF TEMPERATURE. THERMOMETRY

299. **Temperature.**—The *temperature* or *hotness* of a body may be defined, independently of any hypothesis as to the nature of heat, as being a quality of the body depending on the greater or less extent to which it tends to impart sensible heat to other bodies. The *temperature* of a body must not be confounded with the quantity of *heat* it possesses: a body may have a high temperature and yet have a very small quantity of heat, and, conversely, a low temperature and yet possess a large amount of heat. If a cup of water is taken from a bucketful, both will have the same temperature, yet the quantities of heat they possess will be different. This subject of the quantity of heat will be afterwards more fully explained in the chapter on Specific Heat.

300. **Thermometers.**—*Thermometers* are instruments for measuring temperature. Owing to the imperfections of our senses, we are unable to measure temperatures by the sensation of heat or cold which they produce in us, and hence recourse must be had to the physical actions of heat on bodies. These actions are of various kinds, but the expansion of bodies has been selected as the easiest to observe. Heat also produces electric phenomena in bodies; and on these the most delicate methods of observing temperatures have been based, as we shall see in a subsequent chapter.

Liquids are best suited for the construction of thermometers—the expansion of solids being too small, and that of gases complicated by variations of pressure. Mercury and alcohol are the only liquids used—the former because it boils at a moderately high temperature, and the latter because it requires an extremely low temperature for its solidification.

The mercury thermometer is the most extensively used. It consists of a capillary glass tube, at the end of which is blown the *bulb*, a cylindrical or spherical reservoir. Both the bulb and a part of the stem are filled with mercury, and the expansion is measured by a scale graduated either on the stem itself or on a frame to which the stem is attached.

Besides the manufacture of the bulb, the construction of the thermometer comprises three operations: the calibration of the tube, to test the uniformity of its bore; the introduction of the mercury into the reservoir; and the graduation.

301. **Division of the tube into parts of equal capacity. Calibration.**—As the indications of the thermometer are only correct when the divisions of the scale correspond to equal expansions of the mercury in the reservoir, the scale must be graduated, so as to indicate parts of equal capacity in the tube. If the tube were of the same diameter throughout, it would only be necessary to divide it into equal lengths. But as the diameter of glass tubes is usually greater at one end than another, parts of equal capacity in the tube are represented by unequal lengths of the scale.

In order, therefore, to select a tube of uniform bore, the tube is *calibrated*; for this purpose, a thread of mercury about an inch long is introduced into the capillary tube, and moved to different positions in the tube, care being taken to keep it at the same temperature. If the thread is of the same length in every part of the tube, the capacity is everywhere the same; but if the thread occupies different lengths in different parts, the tube is rejected, and another one sought.

302. **Filling the thermometer.**—In order to fill the thermometer with mercury, a small funnel, C (fig. 302), is blown on the top, and is filled with mercury; the tube is then slightly inclined, and the air in the bulb expanded by heating it with a spirit lamp. The expanded air partially escapes by the funnel, and, on cooling, the air which remains contracts, and a portion of the mercury passes into the bulb, D. The bulb is then again warmed, and allowed to cool, a fresh quantity of mercury enters, and so on, until the bulb and part of the tube are full of mercury. The mercury is then heated to boiling; the mercury vapour in escaping carries with it the air and moisture which remain in the tube. The tube, being full of the expanded mercury and of mercury vapour, is hermetically sealed at one end. When the thermometer is cold, the mercury ought to fill the bulb and a portion of the stem.



Fig. 302

303. **Determination of the fixed points and graduation of the thermometer.**—Experiment has shown that ice constantly melts at the same temperature, whatever be the source of heat, and that distilled water under the same pressure and in a given vessel always boils at the same temperature. These two temperatures therefore, that of melting ice, and that of water boiling under a pressure of 76 cm. of mercury, may be taken as fixed points of reference for the thermometer stem.

To obtain the lower fixed point snow or pounded ice is placed in a vessel (fig. 303). The bulb and a part of the stem of the thermometer are immersed in this for about a quarter of an hour, and a mark made at the level of the mercury, which represents the point required.

The second fixed point is determined by means of an apparatus of which fig. 304 represents a vertical section. A central tube, B, open at both

ends, is fixed on a cylindrical vessel containing water; a second tube, C, concentric with the first, and surrounding it, is fixed on the same vessel, A. In this second cylinder, which is closed at both ends, there are three tubulures, a , r , r' . A cork, in which is the thermometer, fits in a . To r' , a glass tube, containing mercury, is attached, which serves as a manometer for measuring the pressure of the vapour in the apparatus; r is an escape tube for the vapour and condensed water.

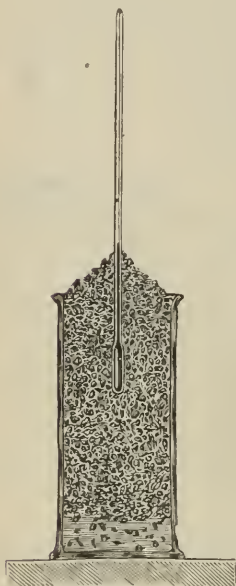

Fig. 303

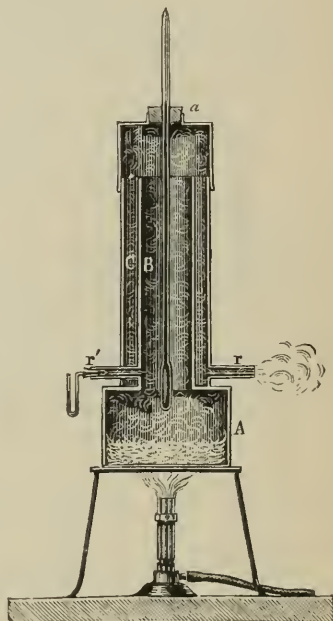

Fig. 304

The apparatus is heated over a flame till the water boils; the vapour produced in A rises in the tube B, and, passing through the outside tube, escapes by r . The thermometer being thus surrounded with vapour, the mercury expands, and when the top of the mercurial column has become stationary, the point at which it stops is marked. This is the point sought for. The object of the outer case, C, is to avoid the cooling of the inner tube by its contact with the air.

The determination of the point 100 (see next article) would seem to require that the height of the barometer during the experiment should be 760 millimetres, for, when the barometric height is greater or less than this quantity, water boils either above or below 100 degrees. But the point 100 may always be exactly obtained by making a suitable correction. For every 27 millimetres difference in height of the barometer there is a difference in the boiling point of 1 degree. If, for example, the height of the barometer is 778—that is, 18 millimetres, or two-thirds of 27, above 760—

water would boil at 100 degrees and two-thirds. Consequently $100\frac{2}{3}$ would have to be marked at the point at which the mercury stops.

Gay-Lussac observed that water boils at a somewhat higher temperature in a glass than in a metal vessel; and as the boiling point is raised by any salts which are dissolved, it has been assumed that it was necessary to use a metal vessel and distilled water in fixing the boiling point. Rudberg showed, however, that these latter precautions are superfluous. The nature of the vessel and salts dissolved in ordinary water affect the temperature of boiling water, but not that of the vapour which is formed. That is to say, that if the temperature of boiling water from any of the above causes is higher than 100 degrees, the temperature of the vapour does not exceed 100, provided the pressure is not more than 760 millimetres. Consequently, the higher point may be determined in a vessel of any material, when the thermometer is quite surrounded by vapour, and does not dip in the water.

Even with distilled water the bulb of the thermometer must not dip in the liquid; for, strictly speaking, it is only the upper layer that really has the temperature of 100 degrees, since the temperature increases from layer to layer towards the bottom, in consequence of the increased pressure.

304. **Construction of the scale.**—Just as the foot-rule which is adopted as the unit of comparison for length is divided into a number of equal divisions called inches for the purpose of providing a smaller unit of comparison, so likewise the unit of comparison of temperatures, the range from the melting point to the boiling point, must be divided into a number of parts of equal capacity called *degrees*. On the Continent, and more especially in France, this space is divided into 100 parts, the lower fixed point being marked 0 and the upper 100, and this division is called the *Centigrade* or *Celsius* scale; Celsius, its inventor, died in 1742. The Centigrade thermometer is almost exclusively adopted in foreign scientific works, and, as its use is gradually extending in this country, it has been and will be adopted in this book.

The degrees are designated by a small cipher placed a little above on the right of the number which marks the temperature, and to indicate temperatures below zero the minus sign is placed before them. Thus, -15 signifies 15 degrees below zero.

In accurate thermometers the scale is marked on the stem itself (fig. 305). It cannot be displaced, and its length remains fixed, as glass has very little expansibility. The graduation is effected by covering the stem with a thin layer of wax, and then marking the divisions of the scale, as well as the corresponding numbers, with a steel point. The thermometer is then exposed for about ten minutes to the vapours of hydrofluoric acid, which attacks the glass where the wax has been removed. The stem is thus permanently etched.

Besides the *Centigrade* scale two others are frequently used—*Fahrenheit's scale* and *Réaumur's scale*.

In Réaumur's scale the fixed points are the same as on the Centigrade



Fig. 305

scale, but the distance between them is divided into 80 degrees, instead of into 100. That is to say, 80 degrees Réaumur are equal to 100 degrees Centigrade; 1 degree Réaumur is equal to $\frac{100}{80}$ or $\frac{5}{4}$ of a degree Centigrade, and 1 degree Centigrade equals $\frac{80}{100}$ or $\frac{4}{5}$ degree Réaumur. Consequently, to convert any number of Réaumur's degrees into Centigrade degrees (20, for example), it is merely necessary to multiply them by $\frac{5}{4}$ (which gives 25). Similarly, Centigrade degrees are converted into Réaumur by multiplying them by $\frac{4}{5}$.

The thermometric scale invented by Fahrenheit in 1714 is still much used in England, and also in Holland and North America. The higher fixed point is, like that of the other scales, the temperature of boiling water; but the null point of zero is the temperature obtained by mixing equal weights of sal-ammoniac and snow, and the interval between the two points is divided into 212 degrees. The zero was selected because the temperature was the lowest then known, and was thought to represent absolute cold. When Fahrenheit's thermometer is placed in melting ice it stands at 32 degrees, and therefore 100 degrees on the Centigrade scale are equal to 180 degrees on the Fahrenheit scale, and thus 1 degree Centigrade is equal to $\frac{9}{5}$ of a degree Fahrenheit, and, conversely, 1 degree Fahrenheit is equal to $\frac{5}{9}$ of a degree Centigrade.

Since the distance on the thermometer stem between boiling point and freezing point is divided into 180, 100, and 80 equal parts respectively on the Fahrenheit, Centigrade, and Réaumur scales, it is clear that 9 degrees Fahrenheit = 5 degrees Centigrade = 4 degrees Réaumur. Hence, since on the two latter scales the graduations begin from the freezing point and on the Fahrenheit scale from a point 32 degrees below the freezing point, if F, C, and R represent the same temperature on the different scales,

$$\frac{F - 32}{9} = \frac{C}{5} = \frac{R}{4}$$

305. **Displacement of zero.**—Thermometers, even when constructed with the greatest care, are subject to a source of error which must be taken into account; this is, that in course of time the zero tends to rise, the displacement sometimes extending to as much as 2 degrees; so that when the thermometer is immersed in melting ice the mercury no longer sinks to zero.

This is generally attributed to a diminution of the volume of the bulb and also of the stem, occasioned by the pressure of the atmosphere. It is usual with very accurate thermometers to fill them two or three years before they are graduated. Joule once observed that even after twenty-five years a delicate thermometer indicated a displacement of zero.

Besides this slow displacement, there are often variations in the position of the zero, when the thermometer has been exposed to temperatures above 60°, caused by the fact that the bulb and stem do not immediately contract on cooling to their original volume; these differences are greater the thicker the glass sides, and hence it is necessary from time to time to verify the position of zero when a thermometer is used for accurate determinations.

Regnault noticed that some mercury thermometers, which agree at 0° and at 100°, differ between these points, and he ascribed this to the unequal expansion of different kinds of glass.

According to Pfaundler the difference due to this cause is scarcely 0.2 of a degree between 0° and 100° , while at 350° it may be as much as 10 degrees.

306. **Limits to the employment of mercury thermometers.**—Of all thermometers in which liquids are used, the one with mercury is the most useful, because this liquid is easily obtained pure and expands very regularly between -36° and 100° ; that is, proportionally to the rise of temperature. It also has the advantage of having a very low specific heat. But for temperatures below -36° C. the alcohol thermometer must be used, since mercury solidifies at -39° C. Above 100 degrees the coefficient of expansion increases, and the indications of the mercury thermometer are only approximately correct, the error rising sometimes to several degrees. Mercury thermometers cannot be used for temperatures above 350° , for this is the boiling point of mercury.

For very accurate measurements the air thermometer is used (336).

307. **Alcohol thermometer.**—The *alcohol thermometer* differs from the mercury thermometer in being filled with coloured alcohol, and in having a tube of larger calibre. The method of filling an alcohol thermometer is similar to that already described for mercury thermometers. When the bulb and tube have been filled to the requisite height, the end of the tube is sealed by the blowpipe, but no attempt is made to get rid of the air in the tube. On the contrary, it is an advantage to have air in the tube at somewhat greater than atmospheric pressure, as the alcohol column is thus prevented from breaking up into short cylinders separated by vapour. Alcohol thermometers, after 0° C. has been obtained by melting ice, are usually graduated by placing them in baths at different temperatures together with a standard mercury thermometer, and marking on the alcohol thermometer the temperature indicated by the mercury thermometer. In this manner the alcohol thermometer is made comparable with the mercury one; that is to say, it indicates the same temperatures under the same conditions. The alcohol thermometer is especially used for low temperatures, as alcohol only freezes at -130° C.

308. **Conditions of delicacy of a thermometer.**—A thermometer may be delicate in two ways:—1. When it indicates very small changes of temperature. 2. When it quickly assumes the temperature of the surrounding medium.

The first kind of delicacy is attained by having a very narrow capillary tube and a very large bulb; the expansion of the mercury on the stem is then limited to a small number of degrees, from 10 to 20 or 20 to 30 for instance, so that each degree occupies a great length on the stem, and can be subdivided into very small fractions. The second kind of delicacy is obtained by making the bulb very small, for then it rapidly assumes the temperature of the liquid in which it is placed.

A good mercury thermometer should answer to the following tests:—When its bulb and stem, to the top of the column of mercury, are immersed in melting ice, the top of the mercury should exactly indicate 0° C.; and when suspended with its bulb and scale immersed in the steam of water boiling in a metal vessel (as in fig. 304), the barometer standing at 760 mm., the mercury should be stationary at 100° C. The value of the degrees should be uniform; to ascertain this a little cylinder of mercury may be

detached from the column by a slight jerk, and on inclining the tube it may be made to pass from one portion of the bore to another. If the scale be properly graduated and the tube be of uniform bore, the column will occupy an equal number of degrees in all parts of the tube.

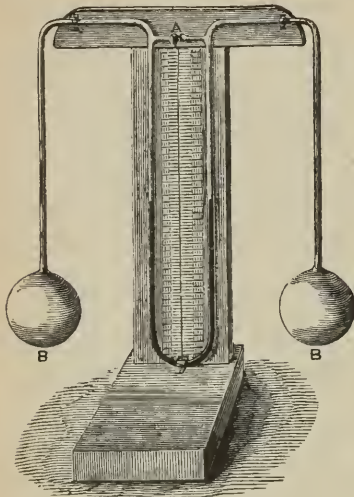

Fig. 306

309. **Differential thermometer.**—Sir John Leslie constructed a thermometer for showing the difference of temperature of two neighbouring places, from which it has received the name of the *differential thermometer*.

A modified form of it is that devised by Matthiessen (fig. 306), which has the advantage of being available for indicating the temperature of liquids. It consists of a bent glass tube, each end of which is bent twice, and terminates in a bulb; the bulbs being pendent can be readily immersed in two different liquids. The bend contains some coloured liquid, and in a tube which connects the two limbs is a stop-cock, by which the liquid in each limb is easily brought to the same level. The whole is supported by a frame.

When one of the bulbs is at a higher temperature than the other, the liquid in the stem is depressed and rises in the other stem. The instrument is now only used as a *thermoscope*; that is, to indicate a difference of temperature between the two bulbs, and not to measure its amount.

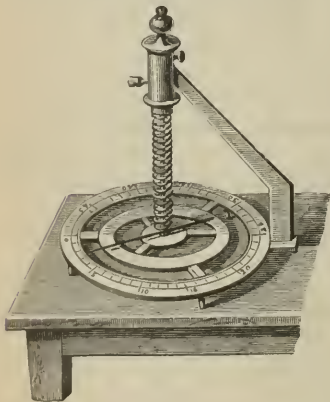

Fig. 307

310. **Breguet's metallic thermometer.** Breguet invented a thermometer of considerable delicacy, which depends on the unequal expansion of metals. It consists of three strips, of platinum, gold, and silver, which are passed through a rolling mill so as to form a very thin metallic ribbon. This is then coiled in a spiral form, as seen in fig. 307, and, one end being fixed to a support, a light needle is fixed to the other, which

is free to move round a graduated scale.

Silver, which is the most expansible of the metals, forms the inner face of the spiral, and platinum the outer. When the temperature rises, the silver expands more than the gold or platinum, the spiral unwinds itself, and the needle moves from left to right of the above figure. The contrary

effect is produced when the temperature sinks. The gold is placed between the other two metals because its expansibility is intermediate between that of the silver and that of the platinum. Were these two metals employed alone, their rapid unequal expansion might cause a fracture. Breguet's thermometer is empirically graduated in Centigrade degrees, by comparing its indications with those of a standard mercury thermometer.

Several forms of pocket thermometers depend on this principle, which is also applied in some registering thermometers.

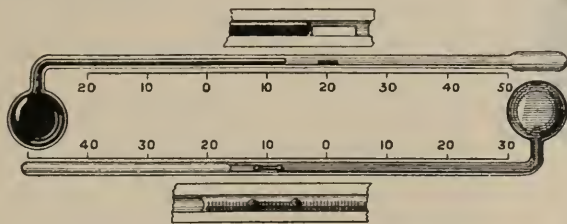

Fig. 308

311. **Maximum and minimum thermometers.**—It is necessary, in meteorological observations, to know the highest temperature of the day and the lowest temperature of the night. Ordinary thermometers could only give these indications by a continuous observation, which would be impracticable. Several instruments have accordingly been invented for this purpose, the simplest of which is Rutherford's. On a rectangular piece of plate-glass (fig. 308) two thermometers are fixed, whose stems are bent horizontally. The upper one is a mercury, and the lower an alcohol thermometer. In the maximum thermometer there is a small piece of iron wire or hard wood moving freely in the tube, and serving as an index. The thermometer being placed horizontally, the mercury pushes the index before it when the temperature rises. But when the temperature falls and the mercury contracts, the index retains that position in the tube to which it has been moved, for there is no adhesion between the iron and the mercury. In this way the index registers the highest temperature which has been attained. In the minimum thermometer alcohol is the liquid employed; the index is a small piece of glass, shaped like a dumb-bell, which is placed *in* the liquid. When the temperature falls the convex side of the liquid meniscus carries the index with it; when the temperature rises the liquid passes by the index without disturbing it; the position of the index gives therefore the lowest temperature which has been reached.

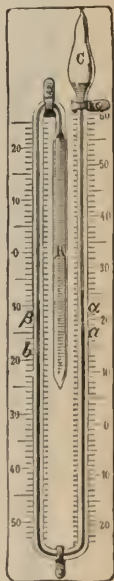

Fig. 309

Sixe's thermometer (fig. 309) is not only a maximum and minimum, but gives a double reading and therefore corrects itself. It consists of a U-shaped glass tube which is bent round at one extremity and terminates in a long cylindrical bulb, B. At the other end of the U tube is a conical bulb, C. The bend of the tube from *a* to *b* contains mercury.

Alcohol occupies the bulb B and extends as far as to the top of the mercury b ; above a , again, is alcohol which occupies a portion of the bulb C.

The rest of C contains air and alcohol vapour. The liquid—alcohol, mercury, alcohol—is thus continuous from the surface in C to the other end of the system.

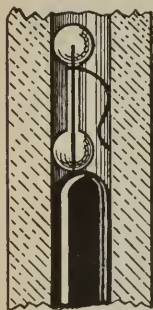

Fig. 310

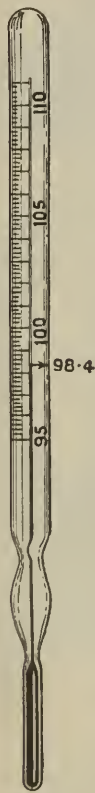

Fig. 311

When the temperature rises, the alcohol in B expands and pushes the mercury down at b and up at a , and the mercury in its turn drives the alcohol towards the bulb C, in which the air is compressed and the alcohol vapour partially condensed. When the temperature falls, the alcohol in B contracts, but in consequence of the pressure exerted by the air in C, no break occurs in the liquid column, the mercury at b following the receding alcohol. In the alcohol columns, above a and b , are indexes consisting either of iron wire, or of fine glass tubing in which an iron wire is sealed; and to each index a short piece of horsehair is fastened (fig. 310). When the temperature rises the index a is pushed up, and remains in position owing to the friction of the horsehair. Similarly, when the temperature falls the index β is pushed forward and marks the minimum temperature. The setting of the indexes is effected by a magnet.

In *Negretti's maximum thermometer* the tube near the bulb is nearly throttled, the result of which is, that although during a rise of temperature the mercury is continuous from the bulb to the end of the column, as soon as the mercury begins to contract by reason of fall of temperature, the mercury column is broken at the constriction. Thus, a thread of mercury is left in the tube and indicates the highest temperature reached. This thread contracts to a small extent as the temperature falls, but the chief contraction takes place in the bulb.

The *clinical thermometer* (fig. 311)—used by physicians for determining the temperature of the body—is generally constructed on the Negretti principle. It is graduated from 90° F. to 110° , the normal temperature of the healthy body being 98.4° . To be reset the instrument must be held in the hand and sharply jerked. The momentum of the mercury can thus be made to overcome the friction at the constriction, and continuity is re-established between the mercury in the tube and that in the bulb.

312. **Pyrometers.**—The name *pyrometers* is given to instruments for measuring temperatures so high that mercurial thermometers could not be used. The older contrivances for this purpose—Wedgwood's, Daniell's (which in principle resembled the apparatus in fig. 298), Brongniart's, &c.—have gone entirely out of use. None of them give an exact measure of temperature. The arrangements now used

for the purpose are based either on the expansion of gases and vapours, on the specific heat of solids, or on the electric properties of bodies, and will be subsequently described.

313. **Different remarkable temperatures.**—The following table gives some of the most remarkable points of temperature. It may be observed that it is easier to produce very high than very low temperatures.

Liquid nitrogen boils	- 194° C.
Liquid oxygen boils	- 183
Greatest natural cold recorded in Arctic expeditions	- 58·7
Mercury freezes	- 38·9
Mixture of snow and salt about	- 20
Ice melts	0
Greatest density of water	+ 4
Mean temperature of London	9·9
Temperature of the blood	36·9
Water boils	100
Highest temperature of a Turkish bath	125
Mercury boils	357
Sulphur boils	444
Red heat (just visible) about	500
Silver melts	954
Zinc boils	960
Cast iron melts about	1200
Platinum melts	1775
Iridium melts	1950

CHAPTER II

EXPANSION OF SOLIDS

314. **Linear, superficial, and cubical expansion.** Coefficients of expansion.—It has been already explained that in solid bodies the expansion may be considered either in one or two or three dimensions—linear, superficial, or cubical.

The *coefficient of linear expansion* is the increase of the unit of length of a body when its temperature rises from zero to 1 degree C. ; the *coefficient of superficial expansion* is the increase of the unit of surface when heated from zero to 1 degree, and the *coefficient of cubical expansion* is the increase of the unit of volume under the same circumstances.

These coefficients vary with different bodies, but for the same body the *coefficient of cubical expansion is three times that of the linear expansion*, as is seen from the following considerations:—Suppose a cube the length of whose side is 1 at zero. Let k be the elongation of this side in passing from zero to 1 degree, its length at 1 degree will be $1+k$, and the volume of the cube which was 1 at zero will be $(1+k)^3$, or $1+3k+3k^2+k^3$. But as the elongation k is always a very small fraction (see table, art. 318), its square, k^2 , and still more its cube, k^3 , are so small that they may be neglected, and the value at 1 degree becomes very nearly $1+3k$. Consequently, the increase of volume is $3k$, or the coefficient of cubical expansion is thrice the coefficient of linear expansion.

In the same manner it may be shown that the coefficient of superficial expansion is double the coefficient of linear expansion.

315. **Measurement of the coefficient of linear expansion.** Lavoisier and Laplace's method.—The apparatus used by Lavoisier and Laplace for determining the coefficients of linear expansion (fig. 312) consists of a brass

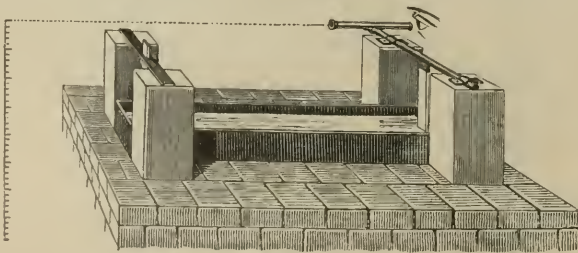

Fig. 312

trough, placed on a furnace between four stone supports. On the two supports on the right hand there is a horizontal axis at the end of which is a

telescope ; on the middle of this axis, and at right angles to it, is fixed a glass rod, turning with it, as does also the telescope. The other two supports are joined by a cross-piece of iron, to which another glass rod is fixed, also at right angles. The trough, which contains oil or water, is heated by a furnace not represented in the figure, and the bar whose expansion is to be determined is placed in it.

Fig. 313 represents a section of the apparatus ; G is the telescope, KH the bar, whose ends press against the two glass rods F and D. As the rod F is fixed, the bar can only expand in the direction KH, and in order to eliminate the effects of friction it rests on two glass rollers. Lastly the telescope has a cross-wire in the eyepiece, which, when the telescope moves, indicates the depression by the corresponding number of divisions on a vertical scale, AB, at a distance of 220 yards.

The trough is first filled with ice, and the bar being at zero, the division on the scale AB, corresponding to the wire of the telescope, is read off. The ice having been removed, the trough is filled with oil or water, which is heated to a given temperature. The bar then expands, and when its temperature, as indicated by thermometers in the bath, has become stationary, the division of the scale, seen through the telescope, is read off.

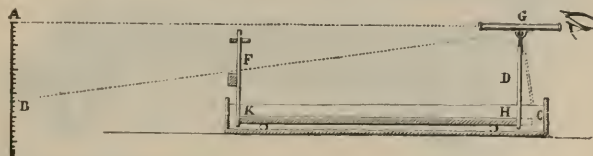

Fig. 313

From these data the elongation of the bar is determined ; for since it has become longer by a quantity, CH, and the optical axis of the telescope has become inclined in the direction GB, the two triangles, GHC and ABG, are similar, for they have the sides at right angles each to each, so that $\frac{HC}{AB} = \frac{GH}{AG}$. A preliminary measurement showed $\frac{GH}{AG}$ to be $\frac{1}{744}$. Conse-

quently, $\frac{HC}{AB} = \frac{1}{744}$, whence $HC = \frac{AB}{744}$; that is, the total elongation of the bar is obtained by dividing the length on the scale traversed by the cross-wire by 744. Dividing this elongation by the length of the bar, and then by the temperature of the bath, the quotient is the dilatation for the unit of length and for a single degree—in other words, the mean coefficient of linear expansion between 0° and 100° .

316. **Roy and Ramsden's method.**—Lavoisier and Laplace's method is founded on an artifice which is frequently adopted in physical determinations, and which consists in amplifying by a known amount dimensions which, in themselves, are too small to be easily measured. Unfortunately, this plan is often more fallacious than profitable, for it is first necessary to determine the ratio of the motion measured to that on which it depends. In the present case, it is necessary to know the lengths of the arms of the lever in the apparatus. But this preliminary operation may introduce errors of such

importance as partially to counterbalance the advantage of great delicacy. The following method, devised by Ramsden and used by General Roy in 1787, depends on another principle. It measures the elongations directly, and without amplifying them; and it does so by means of a micrometer arrangement, which indicates very small displacements.

The apparatus (fig. 314) consists of three parallel metal troughs about 6 feet long. In the middle one there is a bar of the material whose expansion is to be determined, and in the two others are cast-iron bars of exactly the same length as this bar. Rods are fixed vertically on both ends of these

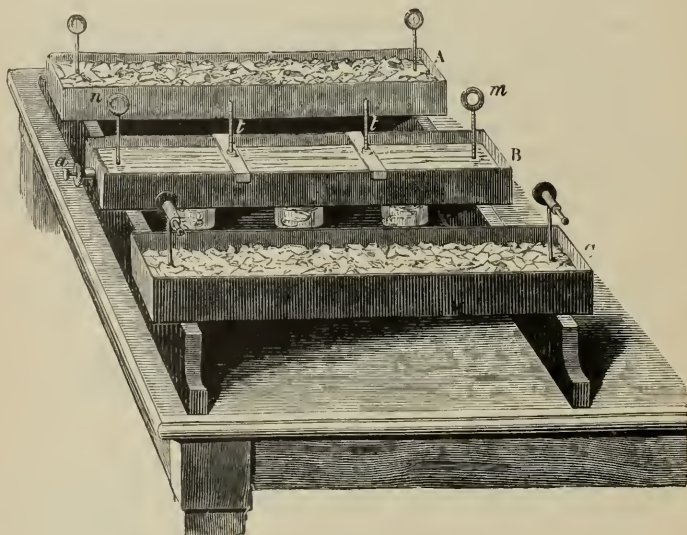

Fig. 314

three bars. On the rods in the trough A there are rings with cross-wires like those of a telescope. The rods in the trough B carry the object-glasses of telescopes of which the eyepieces and cross-wires are in the tubes on the rods in C.

The troughs being filled with ice, and all three bars at zero, the points of intersection of the wires in the rings and of the wires in the telescope are in a line at each end of the bar. The temperature in the middle trough is then raised to 100° C. by means of spirit lamps placed beneath the trough; the bar expands, but as it is in contact with the end of the screw, *a*, fixed on the side, all the elongation takes place in the direction *mm*, and, as the lens *n* remains in position, the lens *m* is moved towards B by a quantity equal to the elongation. But since the screw *a* is attached to the bar, when it is turned slowly from right to left, the bar is moved in the direction *mm* until the observer looking through the tube in C sees distinctly the cross-wires in A in coincidence with those in the eyepiece. The distance through which *m* has been moved is equal to the elongation of the bar, and this is deduced from the number of turns of the screw *a*, when the thread of the screw is

once known. Thus the total expansion of the bar is obtained, which, divided by the temperature of the bath, and by the length of the bar at zero, gives the coefficient of linear expansion.

317. **Coefficients of linear expansion.**—By one or the other method the following results have been obtained :—

Mean coefficients of linear expansion for 1° between 0° and 100° C.

Quartz (between 0° and 1000°)	0·00000059	Copper	0·000017182
Diamond	0·000001180	Bronze	0·000018167
Pine	0·000006080	Brass	0·000018782
Graphite	0·000007860	Silver	0·000019097
Marble	0·000008490	Tin	0·000021730
White glass	0·000008613	Aluminium	0·000023130
Platinum	0·000008842	Lead	0·000028575
Platinum (between 0° and 1000°)	0·00001015	Zinc	0·000029417
Untempered steel	0·000010788	Sodium chloride.	0·000040390
Cast iron	0·000011250	Ice	0·000054000
Sandstone	0·000011740	Sal ammoniac	0·000063000
Wrought iron	0·000012204	Sulphur	0·000064130
Tempered steel	0·000012395	Sodium	0·000072000
Gold	0·000014660	Ebonite (17° to 35°)	0·000080600
Nickel	0·000016	Potassium	0·000083000
		Paraffin	0·000278540
		Gutta-percha	0·000598000

The expansion of alloys of nickel and copper changes enormously with a comparatively small change in the proportion of the constituent metals. For example, the coefficient of expansion, an alloy containing 28 per cent. of nickel, is '000015 ; if the percentage of nickel rises to 36, the coefficient falls to '0000015 (one-tenth of the previous value), but rises again to '000012 when the proportion of nickel reaches 60 per cent. In consequence of its extremely small expansibility the alloy containing 36 per cent. nickel has received the special name *invar*. It is used for clock pendulums (321), and for standards of length in the determination of base lines in geodetic measurements. The alloy containing 45 per cent. nickel has the same coefficient of expansion as glass and platinum ; it can therefore be used as a substitute for platinum in glow lamps (865) and vacuum tubes (979).

In accordance with what has been said about the linear expansion (314), the coefficients of cubical expansion of solids are obtained by multiplying those of linear expansion by 3, and conversely those of linear expansion may be deduced from the cubical if we divide by 3.

The coefficients of expansion of the metals vary with their physical condition, being different for the same metal according as it has been cast or hammered and rolled, hardened or annealed. As a general rule, operations which increase the density increase also the rate of expansion. But even for substances in apparently the same condition, different observers have found very unequal amounts of expansion ; this may arise in the case of compound substances, such as glass, brass, or steel, from a want of

uniformity in chemical composition, and in simple bodies from slight differences of physical state.

The expansion of amorphous solids, and of those which crystallise in the regular system, is the same in all directions, unless they are subject to a strain in some particular direction. A fragment of such a substance varies in bulk when its temperature is changed, but retains the same shape. Crystals not belonging to the regular system when heated exhibit unequal expansions in the directions of their different axes, in consequence of which the magnitude of their angles, and therefore their form, is altered. In the dimetric system the expansion is the same in the direction of the two equal axes, but different in the third. In crystals belonging to the hexagonal system the expansion is the same in the direction of the three secondary axes, but different from that along the principal axis. In the trimetric system it is different in all three directions.

To the general law that all solid bodies expand by heat there is an important exception in the case of iodide of silver, which contracts somewhat when heated. Between -60° and $+142^{\circ}$ C. it has a negative coefficient of expansion, the value of which is 0.00000139 for 1° C.

Fizeau determined the expansion of a great number of crystallised bodies by an optical method. He placed thin plates of the substance on a glass plate and let yellow light pass through them. He thus obtained alternately yellow and dark Newton's rings (664). On rise of temperature, the plate of the substance expanded, the thin layer of air became thinner, and the position of the rings was altered. From the alteration in their position the amount of the expansion could be deduced. Among the results he has obtained is the curious one that certain crystallised bodies, such as diamond, emerald, and cuprous oxide, contract on being cooled to a certain temperature, but as the cooling is continued below this temperature they expand. They have thus a temperature of maximum density, as is the case with water (331). In the case of emerald and cuprous oxide this temperature is at -4.2° , in the case of diamond at -42.3° .

318. **The coefficients of expansion increase with the temperature.**—According to Matthiessen, who determined the expansion of some metals and alloys by weighing them in water at different temperatures, the coefficients of expansion are not quite regular between 0° and 100° . Some of his results are given below, the letters L_0 , L_t denoting the lengths of a bar of the metal at 0° and t° respectively.

Zinc	$L_t = L_0(1 + 0.00002741 t + 0.0000000235 t^2)$
Lead	$L_t = L_0(1 + 0.00002716 t + 0.0000000074 t^2)$
Silver	$L_t = L_0(1 + 0.00001809 t + 0.0000000135 t^2)$
Copper	$L_t = L_0(1 + 0.00001408 t + 0.0000000264 t^2)$
Gold	$L_t = L_0(1 + 0.00001358 t + 0.0000000112 t^2)$

Matthiessen further found that the coefficients of expansion of an alloy are very nearly equal to the mean of the coefficients of expansion of the volumes of the metals composing it.

319. **Formulæ relative to the expansion of solids.**—Let l_0 be the length of a bar at zero, l_t its length at the temperature t° C., and β its coefficient of linear expansion.

The elongation corresponding to t is t times β or βt for unit length, or $\beta t l_0$ for l_0 units. The length of the bar which is l_0 at zero is $l_0 + \beta t l_0$ at t , consequently

$$l_t = l_0 + \beta t l_0 = l_0(1 + \beta t).$$

This formula gives the relation between the four magnitudes l_0 , l_t , β , t , and it is clear that if any three of these are given we can determine the fourth.

The formulæ for cubical expansion are entirely analogous to the preceding.

The following are examples of the application of these formulæ:—

(i.) A metal bar has a length l' at t'° ; what will be its length l at t° ?

From the above formula we first get the length of the given bar at zero, which is $\frac{l'}{1 + \beta t'}$; by means of the same formula we pass from zero to t° in multiplying by $1 + \beta t$, which gives for the desired length

$$l = \frac{l'(1 + \beta t)}{1 + \beta t'}$$

(ii.) The density of a body being d at zero, required its density d' at t° .

If V be the volume of the body at zero, and D its coefficient of cubical expansion, the volume at t will be $V + Dt$; and as the density of a body is in inverse ratio of the volume which the body assumes in expanding, we get the inverse proportion,

$$\begin{aligned} d' : d &= 1 : 1 + Dt \\ \frac{d'}{d} &= \frac{1}{1 + Dt}; \text{ or } d' = \frac{d}{1 + Dt} \end{aligned}$$

Consequently, when a body is heated from 0 to t° , its density, and therefore its weight for an equal volume, is inversely as the expression $1 + Dt$.

320. Applications of the expansion of solids.—In the arts we meet with numerous examples of the influence of expansion. (i.) The bars of furnaces must not be fitted tightly at their extremities, but must, at least, be free at one end, otherwise in expanding they would split the masonry. (ii.) In making railways a small space is left between the successive rails, for, if they touched, the force of expansion would cause them to curve or would break the chairs. (iii.) Water-pipes are fitted to one another by means of telescope joints, which allow room for expansion. (iv.) If a glass vessel is heated or cooled too rapidly, it cracks, especially if it be thick; this arises from the fact that, since glass is a bad conductor of heat, the sides become unequally heated, and consequently unequally expanded, which causes a fracture. (v.) The cracking off of a portion of a glass tube by red-hot charcoal is due to the expansion of the heated parts, which detach themselves from the rest.

When bodies have been heated to a high temperature, the force produced by their contraction on cooling is very considerable; it is equal to the force which is needed to compress or expand the material to the same extent by mechanical means. According to Barlow, a bar of malleable iron a square inch in section is stretched $\frac{1}{10000}$ th of its length by a weight of a ton; the same increase is produced by a change of temperature of about

9° C. A difference of 45° C. between the cold of winter and the heat of summer is not infrequently experienced in this country. In that range, a wrought-iron bar ten inches long will vary in length by $\frac{1}{200}$ th of an inch, and will exert a stress, if its ends are securely fastened, of fifty tons. It has been calculated from Joule's data that the work done by heat in expanding a pound of iron between 0° and 100°, during which it increases about $\frac{1}{880}$ th of its bulk, is equal to 16,000 foot-pounds; that is, it could raise a weight of about 7 tons through a height of one foot.

An application of this contractile force is seen in the mode of securing tires on wheels. The tire being made red-hot, and thus considerably expanded, is placed on the circumference of the wheel and then cooled. The tire, when cold, embraces the wheel with such force as not only to secure itself on the rim but also to press home the joints of the spokes into the felloes and nave. Another interesting application was made in the case of a gallery at the Conservatoire des Arts et Métiers in Paris, the walls of which had begun to bulge outwards. Iron bars were passed across the building and screwed into plates on the outside of the walls. Each alternate bar was then heated by means of lamps, and when the bar had expanded it was screwed up. The bars, being then allowed to cool, contracted, and in so doing drew the walls together. The same operation was performed on the other bars.

321. **Compensation pendulum.**—An important application of the expansion of metals has been made in the *compensation pendulum*. This is a pendulum in which the elongation, when the temperature rises, is so compensated that the distance between the centre of suspension and the centre of oscillation (81) remains constant, a condition which, from the laws of the pendulum, is necessary for isochronous oscillations, and in order that the pendulum may be used as a regulator of clocks.

In fig. 315, which represents the *gridiron* pendulum, one of the forms of compensation pendulum, the ball L, instead of being supported by a single rod, is supported by a framework, consisting of alternate rods of steel and brass. In the figure the shaded rods represent steel; including a small steel rod, *b*, which supports the whole of the apparatus, there are six of them. The other rods, four in number, are of brass. The rod *i*, which supports the ball, is fixed at its upper end to a horizontal cross-piece; at its lower end it is free, and passes through the two circular holes in the lower horizontal cross-pieces.

Now from the manner in which the vertical rods are fixed to the cross-

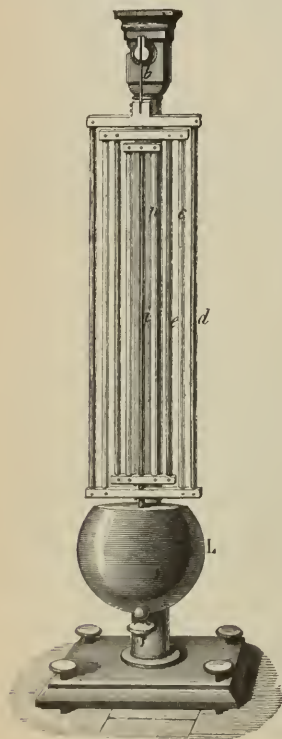

Fig. 315

pieces, it is easy to see that the elongation of the steel rods can only take place downward, and that of the brass rods upward. Consequently, in order that the pendulum may remain of the same length, it is necessary that the elongation of the brass rods shall tend to make the ball rise, by exactly the same quantity that the elongation of the steel rods tends to lower it; a result which is attained when the effective length A of the steel rods is to the effective length B of the brass rods in the inverse ratio of the coefficients of expansion of steel and brass, α and β ; that is, when $A : B = \beta : \alpha$.

The elongation of the rod may also be compensated for by means of *compensating strips*. These consist of two blades of copper and iron soldered together and fixed to the pendulum rod, as represented in fig. 316. The copper blade, which is more expansible, is below the iron. When the temperature sinks, the pendulum rod becomes shorter, and the ball rises. But at the same time the compensating strips become curved, as seen in fig. 317, in consequence of the copper contracting more than the iron, and two metal balls at their ends become lower. If they have the proper size in reference to the pendulum ball, the parts which tend to approach the centre of suspension compensate those which tend to remove from it, and the centre of oscillation is not displaced. If the temperature rises, the pendulum ball

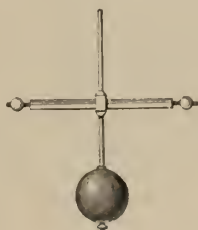

Fig. 316

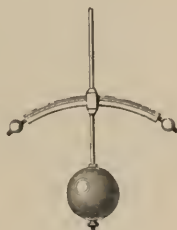

Fig. 317



Fig. 318

descends; but at the same time the small balls ascend, as shown in fig. 318, so that there is always compensation.

One of the simplest compensating pendulums is the *mercury pendulum*, invented by an English watchmaker, Graham. The ball of the pendulum, instead of being solid, consists of a glass cylinder, containing pure mercury, which is placed in a sort of stirrup, supported by a steel rod. When the temperature rises the rod and stirrup become longer, and thus lower the centre of gravity; but at the same time the mercury expands, and, rising in the cylinder, produces an inverse effect, and as mercury is much more expansible than steel, a compensation may be effected without making the mercurial vessel of undue dimensions.

The same principle is applied in the *compensating balances* of chronometers (fig. 319). The motion here is regulated by a *balance* or wheel, furnished with a spiral spring not represented in the figure, and the time of the chronometer depends on the elasticity of the spring, the mass of the balance, and its moment of inertia, *i.e.* on the distribution of its mass with regard to the axis of oscillation. Now when the temperature rises the diameter increases,

and the chronometer goes slower ; and, to prevent this, part of the mass must be brought nearer the axis. The circumference of the balance consists of compensating strips, BC, of two different metals, of which the more expansible is on the outside ; and towards the ends of these are small masses of metal, D, which play the same part as the balls in the above case. When the radius is expanded by heat, the small masses are brought nearer the centre in consequence of the curvature of the strips ; and as the small masses can be fixed in any position, they are easily arranged so as to compensate for the expansion of the balance. It may,

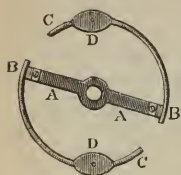

Fig. 319

however, here be observed that the chief action of heat on chronometers is to expand and soften the spring, and thereby lessen its elasticity ; this action produces five times the effect on the rate that the expansion of the balance-wheel does.

Successful experiments have been made with *invar* (317) for pendulums and the balance-wheels of chronometers. Possibly the use of this alloy will in the near future entirely supersede the compensating arrangements now in use.

CHAPTER III

EXPANSION OF LIQUIDS

322. **Apparent and real expansion.**—A hollow space enclosed by a solid expands as if it were wholly occupied by the solid ; for consider a section of a glass tube ; we may regard this as made up of a series of innumerable concentric circles ; when the tube is heated each of these glass circles becomes larger, and in doing so must press outwards, and these expansions are the same whether there is another circle within it or not ; the hollow space will become larger just as if it were a solid glass rod. This may be illustrated by the following experiment. If a flask of thin glass, provided with a narrow stem, the flask and part of the stem being filled with some coloured liquid, be immersed in hot water (fig. 320), the column of liquid in the stem at first sinks from *b* to *a*, but then immediately after rises, and continues to do so until the liquid inside has the same temperature as the hot water. The first sinking of the liquid is not due to its contraction ; it arises from the expansion of the glass, which becomes heated before the heat can reach the liquid ; but the expansion of the liquid soon exceeds that of the glass, and the liquid then rises.

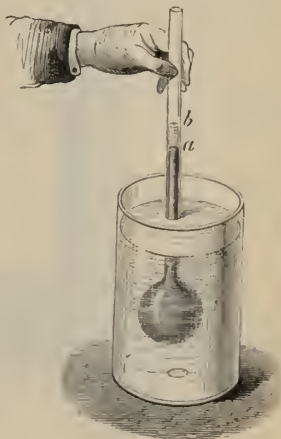

Fig. 320

Hence in the case of liquids we must distinguish between the *apparent* and the *real* or *absolute* expansion. The apparent expansion is that which is actually observed when liquids contained in vessels are heated ; the *absolute* expansion is that which would be observed if the vessel did not expand ; or, as this is never the case, it is the apparent expansion corrected for the simultaneous expansion of the containing vessel.

As has been already stated, in the case of liquids the cubical expansion is alone considered ; and, as in the case of solids, the *coefficient of expansion* of a liquid is the increase of the unit of volume for a rise of temperature one degree ; but a distinction is here made between the *coefficient of absolute expansion* and the *coefficient of apparent expansion*. Of the many methods which have been employed for determining these two coefficients, we shall describe that of Dulong and Petit.

323. **Coefficient of absolute expansion of mercury.**—In order to determine the coefficient of the absolute expansion of mercury, the influence of the envelope must be eliminated. Dulong and Petit's method depends on the hydrostatical principle that in two communicating vessels the heights of two columns of liquid in equilibrium are inversely as their densities (106), a principle independent of the diameters of the vessels, and therefore of their expansions.

The apparatus consists of two glass tubes, A and B (fig. 321), joined by a narrow tube and kept vertical on an iron support, KM, the horizontality of which is adjusted by means of two levelling screws and two spirit levels, *m* and *n*. Each of the tubes is surrounded by a metal case, of which the smaller, D, is filled with ice; the other, E, containing oil, can be heated by

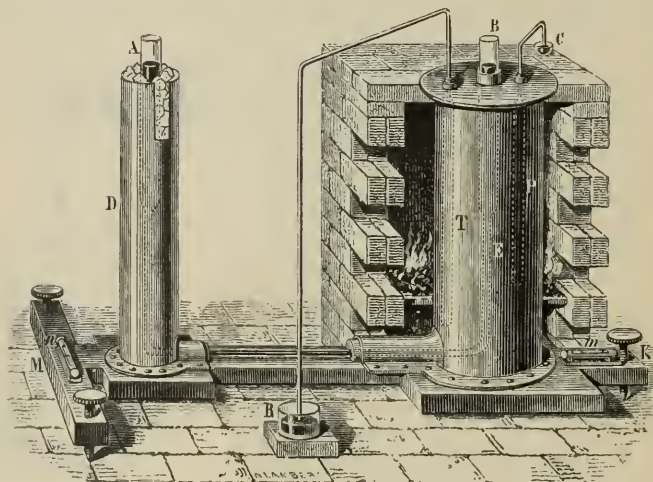

Fig. 321

the furnace, which is represented in section so as to show the case. Mercury is poured into the tubes A and B; it remains at the same level in both as long as they are at the same temperature, but rises in B in proportion as the temperature rises. The diameter of the horizontal tube is small enough to prevent any mixture of the hot and cold mercury, but freely allows hydrostatic pressure to be transmitted through it.

Let h and d be the height and density of the mercury in the leg A, at the temperature zero, and h' and d' the same quantities in the leg B, both heights being measured from the axis of the horizontal capillary tube. From the hydrostatic principle previously cited we have $hd = h'd'$. But from the problem in article 319, $d' = \frac{d}{1 + Dt}$, D being the coefficient of absolute expansion of mercury; substituting this value of d' in the equation, we have $\frac{h'd}{1 + Dt} = hd$, from which we get $D = \frac{h' - h}{ht}$.

The coefficient of absolute expansion of mercury is obtained from this formula, when we know the heights h' and h , and the temperature t of the bath in which the tube B is immersed. In Dulong and Petit's experiment this temperature was measured by a weight thermometer, P (325), the mercury of which overflowed into the basin, C, and by means of an air thermometer, T (336); the heights h' and h were measured by a cathetometer (87).

Dulong and Petit found by this method that the mean coefficient of absolute expansion of mercury between 0° and 100° C. is $\cdot 0001802$, but that it increases with the temperature. Between 100° and 200° it is $\cdot 0001844$, and between 200° and 300° it is $\cdot 0001887$. The same observation has been made in reference to other liquids, showing that their expansion is not regular. It has been found that this expansion is less regular in proportion as liquids are near a change in their state of aggregation; that is, approach their freezing or boiling points. Dulong and Petit found that the expansion of mercury between -36° and 100° is practically quite uniform.

Regnault repeated the experiments of Dulong and Petit with improved apparatus based on the same principle, and found that the mean coefficient between 0° and 100° is $\cdot 0001815$, between 100° and 200° , $\cdot 0001861$, and between 200° and 300° , $\cdot 0001917$.

324. **Coefficient of the apparent expansion of mercury.**—The coefficient of apparent expansion of a liquid varies with the nature of the envelope.

That of mercury in glass has been determined by means of the apparatus represented in fig. 322. It consists of a glass cylinder to which is joined a bent capillary glass tube, open at the end.



Fig. 322

The apparatus is weighed first empty, and then when filled with mercury at zero: the difference gives the weight of the mercury, P . It is then raised to a known temperature, t ; the mercury expands, and a certain quantity passes out, which is received in the capsule and weighed. If the weight of this mercury is ϕ , that of the mercury remaining in the apparatus will be $P - \phi$.

When the temperature is again zero, the mercury in cooling produces an empty space in the vessel, which represents the contraction of a volume of mercury whose weight is $P - \phi$, from t° to zero, or, what is the same thing, the expansion of the same weight from 0 to t° ; that is, the weight ϕ represents the expansion of the weight $P - \phi$, for t° . If this weight expands in glass by a quantity ϕ for t° , a single unit of weight would expand $\frac{\phi}{(P - \phi)}$ for t° , and

$\frac{\phi}{(P - \phi)t}$ for a single degree; consequently, since the weight of a substance at 0° is proportional to its volume, the coefficient of apparent expansion of mercury in glass, $D' = \frac{\phi}{(P - \phi)t}$. Dulong and Petit found the coefficient of apparent expansion of mercury in glass to be $\cdot 0001543$.

325. **Weight thermometer.**—The apparatus represented in fig. 322 is called the *weight thermometer*, because the temperature can be deduced from the weight of mercury which overflows.

The above experiments have placed the coefficient of apparent expansion at $\cdot 0001543$; we have therefore the equation $\frac{\phi}{(P-\phi)t} = \cdot 0001543$, a formula which gives the temperature t when the weights P and ϕ are known.

326. **Coefficient of the expansion of glass.**—As the absolute expansion of a liquid is the apparent expansion, *plus* the expansion due to the envelope, the coefficient of the cubical expansion of glass is obtained by taking the difference between the coefficient of absolute expansion of mercury and that of its apparent expansion in glass. That is, the coefficient of cubical expansion of glass is

$$\cdot 0001815 - \cdot 0001543 = \cdot 0000272.$$

Regnault found that the coefficient of expansion varies with different kinds of glass, and further with the shape of the vessel.

327. **Coefficients of expansion of various liquids.**—The coefficient of apparent expansion of liquids may be determined by means of an application of the principle of the weight thermometer, and the absolute expansion is obtained by adding to this coefficient the expansion of the glass.

Mean coefficients of absolute expansion of liquids for 1° C.

Ether	$\cdot 0\cdot 00015$	Alcohol	$\cdot 0\cdot 00104$
Mercury	$\cdot 0\cdot 00018$	Bromine	$\cdot 0\cdot 00104$
Water saturated with		Nitric acid	$\cdot 0\cdot 00110$
salt	$\cdot 0\cdot 00050$	Chloroform	$\cdot 0\cdot 00111$
Sulphuric acid	$\cdot 0\cdot 00063$	Bisulphide of carbon .	$\cdot 0\cdot 00114$
Fixed oils	$\cdot 0\cdot 00080$	Benzole	$\cdot 0\cdot 00125$
Oil of turpentine	$\cdot 0\cdot 00090$		

The numbers here given only hold for moderate temperatures. The coefficient of expansion of almost all liquids increases gradually from zero, and can only be expressed with accuracy by a somewhat complicated formula,

$$V_t = V_0(1 + at + \beta t^2 + \gamma t^3),$$

in which t is the temperature, and a , β , and γ are constants specially determined for each liquid. The expansion of mercury is practically constant between -36° and 100° C., while water contracts from zero to 4° (331), and then expands.

For many physical experiments a knowledge of the exact expansion of water is of great importance. This physical constant was carefully determined by Matthiessen, who found that between 4° and 30° it may be expressed by the formula

$$V_t = 1 - 0\cdot 00000253(t-4) + 0\cdot 0000008389(t-4)^2 + 0\cdot 0000007173(t-4)^3; \text{ and}$$

between 30° and 100° by $V_t = 0\cdot 999695 + 0\cdot 0000054724t^2 + 0\cdot 0000001126t^3$. Many liquids, with low boiling points, especially condensed gases, have very high coefficients of expansion. Thilorier found that liquid carbonic acid

expands four times as much as air. Drion confirmed this observation, and obtained analogous results with chloride of ethyl, liquid sulphurous acid, and liquid hyponitrous acid. Dewar has shown that liquid hydrogen expands ten times as much as air.

328. **Correction of the barometric height.**—If, while atmospheric pressure remains constant, the temperature rises, the barometer will rise, since a longer column of the less dense mercury will be required to balance the given pressure. To render the indications of this instrument comparable in different places and at different times, they must be reduced to a uniform temperature, which is that of melting ice. The correction is made in the following manner:—

Let H be the observed barometric height at t° , and h its height at zero, d the density of mercury at zero, and d' its density at t° . The heights H and h are inversely as the densities d and d' ; that is, $\frac{h}{H} = \frac{d'}{d}$. If we consider unit volume of mercury at zero, its volume at t° will be $1 + Dt$, D being the coefficient of absolute expansion of mercury. But these volumes, $1 + Dt$ and 1 , are inversely as the densities d' and d ; that is, $\frac{d'}{d} = \frac{1}{1 + Dt}$. Consequently

$\frac{h}{H} = \frac{1}{1 + Dt}$, whence $h = \frac{H}{1 + Dt}$. Replacing D by its value, '000181, we have

$$h = \frac{H}{1 + '000181t} = H(1 - '000181t).$$

In this calculation the coefficient of absolute expansion of mercury is taken, and not that of apparent expansion; for the value H is the same as if the glass did not expand, the barometric height being independent of the diameter of the tube, and therefore of its expansion.

If the barometric height is read off on a brass scale whose graduations are correct at 0° C., and which has a point attached to its lower end in contact with the mercury in the cistern, the reading at t° will be too low, and to obtain the correct reading at 0° the observed height must be multiplied by $1 + '0000187t$, since '0000187 is the coefficient of linear expansion of brass. Hence, finally

$$h = H(1 + '0000187t)(1 - '000181t) = H(1 - '000162t),$$

since the term in t^2 may be neglected.

329. **Correction of thermometric readings.**—If the whole column of mercury of a thermometer is not immersed in the space whose temperature is to be determined, it is necessary to make a correction, which in the accurate determination of boiling points, for instance, is of great importance, in order to arrive at the true temperature which the thermometer should show. That part of the stem which projects will have a temperature which must be estimated, and which may roughly be taken as something over that of the surrounding air.

Suppose, for instance, that the actual reading is 160° and that the whole of the part over 80° is outside the vessel, while the temperature of the surrounding air is 15° . We will assume that the mean temperature of the stem is 25° , and that a length of $160^\circ - 80^\circ$ is to be heated through $160 - 25 = 135^\circ$; this

gives $80 \times 135 \times .000154 = 1.66$ (taking the coefficient of apparent expansion of mercury); so that the true reading is 161.66 .

330. **Force exerted by liquids in expanding.**—The force which liquids exert in expanding is very great, and equal to that which would be required in order to bring the expanded liquid back to its original volume. Now we know what an enormous force is required to compress a liquid to even a very small extent (96). Thus between 0° and 10° , mercury expands by 0.0017790 of its volume at 0° ; its compressibility is 0.00000295 for one atmosphere; hence a pressure of more than 600 atmospheres would be requisite to prevent mercury expanding when it is heated from 0° to 10° . In like manner a pressure of 140 atmospheres would be required to prevent water from expanding when its temperature was raised from 4° to 14° .

331. **Expansion of water. Temperature of maximum density.**—Water presents the remarkable phenomenon that when its temperature sinks it contracts down to 4° ; but from that point, although the cooling continues, it expands to the freezing point, so that 4° represents the point of greatest contraction of water.

Many methods have been used to determine the temperature of the maximum density of water. Hope made the following experiment:—He took a deep vessel with two apertures in the sides, in which he fixed thermometers, and having filled the vessel with water at 0° , he placed it in a room at a temperature of 15° . As the layers of liquid at the sides of the vessel became heated they sank to the bottom, and the lower thermometer marked 4° while the upper one was still at zero. Hope then made the inverse experiment; having filled the vessel with water at 15° , he placed it in a room at zero. The lower thermometer having sunk to 4° remained stationary for some time, while the upper one cooled down until it reached zero. Both these experiments prove that water is heavier at 4° than at 0° , for in both cases the water at 4° sinks to the lower part of the vessel.

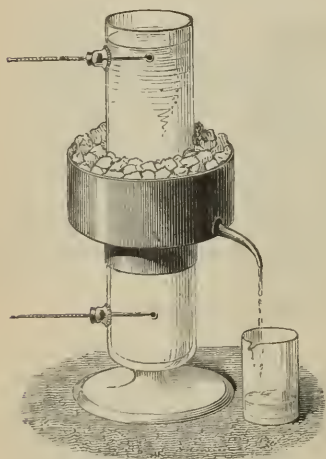

Fig. 323

This last experiment may be adapted for lecture illustration by using a cylinder containing water at 15° C., partially surrounded by a jacket containing bruised ice (fig. 323).

Hallström made a determination of the maximum density of water in the following manner:—He took a glass bulb, loaded with sand, and weighed it in water of different temperatures. Allowing for the expansion of glass, he found that 4.1° was the temperature at which it lost most weight, and consequently this was the temperature of the maximum density of water.

Despretz arrived at the temperature 4° by another method. He took a water thermometer—that is to say, a bulbed tube containing water—and,

placing it in a bath, the temperature of which was indicated by an ordinary mercury thermometer, found that, making due allowance for the change of volume of the glass bulb, the water contracted to the greatest extent at 4° , and that this therefore is the point of greatest density.

This phenomenon is of great importance in the economy of nature. In winter the temperature of lakes and rivers falls, from being in contact with the cold air and from other causes, such as radiation. The cold water sinks to the bottom, and a continual series of currents goes on until the whole has a temperature of 4° . The cooling on the surface still continues, but the cooled layers, being lighter than those below, remain on the surface, and ultimately freeze. The ice formed thus protects the water below, the lower portions of which remain at a temperature of 4° , even in the most severe winters, a temperature at which fish and other inhabitants of the water are not destroyed.

Salt dissolved in water lowers the temperature of the maximum density, and sea water exhibits a maximum. According to Rosetti, this temperature is between 3.2° and 3.9° in the Adriatic.

The following table of the density of pure water at various temperatures is based on several sets of observations :—

Density of water between 0° and 80° .

Tempe- ratures	Densities	Tempe- ratures	Densities	Tempe- ratures	Densities
0	0.99988	12	0.99955	24	0.99738
1	0.99993	13	0.99943	25	0.99714
2	0.99997	14	0.99930	26	0.99689
3	0.99999	15	0.99915	27	0.99662
4	1.00000	16	0.99900	28	0.99635
5	0.99999	17	0.99884	29	0.99607
6	0.99997	18	0.99870	30	0.99579
7	0.99994	19	0.99847	40	0.99226
8	0.99988	20	0.99827	50	0.98820
9	0.99982	21	0.99806	60	0.98232
10	0.99974	22	0.99785	70	0.97796
11	0.99965	23	0.99762	80	0.97191

Thus the mean expansion of water per degree between 0° and 80° is .000376, or a little more than twice that of mercury.

CHAPTER IV

EXPANSION AND DENSITY OF GASES

332. **Gay-Lussac's method.**—The volume of a gas may be altered by change of pressure as well as by change of temperature. The relation between pressure and volume when the temperature is constant—known as Boyle's law—has been already considered. In investigating the relation between volume and temperature, care must be taken to maintain the pressure constant.

The coefficient of expansion of a gas is the amount by which the unit of volume at 0° expands when its temperature is raised to 1° , the pressure being kept constant. Thus, if v_0 = the volume at 0° , v_t = volume at t° , and a = the mean coefficient of expansion between 0° and t° ,

$$v_t = v_0(1 + at).$$

It is immaterial what the pressure is so long as it does not vary.

This relation was discovered by Charles, and afterwards independently by Gay-Lussac and Dalton. It is generally referred to as the *law of Charles*.

The two laws—those of Boyle and Charles—are known as the *gaseous laws*.

Gay-Lussac determined the coefficient of the expansion of gases by means of the apparatus represented in fig. 324.

In a rectangular metal bath, about 16 inches long, was fitted an air thermometer, which consisted of a tube AB, about a millimetre in internal diameter, with a bulb, A, at one end. The tube was divided into parts of equal capacity, and the contents of the bulb ascertained in terms of these parts. This was effected by weighing the bulb and tube full of mercury at zero, and then heating

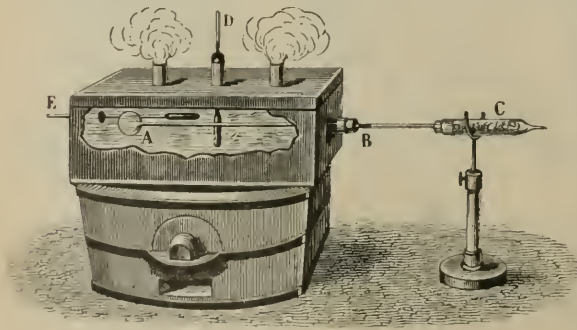

Fig. 324

slightly to expel a small quantity of mercury, which was weighed. The apparatus being again cooled down to zero, the vacant space in the tube

corresponded to the weight of mercury which had overflowed ; the volume of mercury remaining in the apparatus, and consequently the volume of the bulb, was determined by calculations analogous to those made for the piezometer (96).

In order to fill the thermometer with dry air it was first filled with mercury, which was boiled in the bulb itself. A tube, C, filled with calcium chloride, was then fixed on to its end by means of a cork. A fine platinum wire having then been introduced into the stem AB through the tube C, and the apparatus being slightly inclined and agitated from time to time, air entered, having been previously well dried by passing through the calcium chloride tube. The whole of the mercury was displaced, with the exception of a small thread, which remained in the tube AB as an index.

The air thermometer was then placed in the box filled with melting ice, the index moved towards A, and the point was noted at which it became stationary. This gave the volume of air at zero, since the capacity of the bulb was known. Water or oil was then substituted for the ice, and the bath successively heated to different temperatures. The air expanded and moved the index from A towards B. The position of the index in each case was noted, and the corresponding temperature was indicated by means of the thermometers D and E.

The pressure of the atmosphere was practically constant during the experiment, and, the expansion of the glass being neglected, the expansion of the air was obtained by subtracting from its volume at a given temperature its volume at 0°. From this the coefficient of expansion is deduced.

The results obtained by Gay-Lussac in these experiments were not very exact. The more recently determined coefficients of expansion of different gases are given on p. 323.

333. **Combination of formulæ of Boyle and Charles.**—Let p_1, v_1 be the pressure and volume of a given quantity of gas at temperature t_1 ; p_2, v_2 the pressure and volume at t_2 . Also, let w be the volume when the temperature is t_1 and the pressure p_2 . Then, by Boyle's law, $p_1 v_1 = p_2 w$, since the temperature t_1 is constant ; and by Charles's law, $\frac{v_2}{1 + at_2} = \frac{w}{1 + at_1}$, since the pressure p_2 is constant. Hence, eliminating w , $\frac{p_1 v_1}{1 + at_1} = \frac{p_2 v_2}{1 + at_2}$; or, generally, for a given weight of gas $\frac{pv}{1 + at}$ is constant, whatever changes take place in p, v , or t .

Examples.—i. The volume of a gas at t° , and under the pressure H, is V' : what will be the volume V of the same gas at zero, and under the normal pressure 760 millimetres ?

From the above formula it follows at once that $V = \frac{V'H}{(1 + at) 760}$.

ii. A quantity of gas weighs P' at t° : what will be the weight of an equal volume at zero, the pressure being constant ?

Let P be the desired weight, a the coefficient of expansion of the gas, d its density at t° , and d its density at zero. As the weights of equal

volumes are proportional to the densities, we have $\frac{P'}{P} = \frac{d'}{d}$. If v be the volume of a gas at zero, its volume at t will be $v(1 + \alpha t)$; but as the densities are inversely as the volumes, $\frac{d'}{d} = \frac{1}{1 + \alpha t}$, and therefore $\frac{P'}{P} = \frac{1}{1 + \alpha t}$; whence $P = P'(1 + \alpha t)$.

334. **Regnault's methods.**—Regnault used several different methods for determining the expansion of gases. In some of them the pressure was constant and the volume variable, as in Gay-Lussac's method; in others the volume remained the same while the pressure varied. The method described below is the same as that used by Rudberg and Dulong, but is distinguished by the care with which all sources of error are avoided. In this method both the pressure and the volume of the gas varied.

The apparatus consisted of a cylindrical reservoir, B (fig. 325), terminating in a bent capillary tube.

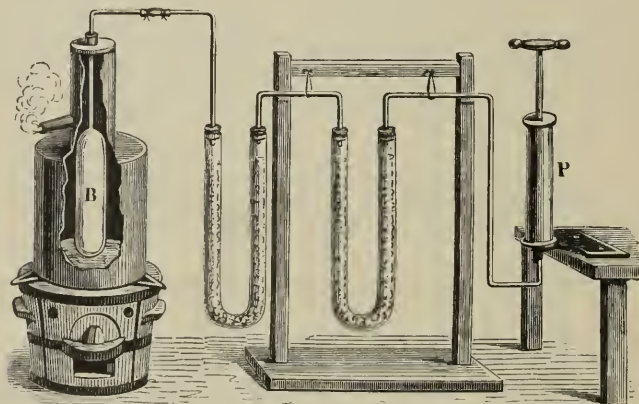

Fig. 325

air, it was placed in a hot-water bath, and the capillary tube connected by an india-rubber tube with a series of drying tubes. These tubes were joined to a small air-pump, P, by which a fairly good vacuum could be produced in the reservoir while at a temperature of 100° . The reservoir was first exhausted, and air afterwards admitted slowly; this operation was repeated a great many times, so that the air in the reservoir became quite dry, for the moisture adhering to the sides passed off in vapour at 100° , and the air which entered became dry in its passage through the U tubes.

The reservoir was then kept for half an hour at the temperature of boiling water; the air-pump having been detached, the drying tubes were then disconnected, and the end of the tube hermetically sealed, the height H of the barometer being noted. When the reservoir B was cool, it was placed in the apparatus represented in fig. 326. It was there quite surrounded with ice, and the end of the tube dipped in the mercury bath, C. After the

air in the reservoir B had sunk to zero, the point *b* was broken off by means of a pair of forceps; the air in the interior became condensed by atmospheric pressure, the mercury rising to a height *oG*. In order to measure the height of this column, *G_o*, which will be called *h*, a movable rod, *g_o*, was lowered until its point, *o*, was flush with the surface of the mercury in the bath; the distance between the point *o* and the level of the mercury *G* was measured by means of the cathetometer. The point *b* was finally closed with wax by means of the spoon *a*, and the barometric pressure noted at this moment. If this pressure is *H'*, the pressure of the air in B is *H' - h*.

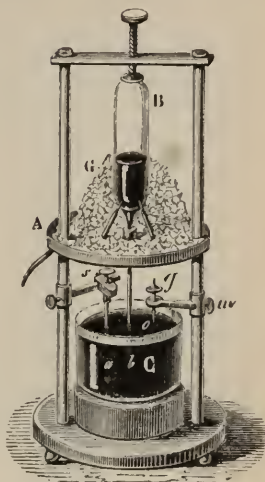

Fig. 326

The reservoir was now weighed to ascertain *P*, the weight of the mercury which it contained. It was then completely filled with mercury at zero, in order to have the weight *P'* of the mercury in the reservoir and in the tube.

If δ is the coefficient of cubical expansion of glass, and *D* the density of mercury at zero, the coefficient *a* of cubical expansion of air is determined in the following manner:—The volume of the reservoir and of the tube at zero is $\frac{P'}{D}$, from the formula $P = VD$; consequently this volume is

$$\frac{P'}{D} (1 + \delta t) \dots \dots \dots (1)$$

at the temperature t° , assuming, as is the case, that the reservoir and tube expand as if they were solid glass (322). But from the formula $P = VD$, the volume of air in the reservoir at zero, and under the pressure $H' - h$, is $\frac{P' - P}{D}$. At the same pressure, but at t° , its volume would be

$$\frac{P' - P}{D} (1 + at);$$

and by Boyle's law (181), at the pressure *H*, at which the tube was sealed, this volume must have been

$$\frac{(P' - P) (1 + at) (H' - h)}{DH} \dots \dots \dots (2)$$

Now the volumes represented by these formulæ (1) and (2) are each equal to the volume of the reservoir and the tube at t° : they are therefore equal. Removing the denominators, we have

$$P' (1 + \delta t) H = (P' - P) (1 + at) (H' - h) \dots \dots \dots (3)$$

from which the value of *a* is deduced.

335. **Regnault's methods** (*continued*).—In the method described above both the volume and pressure of the gas were altered when the temperature changed. By other methods, which will now be described, Regnault determined (1) the relation between temperature and volume when the pressure was kept constant, and (2) the relation between temperature and pressure when the volume was kept constant.

Constant pressure.—In fig. 327 C is the bulb containing the gas ; it is connected with the manometer AB by a fine tube, F. G is a reservoir of mercury

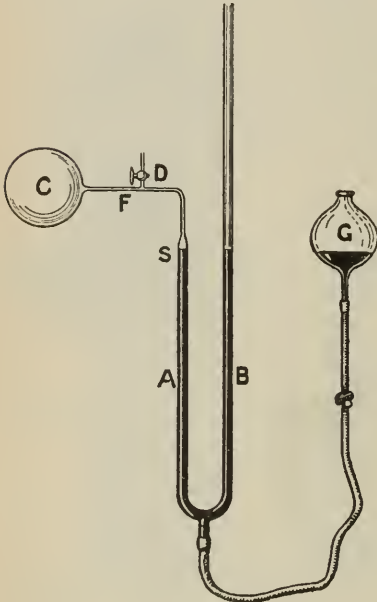

Fig. 327

connected to the lower part of the manometer by flexible tubing ; as it is raised or lowered the height of the mercury in the limbs of the manometer is altered. A lateral tube, D, provided with stopcock and attached to F, allows the bulb to be put in communication with an exhausting pump, and with the gas whose coefficient of expansion is required. The bulb C is placed in an enclosure whose temperature can be maintained at any point from 0° to 100° . First let the enclosure be filled with melting ice, and, the vessel C and tube F now containing dry gas, the surfaces of the mercury in A, B, G are adjusted to the same level. The temperature is then raised to t° , the gas expands, and the mercury tends to fall in A and rise in B and G ; but the surfaces are brought to the same level by lowering G, so as to maintain the pressure constant and equal to that of the atmosphere. The tubes F and

A have been previously calibrated, so that their capacities per millimetre of length are known in terms of the capacity of the bulb C. Thus the increase of volume is measured corresponding to a given rise of temperature at constant pressure, and the coefficient of expansion is obtained from the equation $v_t = v_0(1 + \alpha t)$.

Constant volume.—The same figure may be used to illustrate Regnault's method of determining the coefficient of increase of pressure of a gas due to change of temperature when the volume is kept constant. This coefficient is sometimes called the *coefficient of expansion at constant volume*. A mark is made on the tube A at S, and the mercury adjusted to S when the pressure is atmospheric and the temperature 0° . When the temperature in the bulb C rises the gas expands, but depression of the mercury in A is prevented by raising the reservoir G, and thus increasing the pressure to which the gas in the bulb is subjected. G is raised until the mercury in A is brought back to the mark S, and the pressure of the gas is then that due to the difference in heights in the tubes A and B, together with that of the

atmosphere. The process is repeated with gradually rising temperatures, and a series of corresponding values of p and t obtained. The coefficient required is derived from the equation

$$p_t = p(1 + a't).$$

The following table gives both coefficients for different gases:—

Coefficients of expansion of gases (Regnault)

	Pressure Constant a	Volume Constant a'
Hydrogen	·003661	·003667
Atmospheric air	·003670	·003665
Nitrogen	—	·003668
Carbon monoxide	·003669	·003667
„ dioxide	·003710	·003688
Nitrogen monoxide	·003719	·003676
Sulphur dioxide	·003993	·003845
Cyanogen	·003877	·003829

It appears from the above table that hydrogen differs from the other gases enumerated in that a' is greater than a for it, while for all the rest a is the greater. We have already seen that at ordinary temperatures, and for moderate pressure, hydrogen differs from other gases in being less compressible than Boyle's law requires.

Regnault has further found that, at the same temperature, the coefficient of expansion of any gas increases with the pressure which it supports. Thus, while the coefficient of expansion of air under a pressure of 110 mm. is 0·003648, under a pressure of 3655 mm., or nearly five atmospheres, it is 0·003709.

The number found by Regnault for the coefficient of the expansion of air, 0·003665, is equal to $\frac{1}{272\cdot9} = \frac{1}{273}$ nearly; and if we take the coefficient of expansion at 0·003666 . . . it may be represented by the fraction $\frac{1}{273}$, which is convenient for many purposes of calculation.

The small differences in the expansibility of various gases may be ascribed to the circumstance that when a gas is heated the relative positions of the atoms in the molecules are thereby altered; and a certain amount of internal work is required for this, which is different for different gases (294).

The researches of Amagat prove that at constant pressure the coefficients of expansion diminish as the temperature rises. For example, for sulphurous acid the coefficient between 10° and 60° C. is 0·003903, but between 10° and 250° becomes 0·003798. The change with temperature is much less in the case of gases that are not readily liquefiable.

336. **Air thermometer.**—When the laws of the expansion of air are known the apparatus of fig. 327 may be used as an air thermometer, either for determining directly the temperature of an enclosure or for standardising mercury thermometers and various kinds of pyrometers. Regnault found that the air and the mercury thermometer agree up to 260°, but above

that point mercury expands relatively more than air. In cases where very high temperatures are to be measured, the reservoir is made of platinum. The use of an air thermometer is seen in Dulong and Petit's experiment (323); it was by such an apparatus that Pouillet measured the temperature corresponding to the colours which metals take when heated in a fire, and found them to be as follows:—

Incipient red	525° C.	Dark orange	1100° C.
Dull red	700	White	1300
Cherry red	900	Dazzling white	1500

In the measurement of high temperatures Deville and Troost used with advantage the vapour of iodine instead of air, and, as platinum has been found to be permeable to gases at high temperatures, they employed porcelain instead of that metal.

337. **Absolute zero.**—If we substitute $\frac{2}{273}$ for a in the formula $\frac{pv}{1+at} =$ constant, we may write $\frac{pv}{273+t} =$ constant. Hence, if temperatures are measured from a point 273 degrees Centigrade below the freezing point of water, we may call this latter temperature the absolute zero, and temperatures measured from it absolute temperatures. Thus, the absolute temperature of the freezing point of water will be 273° C., and that of the boiling point of water 373° C. If temperatures measured from the absolute zero are denoted by T , the formula above becomes $pv/T =$ constant, or $pv = kT$, where k is a constant depending on the nature and quantity of the gas.

A gas for which the formula $pv = kT$ would hold is an ideal perfect gas. The formula involves the assumption that the particles of the gas are mere points having no extension in space, and also that there are no intermolecular forces. For the more permanent gases, nevertheless, the law expressed by the formula is very nearly true (182).

338. **Density of gases.**—The relative *density* of a gas, or its *specific gravity*, is the ratio of the weight of a certain volume of the gas to that of the same volume of air; both the gas and the air being at zero and under a pressure of 760 millimetres.

In order, therefore, to find the specific gravity of a gas, it is necessary to determine the weight of a certain volume of this gas at a pressure of 760 millimetres, and a temperature of zero, and then the weight of the same volume of air under the same conditions. For this purpose a large globe of about two gallons capacity is used, the neck of which is provided with a stopcock, which can be screwed to the air-pump. The globe is first weighed empty, and then full of air, and afterwards full of the gas in question. The weights of the gas and of the air are obtained by subtracting the weight of the exhausted globe from the weight of the globe filled, respectively, with air and gas. The quotient, obtained by dividing the latter by the former, gives the specific gravity of the gas. It is difficult to make these determinations at the same temperature and pressure, and therefore all the weights are reduced to zero and the normal pressure of 760 millimetres.

The gases are dried by causing them to pass through drying tubes before they enter the globe, and air must also be passed over potash to free it from

carbonic acid. And as even the best air-pumps never produce a perfect vacuum, it is necessary to exhaust the globe until the manometer in each case marks the same pressure.

The globe having been exhausted, dried air is allowed to enter, and the process is repeated several times until the globe is perfectly dried. It is then finally exhausted until the residual pressure in millimetres is e . The weight of the exhausted globe is ϕ . Air, which has been dried and purified by passing through potash and calcium chloride tubes, is then allowed to enter slowly. The weight of the globe full of air is P . If H is the barometric height in millimetres, and t° the temperature at the time of weighing, $P - \phi$ is the weight of the air in the globe at the temperature t , and the pressure $H - e$.

To reduce this weight to the pressure 760 millimetres and the temperature zero, let a be the coefficient of the expansion of air, and δ the coefficient of the cubical expansion of glass. From Boyle's law the weight, which is $P - \phi$ at t° and a pressure of $H - e$, would be $\frac{(P - \phi) 760}{H - e}$ under the pressure 760 millimetres and at the same temperature, t° . If the temperature is 0° , the capacity of the globe will diminish in the ratio $1 + \delta t$ to 1, while the weight of the gas increases in the ratio $1 : 1 + at$, as follows from the problems in article 333. Consequently, the weight of the air in the globe at 0° and at the pressure 760 millimetres will be

$$(P - \phi) \frac{760 (1 + at)}{(H - e) (1 + \delta t)} \dots \dots \dots (1)$$

Further, let a' be the coefficient of expansion of the gas in question; let P' be the weight of the globe full of gas at the temperature t' and the pressure H' , and let ϕ' be the weight of the globe when it is exhausted to the pressure e ; the weight of the gas in the globe at the pressure 760 and the temperature zero will be

$$(P' - \phi') \frac{760 (1 + a't')}{(H' - e) (1 + \delta t')} \dots \dots \dots (2)$$

Dividing the latter formula by the former we obtain the density

$$D = \frac{(P' - \phi') (H - e) (1 + a't') (1 + \delta t)}{(P - \phi) (H' - e) (1 + at) (1 + \delta t')}$$

If the temperature and the pressure do not vary during the experiment,

$$H = H' \text{ and } t = t'; \text{ whence } D = \frac{(P' - \phi') (1 + a't')}{(P - \phi) (1 + at)}, \text{ and, if } a = a', D = \frac{P' - \phi'}{P - \phi}.$$

339. **Regnault's method of determining the density of gases.**—Regnault so modified the above method that many of the corrections may be dispensed with. The globe in which the gas is weighed is suspended from one pan of a balance, and is counterpoised by means of a second globe of the same dimensions, and hermetically sealed, suspended from the other. These two globes, expanding at the same time, always displace the same quantity of air, and consequently variations in the temperature and pressure of the atmosphere do not influence the weighing. The globe, too, is filled with air or with the gas, at the temperature of zero. This is effected by placing it in a

vessel full of ice, as shown in fig. 328. It is then connected with a three-way cock, A, by which it may be put into communication either with an air-pump, or with the tubes M and N, which are connected with the reservoir of gas. The tubes M and N contain substances which by their action on the gas dry and also purify it.

The stopcock A being so turned that the globe is only connected with the air-pump, a vacuum is produced; by means of the same cock, the connection with the pump being cut off, but established with M and N, the gas soon fills the globe. But as the exhaustion could not have been complete, and some air must have been left, the globe is again exhausted and the gas allowed to enter, and the process is repeated until it is thought that

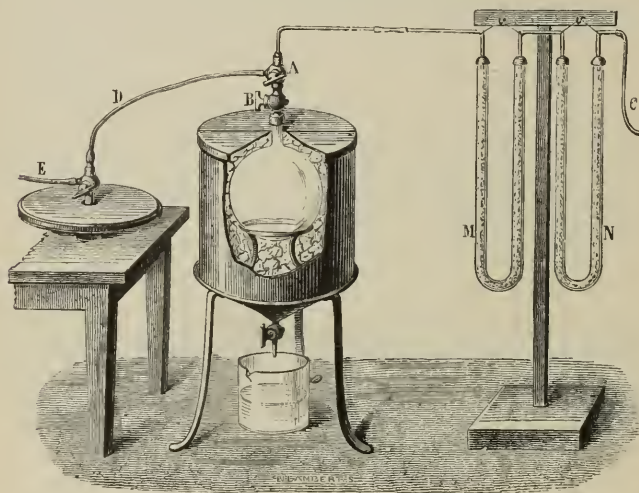

Fig. 328

all air is removed. The vacuum being once more produced, a differential barometer (fig. 158), connected with the apparatus by the tube E, indicates the pressure e of the residual rarefied gas. When the cock B is closed and detached, the globe is removed from the ice, and after being cleaned is weighed.

This gives the weight ϕ of the empty globe; the globe is again replaced in the ice, the stopcock A adjusted, and the gas allowed to enter, care being taken to leave the stopcocks open long enough to allow the gas in the globe to acquire the pressure of the atmosphere, H, which is marked by the barometer. The stopcock A is then closed, A removed, and the globe weighed with the same precautions as before. This gives the weight P' of the gas and globe.

The same operations are then repeated on this globe with air, and two corresponding weights ϕ and P are obtained. The only correction necessary is to reduce the weights in the two cases to the standard pressure by the

method described in the preceding paragraph. The correction for temperature is not needed, as the gas is at the temperature of melting ice. The ratio of the weight of the gas to that of the air is thus obtained by the formula

$$D = \frac{P' - p'}{P - p}$$

340. **Density of gases which attack metals.**—For gases which attack the ordinary metals, such as chlorine, a metal stopcock cannot be used, and vessels with ground-glass stoppers (fig. 329) are substituted. The gas is introduced by a bent glass tube, the vessel being held either upright or inverted, according as the gas is heavier or lighter than air; when the vessel is supposed to be full, the tube is withdrawn, the stopper inserted, and the weight taken. This gives the weight of the vessel and gas. If the capacity of the vessel is measured by means of water, the weight of the air which it contains is deduced, for the density of air at 0° C. and 760 millimetres pressure is $\frac{1}{770}$ that of distilled water under the same circumstances. The weight of the vessel full of air, less the weight of the contained air, gives the weight of the vessel itself. From these three data—the weight of the vessel full of the gas, the weight of the air which it contains, and the weight of the vessel alone—the specific gravity of the gas is readily deduced, the necessary corrections being made for temperature and pressure.



Fig. 329

Relative density of gases at zero and at a pressure of 760 millimetres, that of air being taken as unity

Air	1.0000	Sulphuretted hydrogen	1.1912
Hydrogen	0.0693	Hydrochloric acid	1.2540
Ammonia	0.5367	Nitrous oxide (N_2O)	1.5270
Marsh gas	0.5590	Carbonic acid	1.5291
Carbonic oxide	0.9670	Cyanogen	1.8600
Nitrogen	0.9714	Sulphurous acid	2.2474
Nitric oxide (NO)	1.0360	Chlorine	3.4400
Oxygen	1.1057	Hydriodic acid	4.4430

Regnault made the following determinations of the weight of a litre of the most important gases at 0° C. and 760 mm. :—

Air	1.293187 grms.	Nitrogen	1.256157 grms.
Oxygen	1.429802 ,,	Carbonic acid	1.977414 ,,
Hydrogen	0.089578 ,,		

CHAPTER V

CHANGES OF CONDITION. VAPOUR

341. **Fusion. Its laws.**—The only phenomena of heat with which we have hitherto been engaged have been those of expansion. In the case of solids it is easy to see that this expansion is limited. For in proportion as a body absorbs heat, the kinetic energy of the molecules is increased, and ultimately a point is reached at which the molecular attraction is not sufficient to retain the body in the solid state. A new phenomenon is then produced; *melting* or *fusion* takes place; that is, the body passes from the solid into the liquid state.

Some substances, however, such as paper, wood, wool, and certain salts, do not fuse at a high temperature, but are decomposed. Many bodies have long been considered *refractory*—that is, incapable of fusion; but, in proportion as it has been possible to produce higher temperatures, their number has diminished. Gaudin succeeded in fusing rock crystal by means of a lamp fed by a jet of oxygen; and Despretz, by combining the effects of the sun, the voltaic battery, and the oxy-hydrogen blowpipe, melted alumina and magnesia, and softened carbon so as to be flexible, which is a condition near that of fusion.

It has been found experimentally that the fusion of bodies is governed by the two following laws:—

I. *Every substance begins to fuse at a certain temperature, which is invariable for each substance, if the pressure be constant.*

II. *Whatever be the intensity of the source of heat, from the moment fusion begins the temperature of the body ceases to rise, and remains constant until the fusion is complete.*

Melting points of certain substances

Ethylene	− 169°	Butter	+ 33°
Alcohol	− 130·5	Rubidium	39
Ether	− 129	Phosphorus	44
Ammonia	− 75	Spermaceti	49
Mercury	− 38·8	Potassium	55
Oil of turpentine	− 27	Margaric acid	57
Bromine	− 12	Stearine	60
Ice	0	White wax	65
Nitrobenzene	+ 3·0	Wood's fusible metal	68
Formic acid	8·5	Stearic acid	70
Acetic acid	17	Sodium	90

Rose's fusible metal	+ 94°	Aluminium	+ 655°
Sulphur	114	Magnesium	750
Benzoic acid	120	Sodium chloride	851
Indium	176	Silver	955
Tin	232	Gold	1060
Bismuth	269	Copper	1068
Cadmium	321	Potassium sulphate	1073
Lead	328	Cast iron	1100
Zinc	419	Mild steel	1300
Arsenic	500	Wrought iron	1600
Potassium iodide	623	Platinum	1730
Antimony	630	Iridium	1950

Some substances pass from the solid to the liquid state without showing any definite melting point ; for example, glass and iron become gradually softer and softer when heated, and pass by imperceptible stages from the solid to the liquid condition. This intermediate condition is spoken of as the state of *vitreous fusion*. Such substances may be said to melt at the lowest temperature at which perceptible softening occurs, and to be fully melted when the further elevation of temperature does not make them more fluid ; but no precise temperature can be given as that of their melting points.

The determination of the melting point of a body is a matter of considerable importance in fixing the identity of many chemical compounds, and is, moreover, of frequent practical application in determining the commercial value of tallow and other fats.

It is done as follows :—A portion of the substance is melted in a watch-glass, and a small quantity of it sucked into a fine capillary tube, which is then placed in a bath of clear water (fig. 330) attached to a thermometer, and the temperature of the bath is gradually raised until the substance is completely melted, which from its small mass is very easily observed. The bath is then allowed to cool, and the solidifying point noted ; and the mean of the two is taken as the true melting point.

342. **Influence of pressure on the melting point.**—It follows from the principles of the mechanical theory of heat that, with an increase of pressure, the melting point of a body must be raised or lowered according as the substance expands or contracts in passing from the solid into the liquid state. Bunsen examined the influence of pressure on the melting point by means of the apparatus represented in fig. 331, somewhat resembling in appearance a siphon barometer. The tube is closed at both ends. The

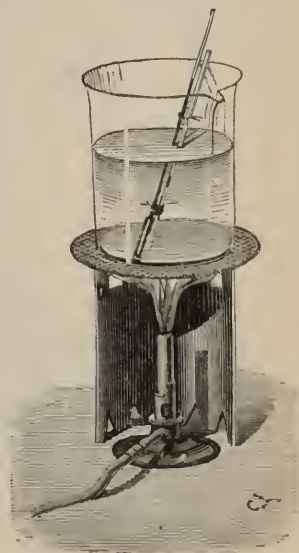

Fig. 330

part from *b* to *c* contains mercury except at the end *b*, where the substance under examination is put. Air occupies the portion *ac*, which is carefully calibrated. The lower part of the apparatus is placed in a water bath, the mercury being heated as well as the substance. The expansion of the mercury compresses the air, the elastic force of which reacts on the substance and exerts on it a gradually increasing pressure. It only then remains to observe the temperature at which the substance solidifies, and the corresponding pressure at that moment. In this way Bunsen found that spermaceti, which melts at 48° under a pressure of 1 atmosphere, melts at 51° under a pressure of 156 atmospheres. Hopkins found that spermaceti

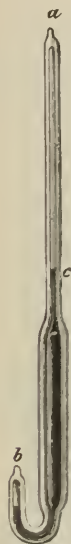

Fig. 331

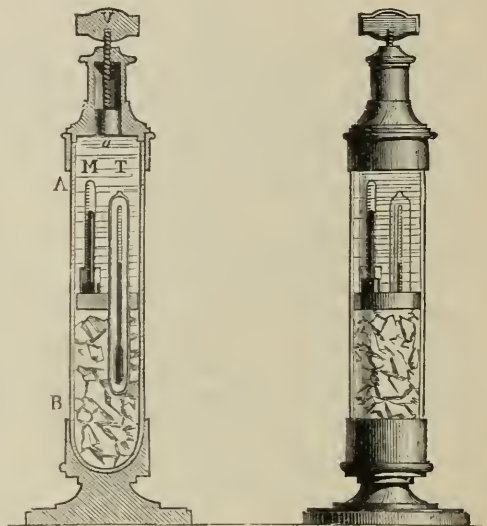

Fig. 332

melted at 60° under a pressure of 519 atmospheres and at 80° under 792 atmospheres; the melting point of sulphur under these pressures was respectively 135° and 141° .

Ice is a substance which contracts on melting; hence, according to the theory, the effect of increased pressure should be to cause ice to melt at a lower temperature than 0° C. For the purpose of determining experimentally the relation between the pressure and the temperature of fusion of ice, Lord Kelvin made use of the apparatus shown in fig. 332. It consisted of a piezometer which, by means of a thick leaden ring, was divided into two compartments, the upper one containing water and the lower one crushed ice, which was thus prevented from rising. The leaden ring also served to support a thermometer enclosed in a very stout tube, and a manometer with compressed air. The pressures were exerted by means of a screw piston V.

The thermometer T indicated the temperature at which ice and water remain in presence of each other without change, *i.e.* the melting point of

ice. This temperature is 0° C. when the pressure is atmospheric ; when the pressure was increased by means of the screw V, the temperature fell. The change was small but definite ; Lord Kelvin found that pressures of 8.1 and 16.8 atmospheres lowered the melting point of ice by 0.059° and 0.126° respectively. These results justify the theoretical previsions of his brother, Professor J. Thomson, according to which an increase of pressure of n atmospheres lowers the melting point of ice by $0.0074n^{\circ}$ C., so that a pressure of 135 atmospheres, or about 2000 pounds to the square inch, would lower the melting point 1° C.

This lowering of the melting point is also shown by an experiment of Mousson. The apparatus consists of a stout steel tube closed at one end by a screw and with a screw piston at the other (fig. 333). The tube is filled with water and a metal bullet introduced. When the apparatus is closed it is inverted so that the bullet rests on the piston, and is placed thus in a freezing mixture ; the water freezes and presses the ball against the piston. The apparatus is again inverted, and pressure is gradually applied by turning the handle of the screw. When the lower screw is opened the ball falls out, and is followed by a thick cylinder of ice which must have been formed at the moment of opening. Hence the ice must, by a pressure estimated at 13,000 atmospheres, have been converted into water at about -18° C.

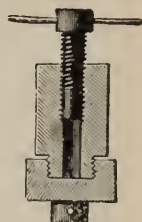

Fig. 333

This influence is likewise readily demonstrated by an experiment of von Helmholtz (fig. 334). Water is boiled in a flask until all air is expelled, and it is then closed. It is afterwards placed in a freezing mixture so that some ice forms inside. This is then allowed to melt again in great part, and the flask is placed in a vessel of water containing lumps of ice. It is then found that the still unfrozen water inside the flask freezes while that of the outside is melting.

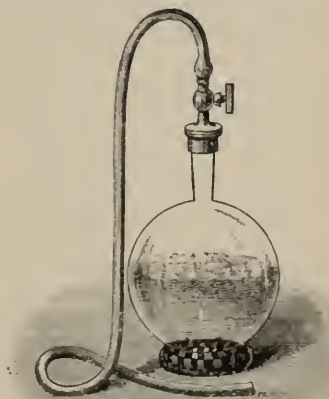

Fig. 334

It is then found that the still unfrozen water inside the flask freezes while that of the outside is melting.

343. Alloys. Fluxes.—Alloys are generally more fusible than any of the metals of which they are composed ; for instance, an alloy of 5 parts of tin and 1 of lead fuses at 194° . The alloy known as *Rose's fusible metal*, which consists of 4 parts of bismuth, 1 part of lead, and 1 of tin, melts at 94° , and an alloy of 1 or 2 parts of cadmium with 2 parts of tin, 4 parts of lead, and 7 or 8 parts of bismuth, known as *Wood's fusible metal*, melts between 66° and 71° C. An alloy of potassium and sodium in equivalent proportions is liquid at the ordinary temperature. Fusible alloys are of extended use in soldering and in taking casts. Steel melts at a lower temperature than iron, though it contains carbon, which is almost completely infusible.

Mixtures of the fatty acids melt at lower temperatures than the pure acids. A mixture of potassium and sodium chlorides fuses at a lower temperature than either of its constituents; this is also the case with a mixture of potassium and sodium carbonates, especially when they are mixed in the proportion of their chemical equivalents.

An application of this property is met with in the case of *fluxes*, which are much used in metallurgical operations. They consist of substances which, when added to an ore, partly by their chemical action, help the reduction of the substance to the metallic state, and, partly, by presenting a readily fusible medium, promote the agglomeration of the individual particles with the formation of a mass of metal or *regulus*.

344. **Latent heat.**—Since, during the passage of a body from the solid to the liquid state, the temperature remains constant until the fusion is complete, whatever the intensity of the source of heat, it must be concluded that, in changing their condition, bodies absorb a considerable amount of heat, the only effect of which is to maintain them in the liquid state. This heat, which is not indicated by the thermometer, is called *latent heat* or *latent heat of fusion*, an expression which, though not in strict accordance with modern ideas, is convenient from the fact of its universal recognition and employment (467).

An idea of what is meant by latent heat may be obtained from the following experiment:—If a pound of water at 80° is mixed with a pound of water at zero, the temperature of the mixture is 40° . But if a pound of crushed ice at zero is mixed with a pound of water at 80° , the ice melts and two pounds of water at zero are obtained. Consequently the mere change of a pound of ice to a pound of water at the same temperature requires as much heat as will raise a pound of water through 80° . This quantity of heat represents the latent heat of the fusion of ice, or the latent heat of water.

Every liquid has its own latent heat, and in the chapter on Calorimetry we shall show how this is determined.

345. **Solution.**—A body is said to *dissolve* when it becomes liquid in consequence of an attraction between its molecules and those of a liquid. Gum arabic, sugar, and most salts dissolve in water. The weight dissolved in a given quantity of water generally increases with the temperature, as is seen from the following table:—

	Common Salt	Nitre	Sodium Sulphate	Copper Sulphate	Zinc Sulphate
0°	35	13	6	32	115
20	37	21	53	42	131
100	40	247	42	203	654

The peculiarity in the solubility of sodium sulphate is due to the fact that the hydrated salt ($\text{Na}_2\text{SO}_4 \cdot 10\text{H}_2\text{O}$) loses its water of crystallisation and becomes anhydrous at about 33°C .

When a liquid has dissolved as much as it can at a particular temperature, it is said to be *saturated*.

The belief formerly held that the properties of a liquid were altered, when a body was dissolved in it, nearly in proportion to the quantity dissolved is

not confirmed by the results of electrolysis. The first small quantity dissolved produces a far greater change than a subsequent equal quantity.

When a salt dissolves in water it may be supposed that the vibrations of its bounding molecules, which are in contact with the solvent, possibly owing to the attraction of the solvent, or owing to capillarity, increase their amplitude, so that they get beyond the sphere of action of the other molecules of the salt, and thereby assume a progressive motion like the molecules of a gas. Like them they then exert a pressure against the sides of the containing vessel, which is called *osmotic pressure* (139).

During solution, as well as during fusion, a certain quantity of heat always becomes latent, and hence it is that the solution of a substance usually produces a diminution of temperature. In certain cases, however, instead of the temperature being lowered, it actually rises, as when caustic potash is dissolved in water. This depends upon the fact that two simultaneous and contrary phenomena are produced. The first is the passage from the solid to the liquid condition, which always lowers the temperature. The second is the *chemical* combination of the body dissolved with the liquid, which, as in the case of all chemical combinations, produces an increase of temperature. Consequently, as the one or the other of these effects predominates, or as they are equal, the temperature either rises or sinks, or remains constant.

346. **Solidification.**—*Solidification* or *congelation* is the passage of a body from the liquid to the solid state. This phenomenon is expressed by the two following laws :—

I. *Every body, under the same pressure, solidifies at a fixed temperature, which is the same as that of fusion.*

II. *From the commencement to the end of the solidification, the temperature of a liquid remains constant.*

Certain bodies, more especially some of the fats, present an exception to the first law, in so far that by repeated fusions they seem to undergo a molecular change which alters their melting point.

The second law is the consequence of the fact that the latent heat absorbed during fusion becomes free at the moment of solidification.

The application of the very low temperatures which can now be so readily procured has lessened the number of those liquids which it was formerly thought could not be solidified. By allowing liquid ethylene to boil in a vacuum, Wroblewski and Olszewski obtained a temperature of -136° . They observed that carbon disulphide solidified at -116° and fused again at about -110° . Absolute alcohol became viscid at -129° and solidified at -130.5° . Pure ether solidifies at -129° .

Water containing a salt dissolved always solidifies below zero; the depression of the freezing point is proportional to the weight of salt dissolved, at any rate for weak solutions. This is known as *Blagden's law*.

If several salts which have no chemical action on each other be dissolved in a given weight of water, the lowering of the freezing point is the sum of the depressions which each of them would produce separately if dissolved in the same quantity of water.

When the numbers observed in any experiment of this kind do not agree with those calculated, this points to the occurrence of some chemical action

between the substances dissolved, and the observation of such deviations has been of use in questions of chemical statics.

The elaborate researches of Raoult on the temperature of solidification of solutions of bodies in water and other solvents have led to important conclusions. The temperature at which a solution solidifies, or its freezing point, is always lower than that of the pure solvent. If P is the weight in grammes of any substance dissolved in 100 grammes of a solvent, and C is the depression in the freezing point observed,

then $\frac{C}{P} = A$ is the depression which

would be produced by dissolving *one* gramme of the substance in 100 grammes of the solvent, and is known as the *coefficient of depression*.

A comparison of the values for A for various substances and the same solvent shows that they differ considerably; this is not so if we compare the depressions produced by molecular weights of the substances. That is, if we multiply the value of A in the above equation by M , the molecular weight of the substance dissolved, we obtain the depression which would be produced by dissolving one gramme-molecule of a body in 100 grammes of the solvent, or the *coefficient of molecular depression*; this is called T , and we have $T = \frac{CM}{P}$.

Now it is found that in a very large number of cases the value of T , for one and the same solvent, is a constant number; it has the value 19 for water, 39 for glacial acetic acid, and 49 for benzene.

This relation is of great value; by means of a simple determination of the freezing point of a solution we can calculate the molecular weight of many substances which cannot be obtained in the gaseous state without being decomposed. This is conveniently effected by means of the apparatus represented in fig. 335.

The solvent is contained in the vessel A , and the substance to be investigated is introduced by the lateral aperture A' . A is surrounded by a wide

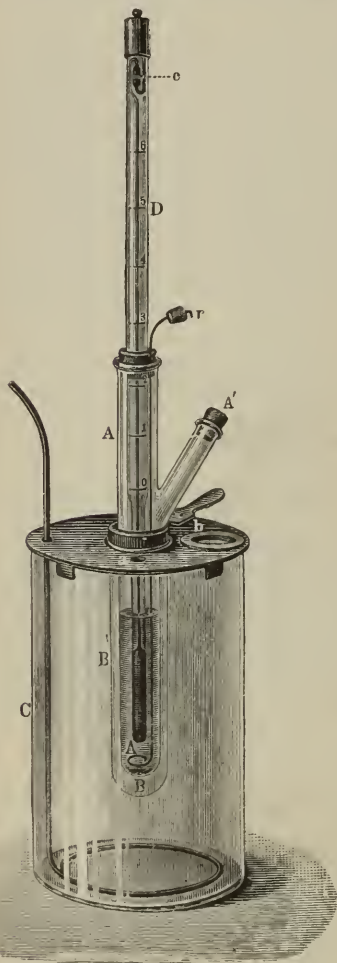

Fig. 335

glass tube B containing air, and this again is placed in a wider vessel C which contains the freezing mixture; for experiments with benzene or glacial acetic acid as a solvent, this is bruised ice, and with water a mixture of ice and salt. The liquid from these may be drawn off by a siphon placed through *b*. In A is a platinum stirrer *r*, and a delicate thermometer D, indicating the $\frac{1}{100}$ of a degree. There is also a stirrer in the outer vessel.

Since C and P are known, M is determined from the formula

$$M = \frac{PT}{C},$$

where T is the constant for the particular solvent employed, which is ordinary glacial acetic acid in the majority of cases.

Van 't Hoff has shown that the coefficient of depression C may be calculated by means of the formula $C = \frac{0.02T^2}{\omega}$, where ω is heat of fusion, and T the absolute temperature of fusion.

The above law holds only for indifferent (organic) substances. In the case of weak solutions of salts and bases and of the strong acids the molecular depressions are greater than is required by the law, being nearly twice as much as in indifferent bodies like sugar; this is probably due to the fact that a greater or less proportion of the salt is *dissociated* into its constituents, a phenomenon analogous to the dissociation of vapours, to which are due abnormal vapour densities (394).

347. **Crystallisation.**—Generally speaking, bodies which pass slowly from the liquid to the solid state assume regular geometrical forms, such as the cube, prism, rhombohedron, &c.; these are called *crystals*. If the crystals are formed from a body in fusion, such as sulphur or bismuth, the crystallisation is said to take place by the *dry way*. The crystallisation is said to be by the *moist way* when it takes place owing to the slow evaporation of a solution of a salt, or when a solution saturated at a higher temperature is allowed to cool slowly. Snow, ice, and many salts present examples of crystallisation.

Crystallisation bears the same relation to solution that solidification does to fusion. The latent heat of solution, *i.e.* the heat required to effect the solution of a substance without change of temperature, is restored during the reverse process of crystallisation.

348. **Retardation of the point of solidification.**—The freezing point of pure water can be diminished by several degrees, if the water is previously freed from air by boiling and is then kept in a perfectly still place. In fact, it may be cooled to -15° C., and even lower, without freezing. But when it is slightly agitated, the liquid, or a part of it, at once solidifies. This may be conveniently shown by means of the apparatus represented in fig. 336, which consists of a delicate thermometer, round the bulb of which is a wider bulb containing some water. Before sealing at *a* the whole outside bulb is filled with water, which is then boiled out, and sealed so that over the water the space is quite empty of air. The tube is

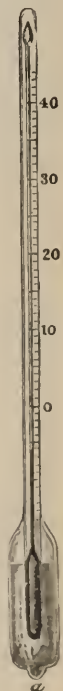

Fig. 336

clamped in a retort stand, and ether is dropped on it, that which has dropped off, and become colder, being used over and over again. In this way the temperature may soon be reduced to -6° , and if then the bulb is shaken, part of the water freezes and the temperature rises to zero. The smaller the quantity of liquid, the lower is the temperature to which it can be cooled, and the greater the mechanical disturbance it supports without freezing. Fournet has observed the frequent occurrence of mists formed of particles of liquid matter suspended in an atmosphere whose temperature was 10° or even 15° below zero.

A very rapid agitation prevents the formation of ice. This is also the case with all actions which, hindering the molecules in their movements, do not permit them to arrange themselves in the conditions necessary for the solid state. Despretz was able to lower the temperature of water contained in fine capillary tubes to -20° without their solidifying. This experiment shows how it is that plants in many cases do not become frozen even during severe cold, as the sap is contained in very fine capillary vessels.

As we have already seen, the freezing point of water containing salts in solution is lowered. Sea water freezes at -2.5° to -3° C.; the ice which forms is quite pure, and a saturated solution remains. In Finland advantage is taken of this property to concentrate sea water for the purpose of extracting salt from it. If water contains alcohol, precisely analogous phenomena are observed; the ice formed is pure, and practically all the alcohol is contained in the residue.

Dufour has observed some very curious cases of liquids cooled out of contact with solid bodies. His mode of experimenting was to place the liquid in another of the same specific gravity but of lower freezing point, in which it is insoluble. Drops of water, for instance, suspended in a mixture of chloroform and oil, usually solidified between -4° and -12° , while still smaller globules cooled down to -18° or -20° . Contact with a fragment of ice immediately set up congelation. Globules of sulphur (which solidifies at 115°) remained liquid at 40° ; and globules of phosphorus (solidifying point 42°) at 20° .

The superfusion of phosphorus may be illustrated by the experiment represented by fig. 337. A long test tube containing phosphorus, A, and covered with a layer of water, is fixed along with a thermometer T in a large flask containing water. This flask is raised to a temperature a few degrees above the melting point of phosphorus, and is then withdrawn from the source of heat; as its

mass is considerable, the phosphorus cools very slowly, and remains liquid at temperatures far below its ordinary point of solidification. A glass rod

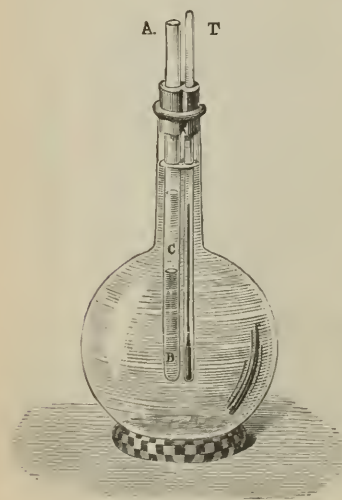

Fig. 337

may even be dipped into it without change; but if the liquid is touched with the smallest fragment of solid phosphorus, it instantaneously solidifies, and in so doing contracts and becomes opaque.

When a liquid solidifies after being cooled below its normal freezing point the solidification takes place very rapidly, and is accompanied by a disengagement of heat, which is sufficient to raise its temperature from the point at which solidification begins up to its ordinary freezing point. This is well seen in the case of sodium sulphate (Glauber's salt = $\text{Na}_2\text{SO}_4 \cdot 10\text{H}_2\text{O}$), which melts in its own water of crystallisation at about 45° , and when carefully cooled will remain liquid at the ordinary temperature of the atmosphere. If it is then made to solidify by agitation, or by adding a small fragment of the solid salt, the rise of temperature is distinctly felt by the hand. In this case the heat, which had become latent in the process of liquefaction, again becomes free, and a portion of the substance remains melted; for it is kept liquid by the heat of solidification of that which has solidified.

349. Change of volume on solidification and liquefaction.—The rate of expansion of bodies generally increases as they approach their melting points, and is in most cases followed by a further expansion at the moment of liquefaction, so that the liquid occupies a greater volume than the solid from which it is formed. The apparatus represented in fig. 338 is well adapted for exhibiting this phenomenon. It consists of a glass tube, *ab*, containing water or some other suitable liquid, to which is carefully fitted a cork with a graduated glass tube *c*. This forms, in fact, a thermometer, and the values of the divisions on the tube *c* are determined in terms of the capacity of the whole apparatus. A known volume of the substance is placed in the tube *aa* and the cork inserted; the apparatus is then placed in a space at a temperature very little below the melting point of the body in question, until it has acquired its temperature, and the position of the liquid in *c* is noted. The temperature is then allowed to rise slowly, and the position noted when the melting is complete. Knowing then the difference in the two readings and the volume of the substance under experiment, and making a correction for the expansion of the liquid and of the glass, it is easy to deduce the increase due to the melting alone. Phosphorus, for instance, increases about 3.4 per cent. on liquefaction; that is, 100 volumes of solid phosphorus at 44° (the melting point) become 103.4 at the same temperature when melted. Sulphur expands about 5 per cent. on liquefying, and stearic acid about 11 per cent.

The apparatus represented in fig. 338A is well adapted for showing the change of volume of a substance on changing from the liquid to the solid condition. A convenient substance to use is diphenylamine, a white crystalline solid which melts at 54°C . A tube, AB, about 10 cm. long and 2 cm. diameter, has a long lateral tube, 2 mm. diameter, fused into the upper part of it. Diphenylamine occupies the lower part of the tube AB, which is filled up with water and closed by a cork, the water rising in the lateral tube. A thermometer passing air-tight through the cork gives the temperature of the diphenylamine. The experiment may



Fig. 338

be conducted as follows : first thoroughly melt the diphenylamine by putting the whole apparatus in water at 60° or 70° ; remove from the hot water and allow to cool slowly. The substance will not solidify at 54° , but will remain in a superfused condition down to a temperature of about 42° . Note the temperature and the position of *a*. If B is now dipped into cold water crystallisation of the diphenylamine will commence, the temperature will rise, and the volume of the diphenylamine will decrease, as will be shown by the rapid descent of the water surface *a*. The temperature will rise to 48° or 49° . This experiment shows (1) the phenomenon of superfusion, (2) the decrease of volume on solidification, and (3) the heat evolved during the change of state.

Water presents a remarkable exception to the general rule ; it expands at the moment of solidifying, or contracts on melting, by about 10 per cent. One volume of ice at 0° gives 0.9178 of water at 0° , or 1 volume of water at 0° gives 1.102 of ice at the same temperature. In consequence of this expansion, ice floats on the surface of water. According to Dufour, the specific gravity of ice at 0° is 0.9178 ; Bunsen found for ice which had been made from water freed from air by boiling the somewhat smaller number 0.91674.

The increase of volume in the formation of ice is accompanied by an expansive force which sometimes produces powerful mechanical effects, of which the bursting of water-pipes and the breaking of jugs containing water are familiar examples. The splitting of stones, rocks, and the swelling up of moist ground during frost, are caused by the fact that water penetrates into the pores and there becomes frozen ; in short, the great expansion of water on freezing is the most active and powerful agent of disintegration on the earth's surface.

The expansive force of ice was strikingly shown by some experiments of Major Williams in Canada. Having quite filled a 13-inch iron bomb-shell with water, he firmly closed the touch-hole with an iron plug weighing 3 pounds and exposed it in this state to the frost. After some time the iron plug was forced out with a loud explosion, and thrown to a distance of 415 feet, and a cylinder of ice 8 inches long issued from the opening. In another case the shell burst before the plug was driven out, and in this case a sheet of ice spread out all round the crack (fig. 339). It is probable that under the great pressure some of the water still remained liquid (342) up to the time at which the resistance was overcome ; that it then issued from the shell in a liquid

state, but at a temperature below 0° , and therefore instantly began to solidify

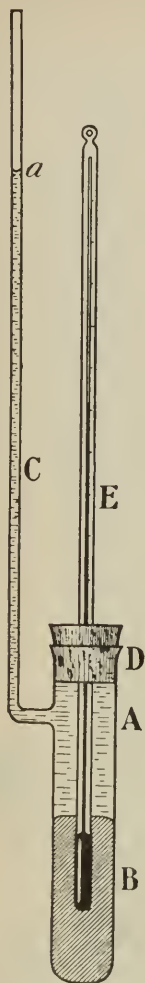

Fig. 338A



Fig. 339

when the pressure was removed, and thus retained the shape of the orifice whence it issued.

Many plans have been proposed to prevent the bursting of water-pipes in houses in severe weather. One plan is to empty the pipes, another to allow a slow leakage through the taps; a third method is to introduce into the exposed pipe a piece of india-rubber tubing securely closed at each end. C. V. Boys suggested making a portion of the leaden water-pipe of oval instead of circular section. Since the area of a circle is for a given circumference greater than the area of any other curve, the effect of expansion due to freezing would be to force the oval more or less into a circular form.

Cast iron, bismuth, and antimony expand on solidifying, like water, and can thus be used for casting; but gold, silver, and copper contract, and hence coins of these metals cannot be cast, but must be stamped with a die.

An iron tube filled with molten bismuth and closed by a screw is broken as the bismuth becomes solid.

This increase of volume when liquids solidify, and the correlated decrease on melting again, in the case of water and some other crystalline substances such as bismuth, are probably due to the fact that such bodies are aggregates of small crystalline masses, which are grouped in such a way that small interstices are formed. When the liquid melts these interstices fill up owing to the mobility of the molecules, and, notwithstanding the greater space which each individual group takes up, owing to expansion, there is on the whole a decrease of volume.

350. Freezing mixtures.—The absorption of heat in the passage of bodies from the solid to the liquid state has been used to produce artificial cold. This is effected by mixing together bodies which have an affinity for each other, and of which one at least is solid, such as water and a salt, ice and a salt, or an acid and a salt. Chemical affinity accelerates the fusion or solution; the portion which melts or dissolves robs the rest of the mixture of a large quantity of sensible heat, which thus becomes latent. In many cases a very considerable diminution of temperature is produced.

The following table gives the names of the substances mixed, their proportions, and the corresponding diminutions of temperature:—

Substances	Parts by Weight	Reduction of Temperature
Sodium sulphate	8	+ 10° to - 17°
Hydrochloric acid	5	
Pounded ice or snow	2	+ 10° to - 18°
Common salt	1	
Sodium sulphate	3	+ 10° to - 19°
Dilute nitric acid	2	
Sodium sulphate	6	+ 10° to - 26°
Ammonium nitrate	5	
Dilute nitric acid	4	
Sodium phosphate	9	
Dilute nitric acid	4	+ 10° to - 29°

If the substances taken are previously cooled, a still more considerable diminution of temperature is occasioned.

Freezing mixtures are frequently used in chemistry, in physics, and in domestic economy. One form of the portable ice-making machines which have come into use during the last few years consists of a cylindrical metallic vessel divided into four concentric compartments. In the central one is placed the water to be frozen; in the next there is the freezing mixture, which usually consists of sulphate of sodium and hydrochloric acid; 6 pounds of the former and 5 of the latter will make 5 to 6 pounds of ice in an hour. The third compartment also contains water, and the outside one contains some badly conducting substance, such as cotton, to cut off the influence of the external temperature. The best effect is obtained when fairly large quantities (2 or 3 pounds) of the mixture are used, and when the ingredients are intimately mixed. It is also advantageous to use the machines for a succession of operations.

351. **Guthrie's researches.**—It appears from the experiments of the late Dr. Guthrie that what are called freezing mixtures may be divided into two classes—namely, those in which one of the constituents is liquid and those in which both are solid. The quantity of heat absorbed by the freezing mixture is obviously the heat required to melt the constituents, together with (\pm) the heat of combination of the constituents. When one constituent is liquid, as when hydrochloric acid is added to ice, then a lower temperature is got by previously cooling the hydrochloric acid. There is no advantage in cooling the ice. But when both constituents are solid, as in the case of the ice-salt freezing mixture, there is no advantage to be gained by cooling one or both constituents. Within very wide limits it is also in the latter case a matter of indifference as to the ratio between the constituents. Nor is it important whether the ice is finely powdered as snow or in pieces as large as a pea.

The different powers of various salts when used in conjunction with ice as freezing mixtures appear to have remained unexplained until Guthrie showed that, with each salt, there is always a minimum temperature below which it is impossible for an aqueous solution of any strength of that salt to exist in the liquid form; that there is a certain strength of solution for each salt which resists solidification the longest, that is, to the lowest temperature. Weaker solutions give up ice on being cooled, stronger solutions give up the salt either in the anhydrous state or in combination with water. A solution of such a strength as to resist solidification to the lowest temperature was called by Guthrie a *cryohydrate*. It is of such a strength that when cooled below 0° C. it solidifies as a whole; that is, the ice and the salt solidify together and form crystals of constant composition and constant melting and the same solidifying temperatures. The liquid portion of a freezing mixture, as long as the temperature is at its lowest, is, indeed, a melted cryohydrate. The slightest depression of temperature below this causes solidification of the cryohydrate, and hence the temperature can never sink below the solidifying temperature of the cryohydrate.

Guthrie also showed that colloid bodies, such as gum and gelatine, neither raise the boiling point of water nor depress the solidifying point, nor can they act as elements in freezing mixtures.

VAPOURS. MEASUREMENT OF THEIR PRESSURE

352. **Vapours.**—*Vapours* are the æriform fluids into which volatile substances, such as ether, alcohol, water, and mercury, are changed by the absorption of heat. *Volatile liquids* are those which thus possess the property of passing into the æriform state, and *fixed liquids* are those which do not form vapour at any temperature without undergoing chemical decomposition, such as the fatty oils. Ice and snow volatilise in closed spaces, forming crystals on the cooled parts.

Some substances—arsenious acid (white arsenic) for example—vaporise, when heated under atmospheric pressure, without passing through the liquid condition. This process is called sublimation. In the case of arsenious acid, if the pressure is doubled the substance first liquefies and then passes into vapour. It is a question of vapour pressure (359); if the vapour pressure is less than the pressure to which the substance is exposed, liquefaction takes place; but if the vapour pressure is greater than this, the substance cannot exist in a liquid state. The vapour pressure of arsenious acid is greater than 1 and less than 2 atmospheres. Iodine melts at 104° and boils at 200° under ordinary pressure, since its vapour pressure is less than 760 mm. mercury; but if the pressure be reduced to 250 mm. the solid iodine passes direct into the vaporous state. In these conditions it is sometimes said that the boiling point of iodine is below its melting point.

Vapours are transparent, like gases, and generally colourless; some few coloured liquids give rise to coloured vapours.

353. **Vaporisation.**—The passage of a liquid into the gaseous state is designated by the general term *vaporisation*; the term *evaporation* especially refers to the slow production of vapour at the free surface of a liquid, and *boiling* to its rapid production in the mass of the liquid itself. We shall presently see (366) that at the ordinary atmospheric pressure, ebullition, like fusion, takes place at a definite temperature. This is not the case with evaporation, which occurs even with the same liquid at very different temperatures, although the formation of a vapour seems to cease below a certain point. Mercury, for example, is stated to give no vapour below -10° , nor sulphuric acid below 30° .

354. **Elastic force of vapour. Vapour pressure.**—Like gases, vapours have a certain elastic force, in virtue of which they exert pressures on the sides of vessels in which they are contained. The fact of vapour pressure may be demonstrated by the following experiment:—A quantity of mercury is placed in a bent glass tube (fig. 340), the shorter leg of which is closed; a few drops of ether are then passed into the closed leg and the tube is immersed in a water bath at a temperature of about 45° . The mercury then sinks slowly in the short branch, and the space *ab* is filled with a gas which has all the appearance of air, and whose elastic force counterbalances the pressure of the column of mercury *cd*, and the atmospheric pressure on *d*. This gas is the vapour of ether. If the water is cooled, or if the tube is removed from the bath, the vapour which fills the space *ab* disappears, and the drop of ether is reproduced. If, on the contrary, the bath is heated still higher, the level of the mercury descends below *b*, indicating an increase in the pressure of the vapour.

A gaseous substance, strictly speaking, is called a vapour when it can be liquefied by increase of pressure alone, without change of temperature; the substance is a gas when it cannot be so liquefied. As we shall see later, whether a substance is a gas or a vapour depends on its temperature. The substance is a vapour or a gas according as its temperature is below or above its critical temperature (373).

355. **Formation of vapour in a vacuum.**—The change from liquid to vapour takes place very slowly when the liquid is freely exposed to the air.

The atmosphere is an obstacle to the vaporisation. In a vacuum there is no resistance, and the formation of vapour is instantaneous, as is seen in the following experiment:—Four barometer tubes, filled with mercury, are immersed in the same trough, fig. 341. One of them, A, serves as a barometer, and a few drops of water, alcohol, and ether are respectively introduced into the tubes B, C, D. When the liquids reach the vacuum, a depression of the mercury is at once produced. And as this depression cannot be caused by the weight of the liquid, which is an extremely small fraction of the weight of the displaced mercury, it must be due to the formation of some vapour whose elastic force has depressed the column of mercury.

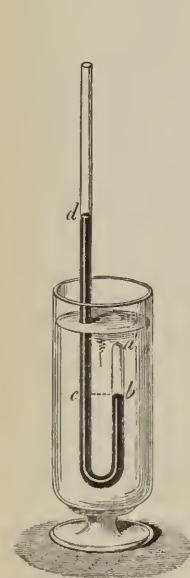

Fig. 340

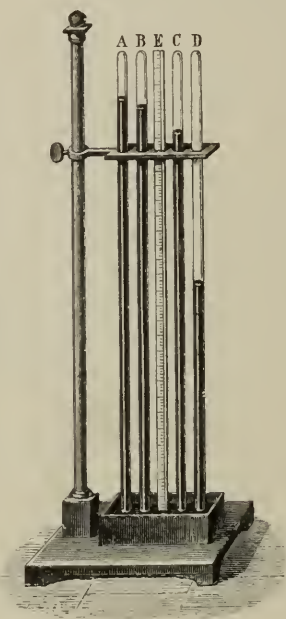

Fig. 341

The experiment also shows that the depression is not the same in all the tubes; it is greater in the case of alcohol than of water, and greater again with ether than with alcohol. We consequently obtain the two following laws of the formation of vapours:—

I. *In a vacuum all volatile liquids are immediately converted into vapour.*
 II. *At the same temperature the vapours of different liquids have different pressures.*

For example, at 20° the pressure of ether vapour is 25 times as great as that of aqueous vapour.

356. **Saturated vapour. Maximum of pressure.**—When a very small quantity of a volatile liquid, such as ether, is introduced into a barometer tube, it is at once completely vaporised, and the column of mercury is not depressed to its full extent; for if some more ether be introduced

the depression increases. The ether, if still more be added, finally ceases to vaporise, and remains in the liquid state. There is, therefore, for a certain temperature, a limit to the quantity of vapour which can be formed in a given space. This space is accordingly said to be *saturated*. Further, when the vaporisation of the ether ceases, the depression of the mercurial column stops. And hence there is a limit to the pressure of the vapour, a limit which, as we shall presently see (358), varies with the temperature.

To show that, in a closed space, saturated with vapour and containing liquid *in excess*, the temperature remaining constant, there is a *maximum of pressure* which the vapour cannot exceed, a barometric tube is used which dips in a deep bath (fig. 342). This tube is filled with mercury, and then so much ether is added as to be in excess after the Torricellian vacuum is saturated. The height of the column of mercury is next noted by means of the scale graduated on the tube itself. Now, whether the tube be depressed, which tends to compress the vapour, or whether it be raised, which tends to expand it, the height of the column of mercury is constant. The pressure of the vapour remains constant in the two cases, for the depression neither increases nor diminishes it. Hence it is concluded that when the volume of the saturated vapour is diminished, a portion of the vapour returns to the liquid state; that when, on the other hand, the volume is increased, a portion of the excess of liquid vaporises, and the space occupied by the vapour is again saturated; but in both cases the pressure and the density of the vapour remain constant.

The maximum pressure is called the saturation pressure of the vapour corresponding to the particular temperature. If the vapour pressure of a liquid is spoken of without qualification, the maximum pressure is generally meant.

357. Unsaturated vapours.—It will be seen from what has been said, that vapours present two very different states, according as they are saturated or not. In the first case, where they are saturated and in contact with the liquid, they differ completely from gases, since for a given temperature their pressure and density are constant and independent of their volume.

In the second case, on the contrary, where they are not saturated, they exactly resemble gases. For if the experiments (fig. 342) are repeated, only a small quantity of ether being introduced, so that the vapour is not saturated, and if the tube is then slightly raised, the level of the mercury is seen to rise, which shows that the pressure of the vapour has diminished. Similarly, by immersing the tube still more, the level of the mercury sinks.

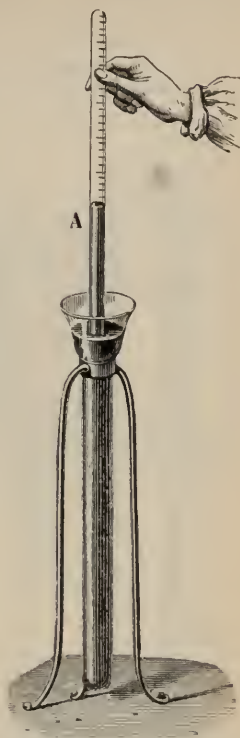

Fig. 342

The vapour consequently behaves just as a gas would do, its pressure diminishing when the volume increases, and *vice versa*; and as in both cases the volume of the vapour is inversely as the pressure, it is concluded that *unsaturated vapours obey Boyle's law*.

When an unsaturated vapour is heated, its volume increases like that of a gas; and the number 0.00367, which is the coefficient of the expansion of air, may be taken for that of unsaturated vapours.

Hence we see that the physical properties of unsaturated vapours are comparable with those of gases, and that the formulæ for the compressibility and expansibility of gases (181 and 333) also apply to unsaturated vapours.

358. Pressure of aqueous vapour below zero.

In order to measure the pressure of aqueous vapour below zero, Gay-Lussac used two barometer tubes filled with mercury, and placed in the same reservoir (fig. 343). The straight tube, A, serves as a barometer; the other, C, is bent, so that part of the Torricellian vacuum can be surrounded by a freezing mixture, B (350). When a little water is admitted into the bent tube, the level of the mercury sinks below that in the tube A, to an extent which varies with the temperature of the freezing mixture.

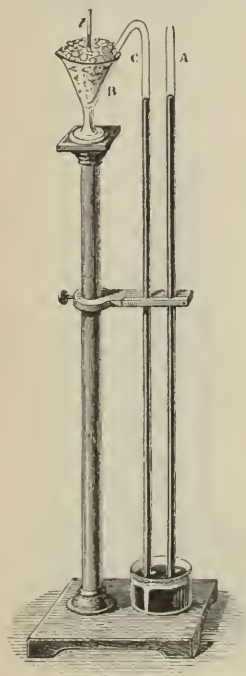

Fig. 343

At	0°	the depression is .	4.54	millimetres
”	- 1°	”	4.25	”
”	- 3°	”	3.63	”
”	- 5°	”	3.11	”
”	- 7°	”	2.67	”
”	- 10°	”	2.08	”
”	- 20°	”	0.84	”
”	- 30°	”	0.36	”

These depressions, which must be due to the pressure of aqueous vapour in the space BC, show that even at very low temperatures there is always some aqueous vapour in the atmosphere.

Although in the above experiment the part B and the part C are not *both* immersed in the freezing mixture, we shall presently see that when two communicating vessels are at different temperatures, the pressure of the vapour is the same in both, and always corresponds to that of the lower temperature.

359. Pressure of aqueous vapour between zero and one hundred degrees.—i. *Dalton's method.* Dalton measured the pressure of aqueous vapour between 0° and 100° by means of the apparatus represented in fig. 344. Two barometer tubes, A and B, are filled with mercury, and inverted in an iron bath full of mercury, which is placed on a furnace. The tube A contains a small quantity of water. The tubes are supported in a cylindrical vessel, open top and bottom and full of water, the temperature of which is

indicated by the thermometer. The bath being gradually heated, the water in the cylinder becomes heated too; the water which is in the tube A vaporises, and in proportion as the pressure of its vapour increases, the mercury sinks. The depressions of the mercury corresponding to each degree of the thermometer are indicated on the scale E, and in this manner a table of aqueous vapour pressures between zero and 100° has been constructed.

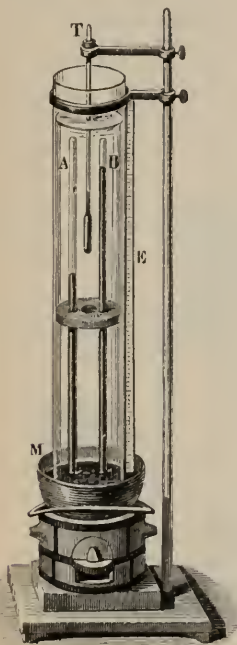

Fig. 344

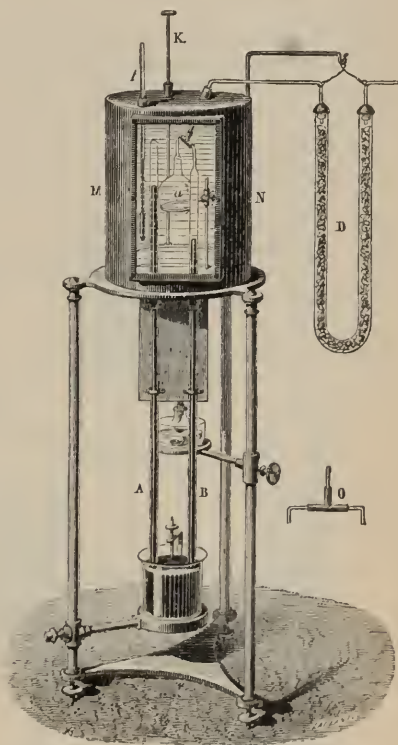

Fig. 345

ii. *Regnault's method.*—Dalton's method is wanting in precision, for the temperature of the liquid in the cylinder is not everywhere the same, and consequently the exact temperature of the aqueous vapour is not shown. Regnault's apparatus is a modification of that of Dalton. The cylindrical glass vessel is replaced by a large cylindrical zinc drum, MN (fig. 345), in the bottom of which are two tubulures. The tubes A and B pass through these tubulures, and are fixed by india-rubber collars. The tube containing vapour, B, is connected with a flask, *a*, by means of a brass three-way tube, O. The third limb of this tube is connected with a drying tube, D, containing pumice charged with sulphuric acid, which is connected with the air-pump.

When the flask *a* contains some water, a small portion is distilled into B by gently heating the flask. Exhausting, then, by means of the air-pump, the water distils continuously from the flask and from the barometric tube towards D, which condenses the vapour. After having vaporised some quantity of water, and when it is thought that the air in the tube is withdrawn, the capillary tube which connects B with the three-way tube is sealed. The tube B being thus closed, it is experimented with as in Dalton's method.

The drum, MN, being filled with water, is heated by a spirit lamp, which is screened from the tubes by a wooden board. By means of a stirrer, K, all parts of the liquid are kept at the same temperature. In the side of the drum is a glass window, through which the height of the mercury in the tubes can be read off by means of a cathetometer; from the difference in these heights, reduced to zero, the pressure of the vapour is deduced. By means of this apparatus, the elastic force of vapour between 0° and 50° has been determined with accuracy.

360. Pressure of aqueous vapour above 100° C.—Two methods have principally been employed for determining the pressure of aqueous vapour at temperatures above 100° ; the one by Dulong and Arago in 1830, and the other by Regnault in 1844.

Fig. 346 represents a vertical section of the apparatus used by Dulong and Arago. It consisted of a copper boiler, *k*, with very thick sides, and of

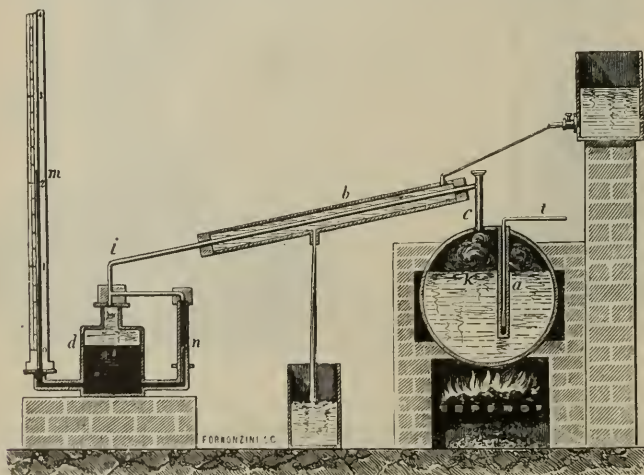

Fig. 346

about 20 gallons' capacity. Two gun-barrels, *a*, of which only one is seen in the drawing, were firmly fixed in the sides of the boiler, and plunged in the water. The gun-barrels were closed below, and contained mercury, in which were placed thermometers, *t*, indicating the temperature of the water and of the vapour. The pressure of the vapour was measured by means of a manometer with compressed air, *m*, previously graduated (185) and fitted into an iron vessel, *d*, filled with mercury. In order to see the height of the

mercury in the vessel, it was connected above and below with a glass tube, *n*, in which the level was always the same as in the bath. A copper tube, *i*, connected the upper part of the vessel, *d*, with a vertical tube, *c*, fitted in the boiler. The tube *i* and the upper part of the bath *d* were filled with water, which was kept cool by means of a current of cold water flowing from a reservoir, and circulating through the tube *b*.

The vapour which was disengaged from the tube *c* exerted a pressure on the water of the tube *i*; this pressure was transmitted to the water and to the mercury in the bath *d*, and the mercury rose in the manometer. By noting on the manometer the pressures corresponding to each degree of the

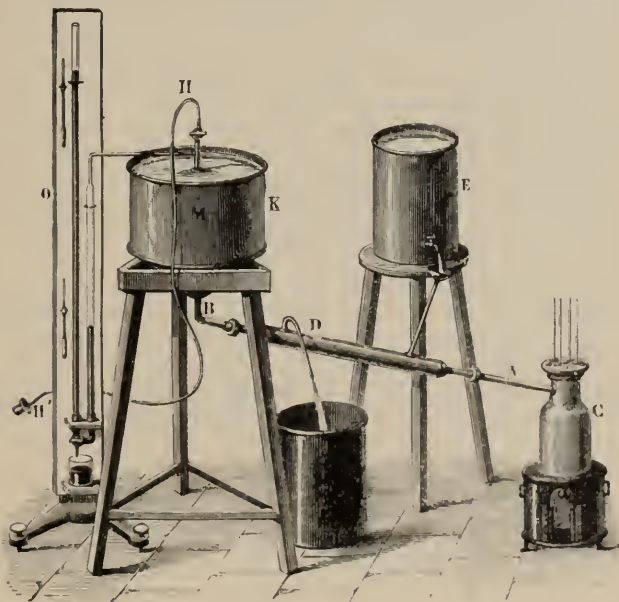

Fig. 347

thermometer, Dulong and Arago were able to make a direct measurement of the pressure up to 24 atmospheres, and the pressure to 50 atmospheres was determined by calculation.

361. **Pressure of vapour below and above 100° C.**—Regnault devised a method by which the pressure of vapour may be measured at temperatures either below or above 100° . It depends on the principle that when a liquid boils, the pressure of the vapour is equal to the pressure the liquid supports. If, therefore, the temperature and the corresponding pressure are known, the question is solved, and the method merely consists in causing water to boil in a vessel under a given pressure, and measuring the corresponding temperature.

The apparatus consists of a copper retort, C (fig. 347), hermetically closed and about two-thirds full of water. In the cover are four thermometers,

two of which just dip into the water, and two descend almost to the bottom. By means of a tube, AB, the retort C is connected with a glass globe, M, of about 6 gallons' capacity, and full of air. The tube AB passes through a metal cylinder, D, through which a current of cold water is constantly flowing from the reservoir E. To the upper part of the globe a tube with two branches is attached, one of which is connected with a manometer, O; the other tube, HH', which is of lead, can be attached to either an exhausting or a condensing air-pump, according as the air in the globe is to be rarefied or condensed. The reservoir K, in which is the globe, contains water at the temperature of the surrounding air.

If the elastic force of aqueous vapour below 100° is to be measured, the end H' of the lead pipe is connected with the plate of the air-pump, and the air in the globe M, and consequently that in the retort C, is rarefied. The retort being gently heated, the water begins to boil at a temperature below 100° , in consequence of the diminished pressure. And since the vapour is condensed in the tube AB, which is always cool, the pressure originally indicated by the manometer does not increase, and therefore the pressure of the vapour during ebullition remains equal to the pressure on the liquid.

A little air is then allowed to enter; this alters the pressure, and the liquid boils at a new temperature; both these are read off, and the experiment repeated as often as desired up to 100° .

In order to measure the pressure above 100° , the tube H' is connected with a condensing pump, by means of which the air in the globe M and that in the vessel C are exposed to successive pressures, higher than the atmosphere. The ebullition is retarded (370), and it is only necessary to observe the difference in the height of the mercury in the two tubes of the manometer O, and the corresponding temperature, in order to obtain the pressure for a given temperature. The following table by Regnault gives the pressure of aqueous vapour from -10° to 104° .

Pressures of aqueous vapour from -10° to 104° C.

Temperatures	Pressure in millimetres	Temperatures	Pressure in millimetres	Temperatures	Pressure in millimetres	Temperatures	Pressure in millimetres
-10°	2.078	12°	10.457	29°	29.782	90°	525.45
8	2.456	13	11.062	30	31.548	91	545.78
6	2.890	14	11.906	31	33.405	92	566.76
4	3.387	15	12.699	32	35.359	93	588.41
2	3.955	16	13.635	33	37.410	94	610.74
0	4.600	17	14.421	34	39.565	95	633.78
+ 1	4.940	18	15.357	35	41.827	96	657.54
2	5.302	19	16.346	40	54.906	97	682.03
3	5.687	20	17.391	45	71.391	98	707.26
4	6.097	21	18.495	50	91.982	98.5	720.15
5	6.534	22	19.659	55	117.479	99.0	733.91
6	6.998	23	20.888	60	148.791	99.5	746.50
7	7.492	24	22.184	65	186.945	100.0	760.00
8	8.017	25	23.550	70	233.093	100.5	773.71
9	8.574	26	24.998	75	288.517	101.0	787.63
10	9.165	27	26.505	80	354.643	102.0	816.17
11	9.792	28	28.101	85	433.410	104.0	875.69

In the following table the numbers were obtained by direct observation up to 24 atmospheres ; the others were calculated by the aid of a formula of extrapolation. This table and the one next following show that the elastic force increases much more rapidly than the temperature. It has been attempted to express the relation between them by formulæ, but none of the formulæ seems to have the simplicity which characterises a true law.

Pressures in atmospheres from 100° to 230°9'

Temperatures	Number of atmospheres	Temperatures	Number of atmospheres	Temperatures	Number of atmospheres	Temperatures	Number of atmospheres
100°0'	1	170°8'	8	198°8'	15	217°9'	22
112°2'	1½	175°8'	9	201°9'	16	220°3'	23
120°6'	2	180°3'	10	204°9'	17	222°5'	24
133°9'	3	184°5'	11	207°7'	18	224°7'	25
144°0'	4	188°4'	12	210°4'	19	226°8'	26
152°2'	5	192°1'	13	213°0'	20	228°9'	27
159°2'	6	195°5'	14	215°5'	21	230°9'	28
165°3'	7						

362. **Pressure of the vapours of different liquids.**—Regnault determined the pressure, at various temperatures, of the vapours of a certain number of liquids which are given in the following table :—

Liquids	Temperatures	Pressures in millimetres	Liquids	Temperatures	Pressures in millimetres
Mercury .	0°	0·02	Ether . .	-20°	68
	50	0·11		0	182
	100	0·74		60	1728
Alcohol .	0	13	Sulphurous acid	100	4950
	50	220		-20	479
	100	1695		0	1165
Carbon bisulphide	-20	43	Ammonia .	60	8124
	0	132		-30	876
	60	1164		0	3163
	100	3329		30	8832

363. **Pressure of the vapours of mixed liquids.**—Regnault's experiments on the pressure of the vapour of mixed liquids prove that (i.) when two liquids exert no solvent action on each other—such as water and *carbon bisulphide*, or water and *benzole*—the pressure of the vapour which rises from them is nearly equal to the sum of the pressures of the two separate liquids at the same temperature ; (ii.) with water and *ether*, which partially dissolve each other, the pressure of the mixture is much less than the sum of the pressures of the separate liquids, being scarcely equal to that of the ether alone ; (iii.) when two liquids dissolve in all proportions, as ether and bisulphide of carbon, or water and alcohol, the pressure of the vapour of the mixed liquids is intermediate between the pressures of the separate liquids.

The pressure of a vapour over a convex surface is slightly greater than over a plane one, as may be seen from the following considerations:—

When evaporation takes place from a plane surface there is no change in the area of the surface, but in the case of a liquid drop the surface diminishes by evaporation. Hence, evaporation will take place from the surface of a drop more readily than from a plane surface, for the drop will tend to reach a condition in which its potential energy is a minimum. Thus, in consequence of surface tension, the vapour pressure over a convex surface is greater than over a plane surface.

The pressure of the vapour from liquids which contain salts or other bodies in solution is less than that of the pure liquid. This may in principle be most simply demonstrated by an apparatus similar to that represented in fig. 344, in which B is a barometer into the vacuum of which the solution of a salt of known strength is introduced, while A is a similar barometer containing the pure liquid.

With solutions of one and the same salt, Wüllner found that at a given temperature the diminution of pressure is proportional to the quantity of salt dissolved, provided the solutions are dilute.

If f is the pressure of the pure solvent, and f' that of the solution, and g is the percentage strength, then $\frac{f-f'}{f} = kg$, where k is a constant. For $g = 1$, k equals $\frac{f-f'}{f}$, and is the relative diminution of pressure for one per cent.

This property is of great importance from the connection which has been established with osmotic pressure (139). The depression is different for different salts dissolved in the same solvent, but it is found that if these various solutions are *equimolecular*—that is, the weights dissolved in the same quantity of solvent are as their molecular weights—then the depression is constant. This may also be expressed by saying that the diminution in pressure stands in the same ratio to the pressure of the solvent, as the number of molecules in the dissolved body does to the total molecules in the liquid; that is

$$\frac{f-f'}{f} = \frac{n}{N+n},$$

where N and n are the number of molecules in the solvent and the salt respectively. Since $N = \frac{P}{M}$ and $n = \frac{\phi}{m}$, where P and ϕ are the weights, and M and m the molecular weights, of the solvent and salt respectively, the above equation gives

$$\frac{f-f'}{f} = \frac{\phi M}{\phi M + P m},$$

so that it is easy to deduce the molecular weight m of the body dissolved.

The above relations hold in strictness only for ideal solutions, or those which are so dilute that the volume of the substance is infinitely small in comparison with that of the solvent.

364. **Pressure in two communicating vessels at different temperatures.**—When two vessels containing the same liquid, but at different temperatures, are connected with each other, the elastic force is not that corresponding to the mean of the two temperatures, as might be supposed. Thus, if there are two globes (fig. 348), one, A, containing water kept at zero by means of melting ice, the other, B, containing water at 100° , the vapour pressure, as long as the globes are not connected, is 4.6 millimetres in the first, and 760 millimetres in the second. But when they are connected by opening the stopcock C, the vapour in the globe B, from its greater pressure, passes into the other globe, and is there

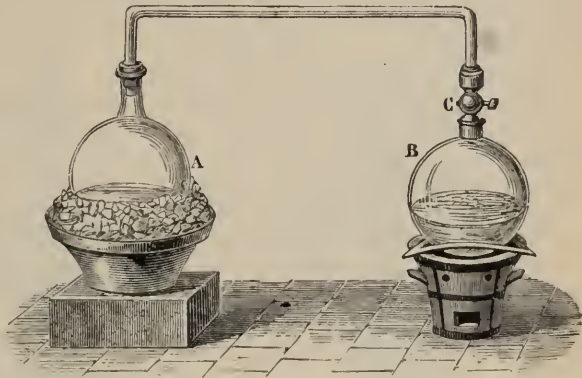

Fig. 348

condensed, so that the vapour in B can never reach a higher pressure than that in the globe A. The liquid simply distils from B towards A without any increase of pressure.

From this experiment the general principle may be deduced that *when two vessels containing the same liquid, but at different temperatures, are connected, the pressure is identical in both vessels, and is the same as that corresponding to the lower temperature.* An application of this principle has been made by Watt in the condenser of the steam-engine.

365. **Evaporation. Causes which accelerate it.**—*Evaporation*, as has been already stated (353), is the slow production of vapour at the surface of a liquid. It is in consequence of this evaporation that wet clothes dry when exposed to the air, and that open vessels containing water become empty. The vapours which, rising in the atmosphere, condense, and, becoming clouds, fall as rain, are due to evaporation from seas, lakes, rivers, and the earth.

Four causes influence the rapidity of the evaporation of a liquid : i. the temperature ; ii. the quantity of the same vapour in the surrounding atmosphere ; iii. the renewal of this atmosphere ; iv. the extent of the surface of evaporation.

Increase of temperature accelerates the evaporation by increasing the pressure of the vapour.

In order to understand the influence of the second cause, it is to be observed that no evaporation could take place in a space already saturated with vapour of the same liquid, and that it would reach its maximum in air completely freed from this vapour. It therefore follows that between these two extremes, the rapidity of evaporation varies according as the

surrounding atmosphere is already more or less charged with the same vapour.

The effect of the renewal of this atmosphere is similarly explained ; for if the air or gas, which surrounds the liquid, is not renewed, it soon becomes saturated, and evaporation ceases. Dalton found that the ratios of the evaporation in a feeble, medium, and strong draught were respectively as 270 : 347 : 424. He also observed that the quantity evaporated in perfectly dry, almost still air, at a temperature of 20°, was 0.1 of a gramme per square decimetre of a surface in a minute.

The effect of the fourth cause is self-evident.

Vegetation exercises a great influence on evaporation. Schübler found that the evaporation from a space covered with meadow grass, in the most vigorous stage of its growth, was thrice as rapid as that from an adjacent surface of water. As the plants ripened the evaporation diminished.

366. **Boiling.**—*Ebullition*, or *boiling*, is the rapid production of bubbles of vapour in the mass of a liquid itself.

When a liquid, water for example, is heated at the lower part of a vessel, the first bubbles are due to the disengagement of air which the water had previously absorbed, or which in the form of a thin film separates the liquid from the containing vessel. Small bubbles of vapour then begin to rise from the heated parts of the sides, but as they pass through the upper layers, the temperature of which is lower, they condense before reaching the surface. The formation and successive condensation of these first bubbles occasion the *singing* sometimes noticed in liquids just before they begin to boil. Lastly, large bubbles rise and burst on the surface, and this constitutes the phenomenon of ebullition (fig. 349).

The laws of ebullition are as follows :—

I. *The temperature of ebullition or the boiling point increases with the pressure.*

II. *For a given pressure boiling begins at a certain temperature, which varies in different liquids, but which, for equal pressures, is always the same in the same liquid.*

III. *Whatever be the intensity of the source of heat, as soon as boiling begins the temperature of the liquid remains stationary.*

In order to determine the boiling points of liquids the apparatus represented in fig. 350 may be used. It consists of a bulb with long neck to which is fused the tube *b* ; *a* can be connected either with a reflex or an ordinary condenser ; the condensed vapours collect in the bent part *b*, and flow thence into the bulb. The temperature is indicated by a delicate thermometer *k* passing through the cork, in which there is also a capillary glass tube β ; this serves to admit a few bubbles of air from time to time, and materially prevents bumping, which is likewise prevented by a few scraps of platinum foil placed in the bulb. When the boiling point is to be determined under diminished pressure, *a* can be connected with an air-pump.

This apparatus in suitable dimensions may also be used to determine the expansion of a liquid between a given temperature and the boiling point of the liquid. For this purpose a bent tube of small diameter with a bulb at the end serving the purpose of a specific gravity bottle is suspended from a wire, γ ,

which passes through the cork. This is weighed after having been filled with the liquid at a given temperature, and is then kept for some time in the vapour



Fig. 349

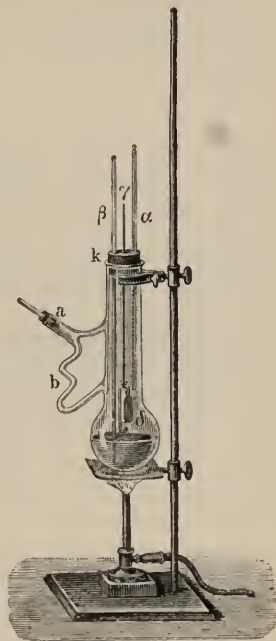

Fig. 350

of the boiling liquid at the temperature t' , and then when cooled is weighed again ; the difference in the two weights represents the expansion between the two temperatures t and t' .

Boiling points under the pressure of 760 millimetres

Fluorine	- 187°	Methylic alcohol	+ 66°
Oxygen	- 181.4	Alcohol	78
Nitrous oxide	- 92	Benzole	81
Carbonic acid	- 80	Distilled water	100
Ammonia	- 39	Acetic acid	117
Methyl chloride	- 23	Amylic alcohol	131
Cyanogen	- 20	Propionic acid	137
Sulphurous acid	- 10	Butyric acid	156
Ethyl chloride	+ 11	Turpentine	157
Aldehyde	21	Methylene iodide	182
Ether	37	Aniline	184
Carbon bisulphide	47	Iodine	200
Acetone	56	Naphthaline	218
Bromine	58	Diphenyl	254

Benzoic acid	+ 261°	Phenyl phosphate	+ 407°
Phosphorus	290	Arsenic	437
Diphenylamine	310	Sulphur	444
Strong sulphuric acid	318	Phosphorus pentasulphide	530
Phenanthrene	340	Selenium	665
Mercury	357	Cadmium	756
Zinc			916°

Kopp pointed out that in homologous chemical compounds the same difference in chemical composition frequently involves the same difference of boiling points; and he showed that in an extensive series of compounds, the fatty acids for instance, the difference of CH_2 is attended by a difference of 19°C . in the boiling point. In other series of homologous compounds, the corresponding difference in the boiling point is 30° , and in others again 24° .

367. **Theoretical explanation of evaporation and ebullition.**—From what has been said about the nature of the motion of the molecules in liquids (294), it may readily be conceived that in the great variety of these motions, the case occurs in which, by a fortuitous concurrence of the progressive, vibratory, and rotatory motions, a molecule is projected from the surface of the liquid with such force that it overleaps the sphere of the action of its circumjacent molecules, before, by their attraction, it has lost its initial velocity; and that it then flies into the space above the liquid.

Let us first suppose this space limited and originally vacuum; it gradually fills with the propelled molecules, which act like a gas and in their motion are driven against the sides of the envelope. One of these sides, however, is the surface of the liquid itself, and a molecule when it strikes against this surface will not in general be repelled, but will be retained by the attraction which the adjacent ones exert. Equilibrium will be established when as many molecules are dispersed in the surrounding space as, on the average, impinge against the surface and are retained by it in the unit of time. This state of equilibrium is not, however, one of rest, in which evaporation has ceased, but a condition in which evaporation and condensation, which are equally strong, continually compensate each other. The pressure is then the maximum vapour pressure of the liquid, which remains constant so long as the temperature is constant.

If the space above the liquid contains air or any other gas, evaporation goes on just the same as when the space is vacuum, except that it is slower. The final pressure reached is in no way modified by the presence of other gases or vapours.

What has been said respecting the surface of the liquid clearly applies to the other sides of the vessel within which the vapour is formed; some vapour is condensed, this is subject to evaporation, and a condition ultimately occurs in which evaporation and condensation are equal. The quantity of vapour necessary for this depends on the density of vapour in the closed space, on the temperature of the vapour and of the sides of the vessel, and on the force with which this attracts the molecules. The maximum will be reached when the sides are covered with a layer of liquid, which then acts like the free surface of a liquid.

368. **Influence of substances in solution on the boiling point.**—The ebullition of a liquid is the more retarded the greater the quantity of any substance it may contain in solution, provided that the substance be not volatile, or, at all events, be less volatile than the liquid itself. Water, which boils at 100° when pure, boils at the following temperatures when saturated with different salts :—

Water saturated with common salt . . .	boils at 102°
" " potassium nitrate . . .	" 116
" " potassium carbonate . . .	" 135
" " calcium chloride . . .	" 179

Acids in solution present analogous results ; but substances merely mechanically suspended, such as earthy matters, bran, wooden shavings, &c., do not affect the boiling point.

Absorbed air exerts a very marked influence on the boiling point of water. Deluc first observed that water freed from air by ebullition, and placed in a flask with a long neck, could be raised to 112° without boiling. Donny examined this phenomenon by means of the apparatus depicted in fig. 351. It consists of a glass tube CAB, bent at one end and closed at



Fig. 351

C, while the other is blown into a pear-shaped bulb, B, drawn out to a point. The tube contains water which is boiled until all air is expelled, and the open end is hermetically sealed. By inclining the tube the water passes into the bent end CA ; this end being placed in a bath of chloride of calcium, the temperature may be raised to 130° without any signs of boiling. At 138° the liquid is suddenly converted into steam, and the water is thrown over into the bulb, which is smashed if it is not sufficiently strong.

Boiled-out water, covered with a layer of oil, may be raised to 120° without boiling, but above this temperature it suddenly begins to boil, and with almost explosive violence.

When a liquid is suspended in another of the same specific gravity, but of higher boiling point, with which it does not mix, it may be raised far beyond its boiling point without the formation of a trace of vapour. Dufour made a number of valuable experiments on this subject ; he used in the case of water a mixture of oil of cloves and linseed oil, and placed in it globules of water, and then gradually heated the oil ; in this way ebullition rarely set in below 110° or 115° ; globules of 10 millimetres' diameter very commonly reached a temperature of 120° or 130°, while very small globules of 1 to 3 millimetres reached the temperature of 175°, a temperature at which the pressure of vapour on a free surface is 8 or 9 atmospheres.

At these high temperatures the contact of a solid body, or the production

of gas bubbles in the liquid, occasioned a sudden vaporisation of the globule, accompanied by a sound like the hissing of a hot iron in water.

Saturated aqueous solutions of copper sulphate, sodium chloride, &c., remain liquid at a temperature far beyond their boiling point, when immersed in melted stearic acid. In like manner, globules of chloroform (which boils at 61°), suspended in a solution of chloride of zinc, could be heated to 97° or 98° without boiling.

It is a disputed question as to what is the temperature of the vapour from boiling saturated saline solutions. It has been stated by Rudberg to be that of pure water boiling under the same pressure. The experiments of Magnus seem to show, however, that this is not the case, but that the vapour of boiling solutions is hotter than that of pure water; and that the temperature rises as the solutions become more concentrated, and therefore boil at higher temperatures. Nevertheless, the vapour was always found somewhat cooler than the mass of the boiling solution, and the difference was greater at high than at low temperatures.

The boiling point of a liquid is usually lowered when it is mixed with a more volatile liquid than itself, but raised when it contains one which is less volatile. Thus a mixture of two parts alcohol and one of water boils at 83° , a mixture of two parts of carbon bisulphide and one part of ether boils at 38° . In some cases the boiling point of a mixture is lower than that of either of its constituents. A mixture of water and bisulphide boils at 43° , the boiling point of the latter being 47° . On this depends the following curious experiment. If water and carbon bisulphide, both at the temperature 45° , are mixed together, the mixture at once begins to boil briskly.

369. Influence of the nature of the vessel on the boiling point.—Gay-Lussac observed that water in a glass vessel required a higher temperature for ebullition than in a metal one. Taking the temperature of boiling water in a copper vessel at 100° , its boiling point in a glass vessel was found to be 101° ; and if the glass vessel had been previously cleaned by means of sulphuric acid and of potash, the temperature would rise to 105° or even to 106° , before ebullition commenced. A piece of metal placed in the bottom of the vessel was always sufficient to lower the temperature to 100° , and at the same time to prevent the violent concussions which accompany the ebullition of saline or acid solutions in glass vessels. Whatever be the boiling point of water, the temperature of its vapour is uninfluenced by the substance of the vessels.

370. Influence of pressure on the boiling point.—We see from the table of pressures (361) that at 100° , the temperature at which water boils under a pressure of 760 millimetres, which is that of the atmosphere, aqueous vapour has a pressure exactly equal to this pressure. This principle is general, and may be thus enunciated: *A liquid boils when the pressure of its vapour is equal to the pressure it supports.* Consequently, as the superincumbent pressure increases or diminishes, the pressure of the vapour, and therefore the temperature necessary for ebullition, must increase or diminish. Hence a liquid has, strictly speaking, an indefinite number of boiling points.

In order to show that the boiling point is lower under diminished pressure, a small dish containing water at 30° is placed under the receiver of an

air-pump, which is then exhausted. The liquid soon begins to boil, the vapour formed being pumped out as rapidly as it is generated.

A paradoxical but very simple experiment also well illustrates the dependence of the boiling point on the pressure. In a glass flask, water is boiled for some time, and when all air has been expelled by the steam, the flask is closed by a cork and inverted, as shown in fig. 352. If the bottom is then cooled by a stream of cold water from a sponge, the water begins to boil again. This arises from the condensation of the steam above the surface of the water, by which a partial vacuum is produced.

It is in consequence of this diminution of pressure that liquids boil on high mountains at lower temperatures. On Mont Blanc, for example, water boils at 84° , and at Quito at 90° .

On the more rapid evaporation of water under feeble pressures is based the use of the air-pump in concentrating those solutions which either cannot bear a high temperature, or which can be more cheaply evaporated in an exhausted space. Howard made a most important and useful application of this principle in the manufacture of sugar. The syrup, in his method, is

enclosed in an air-tight vessel, which is exhausted by a steam-engine. The evaporation consequently goes on at a lower temperature, which secures the syrup from injury. The same plan is adopted in evaporating the juice of certain plants used in preparing medicinal extracts.

On the other hand, boiling is retarded by increasing the pressure; under the pressure of two atmospheres, for example, water only boils at 129.6° .

371. **Franklin's experiment.**—The influence of pressure on boiling may further be illustrated by means of an experiment originally made by Franklin. The apparatus consists of a bulb, *a*, and a tube, *b*, joined by a tube of smaller dimensions (fig. 353).

The tube *b* is drawn out, and the apparatus filled with water, which is then in part boiled away by means of a spirit lamp. When it has been boiled sufficiently long to expel all the air, the tube *b* is sealed. There is then a vacuum in the apparatus, or rather there is a pressure due to the elastic

force of aqueous vapour, which at ordinary temperatures is very small. Consequently, if the bulb, *a*, be placed in the hand, the heat is sufficient

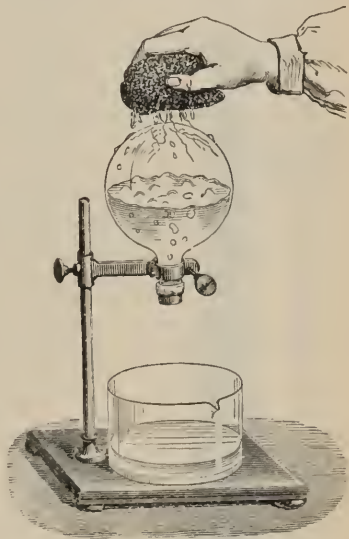

Fig. 352

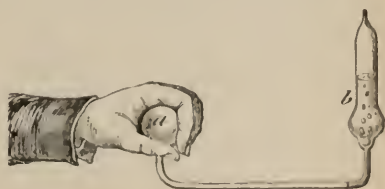

Fig. 353

to produce a pressure which drives the water into the tube, *b*, and causes a brisk ebullition.

372. **Measurement of heights by the boiling point.**—From the connection between the boiling point of water and the pressure, the heights of mountains may be measured by the thermometer instead of by the barometer. Suppose, for example, it is found that water boils on the summit of a mountain at 90° , and at its base at 98° . Since a liquid boils when its vapour pressure is equal to atmospheric pressure, it is only necessary, in order to ascertain the atmospheric pressures at the bottom and top of a mountain, to refer to a table giving corresponding temperatures and vapour pressures. With the help of this table a thermometer gives the same information as a barometer. The barometric pressures being thus known, the height of the mountain may be calculated by the method already given (179). An ascent of about 1080 feet produces a diminution of 1° C. in the boiling point.



Fig. 35*

The instruments used for this purpose are called *thermo-barometers* or *hypsometers*, and were first supplied by Wollaston. They consist essentially of a small metallic vessel for boiling water (fig. 354), fitted with very delicate thermometers, which are only graduated from 80° to 100° ; so that, as each degree occupies a considerable space on the scale, the 10ths, and even the 100ths, of a degree may be estimated, and thus it is possible to determine the height of a place by means of

the boiling point to within about 10 feet.

373. **Formation of vapour in closed tubes.**—We have hitherto considered vapours as being produced in an indefinite space, or where they could expand freely, and it is only under this condition that boiling can take place. In a closed vessel, the vapours produced finding no issue, their pressure and their density increase with the temperature, but that rapid disengagement of vapour which constitutes boiling is impossible. Hence, while the temperature of a liquid in an open vessel can never exceed that of boiling, in a closed vessel it may be much higher. The liquid state has, nevertheless, a limit; for, according to experiments by Cagniard-Latour and others, if either water, alcohol, or ether be placed in strong glass tubes, which are hermetically sealed after the air has been expelled by boiling, and if then these tubes are exposed to a sufficiently high temperature, a moment is reached at which the liquid suddenly disappears, and is converted into vapour. With ether this occurs at 200° ; the vapour then occupies a space less than double its volume in the liquid state, its pressure being then 38 atmospheres.

Alcohol which half fills a tube is converted into vapour at 207° C. If a glass tube about half filled with water, in which some carbonate of soda has been dissolved, to diminish the action of the water on the glass, be heated, it is completely vaporised at about the temperature of melting zinc.

When ethyl chloride is heated in a stout sealed tube, the upper surface ceases to be distinct at 170° , and is replaced by an ill-defined nebulous zone. As the temperature rises this zone increases in width in both directions, becoming at the same time more transparent; after a time the liquid is completely vaporised, and the tube becomes transparent and seemingly empty. On cooling, the phenomena are reproduced in opposite order.

Andrews made a series of observations on the behaviour of condensed gases at different temperatures, by means of an apparatus the principal features of which are represented in fig. 355.

The pure and dry gas is contained in a tube *g*, which is sealed at one end, and the gas is shut in by a thread of mercury. The tube is inserted in a brass end-piece, *E*, which is firmly screwed on a strong copper tube, *R*. At the other end is a similar piece, in which a steel screw works, perfect tightness being ensured by good packing. The tube is full of water, so that by turning this screw the pressure on the enclosed gas can be increased up to 500 atmospheres. In some cases the projecting capillary tube is bent downwards so that it can be placed in a freezing mixture.

Andrews found on raising liquid carbonic acid in such a tube to a temperature of 31° C. that the surface of demarcation between the liquid and the gas became fainter, lost its curvature, and gradually disappeared. The space was then occupied by a homogeneous fluid, which, when the pressure was suddenly diminished, or the temperature slightly lowered, exhibited a peculiar appearance of moving or flickering striæ throughout its whole mass. About 31° no apparent liquefaction of carbonic anhydride, or separation into two distinct forms of matter, could be effected, not even when the pressure of 400 atmospheres was applied.

From similar observations made with other substances it seems that there exists for every liquid a temperature, the *critical point* or *critical temperature*. While below this critical point a sudden transition from gas to liquid is accompanied by a sudden diminution of volume, and liquid and gas are separated by a sharp line of demarcation, above this critical point the change is connected with a gradual diminution of volume, and is quite imperceptible. Hence, ordinary condensation is only possible at a temperature below the critical point, and it is not surprising, therefore, that mere pressure, however great, should have failed to liquefy many of the gases.

These relations are shown in the case of carbonic acid by fig. 356, in which the horizontal lines, the abscissæ, represent volumes, and the vertical



Fig. 355

lines, the ordinates, pressures in atmospheres. Suppose now at the particular temperature 13.1° a given quantity of gas, whose pressure and volume are indicated by the point G on the lowest curve, is subjected to gradually increasing pressure: the volume diminishes until the pressure reaches 48 atmospheres, the gas begins to liquefy, and the continued diminution of its volume completes the liquefaction without change of pressure (this state is represented by the line AB), after which any further increase of pressure only diminishes the volume to much the same extent as any other liquid (96). The behaviour of carbonic acid at 13.1° C. is denoted by the line GABQL. GA gives the relation between the temperature and the pressure of the substance in the gaseous state; AB represents the

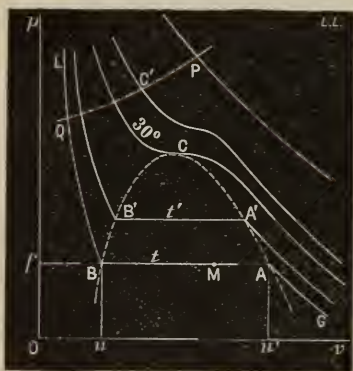

Fig. 356

liquid and gas in equilibrium with each other, while at B the carbonic acid is entirely liquefied, and its volume diminishes only slightly with increased pressure, as shown by the line BQL.

At a higher temperature, 21.5° , the same general results are obtained, except that a pressure of 61 atmospheres (the point A') must be applied before the gas begins to liquefy, and the line A'B' is shorter. On continuing the experiments it is found that at a temperature of 30.9° there is no horizontal part, the lines merge into each other, and at no higher temperature is there a separation into liquid and gas. This is the critical temperature, and the higher the temperature the more nearly does the curve show the behaviour of a perfect gas.

The phenomenon of the critical temperature may be conveniently illustrated by the following arrangement (fig. 357), which is also well adapted for projection on a screen by means of a magic-lantern for lecture purposes. A stout glass tube about 2.5 mm. wide and 40 mm. long contains liquid sulphur dioxide, and is supported, with the drawn-out end downwards, in a test-tube by means of a wire frame. Pure melted paraffin is added to about 10 cm. above the inner tube. The whole arrangement is suspended in a retort-holder and heat applied with a spirit lamp. As the temperature 155° C. (the critical temperature of SO_2) is approached, the liquid evaporates in the ordinary way, and there is a sharp line separating liquid from vapour. At 155° this line vanishes, and at higher temperatures the substance is a homogeneous gas. If the tube is now left to cool, it will be noticed that, as the critical temperature is reached, striæ appear in all parts of the tube, indicating violent commotion, and immediately afterwards liquid and vapour are sharply

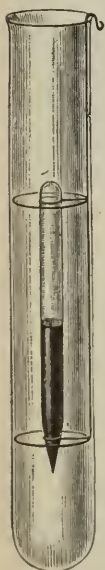

Fig. 357

peratures the substance is a homogeneous gas. If the tube is now left to cool, it will be noticed that, as the critical temperature is reached, striæ appear in all parts of the tube, indicating violent commotion, and immediately afterwards liquid and vapour are sharply

separated from each other. With careful manipulation there is no danger, and the course of the phenomenon is readily seen through the clear paraffin.

The boiling point of a body may be defined as the temperature above which a body passes into the state of gas, not only on the surface but in the body of the liquid; this temperature is therefore different for different pressures, and is accordingly a *relative* magnitude. The *absolute boiling point* is the temperature at which a body is converted into gas, whatever be the pressure; it is identical with the critical temperature. Mendelejeff found that a relation existed between the absolute temperature and the capillarity of liquids. Increase of temperature diminishes the cohesion, and therefore the elevation of a liquid in a capillary tube. The elevation ultimately vanishes, and the temperature at which this takes place is the absolute boiling point. For some it is very low; in the case of air, for instance, it is -158° .

The *critical pressure* is that at which condensation takes place at the critical temperature, and the volume of the saturated vapour at the critical temperature, and under the critical pressure, is called the *critical volume*.

A *vapour* may be defined as being a gas at any temperature below its critical point. Hence a vapour can be converted into a liquid by pressure alone, and can therefore exist at the pressure of its own liquid, while a *gas* requires cooling as well as pressure to convert it into a liquid; that is, to alter its arrangement in such a manner that a liquid can be seen to be separated from a gas by a distinctly bounded surface. Above 31° C. carbonic acid is a gas; below this temperature it is a vapour.

374. **Papin's digester.**—Papin appears to have been the first to investigate the effects of the production of vapour in closed vessels. The apparatus which bears his name consists of a cylindrical iron vessel *M* (fig. 358) provided with a cover, which is firmly fastened down by the screw *B*. In order to close the vessel hermetically, sheet lead is placed between the edges of the cover and the vessel. A cylindrical channel through the cover is closed by a valve to which a rod *u* is attached. This rod presses against a lever *ab*, movable at *a*, and the pressure may be regulated by means of a weight *p* movable on this lever. The lever is so weighted that when the pressure in the interior is equal to six atmospheres, for example, the valve rises and the vapour escapes. The destruction of the apparatus is thus avoided, and this mechanism has hence received the name of *safety-valve*. The digester is filled about two-thirds with water, and is heated on a furnace. The water may thus be raised to a temperature far

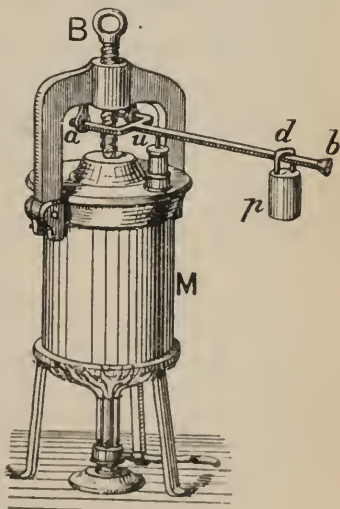

Fig. 358

above 100° , and the pressure of the vapour increased to several atmospheres, according to the weight on the lever.

We have seen that water boils at much lower temperatures on high mountains (370); the temperature of water boiling in open vessels in such localities is not sufficient to soften animal fibre completely and extract the nutriment, and hence Papin's digester is used in the preparation of food. It is also used in extracting gelatine. When bones are digested in this apparatus they are softened so that the gelatine which they contain is dissolved.

375. **Latent heat of vapour.**—As the temperature of a liquid remains constant during boiling, whatever be the source of heat (366), it follows that a considerable quantity of heat becomes absorbed in boiling, the only effect of which is to transform the body from the liquid to the gaseous condition. And, conversely, when a saturated vapour passes into the state of liquid, it gives out a definite amount of heat.

These phenomena were first observed by Black, and he described them by saying that during vaporisation a quantity of sensible heat became latent, and that the latent heat again became free during condensation. The quantity of heat which one pound of a liquid must absorb in passing from the liquid to the gaseous state, and which it gives out in passing from the state of vapour to that of liquid, is spoken of as its *latent heat of vaporisation*.

The analogy of these phenomena to those of fusion will be at once seen; the modes of determining them will be described in the chapter on Calorimetry; but the following results, which have been obtained for the latent heats of evaporation at 0° , may be here given:—

Water	607	Carbon bisulphide	90
Alcohol	236	Turpentine	74
Benzole	109	Chloroform	67
Acetic acid	102	Bromine	49
Ether	94	Iodine	24

The meaning of these numbers is, in the case of water, for instance, that it requires as much heat to convert a pound of water from the state of liquid at 0° C. to that of vapour at the same temperature, as would raise a pound of water through 607 degrees, or 607 pounds of water through one degree; or that the conversion of one pound of vapour of alcohol at 0° into liquid alcohol of the same temperature would heat 236 pounds of water through one degree.

Watt, who investigated the subject, held that the whole quantity of heat necessary to raise a given weight of water from zero to any temperature, and then to evaporate it entirely, or what is called its *total heat of vaporisation*, is a constant quantity. His experiments showed that this quantity is 640. Hence the lower the temperature the greater the latent heat, and, on the other hand, the higher the temperature the less the latent heat. The latent heat of the vapour of water evaporated at 100° would be 540, while at 50° it would be 590. At higher temperatures the latent heat of aqueous vapour would go on diminishing. Water evaporated under a pressure of 15 atmospheres at a temperature of 200° would have a latent

heat of 440, and if it could be evaporated at 640° it would have no latent heat at all. At this temperature it would be in the critical state, being indifferently either liquid or gaseous.

Regnault, who examined this question with great care, found that the total quantity of heat necessary for the evaporation of water increases with the temperature, and is not constant, as Watt had supposed. It is represented by the formula

$$Q = 606.5 + 0.305t,$$

in which Q is the total quantity of heat, and t the temperature of the water during vaporisation, while the numbers are constant quantities. The total quantity of heat necessary to evaporate water at 100° is $606.5 + (0.305 \times 100) = 637$; at 120° it is 643; at 150° it is 651; and at 180° it is 661. Hence the latent heat of vaporisation of water is 537 at 100°, 523 at 120°, 501 at 150°, and 481 at 180° C.

The total heat of the evaporation of ether is expressed by a formula similar to that of water, namely, $Q = 94 + 0.045t$; and that for chloroform $Q = 67 + 0.1375t$.

The heat which is expended simply in evaporating a liquid, and which is spoken of as the latent heat, produces no rise of temperature, and only appears as doing the work of a change of state. One portion of this work is expended in overcoming the cohesion of the particles in the liquid state, and enabling them to assume the gaseous form—this is the *internal work*, and is by much the greater; the other, the *external work*, is expended in overcoming the external pressure on the vapour formed.

Knowing the increase of volume, and the pressure, the external work may be readily calculated; for if the volumes of unit weight of the substance in the state of liquid and of vapour are respectively s and σ , and the pressure p , then the external work is $p(\sigma - s)$, and its heat equivalent $p(\sigma - s)/J$, J being the mechanical equivalent of heat (506). So that, if r is the total heat of vaporisation,

$$r = \rho + p(\sigma - s)/J,$$

in which ρ is the heat spent in internal work. From the values of r and of $p(\sigma - s)/J$, it is easy to deduce that of ρ , and it is found that this value decreases as the temperature increases.

Thus for the temperatures 0°, 50°, 100°, and 150° the values are proportional to 576, 536, 496, and 457 respectively; that is, when water at 0° is converted into vapour, a greater internal work is required to overcome the cohesion, than at 100° for instance.

376. **Cold due to evaporation. Mercury frozen.**—Whatever be the temperature at which a vapour is produced, an absorption of heat always takes place during vaporisation. If, therefore, a liquid evaporates, and does not receive from without a quantity of heat equal to that which is expended in producing the vapour, its temperature sinks, and the cooling is greater in proportion as the evaporation is more rapid.

Leslie succeeded in freezing water by means of its own rapid evaporation. Under the receiver of the air-pump is placed a vessel containing strong sulphuric acid, and above it a thin metal capsule, Λ (fig. 359), containing a

small quantity of water. By exhausting the receiver the water begins to boil (366), and since the vapour is absorbed by the sulphuric acid as fast as it is formed, a rapid evaporation is produced, which quickly effects the freezing of the water.

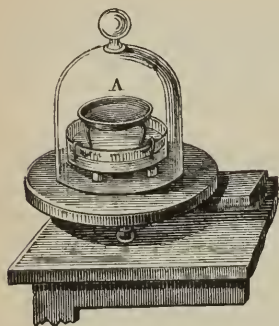

Fig. 359

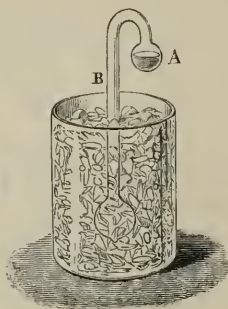

Fig. 360

This experiment is best performed by using, instead of a thin metal dish, a watch-glass coated with lampblack and resting on a cork. The advantage of this is twofold: firstly, the lampblack is a very bad conductor; and,

secondly, it is not moistened by the liquid, which remains in the form of a globule not in contact with the glass. A small porous dish may also advantageously be used.

The same result is obtained by means of Wollaston's *cryophorus* (fig. 360), which consists of a bent glass tube provided with a bulb at each end. The apparatus is prepared by introducing a small quantity of water, which is then boiled so as to expel all air. It is then hermetically sealed, so that on cooling it contains only water and the vapour of water. The water being passed into the bulb A by tilting the apparatus, the other bulb is immersed in a freezing mixture. The vapour in the tube is thus condensed; the water in A rapidly yields more. But this rapid production of vapour requires a large amount of heat, which is abstracted from the water in A, and its temperature is so much reduced that it freezes. The experiment succeeds best when the tube connecting the bulbs is of fairly large diameter.

By using liquids more volatile than water, more particularly liquid sulphurous acid, which boils at -10° , or, still better, methyl chloride, which is now prepared industrially in large quantities, a degree of cold is obtained sufficiently low to freeze mercury. This experiment may be made on a small scale by covering the bulb of a thermometer with cotton wool, and, after having moistened it with the liquid in question, placing it under the receiver of the air-pump. When a vacuum is produced the mercury is quickly frozen.

By passing a current of air, previously cooled, through liquid methyl chloride, temperatures of from -23° to -70° C. may be maintained with great constancy for several hours. Thilorier, by directing a jet of liquid carbonic acid on the bulb of an alcohol thermometer, obtained a temperature of -100° without freezing the alcohol.

By means of the evaporation of carbon bisulphide the formation of ice may be illustrated without the aid of an air-pump. A little water is dropped on a board, and a capsule of thin copper foil, containing carbon bisulphide, is placed on the water. The evaporation of the bisulphide is accelerated by

means of a pair of bellows, and after a few minutes the water freezes round the capsule so that the latter adheres to the wood.

In like manner, if some water is placed in a test-tube, which is then dipped in a beaker containing some ether, and a current of air is blown through the ether by means of a glass tube fitted to the nozzle of a pair of bellows, the rapid evaporation of the ether very soon freezes the water in the tube. Richardson's apparatus for producing local anæsthesia also depends on the cold produced by the evaporation of ether. The lowness of the temperature obtained depends not so much on the magnitude of the latent heat of vaporisation of the liquid as on its volatility and on the rapidity of the conversion. The latent heat of water vapour is more than six times as great as that of ether vapour at 0° (375), but a much lower temperature can be obtained with the latter.

The cold produced by evaporation is used in hot climates to cool water by means of *alcarrazas*. These are porous earthen vessels, through which water percolates, so that on the outside there is a continual evaporation, which is accelerated when the vessels are placed in a current of air. For the same reason wine is cooled by wrapping the bottles in wet cloths and placing them in a draught.

In Harrison's method of making ice artificially, a steam-engine is used to work an air-pump which produces a rapid evaporation of some ether, in which is immersed the vessel containing the water to be frozen. The apparatus is so constructed that the vaporised ether can be condensed and used again.

The cooling effect produced by a wind or draught does not necessarily arise from the wind being cooler, for it may, as shown by the thermometer, be actually warmer, but arises from the rapid evaporation it causes from the surface of the skin. We have the feeling of oppression even at moderate temperatures, when we are in an atmosphere saturated by moisture, in which no evaporation takes place.

377. **Carré's apparatus for freezing water.**—We have already seen that when any liquid is converted into vapour it absorbs a considerable quantity of sensible heat; this furnishes a source of cold which is more abundant the more volatile the liquid, and the greater its heat of vaporisation.

This property of liquids has been utilised by Carré, in freezing water by the distillation of ammonia. The apparatus consists of a cylindrical boiler C (figs. 361, 362), and of a slightly conical vessel A, which is the *freezer*. These two vessels are connected by a tube *m*, and a brace, *n*, binds them firmly. They are made of strong galvanised iron plate, and can resist a pressure of seven atmospheres.

The boiler C, which holds about two gallons, is three parts filled with a strong solution of ammonia. In the upper part of the boiler a tube is fitted in which some oil is placed, and in this a thermometer *l*. The freezer A consists of two concentric envelopes, constructed in such a manner that, its centre being hollow, a metal vessel, G, containing the water to be frozen, can be placed in this space. Hence only the annular space between the sides of the freezer is in communication with the boiler by means of the tube *m*. In the upper part of the freezer there is a small aperture which

can be closed by a metal stopper, and by which the solution of ammonia is introduced.

The formation of ice comprises two distinct operations. In the first, the boiler is placed in a furnace *F*, and the freezer in a bath of cold water of about 12° . The boiler being heated to 130° , the ammoniacal gas dissolved in the water of the boiler is disengaged, and, in virtue of its own pressure, is liquefied in the freezer *A*, along with about a tenth of its weight of water. This distillation of *C* towards *A* lasts about an hour and a quarter, and when it is finished the second operation commences; this consists in placing the boiler in the cold-water bath (fig. 362), and the freezer *A* outside, care being taken to surround it with dry flannel. The vessel *G*, about three-quarters full of water, is placed in the freezer. As the boiler cools, the ammoniacal gas with which it is filled is again dissolved; the pressure thus being

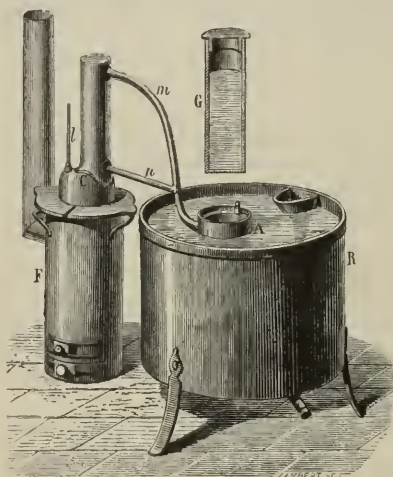

Fig. 361

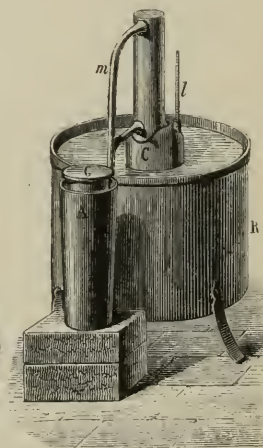

Fig. 362

diminished, the ammonia which has been liquefied in the freezer is converted into the gaseous form, and now distills from *A* towards *C*, to redissolve in the water which has remained in the boiler. During this distillation the ammonia which is gasified absorbs a great quantity of heat, which is withdrawn from the vessel *G* and the water it contains. Hence it is that this water freezes. In order to have better contact between the sides of the vessel *G* and the freezer, alcohol is poured between them. In about an hour and a quarter a perfectly compact cylindrical block of ice can be taken from the vessel *G*.

This apparatus gives about four pounds of ice in an hour, at a price of about a farthing per pound; large continuously working apparatus have, however, been constructed, which produce as much as 800 pounds of ice in an hour.

Carré constructed an ice-making machine which is an industrial appli-

cation of Leslie's experiment (376), and by which considerable quantities of water may be frozen in a short time. It consists of a cylinder, R, about 15 inches long by 4 in diameter, made of an alloy of lead and antimony (fig. 363).

At one end is a funnel E, by which strong sulphuric acid can be introduced; at the other is a smaller vertical cylinder *m*, to which is screwed a dome *d* that supports a series of obstacles intended to prevent any sulphuric acid from spirting into *m* and *b*. There are, moreover, on the receiver a wide tube, *u*, closed by a thick glass disc O, and a long tube *h*, to the top of which is

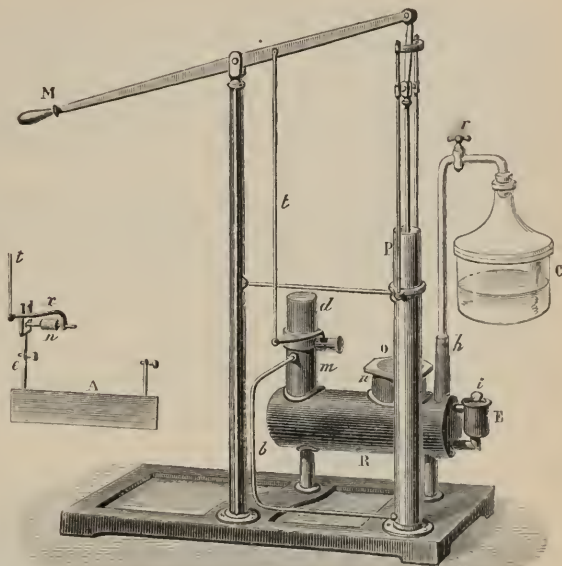

Fig. 363

fitted the bottle C containing water to be frozen. The dome *d*, the disc O, and the stopper *i* of the funnel E are all sealed with wax.

On the side of the receiver is an air-pump P, connected with it by a tube *b*, and worked by a handle M. To this handle is attached a rod *t*, which, by the mechanism represented on the left of the figure, works a stirrer A in the sulphuric acid. A lever *x*, connected with a horizontal axis which traverses a small stuffing-box *n*, transmits its backward and forward motion to the rod *t* and to the stirrer. This and the stuffing-box *n* are fitted in a tubulure on the side of the cylinder *m*.

The smallest size which Carré makes contains 2.5 kilogrammes of sulphuric acid, and the water-bottle about 400 grammes, when it is one-third full. After about 70 strokes of the piston the water begins to boil; the acid being in continued agitation, the vapour is rapidly absorbed by it, and the pump is worked until freezing begins. For this purpose it is merely necessary to give a few strokes every five minutes. The rate of freezing depends on the strength of the acid; when this gets very dilute it requires renewal; but twelve water-bottles can be frozen with the same quantity of acid.

LIQUEFACTION OF VAPOURS AND GASES

378. **Liquefaction of vapours.**—The *liquefaction* or *condensation* of vapours is their passage from the aeriform to the liquid state. Condensation may be due to three causes—cooling, compression, or chemical action. For the first two causes the vapours must be saturated (356), while the latter produces the liquefaction of the most rarefied vapours. Thus, a large number of salts absorb and condense the aqueous vapours in the atmosphere, however small their quantity.

When vapours are condensed, their latent heat becomes free ; that is, it affects the thermometer. This is readily seen when a current of steam at 100° is passed into a vessel of water at the ordinary temperature. The liquid becomes rapidly heated, and soon reaches 100° . The quantity of heat given up in liquefaction is equal to the quantity absorbed in producing the vapour.

379. **Distillation. Stills.**—*Distillation* is an operation by which a volatile liquid may be separated from a substance which it holds in solution,

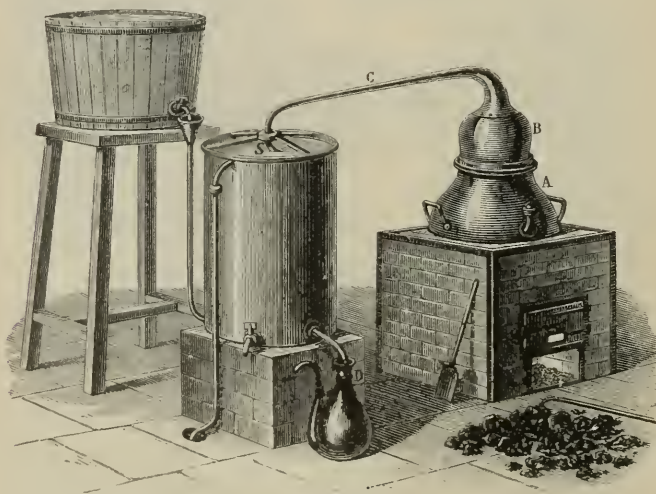

Fig. 364

or by which two liquids of different volatilities may be separated. The operation depends on the transformation of liquids into vapour by the action of heat, and on the condensation of this vapour by cooling.

The apparatus used in distillation is called a *still*. Its form may vary greatly, but it consists essentially of three parts : 1st, the *body*, A (fig. 364), a copper vessel containing the liquid, the lower part of which fits in the furnace ; 2nd, the *head*, B, which fits on the body, and from which a lateral tube, C, leads to, 3rd, the *worm*, S, a long spiral tin or copper tube placed

in a cistern kept constantly full of cold water. The object of the worm is to condense the vapour by exposing a greater extent of cold surface.

To free ordinary water from the many impurities which it contains, the water is placed in a still and heated. The vapours disengaged are condensed in the worm, and the distilled water arising from the condensation is collected in the receiver D. The vapours in condensing rapidly heat the water in the cistern, which must therefore be constantly renewed. For this purpose a continual supply of cold water passes into the bottom of the cistern, while the lighter heated water rises to the surface and escapes by a tube in the top of the cistern.

380. **Liebig's condenser.**—In distilling smaller quantities of liquids, the apparatus known as *Liebig's condenser* is extremely useful. It consists of a glass tube, *tt* (fig. 365), about thirty inches long, fitted in a copper or tin

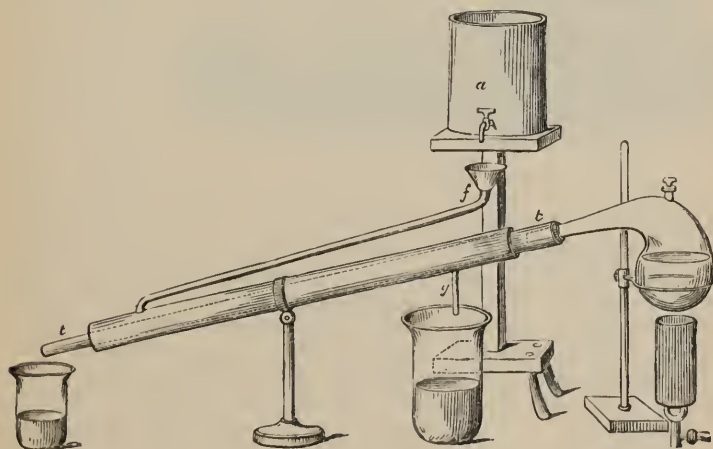

Fig. 365

tube by means of perforated corks. A constant supply of cold water from the vessel *a* passes into the space between the two tubes, being conveyed to the lower part of the condenser by a funnel and tube *f*, flowing out from the upper part of the tube *g*. The liquid to be distilled is contained in a retort, the neck of which is placed in the tube; the condensed liquid drops quite cold into a vessel placed to receive it at the other end of the condensing tube.

381. **Apparatus for determining the alcoholic value of wines.**—One of the forms of this apparatus consists of a glass flask resting on a tripod, and heated by a spirit lamp (fig. 366). By means of an india-rubber tube this is connected with a worm placed in a copper vessel filled with cold water, below which is a test-glass for collecting the distillate. On this are three divisions, one, *a*, which measures the quantity of wine taken; the two others indicating one-half and one-third of this volume.

The test-glass is filled with the wine up to *a*, and this wine is then

poured into the flask; the latter having been connected with the worm, the distillation is commenced. The liquid which distils over is a mixture

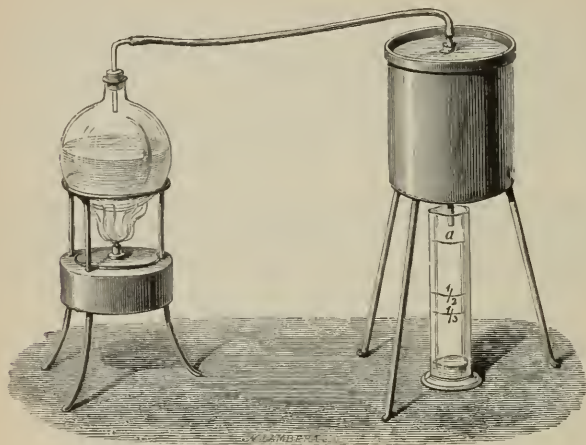

Fig. 366

of alcohol and water; for ordinary wines, such as clarets and hocks, about one-third is distilled over, and for wines richer in spirit, such as sheries and ports, one-half must be distilled; experiment has shown that in these circumstances practically all the alcohol passes over in the distillate.

The measure is then filled up with distilled water to *a*; this gives the mixture of alcohol and water of the same volume as the wine taken, free from all solid matters, such as sugar, colouring matter, and acid, but containing all the alcohol. The specific gravity of this distillate is then taken by means of an alcoholometer (126), and the number thus obtained corresponds to a certain strength of alcohol as indicated by the tables.

382. **Safety-tube.**—In preparing gases and collecting them over mercury or water, it occasionally happens that these liquids rush back into the generating vessel, and destroy the operation. This arises from an excess of atmospheric pressure over the elastic force in the vessel. If a gas—sulphurous acid for example—is generated in the flask *m* (fig. 367), and is passed into water in the vessel *A*, as long as the gas is given off freely, its elastic force exceeds the atmospheric pressure, and the weight of the column of water, *on*, so that the water in the vessel cannot rise in the tube, and absorption is impossible. But if the pressure decreases, either



Fig. 367

through the flask becoming cooled or the gas being disengaged too slowly, the external pressure prevails, and when it exceeds the internal pressure by more than the weight of the column of water *ca*, the water rises into the flask, and the operation is spoiled. This accident is prevented by means of *safety-tubes*.

These are tubes which prevent absorption by allowing the air to enter in proportion as the internal pressure decreases. The simplest is a tube *C* (fig. 368), passing through the cork which closes the flask *M*, in which the

gas is generated, and dipping in the liquid. When the pressure of the gas diminishes in M, the atmospheric pressure on the water in the bath E causes it to rise to a certain height in the tube DA; but this pressure, acting also on the liquid in the tube C, depresses it to the same depth, assuming that the liquid has the same density as the water in E. Now, as this depth is less than the height DH, air enters by the aperture, before the water in the bath can rise to A, and no absorption takes place.

383. **Liquefaction of gases.**—We have already seen that a saturated vapour, the temperature of which is constant, is liquefied by decreasing the volume, and that, the volume remaining constant, it is brought into the liquid state by diminishing the temperature.

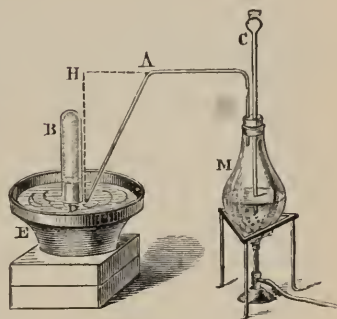

Fig. 368

Unsaturated vapours behave in all respects like gases. For the gaseous form is accidental, and is not inherent in the nature of the substance. At ordinary temperatures sulphurous anhydride is a vapour, while in countries near the Poles it is a liquid; in temperate climates ether is a liquid, at a tropical heat it is a vapour. And just as unsaturated vapours may be brought to the state of saturation, and then liquefied, by suitably diminishing the temperature or increasing the pressure, so by the same means gases may be liquefied. But as they are mostly very far removed from this state of saturation, great cold and pressure are required. Some of them may indeed be liquefied either by cold or by pressure; for the majority, however, both agencies must be simultaneously employed. Recent researches have shown that the distinction *permanent gas* no longer exists, now that all the gases which were called permanent have been liquefied.

We have seen that there is for each gas a *critical* temperature (373), such that no pressure, however great, can liquefy a gas which is above this temperature. If a gas is below this point, then the nearer it is to it the greater is the pressure required; conversely, if the temperature is very low, the pressure required to liquefy it may be low too.



Fig. 369

Faraday was the first to liquefy some of the gases. His method consists in enclosing in a bent glass tube (fig. 369) substances by whose chemical action the gas to be liquefied is produced, and then sealing the shorter leg. In proportion as the gas is disengaged its pressure increases, and it ultimately liquefies and collects in the shorter leg, more especially if its condensation is assisted by placing the shorter leg in a freezing mixture. A small manometer may be placed in the apparatus to indicate the pressure.

Cyanogen gas is readily liquefied by heating cyanide of mercury in a

bent tube of this description ; other gases have been condensed by taking advantage of special reactions, the consideration of which belongs rather to chemistry than to physics. For example, silver chloride absorbs about 200 times its volume of ammonia ; when the compound thus formed is placed in the long leg of a bent tube and gently heated, while the shorter leg is immersed in a freezing mixture, a quantity of liquid ammonia speedily collects in the shorter leg.

384. **Apparatus to liquefy and solidify gases.**—Thilorier first constructed an apparatus by which considerable quantities of carbonic acid could be liquefied. Its principle is the same as that used by Faraday in working with glass tubes ; the gas is generated in an iron cylinder, and passes through a metal tube into another similar cylinder, where it condenses. The use of this apparatus is not free from danger ; many accidents have already happened with it, and it has been superseded by an apparatus constructed by Natterer, of Vienna, which is both convenient and safe.

A perspective view of the apparatus, as modified by Bianchi, is represented in fig. 371, and a section on a larger scale in fig. 370. It consists of a wrought-iron reservoir A, of something less than a quart capacity, which can resist a pressure of more than 600 atmospheres. A small force-pump is screwed on the lower part of this reservoir. The piston rod *t* is moved by the crank-rod E, which is worked by the handle M. As the compression of the gas and the friction of the piston produce a considerable disengagement of heat, the reservoir A is surrounded by a copper vessel, in which ice or a freezing mixture is placed. The water arising from the melting of the ice passes by a tube *m* into a cylindrical copper case C, which surrounds the force-pump, whence it escapes through the tube *n* and the stopcock *o*. The whole arrangement rests on an iron frame, PQ.

The gas to be liquefied is previously collected in airtight bags R, whence it passes into a bottle V, containing some suitable drying substance ; it then passes into the condensing pump through the vulcanised india-rubber tube H. After the apparatus has been worked for some time the reservoir A can be unscrewed from the pump without any escape of the liquid, for it is closed below by a valve S (fig. 370). In order to collect some of the liquid gas, the reservoir is inverted, and on turning the stopcock *r* the liquid escapes by a small tubulure *x*. The specific gravity of liquid CO₂ is 0.88.

When carbonic acid has been liquefied and is allowed to escape into the air, a portion only of the liquid volatilises ; in consequence of the heat absorbed by this evaporation, the rest is so much cooled as to solidify in white flakes like snow or anhydrous phosphoric acid. This may be collected by placing a stout woollen bag like a tobacco pouch over a pipe attached to the tube *x* ; if the porous mass is compressed or hammered in stout wooden cylinders, sticks of solid carbonic acid are obtained, very like chalk in appearance. Its specific gravity is 1.2.

Solid carbonic acid evaporates very slowly. By means of an alcohol thermometer its temperature has been found to be about -90° C. A small quantity placed on the hand does not produce the sensation of such great cold as might be expected. This arises from the imperfect contact. But if the solid be mixed with ether the cold produced is so intense that when a little is placed on the skin all the effects of a severe burn are produced. A

mixture of these two substances solidifies four times its weight of mercury in a few minutes. When a tube containing liquid carbonic acid is placed in this mixture, the liquid becomes solid and looks like a transparent piece of ice.

The most remarkable liquefaction obtained by this apparatus is that of nitrous oxide. The gas once liquefied only evaporates slowly, and produces a temperature of -88° C. Mercury placed in it in small quantities instantly

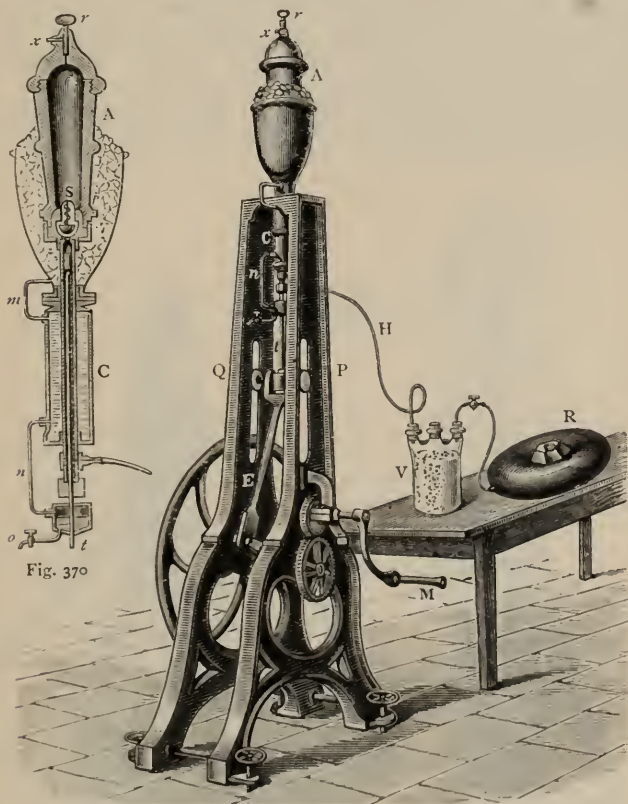

Fig. 370

Fig. 371

solidifies. The same is the case with water; it must be added drop by drop, otherwise, its latent heat being much greater than that of mercury, the heat given up by the water in solidifying would be sufficient to cause an explosion of the nitrous oxide.

Nitrous oxide is readily decomposed by heat, and has the property of supporting the combustion of bodies with almost as much brilliancy as oxygen; and even at low temperatures it preserves this property. When a

piece of incandescent charcoal is thrown on liquid nitrous oxide, it continues to burn with a brilliant light.

The cold produced by the evaporation of ether (376) has been used by Loir and Drion in the liquefaction of gases on a small scale. By passing a current of air from a blowpipe bellows through several tubes into a few ounces of ether, a temperature of -34° C. can be reached in five or six minutes, and may be kept up for fifteen or twenty minutes. By evaporating liquid sulphurous acid in the same manner a great degree of cold, -50° C., is obtained. At this temperature ammonia may be liquefied. By rapidly evaporating liquid ammonia under the air-pump in the presence of sulphuric acid, a temperature of -87° is attained, which is found sufficient to liquefy carbonic acid under the ordinary pressure of the atmosphere.

385. **Caillietet's researches.**—Caillietet and Pictet, working independently, but simultaneously, have effaced the old distinction between permanent and

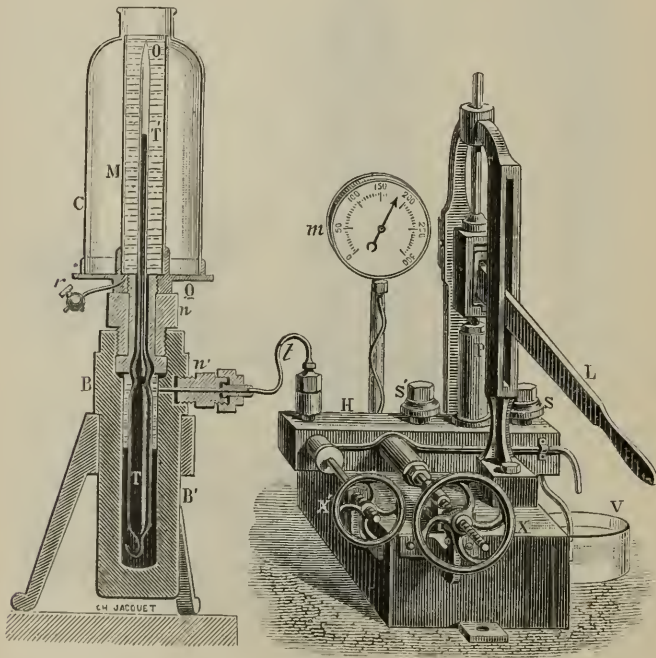

Fig. 372

non-permanent gases, by effecting the liquefaction of oxygen, and other gases which it was supposed could not be condensed. This has been accomplished by means of powerful material appliances directed with great skill and ingenuity. The critical temperature of these gases is mostly below -100° , while their critical pressure is somewhat less than

that of carbonic acid, excepting in the case of hydrogen, which is over 100 atmospheres.

The essential parts of Cailletet's apparatus are represented in fig. 372. BB' is a strong wrought-iron bath containing mercury; in this is placed the tube TO, the upper part of which is capillary and contains the gas to be liquefied. This tube is supported by a screw *n*, in which it is fixed by marine glue. In the side of BB' is a second screw, through which passes a tube *z*, giving passage to the water forced by the pump. The valves of this, one for suction and one for compression, are placed under the screws S and S'. A screw plunger worked by the wheel X serves to force the pressure, while by a stopcock worked by a wheel X' the compressed gas can be suddenly allowed to expand. A manometer *m* fixed on the case indicates the pressure.

For introducing the gas the tube TO is placed horizontally, the capillary end being still open, and pure well-dried gas is admitted at the other end (fig. 373) by an india-rubber tube. When all air is expelled, the end O is



Fig. 373

sealed, the tube held vertically so that a drop of mercury *a* previously introduced closes the tube. It is then placed in the bath BB', *n* being firmly screwed. On this is fixed the plate Q, to which is attached a cylinder M, which can be filled with water or a freezing mixture. This vessel is surrounded by a safety bell-jar, C.

By working the force pump a pressure of 400 atmospheres can be produced, which can be increased to 2500 atmospheres by means of the screw piston. When a suitable pressure has been applied, if we wait until the heat due to the compression has disappeared, and then suddenly open the screw worked by the wheel X, thereby reducing the pressure to one atmosphere, the cold produced by the sudden expansion of the gas in the tube OT' is so great as to liquefy a portion of it, as is shown by the production of a mist.

This observation was first made with nitric oxide, but similar results have been obtained with marsh gas, carbonic oxide, and oxygen.

386. **Pictet's method.**—The principle of Pictet's method is that of liberating the gas under great pressure, combined with the application of a very low temperature. The essential parts of the apparatus are the following:—Two double-acting pumps, A and B (fig. 374), are so coupled together that they cause the evaporation of liquid sulphurous acid contained in the annular receiver C. By the action of the pumps the gas thus evaporated is forced into the receiver D, where it is cooled by a current of water, and again liquefied under a pressure of three atmospheres. Thence it passes again by the narrow tube *d* to the receiver C, to replace that which is evaporated.

In this way the temperature of the liquid sulphurous acid is reduced to -65° . Its function is to produce a sufficient quantity of liquid carbonic acid,

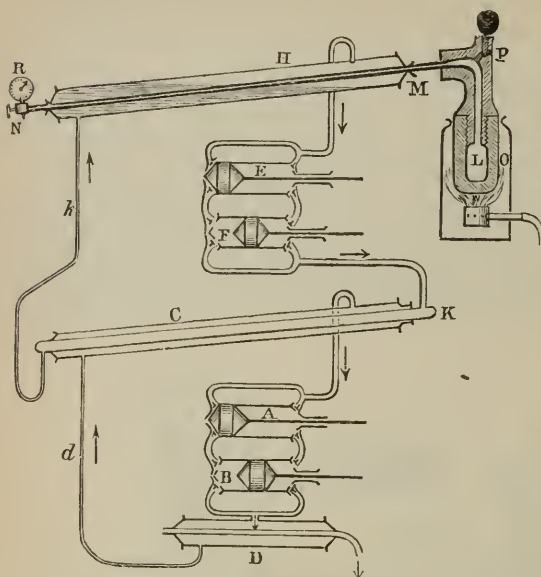

Fig. 374

which is then submitted to a perfectly analogous process of rarefaction and condensation.

This is effected by means of two similar pumps, E and F. The carbonic acid gas, perfectly pure and dry, is drawn from a reservoir not represented in the figure, and is forced into the condenser K, which is cooled by the liquid sulphurous acid to a temperature of -65° , and is there liquefied.

H is a tube of stout copper connected with the condenser K by a narrow tube *h*.

When a sufficient quantity of carbonic acid has been liquefied, the connection with the gasholder is cut off, and by working the pumps E and F a vacuum is created over the liquid carbonic acid in H, which produces so great a cold as to solidify it.

L is a stout wrought-iron retort capable of standing a pressure of 1500 atmospheres. In it are placed the substances by whose chemical actions the gas is produced: potassium chlorate in the case of oxygen. The retort is connected with a strong copper tube in which the actual condensation is effected. This tube, the pressure in which is indicated by a specially constructed manometer R, is closed by a stopcock N.

When the four pumps are set in action, for which a steam-engine of 15 horse-power is required, heat is applied to the retort. Oxygen is liberated in a calculated quantity, the temperature of the retort being about 485° C. Towards the close of the decomposition the manometer indicates a pressure of 500 atmospheres, and then sinks to 320. This diminution is due to the condensation of gas, and at this stage the tube contains liquefied oxygen. If the cock N is opened, the liquid issues with violence, having the appearance of a dazzling white pencil. This lasts three or four seconds. On closing the stopcock the pressure, which had diminished to 400 atmospheres, now rises, and again becomes stationary, proving that the gas is once more being condensed.

The phenomena presented by the jet of oxygen when viewed by the electric light showed that the light it emits was partially polarised, indicating a probable transient crystallisation of the liquid.

The following table exhibits some of the physical properties of substances, gaseous at ordinary temperatures, when reduced to very low temperatures.

Name	Critical temperature	Boiling point at atmospheric pressure	Freezing point	Density of the liquid at the boiling point	Colour of liquid
Hydrogen . . .	-235	-252·5	-258 ^o to -260	·07	Colourless
Fluorine . . .	—	-187	—	1·14	Pale yellow
Nitrogen . . .	-146·0	-194	-214·0	1·10	Colourless
Carbonic oxide . . .	-139·5	-190	-207·0	(?)	"
Oxygen . . .	-118·8	-182·5	—	1·13	Bluish
Argon . . .	-117·4	-186·1	-190	1·212	Colourless
Nitric oxide . . .	-93·5	-154	-167·0	—	"
Methane . . .	-81·8	-162	-186	0·415	"

387. **Later researches.**—Wroblewski and Olszewski made use of the apparatus represented in fig. 375. The gas to be liquefied is contained in the tube *qr*, and is compressed by means of a sort of Cailletet pump coupled up with *b*. Liquid ethylene is contained in the reservoir *x*, which is surrounded by a freezing mixture of ice and salt; it passes thence through the tube *b'*, which is surrounded by a paste of solid carbonic acid and ether, and then reaches *s*, cooled down to a temperature of -100° .

By means of an air-pump to which is connected the lead tube *v* this cooled liquid can be caused to evaporate under a pressure of 25 mm., so that the temperature as indicated by the hydrogen thermometer *t* is -136° . The vessel in which this is effected contains calcium chloride *y*, the object of which is to prevent any deposition of dew on the tube.

At a temperature of -136° oxygen at once liquefies under a pressure of 20 atmospheres. By still further reducing the pressure so that ethylene evaporates at a pressure of 1 mm. the temperature sinks to -152° C., and now nitrogen and carbonic oxide can be directly condensed.

If again the space above these liquids is rarefied, carbonic oxide becomes solid at -190° , and nitrogen at -203° .

Dewar has carried out extensive researches on the liquefaction of gases, and has liquefied and even solidified air. The methods adopted do not differ in principle from

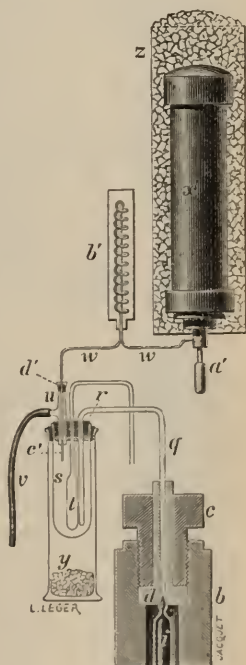

Fig. 375

those which have been mentioned ; the cold is produced by the evaporation of liquid ethylene.

Ladenburg and Krügel (1900) determined the boiling and freezing points of a number of substances. They employed a thermo-electric couple, and compared its scale with a hydrogen thermometer at three temperatures, viz. the boiling point of liquid air, -191.25° ; of ethylene, -102.9° ; and the sublimation point of solid carbon dioxide, -77.5° . The following table gives some of their results:—

Substance	Boiling point	Melting point
Oxygen	-182.2 at 745 mm.	0
Nitrous oxide	-142.8 „ 757 „	-150.5
Ammonia	—	-75.5
Hydrochloric acid	-83.1 at 755.4 „	-111.3
Hydrobromic acid	-68.1 „ 755.4 „	-86.13
Sulphuretted hydrogen	-60.4 „ 755 „	-82.9
Methane	-162 „ 751 „	—
Ethane	-84.1 „ 749 „	-172.1
Acetylene	-82.4 (sublimation point)	Sublimes
Methyl alcohol	—	-93.9
Ethyl alcohol	—	-111.8
Ether	—	-113.1

By a device of Sir J. Dewar it is possible to keep liquefied gases in open vessels at atmospheric pressure with very little evaporation. The glass vessel in which the liquefied gas is contained is surrounded by another, the space between the two being highly exhausted. Thus no heat can leave the inner vessel by conduction or convection ; and when the inside of the inner vessel is silvered, heat radiated from the outside is practically excluded.

Fig. 376 illustrates an arrangement of two such vessels, one within the other, forming a double jacketed system. C is liquid air contained in the inner vessel, which is surrounded by its vacuum jacket. This vessel is closed by a stopper through which passes a tube, A, which may be connected to an air-pump. The outer vessel also contains liquefied air ; it is protected by another vacuum jacket, G, and may be connected to an air-pump by the tube B. In this arrangement no evaporation takes place from A, for all the heat which it might receive from the outside by conduction, convection, or radiation is absorbed by the liquid in the outer vessel. By connecting B with an air-pump so as to reduce the pressure to about 10 mm., and simultaneously connecting A with an air-pump, the liquid air may be so reduced in temperature that it solidifies to a jelly-like mass.

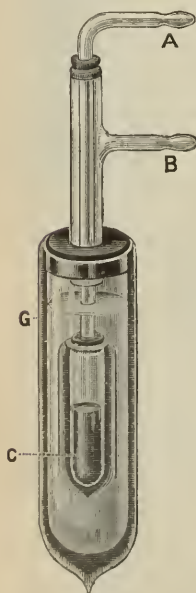

Fig. 376

These experiments have made it possible to examine physical properties of various substances at temperatures which approach absolute zero. It is impossible here to give an account of the results obtained, but some of the most important will be mentioned in their places. One interesting experiment may be mentioned. If a barometer is prepared in the usual way, and a sponge dipped in liquid air is applied to a portion of the outer surface of the Torricellian vacuum space, a mirror of metallic mercury is immediately deposited on the inside.

Linde and Hampson have constructed apparatus for the liquefaction of gases, which works continuously and depends essentially on the cooling produced when a gas expands; it may be looked upon as the reverse of a *regenerative furnace*. The main features of this apparatus are represented in fig. 377.

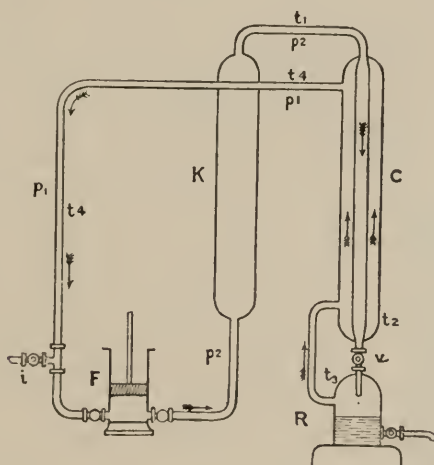

Fig. 377

Consider, in the first case, a single round of operations. Air supplied through the intake *i*, at the pressure p_1 and temperature t_1 , is brought by the compressor *F* to the pressure p_2 , say of 50 atmospheres, thereby becoming heated, but by passing through the cooler *K* is restored to the temperature t_4 ; from this it passes through the inner tube of *C*, which is the characteristic feature of the apparatus; meeting there a current of cooled gas proceeding in the opposite direction through the annular space of *C*, its temperature is lowered to t_2 .

If the throttle valve *v* is opened for a moment the gas suddenly expands, its pressure is reduced to p_1 , and its temperature falls to t_3 . With this latter temperature it passes through the annular space of *C*, and so back to the compressor *F*, cooling, as already stated, the current passing in the opposite direction through the inner tube and itself becoming raised to the temperature t_4 .

The gas thus reduced to this latter temperature, and at the original pressure p_1 , again goes through the same round of operations, again experiencing a further reduction of temperature until liquefaction sets in. The operations are, in fact, continuous, and with a large apparatus of this kind several litres of liquid air have been prepared in an hour.

LIQUEFACTION OF HYDROGEN.—The principal feature of Hampson's or Linde's apparatus is that the gas at high pressure suddenly expands and is thereby cooled; the expanded and cooled gas circulates round the tube containing the compressed gas, and cools it, and thus expansion at the nozzle takes place at a temperature which falls lower and lower, until finally it reaches that at which the gas liquefies. It was by making use of this principle of cooling by free expansion, combined with the cooling effect due to liquid air boiling at reduced pressure, that Dewar (1900) succeeded in liquefying hydrogen. The difficulty arises from the extremely low critical temperature of hydrogen, viz. -235° C. Liquid air boils at about -191° under atmospheric pressure, and at -210° if the pressure is sufficiently reduced. The process then for liquefying hydrogen is as follows:—The gas at 200 atmospheres pressure is cooled to about -205° by air boiling into a vacuum, and is then further cooled by free expansion to, say, -215° C., and returns to the gasholder. But before doing so it begins the process of intensification by passing over the coil containing the compressed hydrogen, and giving up to this the 10 degrees of additional cooling which it had gained by expansion. Thus the high-pressure gas which succeeds it reaches the nozzle at -215° C., and expanding from a lower temperature gains by free expansion a greater amount of cooling, say 15° , so that it now passes away over the coil at -230° C., and cools to this temperature the compressed gas by which it is succeeded. This intensification proceeds until the cooling reaches the boiling point of hydrogen at the pressure of the gasholder, which is practically atmospheric. Liquid hydrogen then collects in the vessel below the nozzle. The temperature of liquid hydrogen at atmospheric pressure was estimated by Dewar at -252.5° C., or 28.5° absolute. Dewar also boiled liquid hydrogen at low pressure, and found it to be, like nitrogen and carbonic acid, one of the substances which readily freeze themselves by evaporation. In the solid hydrogen thus obtained he reached the lowest temperature known, which he estimated at 13° to 15° absolute—temperatures confirmed by his subsequent observations by helium thermometer.

One of the results of liquefying hydrogen has been to show that helium is a still more volatile gas. It is possible, therefore, to reach a lower temperature than that of liquid—probably even than that of solid—hydrogen, by applying to helium the same process of free expansion and continuous cooling which has been successful in the case of hydrogen. Helium has been reduced to 10° A. without freezing (Dewar).

With regard to the very low temperatures here dealt with it may be stated that between 1100° C. and -200° C. the platinum resistance thermometer is available. Below -200° the hydrogen thermometer may be used, for Dewar has shown that *at low pressures* hydrogen may be used as a thermometric substance at temperatures as low as its own liquefying or freezing point. He proved this by means of a helium thermometer, just as he had

proved by the aid of a hydrogen thermometer that air or nitrogen may be used as a thermometric substance for temperatures down to their liquefying points.

MIXTURE OF GASES AND VAPOURS

388. **Laws of the mixture of gases and vapours.**—Every mixture of a gas and a vapour obeys the two following laws :—

I. *The pressure, and, consequently, the quantity, of vapour which saturates a given space are the same for the same temperature, whether this space contains a gas or is a vacuum.*

II. *The pressure of the mixture of a gas and a vapour is equal to the sum of the pressures which each would exert if it occupied the same space alone.*

These are known as *Dalton's laws*, from their discoverer, and are demonstrated by the following apparatus, which was invented by Gay-Lussac :—It consists of a glass tube A (fig. 378), to which two stopcocks, *b* and *d*, are cemented. A tube B of smaller diameter is connected with the tube A just above the stopcock *d*. A scale between the two tubes serves to measure the heights of the mercurial columns in these tubes.

The tube A is filled with mercury, and the stopcocks *b* and *d* are closed. A glass globe M, filled with dry air or any other gas, is screwed on by means of a stopcock in the place of the funnel C. All three stopcocks are then opened, and a little mercury is allowed to escape, which is replaced by the dry air of the globe. The stopcocks are then closed, and as the air in the tube expands on leaving the globe, the pressure on it is less than that of the atmosphere. Mercury is accordingly poured into the tube B until it is at the same level in both tubes. The globe is then removed, and replaced by the funnel C, provided with a stopcock *a* of a peculiar construction. It is not perforated, but has a small cavity, as represented in *n*, on the left of the figure. Some of the liquid to be vaporised is poured into C, and the height of the mercury *k* having been noted, the stopcock *b* is opened and *a* turned so that its cavity becomes filled with liquid; being again turned, the liquid enters the space A and vaporises. The liquid is allowed to fall drop by drop until the air in the tube is saturated, which is the case when the level *k* of the mercury ceases to sink (356).

As the pressure of the vapour produced in the space A is added to that of the air already present, the total volume of gas is increased. It may easily be restored to its original volume by pouring mercury into B. When

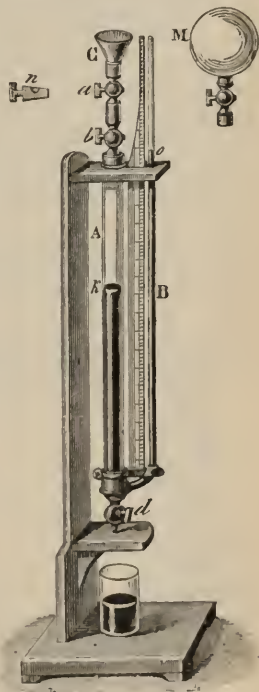

Fig. 378

the mercury in the large tube has been raised to the level k , there is a difference $B\theta$ in the level of the mercury in the two tubes which obviously represents the pressure of the vapour; for as the air has resumed its original volume, its pressure has not changed. Now, if a few drops of the same liquid are passed into the vacuum of a barometer tube, a depression exactly equal to $B\theta$ is produced, which proves that, for the same temperature, the pressure of a saturated vapour is the same in a gas as in a vacuum; from which it is concluded that at the same temperature the quantity of vapour is also the same.

The second law is likewise proved by this experiment, for, when the mercury has regained its level, the mixture supports the atmospheric pressure on the top of the column B, in addition to that due to the weight of the column of mercury $B\theta$. But of these two pressures, one represents that of the dry air, and the other that of the vapour. The second law is, moreover, a necessary consequence of the first.

Experiments can only be made with this apparatus at ordinary temperatures; but Regnault, by means of an apparatus which can be used at different temperatures, investigated the pressures of the vapours of water, ether, bisulphide of carbon, and benzole, both separately and when mixed with air. He found that the pressure when air is present is less than it is in a vacuum, but the differences are so small as not to invalidate Dalton's law. Regnault was even inclined to consider this law as theoretically true, attributing the differences which he observed to the hygroscopic properties of the sides of the tubes.

389. **Problems on mixtures of gases and vapours.**—i. A volume of dry air V , at the pressure H , being given, what will be its volume V' , when it is saturated with vapour, the temperature and the pressure remaining the same?

If F is the pressure of the vapour which saturates the air, the latter, in the mixture, only supports a pressure equal to $H - F$. But by Boyle's law the volumes V and V' are inversely as their pressures; consequently

$$\frac{V'}{V} = \frac{H}{H - F}, \text{ whence } V' = \frac{VH}{H - F}.$$

ii. Let V be a given volume of saturated air at the pressure H and the temperature t ; what will be its volume V' , also saturated, at the pressure H' and the temperature t' ?

If f is the maximum pressure of aqueous vapour at t° , and f' its maximum pressure at t'° , the air alone in each of the mixtures V and V' will be respectively under the pressures $H - f$ and $H' - f'$; consequently, from the formula $pv / (1 + at) = \text{constant}$, we have

$$\frac{(H - f)V}{1 + at} = \frac{(H' - f')V'}{1 + at'}, \text{ whence } V' \text{ is determined.}$$

iii. What is the weight P of a volume of air V saturated with aqueous vapour at the temperature t and pressure H ?

If F is the maximum pressure of the vapour at t° , the pressure of the air alone will be $H - F$, and the problem reduces itself to finding: 1st, the weight of a volume V of dry air at t and under the pressure $H - F$; and

2nd, the weight of the same volume of saturated vapour at t° under the pressure F .

The volume of dry air at standard temperature and pressure is

$$\frac{V}{1+at} \cdot \frac{H-F}{760}, \text{ and its weight } \frac{Vd}{1+at} \cdot \frac{H-F}{760},$$

where d = density of air at 0° , = .31 grain per cubic inch, or = .001293 gramme per cubic centimetre.

Since the density of aqueous vapour is $\frac{5}{8}$ (strictly .622) that of air at the same temperature and pressure, the weight of the aqueous vapour occupying the volume V is

$$\frac{5}{8} \cdot \frac{Vd}{1+at} \cdot \frac{F}{760}.$$

Hence weight P of the moist air

$$= \frac{Vd}{1+at} \cdot \frac{H-F}{760} + \frac{Vd}{1+at} \cdot \frac{5F}{8 \cdot 760} = \frac{Vd}{1+at} \cdot \frac{H-\frac{3}{8}F}{760}.$$

SPHEROIDAL STATE

390. **Leidenfrost's phenomena. Boutigny's experiments.**—When liquids are thrown upon incandescent metal surfaces they present remarkable phenomena, which were first observed by Leidenfrost a century ago, and have been named after their discoverer. They have since then been studied by other physicists, and more especially by Boutigny.

Fig. 379 represents an interesting method of illustrating this. F is a small copper flask which is heated to dull redness over a spirit lamp, and a small quantity of boiling hot water is carefully introduced; a cork C with a small tube passing through it having been fitted, the lamp is removed, and in a short time steam is formed rapidly with such explosive violence as to drive out the cork. The small tube is to allow the escape of vapour which forms slowly.

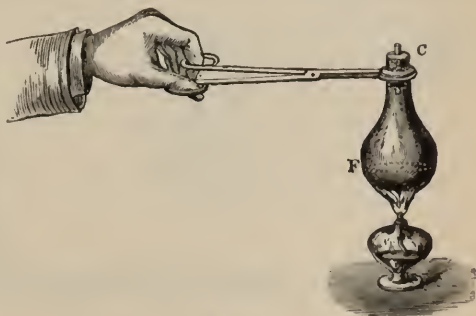

Fig. 379

When a tolerably thick silver or platinum dish is heated to redness, and a little water, previously warmed, is dropped into the dish by means of a pipette, the liquid does not spread itself out on the dish, and does not moisten it, as it would at the ordinary temperature, but assumes the form of a flattened globule, which fact Boutigny expressed by saying that it has passed into the *spheroidal state*. It rotates rapidly round on the bottom of the dish, taking sometimes the form of a star, and not only does it not boil, but its evaporation is only about one-fiftieth as rapid as if it boiled. As the

dish cools, a moment arrives when it is not hot enough to keep the water in the spheroidal state; it is accordingly moistened by the liquid and a violent ebullition suddenly ensues.

All volatile liquids can assume the spheroidal condition; the lowest temperature at which it can be produced varies with each liquid, and is more elevated the higher the boiling point of the liquid. For water, the dish must have at least a temperature of 200° ; for alcohol 134° ; and for ether 61° .

The temperature of a liquid in the spheroidal state is always below its boiling point. This temperature has been measured by Boutigny by means of a very delicate thermometer; but his method is not free from objections, and it is probable that the temperatures he obtained were too high. He found that of water to be 95° ; alcohol, 75° ; ether, 34° ; and liquid sulphurous acid, -11° . But the temperature of the vapour which is disengaged appears to be as high as that of the vessel itself.

This property of liquids in the spheroidal state of remaining below their boiling point was applied by Boutigny in a remarkable experiment, that of freezing water in a red-hot crucible. He heated a platinum dish to bright redness, and placed a small quantity of liquid sulphurous acid in it. It immediately assumed the spheroidal condition, and its evaporation was remarkably slow. Its temperature, as has been stated, was about -11° , and when a small quantity of water was added, it immediately solidified, and a small piece of ice could be thrown out of the red-hot crucible. In a similar manner Faraday, by means of a mixture of solid carbonic acid and ether, succeeded in freezing mercury in a red-hot crucible.

In the spheroidal state the liquid is not in contact with the vessel. Boutigny proved this by heating a silver plate placed in a horizontal position

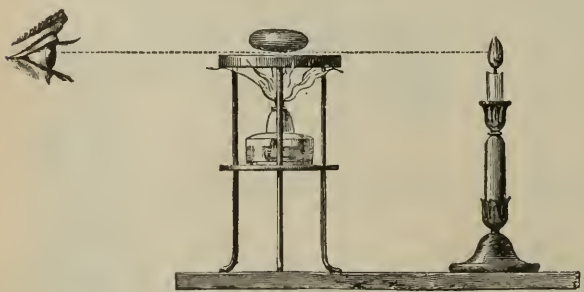

Fig. 380

and dropping on it a little dark-coloured water. The liquid assumed the spheroidal condition, and the flame of a candle placed at some distance could be distinctly seen between the drop and the plate

(fig. 380). If a plate perforated by several fine holes is heated, a liquid will assume the spheroidal state when projected upon it. This is also the case with a flat helix of platinum wire pressed into a slightly concave shape. An experiment of another class, due to Professor Church, also illustrates the same fact. A polished silver dish is made red-hot, and a few drops of a solution of sodium sulphide are projected on it. The liquid passes into the spheroidal condition, and the silver undergoes no alteration. But if the dish is allowed to cool, the liquid instantly moistens it, producing a dark spot, due to the formation of silver sulphide. In like manner nitric acid

assumes the spheroidal state when projected on a heated silver plate, and does not attack the metal so long as the plate remains hot.

An analogous phenomenon is observed when potassium is placed on water. Hydrogen is liberated, and burns with a yellow flame; potassium hydrate, which is formed at the same time, floats on the surface without touching it, owing to its high temperature. In a short time it cools down, and the globule, coming in contact with water, bursts with an explosion.

Similarly, liquids may be made to roll upon liquids, and solid bodies which vaporise without becoming liquid also assume a condition analogous to the spheroidal state of liquids when they are placed on a surface whose temperature is sufficiently high to vaporise them rapidly. This is seen when a piece of ammonium carbonate is placed in a red-hot platinum crucible.

The phenomena of the spheroidal state seem to prove that the liquid globule rests upon a sort of cushion of its own vapour, produced by the heat radiated from the hot surface against its under side. As fast as this vapour escapes from under the globule, its place is supplied by a fresh quantity formed in the same way, so that the globule is constantly buoyed up by it, and does not come in actual contact with the heated surface. When, however, the temperature of the latter falls, the formation of vapour at the under surface becomes less and less rapid, until at length it is not sufficient to prevent the globule touching the hot metal or liquid on which it rests. As soon as contact occurs, heat is rapidly imparted to the globule, it enters into ebullition, and quickly boils away.

This explanation is confirmed by the experiments of Budde, who found that in an exhausted receiver water passes into the spheroidal state, even when the temperature of the support is not more than 80° or 90° ; for then the vapour has only to support the drop, and not the atmospheric pressure also.

These experiments on the spheroidal state explain the fact that the hand may be dipped into melted lead, or even melted iron, without injury. It is necessary that the liquid metal be heated greatly above its solidifying point. Usually the natural moisture of the hand is sufficient, but it is better to wipe it with a damp cloth. In consequence of the great heat the hand becomes covered with a layer of spheroidal fluid, which prevents the contact of the metal with the hand. Radiant heat alone operates, and this is principally expended in forming aqueous vapour on the surface of the hand. If the hand is immersed in boiling water, the water adheres to the flesh, and consequently a scald is produced.

The tales of ordeals by fire during the middle ages, of men who could run barefooted over red-hot iron without being injured, are possibly true in some cases, and would find an explanation in the preceding phenomena.

DENSITY OF VAPOURS

391. **Gay-Lussac's method.**—The *density of a vapour* is the relation between the weight of a given volume of this vapour and that of the same volume of air at the same temperature and pressure.

The older methods used in determining the density of vapours are: Gay-Lussac's, which serves for liquids that boil at about 100° , and Dumas', which can be used up to 350° .

Fig. 381 represents the apparatus used by Gay-Lussac. It consists of an iron vessel containing mercury, in which there is a glass cylinder M. This is filled with water or oil, and the temperature is indicated by the thermometer T. In the interior of the cylinder is a graduated gas jar C, which at first is filled with mercury.

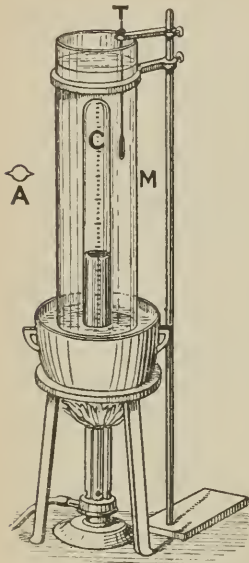

Fig. 381

The liquid whose vapour-density is to be determined is placed in a small glass bulb B, represented on the left of the figure. The bulb is then sealed and weighed; the weight of the liquid taken is obviously the weight of the bulb when filled, minus its weight while empty. The bulb is then introduced into the jar C, and the liquid in M gradually heated somewhat higher than the boiling point of the liquid in the bulb. In consequence of the expansion of this liquid the bulb breaks, and the liquid becoming converted into vapour, the mercury is depressed, as represented in the figure. The bulb must be so small that all the liquid in it is vapourised. The volume of the vapour is given by the graduation on the jar. Its temperature is indicated by the thermometer T, and the pressure is shown by the difference between the height of the barometer at the time of the observation and the height of the

column of mercury in the gas jar. It is only necessary then to calculate the weight of a volume of air equal to that of the vapour under the same conditions of temperature and pressure. The quotient, obtained by dividing the weight of the vapour by that of the air, gives the required density of the vapour.

Let ρ be the weight of the vapour in grains, v its volume in cubic inches, and t its temperature; if H be the height of the barometer in millimetres, and h that of the mercury in the gas jar, the pressure on the vapour will be $H - h$.

It is required to find the weight ρ' of a volume of air v , at the temperature t , and under a pressure $H - h$. This is clearly

$$\frac{0.31v(H-h)}{(1+at)760} \text{ grains}$$

since 1 cubic inch of air weighs 31 grains. See problem iii. (389).

Consequently, for the desired density we have

$$D = \frac{\rho}{\rho'} = \frac{\rho(1+at)760}{0.31v(H-h)}$$

If volume is measured in cubic centimetres and weight in grammes, the formula becomes

$$D = \frac{\rho(1+at)760}{0.01293v(H-h)}$$

392. **Hofmann's method.**—Hofmann materially improved the method of Gay-Lussac by having the mercury tube *fb*, in which the vapour is produced, about a metre in length (fig. 382); it is, in fact, a barometer, and the vapour is formed in the Torricellian vacuum. This tube is surrounded by another glass tube *a*, which is connected, by a bent tube *c*, with a canister *e*, so that water, amylic alcohol, or aniline, or, indeed, any substance with a constant boiling point, may be distilled through the tube *a*, the vapour being carried off by the tube *d*, which is connected with a condensing arrangement not represented in the figure. In this way more constancy in the temperatures is ensured than with the use of a mercury bath. The liquid is contained in very minute stoppered tubes, *h*, holding from 20 to 100 milligrammes of water; the stoppers come out in the vacuum, and the tubes can be used over again.

As, under the above conditions, the liquid vaporises into a vacuum, the vapour is formed under a very much lower pressure than that of the atmosphere, and therefore at a temperature much below its ordinary boiling point. Thus, the vapour-density of a body which only boils at a temperature of 150° can be determined at the temperature of boiling water. This is of great use in the case of those bodies which decompose at their boiling point under the ordinary atmospheric pressure.

393. **Dumas' method.**—The original method of Gay-Lussac cannot be applied to liquids whose boiling point exceeds 150° or 160° . In order to raise the oil in the cylinder to this temperature it would be necessary to heat the mercury to such a degree that its vapour would be dangerous to the operator. And, moreover, the pressure of the mercurial vapour in the graduated jar would add itself to that of the vapour of the liquid, and so far vitiate the result.

The following method, devised by Dumas, can be used up to the temperature at which glass begins to soften; that is, about 400° . A glass globe is used with the neck drawn out to a fine point (fig. 383). The globe, having been dried externally and internally, is weighed, the temperature *t* and barometric height *h* being noted. This weight, *W*, is the weight of the glass, *G*, in addition to *p*, the weight of the air it contains. The globe is then gently warmed, and its point immersed in the liquid whose vapour-density is to be determined; on cooling, the air contracts, and a quantity of liquid enters the globe. The globe is then immersed in a bath, either

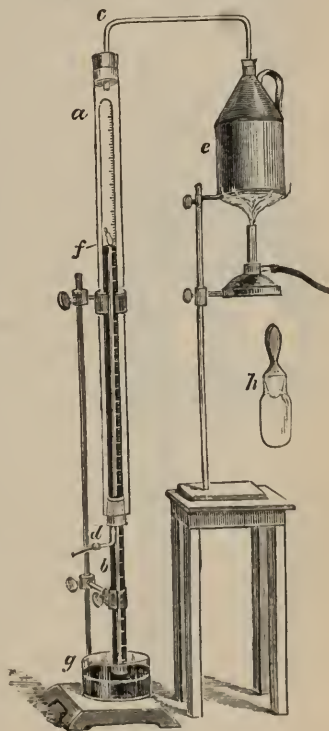

Fig. 382

of oil or fusible metal, according to the temperature to which it is to be raised. In order to keep the globe in a vertical position a metal support, on which a movable rod slides, is fixed on the side of the vessel. This rod has two rings, between which the globe is placed, as shown in the figure. There is another rod, to which a weight thermometer, D (325), is attached.

The globe and thermometer having been immersed in the bath, the latter is heated until slightly above the boiling point of the liquid in the globe. The vapour which passes out by the point expels all the air in the

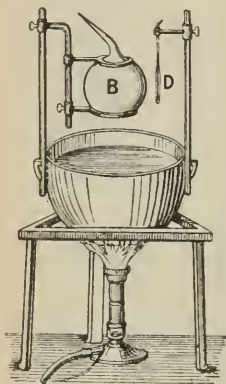

Fig. 383

interior. When the jet of vapour ceases, which is the case when all the liquid has been converted into vapour, the point of the globe is hermetically sealed, the temperature of the bath t' , and the barometric height h' , being noted. When the globe is cooled it is carefully cleaned and again weighed. This weight, W' , is that of the glass G , plus ϕ' , the weight of the vapour which fills the globe at the temperature t' , and pressure h' , or $W' = G + \phi'$. To obtain the weight of the glass alone, the weight ϕ of air must be known, which is determined in the following manner:—The point of the globe is placed under mercury and the extremity broken off with a small pair of pincers: the vapour being condensed, a vacuum is produced, and mercury rushes up, completely filling the globe, if, in the experiment, all the air has been entirely expelled. The

mercury is then poured into a carefully graduated measure, which gives the volume of the globe. From this result, the volume of the globe at the temperature t' may be easily calculated, and consequently the volume of the vapour. From this determination of the volume of the globe, the weight ϕ of the air at the temperature t and pressure h is readily calculated, and this result subtracted from W gives G , the weight of the glass. Now the weight of the vapour ϕ' is $W' - G$. We now know the weight ϕ' of a given volume of vapour at the temperature t' and pressure h' , and it is only necessary to calculate the weight ϕ'' of the same volume of air under the same conditions, which is easily accomplished. The quotient $\frac{\phi'}{\phi''}$ is the required density of the vapour.

Deville and Troost modified Dumas' method so that it can be used for determining the vapour-density of liquids with very high boiling points. The globe is heated in an iron cylinder in the vapour of mercury or of sulphur, the temperatures of which are constant respectively at 357° and 444° . In other respects the determination is the same as in Dumas' method.

For determinations at higher temperatures, Deville and Troost employed the vapour of zinc, the temperature of which is 916° . As glass vessels are softened at this temperature, they used porcelain globes with finely drawn-out necks, which are sealed by means of the oxyhydrogen flame.

In the case of substances having a high boiling point, Victor Meyer has advantageously used a non-volatile substance, Wood's fusible alloy, which melts at 68° , instead of mercury. Habermann has introduced into Dumas'

method Hofmann's modification of Gay-Lussac's, by connecting the open end of the vessel B (fig. 383) with a space in which a partial vacuum is made. Thus the vapour-density can be determined for temperatures far below the boiling point.

A method of determining vapour-density, much in use, is that devised by Victor Meyer. A long glass tube *b* with an enlargement at the top is fixed to the cylindrical vessel, A, which has a capacity of about 100 c.c. Near the top of *b* a gas delivery tube, *a*, is fused, and opposite this another tube, *e*, closed by a bit of india-rubber tubing in which a metal rod, *g*, can be moved airtight. On the rod rests a small thin vessel, containing the substance whose vapour-density is to be determined. For very volatile liquids small bulbs, *k*, of very thin glass are used; they are filled by being fitted through a cork to a tube in which the liquid is placed, as shown on the right of fig. 384. When *k* is heated, air is driven out of it; and on cooling, *k* is filled with liquid and the end *f* is fused.

The cork being inserted, the whole apparatus is suspended in the long glass vessel *rr*₁, which contains a liquid of constant boiling point such as aniline or diphenyl (366). This is heated until it boils constantly, which is known when no air bubbles issue from the delivery tube *a*. The vapours from this tube issue through the bent tube shown in the figure, and are connected with a condensing arrangement not shown. When this state of things is attained a graduated tube, *m*, filled with water is pushed over the open end of the tube *a*. The rod *g* is then withdrawn and the small vessel falls and is broken, some asbestos being placed at the bottom to prevent a possible breakage of the vessel A itself. When the substance vapourises a corresponding volume of air issues and is collected in the tube *m*. When no more issues the tube is placed in a cylinder of water and is depressed until the level inside and outside is the same. The volume *v* is read off, also the temperature of the water, *t*, and the barometric height *H*. These data, together with the weight of the substance *p*, and *h* the pressure of aqueous vapour at *t*, enable us to calculate the density from the formula

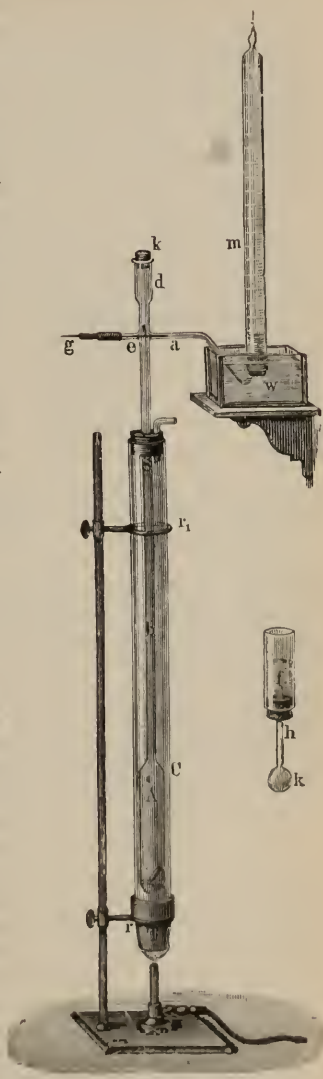

Fig. 384

$$D = \frac{\phi}{\phi'} = \frac{\phi \times 760 (273 + t)}{v(0.001293) (H - h) 273} = \frac{\phi (273 + t) 2152}{v (H - h)}$$

where ϕ , ϕ' are expressed in grammes, and v in cubic centimetres.

In this case a calorimetric determination of the temperature is made by dipping a piece of platinum in the liquid. The volume of the vapour is obtained in the form of an equal volume of air measured at the temperature of the room, and thus neither the capacity of the vessel b nor the temperature of the vapour need be known, unless it be desired to investigate in what respect the density varies with the temperature.

394. **Relation of vapour-density to molecular weight. Dissociation.**—The densities of vapours, determined at temperatures a few degrees above their boiling points, and when they may be considered as obeying the gaseous laws, are governed by a simple but very important law, that *the densities of vapours are proportional to their molecular weights*. If both densities and molecular weights are referred to the same standard, that of hydrogen being taken as 2 for instance, the *vapour-densities are equal to the molecular weights*. If the density of air is taken as 1, that of hydrogen is $0.0693 = \frac{1}{28.86}$, and hence for all other gases and superheated vapours the density is $\frac{1}{28.85}$ of the molecular weight.

This law is of great importance in chemistry in fixing the molecular weights of bodies, more especially in organic chemistry. In some cases exceptions are met with; these, when small, may be ascribed to imperfection of the gaseous state. A more important cause is the following:—When sal-ammoniac, NH_4Cl , for instance, is strongly heated, it is resolved into ammonia, NH_3 , and hydrochloric acid, HCl , and it then occupies a volume double that required by the law. But there is a partial decomposition even at lower temperatures, so that the vapour consists of molecules of sal-ammoniac, mixed with molecules of free hydrochloric acid and of free ammonia. In such cases the vapour-density is said to be *abnormal*; and this partial decomposition in which there is a mixture of undecomposed and of decomposed molecules, is spoken of as *dissociation*. Thus, sulphuric acid, SO_4H_2 , at 325° , consists of about one half undecomposed molecules, while the other moiety decomposes into sulphuric anhydride, SO_3 , and water, H_2O . The dissociation of water begins at 1200°C ., and is complete at 2500° . Stannic chloride, SnCl_4 , has the theoretical density 6.53. At 600° the density corresponds to the formula Sn_2Cl_4 ; as the temperature rises this diminishes, and at 1000° it represents the formula SnCl_2 . It appears thus that the vapour exists in two forms: at 600° as Sn_2Cl_4 , and at 1000° as SnCl_2 ; as the temperature rises from 600° the molecule Sn_2Cl_4 is more and more dissociated, until at 1000° it is completely resolved into 2SnCl_2 .

Dissociation does not take place suddenly, but gradually; it increases with the temperature, and is limited by the tendency of the components to recombine; for each temperature the quantity dissociated is in a constant ratio to the whole. As the temperature sinks, the bodies again recombine, and at the initial temperature the body is in its original state. In this respect dissociation differs from decomposition. The temperature at which the decomposition is half completed is taken as that of dissociation.

Dissociation is also met with in elementary bodies: thus at a tempera-

ture of 500° C. sulphur has the vapour-density 96 ($H=1$), representing a molecular weight of 192; as the temperature increases this becomes less, and from 1000° it is constant, being then 32, which is normal, corresponding to a molecular weight of 64. At the lower temperature the molecule is considered to be an aggregate consisting of six atoms or three molecules, while at higher temperatures this complex splits up, and at 1000° consists of the normal diatomic molecule. In like manner the density of iodine vapour, which up to 600° is 8.716, is only 4.5, or about half as much, at 1500° , but then remains constant. This probably represents a dissociation of the iodine molecule, I_2 , into two atoms.

Densities of vapours

Air	1.0000	Vapour of phosphorus	4.3256
Vapour of water	0.6225	„ turpentine	5.0130
„ alcohol	1.6138	„ anthracene	6.0100
„ acetic acid	2.0800	„ sulphur	6.6542
„ carbon bisulphide	2.4476	„ mercury	6.9760
„ ether	2.5860	„ chrysene	8.1200
„ benzole	2.7290	„ iodine	8.7160
„ aniline	3.3100	„ perchloriphenyl	17.4300

The density of aqueous vapour, when a space is saturated with it, is at all temperatures $\frac{1}{773}$, or, more accurately, 0.6225, of the density of air at the same temperature and pressure.

395. **Relation between the volume of a liquid and that of its vapour.**—The density of vapour being known, we can readily calculate the ratio between the volume of a vapour in the saturated state at a given temperature and that of its liquid at zero. We may take as an example the relation between water at zero and steam at 100° .

The ratio between the weights of equal volumes of air at zero, and the normal barometric pressure, and of water under the same circumstances, is as 1 : 773. But from what has been already said (335), the density of air at zero is to its density at 100° as $1 + at$: 1. Hence the ratio between the weights of equal volumes of air at 100° and water at 0° is

$$\frac{1}{1 + 0.003665 \times 100} : 773, \text{ or } 0.73178 : 773.$$

Now from the above table the density of steam at 100° C., and the normal pressure, compared with that of air under the same circumstances, is as 0.6225 : 1. Hence the ratio between the weights of equal volumes of steam at 100° and water at 0° is

$$0.73178 \times 0.6225 : 773, \text{ or } 0.4555 : 773, \text{ or } 1 : 1698.$$

Therefore, as the volumes of bodies are inversely as their densities, one volume of water at zero expands into 1698 volumes of steam at 100° C. The practical rule, that a cubic inch of water yields a cubic foot of steam, though not quite accurate, expresses the relation in a convenient form.

CHAPTER VI

HYGROMETRY

396. **Province of hygrometry.**—The province of *hygrometry* is to determine the quantity of aqueous vapour contained in a given volume of air. This quantity is very variable; but the atmosphere is seldom or never completely saturated with vapour, even in our climate. Nor is it ever completely dry; for if *hygrometric substances*—that is to say, substances with a great affinity for water, such as calcium chloride, sulphuric acid, &c.—be at any time exposed to the air, they absorb aqueous vapour.

397. **Hygrometric state.**—As the air is, in general, never saturated, the ratio of the quantity of aqueous vapour actually present in a given volume of atmospheric air to that which it would contain if it were saturated, the temperature remaining the same, is called the *hygrometric state*, or *relative humidity of the air*.

The *absolute moisture* is measured by the weight of water actually present in the form of vapour in the unit of volume.

We say the 'air is dry' when water evaporates and moist objects dry rapidly; and the 'air is moist' when they do not dry rapidly, and when a slight lowering in temperature brings about deposits of moisture. The air is dry or moist according as it is more or less distant from its point of saturation. Our judgment is, in this respect, independent of the absolute quantity of moisture in the air. Thus, if in summer, at a temperature of 25° C., we find that each cubic metre of air contains 13 grammes of vapour, we say it is very dry, for at this temperature it could contain 22·5 grammes. If, on the other hand, in winter we find that the same volume contains 6 grammes, we call it moist, for it is nearly saturated with vapour, and the slightest diminution of temperature produces a deposit. When a room is warmed, the quantity of moisture is not diminished, but the humidity of the air is lessened, because its point of saturation is raised. The air may thus become so dry as to be injurious to the health, and hence it is usual to place vessels of water on the stoves used for heating.

As Boyle's law applies to non-saturated vapours as well as to gases (357), it follows that, with the same temperature and volume, the weight of vapour in an unsaturated space increases with the pressure, and therefore with the pressure of the vapour itself. Instead, therefore, of the ratio of the quantities of vapour, that of the corresponding pressures may be substituted, and it may be said that the hygrometric state is *the ratio of the elastic force or pressure of the aqueous vapour which the air actually contains, to the elastic force of the vapour which it would contain at the same temperature if it were saturated.*

If f is the actual pressure of aqueous vapour in the air, F the maximum pressure at the same temperature, t , and E the hygrometric state; also, if d_o is the density of aqueous vapour at o° , w the weight of the vapour occupying the volume v , and W the weight which the vapour would have if the space were saturated, we have

$$w = \frac{v_o d}{1 + at} \cdot \frac{f}{760}, \quad W = \frac{d_o v}{1 + at} \cdot \frac{F}{760}; \quad \text{therefore } E = \frac{w}{W} = \frac{f}{F}.$$

As a consequence of this second definition, it is important to notice that, the temperature having varied, the air may contain the same quantity of vapour and yet not have the same hygrometric state. For, when the temperature rises, the pressure of the vapour which the air would contain, if saturated, increases more rapidly than the pressure of the vapour actually present in the atmosphere, and hence the ratio between the two pressures—that is to say, the hygrometric state—becomes smaller. This also follows from the formula $E = w/W$; for though w may remain constant on rise of temperature, W will be greater.

Jamin proposed to replace this ratio $\frac{f}{F}$, which expresses the relative moisture, by the ratio $\frac{f}{H - f}$, in which H is the barometric height; he calls this the *hygrometric richness*, and contends that it brings out changes in the quantity of moisture present in the air with greater distinctness.

It will presently be explained (407) how the weight of the vapour contained in a given volume of air may be deduced from the hygrometric state.

398. **Different kinds of hygrometers.**—*Hygrometers* are instruments for measuring the hygrometric state of the air. There are numerous varieties of them—chemical hygrometers, condensing hygrometers, and psychrometers.

399. **Chemical hygrometer.**—The method of the chemical hygrometer consists in passing a known volume of air over a substance which readily absorbs moisture—calcium chloride, for instance. The substance having been weighed before the passage of air, and then afterwards, the increase in weight represents the amount of aqueous vapour present in the air. By means of the apparatus represented in fig. 385 it is possible to examine any given volume of air. Two brass reservoirs, A and B, of the same size and construction, act alternately as aspirators, by being fixed to the same axis, about which they can turn. They are connected by a central tubulure, and by means of two tubulures in the axis the lower reservoir is always in connection with the atmosphere, while the upper one, by means of an india-rubber tube, is connected with two U tubes, N and M, filled either with calcium chloride or with pumice-stone impregnated with sulphuric acid. The first absorbs the vapours in the air drawn through, while the other, M, stops any vapour which might diffuse from the reservoirs into the tube N.

The lower reservoir being full of water, and the upper one of air, the apparatus is inverted so that the liquid flows slowly from A to B. A partial vacuum being formed in A, air enters by the tubes NM, in the first of which all the vapour is absorbed. When all the water is run into B the apparatus is inverted; the same flow recommences, and the same volume of air is drawn through the tube N. Thus, if each reservoir holds 5 litres, for

example, and the apparatus has been turned five times, 30 litres of air have traversed the tube N and have been dried. If then, before the experiment, the tube with its contents has been weighed, the increase of weight gives the weight of aqueous vapour present in 30 litres of air at the time of the experiment.

Edelmann has devised a new form of hygrometer, the principle of which is to enclose a given volume of air, and then to absorb the aqueous vapour

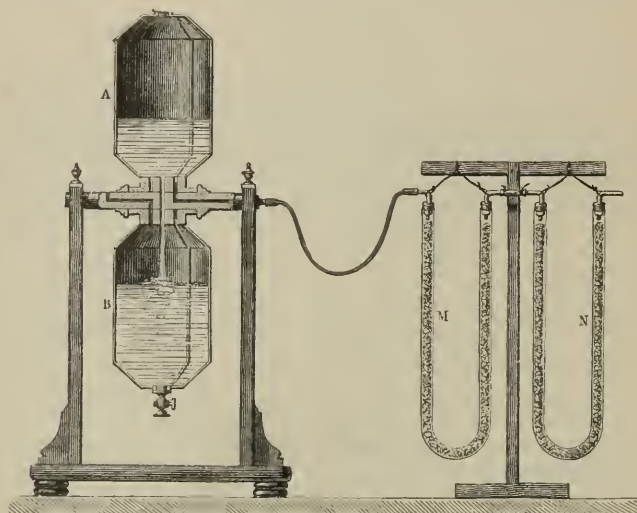

Fig. 385

present by means of strong sulphuric acid ; in this way diminution in the pressure is produced which is determined, and is a direct measure of the pressure f of the aqueous vapour previously present.

Similar apparatus have been devised by Rudorff and by Neesen.

400. **Condensing hygrometers.**—When a body gradually cools in a moist atmosphere—as, for instance, when a lump of ice is placed in water contained in a polished metal vessel—the layer of air in immediate contact with it cools also, and a temperature is ultimately reached at which the vapour present is just sufficient to saturate the air ; the least diminution of temperature then causes a precipitation of moisture on the vessel in form of dew. When the temperature rises again, the dew disappears. The mean of these two temperatures is taken as the *dew-point*, and the object of *condensing* hygrometers is the determination of this point. Daniell's and Regnault's hygrometers belong to this class.

401. **Daniell's hygrometer.**—This consists of two glass bulbs at the extremities of a glass tube bent twice (fig. 386). The bulb A is two-thirds full of ether, and a very delicate thermometer is plunged in it ; the rest of the space contains nothing but the vapour of ether, the ether having been boiled before the bulb B was sealed. The bulb B is covered with muslin, and ether is dropped upon it. The ether in evaporating cools the bulb, and the

vapour contained in it is condensed. The internal pressure being thus diminished, the ether in A forms vapour which condenses in the other bulb B. In proportion as the liquid distils from the lower to the upper bulb, the ether in A becomes cooler, and ultimately the temperature of the air in immediate contact with A sinks to that point at which its vapour is more than sufficient to saturate it, and it is, accordingly, deposited on the outside as a ring of dew on a level with the surface of the ether. The temperature at which this occurs is noted by means of the thermometer in the inside. The addition of ether to the bulb B is then discontinued, the temperature of A rises, and the temperature at which the dew disappears is noted. In order to render the deposition of dew more perceptible, the bulb A is made of black glass.

These two points having been determined, their mean is taken as that of the dew-point. The temperature of the air at the time of the experiment is indicated by the thermometer on the stem. The pressure f , corresponding to the temperature of the dew-point, is then found in the table of pressures (361). This pressure is exactly that of the vapour present in the air at the time of the experiment. The pressure F of vapour saturated at the temperature of the atmosphere is found by means of the same table; the quotient obtained by dividing f by F represents the hygrometric state of the air (397). For instance, the temperature of the air being 15° , suppose the dew-point is 5° . From the table the corresponding pressures are $f = 6.534$ millimetres, and $F = 12.699$ millimetres, which gives 0.514 for the ratio of f to F , or the hygrometric state.

There are many sources of error in Daniell's hygrometer. The principal are: 1st, that as the evaporation in the bulb A only cools the liquid on the surface, the thermometer dipping in it does not exactly give the dew-point; 2nd, that the observer standing near the instrument modifies the hygrometric state of the surrounding air, as well as its temperature; the cold ether vapour also flowing from the upper bulb may cause inaccuracy. 3rd, glass is a bad conductor of heat, hence the temperature of deposition of dew may be different from that indicated by the thermometer.

402. **Regnault's hygrometer.**—Regnault's hygrometer consists of two very thin polished silver thimbles 4 cm. in height and 2 cm. in diameter (fig. 387). In these are fixed two glass tubes D and E, in each of which is a thermometer. A bent tube, A, open at both ends, passes through the cork of the tube D, and reaches nearly to the bottom of the thimble. There is a tubulure on the side of D, fitting in a brass tube which forms a support for

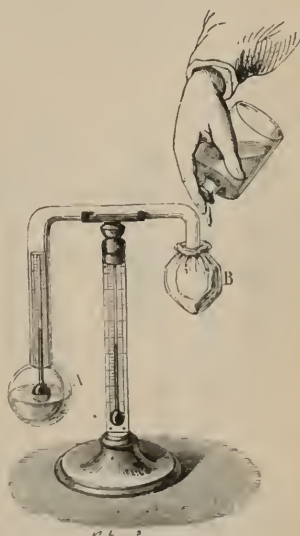

Fig. 386

the apparatus. The end of this tube is connected with an aspirator G. The tube E is not connected with the aspirator; its thermometer simply indicates the temperature of the atmosphere.

The tube D is then half filled with ether, and the stopcock of the aspirator opened. The water contained in it runs out, and just as much air enters through the tube A, bubbling through the ether, and causing it to evaporate. This evaporation produces a diminution of temperature, so that dew is deposited on the silver just as on the bulb in Daniell's hygrometer; the thermometer T is then instantly to be read, and the stream from the aspirator stopped. The dew will soon disappear again, and the thermometer T is again to be read; the mean of the two readings is taken; the thermometer *t* gives the corresponding temperature of the air, and hence there are all the elements necessary for calculating the hygrometric state.

As all the ether in this instrument is at the same temperature in consequence of the agitation, and the temperatures may be read off at a distance

by means of a telescope, and as the silver is thin and a good conductor of heat, the sources of error in Daniell's hygrometer are avoided.

A much simpler form of the apparatus may be constructed out of a common test-tube containing a depth of $1\frac{1}{2}$ inch of ether. The tube is provided with a loosely fitting cork in which are a delicate thermometer and a narrow bent tube dipping in the ether. On blowing into the ether through an india-rubber tube of considerable length, a diminution of temperature is

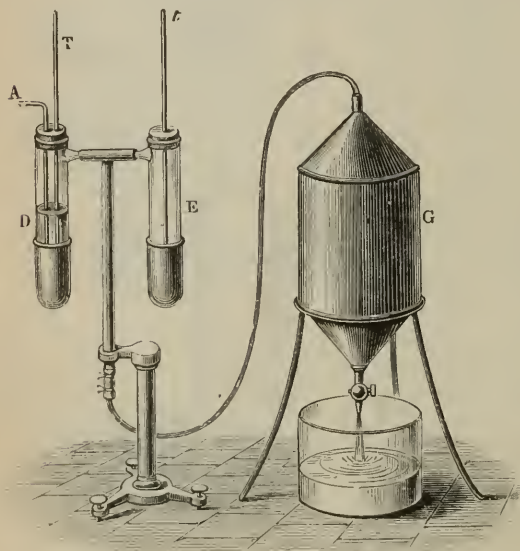

Fig. 387

caused, and dew is ultimately deposited on the glass; after a little practice the whole process can be conducted almost as well as with Regnault's more complete instrument. The temperature of the air is indicated by a detached thermometer.

403. **Dines's hygrometer.**—Dines constructed an hygrometer which is also one of condensation, but which dispenses with the use of such volatile liquids as ether. The principle of this instrument is to have a thin flat metal box, through which a small stream of cooled water is allowed to flow for a few seconds. The dew is deposited on the top of the box, which is of thin dark polished metal. By alternately stopping the flow and allowing

it to continue, the disappearance and formation of the dew may be very accurately observed, and the corresponding temperatures read off by a delicate thermometer placed inside.

404. **Psychrometer. Wet-bulb hygrometer.**—A moist body evaporates in the air more rapidly in proportion as the air is drier, and the temperature of the body sinks in consequence of this evaporation. The *psychrometer*, or *wet-bulb hygrometer*, is based on this principle, the application of which to this purpose was first suggested by Leslie. The form usually adopted in this country is due to Mason. It consists of two delicate thermometers placed on a wooden stand (fig. 388). One of the bulbs is covered with muslin, and is kept continually moist by being connected with a reservoir of water by means of a string. Unless the air is saturated with moisture the wet-bulb thermometer always indicates a lower temperature than the other, and the difference between the indications of the two thermometers is greater in proportion as the air can take up more moisture, and is therefore drier. The pressure f of the aqueous vapour in the atmosphere may be calculated from the indications of the two thermometers by means of the following empirical formula :—

$$f = f' - 0.00077(t - t')h,$$

in which f is the maximum pressure corresponding to the temperature of the wet-bulb thermometer, 0.00077 is a constant, h is the barometric height, and t and t' the respective temperatures of the dry and wet bulb thermometers. If, for example, $h = 750$ millimetres, $t = 15^\circ$ C., $t' = 10^\circ$ C.; according to the table of pressures (361), $f' = 9.165$, and we have

$$f = 9.165 - 0.00077 \times 5 \times 750 = 6.342.$$

This pressure corresponds to a dew-point of about 4.5° C. If the air had been saturated, the pressure would have been 12.699, and the air is therefore about half saturated with moisture.

This formula expresses the result with tolerable accuracy, but the above constant 0.00077 requires to be controlled for different positions of the instrument; in small closed rooms it is 0.00128, in large closed rooms 0.00100; the number 0.00077 is its value in a large room with open windows. Regnault found that the difference in temperature of the two bulbs depends on the rapidity of the current of air; he also found that at a low temperature and in very moist air the results obtained with the psychrometer differed from those yielded by his hygrometer. It is probable that the indications of the psychrometer are only true for mean and high temperatures, and when the atmosphere is not too moist.

A formula frequently used in this country is that given by Dr. Apjohn. It is

$$F = f - \frac{d}{88} \times \frac{h}{30}, \text{ or } F = f - \frac{d}{96} \times \frac{h}{30},$$

in which d is the difference of the wet and dry bulb thermometers in *Fahrenheit* degrees; h the barometric height in *inches*; f the pressure of

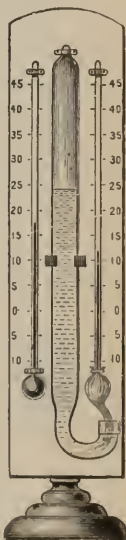

Fig. 388

vapour for the temperature of the *wet bulb*, and *F* the pressure of vapour at the dew-point, both in inches, from which the dew-point may, if necessary, be found from the tables. The constant coefficient 88 is to be used when the reading of the wet bulb is above 32° F., and 96 when it is below.

According to Glaisher the temperature of the dew-point may be obtained by multiplying the difference between the temperatures of the wet and dry bulb by a constant depending on the temperature of the air at the time of observation, and subtracting the product thus obtained from this last-named temperature. The following table gives the numbers, which are known as *Glaisher's factors*.

Dry bulb Temperature F.°	Factor	Dry bulb Temperature F.°	Factor
Below 24°	8.5	34 to 35	2.8
24 to 25	6.9	35—40	2.5
25—26	6.5	40—45	2.2
26—27	6.1	45—50	2.1
27—28	5.6	50—55	2.0
28—29	5.1	55—60	1.9
29—30	4.6	60—65	1.8
30—31	4.1	65—70	1.8
31—32	3.7	70—75	1.7
32—33	3.3	75—80	1.7
33—34	3.0	80—85	1.6

405. **Absorption hygrometers.**—These hygrometers are based on the property which organic substances have of elongating when moist, and of again contracting as they become dry. The most common form is the *hair* or *Saussure's hygrometer*.

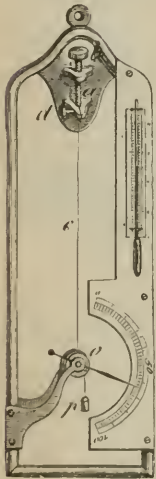

Fig. 389

It consists of a brass frame (fig. 389), on which is fixed a hair, *c*, fastened at the top in a clamp, *a*, provided with a screw, *d*. This clamp is moved by a screw, *b*. The lower part of the hair passes round a pulley, *o*, and supports a small weight *p*. On the pulley there is a needle, which moves along a graduated scale. When the hair becomes shorter the needle rises, when it becomes longer the weight *p* makes it sink.

The scale is graduated by calling that point zero at which the needle would stand if the air were completely dry, and 100 the point at which it stands in air completely saturated with moisture. The distance between these points is divided into 100 equal degrees.

Regnault devoted much study in order to render the hair hygrometer scientifically useful, but without much success. The utmost that can be claimed for it is that it can be used as a *hygroscope*; that is, an instrument which shows approximately whether the air is more or less moist, without giving any indication as to the quantity of moisture present. To this class of hygrosopes belong the chimney

ornaments, one of the most common forms of which consists of figures representing a man and a woman, so arranged in reference to a little house with two doors, that when it is moist the man comes out and the woman goes in, and *vice versâ* when it is fine. They are founded on the property which twisted strings or pieces of catgut possess of untwisting when moist, and of twisting when dry. As these hygrosopes only change slowly, their indications are always behindhand with the state of the weather; nor are they, moreover, very exact.

A strip of drawing-paper, coated on one side with gelatine and varnished on the other, readily absorbs moisture, so that the strip curves outwards on the gelatine side, like the compensating strips in (321), when heated. If such a strip is coiled as a spiral, then, according to the greater or less quantity of moisture it absorbs, the spiral twists and untwists like a Breguet's thermometer (310), and thus serves as a sensitive hygroscope.

406. **Moisture of the atmosphere.**—The absolute moisture varies with the temperature in the course both of the year and of the day. In summer there is a maximum at eight in the morning and evening, and a minimum at 3 P.M. and 3 A.M., because the ascending current of air carries the moisture upwards. The *absolute* moisture is greatest in the tropics, where it represents an average pressure of 25 mm., while in our latitudes it does not exceed 10 mm. The relative moisture, on the other hand, is on the average greater in high than in low latitudes; it is at the minimum in the hottest and at its maximum in the coolest part of the day. It varies also in different regions. It is less in the centre of continents than it is on the sea or the sea-coast. Thus in summer the relative humidity or hygrometric state at Greenwich is 77, at Venice 64, Lugano 58, and Uralsk 42 per cent. That the dryness increases with the distance from the sea is shown by the clearer skies of continental regions. In Platowskya in Siberia the air, at a temperature of 24° , was found to contain a quantity of moisture only sufficient to saturate it at -3° ; the air might therefore have been cooled through 27° without any deposit of moisture. On the ground the absolute humidity is greatest, and diminishes rapidly as we ascend; the relative humidity however increases, so that at a certain height the air is saturated with moisture. From this zone upwards the relative moisture decreases, for the aqueous vapour is confined to the lower regions. In some parts of East Africa the springs of powder-flasks exposed to the damp snap like twisted quills; paper, on the contrary, becomes soft and sloppy by the loss of its glaze, and gunpowder, if not kept hermetically sealed, refuses to ignite. On the other hand, in North America, where the south-west winds blow over large tracts of land, the relative moisture is less and the evaporation is far more rapid than in Europe; clothes dry quickly, bread soon becomes hard, newly built houses can be at once inhabited, European pianos soon give way there, while American ones are very durable on this side of the ocean. As regards the animal economy, liquids evaporate more rapidly, by which the circulation and the assimilation are accelerated, and the whole character is more nervous. For evaporation is quicker the drier the air, and the more frequently it is renewed; it is, moreover, more rapid the higher the temperature, and the less the pressure. This is not in disaccord with the statement that the quantity of vapour which saturates a given space is the

same however this be filled with air ; a certain space takes up the same weight of vapour whether it is vacuous, or filled with rarefied or dense air ; the saturation with vapour takes place the more rapidly the lower the pressure of the air.

407. **Problem on hygrometry.**—To calculate the weight P of a volume of moist air V , the hygrometric state of which is E , the temperature t , and the pressure H , the density of aqueous vapour being $\frac{5}{8}$ that of air under the same conditions.

From the second law of the mixture of gases and vapours, it will be seen that the moist air is nothing more than a mixture of V c.c. of dry air at t° , under the pressure $H - f$, and of V c.c. of vapour at t° and pressure f given by the hygrometric state ; these two values must, therefore, be found separately.

The formula $f = F \times E$ (397) gives the pressure f of the vapour in the air, for E has been determined, and F is found from the tables. The pressure f being known, if f' is the pressure of the dry air, $f + f' = H$, from which

$$f' = H - f = H - FE.$$

The question consequently resolves itself into calculating the weight of V c.c. of dry air at t° , and the pressure $H - FE$, and then that of V c.c. of aqueous vapour also at t° , but under the pressure FE .

The former is $\frac{001293 V}{1 + at} \cdot \frac{H - FE}{760}$; the latter $\frac{5}{8} \cdot \frac{001293 V}{1 + at} \cdot \frac{FE}{760}$.

$$\text{Hence, } P \text{ (in grammes)} = \frac{001293 V}{1 + at} \cdot \left[\frac{H - \frac{5}{8} FE}{760} \right].$$

If the air were saturated we should have $E = 1$, and the formula would thus be changed into that already found for the mixture of gases and saturated vapours (389).

This formula contains, besides the weight P , many variable quantities, V , E , H , and t , and consequently, by taking successively each of these quantities as unknown, as many different problems might be proposed.

408. **Correction for the loss of weight experienced by bodies weighed in the air.**—It has been seen in speaking of the balance that the weight which it indicates is only an apparent weight, and is generally less than the real weight. The latter may be deduced from the former when it is remembered that every body weighed in the air loses a weight equal to that of the displaced air (196). This problem is, however, very complicated, for not only does the weight of the displaced air vary with the temperature, the pressure, and the hygrometric state, but the volume of the body to be weighed, and that of the weights, vary also with the temperature ; so that a double correction has to be made : one relative to the *weights*, the other to the body weighed.

Correction relative to the weights.—In order to make this correction let P be their weight in air, and Π their weight *in vacuo* ; further, let V be the volume of these weights in cubic centimetres at 0° , D the density of the substance of which they are made, and K its coefficient of linear expansion.

The volume V becomes $V(1 + 3Kt)$ at t° ; hence this is the volume of air displaced by the *weights*. If μ is the density of air at t° C. and the pressure, H , at the time of weighing, we have

$$P = \Pi - \mu V(1 + 3Kt).$$

Replacing V by $\frac{\Pi}{D}$ (122), we have

$$P = \Pi \left[1 - \frac{\mu(1 + 3Kt)}{D} \right] \dots \dots \dots (1)$$

which gives the value, in air, of a *weight* Π , when μ is replaced by its value. But since μ is the weight of a cubic centimetre of air more or less moist, at the temperature t and the pressure H , its value may be calculated by means of the formula in the foregoing paragraph.

Correction relative to the body weighed.—Let p be the apparent weight of the body to be weighed, π its real weight *in vacuo*, d its density, k its coefficient of expansion, and t its temperature; by the same reasoning as above we have

$$p = \pi \left[1 - \frac{\mu(1 + 3kt)}{d} \right] \dots \dots \dots (2)$$

By using the method of double weighing, and balancing each of the weights p and P , placed successively in one pan, against a counterpoise p' in the other pan, we eliminate any error due to possible inequality in the length of the arms of the balance, and have finally $p = P$; hence

$$\pi \{ 1 - \mu(1 + 3kt)/d \} = \Pi \{ 1 - \mu(1 + 3Kt)/D \}$$

whence

$$\pi = \frac{\Pi \{ 1 - \mu(1 + 3Kt)/D \}}{1 - \mu(1 + 3kt)/d},$$

which solves the problem.

CHAPTER VII

CONDUCTIVITY OF SOLIDS, LIQUIDS, AND GASES

409. **Transmission of heat.**—When we stand at a little distance from a fire or other source of heat we experience the sensation of warmth. The heat is not transmitted by the intervening air; it passes through it without raising its temperature, for if we place a screen before the fire the sensation ceases to be felt. The heat from the sun reaches us in the same manner. The heat which, as in this case, is transmitted to a body from the source of heat without affecting the temperature of the intervening medium, is said to be *radiated*.

That heat can be transmitted through a medium without raising its temperature is proved by a remarkable experiment made by Prévost in 1811. Water from a spring was allowed to fall in a thin sheet; on one side of this was held a red-hot iron ball, and on the other a delicate thermometer. The temperature of the latter was observed to rise steadily, a result which could not have been due to any heating effect of the water itself, as this was cold, and was being continually renewed. It could only have been due to heat which traversed the water without raising its temperature. A similar experiment has been made by a hollow glass lens through which cold water flowed in a constant stream. The sun's rays concentrated by this arrangement ignited a piece of wood placed in the focus.

Heat is transmitted in another way. When the end of a metal bar is heated, a certain increase of temperature is presently observed along the bar. Where the heat is transmitted in the mass of the body itself, as in this case, it is said to be *conducted*. We shall first consider the transmission of heat by conduction.

410. **Conductivity of solids.**—Bodies conduct heat with different degrees of facility. *Good conductors* are those which readily transmit heat, such as are the metals; while *bad conductors*, to which class belong the resins, glass, wood, and more especially liquids and gases, offer a greater or less resistance to the transmission of heat.

A method frequently adopted for comparing heat conductivities in two metals consists in placing two similar bars of the metals end to end. Small balls of wood or marble are attached to the bars—at equal distances from the junction—by means of wax. When the junction is heated by a Bunsen burner, heat travels along each of the bars, and where a temperature of 60° is reached the wax melts and a ball falls. If iron and copper are tested in this way it is found that the balls fall, for equal distances, more quickly from

the copper than from the iron. The conclusion is that copper is a better conductor of heat than iron. What the experiment really shows is the relative rates at which a particular temperature travels along the rods. If the specific heats of the two metals were very different, it might be that the first ball would fall from the metal which was the worse conductor of the two. Thus this experiment cannot be relied upon to give in all cases a correct indication of the relative conductivity of the metal. To compare thermal conductivities we must allow the heating to go on until the flow of heat is steady, *i.e.* until the temperature at any point on the bar remains constant. Thus, if we observe, not the rate at which the balls fall, but the total number fallen from each bar, when the experiment has gone on so long that no more balls fall from either, we can obtain the relative conductivities of copper and iron by counting the number fallen on each side.

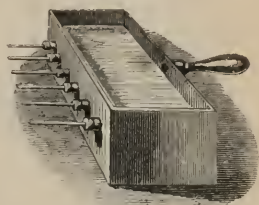

Fig. 390

Ingenhaus constructed a more convenient apparatus for this purpose which is represented in fig. 390. It is a metal trough, in which, by means of tubulures and corks, are fixed rods of the same dimensions, but of different materials; for instance, iron, copper, wood, glass. These rods extend to a slight distance in the trough, and the parts outside are coated with wax which melts at 60° . The box being filled with boiling water, it is observed that the wax melts to a certain distance on the metal rods, while on the others there is no trace of fusion. The conducting power is evidently greater in proportion as the wax has fused to a greater distance, and theory shows that the thermal conductivity is proportional to the square of the distance the wax has been melted when the heating has been continued until no further change takes place. In some forms of the apparatus the box may be closed and steam continuously passed through it, so as to maintain the ends of the rods at a temperature of 100° .

Despretz compared the conducting powers of solids by forming them into bars (fig. 391), in which small cavities are made at short intervals: these cavities contain mercury, and a delicate thermometer is placed in each of them. Such a bar, AB, is exposed at one end to a constant source of heat, such as that of a bath of paraffin or of fusible metal heated by a Bunsen's burner; the thermometers gradually rise until they indicate fixed temperatures, which are less according as the thermometers are farther from the source of heat. By this method Despretz verified the following law:—*If the distance, $a, a_1, a_2, \dots, a_{vi}$ from the source of heat increases in arithmetical progression, the excess of temperature over that of the surrounding air, $t, t_1, t_2, \dots, t_{vi}$ decreases in geometrical progression.*

This law, however, only prevails in the case of very good conductors, such as gold, platinum, silver, and copper; it is only approximately true for iron, zinc, lead, and tin, and does not apply at all to non-metallic bodies, such as marble, porcelain, &c.

By making cavities in the bars, as in Despretz's method, their form is altered, and the continuity partially destroyed. Wiedemann and Franz avoided this source of error by measuring the temperature of the bars in

different places by applying to them the junction of a thermo-electric couple (418). The metal bars were made as regular as possible, and were silver-plated and polished so as to have the same radiating or emissive power

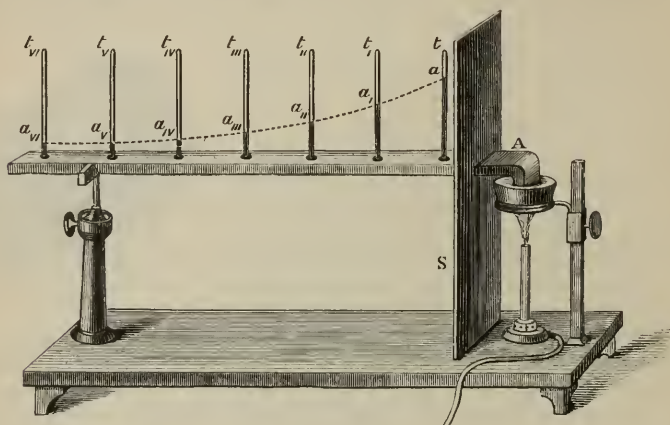

Fig. 391

(429); one of the ends was heated to 100° , the rest of the bar being surrounded by air at a constant temperature. The thermo-electric couple was of small dimensions, in order not to abstract too much heat.

By this method Wiedemann and Franz obtained results which differ considerably from those of Despretz. Representing the conductivity of silver by 1000, they found the following numbers for the relative conductivities of other metals:—

Silver	1000	Iron	120
Copper	736	Steel	116
Gold	532	Lead	85
Brass	231	Platinum	84
Zinc	190	Rose's alloy	28
Tin	145	Bismuth	18

These experimenters found that the order of the conducting powers of the pure metals for heat and electricity is the same.

It may be mentioned, however, that while the electric conductivity of all metals diminishes with rise of temperature, the thermal conductivity increases in some and diminishes in other metals.

In their experiments Despretz, and Wiedemann and Franz obtained *comparative* values of thermal conductivities. Using similar bars and modifying the experiments, Forbes, and afterwards Tait, obtained *absolute* values (411) of the conductivities of copper, iron, &c.

If a piece of wire gauze is held over a Bunsen burner the flame is seen to burn below but not above the gauze. This is not because there is no combustible gas above, but because the heat of the flame is carried away so rapidly by the metal that the temperature above the gauze does not rise

sufficiently to ignite the combustible mixture of air and coal gas. If the flame is extinguished and lighted above the gauze, the gas burns above but not below. This experiment explains the action of the Davy safety-lamp, which consists of a small oil lamp burning inside a copper gauze cylinder. The lamp may be taken with impunity into a dangerous mixture of air and fire-damp (methane). The mixture burns quietly *inside* the cylinder, but owing to the conductivity of the gauze, the temperature does not rise sufficiently outside to cause explosion.

Organic substances conduct heat badly. De la Rive and De Candolle showed that woods conduct better in the direction of their fibres than in a transverse direction, and this difference is greater with the soft than with the hard woods; they remarked upon the influence which this feeble conducting power, in a transverse direction, exerts in preserving a tree from sudden changes of temperature, enabling it to resist alike a sudden abstraction of heat from within, and a sudden accession of heat from without. Tyndall also showed that this tendency is aided by the low conducting power of the bark, which in all cases is less than that of the wood. Cotton, wool, straw, bran, &c., are all bad conductors. The conductivity of snow is about $\frac{1}{4}$ that of moist clay.

Rocks and the earth are the worse conductors the less dense and homogeneous is the mass. Hence the length of time required for the sun's heat to penetrate into the earth. The mean highest temperature of the air near the ground in Central Europe is in the month of July, but at a depth of 25 to 28 feet in the earth it is in the month of December.

411. **Coefficient of thermal conductivity.**—The numbers given in the foregoing article only express the *relative* conducting powers of the respective substances. Numerous experiments have been made to determine the *quantity* of heat, W , which passes, for instance, through a plate the two sides of which are kept at a constant difference of temperature. This will clearly be proportional to the area of the plate A and to the time t . It is further proportional to the excess of the temperature θ_1 of the one face over that of the other θ —that is, to $\theta_1 - \theta$; and as the flow of heat is different in different substances, it will be proportional to a constant k , which depends only on the nature of the substance. On the other hand it will be inversely proportional to the thickness of the plate d .

These results are expressed by the formula

$$W = \frac{k(\theta_1 - \theta)At}{d}, \text{ from which } k = \frac{Wd}{(\theta_1 - \theta)At}.$$

In the C.G.S. system of units, the *coefficient of thermal conductivity*, k , is the quantity of heat, in gramme-degrees Centigrade or calories (452), which passes in a second of time, between the two opposite faces of a cube of the substance one centimetre in thickness, the two faces being kept at a constant temperature difference of one degree. The values are as follows:

Silver	1.096	Tin	0.153
Copper	0.611	Iron	0.152
Aluminium	0.343	Lead	0.078
Zinc	0.280	Antimony	0.044

Mercury	0·016	Slate	0·003
Bismuth	0·014	Chalk	0·002
Limestone	0·005	Glass	0·0019

The conductivity of snow was found by Hjelstrom to be 0·0304.

Lamb and Wilson (1899) have determined the thermal conductivities of a number of materials with a view of testing their relative efficiency as heat insulators. They found hair-felt the most effective, its conductivity being 0·000106. As compared with this the number for air is 0·000200, for pine sawdust 0·000242, for sand 0·000740, and for silicate cotton 0·00151.

412. **Senarmont's experiment.**—It is only in isotropic bodies that heat is conducted with equal facility in all directions. If a small hole is made through a piece of ordinary glass covered with a thin layer of wax, and a platinum wire heated by an electric current passes through the aperture, the wax will be melted round the hole in a circular form. Senarmont made, on this principle, a series of experiments on the conductivity of heat in crystals. A plate cut from a crystal of the regular system was covered with wax, and a heated metallic point was held against it. The part melted had a circular form; but when plates of crystals belonging to other systems were investigated in a similar manner, it was found that the form of the *isothermal line*, or line of equal temperature—that is, the boundary of the melted part—varied with the different systems and with the position of the axes. In plates of uniaxial crystals cut parallel to the principal axis it was an ellipse (fig. 392), the major axis of which was in the direction of the principal axis. In plates cut perpendicular to the principal axis it was a circle. In biaxial crystals, for which selenite is well adapted, the line was always an ellipse. The isothermal surface agrees in general character with the wave surface of the extraordinary ray.



Fig. 392

Instead of wax the plate may be coated with the double iodide of mercury and copper; this substance is of a brick-red colour, which when heated changes into a purplish black.

Röntgen makes the experiment very simply by breathing on the plate, and then holding a hot steel point against it. When a space free from moisture has been formed about the point, the whole plate is dusted with lycopodium, which shows the outline of the figure with great sharpness.

Pfaff found the conductivity of rock crystal in the direction of the principal axis to be about 1·28 times that in the direction at right angles thereto.

The rate at which a particular temperature, *e.g.* that of melting wax (410), travels through any material is called the *diffusivity* of the material. The diffusivity depends not only upon the conductivity—to which it is directly proportional—but also upon the heat capacity of the material per unit of volume, and is measured by $k/c\rho$, where k is the conductivity, c the specific heat, and ρ the density.

413. **Conductivity of liquids.**—The conductivity of liquids is very small, as is seen from the following experiment:—A delicate thermoscope, B, con-

sisting of two glass bulbs, joined by a tube *m*, in which there is a small index of coloured liquid, is placed in a large cylindrical glass vessel, D (fig. 393). This vessel is filled with water at the ordinary temperature, and a tin vessel, A, containing oil at a temperature of two or three hundred degrees, is dipped in it. The bulb near the vessel A is only very slightly heated, and the index *m* moves through a very small distance. Other liquids give the same result. That liquids conduct very badly is also demonstrated by a simpler experiment. A long test-tube is half filled with water, and some ice so placed in it that it cannot rise to the surface. By inclining the tube and heating the surface of the liquid by means of a spirit lamp, the liquid at the top may be made to boil, while the ice at the bottom remains unmelted.

Despretz made a series of experiments with an apparatus analogous to that here described, but he kept the liquid in the vessel A at a constant temperature, and arranged a series of thermometers one below the other in the vessel D. In this manner he found that the conductivity of heat in liquid obeys the same laws as in solids, but is much more feeble.

Guthrie examined the conductivity of liquids in the following manner :— Two hollow brass cones are placed near each other so that the top of one

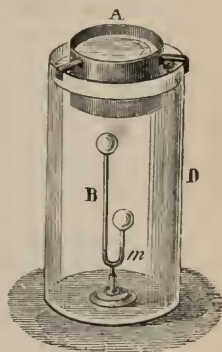

Fig. 393

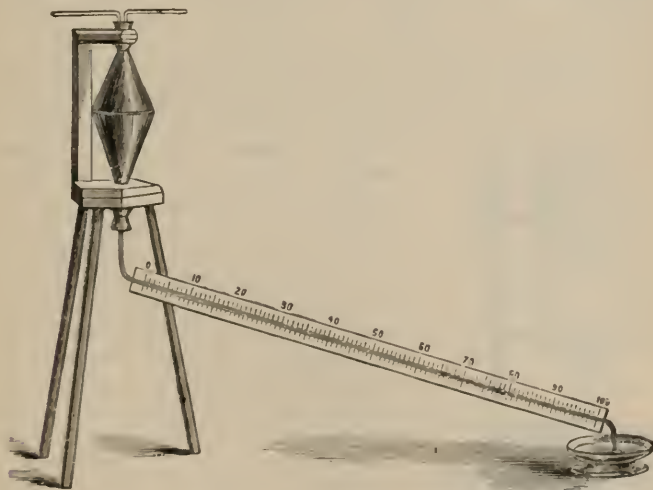

Fig. 394

points upwards, that of the other downwards (fig. 394). The distance of the bases, which are of platinum, can be regulated by a micrometer screw. The liquid to be examined is introduced between the bases by means of a pipette.

The lower cone is fitted with a glass tube which dips in a coloured liquid and thus constitutes an air thermometer. The base of the upper cone is kept at a constant temperature by means of a current of hot water; it thus warms the liquid, and the base of the lower cone, in consequence of which the air in the interior is expanded and the column of liquid in the stem depressed.

The bases of the cones were first brought in contact and the depression of the column of liquid was observed. A layer of liquid of a given thickness was then interposed and the depression observed after a certain time. The same thicknesses of other liquids were then successively introduced, and the corresponding depressions noted. The difference of the depressions was a measure of the resistance which the liquid offered to the passage of heat.

The most complete researches on the conductivity of liquids are those of H. F. Weber, who made use of the following method. A copper disc about 8 cm. in radius was separated from another similar one by three pieces of glass, about 0.2 cm. thick. The space thus formed between the two was filled with the liquid to be examined, and the system placed horizontally on a smooth block of ice. The lower plate rapidly assumed the temperature of the ice, and heat travelled through the liquid from the upper plate, the changes in temperature of which were noted by a thermo-electric arrangement (418). He thus obtained the following values for k (411):—

Water	0.00124	Carbon bisulphide	0.00042
Solution of CuSO_4	0.00118	Ether	0.00040
Solution of NaCl	0.00115	Olive oil	0.00039
Glycerine	0.00067	Chloroform	0.00037
Alcohol	0.00049	Benzole	0.00032

Milner and Chattock (1899) found for the conductivity of water the value .00143 at 20°. Weber deduced from his researches that the diffusivity was the same for all the liquids examined by him.

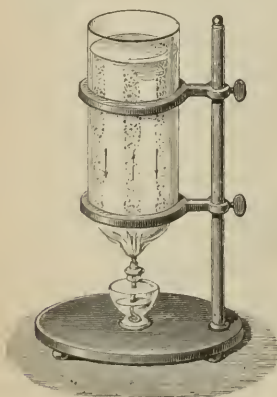

Fig. 395

414. **Manner in which liquids are heated.**—When a column of liquid is heated at the bottom, ascending and descending currents are produced. It is mainly by these that heat is distributed through the liquid, and not by its conductivity. These currents arise from the expansion of the inferior layers, which, becoming less dense, rise in the liquid, and are replaced by colder and denser layers. They may be made visible by projecting bran or wooden shavings into water, which rise and descend with the currents. The experiment is arranged as shown in fig. 395. The mode in which heat is thus propagated in liquids and in gases is said to be by *convection*.

415. **Conductivity of gases.**—It has been a disputed question whether gases have a true conductivity, that is to say, a conduction from layer to layer, as metals have; but certainly when they are

restrained in their motion their conductivity is very small. All substances, for instance, between whose particles air remains stationary, offer great resistance to the propagation of heat. This is well seen in straw, eider-down, and furs. The propagation of heat in a gaseous mass is effected by means of the ascending and descending currents formed in it, as is the case with liquids.

The following experiment, a modification of one originally devised by the late Sir W. Grove, is considered to prove that gases have a certain conductivity.

A glass tube (fig. 396) with two lateral tubes *d* and *e* opening into it at one end, is closed in the middle by a cork, *b*, through which a stout copper



Fig. 396

wire passes. This is connected by thin platinum wires with similar stout copper wires passing through the corks *a* and *c*. When a sufficiently strong electric current is passed through the wires, both platinum wires are equally incandescent. If, now, one half of the tube is filled with hydrogen by connecting one of the small tubes with a supply of that gas, and the current is again passed, the wire in the hydrogen is scarcely luminous, while that in air is still brightly incandescent.

This greater chilling of the wire in hydrogen than in air was considered by Magnus to be an effect of conduction; while Tyndall ascribed it to the greater mobility of the particles of hydrogen.

Stefan found the value of *k* for air to be 0.0000558 in C.G.S. units. He also found that hydrogen conducts seven times as well as air, and that difference of density seems to have no influence on the conductivity.

Maxwell deduced from purely theoretical considerations, based on the kinetic theory of gases, that the conductivity of air must be $\frac{1}{35.66}$ that of iron. Stefan's value is in fair agreement with this.

416. Applications.—The greater or less conductivity of bodies meets with numerous applications. If a liquid is to be kept warm for a long time, it is placed in a vessel and packed round with non-conducting substances, such as shavings, straw, or bruised charcoal. For this purpose water-pipes and pumps are wrapped in straw at the approach of frost. The same means are used to hinder a body from becoming heated. Ice is transported in summer by packing it in bran or folding it in flannel.

Double walls constructed of thick planks having between them any finely divided materials, such as shavings, sawdust, dry leaves, &c., retain heat extremely well; and are likewise advantageous in hot countries, for they prevent its access. Pure silica in the state of rock crystal is a better conductor than lead, but in a state of powder it conducts very badly. If a layer of asbestos is placed on the hand, a red-hot iron ball can be held without inconvenience. Red-hot cannon-balls can be wheeled to the gun's mouth in wooden barrows partially filled with sand. Lava has been known to flow

over a layer of ashes underneath which was a bed of ice, and the non-conducting power of the ashes has prevented the ice from melting.

The clothes which we wear are not warm in themselves; they only hinder the body from losing heat, in consequence of their spongy texture and the air they enclose. The warmth of bed-covers and of counterpanes is explained in a similar manner. Double windows are frequently used in cold climates to keep a room warm—they do this by the non-conducting layer of air interposed between them. It is for the same reason that two shirts are warmer than one of the same material but of double the thickness. Hence, too, the warmth of furs, eider-down, &c.

The small conducting power of felt is used in the North of Europe in the construction of the *Norwegian stove*, which consists merely of a wooden box with a thick lining of felt on the inside. In the centre is a cavity in which can be placed a stew-pan provided with a cover. On the top of this is a lid, also made of felt, so that the pan is surrounded by a very badly conducting envelope. Meat, with water and suitable additions, is placed in the pan, and the contents are then raised to boiling point. The whole is then enclosed in the box and left to itself; the cooking will go on without fire, and after the lapse of several hours it will be quite finished. The cooling down is very slow, owing to the bad conducting power of the lining; at the end of three hours the temperature is usually not found to have sunk more than from 10° to 15° .

A glass tumbler with thick bottom is liable to crack when boiling water is poured into it. The part on which the water falls is heated, and expands before the heat can penetrate far. A state of strain is thus produced which may be sufficient to break the glass.

That water boils more rapidly in a metallic vessel than in one of porcelain of the same thickness; that a burning piece of wood can be held close to the burning part with the naked hand, while a piece of iron heated at one end can only be held at a great distance, are easily explained by reference to their various conductivities.

The sensation of heat or cold which we feel when in contact with certain bodies is materially influenced by their conductivity. If we touch in succession a piece of iron and a piece of wood, both at the same temperature and colder than the hand, heat passes from the hand more rapidly to the iron (owing to its good conductivity) than to the wood; hence the iron feels the colder. If the iron and wood are at the same temperature which is higher than that of the hand, the iron feels the hotter, because the hand receives heat more rapidly from it than from the wood. Hence it is clear why carpets, for example, are warmer than wooden floors, and why the latter again are warmer than stone floors.

The closer the contact of the hand with a substance, the greater is the difference of temperature felt. With smooth surfaces there are more points of contact than with rough ones. A hot glass rod feels hotter than a piece of rusted iron of the same temperature, although the latter is a better conductor. The closer the substance is pressed, the more intimate the contact; an ignited piece of charcoal can be lifted by the fingers if it is not closely pressed.

CHAPTER VIII

RADIATION OF HEAT

417. **Radiant heat.**—It has been already stated (409) that heat can be transmitted from one body to another without altering the temperature of the intervening medium. If we stand in front of a fire we experience a sensation of warmth which is not due to the temperature of the air, for if a screen is interposed the sensation immediately disappears, which would not be the case if the surrounding air had a high temperature. Hence bodies can send out rays which excite heat, and which penetrate through the air without heating it, as rays of light through transparent bodies. Heat thus propagated is said to be *radiated*; and we shall use the terms *ray of heat*, or *thermal*, or *calorific ray*, in a similar sense to that in which we use the term *ray of light*, or *luminous ray*.

We shall find that the property of radiating heat is not confined to luminous bodies, such as a fire or a red-hot ball, but that bodies of all temperatures radiate heat. It will be convenient to make a distinction between *luminous* and *obscure* rays of heat.

418. **Detection and measurement of radiant heat.**—In demonstrating the phenomena of radiant heat, very delicate thermometers are required, and the thermo-electric multiplier of Melloni is used for this purpose with great advantage; for it not only indicates minute differences of temperature, but it also measures them with accuracy.

This instrument cannot be properly understood without a knowledge of the principles of thermo-electricity, for which Book X. must be consulted. It may, however, be stated here that when two different metals A and B are soldered together at one end (figs. 397, 398), the free ends being joined by a wire, when the junction C is heated, a current of electricity circulates through the system; if, on the contrary, the junction be cooled, a current is also produced, but it circulates in exactly the opposite direction.

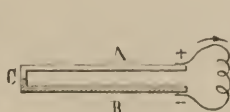

Fig. 397

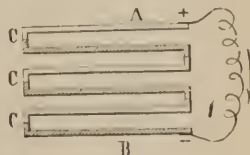

Fig. 398

This is called a *thermo-electric couple* or *pair*. If a number of such pairs be alternately soldered together, as represented in fig. 398, the strength of the current produced by heating the ends is increased; or, what amounts to the same thing, a smaller quantity of heat will produce the same effect. Such an

arrangement of a number of thermo-electric pairs is called a *thermo-electric battery* or *thermopile*.

Melloni's thermomultiplier consists of a thermopile connected with a delicate galvanometer. The thermopile is constructed of a number of thin bars of bismuth and antimony soldered together alternately, though kept insulated from each other, and contained in a rectangular box P (fig. 399). The terminal bars are connected with two binding screws, *m* and *n*, which in turn are connected with the galvanometer G by means of the wires *a* and *b*.

The galvanometer consists of a quantity of fine insulated copper wire coiled round a frame, in the centre of which a delicate magnetic needle is suspended by means of a silk thread. When an electric current is passed through this coil, the needle is deflected through an angle which depends on the strength of the current. The angle is measured on a dial by an index connected with the needle.

It may then be sufficient to state that the thermo-electric pile being connected with the galvanometer by means of the wires *a* and *b*, an excess of

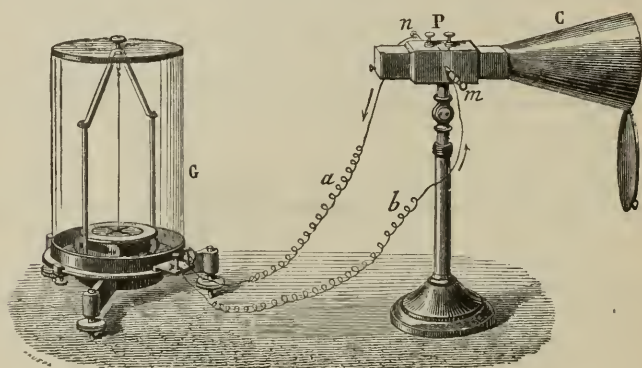

Fig. 399

temperature at one end of the pile causes the needle to be deflected through an angle which depends on the extent of this excess; and similarly, if the temperature is depressed below that of the other end, a corresponding deflection is produced in the opposite direction. With an instrument of this kind Melloni was able to measure differences of temperature of $\frac{1}{8000}$ th of a degree. The object of the cone C is to concentrate the thermal rays on the face of the pile.

The above was the apparatus used by Melloni in his classical experiments on radiant heat. More sensitive apparatus is available at the present day. For example, C. V. Boys' radio-micrometer (873) enables differences of temperature of one-millionth of a degree Centigrade to be detected.

419. **Laws of radiation.**—The following laws apply to the radiation of heat :—

1. *Radiation takes place in all directions from a body.* If a thermometer be placed in different positions round a heated body, it indicates everywhere a rise in temperature.

II. In a homogeneous medium radiation takes place in a right line. For, if a screen be placed in the right line which joins the source of heat and the thermometer, the latter is not affected.

But in passing obliquely from one medium into another, as from air into glass, thermal rays are deviated like luminous rays, an effect known as *refraction*. The laws of this phenomenon are the same for heat as for light, and they will be more fully discussed under the latter subject.

III. *Radiant heat is propagated in vacuo as well as in air.* This is demonstrated by the following experiment:—

In the bottom of a glass flask a thermometer is fixed in such a manner that its bulb occupies the centre of the flask (fig. 400). The neck of the flask is carefully narrowed by means of the blowpipe, and then the apparatus having been suitably attached to an air-pump, the flask is exhausted as far as possible. This having been done, the tube is sealed at the narrow part. On immersing this apparatus in hot water, or on bringing near it some hot charcoal, the thermometer is at once seen to rise. This could only be due to radiation through the vacuum in the interior, for glass is so bad a conductor that the heat could not travel with this rapidity through the sides of the flask and the stem of the thermometer.



Fig. 400

420. **Causes which modify the intensity of radiant heat.**—By the *intensity of radiant heat* at a particular place is understood the quantity of heat received on the unit of surface at that place. Three causes are found to modify this intensity: the temperature of the source of heat, its distance, and the obliquity of the calorific rays in reference to the surface which emits them. The laws which regulate these modifications may be thus stated:—

I. *The intensity of radiant heat is proportional to the temperature of the source.*

II. *The intensity is inversely as the square of the distance from the source.*

III. *The intensity is less, the greater the obliquity of the rays with respect to the radiating surface.*

The first law is demonstrated by placing a metal box containing water at 10° , 20° , or 30° successively at equal distances from the bulb of a differential thermometer. The temperatures indicated by the latter are then found to be in the same ratio as those of the box: for instance, if the temperature of that corresponding to the box at 10° be 2° , those of others will be 4° and 6° respectively.

The truth of the second law follows from the geometrical principle that the surface of a sphere increases as the square of its radius. Suppose a hollow sphere *ab* (fig. 401) of any given radius and a source of heat, *C*, in its centre; each unit of surface in the interior receives a certain quantity of heat. Now a sphere, *ef*, of double the radius will present a surface four times as great; its internal surface contains, therefore, four times as many

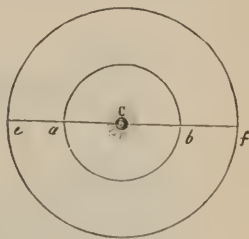

Fig. 401

units of surface, and as the quantity of heat emitted is the same, each unit must receive one-fourth the quantity.

To demonstrate the same law experimentally, a narrow tin-plate box is taken (fig. 402), filled with hot water, and coated on one side with lampblack. The thermopile with its conical cap, which in this experiment is lined with

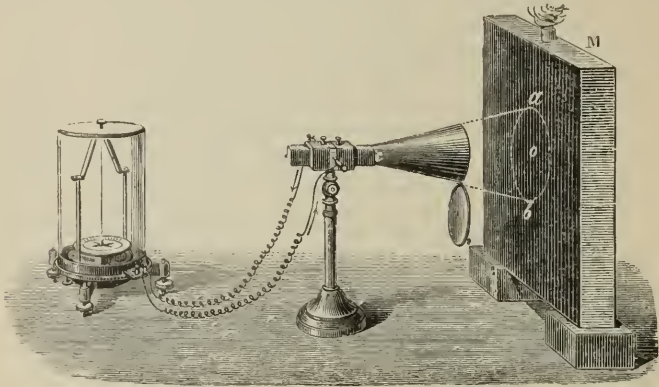

Fig. 402

black paper to absorb any radiation that falls upon it, is placed so that its face is at a certain definite distance, co , say 9 inches, from this box, and the cover having been lowered, the needle of the galvanometer is observed to be deflected through 80° for example.

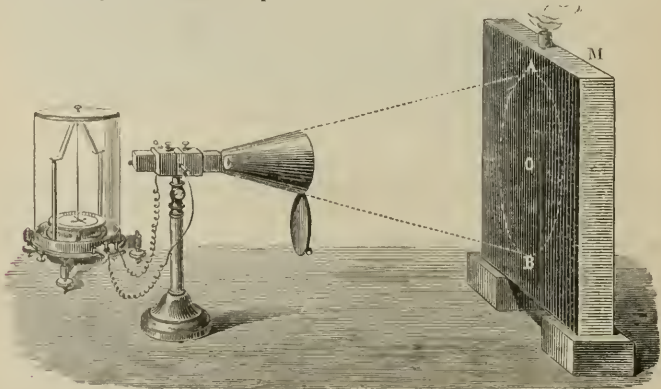

Fig. 403

If now the pile is removed to a distance, CO (fig. 403), double that of co , the deflection of the galvanometer is unaltered, which shows that the pile receives the same amount of heat as before; the constancy of the deflection is maintained when the pile is removed to three or four times the distance. This result, though apparently in opposition to the second law, really confirms it. For at first the pile only receives heat from the circular portion ab of the

side of the box, while, in the second case, the circular portion AB radiates towards it. But, as the two cones ACB and *acb* are similar, and the height of ACB is double that of *acb*, the diameter AB is double that of *ab*, and therefore the area AB is four times as great as that of *ab*, for the areas of circles are proportional to the squares of the radii. But since the radiating surface increases as the square of the distance, while the galvanometer remains stationary, the heat received by the battery must be inversely as this same square.

The third law is demonstrated by means of the following experiment, which is a modification of one originally devised by Leslie (fig. 404):—P represents the thermopile which is connected with its galvanometer, and A a metal cube full of hot water. The cube being first placed in such a

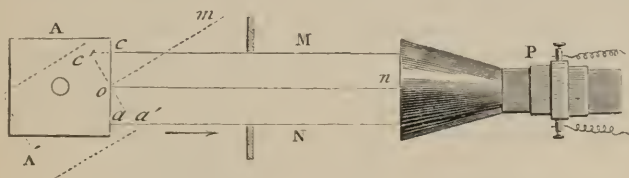

Fig. 404

position, A, that its front face, *ac*, is vertical, the deflection of the galvanometer is noted. Supposing it amounts to 45° , this represents the radiation from *ac*. If this now be turned in the direction represented by *A'*, the galvanometer is still found to mark 45° .

The second surface is larger than the first, and it therefore sends more rays to the mirror. But as the action on the thermometer is no greater than in the first case, it follows that in the second case, where the rays are oblique to the radiating surface, the intensity is less than in the first case, where they are perpendicular.

In order to express this in a formula, let *i* be the intensity of the rays emitted perpendicularly to the surface, and *i'* that of the oblique rays. These intensities are necessarily inversely as the surfaces *ac* and *a'c'*, for the effect is the same in both cases, and therefore $i' \times \text{surface } a'c' = i \times \text{surface } ac$; hence $i' = i \frac{\text{surf. } ac}{\text{surf. } a'c'} = i' \frac{ac}{a'c'} = i \cos. \alpha\alpha'$; which signifies that *the intensity of oblique rays is proportional to the cosine of the angle which these rays form with the normal to the surface*; for this angle is equal to the angle $\alpha\alpha'$. This law is known as the *law of the cosine*; it is, however, not general; Desains and De la Provostaye have shown that it is only true within very narrow limits; that is, only with bodies which, like lampblack, are entirely destitute of reflecting power (427).

421. **Mobile equilibrium. Theory of exchanges.**—Prévost of Geneva suggested the following hypothesis in reference to radiant heat, known as Prévost's *theory of exchanges*, which is now universally admitted. All bodies, whatever their temperatures, constantly radiate heat in all directions. If we imagine two bodies at different temperatures placed near each other, the one at a higher temperature will experience a loss of heat, its temperature will sink, because the radiation it emits is greater than that which it

receives ; the colder body, on the contrary, will rise in temperature, because it receives more radiation than it emits. Ultimately the temperature of both bodies becomes the same, but heat is still exchanged between them, only each receives as much as it emits, and the temperature remains constant. This state is called the *mobile equilibrium of temperature*.

422. **Newton's law of cooling.**—A body placed in a vacuum is only cooled or heated by radiation. In the atmosphere it becomes cooled or heated by its contact with the air, according as the latter is colder or hotter than the radiating body. In both cases the velocity of cooling or of heating—that is, *the quantity of heat lost or gained in a second*—is greater according as the difference of temperature is greater.

Newton enunciated the following law in reference to the cooling or heating of a body :—*The quantity of heat lost or gained by a body in a second is proportional to the difference between its temperature and that of the surrounding medium.* Dulong and Petit have proved that this law is not so general as Newton supposed, and only applies where the differences of temperature do not exceed 15° to 20° . Beyond that, the quantity of heat lost or gained is greater than what is required by this law.

According to Stefan, the radiation from a body varies as the fourth power of its absolute temperature (337). Recent determinations are in close agreement with this formula.

Two consequences follow from Newton's law :—

I. When a body is exposed to a constant source of heat, its temperature does not increase indefinitely, for the quantity which it receives in the same time is always the same ; while that which it loses increases with the excess of its temperature over that of the surrounding medium. Consequently a point is reached at which the quantity of heat emitted is equal to that absorbed, and the temperature then remains stationary.

II. Newton's law, as applied to the differential thermometer, shows that its indications are proportional to the quantities of heat which it receives. If one of the bulbs of a differential thermometer receives rays of heat from a constant source, the instrument exhibits, first, increasing temperature, but this afterwards becomes stationary. In this case the quantity of heat which it receives is equal to that which it emits. But the latter is proportional to the excess of the temperature of the bulb above that of the surrounding atmosphere—that is, to the number of degrees indicated by the thermometer, consequently the temperature indicated by the differential thermometer is proportional to the quantity of heat it receives.

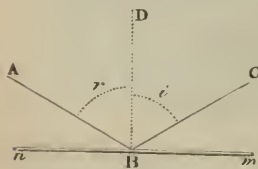

Fig. 405.

REFLECTION OF HEAT

423. **Laws of reflection.**—When thermal rays fall upon a body they are, speaking generally, divided into two portions, one of which penetrates the body while the other rebounds as if repelled from the surface like an elastic ball. This is said to be *reflected*.

If *mn* is a plane reflecting surface (fig. 405), *CB* an *incident ray*, *DB* a line perpendicular to the surface called the *normal*, and *BA* the *reflected*

ray, the angle CBD is called the *angle of incidence*, and DBA the *angle of reflection*. The reflection of heat, like that of light, is governed by the two following laws :—

I. *The angle of reflection is equal to the angle of incidence.*

II. *Both the incident and the reflected ray are in the same plane with the perpendicular to the reflecting surface.*

424. **Experimental demonstration of the laws of reflection of heat.**—

This may be effected by means of Melloni's thermopile and also by the conjugate mirrors (425). Fig. 406 represents the arrangement adopted in the former case. MN is a horizontal bar, about a metre in length, graduated in millimetres, on which slide various parts, which can be clamped by means of screws. The source of heat, S, is a platinum spiral, kept at a white heat in a spirit lamp. A screen K, when raised, cuts off the radiation from the source ; a second screen, F, with an aperture in the centre, cuts off all rays except a pencil which falls upon the mirror *m*. At the other end is an upright rod, I, with a graduated dial, the zero of which is in the direction of MN, and therefore parallel to the pencil *Sm*. In the centre of the dial is an aperture

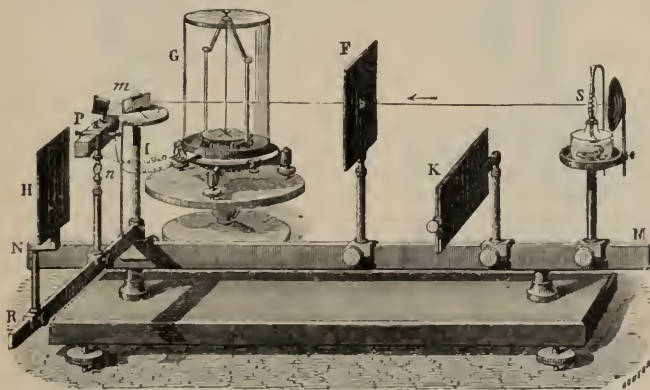

Fig. 406

in which turns an axis that supports a metallic mirror *m*. About this axis turns an arm, R, on which is fixed the thermopile, P, in connection with the galvanometer G. H is a screen, the object of which is to cut off any direct radiation from the source of heat towards the pile ; in order not to mask the thermopile, it is not represented in the position it occupies in the experiment.

By lowering the screen K, a pencil of parallel rays, passing through the aperture F, falls upon the mirror *m*, and is there reflected. If the arm R is not in the direction of the reflected pencil, this latter does not fall on the pile, and the needle of the galvanometer remains stationary ; but by slowly turning the arm R, a position is found at which the galvanometer attains its greatest deviation, which is the case when the pile receives the reflected pencil perpendicularly to its surface. Reading off then on the dial the position of a small needle perpendicular to the mirror, we observe that this bisects the angle formed by the incident and the reflected pencils, which demonstrates the first law.

The second law is also proved by the same experiment, for the various pieces of the apparatus are arranged so that the incident and reflected rays are in the same horizontal plane, and therefore at right angles to the reflecting surface, which is vertical.

425. **Verification of the laws of reflection.**—The following experiment, which was made for the first time by Pictet and Saussure, and which is known as the *experiment of the conjugate mirrors*, demonstrates not only the existence of the foci, but also the laws of reflection. Two concave spherical reflectors, M and N (fig. 407), are arranged at a distance of 4 to 5 yards, and so that their axes coincide. In the focus of one of them, A (see Light, ch. ii.), is placed a small wire basket containing a red-hot iron ball. In the focus of the other is placed B, an easily inflammable body, such as gun-cotton or phosphorus. The rays emitted from the focus A are first reflected from the mirror, M, in a direction parallel to the axis, and falling on the other mirror,

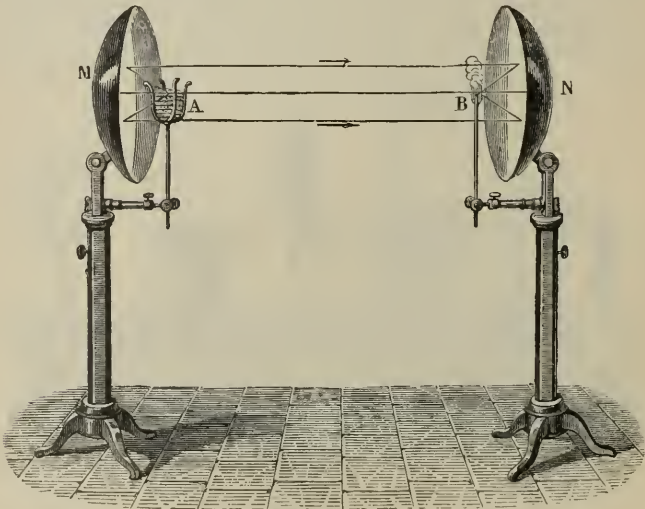

Fig. 407

N, are reflected so that they coincide in the focus B. That this is so, is proved by the fact that the gun-cotton at this point takes fire, which is not the case if it is above or below it. The experiment also serves to show that light and heat are reflected in the same manner.

If the hot ball is replaced by a small beaker containing a freezing mixture of ice and salt, and a thermopile is adjusted at the focus of N, with its face turned towards the mirror, the deflection of the galvanometer needle indicates a cooling of the pile. It would appear that as the hot ball radiated heat, the freezing mixture is radiating cold. But this would be an incorrect way of stating the case. Prévost's theory explains the phenomenon; both freezing mixture and thermopile are radiating heat, but the former radiates much less than it receives, while the latter receives much less than it radiates, and therefore is cooled.

The sensation of cold experienced when we stand near a stone wall whose temperature is lower than our body, or when we stand in front of a wall of ice, is explained in the same way.

From the high temperature produced in the foci of concave mirrors they have been called *burning mirrors*. It is stated that Archimedes burnt the Roman vessels before Syracuse by means of such mirrors. Buffon constructed burning mirrors of such power as to prove that the feat attributed to Archimedes was not impossible. The mirrors were made up of a number of silver plane mirrors about 8 inches long by 5 broad. They could be turned independently of each other in such a manner that the rays reflected from each coincided in the same point. With 128 mirrors and a hot summer's sun Buffon ignited a plank of tarred wood at a distance of 70 yards.

426. **Reflection in a vacuum.**—Heat is reflected in a vacuum as well as in air, as is seen from the following experiment (fig. 408), due to Sir Humphry Davy. Two small concave reflectors were placed opposite each other under the receiver of an air-pump. In the focus of one was placed a delicate thermometer, and in the focus of the other a platinum wire made incandescent by means of an electric current. The thermometer was immediately seen to rise several degrees, which could only be due to reflected heat, for the thermometer did not show any increase of temperature if it were not exactly in the focus of the second reflector.

427. **Reflecting power.**—The *reflecting power* of a substance is its property of throwing off a greater or lesser proportion of incident heat.

This power varies in different substances. In order to study this power in different bodies without having recourse to as many reflectors, Leslie arranged his experiment as shown in fig. 409. The source of heat is a cubical canister, M, now known as *Leslie's cube*, filled with hot water. A plate, *a*, of the substance to be experimented upon is placed on the axis of a concave mirror near the principal focus. In this manner the rays emitted by the source are first reflected from the concave mirror and impinge on the plate *a*, where they are again reflected and converge to the focus between the plate and the mirror, at which point a differential thermometer is placed. The reflector and the thermometer are always in the same position, and the water of the cube is always kept at 100° , but it is found that the temperature indicated by the thermometer varies with the nature of the plate. This method gives a means of determining, not the absolute reflecting power of a body, but its power relatively to that of some body taken as a standard of comparison. For from what has been said on the application of Newton's law to the differential thermometer (422), the temperatures which this instrument indicates are proportional to the quantities of heat which it receives. Hence,

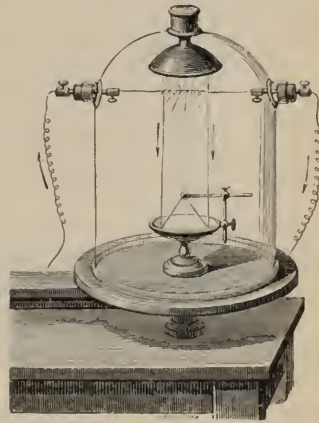

Fig. 408

if in the above experiment a plate of glass causes the temperature to rise 1° and a plate of lead 6° , it follows that the quantity of heat reflected by the latter is six times as great as that reflected by the former. For the heat emitted by the source remains the same, the concave reflector receives the same portion, and the difference can only arise from the reflecting power of the plate α .

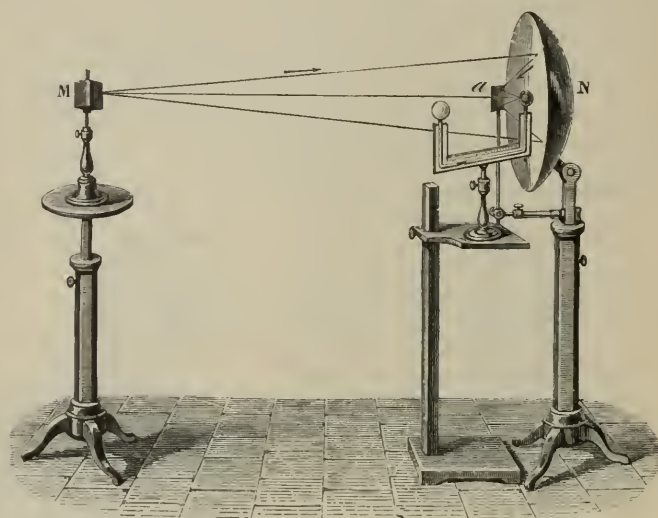

Fig. 409

By this method Leslie determined the reflecting powers of the following substances, relatively to that of brass, taken as 100 :—

Polished brass	100	Indian ink	13
Silver	90	Glass	10
Steel	70	Oiled glass	5
Lead	60	Lampblack	0

The numbers only represent the relative reflecting powers. Their absolute power is the relation of the quantity of heat reflected to the quantity of heat received. Desains and De la Provostaye obtained the following results for the absolute reflecting power by means of Melloni's thermopile (418), the heat being reflected at an angle of 50° :—

Silver plate	0.97	Steel	0.82
Gold	0.95	Zinc	0.81
Brass	0.93	Iron	0.77
Platinum	0.83	Cast iron	0.74

428. **Absorbing power.**—The *absorbing power* of a body is its property of allowing a greater or less quantity of the heat which falls upon it to pass into its mass. Its absolute value is the ratio of the quantity of heat absorbed to the quantity of heat received.

The absorbing power of a body is always inversely as its reflecting power : a body which is a good absorbent is a bad reflector, and *vice versa*. It was formerly supposed that the two powers were exactly complementary, that the sum of the reflected and absorbed heat was equal to the total quantity of incident heat. This is not the case ; it is always less : the incident heat is divided into three parts—1st, one which is absorbed ; 2nd, another which is reflected regularly, that is, according to laws previously demonstrated (423) ; and a third, which is irregularly reflected in all directions, and which is called *scattered* or *diffused heat*. A part of the heat also may pass through the substance, as light passes through glass.

In order to determine the absorbing power of bodies, Leslie used the apparatus which he employed in determining the reflecting powers (427). But he suppressed the plate *a*, and placed the bulb of the thermometer in the focus of the reflector. This bulb being then covered successively with lampblack, or varnish, or with gold, silver, or copper foil, &c., the thermometer exhibited a higher temperature under the influence of the source of heat, *M*, according as the substance with which the bulb was covered absorbed more heat. Leslie found in this way that the absorbing power of a body is greater the less its reflecting power. In these experiments, however, the relation of the absorbing powers cannot be deduced from that of the temperatures indicated by the thermometer, for Newton's law is not exactly applicable in this case, as it only prevails for bodies whose substance does not vary, and here the covering of the bulb varied with each observation. But we shall presently show (430) how the comparative absorbing powers may be deduced from the ratios of the emissive powers.

Taking, as a source of heat, a canister filled with water at 100°, Melloni found, by means of the thermopile, the following relative absorbing powers :—

Lampblack	100	Indian ink	85
White lead	100	Shellac	72
Isinglass	91	Metals	13

429. **Radiating power.**—The *radiating* or *emissive power* of a body is its capability of emitting, at the same temperature, and with the same extent of surface, greater or less quantities of heat.

The apparatus represented in fig. 409 was also used by Leslie in determining the radiating power of bodies. For this purpose the bulb of the thermometer was placed in the focus of the reflector, and the faces of the canister *M* were formed of different metals, or covered with different substances such as lampblack, paper, &c. The cube being filled with hot water, at 100°, and all other conditions remaining the same, Leslie turned each face of the cube successively towards the reflectors, and noted the temperature each time. That face which was coated with lampblack caused the greatest elevation of temperature, and the metal faces the least. Applying Newton's law, Leslie found the following table of radiating powers :—

Lampblack	100	Tarnished lead	45
White lead	100	Mercury	20
Paper	98	Polished lead	19
Ordinary white glass	90	Polished iron	15
Isinglass	80	Tin, gold, silver, copper, &c.	12

It will be seen that, in this table, the order of the bodies is exactly the reverse of that in the tables of reflecting powers.

The radiating powers of several substances were determined by Desains and De la Provostaye, who used the thermopile. They found, in this manner, the following numbers compared with lampblack as 100 :—

Platinum foil	10·80
Burnished platinum	9·50
Silver deposited chemically	5·36
Copper foil	4·90
Gold leaf	4·28
Pure silver laminated	3·00
„ deposited chemically and burnished	2·25

The radiating power found by Leslie for the metals is thus too large.

430. Identity of the absorbing and radiating powers.—The absorbing power of a body cannot be accurately deduced from its reflecting power, because the two are not exactly complementary. But the absorbing power would be determined if it could be shown that in the same body it is equal

to the radiating power. This conclusion has been drawn by Dulong and Petit from the following experiments:—In a large glass globe, blackened on the inside, was placed a thermometer at a certain temperature, 15° for example; the globe was kept at zero by means of ice, and after it had been exhausted by means of an air-pump, the time was noted which elapsed while the thermometer fell through 5° . The experiment was then made in the contrary direction; that is, the sides of the globe were heated to $1^{\circ}5$, while the thermometer was cooled to zero; the time was then observed which the thermometer occupied in rising through 5° . It was found that this time was exactly the same as that which the thermometer had taken in sinking through 5° , and it was thence concluded that the radiating power is equal to the absorbing power for the same body,

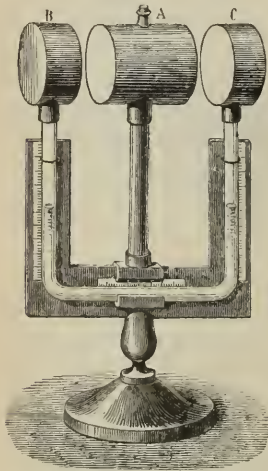

Fig. 410

and for the same difference between its temperature and the temperature of the surrounding medium, because the quantities of heat emitted or absorbed in the same time are equal.

This point may also be demonstrated by means of the following apparatus devised by Ritchie. Fig. 410 represents what is virtually a differential thermometer, the two glass bulbs of which are replaced by two cylindrical reservoirs B and C, of metal, and full of air. Between them is a third and larger one, A, which can be filled with hot water. The ends of B and of A, which face the right, are coated with lampblack; those of C and of A, which face the left, are either painted white, or are coated with silver foil. Thus one of the two faces opposite each other is black, and the other

white : hence when the cylinder A is filled with hot water, its white face radiates towards the black face of B, and its black face towards the white face of C. In these circumstances the liquid in the stem does not move, indicating that the two reservoirs are at the same temperature. On the one hand, the greater emissive power of the black face of A is compensated by the smaller absorptive power of the white face of C ; while, on the other hand, the feebler radiating power of the white face of A is compensated by the greater absorbing power of the black face of B.

The experiment may be varied by replacing the two white faces by discs of paper, glass, porcelain, &c.

431. **Causes which modify the reflecting, absorbing, and radiating powers.**—As the radiating and absorbing powers are equal, any cause which affects the one affects the other also. And as the reflecting power varies in an inverse manner, whatever increases it diminishes the radiating and absorbing powers, and *vice versa*.

It has been already stated that these different powers vary with different bodies, and that metals have the greatest reflecting power, and lampblack the least. In the same body these powers are modified by the degree of polish, the density, the thickness of the radiating substance, the obliquity of the incident or emitted rays, and lastly, by the nature of the source of heat.

It has been usually assumed that the reflecting power increases with the polish of the surface, and that the other powers diminish therewith. But Melloni showed that by scratching a polished metallic surface its reflecting power was sometimes diminished and sometimes increased. This phenomenon he attributed to the greater or less density of the reflecting surface. If the plate had been originally hammered, its homogeneity would be destroyed by this process, the molecules would be closer together on the surface than in the interior, and the reflecting power would be increased. But if the surface is scratched, the interior and less dense mass becomes exposed, and the reflecting power diminished. On the contrary, in a plate which has not been hammered, and which is homogeneous, the reflecting power is increased when the plate is scratched, because the density at the surface is increased by the scratches.

Melloni found that when the faces of a cube filled with water at a constant temperature were varnished, the emissive power increased with the number of layers up to 16 layers, while above that point it remained constant, whatever the number. The thickness of the 16 layers was calculated to be 0.04 mm. With reference to metals, gold leaves of 0.008, 0.004, and 0.002 of a millimetre in thickness, having been successively applied on the sides of a cube of glass, the diminution of radiant heat was the same in each case. It appears, therefore, that, beyond certain limits, the thickness of the radiating layer of metal is without influence.

The absorbing power is greatest when the rays are at right angles to the surface, and it diminishes in proportion as the incident rays deviate from the normal. This is one reason why the sun is hotter in summer than in winter, because, in the former case, the sun's rays are less oblique.

The radiating power of gaseous bodies in a state of combustion is very weak, as is seen by bringing the bulb of a thermometer near a hydrogen flame, the temperature of which is very high. But if a platinum spiral is

placed in this flame, it assumes the temperature of the flame, and radiates a great amount of heat, as is shown by the thermometer. For a similar reason the flames of oil and of gas lamps radiate more than a hydrogen flame in consequence of the excess of carbon which they contain, and which, not being entirely burned, becomes incandescent in the flame.

432. **Melloni's researches on radiant heat.**—For our knowledge of the phenomena of the reflection, emission, and absorption of heat which have up



FIG. 411



Fig. 412



Fig. 413

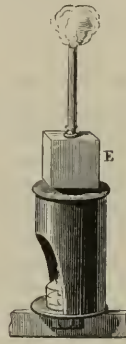

Fig. 414

to now been described, science is indebted mainly to Leslie. But since his time the discovery of other and far more delicate modes of detecting and measuring heat has not only extended and corrected our previous know-

ledge, but has led to the discovery of other phenomena of radiant heat, which without such improved means must have remained unknown.

This advance in science is due to an Italian philosopher, Melloni, who first applied the thermopile, invented by Nobili, to the measurement of very small differences of temperature: a method of which a preliminary account has already been given (418).

In his experiments Melloni used five sources of heat—1st, a Locatelli's lamp—one, that is, without a glass chimney, but provided with a reflector (fig. 411); 2nd, an Argand lamp, that is, one with a chimney and a double draught; 3rd, a platinum spiral, kept red-hot by a spirit lamp (fig. 412); 4th, a blackened copper plate, kept at a temperature of about 400° by a spirit lamp (fig. 413); 5th, a copper tube, blackened on the outside and filled with water at 100° (fig. 414).

433. **Dynamical theory of heat.**—Before describing the results arrived at by various investigators, it will be convenient to explain here the view now generally taken as to the nature of heat and the mode in which it is propagated. For additional information the chapter on the Mechanical Theory of Heat and the Book on Light should be read. We must regard a hot body as nothing more than one whose particles are in a state of vibration. The higher the temperature of the body, the more rapid are these vibrations, and a diminution in temperature is but a diminished rapidity of vibration of the particles. The propagation of heat through a bar is due to a gradual communication of this vibratory motion from the heated part to the rest of the bar. A good conductor is one which readily takes up and transmits the vibratory motion from particle to particle, while a bad conductor is one which takes up and transmits the motion with difficulty. But even through the best conductors the propagation of this motion is comparatively slow. How then are

we to explain the instantaneous perception of heat experienced when a screen is removed from a fire, or when a cloud drifts from the face of the sun? In this case the heat passes from one body to another without affecting the temperature of the space through which it passes. In order to explain these phenomena, it is imagined that all space, the interplanetary spaces as well as the interstices in the hardest crystal or the heaviest metal—in short, matter of any kind—is permeated by a medium having enormously great tenuity and elasticity, called *the ether* (510). The particles of a heated body, being in a state of intensely rapid vibration, communicate their motion to the ether around them, the particles of which are set in successive vibration, and hence give rise to waves in the ether, which travel through space and pass from one body to another with the velocity of light. When the undulations of the ether reach a given body, the motion is again delivered up to the particles of that body, which in turn begin to vibrate: that is, the body becomes heated. This process of motion through the hypothetical ether, starting from a given source, is termed radiation, and what is called a 'ray of heat' is merely a series of waves moving in a certain direction.

It will facilitate the understanding of this to consider the analogous mode in which sound is produced and propagated. A sounding body is one whose entire mass is in a state of vibration (223); the more rapid the rate of vibration, the more acute the sound; the slower the rate of vibration, the deeper the sound. This vibratory motion is communicated to the surrounding air, by means of which some of its energy of vibration reaches the auditory nerve, and there produces the sensation of sound. If a metal ball is heated, say, to the temperature of boiling water, we can ascertain that it radiates heat, although we cannot see any luminosity; and if its temperature is gradually raised, we see it becomes successively of a dull red, bright red, and dazzling white (336). At each particular temperature the heated body emits waves of a definite length; in other words, its particles vibrate in a certain period. As its temperature rises the radiation emitted is of shorter wave-length, corresponding to more rapid vibrations, which coexist, however, with all those which it had previously emitted. Thus the motion at each successive temperature is compounded of all preceding ones.

It has been seen that vibrations of the air below and above a certain rate do not affect the auditory nerve (244); it can only take up and transmit to the brain vibrations lying within a certain range of frequency. So too with the vibrations which produce light. The optic nerve is insensible to a large number of wave-lengths. It can apprehend only those waves that form the visible spectrum. If the rate of undulation is slower than the red or faster than the violet, though intense motion may pass through the humours of the eye and fall upon the retina, yet we shall be utterly unconscious of the fact, for the optic nerve cannot take up and respond to the vibrations which exist beyond the visible spectrum in both directions. Hence, these are termed *invisible* or *obscure* rays. A vast quantity of these obscure rays is emitted by flames which, though intensely hot, are yet almost non-luminous, such as the oxy-hydrogen flame, or that of a Bunsen's burner; for the vibrations which these emit, though capable in part of penetrating the media of the eye, are incapable of exciting in the optic nerve the sensation of light.

434. **Thermal analysis of sunlight.**—Let a narrow vertical slit be made in the shutter of a dark room and strongly illuminated by sunlight, and let the light from the slit be focused by a rock-salt lens on a screen, and a rock-salt prism be placed as shown in fig. 415. The light after emerging from the prism will be found to present on the screen a band of colours in the following order: red, orange, yellow, green, blue, and violet. This is called the *spectrum* (574).

If now a narrow and delicate thermopile (435) is placed successively on the space occupied by each of the colours, it will be comparatively little affected on the violet, but in passing over the other colours it will indicate a gradual rise of temperature, which is greatest at the red. Painters, thus guided by a correct but unconscious feeling, always speak of blue and green colours as cold, and of red and orange as warm tones. If the thermopile is gradually moved from a point beyond the violet through the visible spectrum to a point considerably beyond the red at the other end of the spectrum, a rise of temperature is indicated which attains a maximum value at the position P beyond the red. From this point the pile indicates a decrease of

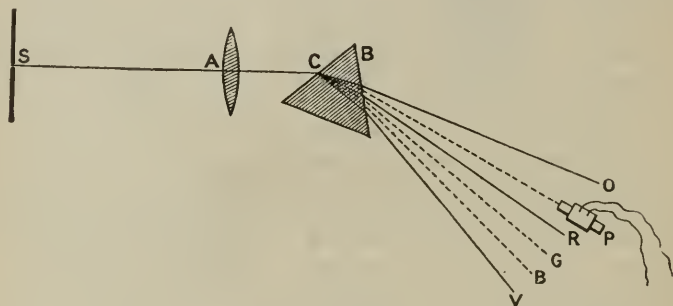

Fig. 415

temperature until it reaches a point, O, where it ceases to be affected. This point is about as distant from R as the latter is from V; that is, there is a region in which thermal effects are produced extending to a considerable distance beyond the red end of the spectrum. In accordance with what has been said, the radiation from the sun consists of rays of different rates of vibration. By their passage through the prism they are unequally broken or refracted; those of greatest wave-length or slowest vibrating period are least bent aside, or are said to be the least refrangible, while those with the shortest wave-lengths are the most refrangible.

We must regard the radiation from the sun as consisting of a vast assemblage of superposed waves of different wave-lengths. By the prism the compound waves are broken up into their constituents, the short waves being more refrangible than the longer ones. As stated in the last article, the eye is sensitive only to a small range of wave-lengths, from about $700 \mu\mu$ (dark red) to $350 \mu\mu$ (violet), viz. those in which the ether particles vibrate from 500 to 1000 billion times per second. The present chapter is chiefly occupied with the consideration of the long waves, those of the red end of the spectrum and the part beyond. Evidence of the existence of the

rays beyond the violet is obtained by their action on silver salts, on fluorescent substances, &c. But whatever the wave-length, the radiation, if it falls on a lampblack surface, is absorbed by it and converted into heat, the absorption thus measuring the energy of the incident radiation. The energy, measured in this way, is greatest at the red end and beyond, and we often speak of these rays as the *heat* rays of the spectrum, those in the visible part as the *light* rays, and those beyond the violet as the *actinic* rays. But it must be remembered that actinic action is not confined to rays of short wave-length, any more than thermal action is confined to the red rays; the green, red, and infra-red rays will all produce photographic action under proper conditions. Indeed, so far as we know, the only physical distinction between light rays, heat rays, and chemical rays is that of wave-length.

Radiation does not leave the sun either as light or heat, but as radiant energy. If the wave-length of the radiation lies between certain limits, and the rays fall on the eye, we call them *light*; but those same rays are capable of decomposing the silver bromide of a photographic plate, and are thus *actinic* rays; they will also raise the temperature of a blackened bulb thermometer, and therefore are *heat* rays.

If, in the above case, prisms of other materials than rock salt are used, the position of the maximum heat will be found to vary with the nature of the prism, a fact first noticed by Seebeck. Thus with a prism of water it is in the yellow, with one of crown glass in the middle of the red, and so on. These changes are due to the circumstance that prisms of different materials absorb rays of different refrangibility to unequal extents. But rock salt practically allows radiation of all kinds to pass with equal facility, and thus gives a normal spectrum.

435. **Tyndall's researches.**—Tyndall investigated the spectrum produced by the electric light by the following method:—The beam of electric light, rendered parallel by a rock-salt lens, was caused to pass through a narrow slit, and then through a second lens of rock salt; the slices of white light thus obtained being decomposed by a prism of the same material. To investigate the thermal conditions of the spectrum a *linear* thermo-electric pile was used; that is, one consisting of a number of elements arranged in a line, in front of which was a slit that could be narrowed to any extent. The instrument was mounted on a movable bar connected with a fine screw, so that by turning a handle the pile could be moved through the smallest space. On placing this apparatus successively in each part of the spectrum of the electric light, the heating effected at various points near each other was determined by a delicate galvanometer. As in the case of the solar spectrum, the heating effect gradually increased from the violet end towards the red, and was greatest in the dark space beyond the red. The position of the greatest heat was about as far from the limit of the visible red as the latter was from the green, and the total extent of the invisible spectrum was found to be twice that of the visible.

The increase of temperature in the dark space is very considerable. If thermal intensities—*i.e.* relative amounts of radiant energy absorbed by the thermopile—are represented by perpendicular lines of proportionate length,

erected at those parts of the spectrum to which they correspond, on passing beyond the red end these lines increase rapidly and greatly in length, reach a maximum, and then fall somewhat more suddenly. The ends of these lines lie on a curve (fig. 416), which beyond the red represents a peak, quite dwarfing that of the visible spectrum. The dark parts at the

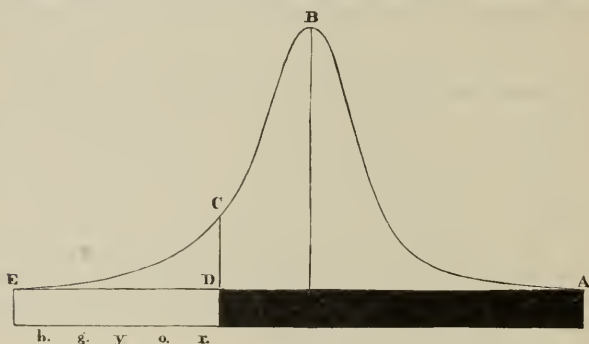

Fig. 416

end represent the obscure radiation. The curve is based, in the manner above stated, on the results obtained by Tyndall with the electric light. The upper curve in fig. 417 represents the spectrum of sunlight with a rock-salt prism, while the lower curve represents the results obtained with a



Fig. 417

flint-glass prism, which is thus seen to absorb some of the ultra-red radiation.

By interposing various substances, more especially water, in certain thicknesses, in the path of the electric light, the ultra-red radiation was greatly diminished. Now aqueous vapour, like water, absorbs the obscure rays. And probably the reason why the obscure part of the spectrum of sunlight is not so intense as in the case of the electric light is that the obscure rays have been already partially absorbed by the aqueous vapour of the atmosphere. If the solar spectrum could be examined outside the atmosphere, it would probably be found to be more like that of the electric light, which is unaffected by the atmospheric absorption.

This has been confirmed in other ways. Melloni observed that the

position of the maximum in the solar spectrum differs on different days ; which is probably due to the varying absorption of the atmosphere, in consequence of its varying hygrometric state. Secchi, in Rome, found the same shifting of the maximum to occur in the different seasons of the year ; for in winter, when there is least moisture in the atmosphere, the maximum is farther from the red than in summer, when the aqueous vapour in the air is most abundant. Cooke found that the faint black lines in the solar spectrum attributed to the absorption of light by our atmosphere (see Book on Optics) are chiefly caused by the presence of aqueous vapour.

436. **Langley's observations.**—The most accurate and complete investigations of the energy spectrum of the sun are those made by Langley ; he used for this purpose a Rowland's grating (662) so as to avoid effects due to absorption, and the heat in the various parts in the spectrum thus produced was measured by a *bolometer* (932) which showed differences in temperature

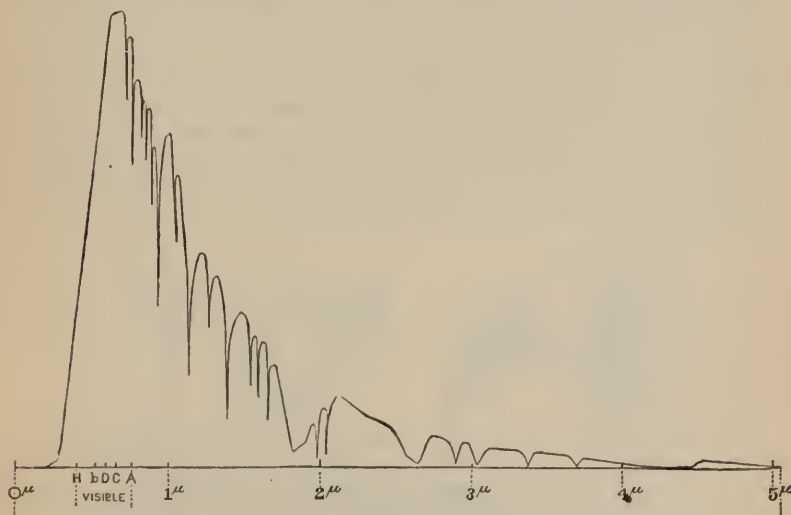

Fig. 418

of 0.00001° F. He obtained in this way a spectrum invisible to the eye extending beyond the red to 20 times the length of the visible spectrum. Fig. 418 represents about two-thirds of this length, extending to a wave-length of $5 \mu = 0.005$ mm. The absorption of the radiation by the bolometer begins to be measurable just outside the violet at a wave-length of about 0.25μ , and is at a maximum at a wave-length of 0.65μ . The depressions in the curve represent the dark lines, or what are called *Fraunhofer's lines* (585).

For details of the experiments and interpretation of the results the student should consult the original paper, *Phil. Mag.* [v] vol. 26, p. 505.

437. **Luminous and obscure radiation.**—The radiation from a luminous object, a gas flame, for example, is of a composite character ; a portion consists of what we term light, but a far greater part consists of heat rays, which are insensible to our eyes, being unable to affect the optic nerve.

When this mixed radiation falls upon the blackened face of a thermo-electric pile, the whole of it is taken to be absorbed, the light by this act being converted into heat, and affecting the instrument proportionally with the invisible rays. The total radiation of a luminous source, expressed in heat or energy units, can thus be measured. By introducing into the path of the rays a body capable of stopping either the luminous or the obscure radiation, we can ascertain by the comparative action on the pile the relative quantities of heat and light radiated from the source. Melloni sought to do this by passing a luminous beam through a layer of water containing alum in solution, a liquid which he found in previous experiments absorbed all the radiation from bodies heated under incandescence. Comparing the transmission through this liquid—which allowed the luminous but not the obscure part of the beam to pass—with the transmission through a plate of rock salt—which affected neither the luminous nor the obscure radiation, but gave the loss due to reflection—Melloni found that 90 per cent. of the radiation from an oil flame and 99 per cent. of the radiation from an alcohol flame consist of invisible calorific rays. Tyndall employed a solution of iodine in carbon bisulphide, which he found to be impervious to the brightest light, but very pervious to radiation of great wave-length; only a slight absorption being effected by the bisulphide. By comparing the transmission through the transparent bisulphide, and that through the same liquid rendered opaque by iodine, the value of the luminous radiation from various sources was found to be as follows:—

Source	Luminous	Obscure
Red-hot spiral	0	100
Hydrogen flame	0	100
Oil flame	3	97
Gas flame	4	96
White-hot spiral	4.6	95.4
Electric light	10	90

Here by direct experiment the ratio of luminous to obscure rays in the electric light is found to be 10 per cent. of the total radiation. By prismatic analysis, the curve shown in fig. 416 was obtained, graphically representing the proportion of luminous to obscure rays in the electric light; by calculating the areas of the two spaces in the diagram, the obscure portion, DCBA, is found to be nearly ten times as large as the luminous one, DCE.

438. **Transmutation of obscure rays.**—We shall find, in speaking of the luminous spectrum (575), that beyond the violet there are rays which are invisible to the eye, but which are distinguished by their chemical action, and are spoken of as the *actinic* or chemical rays; they are also known as the *Ritteric* rays, from the philosopher who first discovered their existence.

Stokes, as we shall afterwards see in the Book on Optics, succeeded in converting these rays into visible rays of lower refrangibility; so Tyndall effected the corresponding but inverse change, and increasing the refrangibility of the ultra-red rays, rendered them visible. The carbon points of the electric light were placed in front of a concave silvered glass mirror

so that the rays after reflection were concentrated to a focus about 6 inches distant. On the path of the beam was interposed a cell full of a solution of iodine in carbon bisulphide, which (437) has the power of completely stopping all luminous radiation, but gives free passage to the non-luminous rays. A piece of platinum placed in the focus of the beam, thus sifted, was raised to incandescence by the perfectly invisible rays. In like manner a piece of charcoal *in vacuo* was heated to redness.

By a proper arrangement of the carbon points a metal may be raised to whiteness, and the light now emitted by the metal yields on prismatic analysis a brilliant luminous spectrum, which is thus entirely derived from the invisible rays beyond the red. This transmutation of non-luminous into luminous heat Tyndall called *calorescence*.

When the eye was cautiously placed in the focus, guarded by a small hole pierced in a metal screen, so that the converged rays should only enter the pupil and not affect the surrounding part of the eye, no impression of light was produced, and there was scarcely any sensation of heat. A considerable portion was absorbed by the humours of the eye, but yet a powerful beam undoubtedly reached the retina; for, as Tyndall showed by a separate experiment, about 18 per cent. of the obscure radiation from the electric light passed through the humours of an ox's eye.

439. **Transmission of thermal rays.**—Melloni examined the absorption of heat by solids and liquids by the apparatus represented in fig. 419, where AB

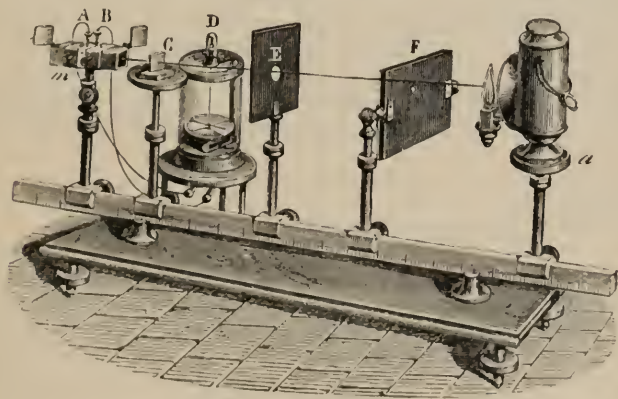

Fig. 419

is the thermopile; *a* is a support for the source of heat, in this case a Locatelli's lamp; F and E are screens, C is a support, and D the galvanometer.

To express the power which bodies have of transmitting heat, Melloni used the term *diathermancy*: diathermancy bears the same relation to radiant heat that transparency does to light; and in like manner the power of stopping radiant heat is called *athermancy*, which thus corresponds to

opacity for light. A diathermanous substance is one which allows incident radiation to pass through it, apart from any consideration of the wave-length of the radiation. A transparent substance transmits waves of medium length, and may or may not be opaque to the very long or very short waves. A substance may be absolutely opaque and yet allow the ultra-violet or the infra-red waves, or both, to pass. When heat rays are spoken of, it must be understood that infra-red rays are generally meant. In experimenting on the diathermancy of liquids, Melloni used glass troughs with parallel sides, the thickness of the liquid layer being 0.36 inch. The radiation of an Argand lamp was first allowed to fall directly on the face of the pile, and the deflection produced in the galvanometer taken as measuring the total radiation t' , the substance under examination was then interposed, and the deflection noted. This corresponded to the quantity of heat, t , which is transmitted by the substance. Hence

$$t' : t :: 100 : x$$

the percentage of rays transmitted. Thus calling the total radiation 100, Melloni found that

Carbon bisulphide transmitted	63
Olive oil	„	30
Ether	„	21
Sulphuric acid	„	17
Alcohol	„	15
Solution of alum or sugar	„	12
Distilled water	„	11

In experimenting with solids they were cut into plates 0.1 inch in thickness, and it was found that of every 100 rays there were transmitted by

Rock salt	92	Selenite	.	.	.	20
Smoky quartz	67	Alum	.	.	.	12
Transparent lead carbonate	52	Copper sulphate	.	.	.	0

The transmission of radiation through liquids was re-examined by Tyndall, who used a cell consisting of parallel plates of rock salt separated by a ring of brass with an aperture on the top through which the liquid could be poured. As this ring could be changed at will, liquid layers of various thicknesses were easily obtainable, the apparatus being merely screwed together and made liquid-tight by paper washers. The instrument was mounted on a support before an opening in a brass screen placed in front of the thermopile. The source of heat employed was a spiral of platinum wire raised to incandescence by an electric current, the spiral being enclosed in a small glass globe with an aperture in front, through which the radiation passed unchanged in its character, a point of essential importance overlooked by Melloni. The following table contains the results of experiments made with liquids in the various thicknesses indicated, the numbers expressing the *absorption* per cent. of the total radiation. The *transmission* per cent. can be found in each case by subtracting the absorption from 100. Thus a

layer of water 0.2 inch thick absorbs 80.7 and transmits 19.3 per cent. of the radiation from a red-hot spiral.

Absorption of heat by liquids

Liquid	Thickness of liquids in parts of an inch				
	0.02	0.04	0.07	0.14	0.27
Carbon bisulphide	5.5	8.4	12.5	15.2	17.3
Chloroform	16.6	25.0	35.0	40.0	44.8
Methyl iodide	36.1	46.5	53.2	65.2	68.6
Benzole	43.4	55.7	62.5	71.5	73.6
Amylene	58.3	65.2	73.6	77.7	82.3
Ether	63.3	73.5	76.1	78.6	85.2
Alcohol	67.3	78.6	83.6	85.3	89.1
Water	80.7	86.1	88.8	91.0	91.0

It thus appears that there is no connection between diathermancy and transparency. These liquids, which are all colourless and transparent, vary as much as 75 per cent. in the amount of heat transmitted. Smoky quartz, which is nearly opaque to light, transmits heat very well; while alum, which is perfectly transparent, cuts off 88 per cent. of heat rays. As there are different degrees of transparency, so there are different degrees of diathermancy; and the one cannot be predicated from the other.

440. **Influence of the nature of the source of heat.**—The diathermanous power differs greatly with the radiation from different sources, as is seen from the following table, in which the numbers express what proportion of every 100 rays from the different sources of heat incident on the plates is transmitted:—

Transmission of radiation

	Locatelli's lamp	Incandescent platinum wire	Copper at 400°	Copper at 100°
Rock salt	92	92	92	92
Fluor spar	78	69	42	33
Plate glass	39	24	6	0
Black glass	26	55	12	0
Selenite	14	5	0	0
Alum	9	2	0	0
Ice	6	0.5	0	0

Rock salt is here stated to transmit all kinds of heat with equal facility, and to be the only substance which does so. It is analogous to white glass, which is transparent for light from all sources. Fluor spar transmits 78 per cent. of the rays from a lamp, but only 33 of those from a blackened surface at 100°. A piece of plate glass only one-tenth of an inch thick, and perfectly transparent to light, is opaque to all the radiation from a source of 100°, transmits only 6 per cent. of the heat from a source at 400°, and but 39 of

the radiation from the lamp. Black glass, on the contrary, though it cuts off all heat from a source at 100° , allows 12 per cent. of that from the source at 400° to pass, and is equally transparent to the heat from the spiral, but on account of its blackness is more opaque to the heat from the lamp. As we have already seen, every luminous ray is a heat ray; now as several of the substances in this table are pervious to all the luminous rays, and yet, as in the case of ice, transmit about 6 per cent. of the radiation from a luminous source, we have an apparent anomaly; which, however, is only a confirmation of the remarkably small ratio which the energy of the luminous rays of a lamp bears to that of the obscure.

From these experiments Melloni concluded that as the temperature of the source rose, more heat was transmitted. This was confirmed by Tyndall. The platinum lamp (435) was used as the source, the temperature of which could be varied from a dark to a brilliant white heat, by a gradual augmentation of the strength of the electric current which heated the platinum spiral. Instead of liquids, vapours were examined in a manner to be described subsequently; the results of experiments are given in the following table.

Absorption of radiation by vapours

Name of vapour	Source, platinum spiral			
	Barely visible	Bright red	White hot	Near fusion
Carbon bisulphide	6.5	4.7	2.9	2.5
Chloroform	9.1	6.3	5.6	3.9
Methyl iodide	12.5	9.6	7.8	
Benzole	26.4	20.6	16.5	
Ether	43.4	31.4	25.9	23.7
Formic ether	45.2	31.9	25.1	21.3
Acetic ether	49.6	34.6	27.2	

The percentage of rays absorbed is here seen to diminish in each case as the temperature of the source rises. Mere rise of temperature does not, however, invariably produce a high penetrative power in the rays emitted: the rays from sources of far higher temperature than any of the foregoing are more largely absorbed by certain substances than are the rays emitted from any one of the sources as yet mentioned. Thus, the radiation from a hydrogen flame was completely intercepted by a layer of water only 0.27 of an inch thick, the same layer transmitting 9 per cent. of the radiation from the red-hot spiral, a source of much lower temperature. The explanation of this is, that those rays which heated water emits (and water the product of combustion is the main radiant in a hydrogen flame) are the very ones which this substance most largely absorbs. This statement, which will become clearer after considering the analogous phenomena in the case of light, was exemplified by the powerful absorption of the radiation from a carbonic oxide flame by carbonic acid gas. It will be seen presently (443) that of the rays from a heated plate of copper, ethylene absorbs ten times the quantity intercepted by carbonic acid, whilst of the rays from a carbonic

oxide flame Tyndall found carbonic acid absorbed twice as much as ethylene. Carbonic acid, at a pressure of a tenth of an atmosphere, enclosed in a tube 4 feet long, absorbs 60 per cent. of the radiation from a carbonic oxide flame. Radiation of this character can thus be used as a delicate test for the presence of carbonic acid, the amount of which may even be accurately measured by the same means. Professor Barrett made in this way a *physical* analysis of the human breath. In one experiment, the carbonic acid contained in breath physically analysed was found to be 4.65 per cent., whilst the same breath chemically analysed gave 4.66 per cent.

441. **Influence of the thickness and nature of screens.**—It will be seen from the table (440) that of every 100 rays incident upon it rock salt transmits 92. The other 8 may either have been absorbed or reflected from the surface of the plate. According to Melloni, the latter is the case; for if, instead of on one plate, heat be allowed to fall on two or more plates whose total thickness does not exceed that of the one, the quantity of heat arrested will be proportional to the number of reflecting surfaces. He therefore concluded that rock salt was quite diathermanous. Later experiments show that this conclusion is not strictly correct; rock salt does absorb a very small proportion of infra-red rays.

The quantity of heat transmitted through rock salt is practically the same, whether the plate be 1, 2, or 4 millimetres thick. But with other bodies absorption increases with the thickness, although by no means in direct proportion. This is seen to be the case in the table of absorption by liquids at different thicknesses. The following table tells what proportion of 1000 rays from a Locatelli's lamp pass through a glass plate of the given thickness:—

Thickness in millimetres	0.5	1	2	3	4	5	6	7	8	
Rays transmitted	. . .	775	733	682	653	634	620	609	600	592

The absorption takes place in the first layers; the rays which have passed these possess the property of passing through other layers in a higher degree, so that beyond the first layers the heat transmitted approaches a certain constant value. If a thin glass plate be placed behind another glass plate a centimetre thick, the former diminishes the transmission by little more than the reflection from its surface. But if a plate of alum were placed behind the glass plate, the result would be different, for the latter is opaque to much of the radiation transmitted by glass.

Radiation, therefore, which has traversed a glass plate traverses another plate of the same material with very slight loss, but is absorbed to a large extent by a plate of alum. Of 100 rays which had passed through green glass or tourmaline, only 5 and 7 were respectively transmitted by a similar plate of alum. A plate of blackened rock salt only transmits infra-red rays, while alum extinguishes them. Consequently, when these two substances are superposed, a system impervious to all radiation is obtained.

Besides thickness and colour, the polish of a substance influences the transmission. Glass plates of the same size and thickness transmit more radiation as their surface is more polished. Bodies which transmit heat of any kind very readily are not heated. Thus a window pane is not much heated by the strongest sun's heat; but a glass screen held before a common

fire stops most of the heat, and is itself heated thereby. The reason of this is that by far the greater part of the radiation from a fire is due to obscure or infra-red rays, and glass is opaque to this kind of radiation.

442. **Absorption of radiation from sources at different temperatures.**—Experiments were made by Melloni to determine the relative absorption by a number of substances of the rays emitted by red-hot platinum, copper at 400°, and copper at 100°. The results are as follows :—

Relative absorptive powers

	Incandescent platinum	Copper at 400°	Copper at 100°
Lampblack	100	100	100
White lead	56	89	100
Isinglass	54	64	91
Indian ink	95	87	85
Shellac	47	70	72
Polished metal	13.5	13	13

Hence white lead absorbs far less of the heat radiated from incandescent platinum than lampblack, but it absorbs the obscure rays from copper at 100° as completely as lampblack. Indian ink is the reverse of this ; it absorbs obscure rays less completely than luminous rays. Lampblack absorbs the radiation from all sources in equal quantities, and very nearly completely. In consequence of this property all thermoscopes which are used for investigating radiant heat are covered with lampblack, as it is the best known absorbent of radiation. The behaviour of metals is the reverse of that of lampblack. They reflect the heat of different sources in the same degree. They are to heat what *white* bodies are to light.

Nearly a century ago Franklin made experiments on coloured pieces of cloth, and found their absorption, indicated by their sinking into snow on which they were placed, to increase with the darkness of the colour. But all the cloths were equally powerful absorbents of obscure heat, and the effects noticed were only produced by their relative absorptions of light. In fact, the conclusions to be drawn from Franklin's experiments only hold good for luminous heat, especially sunlight such as he employed.

The rays of heat, like the rays of light, are susceptible of polarisation and double refraction. These properties will be better understood after the subject of light has been treated.

443. **Relation of gaseous substances to radiant heat.**—This subject was investigated by Tyndall ; the apparatus he used is represented in the adjacent figure, the arrangement being looked upon from above.

A (fig. 420) is a cylinder about 4 feet in length and $2\frac{1}{2}$ inches in diameter, placed horizontally, the ends of which can be closed with rock-salt plates ; by means of a lateral tube at *r* it can be connected with an air-pump and exhausted ; while at *l* is another tube which serves for the introduction of gases and vapours. T is a thermopile connected with a delicate galvanometer, M, the scale of which was carefully calibrated.

C is a source of heat, which usually was either a Leslie's cube filled

with boiling water, or else a sheet of blackened copper heated by gas. The radiation from it passed through the exhausted tube A and fell on one face of the thermopile. D was another cube of boiling water placed so as to radiate on the opposite face of the pile, the amount of heat falling on the

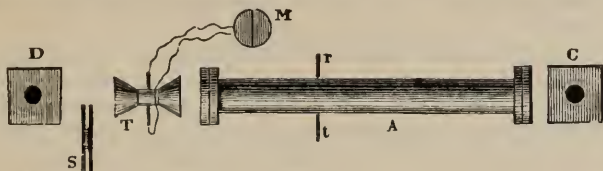

Fig. 420

pile from this *compensating* cube being regulated by means of a movable screen S. Since the strength of the thermo-electric current, and therefore the deflection of the galvanometer needle, depends upon the difference of temperature of the two faces of the thermopile, it is clear that when the compensation by D is perfect there will be no deflection, however high may be the temperature on either side. If now a gas be admitted into the exhausted tube, any power of absorption it may possess will be indicated by the destruction of this equilibrium, and preponderance of the radiation from the compensating cube by an amount corresponding to the heat cut off by the gas. Examined in this way, dry air, hydrogen, and nitrogen were found to exert an almost inappreciable effect; their presence as regards radiant heat being but little different from a vacuum. But with ethylene and other complex gases the case was entirely different. Representing by the number 1 the quantity of radiant heat absorbed by air, ethylene absorbs 970 times, and ammoniacal gas 1195 times, this amount. In the following table is given the absorption of obscure heat by various gases, referred to air as unity:—

Name of gas	Absorption under 30 inches of pressure	Name of gas	Absorption under 30 inches of pressure
Air	1	Carbonic acid	90
Oxygen	1	Nitrous oxide	335
Nitrogen	1	Marsh gas	403
Hydrogen	1	Sulphurous acid	710
Chlorine	39	Ethylene	970
Hydrochloric acid	62	Ammonia	1195

If, instead of comparing the gases at a common pressure of one atmosphere, they are compared at a common pressure of an inch, their differences in absorption are still more strikingly seen. Thus, assuming the absorption by 1 inch of dry air to be 1, the absorption by 1 inch of ethylene is 7950, and by the same amount of sulphurous acid 8800.

444. **Influence of pressure and thickness on the absorption of heat by gases.**—The absorption of heat by gases varies with the pressure; this variation is best seen in the case of those gases which have considerable

absorptive power. Taking the total absorption by atmospheric air under ordinary pressure at unity, the numbers of ethylene under a pressure of 1, 3, 5, 7, and 10 inches of mercury are respectively 90, 142, 168, 182, and 193. Thus ethylene, at a pressure of one-thirtieth of an atmosphere, exerts 90 times the absorption of air at ordinary pressure, and the absorption increases with the density.

In these experiments the length of the experimental tube remained the same, whilst the pressure of the gas within it was caused to vary: in subsequent experiments the pressure of the gas was kept constant, whilst the length of the tube was, by suitable means, varied from 0·01 of an inch up to 50 inches. The source was a heated plate of copper; of the total radiation from this nearly 2 per cent. was absorbed by a film of ethylene 0·01 of an inch thick, upwards of 9 per cent. by a layer of the same gas 0·1 of an inch thick, 33 per cent. by a layer 2 inches thick, 68 per cent. by a column 20 inches long, and 77 per cent. by a column rather more than 4 feet long.

445. Absorptive power of vapours.—The absorptive power of ethylene is exceeded by that of several vapours. The liquid from which the vapours were to be produced was enclosed in a small flask, which could be attached with a stopcock to the exhausted experimental tube. The absorption was then determined after admitting the vapours into the tube in quantities measured by the pressure of the barometer gauge attached to the air-pump.

The following table shows the absorption of vapours under pressures varying from 0·1 to 1 inch of mercury, the unit being the absorption of air at atmospheric pressure:—

Name of vapours	Absorption under pressure in inches of mercury		
	0·1	0·5	1·0
Carbon bisulphide	15	47	62
Benzole	66	182	267
Chloroform	85	182	236
Ether	300	710	870
Alcohol	325	622	—
Acetic ether	590	980	1195

Odours from the essential oils exercised a marked influence on radiant heat. Dry air was allowed to pass through a tube containing dried paper impregnated with various essential oils, and then admitted into the experimental tube. Taking the absorption of dry air as unity, the following were the numbers respectively obtained for air scented with various oils:—Patchouli 31, otto of roses 37, lavender 60, thyme 68, rosemary 74, cassia 109, aniseed 372. Thus the perfume of a flower-bed absorbs a large percentage of the heat of low refrangibility emitted from it.

Ozone prepared by electrolysing water was also found to have a remarkable absorptive effect. The small quantity of ozone present in electrolytic oxygen was found in one experiment to exercise 136 times the absorption of the entire mass of the oxygen itself.

But the most important results are those which follow from Tyndall's

experiments on the behaviour of aqueous vapour to radiant heat. Exhausting the tube, and admitting the ordinary undried, but not specially moist, air from the laboratory, the absorption was 72 times as great as that due to dry air. The difference between dried and undried air can only be ascribed to the aqueous vapour the latter contains. Thus on a day of average humidity the absorption due to the transparent aqueous vapour present in the atmosphere is 72 times as great as that of the air itself, though in quantity the latter is about 200 times greater than the former. Analogous results were obtained on different days, and with specimens of air taken from various localities.

The absorptive action which the aqueous vapour in the atmosphere exerts on the sun's heat has been established by a series of actinometrical observations made by Soret at Geneva and on the summit of Mont Blanc; he found that the intensity of the solar heat on the top of Mont Blanc is $\frac{6}{5}$ of that at Geneva; in other words, that of the heat which is radiated at the height of Mont Blanc, about $\frac{1}{3}$ is absorbed in passing through a vertical layer of the atmosphere 14,436 feet in thickness. The same observer has found that with the sun at heights which are virtually equal there is the smallest transmission of heat on those days on which the pressure of aqueous vapour is greatest; that is, when there is most moisture in the atmosphere.

446. **Radiating power of gases.**—Tyndall also examined the *radiating* power of gases. A red-hot copper ball was placed so that the current of heated air which rose from it acted on one face of a thermopile; this action was compensated by a cube of hot water placed in front of the opposite face. On then allowing a current of dry ethylene from a gasholder to stream through a ring burner over the heated ball, and thus supplant the ascending current of hot air, it was found that the gas radiated energetically. By comparing in this manner the action of many gases it was discovered that, as is the case with solids, those gases which are the best absorbers are also those which radiate most freely.

447. **Relation of absorption to molecular state.**—After examining the absorption of heat by vapours, Tyndall tried the same substances in a liquid form in the same conditions of experiment. The source of heat was a spiral of platinum heated to redness by an electric current of known strength; and plates of rock salt were invariably employed in the case of both vapours and liquids. Finally, the absorption by the vapours was re-measured; in this case by introducing into the experimental tube, not, as before, equal quantities of vapour, but amounts proportional to the density of the liquid. When this last condition had been attained, it was found that the order of absorption by a series of liquids, and by the same series when turned into vapour, was precisely the same. Thus the substances tried stood in the following order as liquid and as vapour, beginning with the feeblest absorbent, and ending with the most powerful:—

Liquids	Vapours
Carbon bisulphide	Carbon bisulphide.
Chloroform	Chloroform.
Ethyl iodide	Ethyl iodide.
Benzole	Benzole.
Ether	Ether.
Alcohol	Alcohol.
Water	

A direct determination of aqueous vapour could not be made, on account of its small elastic force and the hygroscopic nature of the rock salt. But the undeviating regularity of the absorption by all the other substances in the list, both as liquids and vapour, establishes the fact, which is corroborated by the experiments already mentioned, that aqueous vapour is one of the most energetic absorbents of heat.

In this table it will be noticed that those substances which have the simplest chemical constitution stand first in the list, with one anomalous exception, namely, that of water. In the absorption of heat by gases, Tyndall found that the elementary gases were the feeblest absorbents, while the gases of most complex constitution were the most powerful absorbents. Thus it may be inferred that absorption is mainly dependent on chemical constitution; that is to say, that absorption and radiation are molecular acts independent of the physical condition of the body.

448. **Applications.**—The properties which bodies possess of absorbing, emitting, and reflecting heat meet with numerous applications in domestic economy and in the arts. Leslie stated in a general manner that white bodies reflect heat very well, and absorb very little, and the contrary is the case with black substances. As we have seen, this principle is not generally true, as Leslie supposed; for example, white lead has as great an absorbing power for non-luminous rays as lampblack (442). Leslie's principle applies to powerful absorbents like cloth, cotton, wool, and other organic substances when exposed to radiation from luminous sources. Accordingly, the most suitable coloured clothing for summer is just that which experience has taught us to use, namely, white, for it absorbs less of the sun's rays than black clothing, and hence feels cooler.

The polished fire-irons before a fire are cold, whilst the black fender is often unbearably hot. If, on the contrary, a liquid is to be kept hot as long as possible, it must be placed in a brightly polished metallic vessel, for then, the emissive power being less, the cooling is slower. Hence it is advantageous that the steam pipes, &c., of locomotives should be kept bright. In the Alps, the mountaineers accelerate the fusion of the snow by covering it with earth, which increases the absorbing power.

In our dwellings, the outside of stoves and of hot-water apparatus ought to be black, and the insides of fireplaces ought to be lined with firebrick, in order to increase the radiating power towards the apartment.

It is owing to the great diathermancy of dry atmospheric air that the higher regions of the atmosphere are so cold, notwithstanding the great heat which traverses them; whilst the intense heat of the sun's rays on high mountains is probably due to the comparative absence of aqueous vapour at these elevations.

As a considerable part of solar radiation is transmitted by water, accidents have often arisen from the convergence of the sun's rays by bottles of water which act as lenses. In this way gunpowder could be fired by the heat of the sun's rays concentrated by a water lens; and the drops of water on leaves in greenhouses have been found to act as lenses and burn the leaves on which they rest.

Certain bodies can be used (437) to separate the heat and light radiated from the same source. Rock salt coated with lampblack, or still better with

iodine, transmits heat, *i.e.* the infra-red rays, but completely stops light. On the other hand, alum, either as a plate or in solution, or a thin layer of water, is permeable to light, but stops all the heat from obscure sources. This property is made use of in apparatus illuminated by the sun's rays, in order to sift the rays of their heating power; a vessel full of water or a solution of alum is used with the electric light when it is desirable to avoid too intense a heat.

In gardens, the use of shades to protect plants depends partly on the diathermancy of glass for heat from luminous rays and its athermancy for obscure rays. The heat which radiates from the sun is largely of the former quality, but by contact with the earth it is changed into obscure heat, which, as such, cannot retrace the glass. This explains the manner in which greenhouses accumulate their warmth, and also the great heat experienced in summer in rooms having glass roofs, for the glass in both cases acts, as it were, as a valve which effectually entraps the solar rays. On the same principle plates of glass are frequently used as screens to protect us from the heat of a fire; the glass allows us to see the cheerful light of the fire, but intercepts the larger part of the heat radiated from the fire. Though the screens thus become warm by the heat they have absorbed, yet, as they radiate this heat in all directions towards the fire as well as towards us, we finally receive less heat when they are interposed.

449. **Attraction and repulsion arising from radiation.**—Crookes discovered a highly remarkable class of phenomena which are due to the radiant action of heated and of luminous bodies. These phenomena are most conveniently illustrated by means of an instrument which he has devised, and which is called the *radiometer*, the construction of which is as follows:—A glass tube (fig. 421), with a bulb blown on it, is fused at the bottom to a glass tube which at one end serves to rest the whole apparatus in a wooden support. In the other end is fused a fine steel point. On this rests a small vane or fly, consisting of four arms of aluminium wire fixed at one end to a small cap, while at the others are fixed small discs or lozenges of thin mica, coated on one side with lampblack. The weight of the fly is not more than two grains. The enclosed air is reduced by a Sprengel pump to any desired degree of rarefaction.

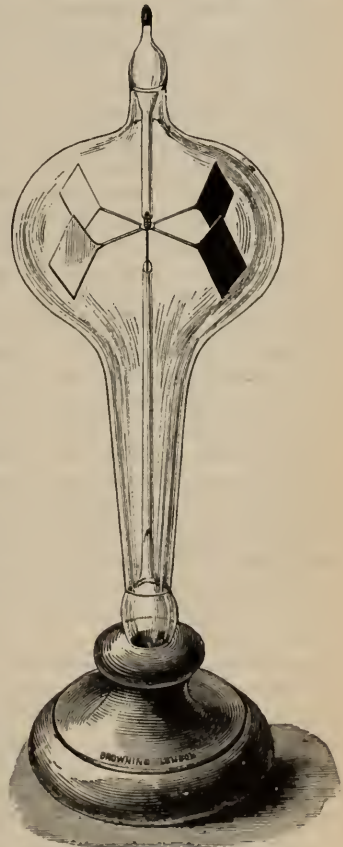

Fig. 421

If a source of light or of heat, a candle for instance, is brought near the apparatus, the fly rotates slowly in a direction showing that the blackened side moves towards the light; this movement, indicating an attraction, depends on a certain state of rarefaction. If, however, the apparatus is connected with an arrangement which allows the pressure to be varied, the rotation of the fly gradually diminishes in rapidity as the air within is further rarefied, until a certain point is reached at which it ceases. If the rarefaction is pushed further, repulsion succeeds to attraction, and the blackened faces of the vanes move in the direction away from the source of heat. In a double radiometer, in which two flies are pivoted independently one over the other, having their blackened sides opposite each other, the flies rotate in opposite directions on the approach of a lighted candle. When a cold body, such as a piece of ice, is brought near, instead of a hot one, the rotations are reversed.

One of the most important facts brought to light by these experiments is, that what has hitherto been looked upon as a complete vacuum is not so in reality; the most perfect vacuum obtainable still contains a certain residue of gas, as has been proved by the experiments of Crookes and others, among which that of Kundt may be mentioned. The latter placed on the vanes a light disc of mica, and at a little distance above it a similar disc was arranged so as to rotate freely in a horizontal plane independently of the first. When the lower vane was made to rotate by bringing a light near, it was found that the upper disc was also put in rotation in the same direction, being dragged by the viscosity of the residual air. Accordingly the explanation of the phenomena of the radiometer must take into account the existence of this gaseous residue.

The nature of the gas seems to have no special influence on the phenomena; whether the vacuum is one of hydrogen, of aqueous vapour, or of iodine vapour, seems immaterial; though with hydrogen the exhaustion need not be pushed so far as with air. The repulsion takes place with all the rays of the spectrum, the intensity diminishing from the infra-red to the ultra-violet. When the chemical rays, *i.e.* the violet and ultra-violet, act, the interposition of a plate of alum has no effect, while a solution of iodine in carbon bisulphide diminishes the repulsion. The rate at which the vane rotates depends on the intensity of the source of light. With a strong light the rotation is so rapid that its rate cannot be determined. With two candles at the same distance the rotation is twice as rapid as with one. Two sources of light, which, successively placed at the same distance, produce the same rate of rotation, are equal in intensity. If, when placed at different distances, they produce the same speed of rotation, their intensities are directly as the squares of these distances from the radiometer. On this is based the use of the instrument as a photometer (520) for comparing together various sources of artificial light. It may likewise be used for making comparative measurements of the intensity of sunlight; and the distribution of energy in the solar spectrum may be investigated by its means.

It is not difficult to understand that the attraction of the blackened face observed in the experiments may be explained by the action of convection currents (414), as long as the apparatus still contains air, *i.e.* when the pressure has not been reduced beyond a certain point. For heat falling upon

this blackened disc would raise its temperature, and the temperature of a layer of air in immediate contact with the disc would be raised too ; it would expand and rise, flowing over into the space behind the disc, and would thus increase the pressure there. On the other hand, the repulsion observed at the higher degrees of exhaustion is due to a reaction between the vane and the glass envelope, and is explained by the modern views as to the constitution of gases, of which it is at once an illustration and a proof.

The general nature of this theory is that a gas is an assemblage of independent molecules, which are perfectly elastic, and which move with great rapidity ; their impacts against the sides of the vessel in which the gas is contained are the cause of the pressure. The impact of the molecules against each other is the mechanism by which the equal transmission of pressure in gases is effected (295).

Crookes has calculated that the mechanical effect of the force of repulsion is equal to about the $\frac{1}{1000}$ of a milligramme on a square centimetre, and Stoney has shown that this force is sufficient to account for the effects observed, by reference to admitted principles of the mechanical theory of gases.

The radiation passes through the thin glass without raising its temperature, and, falling on the blackened side of the vane, is absorbed by it ; the consequence of this is, that it will become slightly hotter. The layer of extremely rarefied air in immediate contact with the blackened disc will also become somewhat hotter, and the molecules will fly from the disc with greater velocity. Under ordinary pressures or even at moderate degrees of rarefaction these more rapid motions would be equalised by their impacts against other molecules, and a uniformity of pressure—that is, of temperature—would be established. But the frequency of these intermolecular shocks diminishes rapidly with the increase of rarefaction ; and the consequence is, that a great number of molecules, after having been heated by contact with the blackened side of the palette, will strike against the cold glass. The effect of this will be to cool these molecules, that is to diminish their velocity ; it will be chiefly molecules of this kind which fall on the back of the disc, and on the regions behind it. An excess of force equal and opposite to that on the glass acts against the front of the disc, and is sufficient to account for the phenomena exhibited by Crookes.

It follows from this explanation that, other things being equal, a fly will rotate more rapidly in a small than in a large bulb. This has been conclusively proved by Crookes, who constructed a double-bulb radiometer, the two bulbs being very different in size, and so connected that, by dexterous manipulation, the fly could be transferred from the pivot of the one to that of the other bulb. The complete explanation of the action of the radiometer was first given by Osborne Reynolds.

Maxwell's electromagnetic theory of light involves as one of its results that light must exercise a direct mechanical pressure on a surface on which it falls. Recent experiments by Lebedew, Nicholls and Hull, and others, have shown the reality of this pressure.

450. **Internal friction or viscosity of gases.**—In some experiments in connection with the radiometer, Crookes used an arrangement consisting of a long but light arm of straw suspended by a delicate glass fibre in a sort of T tube turned upside down ; in this way even a greater degree

of delicacy was obtained than with the radiometer. Thus he was able to get a deflection by moonlight, which does not move the fly of the radiometer. He examined the internal friction or viscosity of the residual gas (193) by causing the arm to oscillate, and then observing the rate at which the oscillations diminish under various pressures. He thus found that from ordinary pressures down to a pressure of 0.19 mm., or what may be called a Torricellian vacuum, the viscosity is practically constant, only diminishing from 0.126 to 0.112. It now begins to fall off, and at a pressure of 0.000076 mm. it has diminished to 0.01, or about $\frac{1}{12}$. Simultaneously with this decrease in viscosity the force of repulsion excited by a standard light on a blackened surface varies. It increases as the pressure diminishes until the exhaustion is about 0.05 mm., and attains its maximum at about 0.03 mm. It then sinks very rapidly until it is at 0.000076 mm., when it is less than $\frac{1}{10}$ of its maximum.

The viscosity varies in different gases; it is considerably less in hydrogen than in air: and hence with this gas it is not necessary to drive the exhaustion so far to produce a considerable degree of repulsion.

451. Relation of radiant heat to sound.—This subject has engaged the attention of several physicists, among whom may be particularised Bell and Tainter, Tyndall, Preece, and Mercadier. A convenient way of showing the phenomena is by means of an apparatus constructed by Duboscq, the essential features of which are represented in fig. 423. It is an arrangement by which an intermittent beam of radiant heat may be made to act on various bodies, and consists of a disc D mounted on a horizontal axis, and which, by means of the multiplying wheels P and P', may be rotated at any desired speed. In the disc is a series of holes, the numbers of which are in some multiple of the ratio 4 : 5 : 6 : 8. This apparatus constitutes in fact a siren (242), and is very convenient for lecture purposes. If, while the disc is rotating with uniform speed, a current of air is successively directed against the rows of holes from the inside to the outside, we get the fundamental note, the third, the fifth, and the octave.

On the stand is a support on which the arrangement O may be fixed in any position by means of the screw *s*; it consists of a screen and wide tube behind which is the source of radiant heat, not represented in the figure. To this support may be fitted a double convex lens, if the rays are to be concentrated on one line of holes, or a cylindrical lens when a slice of thermal rays is to be used; or the rays may be concentrated by a mirror, to get rid of the effects of absorption by glass.

When a flask (fig. 422) containing a small quantity of ether, was placed so that the intermittent beam from a limelight could fall on it, and the top was connected with a flexible tube, a distinct musical note was heard when the ear-trumpet was held to the ear. Other liquids being tried, it was found that those which experiments had revealed as the best absorbers of heat (444) gave also the loudest sounds. The vapour was the operative cause, for when the beam was caused to strike against the liquid instead of against the vapour no sound was heard; this was also the case when the rays fell on a rock-salt cell filled with the liquid. The pitch of the note depended on the velocity of rotation.

Dry air gave no sound, but air containing moisture did so; and the

more moisture was present the louder was the sound. Other gases gave sounds in the order of their absorption for heat ; and, indeed, all Tyndall's results in this direction are most strikingly confirmed.

The investigations of the other experimenters, Preece, Bell and Tainter, and Mercadier, were chiefly directed to the effects produced when the intermittent beam is allowed to fall on solid bodies. A sort of ear-trumpet (fig. 424) was used by Mercadier, consisting of a movable piece *ab* fitting over *cd*, so that plates *L* of various materials could be experimented upon. The other end *f* was fitted with a flexible tube and bell so that it could be applied to the ear.

When the intermittent beam is allowed to act on this plate it is set in vibration and a sound is produced. This is not due, at any rate mainly, to

Fig. 422

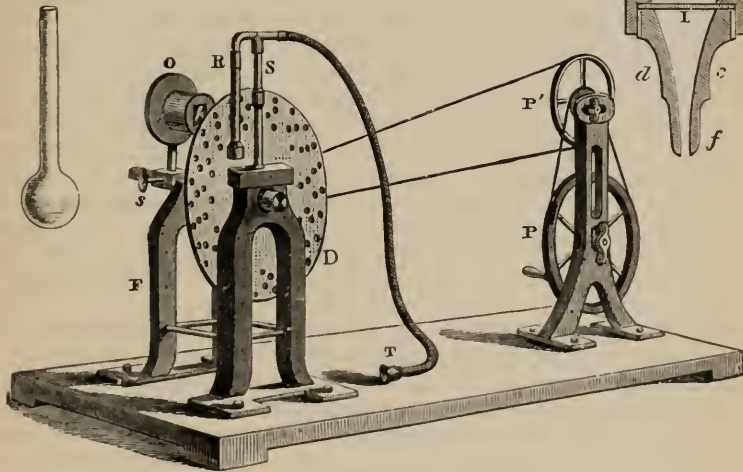
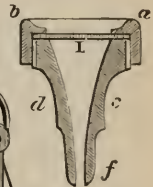

Fig. 423

Fig. 424



transverse vibrations of the plate, for neither the pitch nor the quality of the note was altered when the thickness and nature of the plate were changed (284), nor was it altered when the plate was slit. The best effects were obtained when the diaphragm was of thin metal foil coated with lampblack on the side next the rays. Marked effects were also obtained when a transparent plate was used blackened on the side away from the rays. The effect is one of radiant heat, and is essentially due to alternate expansions and contractions of the layer of air in contact with the surfaces which absorb the radiant heat. The phenomenon may be very simply exhibited by blackening half the inside of a test-tube, the open end of which is provided with a flexible tube which can be placed to the ear. When the rays fall on the blackened part a loud sound is heard, but very little when the bright side is exposed. The effect is also obtained when a blackened piece of foil is placed in the tube.

CHAPTER IX

CALORIMETRY

452. **Calorimetry. Thermal unit.**—Calorimetry measures the *quantity of heat* which a body parts with or absorbs, when its temperature sinks or rises through a certain number of degrees, or when it changes its condition.

Quantities of heat may be expressed by any of its directly measurable effects, but the most convenient is the alteration of temperature, and quantities of heat are usually defined by stating the temperature to which they are capable of raising a known weight of a known substance, such as water. The unit chosen for comparison, and called the *thermal unit*, is not everywhere the same ; it depends upon the units of mass and temperature adopted. A *calorie* is the quantity of heat required to raise the temperature of one gramme of water through one degree Centigrade ; a *great calorie* is 1000 times this. These units of heat are often referred to as a gramme-degree Centigrade and a kilogramme-degree Centigrade respectively. The pound-degree Centigrade is a unit which it is often convenient to use ; it is the *quantity of heat necessary to raise one pound of water through one degree Centigrade*.

453. **Specific heat.**—When equal weights of two different substances, at the same temperature, placed in similar vessels, are subjected for the same length of time to the heat of the same lamp, or are placed at the same distance in front of the same fire, it is found that their temperatures will vary considerably ; thus mercury will be much hotter than water. But as, from the conditions of the experiment, they have each been receiving the same amount of heat, it is clear that the quantity of heat which is sufficient to raise the temperature of mercury through a certain number of degrees will raise the temperature of the same quantity of water only through a less number of degrees ; in other words, that it requires more heat to raise the temperature of water through one degree than it does to raise the temperature of the same quantity of mercury by the same extent. Conversely, if the same quantities of water and of mercury at 100° C. are allowed to cool down to the temperature of the air the water will require a much longer time for the purpose than the mercury ; hence, in cooling through the same number of degrees, water gives out more heat than does mercury.

It is readily seen that all bodies have not the same specific heat. If a pound of mercury at 100° is mixed with a pound of water at zero, the temperature of the mixture will be about 3° only ; that is to say, that while the mercury has cooled through 97° , the temperature of the water has been raised only 3° . Consequently the same weight of water requires about 32 times as much heat as mercury does, to produce the same elevation of temperature.

If similar experiments are made with other substances, it will be found that the quantity of heat required to effect a certain change of temperature is different for almost every substance, and we speak of the *specific heat*, or *thermal* or *calorific capacity*, of a body as the quantity of heat which it absorbs when its temperature rises through a given range, from zero to 1° for example, compared with the quantity of heat which would be absorbed, in the same circumstances, by the same weight of water; that is, water is taken as the standard for the comparison of specific heats. Thus, to say that the specific heat of lead is 0.0314 , means that the quantity of heat which would raise the temperature of any given weight of lead through 1° C. would raise the temperature of the same weight of water through only 0.0314° C., or that 0.0314 thermal unit is required to heat one pound of lead through 1° C.

The temperature of a body depends upon the *kinetic energy* of its smallest particles; in bodies of the same temperature the atoms have the same energy of motion, the smaller mass of the lighter atoms being compensated by their greater velocity. The heat absorbed by a body not only raises its temperature—that is, increases the energy of the progressive motion of the atoms—but in overcoming the attraction of the atoms it moves them further apart, and along with the expansion which this represents, some external pressure is overcome. In the conception of specific heat is included not merely that amount of heat which goes to raise the temperature, but also that necessary for the internal work of expansion, and that required for the external work. If these latter could be separated, we should get the true *heat of temperature*, that which is used solely in increasing the energy of motion of the atoms. This is sometimes called the *true specific heat*.

Four methods have been employed for determining the specific heats of bodies: (i.) the method of the melting of ice, (ii.) the method of mixtures, (iii.) that of cooling, and (iv.) the method of the steam calorimeter. Previously to describing these methods, it will be convenient to explain the expression for the quantity of heat absorbed or given out by a body of known weight and specific heat, when its temperature rises or falls through a certain number of degrees.

454. **Measure of the sensible heat absorbed by a body.**—Let m be the mass of a body in pounds, c its specific heat, and t its temperature. The quantity of heat necessary to raise a pound of water through 1° C. being taken as unity, m of these units would be required to raise m pounds of water through one degree, and to raise it through t degrees, t times as much, or mt . As this is the quantity of heat necessary to raise through t degrees m pounds of water, whose specific heat is unity, a body of the same weight, only of different specific heat, c , would require mtc . Consequently, when a body is heated through t degrees, the quantity of heat which it absorbs is *the product of its weight into the range of temperature into its specific heat*. This principle is the basis of all the formulæ for calculating specific heats.

If a body is heated or cooled from t to t' degrees, the heat absorbed or disengaged will be represented by the formula

$$m(t' - t)c, \text{ or } m(t - t')c.$$

455. **Method of the fusion of ice.**—This method of determining specific heats is based on the fact that to melt a pound of ice 80 thermal units are necessary. Black's calorimeter (fig. 425) consists of a block of ice in which a cavity is made, and which is provided with a cover of ice. The substance whose specific heat is to be determined is heated to a certain temperature, and is then placed in the cavity, which is covered. After some time the body becomes cooled to zero. It is then opened, and both the substance and the cavity wiped dry with a sponge which has been previously weighed. The increase of weight of this sponge obviously represents the ice which has been converted into water.

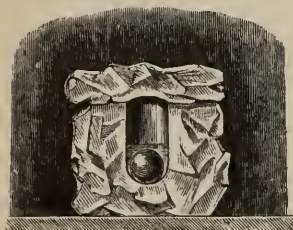

Fig. 425

Now, since one pound of ice at 0° in melting to water at 0° absorbs 80 thermal units (344), P pounds absorb 80 P units. On the other hand, this quantity of heat is equal to the heat given out by the body in cooling from t° to zero, which is mtc , for it may be taken for granted that in cooling from t° to zero a body gives out as much heat as it absorbs in being heated from zero to t° . Consequently from

$$mtc = 80 P \text{ we have } c = \frac{80 P}{mt}.$$

Lavoisier and Laplace replaced the block of ice used by Black in his experiments by a more complicated apparatus which is called the *ice calorimeter*. Fig. 426 represents a section. It consists of three concentric tin vessels; in the central one is placed the body M , whose specific heat is to be determined, while the other two are filled with pounded ice. The ice in the compartment A is melted by the heated body, while the ice in the compartment B cuts off the heating influence of the surrounding atmosphere. The two stopcocks E and D give issue to the water which arises from the melting of the ice.

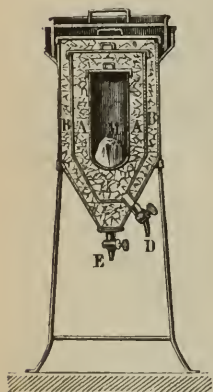

Fig. 426

In order to find the specific heat of a body by this apparatus, its weight, m , is first determined; it is then raised to a given temperature, t , by keeping it for some time in an oil or water bath, or in a current of steam. Having been quickly brought into the central compartment, the lids are replaced and covered with ice, as represented in the figure. The water which flows out by the stopcock D is collected. Its weight, P , is manifestly that of the melted ice. The calculation is then made as in the preceding case.

456. **Bunsen's ice calorimeter.**—On the very considerable diminution of volume which ice experiences on passing into water (349), Bunsen based a calorimeter which is particularly suitable when only small quantities of a

substance can be used in determinations. A small test-tube or *muffle*, A (fig. 427), intended to receive the substance experimented upon, is fused in the wider tube $\gamma\beta$, which contains pure freshly boiled distilled water, and the prolongation of this tube βC , together with the graduated capillary tube S, contains pure mercury. It is graduated, and the volume corresponding to each division of the graduation is specially determined by calibration; it is joined to βC by the small mercury reservoir δD . When the apparatus is immersed in ice, and the temperature reduced to 0°C ., some ether is introduced into A and rapidly evaporated. This abstracts heat from the water, and a casing of ice gathers round the outside of A. The tube is then dried, and the apparatus, still surrounded by ice to prevent any rise of temperature, is left to itself until the end of the capillary column in S is stationary. A weighed quantity of a substance at a given temperature is then introduced into the tube, and sinks to zero. In doing so it melts a certain quantity of

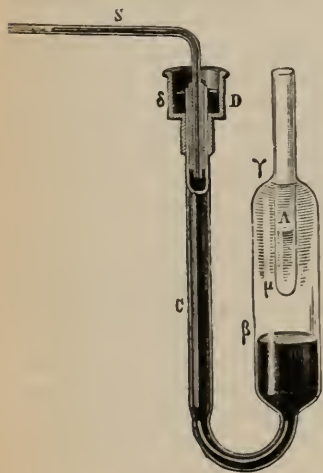

Fig. 427

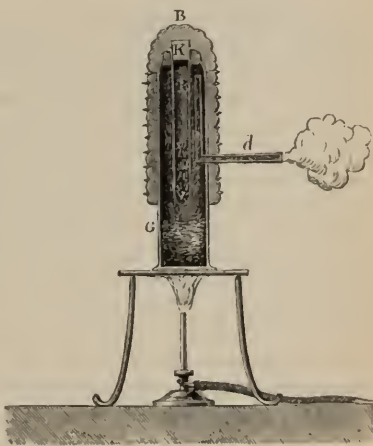

Fig. 428

ice, which is evidenced by a corresponding motion of the mercury along the tube S. Thus the weight of ice melted, and the weight and original temperature of the substance experimented upon, furnish all the data for calculating the specific heat.

Let v = the diminution in volume due to melting of the ice; v is read off from the tube S.

Since 1 c.c. of ice at 0° yields .9178 c.c. of water at 0° , the contraction is .0822 c.c. Hence, if the contraction is 1 c.c., the water resulting from the melting is $\frac{.9178}{.0822} = 11.1$ c.c.; $\therefore 11.1 \times v$ is the volume of water in c.c. (due to the melting of the ice round A), and therefore its weight in grammes. Hence $11.1 \times v \times 80 = mtc$, where 80 is taken as the latent heat of water, m the mass of the substance, t its original temperature, and c its specific heat. From this, c , the specific heat of the substance is obtained.

For heating the substance in this, and also in other calorimetric experiments, the apparatus fig. 428 is well adapted. The cylindrical metal vessel G narrows towards the top and is closed by a cork into which the test-tube R is fitted. In this glass tube, which is also closed by the cork K, the substance is placed which is to be heated. The greater part of the vessel is covered by a thick mantle of felt, B. The water in the vessel is boiled, the steam emerging at d , until the substance has acquired the temperature of boiling water, for which about twenty minutes is required. The mantle and the lamp having been taken away, the tube R is rapidly removed, and its contents tipped into the tube A of the calorimeter (fig. 427).

For this method of determining specific heat a new determination of the latent heat of ice was made, and it was found to be $80\cdot025$. It was also in connection with these experiments that Bunsen made his determination of the specific gravity of ice, which he found to be in the mean $0\cdot91674$.

By the above method Bunsen determined the specific heat of several of the rare metals for which a weight of only a few grains could be used.

457. **Method of mixtures.**—In the determination of the specific heat of a solid body by this method the substance is weighed and raised to a known temperature by keeping it, for instance, for some time in a closed place heated by steam; it is then immersed in a mass of cold water, the weight and temperature of which are known. From the rise of temperature of the water after mixture the specific heat of the body is determined.

Let M be the mass of the body, T its temperature, c its specific heat; and let m be the mass of the cold water, and t its temperature.

As soon as the heated body is plunged into the water, the temperature of the latter rises until both are at the same temperature. Let this temperature be θ . The heated body has been cooled by $T - \theta$; it has, therefore, lost a quantity of heat, $M(T - \theta)c$. The water has, on the contrary, absorbed a quantity of heat equal to $m(\theta - t)$, for the specific heat of water is unity. Now the quantity of heat given out by the body is manifestly equal to the quantity of heat absorbed by the water; that is, $M(T - \theta)c = m(\theta - t)$, from which

$$c = \frac{m(\theta - t)}{M(T - \theta)}.$$

458. **Corrections.**—The vessel containing the water is usually a small cylinder of silver or brass, with thin polished sides, and is supported by some badly conducting arrangement. It is obvious that this vessel, which is originally at the temperature of the cold water, shares its increase of temperature, and in accurate experiments this must be allowed for. The decrease of temperature of the heated body is equal to the increase of temperature of the water, and of the vessel in which it is contained. If the weight of this latter be m' , and its specific heat c' , its temperature, like that of the water, is t : consequently the previous equation becomes

$$Mc(T - \theta) = m(\theta - t) + m'c'(\theta - t);$$

from which, by obvious transformations,

$$c = \frac{(m + m'c')(\theta - t)}{M(T - \theta)}.$$

Generally speaking, the value $m'c'$ is put $=\mu$; that is to say, μ is the mass of water which would absorb the same quantity of heat as the vessel. This is said to be the *water-equivalent* of the vessel. The expression accordingly becomes

$$c = \frac{(m + \mu)(\theta - t)}{M(T - \theta)}.$$

In accurate experiments it is necessary to allow also for the heat absorbed by the glass and mercury of the thermometer, by introducing into the equation their water-equivalents; and to allow for the loss of heat by radiation, a preliminary experiment is made with the body whose specific heat is sought, the only object of which is to ascertain approximately the increase of temperature of the cold water. If this increase be 10° , for example, the temperature of the water is reduced by half this number—that is to say, 5° —below the temperature of the atmosphere, and the experiment is then carried out in the ordinary manner.

By this method of compensation, first introduced by Rumford, the water receives as much heat from the atmosphere, during the first part of the experiment, as it loses by radiation during the second part.

459. **Regnault's apparatus for determining specific heats.**—Fig. 429 represents one of the forms of apparatus used by Regnault in determining specific heats by the method of mixtures.

The principal part is a steam bath, $\Lambda\Lambda$, of which fig. 430 represents a section. It consists of three concentric compartments; in the central one there is a small basket of brass wire, c , containing fragments of the substance whose specific heat is to be determined, in the middle of which is placed a thermometer, T . The second compartment is heated by a current of steam coming through the tube e from the boiler B , and passing into a worm, a , where it is condensed. The third compartment ii' , is an air chamber to hinder the loss of heat. The steam bath, $\Lambda\Lambda$, rests on a chamber, K , with double sides, EE , forming a jacket which is kept full of cold water, in order to exclude the heat from $\Lambda\Lambda$, and from the boiler, B . The central compartment of the steam bath is closed by a damper, r , which can be opened at pleasure, so that the basket c can be lowered into the chamber K .

On the left of the figure is represented a small and very thin brass vessel, D , suspended by silk threads on a small carriage, which can be moved out of or into the chamber, K . This vessel, which serves as a calorimeter, contains water, in which is immersed a thermometer, t . Another thermometer at the side, t' , gives the temperature of the air.

When the thermometer T shows that the temperature of the substance in the bath is stationary, the screen h is raised, and the vessel D moved to just below the central compartment of the steam bath. The damper r is then withdrawn, and the basket c and its contents are lowered into the water in the vessel D , the thermometer T remaining fixed in the cork. The carriage and the vessel D are then moved out, and the water agitated until the thermometer t becomes stationary. The temperature which it indicates is θ . This temperature known, the rest of the calculation is made in the manner described in article 452, care being taken to make all the necessary corrections.

In determining the specific heat of substances—phosphorus, for instance—which could not be heated without causing them to melt, or undergo some change which would interfere with the accuracy of the result, Regnault adopted an inverse process: he cooled them down to a temperature considerably below that of the water in the calorimeter, and then observed the diminution in the temperature of the latter, which resulted from immersing the cooled substance in it.

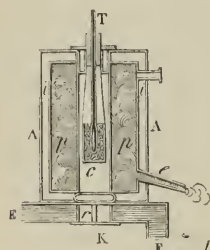

Fig. 430

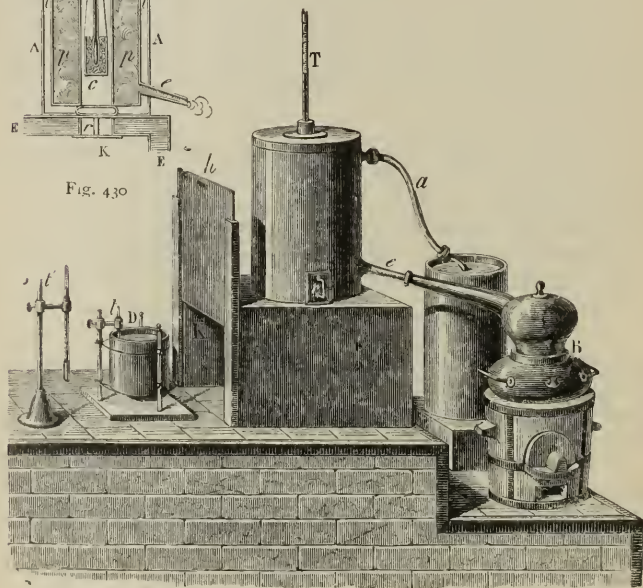

Fig. 429

In determining the specific heat of substances which, like potassium would decompose water, some other liquid must be used, such as turpentine or benzole. These liquids have the additional advantage of having a lower specific heat than water, so that an error in determining the temperature of the cooling liquid has a less influence on the value of the specific heat of the substance. With this view use has been made of mercury, the specific heat of which is only one-thirtieth that of water.

460. **Method of cooling.**—Equal weights of different bodies whose specific heats are different will occupy different times in cooling through the same number of degrees. Dulong and Petit applied this principle in determining the specific heats of bodies in the following manner:—A small polished silver vessel, *V* (fig. 431), is filled with the substance in a state of fine powder, and a thermometer placed in the powder, which is pressed down.

This vessel is heated to a certain temperature, and is then introduced into a copper vessel, E, in which it fits hermetically, being suspended by silk threads. This copper vessel is exhausted through the tube t' , and maintained at the constant temperature of melting ice, MN, and the time noted which the substance takes in falling through a given range of temperature, from 15° to 5° for example. The times which equal weights of different bodies require for cooling, through the same range of temperature, when the radiating surface is the same in each case, are directly as their specific heats.

Regnault proved that this method does not give trustworthy results with solids; it assumes, which is not quite the case, that the cooling in all parts is equal, and that all substances part with their heat to the silver case with equal facility. The method may, however, be employed with success in the determination of the specific heat of liquids.

Since the emissive power of the silver vessel is the same in all cases, as is also the temperature-fall, the quantity of heat lost is proportional to the time. Hence, if m , m' are the masses of the substances (powders or liquids) just filling the vessel V; c , c' their specific heats, and t , t' the respective times of cooling from θ' to θ ,

$$mc(\theta' - \theta) = kt, \text{ (} k \text{ being a constant), and } m'c'(\theta' - \theta) = kt'; \therefore \frac{mc}{m'c'} = \frac{t}{t'}$$

If, for example, the second substance is water, $c' = 1$, and m/m' is the density (σ) of the substance whose specific heat is required,

$$\therefore c = \frac{t}{\sigma t'}$$

In an investigation of the specific heats of various soils, Pfaundler found that a soil of low specific heat heats and cools rapidly, while earth of higher specific heat undergoes slow heating and slow cooling; that moist earths rich in humus have a high specific heat, amounting in the case of turf to as much as 0.5; while dry soils free from humus, such as lime and sand, have a low specific heat, not more than about 0.2.

461. Condensation method.—The determination of specific heat by the condensation of steam has been in recent years carried out with success by J. Joly (1886). The principle of the method is as follows:—A known weight of the substance whose specific heat is required, at a known temperature, is suddenly enveloped in saturated steam, some of which condenses upon it. It is now weighed in the steam, and weighs more than before, in consequence of the steam condensed upon it. If w is the increase of weight, wL represents the quantity of heat given up by the steam in condensing; and if W is the weight of the body at the low temperature (t_1), t_2 the temperature of the steam, and c the specific heat of the substance, $Wc(t_2 - t_1)$ = heat

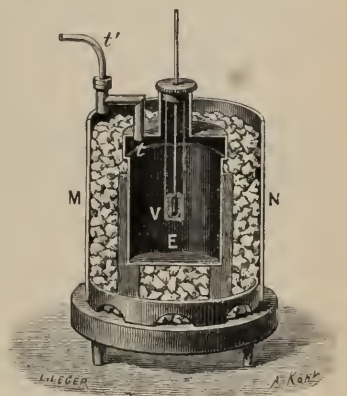

Fig. 431

absorbed by the substance, and this must be equal to wL , whence c is determined.

In its simplest form Dr. Joly's apparatus consists of a thin metal enclosure or chamber, A (fig. 432), in which there hangs from the arm of a

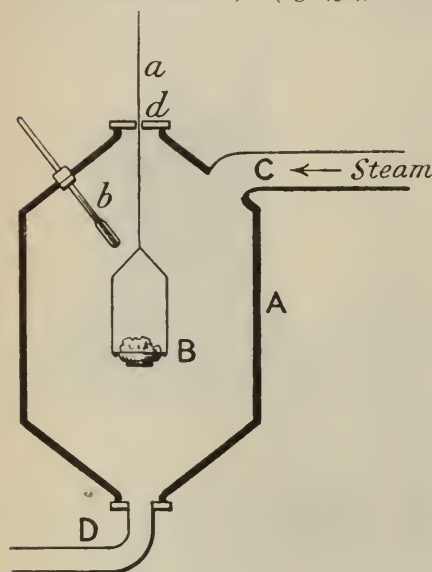

Fig. 432

figure. When the temperature has become steady, as indicated by the sensitive thermometer, b , steam is suddenly admitted, so that the whole chamber becomes filled with saturated vapour. Condensation at once begins on the substance, and the resulting water is caught in the platinum pan B, weights being added to the other pan of the balance to restore equilibrium. During this process the steam is admitted very slowly into the chamber, so that the pan may not be subjected to any steam draught. After four or five minutes the condensation is complete, and no further increase of weight takes place. The specific heat is determined from the equation

$$(Wc + m)(t_2 - t_1) = wL,$$

where m is the water equivalent of the platinum pan, determined by a preliminary experiment, the other letters having the meanings given to them above; t_2 , the temperature of the steam, is determined by the barometric pressure from Regnault's table; $L = 596.73 - .601t_2$ (468). A correction must be introduced in consequence of the first weighing being made *in air* at t_1° , while w is weighed *in steam* at t_2° .

462. **Specific heat of liquids.**—The specific heat of liquids may be determined either by the method of cooling, by that of the ice calorimeter, or by that of mixtures. In the last-named case they are contained in a small metal vessel, or a glass tube, which is placed in the central compartment (fig. 430), and the experiment then made in the usual manner.

A method devised by Pfaundler of determining the specific heat of liquids, which under certain circumstances is advantageous, depends on the fact that an electric current heats any conductor through which it passes.

In two equal calorimeters containing the liquids to be tested, together with suitable thermometers and stirrers, two equal spirals of fine platinum wire are placed. These being connected in series with a voltaic battery by means of copper wires, the heat produced in the wires by the current will be equal, and the rise in temperature in the liquids will then be inversely as the specific heats. One of the liquids is usually water.

It will be seen from the table in the following article that water and a few other liquids have a high specific heat in comparison with metals and some non-metallic substances. From its great specific heat water requires a relatively long time in being heated or cooled through a given range of temperature, and for the same weight and temperature-range it absorbs or gives out far more heat than other substances. This double property is applied in heating apparatus of various kinds, and plays a most important part in the economy of nature.

463. **Specific heats of bodies.**—The list contained in the next article (464) gives the specific heats of a great number of elementary substances. We give here the specific heats of a few substances, mostly liquids :—

	Specific heat		Specific heat
Alcohol	0·620	Carbon bisulphide	0·245
Glycerine	0·555	Thermometer glass	0·198
Ether	0·516	Steel	0·118
Turpentine	0·426	Brass	0·094

According to Dewar (Presidential address, British Association, 1902) liquid hydrogen has a specific heat six times as great, and liquid air half as great, as that of water.

The specific heat of water is commonly taken at unity, which is not strictly correct. According to recent determinations the *mean* specific heat between 0° and t is expressed by the formula $1 + 0\cdot00015t$.

These numbers, as well as those in 464, represent the mean specific heats between 0° and 100° . It was shown by Dulong and Petit that the specific heats increase with the temperature. Those of the metals, for instance, are greater between 100° and 200° than between 0° and 100° , and are still greater between 200° and 300° ; that is to say, a greater amount of heat is required to raise a body from 200° to 250° than from 100° to 150° , and still more than from 0° to 50° . For silver the mean specific heat between 0° and 100° is $0\cdot057$, while between 0° and 200° it is $0\cdot0611$. The following table gives the specific heats at various temperatures :—

Copper	$0\cdot0910 + 0\cdot000046t$
Zinc	$0\cdot0865 + 0\cdot000088t$
Lead	$0\cdot0286 + 0\cdot000038t$
Platinum	$0\cdot0317 + 0\cdot0000062t$
Water	$1 + 0\cdot00015t$

The increase of specific heat with the temperature is greater as bodies are nearer their fusing point. Any action which increases the density and molecular aggregation of a body diminishes its specific heat. Thus hard

steel with the density 7·798 has the specific heat 0·1175 ; while that of soft steel of density 7·861 is 0·1165. The specific heat of copper is diminished by its being hammered, but it regains its original value after the metal has been again heated.

The specific heat of a liquid increases with the temperature much more rapidly than that of a solid. H. T. Barnes has shown that the specific heat of water is a minimum at about 40° C. (see art. 506). If we take its value at 16° as unity, the mean value between 0° and 100° is 1·00012, that is practically the same as at 16°.

The most remarkable examples of the influence of temperature on the specific heat are afforded by carbon, boron, and silicon. H. F. Weber found that at 600° the specific heat of carbon is 7 times, and that of boron 2½ times, as great as their respective specific heats at -50°. The specific heat of diamond is 0·0635 at -50°, 0·1318 at 33°, 0·2218 at 140°, and 0·3026 at 247°. Although the specific heat increases thus rapidly between -50° and 250°, beyond that point the rate of increase is slower ; and beyond 600°, or at an incipient red heat, it seems to be pretty constant, or at any rate to exhibit no greater variations with the temperature than are afforded by other substances. Thus while at 600° the specific heat is 0·441, at 985° it is 0·459. Graphite also has at 22° the specific heat 0·168 ; this increases, but at a gradually diminishing rate, to 642°, where its specific heat is 0·445. Like diamond, an incipient red heat seems to be a limiting temperature beyond which graphite exhibits only the ordinary variation with the temperature. Weber has also found that, in their thermal deportment, there are only two essentially different modifications of carbon—the transparent one (diamond), and the opaque ones (graphite, dense amorphous carbon, and porous amorphous carbon).

Crystallised boron is similar in its deportment to carbon ; its specific heat increases from 0·1915 at -40° to 0·2382 at 27°, and to 0·3663 at 233°. The rate of increase is very rapid up to 80° ; it increases beyond that temperature, but at a gradually diminished rate, and, no doubt, tends to an almost constant value of 0·5.

The specific heat of silicon also varies with the temperature ; between -40° and 200° it increases from 0·136 to 0·203 ; the rate of increase is less rapid with higher temperatures, being at 200° only one-fourteenth what it is at 10°. At 200° it reaches its limiting value.

The specific heat of substances is greater in the liquid than in the solid state, as will be seen by the following table :—

	Solid	Liquid
Water	0·502	1·000
Sulphur	0·203	0·234
Bromine	0·084	0·110
Iodine	0·054	0·080
Mercury	0·031	0·033
Phosphorus	0·190	0·212
Tin	0·056	0·064
Lead	0·031	0·040

It also differs with the *allotropic* modification ; thus, at ordinary temperatures, the specific heat of red phosphorus is 0·19, and that of white 0·17 ;

of crystallised arsenic 0.083, and of amorphous 0.058; of crystallised selenium 0.084, and of amorphous 0.095; of wood charcoal 0.241; of graphite 0.202; and of diamond 0.147.

Pouillet used the specific heat of platinum for measuring high temperatures. Supposing 200 ounces of platinum had been heated in a furnace and had then been placed in 1000 ounces of water, the temperature of which it had raised from 13° to 20°. From the formula we have $M = 200$, $m = 1000$; θ is 20, and t is 13. The specific heat of platinum is 0.033, and we have therefore, from the equation,

$$T = \frac{m(\theta - t) + Mc\theta}{Mc} = \frac{7000 + 132}{6.6} = \frac{7132}{6.6} = 1080^\circ.$$

It is found, however, that the mean specific heat of platinum at temperatures up to about 1200° is 0.0377; if this value, therefore, be substituted for c in the equation, we have

$$T = \frac{7150.8}{7.54} = 948^\circ \text{ C.}$$

By this method, which requires great skill in the experimenter, Pouillet determined a series of high temperatures. He found, for example, the temperature of melting iron to be 1500° to 1600° C.

464. **Dulong and Petit's law.**—A knowledge of the specific heat of bodies became of great importance in consequence of Dulong and Petit's discovery of the remarkable law, that the product of the specific heat of any solid element into its atomic weight is approximately a constant number, as will be seen from the following table:—

	Specific heat	Atomic weight	Atomic heat
Aluminium	0.2143	27.4	5.87
Antimony	0.0513	122	6.26
Arsenic	0.0822	75	6.17
Bismuth	0.0308	210	6.47
Bromine	0.0843	80	6.74
Cadmium	0.0567	112	6.35
Cobalt	0.1067	58.7	6.26
Copper	0.0939	63.5	5.99
Gold	0.0324	197	6.38
Iodine	0.0541	127	6.87
Iron	0.1138	56	6.37
Lead	0.0314	207	6.50
Magnesium	0.2475	24	5.94
Mercury	0.0332	200	6.64
Nickel	0.1092	58.7	6.41
Phosphorus	0.1740	31	5.39
Platinum	0.0324	197.5	6.40
Potassium	0.1655	39.1	6.47
Silver	0.0570	108	6.16
Sulphur	0.1780	32	5.70
Tin	0.0555	118	6.55
Zinc	0.0950	65.2	6.23

It will be seen that the number is not a constant, but varies between 5·39 and 6·87. These variations may depend partly on the difficulty of getting the elements in a state of perfect purity, and partly on errors incidental to the determination of the specific heats, and of the atomic weights. Again, the specific heats of bodies vary with the state of aggregation of the bodies, and also with the temperatures at which they are determined; some, such as potassium, have been determined at temperatures very near their fusing points; others, like platinum, at temperatures much removed from them. A prominent cause, therefore, of the discrepancies is doubtless to be found in the fact that all the determinations have not been made under corresponding physical conditions.

The specific heats of the non-metallic elements at ordinary temperatures do not conform to the law of Dulong and Petit. Thus, the specific heat of carbon (graphite) at atmospheric temperature is ·168, and its atomic heat 2·016; but at high temperatures the specific heat rises to and remains approximately constant at 0·46 (463), giving an atomic heat of 5·52, which approximates to the value found for metallic elements. The results obtained with boron and silicon show a similar agreement with the law.

The atomic weights of the elements represent the relative weights of equal numbers of atoms of these bodies, and the product, ρc , of the specific heat, c , into the atomic weight, ρ , is the *atomic heat*, or the quantity of heat necessary to raise the temperature of the same number of atoms of different substances by one degree; and Dulong and Petit's law may be thus expressed: *the same quantity of heat is needed to heat an atom of all simple bodies to the same extent.*

The atomic heat of a body, when divided by its specific heat, gives the atomic weight of a body. Regnault proposed to use this relation as a means of determining the atomic weight, and it certainly is of great service in deciding on the atomic weight of a body in cases where the chemical relations permit a choice between two or more numbers.

On modern views, the heat imparted to a body is partly expended in external work ($= P\upsilon$, where P is atmospheric pressure and υ the expansion), which in the case of a solid would be extremely small; secondly, the internal work, or the heat used in overcoming the attraction of the atoms for each other, and forcing them apart; and thirdly, there is the *true specific heat*, or the heat applied in increasing the temperature—that is, in increasing the energy of the molecules (453). By far the most considerable of these is the last; the amount of heat consumed in the two former operations is small, and the variations with different bodies must be inconsiderable. Until, however, the relation between the various factors is made out, absolute identity in the numbers for the atomic heat cannot be expected. Weber holds that even when due allowance has been made for these circumstances, the variations are too great to be accounted for, and he considers that they point for their explanation to an alteration in the constitution of the atom, and render probable a changing *valency* of the atom of carbon.

465. **Specific heat of compound bodies.**—In compound bodies the law of Dulong and Petit also prevails: the product of the specific heat into the equivalent is an almost constant number, which varies, however, with

different classes of bodies. Thus, for the class of oxides of the general formula RO , it is 11.30; for the sesquioxides R_2O_3 it is 27.15; for the sulphides RS , it is 18.88; and for the carbonates RCO_3 , it is 21.54. The law, which is known as *Neumann's law*, may be expressed in the following general manner:—*With compounds of the same formula, and of a similar chemical constitution, the product of the molecular weight into the specific heat is a constant quantity.* This includes Dulong and Petit's law as a particular case.

Kopp propounded the following law, which is an extension of that of Neumann:—*The molecular heats of all solid bodies are equal to the sum of the molecular heats of the elements contained in them.* Dulong and Petit's law that all elements have the same atomic heat he does not consider universally valid. He assigns the number 6.4 to all elements excepting the following: with sulphur and phosphorus it is 5.4, fluorine 5.0, oxygen 4.0, silicon 3.8, boron 2.7, hydrogen 2.3, and carbon 1.8.

Even with this modification it is found that the calculated heats of compounds differ more from the observed ones than can be ascribed to errors in the determination of the specific heats. This is probably due to the fact that some of the heat is expended in internal work, and that it is this which brings about the discrepancies.

With mixtures of alcohol and water in certain proportions, the specific heat is greater than that of the water; thus, that of a mixture containing 20 per cent. of alcohol was found by Dupré and Page to be 1.0456. No general law can be laid down for solutions of acids or of salts in water; the specific heat is most frequently less than that calculated from the constituents.

466. **Specific heat of gases.**—The specific heat of a gas may be referred either to that of water or to that of air. In the former case it represents the quantity of heat necessary to raise a given *mass* of the gas through one degree, as compared with the heat necessary to raise the same *mass* of water one degree. In the latter case it represents the quantity of heat necessary to raise a given *volume* of the gas through one degree, compared with the quantity necessary for the same *volume* of air treated in the same manner.

De la Roche and Berard determined the specific heats of gases in reference to water by causing known volumes of a given gas under constant pressure, and at a given temperature, to pass through a spiral glass tube placed in water. From the increase in temperature of this water, and from the other data, the specific heat was determined by a calculation analogous to that given under the method of mixtures. They also determined the specific heats of different gases relatively to that of air, by comparing the quantities of heat which equal volumes of a given gas, and of air at the same pressure and temperature, imparted to equal weights of water. Subsequently to these researches, De la Rive and Marcet applied the method of cooling to the same determination; and Regnault made a series of investigations on the calorific capacities of gases and vapours, in which he adopted, but with material improvements, the method of De la Roche and Berard. Fig. 433 represents this apparatus. The gas issues from a gas-holder, not shown in the figure, through the tube *a*, and enters the heating space *E*, which is filled with oil; the gas passes here through a serpentine tube, and

thus acquires the temperature of the oil, which is kept uniform by a stirrer, D. From this it passes into the calorimeter, W, which consists of a metal box divided into a series of compartments, and forming in effect a serpentine, so that the gas has to traverse a long path before emerging into the air. The temperature of this bath is indicated by a delicate thermometer, and is kept uniform by moving the stirrer. The pressure of the gas is noted on a manometer. Regnault thus obtained the following results for the specific

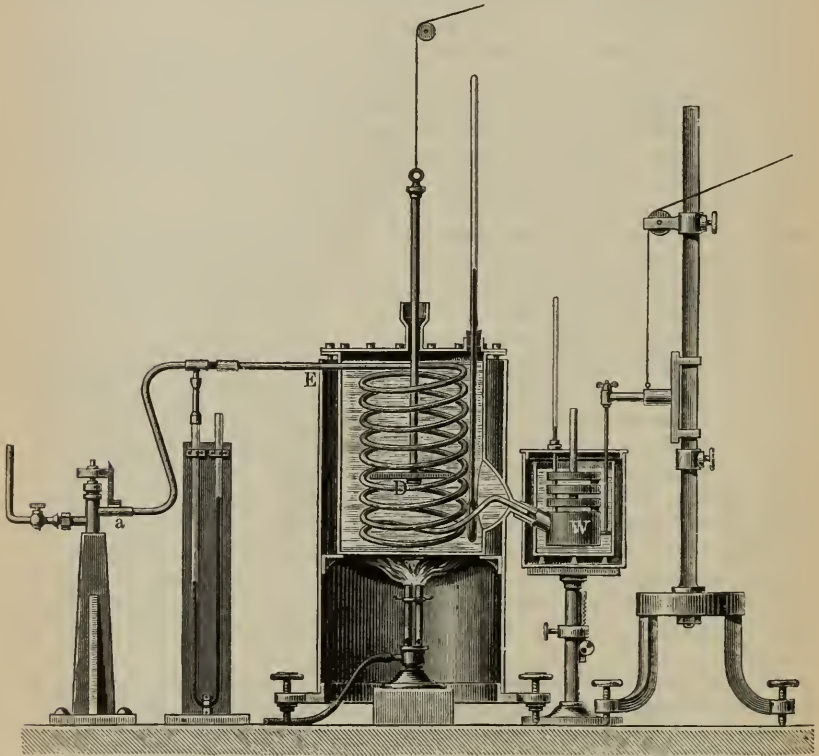

Fig. 433

heats of the various gases and vapours, compared first with the specific heat of an equal mass of water taken as unity ; secondly, with that of an equal volume of air, referred, as before, to its own mass of water taken as unity :—

		Specific heats	
		Equal masses	Equal volumes
	Air	0·2374	0·2374
Simple gases	{ Oxygen	0·2174	0·2405
	{ Nitrogen	0·2438	0·2370
	{ Hydrogen	3·4090	0·2359
	{ Chlorine	0·1210	0·2962

		Specific heats	
		Equal masses	Equal volumes
Compound gases	Nitric oxide	0·2315	0·2406
	Carbonic oxide	0·2450	0·2370
	Carbonic acid	0·2163	0·3307
	Hydrochloric acid.	0·1845	0·2333
	Ammonia	0·5083	0·2966
	Ethylene	0·4040	0·4106
Vapours	Water	0·4805	0·2984
	Ether	0·4810	1·2296
	Alcohol	0·4534	0·7171
	Turpentine	0·5061	2·3776
	Carbon bisulphide	0·1570	0·4140
	Benzole	0·3754	1·0114

In making these determinations the gases were under a constant pressure, but variable volume; that is, the gas as it was heated could expand, and this is called the *specific heat under constant pressure*. But if the gas when being heated is kept at a constant volume, its pressure or elastic force then necessarily increasing, it has a different capacity for heat; this latter is spoken of as the *specific heat under constant volume*. That this latter is less than the former is evident from the following considerations:—

Suppose a given quantity of gas to have had its temperature raised t° while the pressure remained constant, this increase of temperature will have been accompanied by a certain increase in volume. Supposing now that the gas is so compressed as to restore it to its original volume, the result of this compression will be to raise its temperature again to a certain extent, say t'° . The gas will now be in the same condition as if it had been heated and had not been allowed to expand. Hence the same quantity of heat which is required to raise the temperature of a given mass of gas t° , while the pressure remains constant and the volume alters, will raise the temperature $t + t'$ degrees if it is kept at a constant volume but variable pressure. The specific heat, therefore, of a gas at constant pressure, C_p , is greater than the specific heat under constant volume, C_v , and they are to each other as $t + t' : t$, that is $C_p/C_v = (t + t')/t$.

The value of the ratio C_p/C_v for any gas may be obtained from determinations of the velocity of sound in the gas (231). In the case of air this ratio is 1·41, and consequently, since $C_p = 0·2374$, $C_v = 0·2374/1·41 = 0·1663$. For monatomic gases, such as mercury vapour and argon, $C_p/C_v = 5/3 = 1·66$; for oxygen, nitrogen, and hydrogen 1·41, for carbon dioxide 1·31, and for ether vapour 1·03.

Professor Joly succeeded in measuring directly the specific heat of air and some other gases, at constant volume, by the condensation method described in art. 461. In this case the chamber A was large enough to contain two copper globes of equal size and weight which were suspended one from each arm of the balance. One of these globes was as far as possible exhausted and the other filled with the gas at a pressure of 20 or 30 atmospheres. When steam was admitted the amount of condensation on the gas-filled globe was greater than on the other, and from the weight required to

produce equilibrium the specific heat of the gas at constant volume was obtained. Joly found for air $C_v = \cdot 1721$, for carbon monoxide $\cdot 1730$.

Elementary gases do not obey Dulong and Petit's law. Dewar has, however, shown that, at the temperature of liquid air, the specific heat of hydrogen is 6, and of nitrogen $\cdot 43$, so that their atomic heats are respectively $6 \times 1 = 6$ and $\cdot 43 \times 14 = 6\cdot 02$, and thus at this low temperature are in agreement with the law.

467. **Latent heat of fusion.**—Black was the first to observe that during the passage of a body from the solid to the liquid state a quantity of heat disappears, so far as thermometric effects are concerned, and is accordingly said to become latent.

In one experiment he suspended in the room at a temperature $8\cdot 5^\circ$ two glass flasks, one containing water at 0° , and the other the same weight of ice at 0° . After half an hour the temperature of the water had risen 4° , that of the ice being unchanged, and it was $10\frac{1}{2}$ hours before the ice had melted and attained the same temperature. Now the temperature of the room remained constant, and it must be concluded that both vessels received the same amount of heat in the same time. Hence 21 times as much heat was required to melt the ice and raise it to 4° as was sufficient to raise the same weight of water through 4° . So that the total quantity of heat imparted to the ice was $21 \times 4 = 84$; and as only 4 of this was used in raising the temperature, the remainder, 80, was used in simply melting the ice.

He also determined the latent heat by immersing 119 parts of ice at 0° in 135 parts of water at $87\cdot 7^\circ$ C. He thus obtained 254 parts of water at $11\cdot 6^\circ$ C. Taking into account the heat received by the vessel in which the liquid was placed, he obtained the number 79·44 as the latent heat of liquefaction of ice.

The method which Black adopted is essentially that which is now used for the determination of latent heats of liquids; it consists in placing the substance under examination at a known temperature in the water (or other liquid) of a calorimeter, the temperature of which is sufficient to melt the substance if it is solid, or to solidify it if liquid; and when uniformity of temperature is established in the calorimeter, this temperature is determined. Thus, to take a simple case, suppose it is required to determine the latent heat of fusion of ice. Let M be a certain weight of ice at zero, and m a weight of water at t° sufficient to melt the ice. The ice is immersed in the water, and as soon as it has melted, the final temperature θ° is noted. The water and calorimeter, in cooling from t° to θ° , have parted with a quantity of heat, $(m + \mu)(t - \theta)$, where μ is the water equivalent of the calorimeter. If x is the latent heat of water, the ice absorbs, in liquefying, a quantity of heat Mx ; but, besides this, the water which it forms has risen to the temperature θ° , and to do so has required a quantity of heat, represented by $M\theta$. We thus get the equation

$$Mx + M\theta = (m + \mu)(t - \theta),$$

from which the value x is deduced.

By this method Desains and De la Provostaye found that the latent heat of the liquefaction of ice is 79·25; that is, a pound of ice in liquefying absorbs the quantity of heat which would be necessary to raise 79·25 pounds

of water 1°, or, what is the same thing, one pound of water from zero to 79·25°. Bunsen's latest determination gave 80·025 (456).

This method is thus essentially that of the method of mixtures ; the same apparatus may be used, and the same precautions are required, in the two cases. In determining the latent heat of liquefaction of most solids, the different specific heats of the substance in the solid and in the liquid state require to be taken into account. In such a case, let m be the weight of the water in the calorimeter (the water equivalents of the calorimeter and thermometer, supposed to be included) ; M the weight of the substance worked with ; t the original and θ the final temperature of the calorimeter ; T the original temperature of the substance ; \mathfrak{C} its melting (or freezing) point ; C the specific heat of the substance in the solid state between the temperature \mathfrak{C} and θ ; c its specific heat in the liquid state between the temperatures T and \mathfrak{C} ; and let L be the latent heat sought.

If the experiment is made on a melted substance which gives out heat to the calorimeter and is thereby solidified (it is taken for granted that a body gives out as much heat in solidifying as it absorbs in liquefying), it is plain that the quantity of heat absorbed by the calorimeter, $m(\theta - t)$, is made up of three parts : first, the heat lost by the substance in cooling from its original temperature T to the solidifying point \mathfrak{C} ; secondly, the heat given out in solidification, ML ; and, thirdly, the heat it loses in sinking from its solidifying point \mathfrak{C} to the temperature of the water of the calorimeter. That is :

$$m(\theta - t) = M \left[(T - \mathfrak{C})c + L + (\mathfrak{C} - \theta)C \right]$$

whence
$$L = \frac{m(\theta - t)}{M} - (T - \mathfrak{C})c - (\mathfrak{C} - \theta)C.$$

The following numbers have been obtained for the latent heats of fusion of the substances specified :—

Water	80·03	Tin	14·25
Sodium nitrate	62·97	Cadmium	13·66
Potassium nitrate	47·37	Bismuth	12·64
Zinc	28·13	Sulphur	9·37
Platinum	27·18	Lead	5·37
Silver	21·07	Phosphorus	5·03
Mercury	2·83		

The potential energy which bodies acquire in the act of melting is strictly comparable to that gained by a weight when work has been spent in raising it. When the liquid solidifies, it reproduces the heat which had been expended in liquefying the solid : just as when a stone falls it produces by its impact against the ground the heat, the equivalent of which in work had been expended in raising it, and a similar explanation applies to the latent heat of vaporisation.

468. **Determination of the latent heat of vapour.**—Liquids, as we have seen, in passing into the state of vapour, absorb a very considerable quantity of heat, which is termed their *latent heat of vaporisation*. In determining the heat absorbed in vapours, it is assumed that a vapour in

liquefying gives out as much heat as the liquid had absorbed in becoming converted into vapour.

The method employed is essentially the same as that for determining the specific heat of gases. Fig. 434 represents the apparatus used by

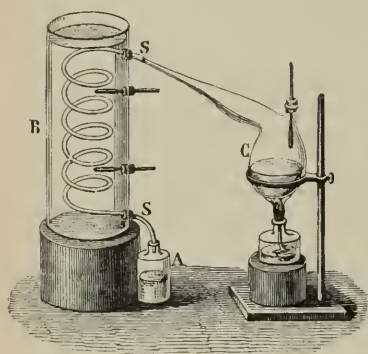

Fig. 434

Despretz. The vapour is produced in a retort, C, where its temperature is indicated by a thermometer. It passes into a worm, SS, immersed in cold water, where it condenses, imparting its latent heat to the condensing water in the vessel B. The condensed vapour is collected in a vessel, A, and its weight represents the quantity of vapour which has passed through the worm. The thermometers in B give the change of temperature.

Let M be the weight of the condensed vapour, T its temperature on entering the worm, which is that of its boiling point, and x the latent heat

of vaporisation. Similarly, let m be the weight of the condensing water (comprising the weight of the vessel B and of the worm SS reduced to their equivalent in water), let t° be the temperature of the water at the beginning, and θ° its temperature at the end of the experiment.

It is to be observed that, at the commencement of the experiment, the condensed vapour passes out at the temperature t° , while at the conclusion its temperature is θ° ; we may, however, assume that its mean temperature during the experiment is $\frac{(t + \theta)}{2}$. The vapour M after condensation has

therefore parted with a quantity of heat $M\left(T - \frac{t + \theta}{2}\right)c$, while the heat disengaged in liquefaction is represented by Mx . The quantity of heat absorbed by the cold water, the worm, and the vessel is $m(\theta - t)$. Hence

$$Mx + M\left(T - \frac{t + \theta}{2}\right)c = m(\theta - t),$$

from which x is obtained. Despretz found that the latent heat of steam at 100° is 540; that is, a pound of water at 100° absorbs in vaporising as much heat as would raise 540 pounds of water through 1° . The values for the latent heat of aqueous vapour obtained by Regnault at temperatures between 65° and 100° , and more recently by Dieterici at 0° , and by E. H. Griffiths at intermediate temperatures, are represented with great accuracy by the formula

$$L = 596.73 - 0.601 t.$$

Thus, at 100° , $L = 536.63$.

Bertholet used the apparatus represented in fig. 435 for determining latent heats of vaporisation. The liquid in the flask D is heated by the ring burner B, and the vapour which forms passes through the tube ab into

the serpentine S, where it condenses and collects in the bulb R. These are contained in the calorimeter C, the top of which is closed by a wooden cover, HH, and a layer of felt, NN'; they cut off any heat from the flask D and from the burner B. As the serpentine SR can be detached from *ab*, it is easy to determine the weight of the distillate; from this, and from the rise in temperature of the water in the calorimeter, the latent heat can be readily calculated.

In the conversion of a body from the liquid into the gaseous state, as in the analogous process of fusion, as the temperature rises to that of boiling, one part of the heat is used in increasing the temperature and another in internal work. For vaporisation, the greater portion is consumed in the internal work of overcoming the reciprocal attraction of the particles of liquid, and in removing them to the far greater distances apart in which they exist in the gaseous state. In addition to this there is the external work—namely, that done against the external pressure, usually that of the atmosphere; and as the increase of volume in vaporisation is considerable, this is large. Vaporisation may take place without external work being done, as when it is effected *in vacuo*; but whether the evaporation is under a high or under a low pressure, on the surface of a liquid or in the interior, there is always a great consumption of heat in internal work.

469. **Latent heat of vaporisation of liquefied gases.**—Mathias has determined the heat of vaporisation of certain liquefied gases, and its variation with the temperature between 0° and 33° , by means of the apparatus represented in fig. 436.

The liquefied gas is contained in a cylindrical gilt copper reservoir R, capable of sustaining a pressure of over 100 atmospheres, and connected with a long narrow serpentine tube coiled round it. The whole is immersed in a calorimeter. The serpentine is soldered to a screw valve A, which by means of a junction and a copper tube identical with that round the reservoir is connected with another and larger screw valve B.

F is a glass flask containing sulphuric acid, and during the course of the experiment, while the liquefied gas is evaporating the sulphuric acid drops into the water of the calorimeter, care being taken to mix by means of the thermometer; in this way the temperature may be kept constant to within a few hundredths of a degree; the escape of the gas is regulated by the screw valve B, the regularity of the flow being ascertained by a wash bottle Z containing glycerine.

The loss in weight of R gives the weight of the liquid vaporised, and from the loss of weight of F the heat due to the dilution of the sulphuric acid can be calculated. These two furnish the data for calculating the heat of evaporation of the liquefied gas at the constant temperature t° . At ordinary

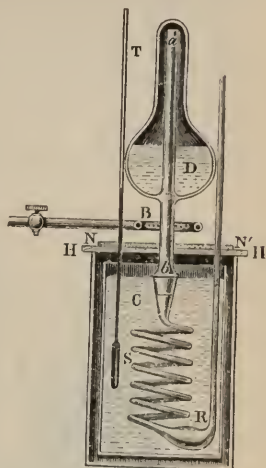

Fig. 435

temperatures the determination can be made between 0° and 22° ; beyond these limits special precautions are required.

Experiments were made with sulphurous acid, carbonic acid, and nitrous oxide; they show that the heat of evaporation constantly decreases, the decrease being linear for SO_2 , and extremely rapid for the other two gases.

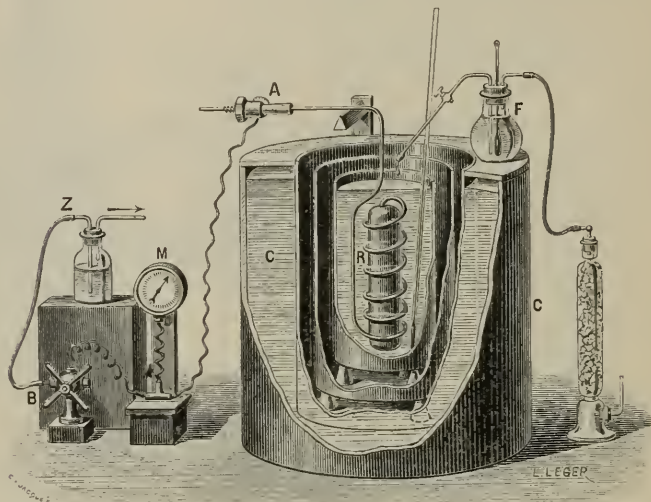

Fig. 436

The formula $\lambda = 117(31 - t) - 0.47(31 - t)^2$ gives the heat of evaporation of CO_2 from the critical temperature to temperatures much below 0° .

470. **Favre and Silbermann's calorimeter.**—The apparatus (fig. 437) furnishes a very delicate means of determining the calorific capacity of liquids, latent heats of evaporation, and the heat disengaged in chemical actions.

The principal part is a spherical iron reservoir, A, full of mercury, of which it holds about 50 pounds. On the left there are two tubulures, B, in which are fitted two sheet-iron tubes or *muffles*, projecting into the interior of the bulb. Each can be fitted with a glass tube for containing the substance experimented upon. In most cases one muffle and one glass tube are enough; the two are used when it is desired to compare the quantities of heat produced in two different operations. In a third vertical tubulure, C, there is also a muffle, which can be used for determining calorific capacities by Regnault's method (459), in which case it is placed beneath the opening *r* of fig. 430.

The tubulure *d* contains a steel piston; a rod turned by a handle, *m*, and provided with a screw thread, transmits a vertical motion to the piston, but, by a peculiar mechanism, gives it no rotatory motion. In the last tubulure is a glass bulb, *a*, in which is fitted a long capillary glass tube, *bo*, divided into parts of equal capacity.

The mercury calorimeter is thus essentially a thermometer with a very large bulb and a capillary stem: it is therefore extremely delicate. It differs, however, from a thermometer in the fact that the divisions do not indicate the temperature of the mercury in the bulb, but the number of thermal units imparted to it by the substances placed in the muffle.

This graduation is effected as follows:—By working the piston the mercury can be made to stop at any point of the tube *bo*, at which it is desired the graduation should commence. When a small quantity of mercury, which is not afterwards changed, is placed in the iron tube, a thin

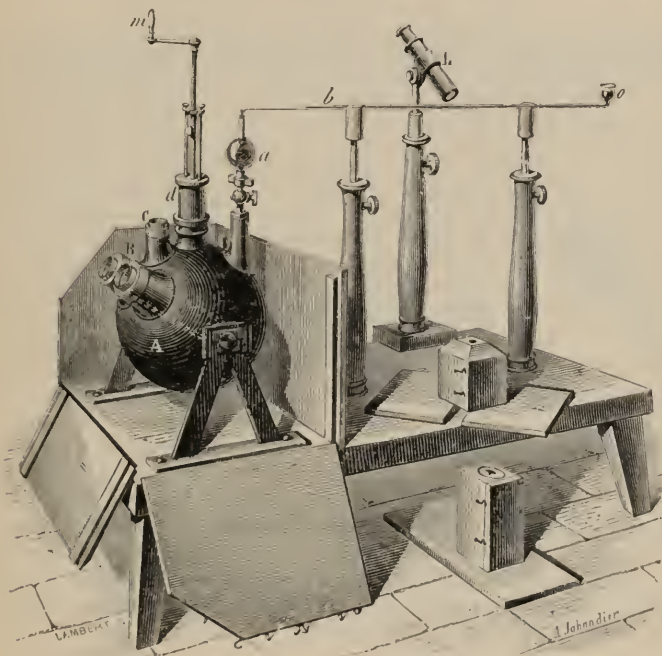

Fig. 137

glass test-tube, *e*, is inserted, which is kept fixed against the buoyancy of the mercury by a small wedge not represented in the figure. The tube being thus adjusted, the point of a bulb tube (see fig. 438) is introduced, containing water which is raised to the boiling point; on turning the pipette to the position *u'*, a quantity of the liquid flows into the test-tube.

The heat thus imparted to the mercury makes it expand; the column of mercury in *bo* is lengthened by a number of divisions, *n*. If the water poured into the test-glass is weighed, and if its temperature is taken when the column *bo* is stationary, the product of the weight of the water into the number of degrees through which it has fallen indicates the number of thermal units which the water has given up to the entire

apparatus. Dividing by n this number of thermal units, the quotient gives the number, a , of thermal units, corresponding to a single division of the tube bo .

In determining the specific heat of liquids, a given weight, M , of the liquid in question is raised to the temperature T , and is poured into the tube C . Calling the specific heat of the liquid c , its final temperature θ , and n the number of divisions by which the mercurial column bo has advanced, we have

$$Mc(T - \theta) = na, \text{ from which } c = \frac{na}{M(T - \theta)}.$$

The boards represented round the apparatus are hinged so as to form a box, which is lined with eider-down or wadding to prevent any loss of heat.

It is closed at the top by a board, which is provided with a suitable case, also lined, which fits over the tubulures d and a . A small magnifying glass, which slides along the latter, enables the divisions on the scale to be read off.

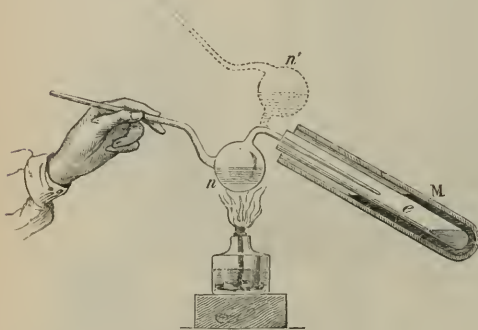

Fig. 438

471. **Examples.** — I.

What weight of ice at zero must be mixed with 9 pounds of water at 20° in order to cool it to 5° ?

Let M be the weight of ice necessary; in pass-

ing from the state of ice to that of water at zero, it will absorb $80M$ thermal units; and in order to raise it from zero to 5° , $5M$ thermal units will be needed. Hence the total heat which it absorbs is $80M + 5M = 85M$. On the other hand, the heat given up by the water in cooling from 20° to 5° is $9 \times (20 - 5) = 135$. Consequently

$$85M = 135; \text{ from which } M = 1.588 \text{ pounds.}$$

II. What weight of steam at 100° is necessary to raise the temperature of 208 pounds of water from 14° to 32° ?

Let p be the weight of the steam. The latent heat of steam is 540° , and consequently p pounds of steam in condensing into water give up a quantity of heat, $540p$, and form p pounds of water at 100° . But the temperature of the mixture is 32° , and therefore p gives up a further quantity of heat $p(100 - 32) = 68p$, for in this case c is unity. The 208 pounds of water in being heated from 14° to 32° absorb $208(32 - 14) = 3744$ units. Therefore

$$540p + 68p = 3744; \text{ from which } p = 6.158 \text{ pounds.}$$

CHAPTER X

STEAM AND OTHER HEAT ENGINES

472. **Steam-engines.**—Steam-engines are machines by which heat energy, obtained by the combustion of fuel, is turned into mechanical work ; aqueous vapour being used as a working fluid for effecting the transformation. In all but a very few exceptional cases the mechanical means used for the transformation of the one form of energy into the other are as follows : the heat of combustion is, as far as possible, imparted to water in a closed vessel called a *boiler* ; the water is there converted into steam of an enormously greater relative volume, and, the steam space being restricted, pressure is produced. This steam under pressure is allowed to pass from the boiler as fast as it is formed, and acts alternately on the two sides of a movable piston, with a to-and-fro motion, in a cylinder. As soon as the piston has been pressed to either end of the cylinder by the incoming steam acting on one side of it, the communication between that side and the boiler is closed, and another communication opened either to a condenser or to the atmosphere. In either case the steam escapes from the cylinder and the pressure against the piston drops, so that it can be pushed back by fresh steam from the boiler acting on the opposite side.

If the purpose of the engine is to drive pumps or other machines requiring a reciprocating motion only, a rod from the piston can be connected directly with the pump plunger. If, however, as in the majority of cases, a rotary motion is required, a simple mechanism, described in art. 474, converts the reciprocating motion of the piston into the rotary motion of a shaft. We will first consider the boiler, or apparatus for generating steam, and then the engine itself.

473. **The boiler.**—Figs. 439 and 440 show one of the forms of boiler commonly used for supplying steam to both land and marine engines. It is generally known as a multitubular water tank boiler from the prominent features of its construction. Fig. 439 shows a longitudinal section of the boiler, and fig. 440 a front view with the position of the most important mountings and the framing on which the boiler is supported.

The boiler consists of an outer cylindrical shell A of steel plate riveted together, and closed at the ends by flat plates, flanged at right angles at the circumference and riveted in place. The reason for adopting the cylindrical form is that it does not need to be stayed to enable it to stand internal pressure, but the end plates being flat have to be stayed to each other by long bar stays, B, with nuts on each side of the plates where they pass through. In the lower part of the front plate are fitted three tubes of large

diameter called *furnaces*, C; these are corrugated to withstand external pressure, and at the same time are thin enough to transmit the heat of the fire without becoming unduly heated. The inner ends of these furnace tubes are attached to three roughly rectangular chambers built up of steel plates and called *combustion chambers*, shown for the centre furnace in fig. 439 at D.

The combustion chambers, which are well stayed to each other and to the back of the boiler by screwed stays with nuts E, are connected with the

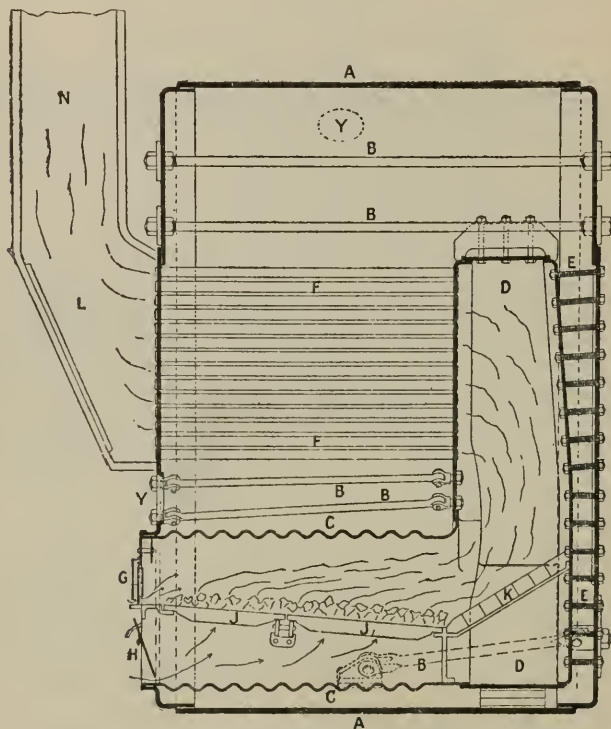

Fig. 439

front of the boiler by a large number of steel tubes, F, of small diameter, some of which are screwed into the plates to act as stays, and the others simply expanded lightly in the holes to make them pressure-tight.

The front of the furnace is closed by a thinner plate having two openings fitted with doors: the upper one, G, called the *furnace door*; the lower one, H, for the supply of air underneath the fire to aid the combustion, and called the *draught plate*.

The fuel is burnt on a grate J, formed by a series of fire-bars, terminating in a firebrick *bridge* K to deflect the gases or volatile constituents of the fuel which are distilled off into the combustion chamber, where they burn

completely. The hot products of combustion then pass through the small tubes, giving up their heat to the water and entering the *smoke box* L, which is a casing built over the openings of the tubes at the front of the boiler, and are carried from there through the *uptake* N to the chimney or funnel. In order to get as much heat as possible from these waste gases, the boiler feed

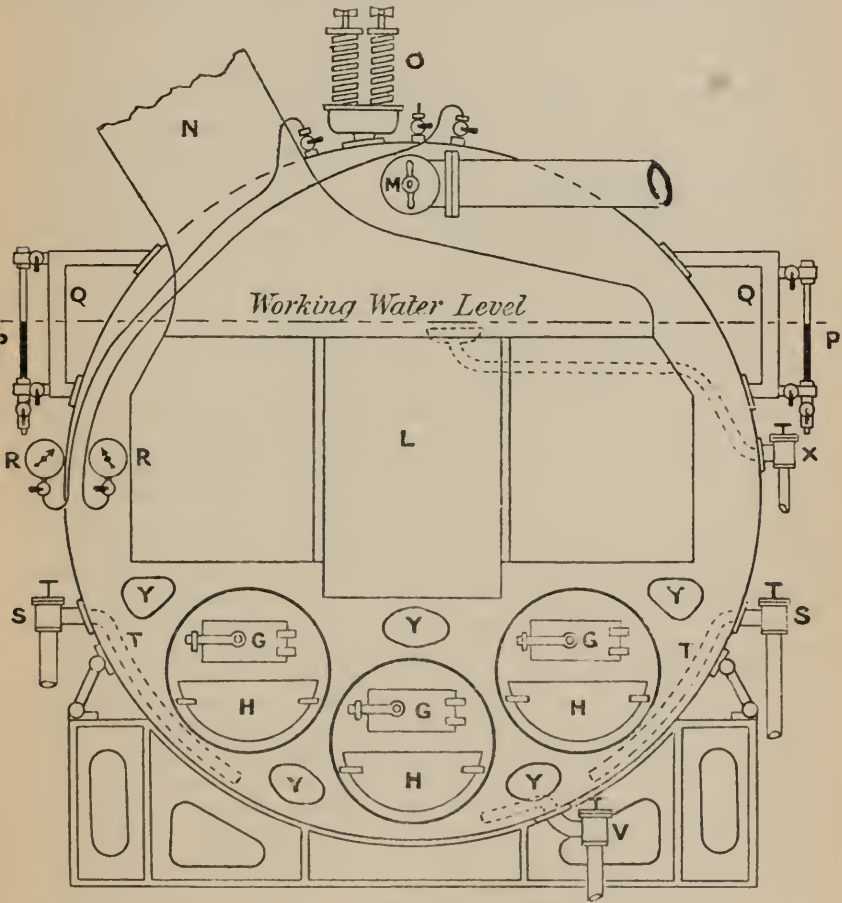

Fig. 440

water is sometimes carried through a series of small tubes placed in the uptake ; this fitting is called a *feed heater*.

The circulation of water in the boiler is roughly as follows : the feed water is pumped through a valve on the side of the boiler and by an internal pipe T (fig. 440) is discharged to the underside of the furnaces ; being thus heated convection currents are set up, and the water rises between the furnaces, tubes, and combustion chambers, which form the *heating surfaces*,

obtaining more heat on its way, and its place is taken by cooler water descending from the upper body of water ; these convection currents are maintained while the boiler is working. The working water level is kept at about 12 to 14 inches above the highest part of the heating surfaces, *i.e.* the top of the combustion chamber ; thus any of the plates in contact with the hot gases are prevented from overheating, which would reduce the strength of the metal. The space above the water level is called the *steam space*.

The principal fittings or mountings are indicated in fig. 440. M is a *stop valve* through which the steam supply to the engines is regulated, and is connected with an internal pipe into which the steam enters through a series of slots across its upper side ; this *internal steam pipe* assists in freeing the steam from any water which may be thrown up from the water surface by violent ebullition. O is a *safety valve* loaded by a spiral spring to the safe working pressure, and when the maximum pressure allowable in the boiler is reached, the valve lifts and allows the steam to escape into the atmosphere ; these valves are always fitted in duplicate to ensure safety. P is a *water gauge*, a glass tube held in fittings which are connected with a steady pipe Q, which itself is connected with the boiler a few feet above and below the working water level. The water stands in the glass at the same height as in the boiler, and the fireman can see at a glance if it is at the correct level. This fitting is of the highest importance, as a fall in water level sufficient to expose any part of the heating surface results in weakening, from overheating, of the plates at that part and a possible consequent collapse ; this has been the cause of many boiler accidents, and for this reason two water gauges are fitted, one on each side of the boiler. R, R are *pressure gauges* attached by small pipes to the top of the boiler. A pointer worked by a spiral tube inside the gauge indicates the boiler pressure, or the amount by which the pressure inside the boiler exceeds the atmospheric pressure. These also are fitted in duplicate. S, S are the *feed valves* by which the supply of feed water can be regulated. They are non-return valves, and thus allow the pump to force water into the boiler, but prevent the boiler pressure returning the water into the feed pipes and pump ; internal feed pipes, T, carry the water to the lower part of the boiler. The two valves fitted are for the discharge from two separate pumps, so that an extra pump is always ready in case the pump in use breaks down. V is a *running down valve* for emptying the boiler for cleaning purposes when not in use. X is a *scum valve* for clearing the surface of the water of any accumulation of grease. Y, Y are *manhole doors* by which access is obtained to the boiler interior, when empty, for cleaning purposes.

473A. **Water-tube boilers.**—The necessity for higher steam pressures to obtain increased economy of working brought the tank boiler to its limit, especially for marine purposes, as the increased weight due to making the parts sufficiently strong rendered it too heavy for the power obtained. This led to the introduction of a type known as water-tube boilers ; briefly the difference between this type and the water-tank boiler described above is, that the flames and water are interchanged, the water being contained in a series of small tubes connected to common collectors of cylindrical form, and the flames and hot gases are directed against and pass around

the outsides of the tubes. A large number of types of water-tube boilers have been introduced each claiming special advantages, but they all have the same general features in common.

(1) The tubes are connected with a common steam chamber above and water chamber or chambers below.

(2) The feed water is introduced into the steam chamber and descends by definite downtake tubes to the water chambers, there entering the small generating tubes; it is heated, and a mixture of steam and water rises in these tubes and is discharged into the steam chamber.

The points of advantage claimed for water-tube boilers over tank boilers may be summed up in the following:—

1. The tubes and collectors being of small diameter can be made strong enough to withstand high pressures without entailing too great a weight.

2. Owing to the small amount of water contained the boilers are lighter, and the effects of a fracture are less disastrous, than in the case of a tank boiler. This is of importance in warships.

3. High powers can be obtained owing to the large grate area and heating surface.

4. Repairs can be easily and quickly made, but the life of the water-tube boiler, taking into consideration its working at a higher rate, is rather less than that of the tank type.

Boilers of this character were first introduced early in the nineteenth century, but no great success was obtained, and only in 1879 the first of a type known as the Belleville boiler met with success. Since then the number of different types has greatly increased, and some are good steam generators.

It will be sufficient for the purpose to describe one particular type from which good results have been obtained in practice. Fig. 441 shows a half section and half front view of one of these boilers, which contains an upper steel cylinder or *steam collector*, and three lower steel cylinders or *water collectors*. The steam collector is connected with the centre water collector by a series of tubes of large diameter, A, and with the wing collectors by a single tube of slightly larger diameter, outside the boiler, one to each wing collector, B; these form the *downtake tubes*. A large number of curved tubes of small diameter are fitted between the upper and lower collectors, secured in holes in each by being expanded in place; these tubes form practically the entire heating surface. The whole is surrounded by a thin steel casing with openings at the front for furnace doors, draught plates and cleaning doors, and an opening at the top for the funnel. The fuel is carried on a series of fire-bars in the lower part of the boiler, and the ends of the furnace are protected from the flames by walls of firebrick.

In order to prevent the products of combustion passing direct between the tubes to the uptake without completely burning or giving up their heat, the gases are constrained to pass around the tubes, as shown by the arrows in the figure, by bending two adjacent rows of tubes until they are in the same plane, so forming a complete baffle; in the figure this is done at C, D, E, F. In this way the gaseous products have time to burn completely, and give up a large percentage of their heat to the tubes before passing away to the funnel.

A very important point is the circulation of the water, which must be good, as these boilers are of small capacity, and defective circulation would at once result in overheating. The feed water is pumped into the steam collector through a valve which is regulated automatically by a float in the water, and from this it flows down the downtake tubes, which are placed in positions to be shielded from the flames, to the water collectors; then entering the small tubes it is heated and partially evaporated, and the mixture of steam and water rises and is discharged into the steam collector,

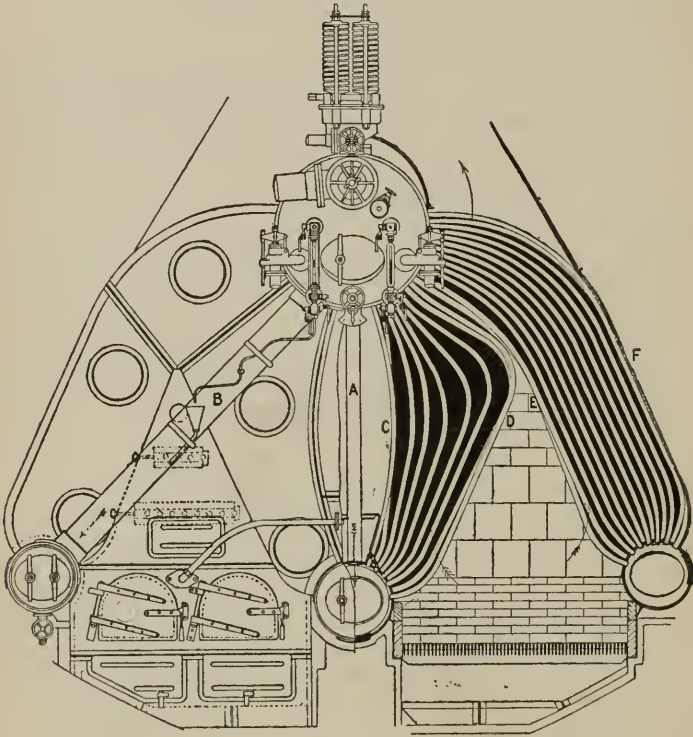

Fig. 441

whence the water continues on the same course; the steam filling the space above the water level is collected by an internal steam pipe and carried to the stop valve.

The fittings on this type of boiler are the same as those described in art. 473, and will be recognised in the figure.

474. **The steam-engine.**—The steam-engine of the present day is the result of the gradual improvement of those invented by Newcomen and Watt. These were originally reciprocating engines only, that is to say, the steam pressure was used to drive a piston to and fro in a cylinder, and the motion was transmitted through a piston-rod to work up and down one end

of a rocking lever, to the other end of which was connected a pump-rod, the whole being used for mine pumps. Later, by Watt, this reciprocating motion of the piston was converted into a continuous rotary motion by means of a crank and connecting rod. The admission and exhaust of steam alternately to and from either end of the cylinder being arranged for by a mechanism to be described (475), ensured a more or less continuously sustained effort resulting in a continuous rotation, which is the motion most generally required.

The steam, after it has done its work in driving the piston through its stroke, is exhausted or conveyed from the cylinder by a pipe to a *condenser*. This condenser consists of a casing containing a number of tubes of small diameter, held between the two flat ends or tube plates, holes being drilled in the tube plates in which the tubes fit tightly. Cold water is continually circulated through these tubes, and the exhaust steam from the engine is led to the inside of the casing, and coming in contact with the cold tubes is immediately condensed and is pumped away from the bottom of the casing by an *air-pump*. Due to the exhausting action of the air-pump and the condensation of the steam, a very low pressure of 2 to 3 pounds per square inch absolute (called usually a vacuum) is maintained in the case, which, as it is in connection with the cylinder, does not oppose the motion of the piston to any great extent.

Sometimes the exhaust steam is led direct to the atmosphere; in this case the engine is called *non-condensing*, and not only is the resulting water lost, but opposing the motion of the piston is a back pressure, to the extent of about 15 pounds per square inch absolute, or the atmospheric pressure at that place.

Fig. 442 shows in section the arrangement of the mechanism used to obtain the rotational motion. A is a large cylindrical iron casting called a *cylinder*. On account of the intricacy of this casting the cast iron used has to be of a soft quality to ensure it being fairly fluid when melted, so as to supply a good working surface for the piston. A plain cylindrical barrel or *liner* made of a harder material, B, is fitted inside, and held in place at the top and bottom. At the same time it forms, with the cylinder walls, an

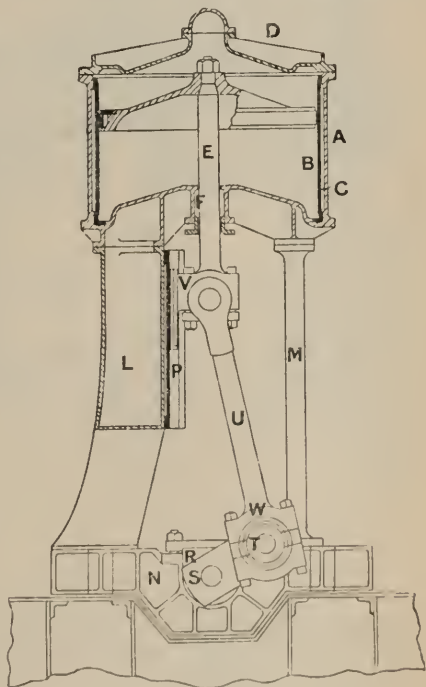

Fig. 442

enclosed annular space called a *steam jacket*, C, to which steam is admitted direct from the boiler, and, keeping the cylinder uniformly heated, prevents condensation of the working steam.

The top of the cylinder is closed by a *cylinder cover*, D, held down by a number of bolts around its circumference. The bottom is cast in one with the cylinder, an opening being allowed for the *piston-rod*, E, to work through. An annular space, F, is formed around the rod, which is filled with some kind of packing, to enable the piston-rod to work steam tight and with minimum friction; this is generally called the *stuffing-box*. There are two other openings in the cylinder, one at each end, connecting the ends with ports in the *valve face*, H (fig. 443), through passages formed in the casting.

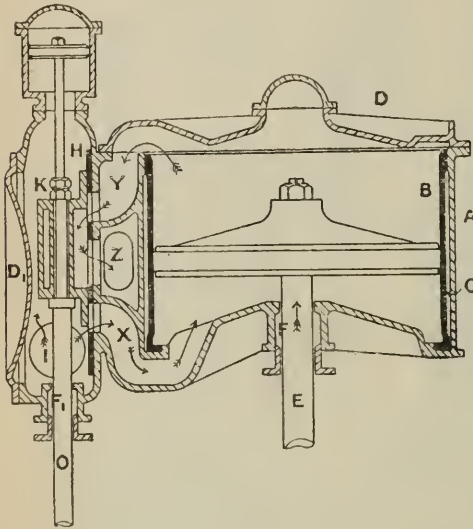

Fig. 443

This valve face is a plane on which the *slide valve*, K, works, regulating the alternate admission and exhaust of steam. The cylinder is supported by columns, L, M (fig. 442), on a framing, N, and a *guide*, P, is arranged on the column, L, on which the end of the piston-rod outside the cylinder works, thus constraining the rod to move in a straight line. *Bearings*, R, are fitted in the framing to hold the crank shaft, S, and to ensure its motion being purely rotational. The lower end of the piston-rod is connected to the crank pin, T, by a *connecting rod*, U, having bearings at both ends: the crosshead bearing,

V, to allow of a turning motion of small angle, and the crank-pin bearing, W, to allow of a complete rotation of the crank pin, which, being connected to the crank shaft by the crank arms, rotates with the shaft.

This type of engine, known as a vertical double-acting one, is largely used for the propulsion of ships by driving a screw propeller, and for driving shafting for factory machinery. Being vertical it is much more easy of access for good supervision and repair, also it takes up less floor space than if it were horizontal. Fig. 444 shows a type of horizontal engine frequently built for driving shafting, or working hydraulic pumps; in this latter case the pump is worked directly, the plunger-rod of the pump being connected to the engine crosshead. In fig. 444, F is a *governor* which controls the admission of steam to the engine slide valve, so maintaining a more or less constant speed though the load or resistance of the shaft be at times varied. This apparatus, an invention of James Watt, consists essentially of two weighted arms hinged at the top to a central spindle, and rotated by gearing

pressure of the steam expanding below it. By the time the piston has arrived at the top of its stroke the position of the valve is reversed from that shown in the figure, and the steam now passes into the cylinder by the top port pressing the piston down, while the steam which has already done duty in the lower end escapes, in its turn, through the exhaust port.

The eccentric, from which the valve receives its motion, is shown in fig. 445. Here A is the crank shaft, and B a disc or *sheave*, keyed (as seen at

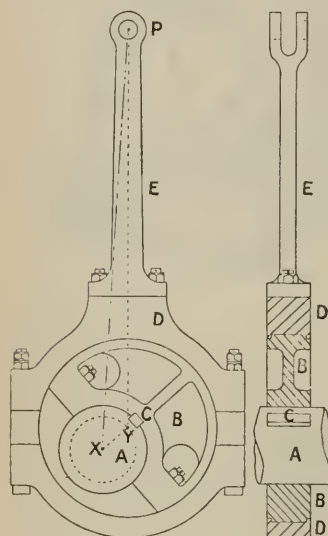

Fig. 445

C) eccentrically on it so as to revolve with it. Encircling this disc is a *strap* or bearing D, made in two pieces, rigidly connected with an *eccentric rod* E, which is coupled, by a pin P, to the valve-rod O (fig. 443). In each revolution of the eccentric disc the valve-rod is moved up and down through a space equal to twice the eccentricity of the eccentric, or the distance between the centres X and Y. The eccentric is thus equivalent to a crank having a radius equal to its eccentricity, the sheave B being the crank pin, and is used because the amount of travel of valve required is too small to allow of an ordinary crank being fitted.

In locomotives and marine engines two eccentrics are fitted, one so placed to give the valve the correct motion when the shaft is required to rotate in one direction, the other correctly fixed for the reverse direction of rotation. The upper ends of the eccentric rods are connected by a curved bar, called a *link-bar*, which can slide through a bearing formed in the end of the slide rod. By a mechanism, called *reversing gear*, either eccentric rod can be placed in line with the slide rod, so as to give the valve motion for the direction of rotation required. This reversing gear is shown in fig. 446 of the locomotive.

476. **Locomotives** are steam-engines which, mounted on a carriage, propel themselves by transmitting their motion to the wheels. The whole machine (fig. 446), boiler and engine, is fixed to a steel *frame* which carries the whole weight, and in turn transmits that weight to the *axle-boxes* (or bearings in which the *axles* turn) by means of springs, and thence through the wheels to the rails. The *boiler* is of a special type adopted in order to get the greatest possible heating surface in a very limited space, especially height and breadth. It is very similar to the boiler in art. 473, except that in this case the *shell* or barrel is of smaller diameter, and the furnace or *fire-box* is formed by a more or less rectangular box being riveted inside the rear end of the barrel, which at this place is also rectangular. The front end of the furnace has an opening for stoking closed by a furnace door. The back end of the fire-box is connected to the end of the boiler by a number of tubes of small diameter which pass through the water space.

The fuel is burnt on a grate formed of fire-bars, and the burning gases

and products of combustion are deflected by a firebrick bridge against the top of the fire-box, and thence through the tubes, giving up their heat to the surrounding water, passing thence to the *smoke-box*, which is a cylindrical casing attached to the front end of the boiler. The funnel is fitted on the upper side of this casing.

The water level in the boiler is kept at a height considerably above the top of the fire-box.

Half-way along the length of the boiler a *dome* is fitted on the boiler shell, from which the internal steam pipe is led; this dome ensures a supply of steam to the cylinders free from water. At the mouth of the pipe is fitted a valve, the function of which is to regulate the supply of steam to the engine, worked by a rod and handle from the footboard of the locomotive.

There are two steam cylinders of small diameter, one on each side of the frame, each with its piston, piston-rod, and connecting rod, as in an ordinary horizontal engine. The crank pins being fixed on one of the pairs of *driving wheels*, placed so that the cranks are at right angles, it follows that one will be exerting its maximum turning moment when the other is on its *dead point*, or the position in which the crank arm and connecting rod are in one straight line, when no *turning force* is exerted.

The eccentrics are keyed on to the axle of the same driving wheels, and work the slide valves by means of rocking levers. To put either the forward or backward eccentric into gear (475) the link is worked

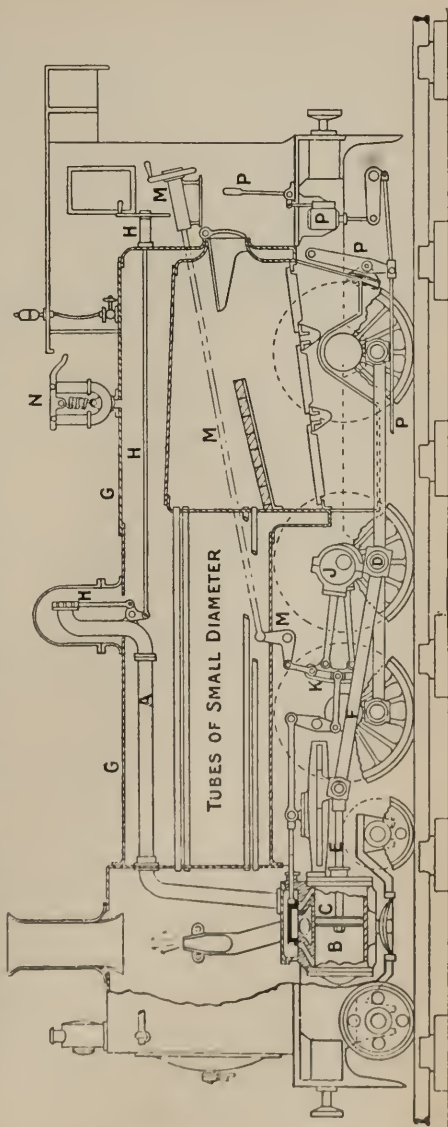

Fig. 446

by means of a rod and lever connected to a screw and wheel on the footboard.

The exhaust steam from each of the slide-valve cases is led to a common pipe terminating in a slight nozzle in the base of the funnel, called the *blast pipe*, and thus the escaping steam induces the fierce draught required in these boilers to ensure rapidity of combustion of the coal, and so develop a large amount of heat from the comparatively small fire-grate.

A locomotive such as that shown in the figure is called an *outside cylinder engine*, on account of the position of its cylinders. Many engines have cylinders placed inside the frames, which are then called *inside cylinder locomotives*. In express engines the cylinders frequently drive only one pair of very large wheels. These are called *driving wheels*, those on the front bogie being *leading wheels*, and on the rear axles *trailing wheels*. In many cases, however, especially in goods locomotives, where a greater tractive power is required, two or more pairs of wheels of the same diameter are connected together by *coupling rods*. Such engines are called *coupled engines*, the one shown in fig. 446 being a *six-coupled engine*, the cylinders actually driving the centre pair, which are connected by coupling rods to the other pairs.

To prevent slipping between the wheels and the rails, in which case the engine would not move forward, it is necessary to increase the friction between them. This is done by making the largest portion of the whole weight possible rest on the driving wheels, and when necessary by increasing the coefficient of friction (49) by pouring sand on the rails. All locomotives are furnished with sand-boxes, with pipes leading to the rails, for this purpose.

The following is an explanation of the reference letters in fig. 446 :— A is the internal steam pipe conveying steam from the dome to the cylinder B ; in this works a piston C, driving the crank D, by means of the piston and connecting rods E and F.

The boiler G is covered with non-conducting material which does not perish when heated (such as silicate cotton), and which is held in place by thin iron plating, this preventing radiation. HH is the arrangement for regulating the admission of steam to the slide-valve case. J, K are the eccentrics and link manipulated from the footboard by the shaft and wheel M. N the safety valve, PPP the brakes and gear for working them.

477. Expansion of steam. Bi- and Tri-compound engines.—With the increase in steam pressure available, due to better workmanship, materials, and design of boilers, greater advantage can be taken of the expansive property of steam. It was explained in art. 475 that, after the piston had traversed a portion of its stroke, the communication between the boiler and cylinder was cut off by the slide valve, and the remainder of the stroke was accomplished by the force due to the expansion of the steam.

In the case of higher-steam pressures, *e.g.* at the boiler 220 to 300 pounds per square inch by *gauge* (that is above normal atmospheric pressure), reduced to 200 to 250 pounds per square inch at the engines, and when the engine is fitted with a condenser in which a constant pressure of 5 pounds per square inch *absolute* (that is 10 pounds below normal atmospheric pressure, N.A.P., taken as 15 pounds per square inch absolute) is maintained, the steam

can expand doing work through a drop in pressure of 210 to 260 pounds per square inch. This expansion could be carried out in a single cylinder, but such an arrangement would be accompanied by the following faults:—

(1.) *Heat defect.*—The cylinder walls would be exposed alternately to the temperature of admission, viz. 406° F. (corresponding to 265 pounds per square inch absolute), and the temperature of exhaust, viz. 162° F. (corresponding to 5 pounds per square inch absolute). This latter so reduces the temperature of the metal of the cylinder, that when the first rush of steam comes into the cylinder at the beginning of the next stroke, a large quantity of the steam is immediately condensed, giving up its heat to the walls until they are raised to the higher limit of temperature. Hence a large amount of heat is used up, and a greater weight of steam required per stroke to make up for this initial condensation. Although during the expansion part of this condensed steam, which exists as a film of water on the walls, may re-evaporate, still some will remain in the form of water in corners and pockets during the exhaust stroke, and so will cause a more rapid condensation at the commencement of the next stroke.

(2.) *Mechanical defect.*—The cylinder would have to be very large to hold sufficient steam at its lowest pressure when its *specific volume* is great (specific volume briefly is the volume of unit mass of steam), and at the same time to be sufficiently strong to stand the high initial pressure. Hence it would be very heavy.

By employing two or more cylinders connected in series, and allowing the steam to expand in two or more *stages*, both these defects are overcome. Since the expansion is in stages, the range of temperature and pressure in one single cylinder is reduced. Hence the cooling effect in each cylinder is lessened. Also the first cylinder being of smaller dimensions, since the specific volume at high pressures is small, it can be made sufficiently strong without entailing too great a thickness, and thus saves weight.

For moderate initial pressures, *e.g.* 105 pounds per square inch absolute (corresponding temperature 330° F.), two cylinders are used called respectively the *high-pressure* and *low-pressure* cylinders. This is known as a *bi-compound* or two-stage expansion engine, and each cylinder would have a range of temperature of $(330^\circ - 162^\circ) \div 2 = 84^\circ$ F.

With higher initial pressures, *e.g.* 265 pounds per square inch absolute (corresponding temperature 406° F.), three cylinders would be used; this is known then as *tri-compound* or three-stage expansion, and each cylinder would have a range of temperature of 81° F. The range of temperature of 80° F. is considered the maximum that should be allowed in one particular cylinder. Each cylinder would in this case be complete with its own slide valve, &c., and all would be coupled to the same crank shaft, the cranks being set in the case of bi-compound engines at right angles, and tri-compound engines at 120° to each other. This system, besides enabling the engines to overcome the difficulty of the respective *dead points* (476), is also productive of a more uniform turning moment, which is very desirable.

In large slow-running engines the cylinder casting is fitted with an inner working barrel or liner, which forms with the casting an annular space. This space is kept filled with steam direct from the boiler, so keeping the cylinder warm and still further preventing cylinder condensa-

tion. Such an engine is said to be *steam-jacketed*, and though thermodynamically it is an inefficient way of applying heat, yet it is found to give good practical results with *slow-running* engines.

478. **Work of an engine. Horse-power.**—The unit of work by which the performance of an engine is measured is in this country always a foot-pound, the number of foot-pounds of work done in any given time being the product of the average effective pressure on the piston during that time, and the total distance through which the piston has moved under that pressure. By *average effective pressure* is meant the average value of the difference between the pressures on the two sides of the piston. Taking the time as one minute, this work would be given in foot-pounds by the following:—

Area of piston × *average intensity of effective pressure on the piston* × *the length of stroke* × *number of strokes per minute.*

The stroke must be taken in feet. If the area is in square inches, the pressure must be in pounds per square inch; if the area is in square feet, the pressure must be in pounds per square foot.

If the strokes are double strokes—each corresponding, that is, to one complete revolution of the shaft—the length of stroke must be multiplied by two, and the number of revolutions per minute can be measured. To find, for example, the work done per minute by an engine with a cylinder 16 inches diameter and 24 inches stroke, making 50 revolutions per minute with an average intensity of effective pressure of 52 pounds per square inch, we have

$$(3 \cdot 1416 \times 8^2) \times 52 \times \left(\frac{2 \times 24}{12} \right) \times 50 = 2,091,000 \text{ foot-pounds.}$$

The rate at which an engine does work is often measured in units called a *horse-power*, one horse-power being work done to the extent of 33,000 foot-pounds per minute, supposed to represent the maximum rate at which work could be done by a horse. In the case supposed the horse-power would be

$$\frac{2,091,000}{33,000} = 63 \cdot 4.$$

Steam-engines are used nowadays for the propulsion of large war-ships and ocean liners developing 30,000 to 50,000 horse-power.

On the Continent the unit of work is a kilogrammetre, which is very closely equal to 7·25 foot-pounds. The horse-power used abroad, of 75 kilogrammetres per second, is about 1½ per cent. smaller than that in use in this country.

479. **Indicator. Dynamometers.**—By the expression *work done by an engine*, we may mean either of two things, viz. the *total* work done by the steam in the engine, or the *useful* or *effective* work, which is that which could be taken off at the crank shaft. The total work is obtained by calculation, as described in the last article, and is usually called the indicated work or *indicated horse-power* (I.H.P.). The useful work is what remains of this total after a deduction has been made of the work necessary to overcome the frictional resistances of the bearings and other working parts, and is called the *brake horse-power* (B.H.P.).

The indicated work of an engine is measured by an instrument called an *indicator*, invented by Watt, of which fig. 447 shows one of the most recent

forms (McInnes'). The steam-engine indicator consists of a small cylinder, A, in which works a piston B, the under side of which can be put into communication with either end of the engine cylinder. Between the upper side of the piston and the under side of the cylinder cover is a spiral spring. The motion of the piston-rod is transmitted by a parallel motion, DD, and causes a point E to move up and down in a straight line, its stroke being about four times as great as that of the small piston. The indicator is fixed on a branch of a pipe connected to both ends of the cylinder, a directing cock being fitted at the branch by means of which either end of the cylinder may be put into communication with the indicator cylinder or both ends can be shut off; so that by opening the cock there is the same pressure of steam on the indicator piston as on the engine piston, whichever end of the cylinder it happens to be connected with. The pressure forces up the piston, and the amount of compression of the spring so caused is proportional to the pressure. The motion of E is therefore proportional to the steam pressure.

The motion of E is therefore proportional to the steam pressure. In front of E is a vertical drum F, on which a strip of paper can be fixed, and this drum is caused to rotate about its axis by a cord, G, which is attached to a suitable reciprocating part of the engine, the return motion of the drum being produced by a suitable spring in its base. The paper thus moves horizontally under the pencil, fixed at E with a motion proportional to the stroke of the engine, while the pencil moves up and down on the paper with a motion proportional to the steam pressure in the cylinder.

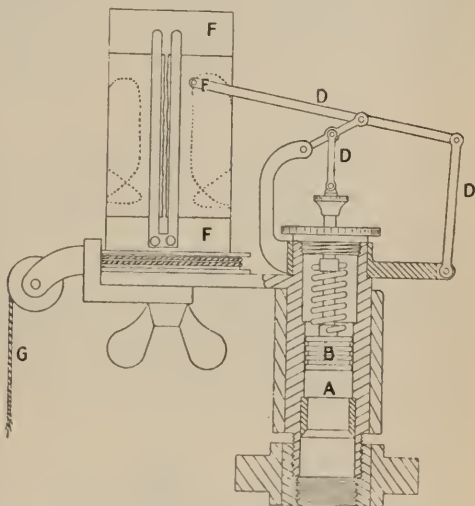

Fig. 447

The two motions occurring simultaneously, the pencil traces on the paper a curve whose horizontal and vertical ordinates are proportional to the two quantities just named, and whose area is therefore proportional to the product of these quantities, or, which is the same thing, to the work done by the steam in driving the piston against its various resistances, as defined in the last article.

The curve is called an *indicator diagram*, and while its *area* shows, on some scale depending on the strength of the spring and area of the indicator piston, the work done by the steam, its *form* shows the variation of steam pressure in the cylinder from point to point of the piston stroke, which is required to be known to investigate the working of the slide valve.

Figs. 448 and 449 show two forms of indicator diagrams. The curves themselves, as drawn by the indicator, are lettered ABCD and A'B'C'D', one

for each side of the piston. Beside them is a scale of pressures in pounds per square inch absolute, the horizontal line EF being drawn at a height representing atmospheric pressure, viz. 14.7 pounds per square inch absolute.

In fig. 448 the steam is expanded about seven times, and as the engine is a condensing one the back pressure is about 5 pounds, the pressure during admission being about 75 pounds. Fig. 449 is for a non-condensing engine, the back pressure being slightly above atmospheric; here the steam is cut off

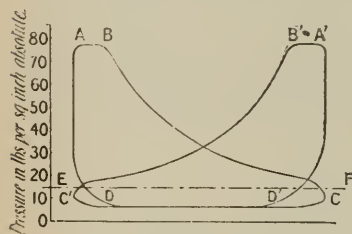

Fig. 448

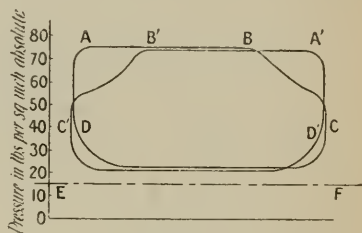

Fig. 449

at about $\frac{3}{4}$ of the stroke. The roundness of the corners of the diagrams is due to the fact that the slide valve does not give a sudden opening or closing to steam or exhaust, the gradual movement causing *wire-drawing* of the steam.

The *useful work* of an engine is measured by an entirely different mechanism, called a *dynamometer*. There are two types, the one to be used depending on the conditions under which the trial is made. If the engine can be used entirely for the purposes of the test an *absorption dynamometer* is used; while if the engine is required to carry on its ordinary work a *transmission dynamometer* is used.

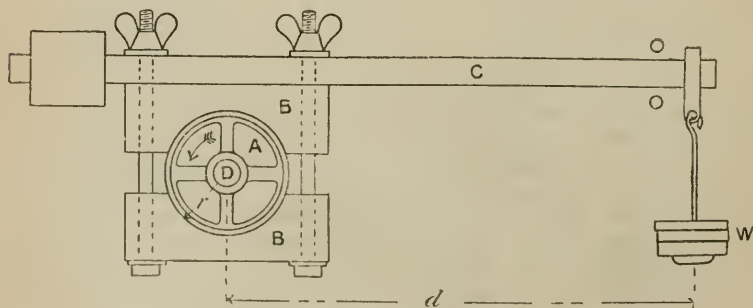

Fig. 450

Absorption dynamometers are of various forms, but fig. 450 shows the principle upon which the majority act. The apparatus shown in the figure is known as *Prony's friction brake*. A is a pulley attached to the engine shaft revolving between two blocks of wood, B and B, which can be tightened together around the pulley by means of the bolts and nuts shown. To the

upper block is fixed a lever C, from the end of which hangs a weight W, which measures the turning moment. Two stops are fitted, one above and one below the lever, to prevent it taking charge. When the shaft D revolves the nuts are tightened up just sufficiently to allow the frictional force between the pulley and the blocks to keep the beam or lever floating horizontally between the stops, and the weight, W, is adjusted and the screws tightened until the shaft revolves steadily at a definite number of revolutions, N, per minute. Now the moment of resistance to turning is $F r$, where r is the radius of the pulley and F the frictional force between it and the blocks. Since the lever C with the hanging weight is in equilibrium between the stops, the moment of the weight will be $W d$, where d is the distance between the point of application of the load and the vertical line through the centre of the pulley. Therefore, $F r = W d$.

The work done by the engine per minute is equal to the work absorbed by the brake, that is the frictional moment overcome multiplied by the distance through which it is overcome in one minute,

$$= F r \times 2\pi N = W d \times 2\pi N.$$

And reckoning in horse-power units, the useful work of the engine, called the

$$\text{Brake horse-power or B.H.P.} = \frac{W d \times 2\pi N}{33,000}.$$

As these quantities are all readily determined, the apparatus affords a simple method of measuring the net work transmitted by the engine shaft.

The ratio $\frac{\text{useful work got out}}{\text{total work put in}}$, or $\frac{\text{brake horse-power}}{\text{indicated horse-power}}$, is called the *efficiency* of the machine, or its mechanical efficiency, the usual value in steam-engines being about .85, or 85 per cent., in well designed and fitted engines.

Transmission dynamometers.—Fig. 450A shows one form of this type sufficiently general to illustrate it. A is a pulley on the engine shaft, and B is a pulley on the shaft to be driven. The motion is transmitted by means of a belt which passes over two equal pulleys, P and Q, which are attached to the ends of two equal arms of length, l , of a crosspiece, which is free to move about its centre R. An arm, S, is fixed at right angles to the crosspiece, to the end of which a definite force can be applied by means of a spring.

When A rotates, the tensions in the two sides of the belt alter; these different tensions remain practically the same throughout the two sides of the belt as it passes over the guide pulleys P and Q, any slight friction in these pulleys being neglected. This difference in tension, shown by the arrows in the figure, causes B to turn. T_1 being the greater, the turning force is $T_1 - T_2$.

From the figure it is seen that when steady motion is obtained the pulley P is pulled down by a force $2T_2$, and Q by a force $2T_1$.

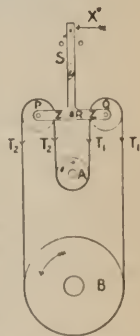

Fig. 450A

And this moment, $2T_1 \times l - 2T_2 \times l$, tending to turn the arm clockwise around R, is counterbalanced by a force X at the end of the arm S. So if y is the length of the arm S,

$$Xy = 2T_1l - 2T_2l.$$

Now $(T_1 - T_2) \times$ radius of B = resisting moment, and if the revolutions per minute (N) of B are measured, the work done per minute can be calculated, and has been measured during its transmission through the dynamometer, viz.

$$\begin{aligned} \text{Work done per minute} &= (T_1 - T_2) \times \text{radius of B} \times 2\pi N, \\ &= X \frac{y}{l} \times \text{radius of B} \times \pi N. \end{aligned}$$

480. **Efficiency of heat engines.**—There is another ratio of efficiency connected with the steam-engine, and common to all heat engines, namely the ratio

$$\frac{\text{Total work done by engine}}{\text{Total heat expended}},$$

which is called its *thermo-dynamic efficiency*. If T_1 and T_2 are respectively the *absolute temperatures* (337) of the steam and the resulting feed water drawn from the condenser in any engine, then it can be shown that such an engine, if working perfectly—that is to say, taking in all its heat at the highest limit of temperature and discharging it at the lowest limit—could transform *no more*

than $\left(\frac{T_1 - T_2}{T_1}\right)$ of the heat received into work. This fraction in the case of the steam-engine is seldom more than .25. The value of the actual efficiency of the engine is often from .10 to .14; while, therefore, an ordinary steam-engine, with such an efficiency, turns into work only from $\frac{1}{10}$ to $\frac{1}{6}$ of the whole heat it receives, yet it may be turning into work $\frac{1}{2}$ or more of the amount of heat which it could possibly transform into work if it were a perfect engine.

To increase the economy in steam-engines we require to make the value of $\left(\frac{T_1 - T_2}{T_1}\right)$ larger. This is done by raising T_1 or lowering T_2 , or both. A limit is placed on the lower temperature T_2 by the temperature of the atmosphere at the place of the engine. And in steam-engines T_1 has been limited by the corresponding pressure, which in late years has been increased to 315 pounds per square inch absolute.

481. **Hot-air engines.**—The difficulty as to T_1 just mentioned is got over by the use of some fluid whose pressure is not a function of its temperature, *air* being a convenient fluid for this purpose. Many 'hot-air' engines have been designed, and some have found considerable success commercially, as Rider's, Hock's, and Lehmann's. In all cases the engines consist essentially of one or two chambers placed so that one part or one chamber can be heated by a furnace, and the other cooled by a refrigerator or water jacket. The air is compelled to move from the cold space to the hot and back again continually. When hot it is allowed to expand and push

forward a piston; when cold it is compressed b the piston moving back again to its original position. The difference between these two quantities of work is the whole work done by the engine. By making T_1 a very high temperature, the theoretical efficiency $\left(\frac{T_1 - T_2}{T_1}\right)$ of an air engine may be made much higher than that of a steam-engine. But it is so much more difficult to obtain the theoretical efficiency in the air than in the steam-engine that its actual efficiency is generally much lower than that of the steam-engine. There are constructive difficulties connected with the hot-air chambers and with the regulation of the speed, and these, as well as the large bulk of most air engines in proportion to their power, have stood greatly in the way of their development. These engines might possibly have reached a higher state of perfection had not the introduction of gas and oil engines prevented it.

482. **Gas engines.**—Gas engines, like steam and air engines, are heat engines, but in them the working fluid is ordinary coal gas mixed with air,

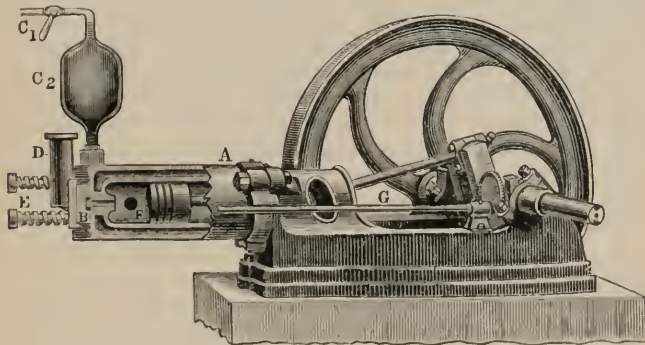

Fig. 450B

in the proportion of about 1 to 11 by volume. The principle of their action is very simple: the explosive mixture after being drawn into the cylinder is ignited, the heat generated by the very rapid combustion, which might be called a slow explosion, causes the mixed gases and products of combustion to expand and drive forward a piston. The great difficulty for many years was that the combustion was so rapid that the comparatively slow-moving piston could not keep up with it, and the greater part of the energy of the explosion was lost by radiation and conduction. In more modern engines, however (Otto's, Clerk's, and others), this difficulty is overcome by compressing the charge before ignition, a treatment which decreases the rapidity of combustion and so greatly increases the actual efficiency of the engine. Fig. 450B shows the principal parts of a successful type of gas engine. A is a cylinder, open at one end and therefore *single acting*, in which works a deep piston F, driving a crank in the usual manner. The cylinder is surrounded by a water jacket to prevent it getting too hot for good mechanical working; it may be noted that this loss of heat at once prevents the efficiency attaining the theoretical value possible. At the back of the

cylinder is a slide valve, B, worked by a cam motion from the crank shaft, the valve B being held against its face by spiral springs, E. D is a chamber in which a small jet of gas is kept continually burning for igniting the mixture. C₁ is the cock for admission of gas, and C₂ an india-rubber bag to maintain a constant gas pressure, and serve as a reservoir. The working of the engine is as follows: the piston moves from left to right and draws into the cylinder the explosive mixture; on the return stroke it compresses the mixture to about 3 atmospheres. The igniting flame is then allowed to come for an instant in contact with the compressed mixture, which burns very rapidly and pushes the piston forward again, the pressure rising to 10 or 12 atmospheres. On the next return stroke the products of combustion are forced out through an exhaust valve, which is opened by a cam motion worked from the engine shaft, and the process begins once more. It will thus be seen that there is one explosion in every four strokes of the engine, or every two revolutions, the heavy flywheel fitted acting as a store of energy during the explosion stroke, and a source of energy to carry on the motion during the remaining three strokes. There are many ingenious arrangements connected with this type of prime mover which our space will not allow us to mention in detail. It will suffice to say that the engine has been proved distinctly economical, and has very great conveniences beyond the fact that it does not require an installation of boilers, which this type of engine shares with similar ones using petroleum spirit or heavier petroleum oils as a motive power.

483. **Mineral oil as applied to heat engines. Oil motors.**—In recent years mineral oils have come into greater use as a source of power in what may be classed as three principal ways:—

I. Oil has been used as fuel in the furnaces of ordinary boilers to generate steam for driving steam-engines. In this case it is forced by jets of air or steam through nozzles into the furnace in a fine spray, and then burnt.

II. Oil has been used as fuel in a small boiler to evaporate oil of a low boiling point, and the generated vapour is used to drive small motors for land cars or small boats in the same way that steam is used in the steam-engine.

III. Oil has been admitted with a certain amount of air into the cylinder of a motor and then ignited, burning rapidly or exploding slowly (either term may be used); a large volume of gas is evolved, and produces a pressure which is used expansively in driving the piston. It is this form that is now so generally used in road motor cars, motor boats and stationary engines, and on that account a sketch and description of a common type is given.

The oil used, commonly called *petrol*, is one of the products obtained by distilling the natural petroleum common to America, Southern Russia, Burmah, and a few other places. Strictly speaking it should be called a 'spirit,' as it is of very low *flash-point*—i.e. the temperature at which the vapour given off ignites when a small test flame is applied. The residue after these oils of low flash-point have been distilled is a heavy oil of rather higher flash-point, and it is this oil that is used in Case I. for fuel in the furnace of a boiler.

The general arrangement of parts of a successful type of 'petrol' motor is given in fig. 450C, which shows in section one of the engines of which two

or more are coupled together for motor-car driving. The arrangement and action are similar to the gas engine previously described ; in this case it consists of three principal castings : the *cylinder head*, *cylinder barrel*, and *crank chamber*. The mechanism is that of the single, direct-acting, trunk engine, and the action is as follows :—

On the down-stroke of the piston F a partial vacuum is created in the dome at the top of the cylinder, and air is drawn in at the opening B, which, rushing through the annular space around the nozzle K, draws in a fine spray of oil. This *carburetted air* passes along the connecting pipe and through the spring loaded valve C, which is opened by the vacuum, and enters through the port D into the cylinder. On the piston rising this carburetted air is compressed in the dome combustion chamber to about 40 pounds per square inch ; at the instant the piston arrives at the top of its stroke the oil is ignited by the exposure of a red-hot tube or electric spark at H, and very rapid combustion takes place, producing a pressure which forces the piston down. On the next up-stroke the products of combustion are forced out of the cylinder through the exhaust valve E, which is opened, against a spring by the cam G connected by gearing with the crank shaft, acting on the lever R, and so lifting the valve-rod of the exhaust valve. These waste gases are completely driven out on the up-stroke through the exhaust pipe or *silencer* J, and the piston then descends, drawing in the next supply of carburetted air. The exhaust pipe connecting E with J is led around the cylinder, so as to supply the heat necessary for the rapid and ready ignition of the carburetted air. As in the gas engine, the working barrel of the cylinder is cooled by a water jacket, W, formed by the annular space around the cylinder barrel.

The three most important points in this kind of motor which make it an efficient working machine are :—

1. *The carburetter*, or mechanism by which the air and oil are intermixed. The oil is supplied from the storage tank through a pipe to the float chamber A, where the float M regulates the level of oil in the chamber by opening or closing the *needle-valve* N as the level falls or rises. This oil is then drawn through the nozzle, K, in a fine spray by the action of the in-rushing air at B. The entrance of air at B can be regulated by a valve worked from the

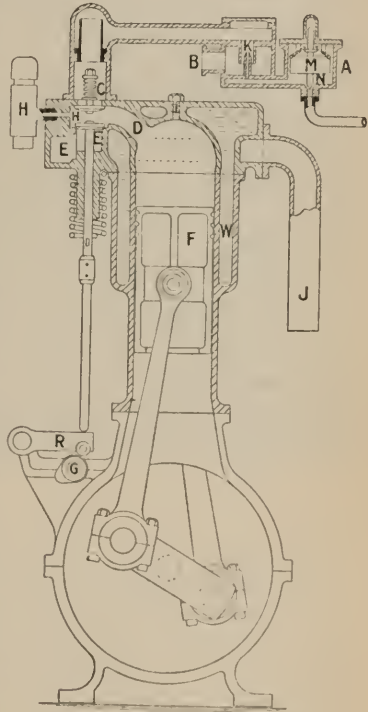

Fig. 450c

driving platform. Care should be taken to admit sufficient air for good combustion, otherwise soot and unburnt oil will be deposited on the working surfaces and valves, which is technically known as *sooting*.

II. *The igniter*. There are two general forms: first, a continuously burning oil flame in the chamber H heats a porcelain ignition tube at H, which tube is exposed by a cam motion worked from the engine shaft. This however is dangerous, for the flame may blow out, and in relighting an explosion is risked from the escape of oil; also if the car is overturned there is the risk of fire. For these reasons a second method is used which is at the same time capable of being better regulated, viz. an electric spark at H, the contact for which is made, at the right moment, by a cam motion as before. This second method, however, necessitates extra weight in the form of storage cells.

III. *The exhaust valve*. In order to regulate the power of the motor the lever R can, by means of a cam motion worked from the driving platform, be arranged so that the exhaust valve E is closed before the end of the stroke, the remainder of the waste products of the previous explosion being retained in the cylinder, so that on the next down-stroke only a small quantity of carburetted air is admitted, and the force of the next explosion is not so great.

In conclusion, it is as well to point out that, so long as they work between the same temperatures, there is no difference between steam, air, gas, and oil engines as to theoretical economy. The last three gain by the possibility of using higher limits of temperature than can be employed in a steam-engine, but, so far constructive and mechanical difficulties have prevented a large theoretical efficiency from being attained. This efficiency in oil and gas engines is however greater than that of the most efficient steam-engine.

CHAPTER XI

SOURCES OF HEAT AND COLD

484. **Different sources of heat.**—The following different sources of heat may be distinguished : i. the *mechanical sources*, comprising friction, percussion, and pressure ; ii. the *physical sources*—that is, solar radiation, terrestrial heat, molecular actions, change of conditions, and electricity ; iii. the *chemical sources*, or molecular combinations, and more especially combustion.

In what follows it will be seen that heat may be produced by reversing its effects ; as, for instance, when a liquid is solidified or a gas compressed (486) ; though it does not necessarily follow that in all cases the reversal of its effects causes heat to be produced—instead of it, an equivalent of some other form of energy may be generated.

In like manner heat may be forced to disappear, or cold be produced when a change such as heat can produce is brought about by other means, as when a liquid is vaporised or a solid liquefied by solution ; though here also the disappearance of heat is not always a necessary consequence of the production, by other means, of changes such as might be effected by heat.

MECHANICAL SOURCES

485. **Heat due to friction.**—The friction of two bodies, one against the other, produces heat, which increases with the pressure and with the rapidity of motion. For example, the axles of carriage wheels, by their friction against the boxes, often become so strongly heated as to take fire. By rubbing together two pieces of ice in a vacuum below zero, Sir H. Davy partially melted them. In boring a brass cannon Rumford found that the heat developed in the course of $2\frac{1}{2}$ hours was sufficient to raise $26\frac{1}{2}$ pounds of water from zero to 100° , which represents 2650 thermal units (452). Mayer raised water from 12° to 13° by shaking it. At the Paris Exhibition, in 1855, Beaumont and Mayer exhibited an apparatus, which consisted of a wooden cone covered with hemp, and moving with a velocity of 400 revolutions in a minute in a hollow copper cone, which was fixed and immersed in the water of an hermetically closed boiler. The surfaces were kept covered with oil. By means of this apparatus 88 gallons of water were raised from 10° to 130° in the course of a few hours.

In the case of flint and steel, the friction of the flint against the steel raises the temperature of the metallic particles, which fly off, heated to such an extent that they take fire in the air.

The luminosity of aerolites is considered to be due to their friction against the air, and to their condensation of the air in front of them (486), their velocity attaining as much as 150 miles in a second.

Tyndall devised an experiment by which the great heat developed by friction is illustrated in a striking manner. A small brass tube closed at one end (fig. 451) is fixed on a small wheel. The tube, three parts full of water,

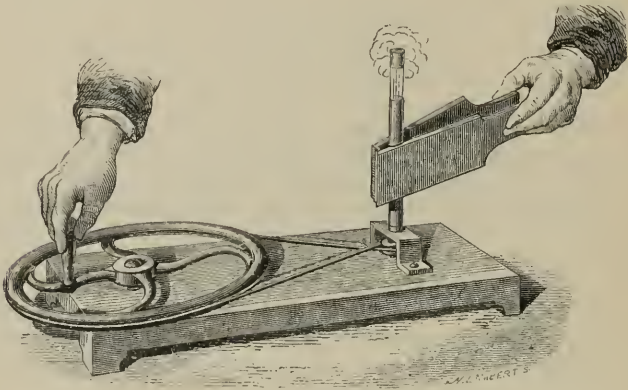

Fig. 451

is closed by a cork, and is pressed between a wooden clamp, while the wheel is rotated with some rapidity. The water rapidly becomes heated by the friction, and its temperature soon exceeding the boiling point, the cork is projected to a height of several yards by the elastic force of the steam.

486. **Heat due to pressure and percussion.**—If a body is so compressed that its density is increased, its temperature rises according as the volume diminishes. Joule verified this in the case of water and of oil, which were exposed to pressures of 15 to 25 atmospheres. In the case of water at $1\cdot2^{\circ}$ C., increase of pressure caused lowering of temperature—a result which agrees with the fact that water contracts by heat at this temperature. Similarly, when weights are laid on metal pillars, heat is evolved, and absorbed when they are removed. So in like manner the stretching of a metal wire is attended with a diminution of temperature.

The production of heat by the compression of gases is easily shown by means of the *pneumatic syringe* (fig. 452). This consists of a glass tube with thick sides, closed hermetically by a leather piston. At the bottom of this there is a cavity in which a small piece of cotton, moistened with ether or bisulphide of carbon, is placed. The tube being full of air, the piston is suddenly plunged downwards; the air thus compressed disengages so much heat as to ignite the cotton, which is seen to burn when the piston is rapidly withdrawn. The ignition of the cotton in this experiment indicates a temperature of at least 300° .

The rise of temperature produced by the compression in the above

experiment is sufficient to effect the combination, and therefore the detonation, of a mixture of hydrogen and oxygen.

A curious application of the principle of the pneumatic syringe is met with in the American *powder ram* for pile-driving. On the pile to be driven is fixed a powder mortar, above which is suspended at a suitable distance an iron rammer, shaped like a gigantic stopper, which just fits in the mortar. Gunpowder is placed in the mortar, and when the rammer is detached it falls into the mortar, compresses the air, producing so much heat that the powder is exploded. The force of the gases projects the rammer into its original position, where it is caught by a suitable arrangement; at the same time the reaction of the mortar on the pile drives this in with far greater force than the fall of the rammer. After adding a fresh charge of powder, the rammer is again allowed to fall, again produces heat, explosion, and so forth, so that the driving is effected in a surprisingly short time.

Percussion is also a source of heat. In firing shot at an iron target, a sheet of flame is frequently seen at the moment of impact; and Sir J. Whitworth used iron shells which are exploded by the concussion on striking an iron target. A small piece of iron hammered on the anvil becomes very hot.

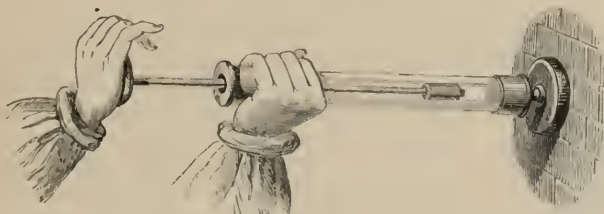

Fig. 452.

The heat due to the impact of bodies is not difficult to calculate. Whenever a body moving with a velocity v is suddenly arrested in its motion, its kinetic energy is converted into heat. This holds equally whatever be the cause to which the motion is due: whether it be that acquired by a stone falling from a height, by a bullet fired from a gun, or the rotation of a copper disc by means of a turning table. The energy of any moving body is expressed by $\frac{mv^2}{2}$, or in foot-pounds by $\frac{pv^2}{2g}$, where p is the weight in pounds, v the velocity in feet per second, and g is about 32 (32); and if the whole of this be converted into heat, its equivalent in thermal-units (pound-degrees Centigrade) will be $\frac{pv^2}{2g \times 1390}$. Suppose, for instance, a lead ball weighing a pound be fired from a gun, and strike against a target, what amount of heat will it produce? We may assume that its velocity will be about 1600 feet per second; then its kinetic energy will be $\frac{1 \times 1600^2}{2 \times 32} = 40,000$ foot-pounds. Some of this will have been consumed in producing the vibrations which represent the sound of the shock, some of it also in its change of shape; but neglecting these two as being small, and assuming

that the heat is equally divided between the ball and the target, then, since 40,000 foot-pounds is the equivalent of 28.7 thermal units, the share of the ball will be 14.3 thermal units; and if, for simplicity's sake, we assume that its initial temperature is zero, then, taking its specific heat at 0.0314, we shall have

$$1 \times 0.0314 \times t = 14.3, \text{ or } t = 457^{\circ} \text{C.},$$

which is a temperature considerably above that of the melting point of lead (341).

By allowing a lead ball to fall from various heights on an iron plate, both experience an increase of temperature which may be measured by the thermopile; and from these increases it may be easily shown that the heat is directly proportional to the height of fall, and therefore to the square of the velocity.

By similar methods Mayer calculated that if the motion of the earth were suddenly arrested the temperature produced would be sufficient to melt and even volatilise it; while, if it fell into the sun, as much heat would be produced as results from the combustion of 5000 spheres of carbon the size of our globe.

PHYSICAL SOURCES

487. **Solar radiation.**—The most intense of all sources of heat is the sun. Pouillet made the first accurate measurements of the heat energy of

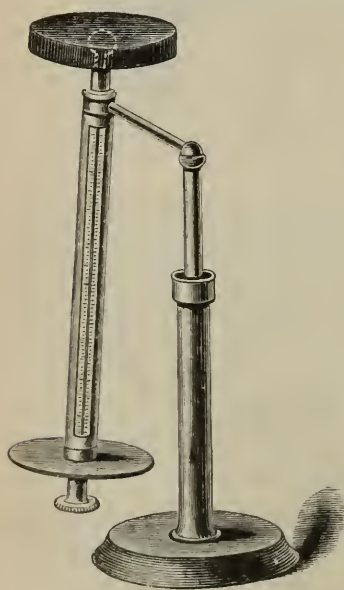

Fig. 453

the sun by means of an instrument called the *pyrohelium*. The form represented in fig. 453 consists of a flat cylindrical metal box 3 inches in diameter and $\frac{1}{2}$ an inch deep, containing a known weight of water. To it is fitted a metal tube which contains the stem of a delicate thermometer, the bulb of which dips in the liquid of the box, being fitted by means of a cork. The tube works in two collars, so that by means of a milled head it can be turned, and with it the vessel, and the liquid thus be uniformly mixed. The face of the vessel is coated with lampblack, and is so adjusted that the sun's rays fall perpendicularly upon it. This can be ascertained by observing when the shadow exactly covers the lower disc which is fitted to the same axis.

The instrument was exposed for five minutes at a time to the sun's rays; knowing the weight of the water, and the rise of temperature, we may easily calculate the heat absorbed by

it. Corrections were necessary for the heat reflected by the lampblack, and also for the heat absorbed by the air.

The *solar constant* Q is the quantity of heat in gramme-degrees which a square centimetre of a perfect absorbent would receive in a minute from the vertical sun's rays at the limit of the atmosphere. On the surface of the earth the value Q is less, but by determining it at various heights and combining the observations, the absorption by the atmosphere can be determined and Q ascertained.

The most trustworthy experiments give for this value 3 gramme calories. When the sun is in the zenith about one-third is absorbed and two-thirds reach the earth.

Of older data, Pouillet calculated from the results of experiments with his apparatus that if the total quantity of heat which the earth receives from the sun in the course of a year were employed to melt ice, it would be capable of melting a layer of ice all round the earth of 35 yards in thickness. Another statement is that the heat emitted by the sun is equal to that produced by the combustion of 1500 pounds of coal in an hour on each square foot of its surface. But from the surface which the earth exposes to the sun's radiation, and from the distance which separates the earth from the sun, the quantity of heat which the earth receives can only be $\frac{1}{2,881,000,000}$ of the heat emitted by the sun. Violle calculated the thickness of ice melted by the sun's heat at the equator, apart from absorption by the atmosphere, at 55 metres in thickness; and, deducting this absorption, at 37 metres.

The heat of the sun cannot be due to combustion, for even if the sun consisted of hydrogen, which of all substances gives the most heat in combining with oxygen, it can be calculated that the heat thus produced would not last more than 3000 years. Another supposition is that originally put forth by Mayer, according to which the heat which the sun loses by radiation is replaced by the fall of aerolites against its surface. One class of these is what we know as *shooting stars*, which often appear in the heavens with great brilliancy, especially on August 14 and November 15; the term *meteoric stone* or *aerolite* being properly restricted to the bodies which fall on the earth. They are often of considerable size, and are even met with in the form of dust. Although some of the sun's heat may be restored by the impact of such bodies against the sun, the amount must be very small, for Lord Kelvin has proved that a fall of 0.3 gramme of matter in a second on each square metre of surface would be necessary for this purpose. The effect of this would be that the mass of the sun would increase, and the velocity of the earth's rotation about the sun would be accelerated to an extent which would be detected by astronomical observations.

Helmholtz considers that the heat of the sun was produced originally by the condensation of a nebulous mass, and is kept up by a continuance of this contraction. A sudden contraction of the primitive nebular mass of the sun to its present volume would produce a temperature of 28 millions of degrees Centigrade; and a contraction of 0.0001 of its mass would be sufficient to supply the heat radiated by the sun in 2000 years. This amount of contraction could not be detected even by the most refined astronomical methods.

488. **Terrestrial heat.**—Our globe possesses heat peculiar to it, which is called *terrestrial heat*. The heat from the sun penetrates slowly by

conduction into the interior, and accordingly the maximum temperature will be at different depths at different times. Thus with four thermometers sunk at depths of 3, 6, 12, and 25.5 feet in the porphyry rock of the Calton Hill, Edinburgh, the registered maximum temperatures were on August 19, September 8, October 19, and January 4 respectively. But some of the heat is retained in each layer and raises the temperature so that the yearly variations diminish with the depth. For the above thermometers these were 8.2° , 5.6° , 2.7° , and 0.7° . From observations of this kind it is concluded that the solar heat does not penetrate below a certain internal layer, which is called the *layer of constant annual temperature*; its depth below the earth's external surface varies, of course, in different parts of the globe; at Paris, it is about 30 yards, and the temperature is constant at 11.8° C.

Below the layer of constant temperature, the temperature is observed to increase, on the average, 1° C. for every 90 feet. The most rapid increase is at Irkutsk in Siberia, where it is 1° for 20 feet, and the slowest in the mines at Mansfield, where it is about 1° C. for 330 feet. This increase has been verified in mines and artesian wells. According to this, at a depth of 3000 yards the temperature of a corresponding layer would be 100° , and at a depth of 20 to 30 miles there would be a temperature sufficient to melt all substances which exist on the surface. Hot springs and volcanoes confirm the existence of this central heat.

Various hypotheses have been proposed to account for the existence of this central heat. The one usually admitted by physicists is that the earth was originally in a liquid state in consequence of the high temperature, and that by radiation the surface has gradually solidified, so as to form a solid crust. The cooling must be very slow, owing to the small conductivity of the crust. For the same reason the central heat does not appear to raise the temperature of the surface more than $\frac{1}{36}$ of a degree.

Fourier calculated that the heat given off by the earth in 100 years would be sufficient to melt a layer of ice 3 metres in thickness, which therefore is only $\frac{1}{10000}$ of that received by the sun in the same time.

489. **Heat produced by absorption and imbibition.**—Molecular phenomena, such as imbibition, absorption, capillary actions, are usually accompanied by disengagement of heat. Pouillet found that whenever a liquid is poured on a finely divided solid, an increase of temperature is produced which varies with the nature of the substances. With in-

organic substances, such as metal, the oxides, the earths, the increase is $\frac{4}{10}$ of a degree; but with organic substances, such as sponge, flour, starch roots, dried membranes, the increase varies from 1 to 10 degrees.

The absorption of gases by solid bodies presents the same phenomena. Döbereiner found that when platinum, in the fine state of division known as *platinum black*, is placed in oxygen, it absorbs many hundred times its

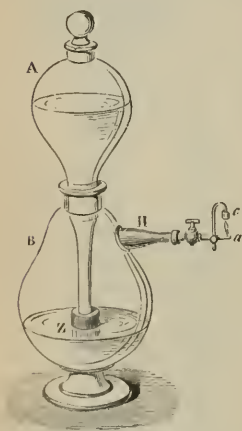

Fig. 454.

volume, and that the gas is then in such a state of density, and the temperature so high, as to give rise to strong combustion. Spongy platinum produces the same effect. A jet of hydrogen directed on it takes fire.

The apparatus known as *Döbereiner's lamp* depends on this property of finely divided platinum. It consists of two glass vessels (fig. 454). The first, A, fits in the lower vessel by means of a tubulure which closes it hermetically. At the end of the tubulure is a lump of zinc, Z, immersed in dilute sulphuric acid. By the chemical action of the zinc on the dilute acid hydrogen gas is generated, which, finding no issue, forces the liquid out of the vessel B into the vessel A, so that the zinc is not in contact with the liquid. The stopper of the upper vessel is raised to give exit to the air in proportion as the water rises. On a copper tube, H, fixed in the side of the vessel B, there is a small cone, *a*, perforated by an orifice; above this there is some spongy platinum in the capsule, *c*. As soon now as the cock, which closes the tube H, is opened, the hydrogen escapes, and, coming in contact with the spongy platinum, is ignited.

The condensation of vapours by solids often produces an appreciable rise of temperature. This is particularly the case with humus, which, to the benefit of plants, is warmer in moist air than the air itself.

Favre found that when a gas is absorbed by charcoal the amount of heat produced by the absorption of a given weight of sulphurous acid, or of nitrous oxide, greatly exceeds that which is disengaged in the liquefaction of the same weight of gas; for carbonic acid, the heat produced by absorption exceeds even the heat which would be disengaged by the solidification of the gas. The heat produced by the absorption of these gases cannot, therefore, be explained by assuming that the gas is liquefied, or even solidified in the pores of the charcoal. It is probably in part due to the liquefaction of the gas, and in part to the imbibition in the charcoal of the liquid so produced.

CHEMICAL SOURCES

490. **Chemical combination. Combustion.**—*Chemical combinations* are usually accompanied by a rise of temperature. When these combinations take place slowly, as when iron oxidises in the air, the heat produced is imperceptible; but if they take place rapidly, the disengagement of heat is very intense. The same quantity of heat is produced in both cases, but when evolved slowly it is dissipated as fast as formed.

Combustion is chemical combination attended with the evolution of light and heat. In ordinary combustion in lamps, fires, candles, the carbon and hydrogen of the coal, or of the oil, &c., combine with the oxygen of the air. But combustion does not necessarily involve the presence of oxygen. If either powdered antimony or a fragment of phosphorus is placed in a vessel of chlorine, it unites with the chlorine, producing thereby heat and flame.

Many combustibles burn with flame. A *flame* is a gas or vapour raised to a high temperature by combustion. Its illuminating power varies with the nature of the product formed. The presence of a solid body in the flame increases the illuminating power. The flames of hydrogen, carbonic oxide, and alcohol are pale, because they only contain gaseous products of

combustion. But the flames of candles, lamps, coal gas, have a high illuminating power. They owe this to the fact that the high temperature produced decomposes certain of the gases, with the production of carbon, which, not being perfectly burnt, becomes incandescent in the flame. Coal gas, when burnt in an arrangement by which it obtains an adequate supply of air, such as a Bunsen's burner, is almost entirely devoid of luminosity. A non-luminous flame may be made luminous by placing in it platinum wire or asbestos. The temperature of a flame does not depend on its illuminating power. A hydrogen flame, which is the palest of all flames, is the hottest.

Chemical decomposition, in which the attraction of heterogeneous molecules for each other is overcome, and they are moved further apart, is an operation requiring an expenditure of work or an equivalent consumption of heat; and conversely, in chemical combination, motion is transformed into heat. When bodies attract each other chemically their molecules move towards each other with gradually increasing velocity, and when impact has taken place the progressive motion of the molecules ceases, and is converted into a rotating, vibrating, or progressive motion of the molecules of the new body.

The heat produced by the chemical combination of two elements may be compared with that due to the impact of bodies against each other. Thus the action of the atoms of oxygen, which in virtue of their progressive motion, and of chemical attraction, rush against ignited carbon, has been likened by Tyndall to the action of meteorites which fall into the sun.

491. **Heat disengaged during chemical action.**—Many physicists, more especially Lavoisier, Rumford, Dulong, Despretz, Hess, Favre and Silbermann, Berthelot, Thomsen, and Andrews, have investigated the quantity of heat disengaged by various bodies in chemical actions.

Lavoisier used in his experiments the ice calorimeter already described. Rumford used a calorimeter known by his name, which consists of a rectangular copper canister filled with water. In this canister there is a worm which passes through the bottom of the

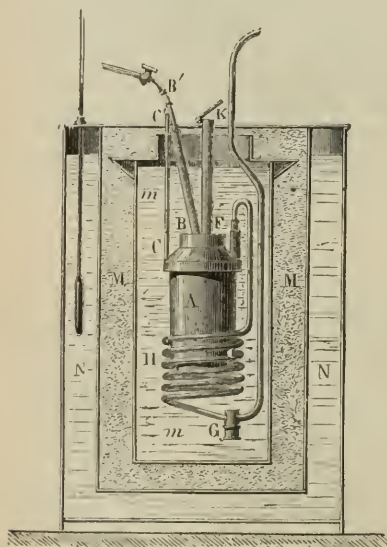

Fig. 455

box, and terminates below in an inverted funnel. Under this funnel is burnt the substance experimented upon. The products of combustion, in passing through the worm, heat the water of the canister, and from the increase of its temperature the quantity of heat evolved is calculated. Despretz and Dulong successively modified Rumford's calorimeter by allowing the com-

bustion to take place, not outside the canister, but in a chamber placed in the liquid itself; the oxygen necessary for the combustion entered by a tube in the lower part of the chamber, and the products of combustion escaped by another tube placed at the upper part and twisted in a serpentine form in the mass of the liquid to be heated. Favre and Silbermann improved this calorimeter very greatly (470), not only by avoiding or taking account of all possible sources of error, but by arranging it for the determination of the heat evolved in such chemical actions as take place between gases and vapours. The gases enter by tubes BB' and CC' (fig. 455) into a metal chamber A, where the reaction takes place, the course of which can be watched through a glass plate which closes a wider tube FK. The gaseous products before passing into the air traverse a long serpentine tube H, at the lower end of which is a small box G which receives the liquids arising from the condensation of the vapours. The cylinder A and the serpentine are surrounded by a known mass of water contained in a calorimeter, and from the rise in temperature of this water the heat developed can be calculated. To avoid any loss of heat this is placed within a metal case, MM, containing swan's down. The whole is contained in a vessel of water, NN, in which is a thermometer, to eliminate the influence of changes in the temperature of the air.

The experiments of Favre and Silbermann are the most trustworthy, as having been executed with the greatest care. They agree very closely with those of Dulong. The following table gives the heat, in calories, disengaged by a gramme of each of the substances while burning in oxygen:—

Hydrogen	34,462	Diamond	7770
Marsh gas	13,063	Absolute alcohol	7180
Ethylene	11,858	Coke	7000
Petroleum	11,000	Phosphorus	5750
Oil of turpentine	10,852	Coal gas	5600
Olive oil	9860	Wood, dried at 120°	3616
Ether	9030	Carbon bisulphide	3401
Anthracite	8460	Wood, ordinary	2756
Charcoal	8080	Carbonic oxide	2400
Coal	8000	Sulphur	2220
Tallow	8000	Zinc	1300
Graphite	7797	Iron	1181

The temperature attained by the burning of hydrogen in oxygen is limited by the fact that at a certain point dissociation of water vapour takes place. No such limit has been reached in the oxidation of aluminium; hence a very high temperature may be obtained by the rapid combustion of this method. A method depending on this fact, known as the *Thermit process*, has been developed in recent years for welding together masses of metal, e.g. iron rails. *Thermit* is a mixture of granulated aluminium and oxide of iron in atomic proportions. When at any point of the mixture the temperature is sufficiently raised the action between the components of the mixture begins; the iron oxide is decomposed, its oxygen being absorbed by the aluminium, which is converted into alumina, the whole mass rising

to a temperature of about 3000°C . The temperature at which the action begins is very high—about 1200° —and is obtained by placing on the thermit a small quantity of a fine powder consisting of aluminium mixed with barium peroxide. This mixture, which can be lighted by a match, produces the necessary temperature for starting the thermit reaction, and when started at any point it rapidly spreads through the whole mass.

Bunsen's calorimeter (456) has been used with advantage for studying the heat produced in chemical reactions, in cases in which only very small quantities are available.

For experiments on the heat of neutralisation of acids and bases the apparatus represented in fig. 456 may be used. *W* is a large vessel of water

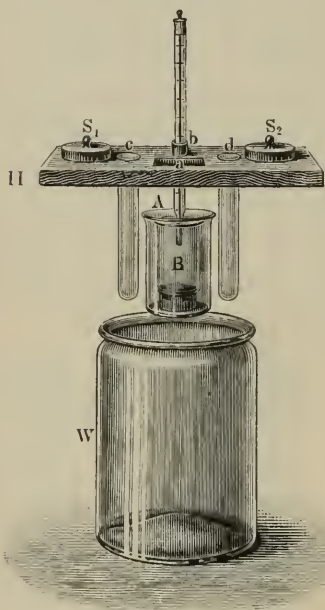

Fig. 456

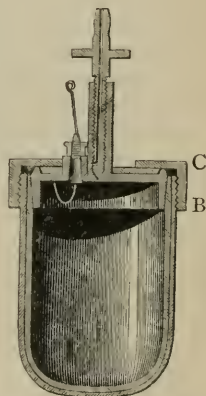

Fig. 457

of constant temperature; the beaker glass, *B*, which is the calorimeter, rests on a cork in the outer one, *A*. On the wooden lid, *H*, are two weights, S_1 and S_2 , to keep *A* down in the water; *c* and *d* are tubes placed in holes in the lid, and contain weighed quantities of the acid and base respectively; *b* is a delicate thermometer. After the tubes *c* and *d* have acquired the temperature of the water t , their contents are poured into *B* through an aperture in the lid for this purpose. When the reaction is complete, the temperature indicated by the thermometer, which reaches to the middle of *B*, rises to t_1 , so that, when we know the weight of the substances, and the rise of temperature $t_1 - t$, the quantity of heat produced in the reaction is easily determined.

492. **Berthelot's calorimetric bomb.**—This apparatus, represented in section in fig. 457, is small enough to be inserted in the water of a calori-

meter. It consists of a steel reservoir C lined with platinum, which can be hermetically closed by a screwed cover B. At the centre is a cylinder in which a tube can be turned, serving to admit the gases to be worked with. Near this is a carefully insulated platinum wire, which ends near the side of the apparatus; when an electric spark is passed it sets up the chemical reaction, the heat due to which is to be measured. For this purpose the bomb before the experiment is placed in a calorimeter, and from the rise in temperature of the known weight of water the quantity of heat can be deduced.

If a solid is to be burned it is placed in a platinum capsule, and the combustion set up by passing a current through a very fine platinum wire in contact with it.

493. **Endothermic and exothermic actions.**—All chemical actions, whether of combination or of decomposition, are attended by a disturbance of the thermal equilibrium; and the quantity of heat disengaged is a measure of the physical and chemical work.

In most cases the act of chemical combination is attended by a rise of temperature, and the quantity of heat is a measure of the energy developed in the reaction. Thus in the formation of one *molecule* of water there are liberated 68,924 thermal units, which may be written thus—



Those reactions which take place with disengagement of heat are said to be *exothermic*; there are, however, cases where bodies do not directly combine without the intervention of extraneous heat—for instance, iodine and hydrogen to form hydriodic acid; the equation for this is

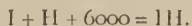

Such reactions are called *endothermic*.

Those bodies are most stable in the formation of which most heat is developed; thus the iron and zinc oxides, in the formation of which 1181 and 1300 units are respectively developed, are much more stable than silver oxide, in the formation of which only 27 units are developed. The heat of decomposition is the reciprocal of that of combination; those bodies which develop most heat in their formation require conversely an equivalent quantity to decompose them; decompositions which require an expenditure of heat to produce them are called *endothermic*. Those compounds, on the contrary, which absorb heat in their formation, develop an equivalent quantity in being decomposed, and the reactions are *exothermic*; they often take place with explosive violence, as in the case of the nitrogen chlorides and iodide. An exothermic reaction gives rise to an endothermic compound; and, conversely, an endothermic reaction forms an exothermic compound.

The oxidising compounds in most ordinary explosives, potassium chlorate and nitrate, are endothermic, evolving heat during decomposition which thus helps the reactions.

If there is any system of bodies which act on each other without the supply of extraneous energy, then that body or set of bodies results, in the formation of which most heat is produced. This is called the *principle of*

greatest chemical action. The chemical potential energy of the resulting bodies will be a minimum. The principle of greatest chemical action is a particular case of a more general principle which states that when two or more bodies are so related to each other that changes can take place among them, the change which occurs will always be such as to make the potential energy of the aggregate as small as possible.

The heat developed in any chemical reaction depends on the relation between the initial and the final products, and is independent of the nature and succession of the intermediate stages. It is equal to the sum of the quantities of heat produced in each stage, regard being had to the negative quantities due to such processes as solution and gasification.

Thus a gramme of carbon in burning to carbonic acid produces 8080 calories. If the same weight of carbon burns so as to form carbonic oxide, it forms 2473; and the combustion of the carbonic oxide resulting from this reaction yields 5607, making together 8080.

Potassium combines directly with chlorine to form potassium chloride, the heat of formation of which is 15,000 and is equal to that produced by the same weight of salt, whether this is formed by the direct union of hydrochloric acid and potash, or whether it is produced by the action of potassium on aqueous solution of hydrochloric acid.

The heat of combustion of a compound is not always equal to the sum of those of its constituents. The heat of combustion of carbon bisulphide is 3401, while that calculated from its constituents is 3145; the compound accordingly possesses more energy than its constituents, and its formation is due to an endothermic reaction.

Metameric bodies are those which contain the same number of elements but in different groupings; thus acetic acid and methylic formate have each the composition $C_2H_4O_2$; but the heat of combustion of the latter is 4157, and that of the former 3505; from this it is to be inferred that the grouping of the atoms to form acetic acid has been attended with the expenditure of more energy than in the case of methylic formate.

Polymeric bodies are those which have the same elements and the same percentage composition, but differ in the number of atoms which form a molecule. Thus the more complex the molecule the smaller is the quantity of heat. That of amylene, for instance, C_5H_{10} , is 11,401, and that of metamylenes, $C_{20}H_{40}$, is 10,908.

Many chemical elements, such as carbon, sulphur, and phosphorus, exist in modifications which are essentially different from each other in their physical properties, but which form, when they enter into combination with other elements, identical chemical products. Such bodies are said to have different allotropic forms which have different thermal values. The heat liberated when one allotropic form is changed into another—for instance, when charcoal is converted into diamond—cannot be directly determined, but must be arrived at by indirect methods.

A given weight of carbon, whether it is charcoal, graphite, or diamond, produces exactly the same weight of carbonic acid, though the heat of combustion is different. Thus, when a gramme each of charcoal, graphite, and diamond are severally burnt in oxygen in the calorimetric bomb, the heats produced are respectively 8137, 7900, and 7860 thermal units;

hence 237, the difference between the two former values, represents the heat developed in the transformation of one gramme of charcoal into graphite, and 40, the corresponding number, in the change from graphite to diamond.

The *temperature of combustion*, or, in the case of gases, the temperature of the flame, is the upper limit of the temperature which can be attained by the combustion of a body. This can be deduced from the heat of combustion, and from the specific heats of the bodies produced. The theoretical temperature of combustion of hydrogen in oxygen is calculated at 6715° ; this, however, is never even approximately reached, for at much lower temperatures aqueous vapour is *dissociated* (394) into its constituents, and the combustion cannot exceed a certain limit of temperature.

494. **Animal heat.**—In all the organs of the human body, as well as those of all animals, processes of oxidation are continually going on. Oxygen passes through the lungs into the blood, and so into all parts of the body. In like manner the oxidisable bodies, which are principally hydrocarbons, pass by the process of digestion into the blood, and likewise into all parts of the body, while the products of oxidation, carbonic acid and water, are eliminated by the skin, the lungs, &c. Oxidation in the muscle produces motions of the molecules which are changed into contraction of the muscular fibres; all other oxidations produce heat directly. When the body is at rest, all its functions, even involuntary motions, are transformed into heat. When the body is at work the more vigorous oxidations of the working parts are transferred to the others. Moreover, a great part of the muscular work is changed into heat, by friction of the muscles and of the sinews in their sheaths and of the bones in their sockets. Hence the heat produced by the body when at work is greater than when at rest. The blood distributes heat uniformly through the body, which in the normal condition has a temperature of 36.9° C. = 98.4° F. The blood of mammalia has the same temperature, that of birds is somewhat higher. In fever the temperature rises to 42° to 43° , and in cholera, or when near death, sinks as low as 35° .

The function of producing work in the animal organism was formerly considered as separate from that of the production of heat. The latter was held to be specially due to the oxidation of the hydrocarbons of the fat, while the work was ascribed to the chemical activity of the nitrogenous matter. This view has now been generally abandoned; for it has been found that during work there is no increase in the secretion of urea, which is the result of the oxidation of nitrogenous matter; moreover, the organism while at rest produces less carbonic acid, and requires less oxygen than when it is at work; and the muscle itself, both in the living organism and also when removed from it and artificially stimulated, requires more oxygen in a state of activity than when at rest. For these reasons the production of work is ascribed to the oxidation of the organic matter generally.

The process of vegetation in the living plant is not in general connected with any oxidation. On the contrary, under the influence of the sun's rays the green parts of plants decompose the carbonic acid of the atmosphere into free oxygen gas and into carbon, which, uniting with the elements of water, form cellulose, starch, sugar, and so forth. In order to effect this, an expenditure of heat is required which is stored up in the plant, and which

reappears during the combustion of the wood, or of the coal arising from its decomposition.

At the time of blossoming a process of oxidation goes on, which, as in the case of the blossoming of the *Victoria regia*, is attended with an appreciable rise of temperature.

HEATING

495. **Different kinds of heating.**—*Heating* is the art of utilising for domestic and industrial purposes the sources of heat which nature offers to us. Our principal source of artificial heat is the combustion of coal, coke, turf, wood, and charcoal.

496. **Fireplaces.**—Fireplaces are open hearths built against a wall under a chimney, through which the products of combustion escape.

However much they may be improved, fireplaces will always remain the most imperfect and costly mode of heating, for they render available only 13 per cent. of the total heat yielded by coal or coke, and 6 per cent. of that by wood. This enormous loss of heat arises from the fact that the current of air necessary for combustion always carries with it a large quantity of the heat produced, which is dissipated in the atmosphere. Hence Franklin said ‘fireplaces should be adopted in cases where the smallest quantity of heat was to be obtained from a given quantity of fuel.’ Notwithstanding their want of economy, however, they will always be preferred as the healthiest and pleasantest mode of heating, on account of the cheerful light which they emit, and the ventilation which they ensure.

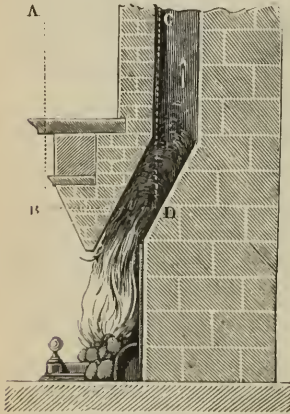

Fig. 458

497. **Draught of fireplaces.**—The *draught* of a fire is the upward current in the chimney caused by the ascent of the products of combustion; when the current is rapid and continuous, the chimney is said to *draw* well.

The draught is caused by the difference between the temperature of the inside and that on the outside of the chimney; for, in consequence of this difference, the gaseous bodies which fill the chimney are lighter than the air of the room, and consequently equilibrium is impossible. The weight of the column of gas CD (fig. 458) in the chimney being less than that of the external column of air AB of the same height, there is a pressure from the outside to the inside which causes the products of combustion to ascend the more rapidly in proportion as the difference in weight of the two gaseous masses is greater. The velocity of the draught of a chimney may be determined theoretically by the formula

$$v = \sqrt{2ga(t' - t)h},$$

in which g is the acceleration of gravity, a the coefficient of the expansion

of air, h the height of the chimney, t' the mean temperature of the air inside the chimney, and t the temperature of the surrounding air.

The currents caused by the difference in temperature of two communicating gaseous masses may be demonstrated by placing a candle near the top and near the bottom of the partially opened door of a warm room. At the top, the flame will be turned from the room towards the outside, while the contrary effect will be produced when the candle is placed on the ground. The two effects are caused by the current of heated air which issues by the top of the door, while the cold air which replaces it enters at the bottom.

In order to have a good draught, a chimney ought to satisfy the following conditions :—

i. The section of the chimney ought not to be larger than is necessary to allow an exit for the products of combustion ; otherwise ascending and descending currents are produced in the chimney, which cause it to smoke. It is advantageous to place on the top of the chimney a conical pot narrower than the chimney, so that the smoke may escape with sufficient velocity to resist the action of the wind.

ii. The chimney ought to be sufficiently high, for, as the draught is caused by the excess of the external over the internal pressure, this excess is greater in proportion as the column of heated air is longer.

iii. The external air ought to pass into the chamber with sufficient rapidity to supply the wants of the fire. In an hermetically closed room combustibles would not burn, or descending currents would be formed which would drive the smoke into the room. Usually air enters in sufficient quantity by the crevices of the doors and windows.

iv. Two chimneys should not communicate, for if one draws better than the other, a descending current of air is produced in the latter, which carries smoke with it.

For the strong fires required by steam boilers and the like, very high chimneys are needed ; of course the increase in height would lose its effect if the hot column above became cooled down. Hence chimneys are often made with hollow walls—that is, of separate concentric layers of masonry or brickwork—the space between them containing air.

498. **Stoves.**—*Stoves* are apparatus for heating with a detached fire, placed in a room to be heated, so that heat radiates in all directions round the stove. At the lower part is the draught-hole by which the air necessary for combustion enters. The products of combustion escape by means of iron chimney-pipes. This mode of heating is one of the most economical, but it is by no means so healthy as that by open fireplaces, for the ventilation is very bad, more especially where the stoves are fed from the outside of the room. These stoves also emit a bad smell, arising in part from the decomposition of organic substances which are always present in the air by their contact with the heated sides of the chimney-pipes ; or possibly, as Deville and Troost's researches seem to show, from the diffusion of gases through the heated sides of the stove.

The heating is very rapid with blackened metal stoves, but they also cool very rapidly. Stoves constructed of polished earthenware, which are common on the continent, heat more slowly, but more pleasantly, and they retain the heat longer.

499. **Heating by steam.**—Steam, in condensing, gives up its latent heat of vaporisation, and this property is used in heating baths, public buildings, hothouses, &c. For this purpose steam is generated in boilers like those used for steam-engines, and is then made to circulate in pipes placed in the room to be heated. The steam condenses, and in doing so imparts to the pipes its latent heat, which becomes free and thus heats the surrounding air.

500. **Heating by hot air.**—Heating by hot air consists in heating the air in the lower part of a building, whence it rises to the higher parts in virtue of its lessened density. The apparatus is arranged as represented in fig. 459.

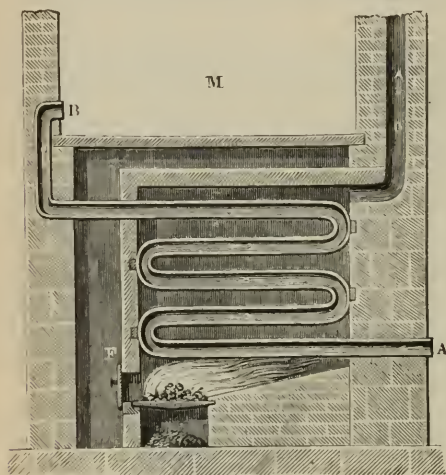

Fig. 459

ical than open fireplaces, but they are less healthy, unless special provision is made for ventilation.

501. **Heating by hot water.**—This consists of a continuous circulation of water, which, having been heated in a boiler, rises through a series of tubes, and then, after becoming cool, passes into the boiler again by a similar series. Fig. 460 represents an apparatus for heating a building of several stories. The heating apparatus, which is in the basement, consists of a bell-shaped boiler, *o o*, with an internal flue, *F*. A long pipe, *M*, fits in the upper part of the boiler, and also in the reservoir *Q*, placed in the upper part of the building to be heated. At the top of this reservoir there is a safety valve, *s*, by which the pressure of the vapour in the interior can be regulated.

The boiler, the pipe *M*, and a portion of the reservoir *Q*, being filled with water, as it becomes heated in the boiler an ascending current of hot water rises to the reservoir *Q*, while at the same time descending currents of colder and denser water pass from the lower part of the reservoir *Q* into receivers *b, d, f*, filled with water. The water from these passes again through pipes into other receivers, *a, c, e*, and ultimately reaches the lower part of the boiler.

During this circulation the hot water heats the pipes and the receivers, which thus become true water-stoves. The number and the dimensions of these parts are determined from the fact that a cubic foot of water in falling through a temperature of one degree can theoretically impart the same increase of temperature to 3200 cubic feet of air (466). In the interior of the receivers, *a, b, c, d, e, f*, there are cast-iron tubes which communicate with the outside by pipes, *P*, placed underneath the flooring. The air becomes heated in these tubes, and issues at the upper part of the receiver.

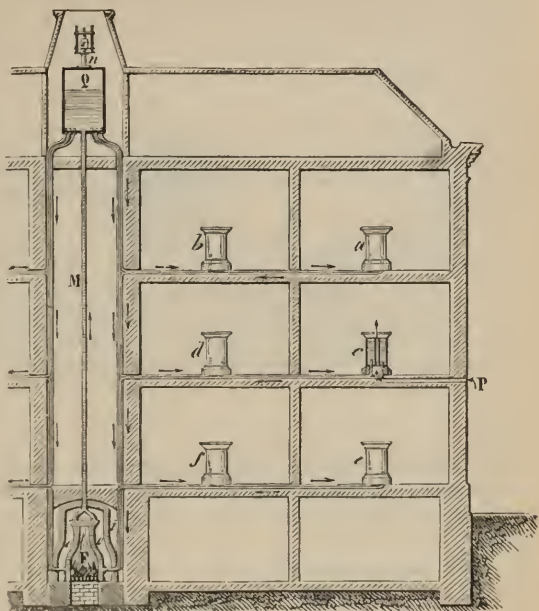

Fig. 460

The principal advantage of this mode of heating is that of giving a temperature which is constant for a long time, for the mass of water only cools slowly. It is much used in hot-houses, baths, artificial incubation, drying rooms, and generally wherever a uniform temperature is desired.

The principal advantage of this mode of heating is that of giving a temperature which is constant for a long time, for the mass of water only cools slowly. It is much used in hot-houses, baths, artificial incubation, drying rooms, and generally wherever a uniform temperature is desired.

SOURCES OF COLD

502. **Various sources of cold.**—Besides the cold caused by the passage of a body from a solid to the liquid state, or of a liquid to the gaseous state, of which we have already spoken, cold is produced by the expansion of gases, by radiation in general, and more especially by radiation at night.

503. **Cold produced by the expansion of gases. Ice machines.**—We have seen that when a gas is compressed the temperature rises (486). The reverse of this is also the case: when a gas is rarefied, a reduction of temperature ensues, because a quantity of sensible heat disappears when the gas becomes increased to a larger volume. This may be shown by placing a delicate Breguet's thermometer under the receiver of an air-pump, and exhausting; at each stroke of the piston the needle moves in the direction of zero, and regains its original position when air is admitted.

The production of cold when a gas is expanded has been extensively applied in machines for artificial refrigeration on a large scale. By

Windhausen's ice machine from 15,000 to 150,000 feet of air can be cooled in an hour, through 40 to 100 degrees in temperature, by means of a steam-engine of from 6 to 20 horse-power. The essential parts of this machine are represented in fig. 461. The piston B in the cylinder A is worked to the right by

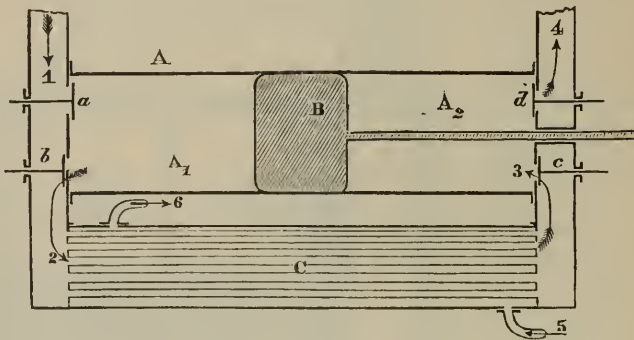

Fig. 461

a steam-engine, and to the left by a steam-engine and by the compressed air. As it moves towards the right the valve *a* opens, and air under the ordinary atmospheric pressure enters the space A_1 . When this is full the piston moves towards the left, the air in A_1 is compressed to about 2 atmospheres, the valve *a* is closed, the valve *b* opens, and air passes in the direction of the arrows into the cooler, C. By its compression it has become strongly heated, and the necessary cooling is effected by means of pipes through which cold water circulates, the water entering at 5 and emerging at 6. The air, thus compressed and cooled, passes out through the valve, *c*, which is automatically worked by the machine, into the space A_2 , where, in conjunction with the steam-engine, it moves the piston to the left, and compresses the air in A_1 ; for at a certain position of the piston the valve *c* is closed, the compressed air in the cylinder A_2 expands, and thereby is cooled far below the freezing point. As the piston moves again to the right, the valve *d* is opened by the working of the machine, and the cooled air emerges through the tube 4 to its destination. If it passes into an ordinary room, by condensing the moisture it fills it with snowflakes. Machines of this kind are extensively employed in the arts; in breweries, oil refineries, in the artificial production of ice, and in cooling rooms on board ship for the transport of dead meat, &c., which has become an industry of the greatest importance.

In the Linde machine the material used is ammonia gas, which is liquefied by compression and surface condensation. This liquid ammonia being allowed to evaporate takes the heat for this change of state from the surrounding bodies, which are thereby cooled. The ammonia vapour thus formed is again liquefied, and flowing back to the refrigerator is again evaporated, so that a small quantity of ammonia is always passing through the same cycle of operations.

A machine of this kind worked by a steam-engine of half a horse-power can cool in an hour 3400 cubic yards of air from 10° to 5° C., or 1400 cubic

yards from 6° to -4° C. ; or it will produce 1 cwt. of ice in the same time. The larger machines are relatively more advantageous.

504. **Cold produced by radiation at night.**—During the day the ground receives from the sun more heat than it radiates into space, and the temperature rises. The reverse is the case during night. The heat which the earth loses by radiation is no longer compensated, and consequently a fall of temperature takes place, which is greater according as the sky is clearer, for clouds send towards the earth rays of greater intensity than those which come from the celestial spaces. In some winters it has been found that rivers have not frozen, the sky having been cloudy, although the thermometer had been for several days below -4° ; while in other less severe winters the rivers freeze when the sky is clear. The emissive power exercises a great influence on the cold produced by radiation ; the greater it is, the greater is the cold.

In Bengal, the cooling by night is used in manufacturing ice. Large flat vessels containing water are placed on non-conducting substances, such as straw or dry leaves. In consequence of the radiation the water freezes, even when the temperature of the air is 10° C. The same method can be applied in all cases with a clear sky.

The Peruvians, in order to preserve the shoots of young plants from freezing, light great fires in their neighbourhood, the smoke of which, producing an artificial cloud, hinders the cooling produced by radiation.

CHAPTER XII

RELATION BETWEEN HEAT AND WORK

505. **Equivalence of heat and work.**—If the various instances of the production of heat by motion are examined, it will be found that in all cases mechanical energy is expended. Thus when two bodies are rubbed against each other motion is apparently destroyed by friction; it is not, however, lost, but appears in the form of a motion of the particles of the body; the motion of the mass is transformed into a motion of the molecules.

Again, if a body is allowed to fall from a height, it strikes against the ground with a certain velocity. According to older views, its motion is destroyed, its *vis viva* is lost. This, however, is not the case; the *vis viva* of the body or its *kinetic energy* appears as energy of its molecules.

In the case, too, of chemical action, the most productive artificial source of heat, it is not difficult to conceive that there is, in the act of combining, an impact of the dissimilar molecules against each other, an effect analogous to the production of heat by the impact of masses of matter against each other (486).

In like manner, heat may be made to produce motion, as in the case of the steam-engine, and the propulsion of shot from a gun.

Traces of a view that there is a connection between heat and motion are to be met with in the older writers, Bacon for example; and Locke says, 'Heat is a very brisk agitation of the insensible parts of the object, which produces in us that sensation from whence we denominate the object hot; so that what in our sensation is heat, in the object is nothing but motion.' Rumford, in explaining his great experiment of the production of heat by friction, was unable to assign any other cause for the heat produced than motion; and Davy, in the explanation of his experiment of melting ice by friction *in vacuo*, expressed similar views. Carnot, in a work on the steam-engine published in 1824, also indicated a connection between heat and work.

The views, however, which had been stated by isolated writers had little or no influence on the progress of scientific investigation, and it is in the year 1842 that the modern theories may be said to have had their origin. In that year Dr. Mayer, a physician in Heilbronn, formally stated that there exists a connection of simple proportionality between heat and work; and he it was who first introduced into science the expression '*mechanical equivalent of heat.*' Mayer also gave a method by which this equivalent could be calculated; the particular results, however, are of no value, as the method, though correct in principle, was founded on incorrect data.

In the same year, too, Colding of Copenhagen published experiments on

the production of heat by friction, from which he concluded that the evolution of heat was proportional to the mechanical energy expended.

About the same time as Mayer, but quite independently of him, Joule commenced a series of experimental investigations on the relation between heat and work. These first drew the attention of scientific men to the subject, and were admitted as a proof that the transformation of heat into mechanical energy, or of mechanical energy into heat, always takes place in a definite numerical ratio.

Subsequently to Mayer and Joule, several physicists, by their theoretical and experimental investigations, have contributed to establish the mechanical theory of heat: namely, in this country, Lord Kelvin and Rankine; in Germany, Von Helmholtz, Clausius, and Holtzmann; and in France, Clapeyron and Regnault.

506. **Determination of the mechanical equivalent of heat.**—The following are some of the most important and satisfactory of Joule's experiments.

A copper vessel, B (fig. 462), was provided with a brass paddle-wheel (indicated by the dotted lines), which could be made to rotate about a

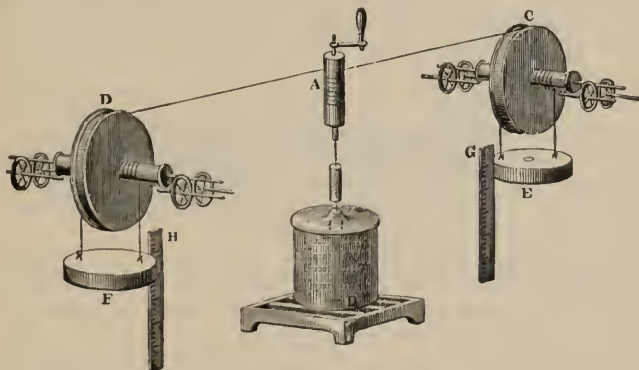

Fig. 462

vertical axis. Two weights, E and F, were attached to cords which passed over the pulleys C and D, and were connected with the axis A. These weights in falling caused the wheel to rotate. The height of the fall, which in Joule's experiments was about 63 feet, was indicated on the scales G and H.

The roller A was so constructed that by detaching a pin the weights could be raised without moving the wheel. The vessel B was filled with water and placed on a stand, and the weights allowed to sink. When they had reached the ground, the roller was detached from the axis, and the weights again raised, the same operations being repeated twenty times. The heat produced was measured by ordinary calorimetric methods (457).

The work expended is measured by the product of the weight into the height through which it falls, or ph , less the work lost by the friction of the various parts of the apparatus. This is diminished as far as possible by the use of friction wheels (79), and its amount is determined by connecting C

and D without causing them to pass over A, and then determining the weight necessary to communicate to them a uniform motion.

In this way it has been found that a thermal unit—that is, the quantity of heat by which a pound of water is raised through 1° C.—is generated by the expenditure of the same amount of work as would be required to raise 1392 pounds through 1 foot, or 1 pound through 1392 feet. This is expressed by saying that the mechanical equivalent of the thermal unit is 1392 foot-pounds.

The friction of an iron paddle-wheel in mercury gave 1397 foot-pounds, and the friction of two iron plates gave 1395 foot-pounds, as the mechanical equivalent of one thermal unit.

In another series of experiments, the air in a receiver was compressed by means of a force-pump, both being immersed in a known weight of water at a known temperature. After 300 strokes of the piston the heat, C, was measured which the water had gained. This heat was due to the compression of the air and to the friction of the piston. To eliminate the latter influence, the experiment was repeated under the same conditions, but with the receiver left open. The air was not compressed, and 300 strokes of the piston developed C' thermal units. Hence $C - C'$ is the heat produced by the compression of the air. Representing the foot-pounds expended in producing this heat by W, we have $\frac{W}{C - C'}$ for the value of the mechanical equivalent.

By this method Joule obtained the number 1442.

The mean number which Joule adopted for the mechanical equivalent of one thermal unit on the Centigrade scale is 1390 foot-pounds; on the Fahrenheit scale it is 772 foot-pounds. The number is called *Joule's equivalent*, and is usually designated by the symbol J.

On the metric system 424 metres are usually taken as the height through which a kilogramme of water must fall to raise its temperature 1 degree Centigrade. This is equal to 41,600,000 ergs, or 4.16×10^7 grammes raised through a height of a centimetre, taking $g = 981$.

Professor Rowland of Baltimore has recently made a very careful and complete determination of the mechanical equivalent of heat, by Joule's method, in which he has examined and allowed for all possible sources of error. His results give 4.269×10^7 grammes centimetre or 1401 foot-pounds as the mean value of this constant for the latitude of Baltimore; and this value is in close agreement with a still more recent determination by Mr. E. H. Griffiths, who found, by an electric method, 4.199×10^7 ergs, or 1403.6 foot-pounds for the latitude of Greenwich ($g = 981.17$), and by Micalescu, who found 4.187×10^7 for the latitude of Paris ($g = 980.96$).

The mechanical equivalent depends of course on the specific heat of water, and therefore varies with the temperature (463). According to Callendar and Barnes (1899) it is expressed in joules per C. degree by the formula

$$J = 4.174 + .0000188 (t - 40)^2$$

showing a minimum value to occur at 40° C.

Hirn made the following determination of the mechanical equivalent by means of the heat produced by the compression of lead. A large block of

sandstone, CD (fig. 463), is suspended vertically by cords; its weight is P . E is a piece of lead, fashioned so that its temperature may be determined by the introduction of a thermometer. The weight of this is Π , and its specific heat c . AB is a cylinder of cast iron, whose weight is ϕ . If this is raised to $A'B'$, a height of h , and allowed to fall again, it compresses the lead, E, against the anvil, CD. It remains to measure on the one hand the work spent, and on the other the heat gained.

The hammer AB being raised to a height h , the work of its fall is ϕh ; but as, by its elasticity, it rises again to a height h_1 , the work is $\phi(h-h_1)$. The anvil CD, on the other hand, has been raised through a height H to $C'D'$, and has required in so doing PH units of work. The work, W , definitely absorbed by the lead is $\phi(h-h_1) - PH$. On the other hand, the lead has been heated by θ , it has gained $\Pi c\theta$ thermal units, c being the

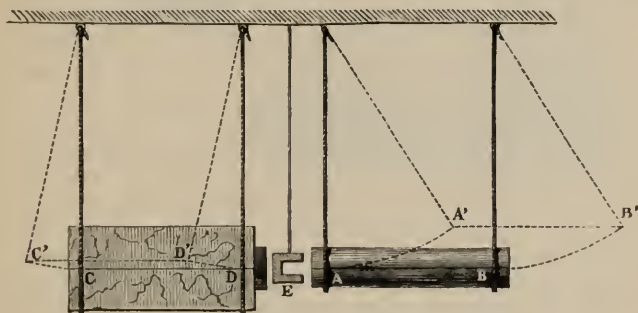

Fig. 463

specific heat of lead, and the mechanical equivalent J is equal to the quotient $\frac{W}{\Pi c\theta}$. A series of six experiments gave 1394 foot-pounds Centigrade for the mechanical equivalent as thus obtained.

The experiments of Cantoni and Gerosa in this direction are the simplest. They allowed mercury to fall from a funnel through a narrow tube into a vessel below, when its temperature was measured. In this way the number 1390 was obtained.

Experiments in the opposite direction have also been made, in which the work produced by one thermal unit was determined. This was done on a large scale by Hirn by means of a steam-engine of one hundred horse-power. He determined the quantity of heat contained in the steam before its action, and then the amount contained in the water after its condensation. This was less, for some had been expended in work; and this work as measured by the dynamometer was equivalent to that which had disappeared, the number 1390.7 being thus obtained.

The following is the method which originally Mayer employed in calculating the mechanical equivalent of heat. It is taken, with slight modifications, from Tyndall's work on *Heat*, who, while strictly following Mayer's reasoning, has corrected his data.

Let us suppose that a rectangular vessel with a section of a square foot

contains at 0° a cubic foot of air under the ordinary atmospheric pressure ; and let us suppose that it is inclosed by a piston without weight.

Suppose now that the cubic foot of air is heated until its volume is doubled ; from the coefficient of expansion of air we know that this is the case at 273° C. The gas in doubling its volume will have raised the piston through a foot in height ; it will have lifted the atmospheric pressure through this distance. But the atmospheric pressure on a square foot is in round numbers $15 \times 144 = 2160$ pounds. Hence a cubic foot of air in doubling its volume has lifted a weight of 2160 pounds through a height of a foot.

The quantity of heat which will double the volume of a cubic foot of air, and in so doing will lift 2160 pounds through a height of a foot, is 5.29 thermal units, taking the specific heat of air to be 0.24 at constant pressure.

Now in the above case the gas has been heated under constant pressure, that is, when it could expand freely. If, however, it had been heated under constant volume, its specific heat would have been less in the ratio 1 : 1.414 (466), so that the quantity of heat required under these circumstances to raise the temperature of a cubic foot of air would be $5.29 \times \frac{1}{1.41} = 3.74$.

Deducting this from 5.29, the difference 1.55 represents the weight of water which would have been raised 1° C. by the excess of heat imparted to the air when it could expand freely. But this excess has been consumed in the work of raising 2160 pounds through a foot. Dividing this by 1.55 we have 1393. Hence the heat which will raise a pound of water through 1° C. will raise a weight of 1393 pounds through a height of a foot ; a numerical value of the mechanical equivalent of heat agreeing as closely as can be expected with that which Joule adopted as the most certain of his experimental results.

The value of J, the mechanical equivalent of heat, as determined by Joule and also by more recent observers (Griffiths, Rowland, Barnes, &c.), is given in the subjoined table in various units.

	Joule	Recent observers
Foot-pounds Fahrenheit	772	779
„ „ Centigrade	1390	1403
Kilogramme-metres Centigrade	424	428
Ergs	4.16×10^7	4.2×10^7

A convenient practical unit of work or energy is 10^7 ergs ; it is called a *joule*. One calorie = 42×10^6 ergs = 4.2 joules.

A variety of experiments may in like manner be adduced to show that whenever heat disappears work is produced. For example, suppose that the air in a reservoir immersed in water is compressed to the extent of 10 atmospheres, and that, when the compressed air has acquired the temperature of the water, it be allowed to act upon a piston loaded by a weight, the result is that the weight is raised. At the same time the water becomes cooler, showing that a certain quantity of heat had disappeared in producing the mechanical effort of raising the weight. This may also be illustrated by the following experiment (fig. 464), due to Tyndall:—

A strong metal box is taken, provided with a stopcock, on which can be

screwed a small condensing pump. Having compressed the air since it becomes heated by this process, the box is allowed to stand for some time, until it has acquired the temperature of the surrounding medium. On opening the stopcock the air rushes out ; it is expelled by the expansive

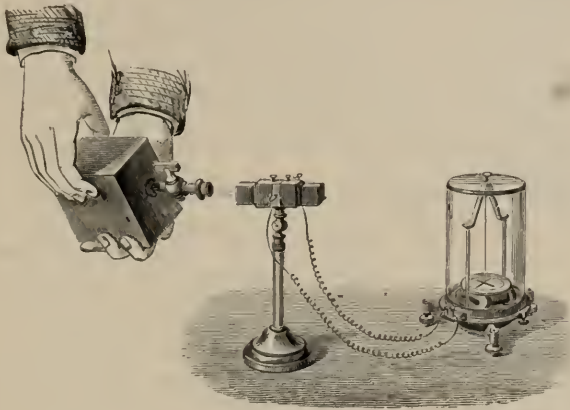

Fig. 464

force of the internal air ; in short, the air drives itself out. Work is therefore done by the air against external pressure, and there should be a disappearance of heat ; and if the jet be allowed to strike against the thermopile, the galvanometer is deflected, and the direction of its deflection indicates a



Fig. 465

cooling (fig. 464). A similar effect is observed when, on opening a bottle of soda-water, the carbonic acid gas which escapes is allowed to strike against the thermopile.

If, on the contrary, the experiment is made with an ordinary pair of

bellows, and the current of air is allowed to strike against the pile, the deflection of the galvanometer is in the opposite direction, indicating an increase of temperature (fig. 465). In this case the hand of the experimenter performs the work, which is converted into heat.

Joule placed in a calorimeter two equal copper reservoirs, which could be connected by a tube. One of these contained air at 22 atmospheres, the other was exhausted. When they were connected, they came into equilibrium under a pressure of 11 atmospheres; but as the gas in expanding had done no work, there was no alteration in temperature. When, however, the second reservoir was full of water, the air in entering was obliged to expel it and thus perform work, and the temperature sank, owing to an absorption of heat.

507. **Isothermal and adiabatic lines.**—Reference has already been made to isothermal lines in connection with the experiments of Dr. Andrews on carbonic acid. We will now examine the subject more generally. An isothermal line of a substance is a line drawn in reference to two co-ordinate axes in such a way that, however the properties of the substance—denoted by lengths measured along the co-ordinate axes—vary, its temperature remains always the same. If pressures are measured along the vertical, and volumes along the horizontal line, the isothermal lines of a gas for which Boyle's law is true ($p\nu = \text{const.}$) are rectangular hyperbolas.

In fig. 466 the curve LL' represents the behaviour of a certain quantity of the gas at constant temperature t_1 . Whatever be its volume and pressure, the state of the gas will be denoted by some point on this curve, the form of the curve being

fixed by the fact that $Op_1 \times Ov_1 = Op_2 \times Ov_2$, wherever A and B may be. If the temperature is raised and kept constant at t , we get another isothermal, MM', which will be farther away from the axes, since for a given volume the pressure will be greater than at the lower temperature. Thus, for a perfect ideal gas the isothermal lines are a series of rectangular hyperbolas farther and farther away from the axes as the temperature is higher. For a real gas, far removed from its temperature of liquefaction, the isothermal lines do not differ materially from those

shown, but the deviation from the hyperbolic form becomes marked as the temperature of liquefaction is approached. The isothermal lines for carbonic acid are shown in fig. 356; GA represents the substance in the gaseous condition at 13°C. , AB the substance partly liquefied, and BL entirely liquid. Similarly we may draw lines to represent the variations of pressure and volume of any other substance, whether solid, liquid, or gaseous, at any constant temperature.

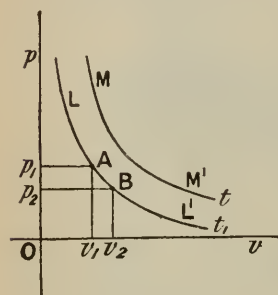

Fig. 466

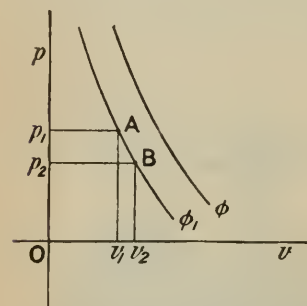

Fig. 467

If the changes of volume and pressure of a substance (say a gas) occur in such a way that no heat is gained or lost, they are said to take place *adiabatically*, and the curves exhibiting the variations of pressure and volume under these conditions are called *adiabatic lines*.

In fig. 467 let $\phi_1, \phi \dots$ be adiabatics of a gas, and let B denote the state of the gas at temperature, pressure, and volume, t_2, p_2, v_2 respectively. If the volume is reduced to v_1 and no heat escapes, the temperature will rise and the pressure become $p_1 (=Op_1)$, greater than it would have been with isothermal contraction. Thus the adiabatic through B is steeper than the isothermal, and so for other points. The equation to an adiabatic line, that is, the relation between p and v which characterises it, is $pv^\gamma = \text{const.}$, where $\gamma = C_p/C_v$, the ratio of the specific heat of a gas at constant pressure to its specific heat at constant volume (466).

508. **Carnot's cycle.**—Referring to fig. 466, let the state of the substance be denoted by A, that is, let p_1, v_1, t_1 be its pressure, volume, and temperature respectively. Suppose the substance to receive heat and to expand without change of temperature from v_1 to v_2 , then work is done *by* the expanding substance, the amount of which may be proved to be equal to the area Av_1v_2BA . If work is done *upon* the substance so that it contracts from v_2 to v_1 , the work so done is represented by the same area. Similarly, if the substance expands or contracts adiabatically (fig. 467), the work done is equal to the area enclosed between the curve, the horizontal axis, and the ordinates of the points representing the initial and final states.

Imagine a heat engine, whose working substance may be any fluid, to perform a series or cycle of operations, that is, to receive or give out heat and to do work or have work done upon it in such a way that at the end of the series the substance is in exactly the same state as to pressure, volume, and temperature as at the beginning. Then we are sure that on the whole no internal work has been done, and we may draw conclusions as to the heat given or received, and the work done by the substance or spent upon it. There are many ways in which such a series might be arranged; that chosen by Carnot, and known as *Carnot's cycle*, involves four distinct operations.

Let the state of the substance be denoted by the point A (fig. 468), its temperature, volume, and pressure being t_1, v_1, p_1 .

1. Let work be done on the substance, and its volume diminished from v_1 to v_2 . If the heat produced by the compression is not allowed to escape, the substance will be heated; let its temperature rise from t_1 to t . Its state is now represented by the point B, AB being an adiabatic. The work done is the area BAv_1v_2B .

2. The substance expands at constant temperature t , receiving a quantity of heat, H calories (= JH ergs), and its volume increases from v_2 to v_3 . The line BC is an isothermal, and the work done *by* the substance is Bv_2v_3CB .

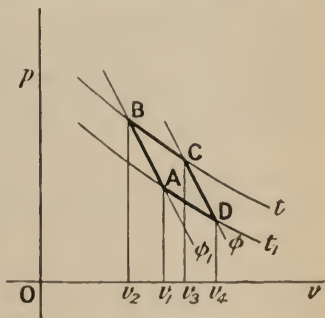

Fig. 468

3. The supply of heat is now cut off, and the substance continues to expand, neither receiving nor giving out heat, until its temperature falls to t_1 . Its state is denoted by D, the line CD being an adiabetic. The work done by the substance is Cv_3v_4DC .

4. The substance is compressed isothermally at t_1 , a quantity of heat H_1 being taken from it to keep its temperature constant. Eventually the temperature and volume become what they were at first. Thus the cycle is completed, the state of the working substance being in all respects the same at the end as it was at the beginning.

The total work done by the expanding substance is Bv_2v_4DCB ; that done upon it during contraction, Bv_2v_4DAB ; the difference between these is the area ABCD, which therefore represents the work done by the engine during the cycle = W . The heat H was taken in at the higher temperature t , and H_1 given up at the lower temperature t_1 ; $H - H_1$ calories, or $J(H - H_1)$ ergs, is therefore the quantity utilised. Hence $W = J(H - H_1)$ by the first law.

Suppose that in the above set of operations we had proceeded in the reverse direction, that is, allowed the substance to expand from A to D, supplying it with heat H_1 to keep its temperature constant, then compressed it adiabatically from D to C and isothermally from C to B, taking from it during the isothermal compression a quantity H of heat, and finally bringing it back to the state A. In this case work equal to ABCD (= W) has been done upon the substance, heat H_1 has been given to it, and H withdrawn from it; therefore $W + JH_1 = JH$. The engine works equally satisfactorily in this case, but every operation is reversed. For this reason Carnot's cycle is called a *reversible* cycle.

A reversible engine is in a certain sense a perfect engine, for its efficiency is greater than that of any other engine working between the same temperatures. This Carnot proved by supposing two engines, one reversible, the other non-reversible, working between the temperatures t and t_1 , to be coupled together, the latter driving the former. He showed that (on the assumption that the non-reversible engine has the greater efficiency) the result must be that by the simple action of the two engines heat is transferred from the cold body at t_1 , to the hot body at t , without any work being done by any external agency. This is contrary to experience. The efficiency of an engine may be defined as that fraction of the total amount of heat received which is converted into work. If H = heat received and H_1 = that given up, heat utilised as work = $H - H_1$; hence efficiency = $\frac{H - H_1}{H}$.

The efficiency of Carnot's engine clearly depends upon the difference of temperature $t - t_1$; for t being kept constant, and H , as before, being received from the source, if we take an isothermal corresponding to a lower temperature t_1 the area ABCD becomes larger. Hence E , the efficiency, = $C(t - t_1)$, where C is a constant known as Carnot's function; it is equal to $1/t$, if t and t_1 are measured from the absolute zero of temperature. Hence

$$E = \frac{H - H_1}{H} = \frac{t - t_1}{t} \quad (481), \text{ or } \frac{H}{H_1} = \frac{t}{t_1}.$$

The efficiency of Carnot's engine depends only on the temperatures at

which heat is taken in and rejected, and not on the properties of the working substance. This constitutes what is known as *Carnot's principle*.

The second law of thermodynamics has not so far been defined, though it has been assumed. The enunciation of it has taken many forms. Clausius put it thus :—No engine can of itself, without the aid of external agency, transfer heat from a body at a low temperature to a body at a high temperature. Another form of the second law is the statement of the impossibility of any engine being more efficient than a reversible engine.

509. **Dissipation of energy.**—Rankine made the following interesting observations on a remarkable consequence of the mutual convertibility which has been shown to exist between heat and other forms of energy :—Lord Kelvin has pointed out the fact that there exists, at least in the present state of the known world, a predominating tendency to the conversion of all other forms of physical energy into heat, and to the uniform diffusion of heat throughout all matter. The form in which we generally find energy originally collected is that of a store of chemical power consisting of uncombined elements. The combination of these elements produces energy in the form known by the name of electric currents, part only of which can be employed in electrolysing chemical compounds, and thus reconverted into a store of chemical power ; the remainder is necessarily converted into heat ; and again, only a part of this heat can be employed in electrolysing compounds or in reproducing electric currents. If the remainder of the heat is employed in expanding an elastic substance, it may be converted entirely into visible motion, or into a store of visible mechanical power (by raising weights, for example), provided the elastic substance is enabled to expand until its temperature falls to the point which corresponds to the absolute privation of heat ; but unless this condition is fulfilled a certain proportion only of the heat, depending on the range of temperature through which the elastic body works, can be converted, the rest remaining in the state of heat. On the other hand, all visible motion is of necessity ultimately converted into heat by the agency of friction. There is, then, in the present state of the known world, a tendency towards the conversion of all physical energy into the sole form of heat.

Heat, moreover, tends to diffuse itself uniformly by conduction and radiation, until all matter shall have acquired the same temperature. There is consequently, so far as we understand the present condition of the universe, a tendency towards a state in which all physical energy will be in the state of heat, and that heat so diffused that all matter will be at the same temperature ; so that there will be an end of all physical phenomena.

Vast as this speculation may seem, it appears to be soundly based on experimental data, and to truly represent the present condition of the universe as far as we know it.

BOOK VII

ON LIGHT

CHAPTER I

TRANSMISSION, VELOCITY, AND INTENSITY OF LIGHT

510. **Theories of light.**—*Light* is the agent which, by its action on the retina, excites in us the sensation of vision. That part of physics which deals with the properties of light is known as *optics*.

In order to explain the origin and transmission of light, various hypotheses have been made, the most important of which are the *emission* or *corpuscular* theory, and the *undulatory* theory.

On the *emission* theory it is assumed that luminous bodies emit, in all directions, an imponderable substance, which consists of molecules of an extreme degree of tenuity : these are propagated in right lines with an almost infinite velocity. Penetrating into the eye they act on the retina, and determine the sensation which constitutes vision.

On the undulatory theory, all bodies, as well as the celestial spaces, are filled by an extremely subtle elastic medium, which is called the *luminiferous ether*. The luminosity of a body is due to an infinitely rapid vibratory motion of its molecules, which, when communicated to the ether, is propagated in all directions in the form of spherical waves, and this vibratory motion, being thus transmitted to the retina, calls forth the sensation of vision. The vibrations of the ether take place not in the direction in which the wave is travelling, but in a plane at right angles to it. An idea of these may be formed by shaking a rope at one end. The vibrations, or to and fro movements, of the particles of the rope, are at right angles to the length of the rope, but the onward motion of the wave's form is in the direction of the length. See the remarks in articles 59, 226, 433.

On the emission theory the propagation of light is effected by a motion or *translation* of particles of light thrown out from the luminous body, as a bullet is discharged from a gun ; on the undulatory theory there is no progressive motion of the particles themselves, but only of the state of disturbance which was communicated by the luminous body ; and this is transmitted by the vibratory motion of the particles of the luminiferous ether.

The luminiferous ether penetrates all bodies, but on account of its extreme tenuity it is uninfluenced by gravitation ; it occupies space, and although it presents no appreciable resistance to the motion of the denser

bodies, it is possible that it hinders the motion of the smaller comets. It has been found, for example, that Encke's comet, whose period of revolution is about $3\frac{1}{2}$ years, has its period diminished by about 0.11 of a day at each successive rotation, and this diminution is ascribed by some to the resistance of the ether.

Graetz has calculated that the density of ether is 9×10^{-16} that of water. From a formula of Lord Kelvin it is calculated to be greater than 10^{-18} ; it may accordingly be admitted to be 10^{-17} . While the mass of air over a square metre is 10,000 kilogrammes, that of the ether in it, taking the height of the atmosphere at 45 kilometres, would be only 0.0004 milligramme. Kelvin concludes that the density of the air, if it followed Boyle's law, and the temperature was constant, would at a height equal to that of the earth's radius be only 10^{-850} that of water. The ether is therefore far more dense than air so rarefied. He calculated that a volume equal to that of the earth cannot contain less than 1260 kilogrammes of ether.

The fundamental principles of the undulatory theory were enunciated by Huyghens, and subsequently by Euler. The emission theory, principally owing to Newton's powerful support, was for long the prevalent scientific creed. The undulatory theory was adopted and advocated by Young, who showed how a large number of optical phenomena, particularly those of diffraction, were to be explained by that theory. Subsequently, too, though independently of Young, Fresnel showed that the phenomena of diffraction, and also those of polarisation, are explicable on the same theory, which since his time has been generally accepted.

511. Luminous, transparent, translucent, and opaque bodies.—*Luminous* bodies are those which emit light, such as the sun and ignited bodies. *Transparent* or *diaphanous* bodies are those which readily transmit light, and through which objects can be distinguished; water, gases, polished glass are of this kind. *Translucent* bodies transmit light, but objects cannot be distinguished through them; ground glass, oiled paper, &c., belong to this class. *Opaque* bodies do not transmit light; for example, wood, metals, &c. No bodies are quite opaque; they are all more or less translucent when cut in sufficiently thin leaves.

Foucault showed that when the object-glass of a telescope is thinly silvered, the layer is so transparent that the sun can be viewed through it without danger to the eyes, since the metallic surface reflects the greater part of the radiation which falls upon it.

512. Luminous ray and pencil.—A *luminous ray* is the direction of the line in which light is propagated; a *luminous pencil* is a collection of rays from the same source; it is said to be *parallel* when it is composed of parallel rays, *divergent* when the rays separate from each other, and *convergent* when they tend towards the same point. Every luminous body emits divergent rectilinear rays from all its points, and in all directions.

513. Propagation of light in a homogeneous medium.—A *medium* is any space or substance which light can traverse, such as a vacuum, air, water, glass, &c. A medium is said to be *homogeneous* when its chemical composition and density are the same in all parts, and to be *isotropic* when its properties at all points are the same in all directions; when this is not the case it is said to be *anisotropic* or *aeotropic*.

In every homogeneous medium light is propagated in a right line. For, if an opaque body is placed in the right line which joins the eye and the luminous body, the light is intercepted. The light which passes into a dark room by a small aperture is visible from the light falling on the particles of dust suspended in the atmosphere.

Light changes its direction on meeting an object which it cannot penetrate, or when it passes from one medium to another. These phenomena will be described under the heads *reflection* and *refraction*.

514. **Shadow, penumbra.**—When light falls upon an opaque body it cannot penetrate into the space immediately behind it, and this space is called the *shadow*.



Fig. 469

In determining the extent and the shape of a shadow projected by a body, two cases are to be distinguished: that in which the source of light is a single point, and that in which it is a body of any given extent.

In the first case, let S (fig. 469) be the luminous point, and M a spherical body which causes the shadow. If an infinitely long straight line, SG,

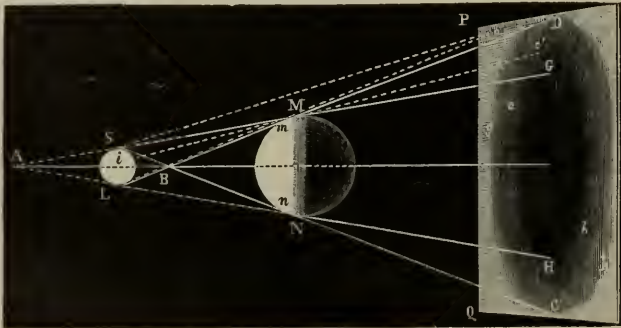

Fig. 470

moves round the sphere M tangentially, always passing through the point S, this line will trace a conical surface, which, beyond the sphere, separates that portion of space which is in shadow from that which is illuminated. In the present case, on placing a screen, PQ, behind the opaque body the limit of the shadow HG will be sharply defined. This is not, however, usually the case, for luminous bodies have always a certain magnitude, and are not mere luminous points.

Suppose that the luminous and illuminated bodies are two spheres, SL and MN (fig. 470). If an infinite straight line, AG, moves tangentially to both spheres, always cutting the line of centres in the point A, it will produce a conical surface with this point for a summit, and which traces behind the sphere MN a perfectly dark space MGHN. If a second right line, LD, which cuts the line of centres in B, moves tangentially to the two spheres, so as to produce a new conical surface, BDC, it will be seen that all the space outside this surface is illuminated, but that the part between the two conical surfaces is neither quite dark nor quite light. So that if a screen, PQ, is placed behind the opaque body, the central portion GH of the screen is quite in the shadow, while the annulus of breadth HC receives light from certain parts of the luminous body, and not from others. It is brighter than the true shadow, and not so bright as the rest of the screen, and it is accordingly called the *penumbra*.

Shadows such as these are *geometrical shadows*; *physical shadows*, or those which are really seen, are by no means so sharply defined. A certain quantity of light passes into the shadow, even when the source of light is a mere point, and conversely the shadow influences the illuminated part. This phenomenon, which will be afterwards described, is known by the name of *diffraction* (660).

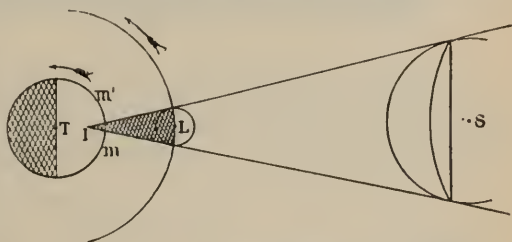

Fig. 471

The explanation of the phenomena of *eclipses* follows directly from the theory of shadows.

When the opaque disc of the moon comes, according to the conditions, between the sun and the earth, the shadow cast by the moon causes a more or less complete solar eclipse on those parts of the earth which it meets.

Let S be the sun, T the earth, and L the moon placed in a position favourable for an eclipse (fig. 471). If we can suppose the three bodies represented with their *relative* magnitudes and distances, we need only repeat the graphical construction of this figure to determine the dimensions of the cone of the shadow, and of the penumbra of the moon. The length LI of the cone of the shadow varies between 57 and 59 terrestrial radii, according to the relative positions of the earth and its satellite; the distance between the two planets varies between 55 and 62 such radii; hence, under favourable conditions the cone of the shadow may reach the earth, and in those points of the earth thus touched, *m*, there is a total eclipse of the sun. As this area has relatively a small extent, an eclipse which is visible by the inhabitants of this area is not seen by those in the neighbourhood. After the lapse of a time which never exceeds 3m. 13s. the cone will have left the place *m* and will pass to *m'*, which is not necessarily on the same parallel of latitude. It will thus sweep over the surface of the earth, in virtue of the special motion of the two heavenly bodies, along a line which astronomers can determine beforehand. On all points along this line

(fig. 472) there will successively be a total eclipse ; for adjacent ones, which are within the cone of the penumbra, the eclipse will be *partial*.

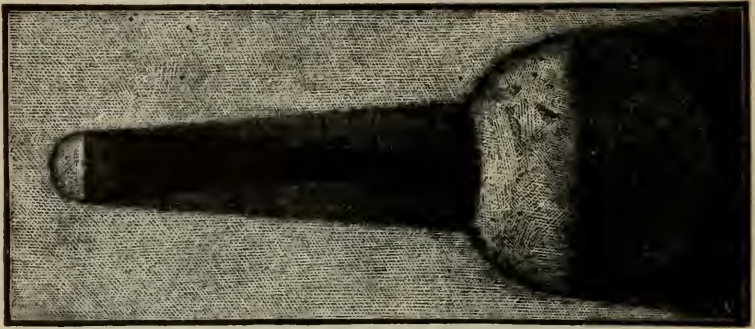

Fig. 472

If the cone of the shadow does not reach the earth, there will nowhere be a total eclipse ; but on a point m' (fig. 473) there will be no light from the central part of the sun ; this will then appear like a black circle surrounded by a bright ring (fig. 474), and forms what is called an *annular eclipse*.

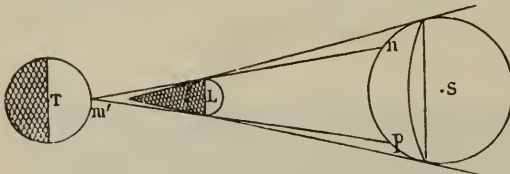

Fig. 473

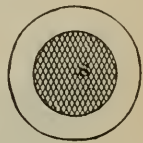

Fig. 474

Total or partial eclipses of the moon are produced by the total or partial immersion of the moon in the cone of the shadow cast by the earth ; for an observer on the moon they would constitute total or partial eclipses of the sun ; *total* at those parts of the moon in the shadow, *partial* at those in the penumbra.

The *transits* of Venus or of Mercury over the sun are phenomena of the same kind as eclipses, being produced by the projection on the earth of the penumbral cones of shadow of those planets. The eclipses of the satellites of certain planets such as Jupiter are identical with the eclipses of the moon.

515. **Images produced by small apertures.**—When rays of light which pass into a dark chamber through a *small* aperture are received upon a screen, they form images of external objects. These images are inverted ; their shape is always that of the external objects, and is independent of the shape of the aperture.

The inversion of the images arises from the fact that the luminous rays proceeding from external objects, and penetrating into the chamber, cross one another in passing the aperture, as shown in fig. 475. Continuing in a straight line, the rays from the higher parts meet the screen at the lower

parts, and conversely, those which come from the lower parts meet the higher parts of the screen. Hence the inversion of the image. The arrangement forms what is known as a *camera obscura*.

In order to show that the shape of the image is independent of that of the aperture, when the latter is sufficiently small and the screen at an adequate distance, imagine a triangular aperture, O (fig. 476), made in the door of a dark chamber, and let *ab* be a screen on which is received the image of a flame, AB. A divergent pencil from each point of the flame passes through

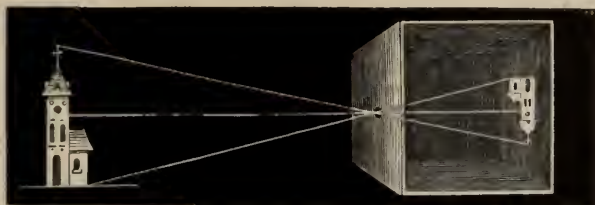

Fig. 475

the aperture, and forms on the screen a triangular image resembling the aperture. But the union of all these partial images produces a total image of the same form as the luminous object. For if we conceive that an infinite straight line moves round the aperture, with the condition that it is always tangential to the luminous object AB, and that the aperture is very small, the straight line describes two cones, the apex of which is the aperture, while one of the bases is the luminous object and the other the luminous object on the screen—that is, the image. Hence, if the screen is perpendicular to the right line joining the centre of the aperture and the centre



Fig. 476

of the luminous body, the image is similar to the body; but if the screen is oblique, the image is elongated in the direction of its obliquity. This is what is seen in the patches of light on the ground when solar light falls upon foliage; the rays of the sun passing through the minute interstices between the leaves produce images of the sun, which are either round or elliptical, according as the ground is perpendicular or oblique to the solar rays; and this is the case whatever be the shape of the aperture through which the light passes.

516. **Velocity of light.**—Light moves with such a velocity that at the surface of the earth there is, to ordinary observation, no appreciable interval between the occurrence of any luminous phenomenon and its perception by the eye. The knowledge that the velocity of light is not infinite was acquired as the result of astronomical observation. Römer, a Danish astronomer, in 1675, first deduced the velocity of light from observations of the eclipses of one of Jupiter's satellites.

Jupiter is a planet, round which five satellites revolve, as the moon does round the earth. In Römer's time only four were known. Of these the first, E (fig. 477) (we should now call it the second), suffers *occultation*—that is, passes into Jupiter's shadow—at equal intervals of time, which are 42h. 28m. 36s. Römer constructed a table giving the exact times at which occultations would occur for a year in advance, and compared the observed with the calculated times. While the earth, T, moves in that part of its orbit nearest Jupiter, its distance from that planet does not materially alter in 42 hours, and the intervals between two successive occultations of the

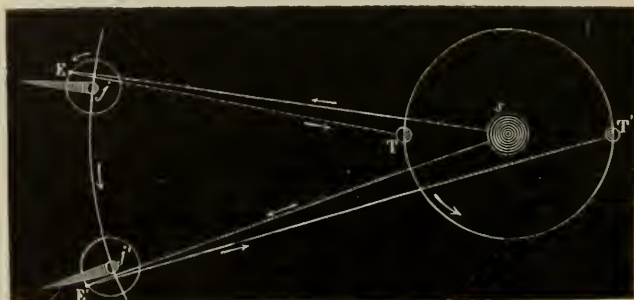

Fig. 477

satellite are approximately the same, that is, the observed occultation occurs at the predicted time; but, in proportion as the earth moves away in its revolution round the sun, s , the apparent interval between the moment when the occultation was expected and that at which it occurs increases, and when, at the end of six months, the earth has passed from the position T to the position T', a *total* retardation of 16m. 36s. is observed between the time at which the phenomenon is seen and that at which it is calculated to take place. But when the earth was in the position T, the sun's light reflected from the satellite E had to traverse the distance ET, while in the second position the light had to traverse the distance E'T'. This distance exceeds the first by the diameter of the earth's orbit. Consequently, light requires 16m. 36s. to travel the diameter TT' of the terrestrial orbit, or twice the distance of the earth from the sun, which gives for its velocity 190,000 miles in a second.

The stars nearest the earth are separated from it by at least 206,265 times the distance of the sun. Consequently, the light which they send requires more than three years to reach us. Those stars which are only visible

by means of the telescope are possibly at such a distance that thousands of years would be required for their light to reach our planetary system. They might have been extinguished for ages without our knowing it.

517. **Foucault's apparatus for determining the velocity of light.**—Notwithstanding the prodigious velocity of light Foucault succeeded in determining it experimentally by the aid of an ingenious apparatus, based on the use of the rotating mirror, which had been invented by Wheatstone for measuring the velocity of electricity.

In the description of this apparatus, a knowledge of the principal properties of mirrors and of lenses is presupposed. Fig. 478 represents the chief parts of Foucault's arrangement. The window shutter, K, of a dark chamber is perforated by a rectangular slit, behind which the platinum wire σ is stretched vertically. A beam of sunlight reflected from the outside by a mirror enters the dark room by the slit, meets the platinum

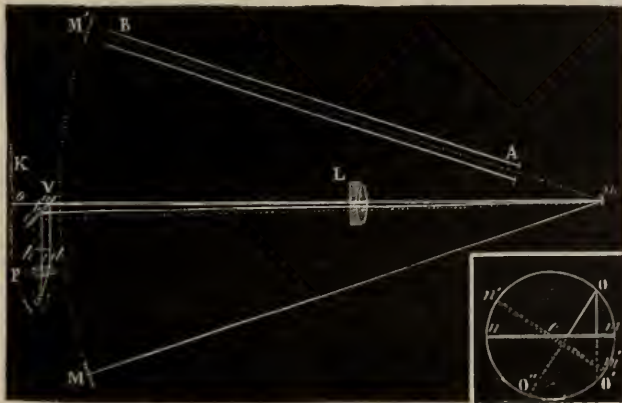

Fig. 478

Fig. 479

wire, and then traverses an achromatic lens, L, with a long focus placed at a distance from the platinum wire less than double its focal length. The image of the platinum wire, more or less magnified, would thus be formed on the axis of the lens; but the pencil of light, having traversed the lens, impinges on a plane mirror, m , rotating with great velocity; it is reflected from this, and forms in space an image of the platinum wire, which is displaced with an angular velocity double that of the mirror (530). This image is reflected by a concave mirror, M, whose centre of curvature coincides with the axis of rotation of the mirror m , and with its centre of figure. The pencil reflected from the mirror M returns upon itself, is again reflected from the mirror m , traverses the lens a second time, and forms an image of the platinum wire, which appears on the wire itself so long as the mirror m is at rest or turns slowly.

In order to see this image without hiding the pencil of light which enters by the aperture in K, a thin plate of unsilvered glass, V, is placed between

the lens and the wire, and is inclined so that the reflected rays fall upon a powerful eyepiece, P.

The apparatus being arranged, if the mirror m is at rest, the pencil after meeting M is reflected to m , and thence returns along its former path, till it meets the glass plate V in a , and being partially reflected, forms at d —the distance ad being equal to ao —an image of the wire, which the eye is enabled to observe by means of the eyepiece, P. If the mirror m , instead of being fixed, is moving slowly round—its axis being at right angles to the plane of the paper—there will be no sensible change in its position during the brief interval elapsing while light travels from m to M and back again, but the image will alternately disappear and reappear. If now the velocity of m is increased to upwards of 30 turns per second, the interval between the disappearance and reappearance is so short that the impression on the eye is persistent, and the image appears perfectly steady.

Lastly, if the mirror turns with sufficient velocity, there is an appreciable displacement of the image, owing to the fact that now the mirror m has moved through a small angle during the time the light took to travel from it to M and back again; the return ray, after its reflection from the mirror m , takes the direction mb , and forms its image at i ; that is, the image has undergone a total displacement di . Speaking precisely, there is a deviation of the ray as soon as the mirror turns, even slowly; but it is only appreciable when the velocity of rotation is sufficiently rapid, or the distance Mm sufficiently great, for the deviation necessarily increases with the time which the light takes in traversing $2mM$. In Foucault's experiment the distance Mm was only $13\frac{1}{2}$ feet; when the mirror rotated with a velocity of 600 to 800 turns in a second, displacements of 0.2 to 0.3 mm. were obtained.

Taking $Mm = l$, $Lm = l'$, $oL = r$, and representing by n the number of turns in a second, by δ the observed displacement of the image of the wire, and by V the velocity of light, Foucault arrived at the formula

$$V = \frac{8\pi l^2 nr}{\delta(l + l')}$$

from which the velocity of light is calculated at 185,157 miles in a second; this number agrees remarkably well with the value deduced from newer determinations of the value of the solar parallax.

The mechanism by which the mirror was turned consisted of a small steam turbine, bearing a sort of resemblance to the siren, and, like that instrument, giving a higher sound as the rotation is more rapid: in fact, it is by the pitch of the note that the velocity of the rotation is determined.

In this apparatus liquids can be experimented upon. For that purpose a tube, AB, 10 feet long, and filled with distilled water, is placed between the turning mirror m , and a concave mirror M' , identical with the mirror M. The luminous rays reflected by the rotating mirror, in the direction mM' , traverse the column of water AB twice before returning to V. But the return ray then becomes reflected at c , and forms its image at h : the displacement is consequently greater for rays which have traversed water than for those which have passed through air alone; hence the velocity of light is less in water than in air.

This is the most important part of these experiments. It is a necessary

consequence of the undulatory theory that the velocity of light must be less in the more highly refracting medium (652), while the opposite is a necessary consequence of the emission theory. Hence Foucault's experiment may be regarded as a crucial test of the validity of the undulatory theory.

518. **Experiments of Fizeau.**—In 1849 Fizeau measured directly the velocity of light, by ascertaining the time it took to travel from Suresnes to Montmartre and back again. The apparatus employed was a toothed wheel, capable of being turned with great and measurable angular velocity. The teeth were made of precisely the same width as the intervals between them. The apparatus being placed at Suresnes, a pencil of rays was transmitted through an interval between two teeth to a mirror placed at Montmartre. The pencil, directed by a properly arranged system of lenses, returned to the wheel. As long as the apparatus was at rest the pencil returned exactly through the same interval as that through which it first set out. But when the wheel was turned sufficiently fast, a tooth was made to take the place of an interval, and the ray was intercepted. As the wheel was turned still more rapidly, the light reappeared when the interval between the next two teeth had taken the place of the former tooth at the instant of the return of the pencil.

The distance between the two stations was 28,334 feet. From a knowledge of this distance, the dimensions of the wheel, its velocity of rotation, &c., Fizeau found the velocity of light to be 196,000 miles per second—a result agreeing with that given by astronomical observation as closely as can be expected in a determination of this kind.

Cornu subsequently investigated the velocity of light by Fizeau's method, but with improvements so that the probable error did not exceed $\frac{1}{400}$ of the total amount; the two stations, which were 6.4 miles apart, were a pavilion of the École Polytechnique and a room in the barracks of Mont Valérien. By means of electro-magnetic arrangements the rotation of the toothed disc, and the times of obscuration and illumination, were registered on a blackened cylinder, on the principle of the method described in art. 245. Cornu thus obtained the number 185,420 miles—a result closely agreeing with that of Foucault, and supported by calculations based on the results of astronomical observations of the transit of Venus in 1874.

Newcomb improved Foucault's method by using a slightly concave mirror instead of a plane one, by which the image of the slit was brighter; it was observed by a telescope through a distance of 4000 metres. The rotations also were reversed, by which the angle between the two positions of the telescope was observed with greater accuracy; he thus obtained the number 186,364 miles, while Michelson repeated a former determination and found 186,354, a difference of only about 10 miles. In metric units the velocity of light is 300,000 kilometres per second, or 3×10^{10} cm./sec.

519. **Laws of the intensity of light.**—The *intensity* of illumination is the quantity of light received on the unit of surface; it is subject to the following laws:—

1. *The intensity of illumination on a given surface due to a point-source of light is inversely as the square of its distance from the source.*

II. *The intensity of illumination which is received obliquely is proportional to the cosine of the angle which the luminous rays make with the normal to the illuminated surface.*

In order to demonstrate the first law, let there be two circular screens, CD and AB (fig. 480), one placed at a certain distance from a source of light, L, regarded as a point, and the other at double this distance, and let s and S be the areas of the two screens. If a be the total quantity of light which is emitted by the source in the direction of the cone ALB, the intensity of the light on the screen CD—that is, the quantity which falls on the unit of surface—is $\frac{a}{s}$, and the intensity on the screen AB is $\frac{a}{S}$.



Fig. 480

Now as the triangles ALB and CLD are similar, the diameter of AB is double that of CD ; and as the surfaces of circles are as the squares of their diameters, the surface S is four times s , consequently the intensity $\frac{a}{S}$ is one-fourth that of $\frac{a}{s}$.

Fig. 480 shows that it is owing to the divergence of the luminous rays emitted from the same source that the intensity of light is inversely as the square of the distance ; the illumination of a surface placed in a beam of parallel luminous rays is the same at all distances in a vacuum. In air and in other transparent media the intensity of light decreases, in consequence of absorption, more rapidly than the square of the distance.

The second law of intensity corresponds to the law which we have found to prevail for heat : it may be theoretically deduced as follows :—Let DA,

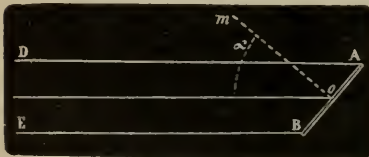

Fig. 481

EB (fig. 481) be a pencil of parallel rays falling obliquely on a surface, AB, and let om be the normal to this surface. If S is the section of the pencil, a the total quantity of light which falls on the surface AB, and I that which falls on the unit of surface—that is, the intensity of illumination—we have $I = \frac{a}{AB}$. But

as S is only the projection of AB on a plane perpendicular to the pencil, we know from trigonometry that $S = AB \cos \alpha$, from which $AB = \frac{S}{\cos \alpha}$. This value substituted in the above equation gives $I = \frac{a}{S} \cos \alpha$; a formula which demonstrates the law of the cosine, for as a and S are constant quantities, I is proportional to $\cos \alpha$.

The law of the cosine applies also to rays emitted obliquely by a luminous surface; that is, the rays are less intense in proportion as they are more inclined to the surface which emits them. In this respect they correspond to the third law of the intensity of radiant heat (420).

520. **Photometers.**—A *photometer* is an apparatus for measuring the relative illuminating powers of different sources of light.

The illuminating power of a source is the quantity of light received by unit area at unit distance from the source, the rays falling perpendicularly on the area.

Rumford's photometer.—This consists of a ground-glass screen, in front of which is fixed an opaque rod (fig. 482); the lights to be compared—for instance, a lamp and a candle—are placed at a certain distance in such a manner that each projects on the screen a shadow of the rod. The shadows thus projected are at first of unequal intensity, but by altering the position of the lamp it may be so placed that the intensity of the two shadows is the same. Then, since the shadow thrown by the lamp is illuminated by the

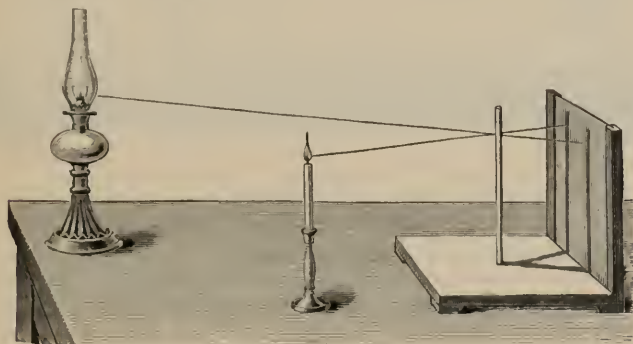

Fig. 482

candle, and that thrown by the candle is illuminated by the lamp, the illumination of the screen due to each light is the same. The illuminating powers of the two sources—that is, the illuminations which they would give at equal distances—are then directly proportional to the squares of their distances from the shadows; that is to say, if the lamp is three times the distance of the candle, its illuminating power is nine times as great.

For if i and i' are the illuminating powers of lamp and candle respectively and d and d' their distances from the shadows, it follows, from the first law of the intensity of light, that the amount of light received from the lamp at the distance d is $\frac{i}{d^2}$ and that from the candle $\frac{i'}{d'^2}$ at the distance d' .

On the screen these are equal; hence $\frac{i}{d^2} = \frac{i'}{d'^2}$ or $\frac{i}{i'} = \frac{d^2}{d'^2}$ which was to be proved.

Bunsen's photometer.—When a grease-spot is made on a piece of bibulous paper, if the paper is illuminated by a light placed in front, the spot appears darker than the surrounding space; if, on the contrary, it is

illuminated from behind, the spot appears light on a dark ground. If the greased part and the rest appear unchanged, the illumination on both sides is the same. Bunsen's photometer depends on an application of this principle. Its essential features are represented in fig. 483. A circular spot is made on a paper screen by means of a solution of spermaceti in naphtha : on one side of this is placed a light of a certain intensity, which serves as a standard ; in London it is a sperm candle $\frac{7}{8}$ of an inch in diameter, and burning 120 grains in an hour. The light to be tested—a petroleum lamp, or a gas burner consuming a certain volume of gas in a given time—is then moved in a right line to such a distance on the other side of the screen that there is no difference in brightness between the greased part and the rest of the screen. By measuring the distances of the lights from the screen

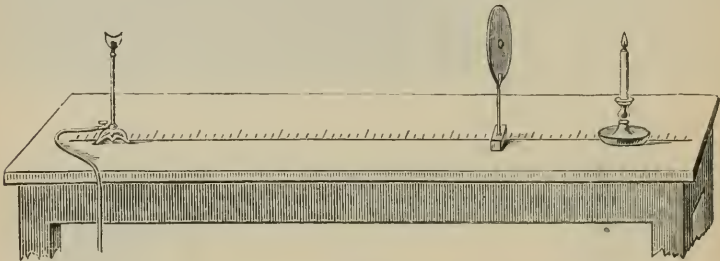

Fig. 483

by means of the scale, their relative illuminating powers are respectively as the squares of their distances from the screen.

The difficulty of constructing candles capable of giving a light sufficiently uniform for standard purposes has led Harcourt to adopt as unit the light formed by burning a mixture of 7 volumes of pentane gas and 20 volumes of air, at the rate of half a cubic foot in an hour, in a specially constructed burner so as to produce a flame of a definite height. This has been found to answer well in practice. By this kind of determination the degree of accuracy which can be attained is not so great as in many physical determinations, more especially when the lights to be compared are of different colours ; one, for instance, yellow, and the other of a bluish tint.

In Germany a paraffin candle 2 centimetres in diameter, and having a flame 5 centimetres high, or a Hefner Alteneck lamp equal to 1·2 candles, is much used as standard ; the combustible in the lamp is amylic acetate or artificial pear oil, and a flame of constant height is produced in a burner of special construction. The French Carcel lamp is equal to 9·2 candles.

The absolute unit of light adopted by the International Congress of Electricians in 1884, proposed by M. Violle, is that emitted by a square centimetre of melted platinum at the moment of its solidification. It is equal to about 15 standard candles.

Wheatstone's photometer.—The principal part of this instrument is a steel bead P (fig. 484), fixed on the edge of a disc, which rotates on a pinion, o, working in a larger toothed wheel. The wheel fits in a cylindrical

brass box which is held in one hand, while the other works a handle, A, which turns a central axis, the motion of which is transmitted by a spoke *a*, to the pinion *o*. In this way the latter turns on itself, and at the same time revolves round the circumference of the box; the bead shares the double motion and consequently describes a curve in the form of a rose [fig. 485].

Now, let M and N be the two lights whose intensities are to be compared; the photometer is placed between them and rapidly rotated. The brilliant points produced by the reflection of the light on the two opposite sides of the beads give rise to two luminous bands, arranged as represented in fig. 485. If one of them is more brilliant than the other—that which proceeds from the light M, for instance—the instrument is brought nearer the other light



Fig. 484

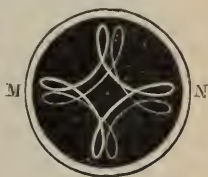

Fig. 485

until the two bands exhibit the same brightness. The distance of the photometer from each of the two lights being then measured, their candle-powers are proportional to the squares of the distances.

521. **Relative intensities of various sources of light.**—The light of the sun is 600,000 times as powerful as that of the moon; and 16,000,000,000 times as powerful as that of *a Centauri*, the third in brightness of all the stars. The moon is thus 27,000 times as bright as this star; the sun is 5,500 million times as bright as Jupiter, and 80 billion times as bright as Neptune. Its light is estimated to be equal to 670,000 times that of a wax candle at a distance of 1 foot.

The relative luminosities of the following stars are as compared with Vega = 1: Pole Star 0.13, Aldebaran 0.30, Saturn 0.47, Arcturus 0.79, Mars 2.93, Sirius 4.291, Jupiter 8.24, Venus 38.9.

A difference in the strength of light or shadow is perceived when the duller light is $\frac{5}{8}$ of the brightness of the other, and both are near together, especially when the shadow is moved about.

Our requirements as regards illumination are constantly on the increase; thus for public receptions of a state character in recent times in Paris, a number of lamps was used corresponding to over 13 candles per square yard, which is six times as much as was used on the occasion of the marriage of the Dauphin in 1745; the former, however, is still far removed from perfect illumination, that of daylight, which is estimated at about 180 candles per square yard.

CHAPTER II

REFLECTION OF LIGHT. MIRRORS

522. **Laws of the reflection of light.**—When a ray of light meets a polished surface, it is reflected according to the two following laws, which, as we have seen, also hold for heat.

I. *The angle of reflection is equal to the angle of incidence.*

II. *The incident and the reflected ray are both in the same plane, which is perpendicular to the reflecting surface.*

The words are here used in the same sense as in art. 423, and need no further explanation.

First-proof.—The two laws may be demonstrated by the apparatus represented in fig. 486. It consists of a graduated circle in a vertical plane.

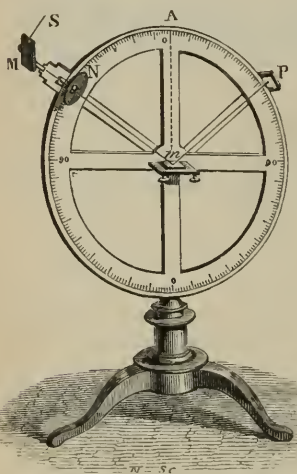

Fig. 486

Two brass slides move round the circumference; on one of them there is a piece of ground glass, P, and on the other an opaque screen, N, in the centre of which is a small aperture. Fixed to the latter slide there is also a mirror, M, which can be more or less inclined, but always remains in a plane perpendicular to the plane of the graduated circle. Lastly, there is a small polished metallic mirror, *m*, placed horizontally in the centre of the circle.

In making the experiment, a pencil of solar or any suitable artificial light, S, is caused to fall on the mirror, M, which is so inclined that the reflected light passes through the aperture in N, and falls on the centre of the mirror, *m*. The luminous pencil then experiences a second reflection in a direction *mP*, which is ascertained by moving

P until an image of the aperture is found in its centre. The number of degrees comprised in the arc AN is then read off, and likewise that in AP; these being equal, it follows that the angle of reflection $\angle mNP$ is equal to the angle of incidence $\angle ANM$.

The second law follows from the arrangement of the apparatus, the plane of the rays *Mm* and *mP* being parallel to the plane of the graduated circle, and consequently perpendicular to the mirror *m*.

Second proof.—The law of the reflection of light may also be demonstrated by the following experiment, which is susceptible of greater accuracy than

that just described:—In the centre of a graduated circle, M (fig. 487), placed in a vertical position, there is a small telescope movable in a plane parallel to the limb; at a suitable distance there is a vessel D full of mercury, which forms a perfectly horizontal plane mirror. Some particular star of the first or second magnitude is viewed through the telescope in the direction AE, and the telescope is then inclined so as to receive the ray AD coming from the star after being reflected from the brilliant surface of the mercury.

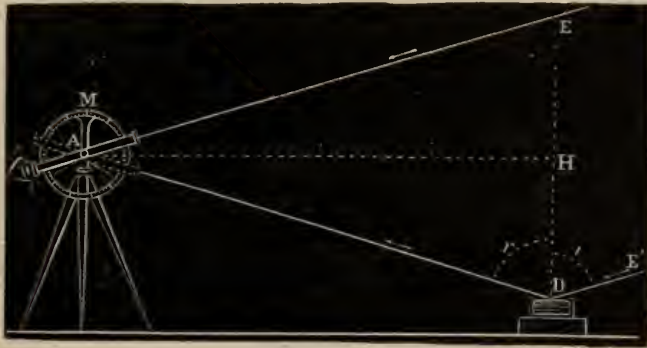

Fig. 487

In this way the two angles formed by the rays EA and DA, with the horizontal AH, are found to be equal, from which it may easily be shown that the angle of incidence $E'DE$ is equal to the angle of reflection EDA. For if DE is the normal to the surface of the mercury, it is perpendicular to AH, and AED, ADE are the complements of the equal angles EAH, DAH: therefore AED, ADE are equal; but the two rays AE and DE' may be considered parallel, in consequence of the great distance of the star, and therefore the angles EDE' and DEA are equal, for they are alternate angles, and consequently the angle $E'DE$ is equal to the angle EDA.

REFLECTION OF LIGHT FROM PLANE SURFACES

523. Mirrors. Images.—*Mirrors* are bodies with polished surfaces which show by reflection objects presented to them. According to their shape, mirrors are divided into *plane*, *spherical* (*concave* and *convex*), *parabolic*, *conical*, &c.

Rays of light diverging from any point of the object and falling upon a mirror are caused by reflection either to converge to, or to appear to diverge from, a second point. In either case the second point is called the image of the first point.

524. Formation of images by plane mirrors.—The determination of the position and size of images resolves itself into investigating the images of a series of points. And first, the case of a single point, A, placed in front of a plane mirror, MN (fig. 488), will be considered. Any ray, AB, incident from this point on the mirror is reflected in the direction BO, making the angle of reflection DBO equal to the angle of incidence DBA.

If now a perpendicular, AN , be let fall from the point A on the mirror, and if the ray OB be prolonged below the mirror until it meets this perpendicular in the point a , two triangles are formed, ABN and BNa , which are equal, for they have the side BN common to both, and the angles ANB , ABN , equal to the angles aNB , aBN ; for the angles ANB and aNB are right angles, and the angles ABN and aBN are each equal to the angle OBN . From the equality of these triangles, it follows that aN is equal to AN ; that is, that any ray, AB , takes such a direction after being reflected, that its prolongation below the mirror cuts the perpendicular Aa in the point a , which is at the same distance from the mirror as the point A . This applies also to the case of any other ray from the point A ; AC , for example.



Fig. 488

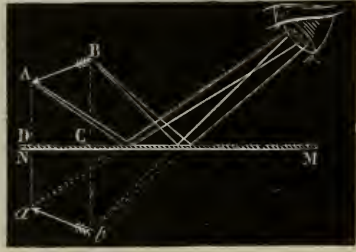

Fig. 489

From this the important consequence follows, that all rays from the point A , reflected from the mirror, follow, after reflection, the same direction as if they had all proceeded from the point a . The eye is deceived, and sees a reproduction of the point A at a , as if it were really situated at a . Hence in plane mirrors the image of any point is formed behind the mirror at a distance equal to that of the given point, and on the perpendicular let fall from this point on the mirror.

It is manifest that the image of any object will be obtained by constructing, according to this rule, the image of each of its points, or, at least, of those which are sufficient to determine its form. Fig. 489 shows how the image ab of any object, AB , is formed.

It follows from this construction that in plane mirrors the image is of the same size as the object; for if the trapezium $ABCD$ be applied to the trapezium $DCab$, they are seen to coincide, and the object AB agrees with its image. A further consequence is, that in plane mirrors the image is symmetrical in reference to the object, and not inverted.

525. **Virtual and real images.**—There are two cases relative to the direction of rays reflected by mirrors according as the rays after reflection are convergent or divergent. In the latter case the reflected rays do not meet, but if they are supposed to be produced on the other side of the mirror, their prolongations meet in the same point, as shown in figs. 488 and 489. The eye is then affected just as if the rays proceeded from this point, and it sees an image. But the image has no real existence, the luminous rays do not come from the other side of the mirror: this appearance is called the *virtual image*. The images of real objects produced by plane mirrors are of this kind.

In the second case, where the reflected rays converge, as we shall soon see in concave mirrors, the rays meet at a point in front of the mirror and on the same side as the object. They form there an image called the *real image*, for it can be received on a screen. The distinction may be expressed by saying that *real images are those formed by the reflected rays themselves, and virtual images those formed by their prolongations.*

526. **Multiple images from two plane mirrors.**—When an object is placed between two plane mirrors, which form an angle with each other,

either right or acute, images of the object are formed, the number of which increases with the inclination of the mirrors. If they are at right angles to each other, three images are seen, arranged as represented in fig. 490.

The rays OC and OD from the point O, after a single reflection, give the one an image O', and the other an image O'', while the ray OA, which has undergone two reflections at A and B, gives the third image O'''.

When the angle of the mirrors is 60°, five images are produced, and seven if it is 45°. The number of images continues to increase in proportion as the angle diminishes, and when it is zero—that is, when the mirrors are parallel—the number of images is theoretically infinite.

In general, if two mirrors are inclined to each other at an angle which is an exact submultiple of 180° (e.g. 30°, 45°, 60°, 90°), the number of images they produce—counting for this purpose the object as one image—is equal to the number of times the angle between them is contained in 360.

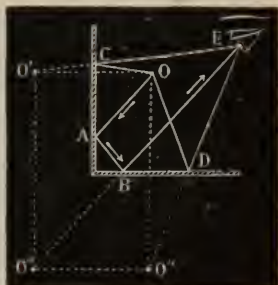

Fig. 490

The *kaleidoscope*, invented by Sir D. Brewster, depends on this property of inclined mirrors. It consists of a tube, in which are three mirrors inclined at 60°, or sometimes two inclined at 30°; one end of the tube is closed by a piece of ground glass, and the other by a cap provided with

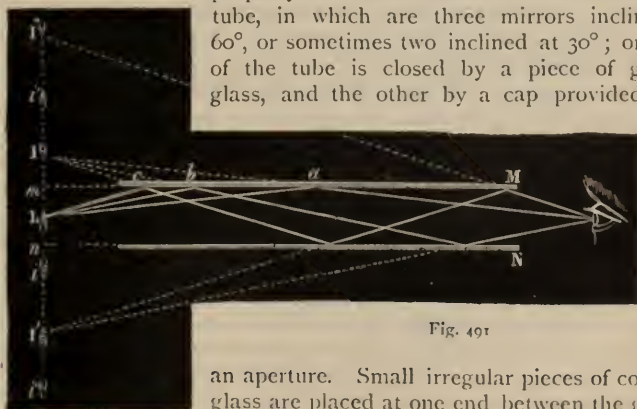

Fig. 491

an aperture. Small irregular pieces of coloured glass are placed at one end between the ground glass and another glass disc, and when looked

through the aperture, the other end being held towards the light, the objects and their images are seen arranged in beautiful symmetrical forms;

by turning the tube, an almost endless variety of these shapes is obtained.

527. **Multiple images in two plane parallel mirrors.**—In this case the number of images of an object placed between them is theoretically infinite. Physically the number is limited, for as the incident light is never totally reflected, some of it being always absorbed, the images gradually become fainter, and are ultimately quite extinguished.

Fig. 491 shows how the pencil La reflected once from M gives at I the image of the object L at a distance $mI = mL$; then the pencil Lb reflected once from the mirror M , and once from N , furnishes the image I' at a distance $nI' = nI$; in like manner the pencil Lc , after two reflections on M , and one on N , forms the image I'' at a distance $mI'' = mI'$, and so on for an infinite series. The images i, i', i'' are formed in the same manner by rays of light which, emitted by the object L , fall first on the mirror N . Each virtual image formed by one mirror acts as a real object towards the other mirror.

528. **Irregular reflection. Diffused light.**—The reflection from the surfaces of polished bodies, the laws of which have been just stated, is called the *regular* or *specular reflection*; but the quantity thus reflected is less than that of the incident light. The light incident on an opaque body separates, in fact, into three parts: one is reflected *regularly*; another *irregularly*—that is, in all directions; while a third is extinguished, or *absorbed* by the reflecting body. If light falls on a transparent body, a considerable portion is transmitted with regularity.

The irregularly reflected light is called *scattered* or *diffused light*: it is that which makes bodies visible. The light which is reflected regularly does not give us the image of the reflecting surface, but that of the body from which the light proceeds. If, for example, a beam of sunlight is incident on a well-polished mirror in a dark room, the more perfectly the light is reflected the less visible is the mirror in the different parts of the room. The eye does not perceive the image of the mirror, but that of the sun. If the reflecting power of the mirror is diminished by sprinkling on it a light powder, the sun's image becomes feebler, and the mirror is visible from all parts of the room. Perfectly smooth, polished reflecting surfaces, if such there were, would be invisible. The beam of light itself is only seen in the room owing to irregular reflections from the particles of dust, and the like, which are floating in the air. Tyndall showed that when this floating matter in the air in an enclosed space is completely removed, the beam of sunlight or the electric light is quite invisible. The atmosphere diffuses the light which falls on it from the sun in all directions, so that it is light in places which do not receive the direct rays of the sun. Thus, the upper layers of the air diffuse the light which they receive before sunrise and after sunset, and accordingly give rise to the phenomena of *twilight*.

529. **Intensity of reflected light.**—The intensity of the light reflected is always less than that of the incident light, for some of the latter is absorbed by the reflecting body. The amount of reflected light increases with the obliquity of the incident beam. For instance, if a sheet of white paper is placed before a candle, and is looked at very obliquely, an image of the flame is seen by reflection, which is not the case if the eye receives less oblique rays.

The quantity of the reflected light varies with different bodies, even when the degree of polish and the angle of incidence are the same. Thus with perpendicular incidence, the light reflected from a metal mirror is $\frac{2}{3}$ of the incident light, $\frac{3}{4}$ from mercury, $\frac{1}{25}$ from glass, and $\frac{1}{50}$ from water. It also varies with the nature of the medium which the ray is traversing before and after reflection. Polished glass immersed in water loses a great part of its reflecting power.

In the case of scattered reflection the actual lustre or brightness of an illuminated surface is only a fraction of the light which falls upon it, and depends on the nature of the surface. If we call the incident light 100, we have for the brightness of freshly fallen snow 78, white paper 70, white sandstone 24, porphyry 11, and ordinary earth 8.

530. **Reflection of a ray of light in a rotating mirror.**—When a horizontal ray of light falls on a plane mirror which can rotate about an axis, if the mirror is turned through any angle, the reflected ray is turned through double the angle.

Let mm (fig. 492) be the first position of the mirror, $n'n'$ its position after it has been turned through the angle a ; and let OD be the fixed incident ray. Suppose that at first the incident ray falls normally on the mirror; the corresponding reflected ray will be along DO . When the mirror has turned through an angle a , its normal, DM , will have turned through the same angle, and the reflected ray DA through $2a$. The statement which is here shown to be true in a particular case may be proved true generally.



Fig. 492

531. **The sextant.**—This instrument is used to measure the angular distance of any two distant objects; its principle is as follows. Suppose A (fig. 493) is a small mirror half silvered, so that the eye at B' can see through the free part. B is a second mirror which can turn about an axis at right angles to the plane of the figure. When its plane is parallel to that of A , the ray EB of a distant object, which we will call L , is reflected from B to A , so that the eye sees the distant object L both directly through the unsilvered part of A , and also by reflection from the silvered mirrors B and A , L being assumed to be so distant that E, B' and EB are parallel. If B is not parallel to A , but in the position represented by the shading, the eye receives rays not from E but from some other object, L' , in the direction BF .

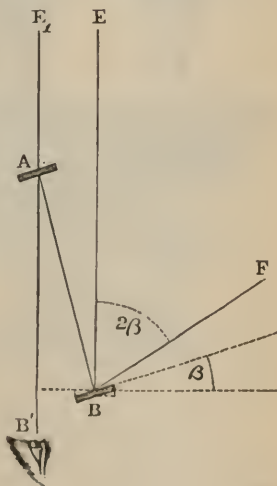

Fig. 493

If β is the angle through which the mirror B has been turned, the angular distance between L and L' is 2β (530). Thus the angular distance between any two distant objects is determined by turning the mirror B through such an angle that the eye looking along B'A sees one object directly and the other by reflection from the two mirrors.

Fig. 494 represents one form of sextant which derives its name from the fact, that only one sixth of the circle is used. It consists of a graduated metal sector AA, on which plays the index arm F; this is provided with a vernier and a micrometer screw by which the index may be accurately adjusted and also clamped; G is a lens for reading the vernier. The mirror B, which is called the *index glass*, is rigidly fixed to the arm BF and moves with it. The telescope DE is fixed to one arm as shown, and on the other arm opposite is the *horizon glass* C, also rigidly fixed, the lower half of which is silvered. The axis of the telescope just traverses the boundary of the silvered and unsilvered part of the mirror. K and L are dark glasses, turning about hinges *b* and *c*, for shading off the sun's light.

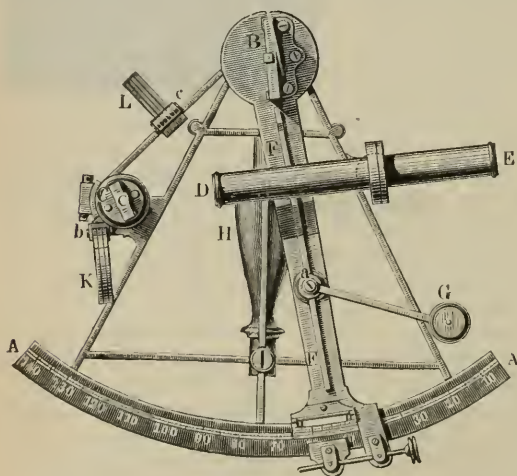

Fig. 494

In making an observation the sextant is held by the handle, H, so that its plane passes through both the objects whose angular distance is to be measured. The index arm being at the zero of the graduation, the two mirrors are parallel. One of the objects, a point on the horizon for instance, is viewed through the telescope and the unsilvered part of the mirror C. The index arm is then moved until the eye sees simultaneously with this the image of

another body, the sun or a star for example, which reaches the eye after successive reflections from the mirror B, and from the silvered part of the mirror C. The angle between the two is twice the angle through which the index arm has been turned, and is read off directly from the graduated arc, 60° on the arc being graduated as 120° .

A great advantage of this instrument is that a slight agitation does not affect the measurement of the angle; it can accordingly be used on ship-board, is indispensable for use at sea, and in travelling where the use of a stand is objectionable.

532. **Measurement of small angles by reflection from a mirror.**—An important application of the laws of reflection in measuring small angles of deflection in magnetic and other observations was first made by Gauss.

The principle of this method will be understood from fig. 495, in which AO represents a telescope, underneath which, and at right angles to its axis, is fixed a graduated scale *ss*; the centre of which, the zero, corresponds to the axis of the telescope.

Let NS be the object whose angular deflection is to be measured, a magnet for instance, and let *mm* represent a small plane mirror fixed at right angles to the axis of the magnet.

If now, at the beginning of the observation, the telescope is adjusted so that the image of the zero appears coincident with the cross-wires, its axis is perpendicular to the mirror. Now when the mirror is turned, by whatever cause, through an angle *a*, the eye will see, through the tele-

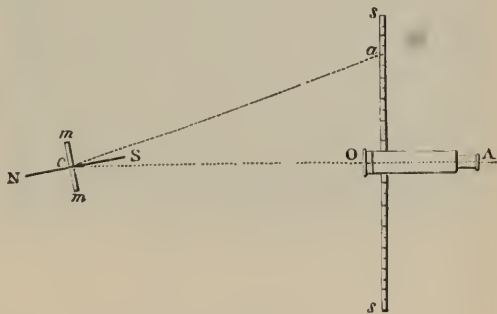

Fig. 495

scope, the image of another division of the scale, *a* for instance, the ray proceeding from which makes with the line *cOA* the angle $2a$.

From the distance of this division *Oa* from the zero of the scale and the distance *Oc* from the mirror we have $\tan 2a = \frac{Oa}{Oc}$. Thus, for instance, if *Oa*

is 12 millimetres and *Oc* 5000 millimetres, then $\tan 2a = \frac{12}{5000}$, from which $2a = 8' 15''$. As a practised eye can easily read $\frac{1}{10}$ of a millimetre, it is possible by such an arrangement to read off an angular deflection of two seconds.

Another plan for reading the small angle through which a suspended magnet or other rotating body moves, is to replace the telescope by an oil or glow lamp, and the plane mirror by a concave spherical mirror. The light of the lamp passes through a circular aperture across which a vertical fine wire is drawn, and the mirror produces a sharp image of the illuminated wire on a graduated scale, which is generally placed immediately above the aperture. Such a lamp and scale are illustrated in fig. 496.

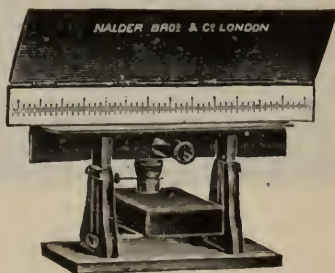

Fig. 496

533. **Mance's heliograph.**—The reflection of light from mirrors has been applied by Sir H. Mance in signalling at great distances by means of the sun's light.

The apparatus consists essentially of a mirror about 4 inches in diameter mounted on a tripod, and provided with suitable adjustments, so that the sun's light can be received upon it and reflected to a distant station. An

observer then can see through a telescope the reflection of the sun's rays as a spot of light. The mirror has an adjustment by which it can be made to follow the sun in its apparent motion. There is also a lever key by which the signaller, after directing the reflected beam to a distant station, can obstruct the light for longer or shorter intervals and thus communicate messages by the Morse code (914).

The heliograph has proved of essential service in the campaigns in Afghanistan and South Africa. Instead of any special form of apparatus, an ordinary shaving mirror or hand-glass is frequently used; and the proper inclination having been given so as to send the sun's rays to the distant station, which is very easily effected, the signals are produced by obscuring the mirror by sliding a piece of paper over it for varying lengths of time. In this way longer or shorter flashes of light are produced, which, properly combined, form the alphabet.

Of course this mode of signalling can only be used where the sun's light is available, but it has the advantage of being cheap, simple, and portable. Signals have been sent at the rate of twelve words a minute, through distances, in very fine weather, of forty miles.

REFLECTION OF LIGHT FROM CURVED SURFACES

534. **Spherical mirrors.**—It has been already stated (523) that there are several kinds of curved mirrors; those most frequently employed are spherical and parabolic mirrors.

Spherical mirrors are those whose curvature is that of a sphere; their surface may be supposed to be formed by the revolution of an arc MN (fig. 497) about the radius CA, which unites the middle of the arc to the centre of the circle of which it is a part. According as the reflection takes

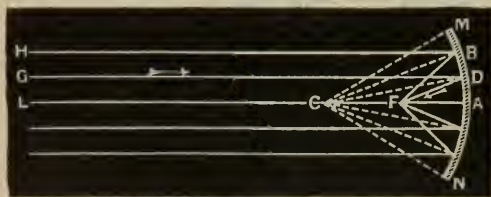

Fig. 497

place from its internal or from its external face, the mirror is said to be *concave* or *convex*. C, the centre of the hollow sphere of which the mirror forms part, is called the *centre of curvature*: the point A is the centre of the mirror. The infinite right line AL, which passes through A and C, is the *principal axis* of the mirror; any right line which simply passes through the centre C, and not through the point A, is a *secondary axis*. The angle MCN, formed by joining the centre and extremities of the mirror, is the *aperture*. A *principal section* is the section made by a plane through its principal axis. In speaking of mirrors those lines alone will be considered which lie in the same principal section.

535. **Reflection from a concave spherical mirror.**—We shall first take the case when the object is a luminous point situated at L (fig. 498), on the principal axis of the mirror. Of the rays which proceed from L, some fall upon the mirror and are reflected; the reflected rays, if we consider only

those which strike the mirror in the neighbourhood of A, the centre of the mirror, meet in a point which is the image of the point L. Since a point is determined by the intersection of two lines, it is only necessary to draw two incident rays from L and find out the point where the corresponding reflected rays meet.

Let one of the two rays be that which passes through the centre of curvature, C, of the mirror; this strikes the mirror normally at A and is reflected along its original path, so that AL is the reflected ray corresponding to the incident ray LA.



Fig. 498

Draw any other incident ray, LI; join IC, and make the angle CIl equal to the angle CIL, and let Il meet AL in the point l; then l is the image of L. All other rays from L will, after reflection from the mirror, pass approximately through l, provided the aperture of the mirror be small.

L and l are called *conjugate points* or *conjugate foci*: for there is this connection between them, that if l is the source of light, L will be its image, that is, will be the point to which rays after reflection will converge.

We will now obtain a numerical relation between the distances of L and l from the mirror.

Let $AL = p$, $Al = p'$, and $AC = r$; then, since in the triangle LIl the angle at I is bisected by IC, we have by geometry $LI : Il = LC : Cl = p - r : r - p'$. Now, Il is greater than Al; but if I be taken very near to A—that is, if we consider only those rays which are close to the principal axis—we may assume Il and Al to be equal, and also IL and AL. Thus the equation above becomes $AL : Al = p - r : r - p'$, or $p : p' = p - r : r - p$; whence $p(r - p) = p'(p - r)$, or $pr + p'r = 2pp'$, and dividing by $pp'r$, $\frac{1}{p} + \frac{1}{p'} = \frac{2}{r}$

This formula enables us to find the position of l when that of L is known.

Let us now consider how the point l moves when the source L is placed in different positions. If L moves away from the mirror along the axis, the angle of incidence LIC increases, and therefore the angle CIl increases also, that is, l moves towards the mirror; this is seen also from the formula, for, since $\frac{1}{p} + \frac{1}{p'}$ is constant, if p increases, p' must diminish. Suppose L to be removed to an infinite distance, then p is infinite, and $\frac{1}{p} = 0$; hence $\frac{1}{p'} = \frac{2}{r}$ or $p' = \frac{r}{2}$. That is, if the point from which the light comes is infinitely distant, and the incident rays are parallel to each other and to the principal axis, the reflected rays converge to a point halfway between the centre of the

mirror and the centre of curvature. This case is illustrated in fig. 497. The point of convergence F is called the *principal focus* of the mirror; its distance from the mirror is the *focal length*. Thus the focal length of a mirror is half its radius of curvature, or, if f denotes the focal length,

$$f = \frac{r}{2}.$$

If the point L returns towards the mirror, l , its image, moves from F to meet it. Since the angles of incidence and reflection are always equal, it follows that L and l arrive at C together, and object and image coincide. The formula also tells us that if $p = r$, p' must also = r . When the luminous point moves from C towards A, its image or conjugate focus moves away from C; and if the luminous point coincides with F, the reflected rays are parallel and the image is formed at an infinite distance away.

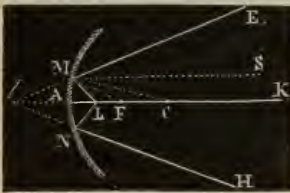

Fig. 499

Virtual image.—If the luminous point is between the principal focus and the mirror (fig. 499), we see—taking two incident rays LA and LM and proceeding as before—the reflected rays AL and ME do not meet, but are divergent. This is the case with all rays from the point L, and hence L has no real image; but if the reflected rays are conceived to be prolonged on the other side of the mirror, their prolongations will intersect in a

point l on the axis, and an eye looking in the direction KA experiences the same impression as if the rays were directly emitted from the point l . Hence a *virtual image* or *focus* is formed quite analogous to those formed by plane mirrors.

The formula $\frac{1}{p} + \frac{1}{p'} = \frac{2}{r} = \frac{1}{f}$ may be written $p' = \frac{pf}{p - f}$ from which we see that if p is greater than f , p' will be positive; that is, that if the luminous point is farther away from the mirror than the principal focus, there will be a real image formed on the same side of the mirror. If $p = f$, p' is infinite, and the reflected rays are parallel when the luminous point coincides with the principal focus; if p is less than f , that is, if L is between the mirror and its principal focus, p' is negative, and the image—a virtual image in this case—is formed on the other side of the mirror. It is convenient to consider all lines drawn in the direction from which the light is proceeding to be positive, and those drawn in the opposite direction to be negative. In figs. 498 and 499 the light which falls upon the mirror is coming from the right—hence all distances

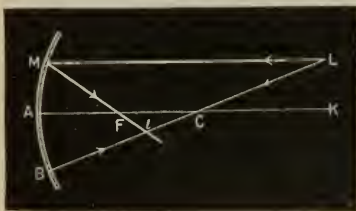

Fig. 500

measured to the right, as p , p' , r , f , are positive. If the mirror faces the left, distances measured to the left are positive. But no ambiguity will arise if we remember that the positive direction is that from which the light is coming.

Hitherto the luminous point has been supposed to be placed on the principal axis, but it is easy to find the position of its image when it is not so situated. In fig. 500, let ACK be the principal axis, L the luminous point, LCB a secondary axis through L. As before, it is only necessary to draw two incident rays from L and find where the corresponding reflected rays meet. If LCB be one of the incident rays, its corresponding reflected ray will be BCL; let LM, parallel to the principal axis, be the other. Since all rays parallel to the principal axis converge after reflection to the principal focus, LM will be reflected along MF. Hence *l*, where MF and BC meet, is the image of L. If L be not far removed from ACK, we may use the same formula as before to find the position of *l*, measuring *p* and *p'* along the principal axis.

536. **Reflection from convex mirrors.**—In convex mirrors only virtual images are formed. Let MM' (fig. 501) be a convex spherical mirror, with centre of curvature at C, and let L be a luminous point on the principal axis, CK. Of the rays diverging from L, consider one, LM, and draw the normal, CM. LM will be reflected along a line which makes the same angle with CM that the incident ray LM makes. The incident ray drawn towards C is reflected along its own path. The reflected rays do not meet, but their prolongations backwards meet at *l*, which is therefore the (virtual) image of L. F, halfway between C and the mirror, is the principal (virtual) focus of the mirror.



Fig. 501

The formula already proved for a concave mirror, viz.

$$\frac{1}{p} + \frac{1}{p'} = \frac{2}{r} = \frac{1}{f}$$

holds in this case also, if the sign of *r* or *f* is reversed, *p* and *p'* being, as before, the distances of L and *l* from the mirror.

Hence $\frac{1}{p} + \frac{1}{p'} = -\frac{1}{f}$ or $p' = -\frac{pf}{p+f}$ or *p'* is always negative since *p* is positive, and *f* is the numerical value of the focal length. Thus, wherever the luminous point may be, its image is always virtual. If L is infinitely distant so that the incident rays are parallel, the reflected rays diverge as if from the principal focus F.

537. **Formation of images of objects in concave mirrors.**—It has hitherto been supposed that the luminous or illuminated object placed in front of the mirror was simply a point; but if this object has a certain magnitude we can conceive a secondary axis drawn through each of its points, and thus a series of real or virtual point-images could be determined, the collection of which composes the image of the object. By the aid of the constructions which have already been employed, we shall investigate the position and magnitude of these images in concave and in convex mirrors.

Real image.—We shall first take the case in which the mirror is concave, and the object AB (fig. 502) is on the further side of the centre. To obtain the image of any point A, the simplest plan is to draw from A two rays: one,

ACE, along the secondary axis, which will be reflected along its own path ; the other, AM, parallel to the principal axis ; the latter will be reflected along MF through the principal focus, and will meet the other reflected ray at a ,

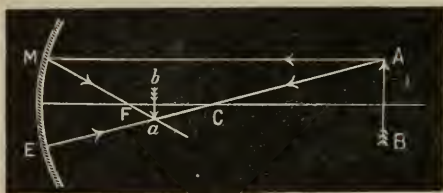

Fig. 502

which will therefore be the image of A. Making a similar construction for other points of AB, the complete image of the arrow will be seen to be formed at ab . *This image is real, inverted, smaller than the object, and placed between the centre of curvature and the principal focus.* This image

may be seen in two ways : by placing the eye in the continuation of the reflected rays, and then it is an aerial image which is seen ; or the rays may be intercepted by a screen, on which the image appears to be depicted.

If the luminous or illuminated object is placed at ab , between the principal focus and the centre, its image is formed at AB. It is then a real but inverted image ; it is larger than the object, and the larger as the object, ab , is nearer the focus.

If the object is placed in the principal focus itself, no image is produced ; for then the rays emitted from each point form, after reflection, as many pencils respectively parallel to the secondary axis, which is drawn through the point from which they are emitted (536), and hence no finite images are formed.

Virtual image.—The case remains in which the object is placed between the principal focus and the mirror. Let AB be this object (fig. 503). From



Fig. 503

A two rays are drawn, one through C striking the mirror at E, and reflected along its own path ; the other, AM, parallel to the principal axis, which is reflected through F. The reflected rays are divergent, but when produced backwards meet at a , which is therefore the virtual image of A. Similarly, an image of B is formed at b ; consequently an eye looking along

the principal axis sees at ab the image of AB. *This image is virtual, erect, and larger than the object.*

From what has been stated, it is seen that, according to the distance of the object, concave mirrors produce two kinds of images. A person, standing some distance in front of a concave mirror, sees an image of himself inverted and smaller—this is the real image ; as he approaches the centre of curvature the image comes to meet him. Object and image coincide at the centre of curvature ; the image is then confused, and disappears when he is at the focus ; still nearer the image appears erect, but larger—it is then a virtual image.

538. **Formation of images in convex mirrors.**—Let AB (fig. 504) be an object placed in front of a mirror at any given distance. AC and BC are secondary axes, and it follows, from what has been already stated, that all the rays from A are divergent after reflection, and that their prolongations pass through a point *a*, which is the virtual image of the point A. Similarly the rays from B form a virtual image of it in the point *b*. The construction is the same as before. The eye which receives the divergent rays sees in *ab* an image of AB. Hence, whatever the position of an object in front of a convex mirror, *the image is always virtual, erect, and smaller than the object.*

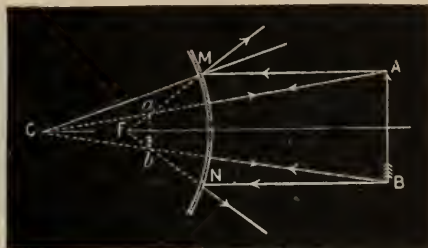

Fig. 504

539. **Determination of the focal length of a spherical mirror.**—Since the focal length of a concave mirror is half its radius of curvature, we may determine its value by measuring the curvature of the mirror by a spherometer (11). For this purpose the zero of the instrument is first determined, that is, its reading when the four feet are in the same plane. The spherometer is then placed on the mirror, and the middle leg screwed down until it comes in contact with the mirror. Let the distance through which it has been moved be *b*, and let the distance between the central leg and any one of the fixed legs be *r*. If *R* be the required radius of curvature, $R = \frac{r^2 + b^2}{2b}$, and *f*, the focal length, $= \frac{r^2 + b^2}{4b}$. This may be proved as follows:—

Let ADCD' (fig. 505) represent a great circle of the spherical mirror, supposed extended so as to form a complete sphere. The ends of the three fixed legs of the spherometer lie on the circumference of a small circle of the sphere. Let AC be the diameter of this circle, and let the central leg of the spherometer touch the surface at D. Then $DD' = 2R$, $BC = r$, $BD = b$, and by geometry $BC^2 = BD \cdot BD'$; that is, $r^2 = b(2R - b)$ or $R = \frac{r^2 + b^2}{2b}$. This method is equally applicable to the determination of the radius of curvature, and therefore of the focal length, of a *convex* spherical mirror.

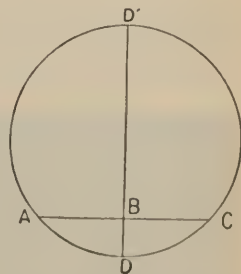

Fig. 505

A simple method of determining the focal length of a concave mirror when sunlight is available, is to support the mirror so that the incident rays of the sun are parallel to the principal axis; with a small screen of ground glass the point is sought at which the image of the sun is formed with the greatest distinctness; this is the principal focus, and its distance from the mirror the required focal length.

The focal length of a concave mirror may be determined in a dark room

by the method of conjugate foci. For this purpose we require only, besides the mirror, a luminous object and a screen. The former may be a candle or gas flame, or, better, black lines ruled on thin ground glass and illuminated

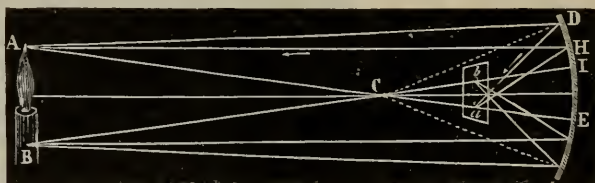

Fig. 506

by a gas flame. The screen is a small disc of ground glass. If in fig. 506 the mirror is arranged with its principal axis horizontal, and the candle is placed some distance away, as AB, but symmetrically with regard to the axis, its image will be formed at ab , and the screen must be moved until this position is found. If p and p' are the distances of candle and screen from the mirror, we have $\frac{1}{p} + \frac{1}{p'} = \frac{1}{f}$ whence f is known.



Fig. 507

front of a mirror, and if we look along the axis we see the real inverted image of the rod I. As O approaches the mirror, I is seen to meet it. They coincide at C, the centre of curvature, and the point of coincidence may be determined with considerable accuracy.

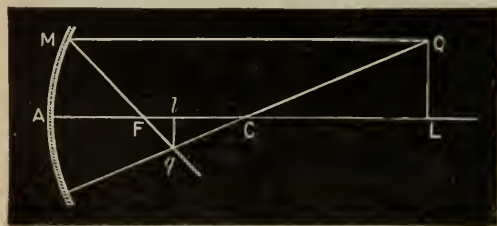

Fig. 508

540. Calculation of the magnitude of images.

By means of the formulæ already given (535) the magnitude of an image may be calculated when the distance of the object, its magnitude, and the radius of the mirror are given.

For if QL be the object (fig. 508), ql its image, $AL = p$, $Al = p'$, $AC = r$, by geometry

$$\frac{QL}{ql} = \frac{CL}{Cl} = \frac{p-r}{r-p'}$$

but since $\frac{1}{p} + \frac{1}{p'} = \frac{2}{r}$, $\frac{1}{p} - \frac{1}{r} = \frac{1}{r} - \frac{1}{p'}$, $\therefore \frac{p-r}{r-p'} = \frac{p}{p'}$.

Hence, if O and I represent the linear dimensions of object and image respectively,

$$\frac{I}{O} = \frac{r - \rho'}{\rho - r} = \frac{\rho'}{\rho}$$

Thus,

$$\begin{aligned} \frac{\text{size of the image (linear)}}{\text{size of the object}} &= \frac{\text{distance of the image from the centre of curvature}}{\text{distance of the object from the centre of curvature}} \\ \text{or} &= \frac{\text{distance of the image from the mirror}}{\text{distance of the object from the mirror}} \end{aligned}$$

The term *magnification*—that is, the ratio of the linear size of the image to that of the object—is used whether the image is greater or less than the object. *Zero magnification* means that the image is infinitely small as compared with the object; *unit magnification*, that the object and image are the same size. The relation given above holds whether the image be real or virtual, and for convex as well as concave mirrors.

541. Discussion of the formulæ for mirrors.—The formulæ in question

are
$$\frac{1}{\rho} + \frac{1}{\rho'} = \frac{2}{r} = \frac{1}{f} \quad \dots \dots \dots (1)$$

and
$$\frac{I}{O} = \frac{\rho'}{\rho} \quad \dots \dots \dots (2)$$

These hold for convex as well as concave mirrors, and for virtual as well as real images; but the convention with regard to signs must be attended to.

Equation (1) may be written
$$\rho' = \frac{\rho f}{\rho - f} = \frac{f}{1 - \frac{f}{\rho}} \quad \dots \dots \dots (3)$$

i. Concave mirror; f positive. If the object is at an infinite distance on the axis, $\rho = \infty$, the incident rays are parallel, and $\rho' = f$; that is, the reflected rays converge at the principal focus and (from equation 2) the image is infinitely small, in other words a mere point. As the object approaches the centre of curvature, so does the image. As $\rho' < \rho$, the image is smaller than the object. When $\rho = r = 2f$, $\rho' = 2f$; that is, object and image coincide at the centre, and the magnification = unity.

As the object approaches F , the image moves off to infinity and grows indefinitely in size. When the object is nearer the mirror than the principal focus, $\rho < f$ and (equation 3) ρ' is negative, and the image rapidly diminishes. If $\rho = f/2$, $\rho' = -f$, and the magnification = 2. When the luminous object is in contact with the mirror, so is the image.

ii. Convex mirror; f negative. Equation (3) becomes

$$\rho' = -\frac{\rho f}{\rho + f} = -\frac{f}{1 + \frac{f}{\rho}}$$

from which we see that, ρ being positive, ρ' is always negative, that is, the image is always virtual. When ρ is infinite, $\rho' = -f$, and the magnification is zero. As the object approaches the mirror the image increases in size, but cannot be greater than the object. Object and image coincide when $\rho = o$.

542. Spherical aberration. Caustics.—In the foregoing explanation of the formation of images by spherical mirrors, it has been assumed that

the aperture of the mirror does not exceed 8 or 10 degrees, since it is only when the incident rays are very close to the principal axis that the reflected rays meet in a single point. With a larger aperture the rays reflected near the edges meet the axis nearer the mirror than those that are reflected at a small distance from the centre of the mirror. Hence arises

a want of sharpness in these images, which is called *spherical aberration by reflection*, to distinguish it from the *spherical aberration by refraction*, which occurs in the case of lenses.



Fig. 509

Every reflected ray cuts the one next to it (fig. 509), and their points of intersection form in space

a curved surface which is called the *caustic by reflection*. The curve FM represents one of the branches of a section of this surface made by the plane of the paper. When the light of a candle is reflected from the inside of a teacup or a glass tumbler, a section of the caustic surface can be seen by partly filling the cup or tumbler with milk.

543. Applications of mirrors. Heliostat.—The applications of plane mirrors in domestic economy are well known. Mirrors are also frequently used in physical apparatus for sending light in a certain direction. We have already seen an application of this in the heliograph (533). The light of the sun can only be sent in a constant direction by making the mirror movable. It must have a motion which compensates for the continual change in the direction of the sun's rays produced by the apparent diurnal motion of the sun. This result is obtained by means of a clockwork motion, to which the mirror is fixed, and which causes it to follow the course of the sun. Such an apparatus is called a *heliostat*. The reflection of light is also used to measure the angles of crystals by means of the instruments known as *reflecting goniometers*.

Concave spherical mirrors are also often used. They are applied for magnifying *mirrors*, as in the older forms of shaving mirrors, and for burning mirrors. They also serve as reflectors, for conveying light to great distances, by placing a luminous object in their principal focus. The *search light* used by steamers in passing through the Suez Canal by night, and by war ships, consists of a powerful electric light placed at the principal focus of a concave spherical reflector. Parabolic reflectors, though theoretically preferable, have not hitherto been much used for this purpose on account of the difficulty of working the parabolic surface. They are, however, used in reflecting telescopes.

The images of objects seen in concave or convex mirrors appear smaller or larger, but otherwise similar geometrically, except in the case where some parts of a body are nearer the mirror than others. The distortion of features observed on looking into a spherical garden mirror is more marked the nearer we are to the glass. Objects seen in *cylindrical* or *conical* mirrors appear ludicrously distorted. From the laws of reflection the shape of such a distorted figure can be geometrically constructed. In like manner distorted pictures of objects can be constructed which,

seen in such mirrors, appear in their normal proportions. They are called *anamorphoses*.

544. **Parabolic mirrors.**—*Parabolic mirrors* are concave mirrors whose surface is generated by the revolution of the arc of a parabola, AM , about its axis AX (fig. 510).

It has been already stated that in spherical mirrors the rays parallel to the axis converge only approximately to the principal focus; and reciprocally, when a source of light is placed in the principal focus of these mirrors, the reflected rays are not exactly parallel to the axis. Parabolic mirrors are free from this defect; they are more difficult to construct, but are better for reflectors. It is a property of a parabola that the right line FM , drawn from the focus F to any point M of the curve and the line ML , parallel to the axis AF , make equal angles with the tangent TT' at this point. Hence all rays parallel to the axis after reflection meet in the focus of the mirror F ; and conversely, when a source of light is placed in the focus, the rays incident on the mirror are reflected exactly parallel to the axis. The light thus reflected tends to maintain its intensity even at a great distance, for it has been seen (519) that it is the divergence of the luminous rays which principally weakens the intensity of light.

From this property parabolic mirrors are used in carriage lamps, and in the lamps placed in front of and behind railway trains. These reflectors were formerly used for lighthouses, but have been replaced by lenticular glasses.

When two equal parabolic mirrors are cut by a plane perpendicular to the axis passing through the focus, and are then united at their intersections as shown in fig. 511, so that their foci coincide, a system of reflectors is obtained with which a single lamp illuminates in two directions at once. This arrangement is used in lighting staircases and passages.

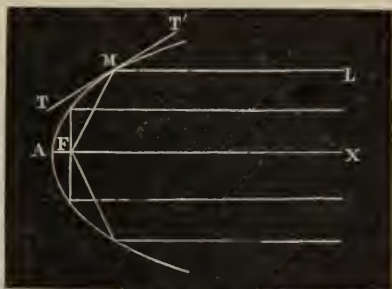

Fig. 510



Fig. 511

CHAPTER III

SINGLE REFRACTION. LENSES

545. **Phenomenon of refraction.**—*Refraction* is the deflection or bending which the rays of light experience in passing *obliquely* from one medium to another : for instance, from air into water (fig. 513). If the incident ray is perpendicular to the surface separating the two media, it is not bent, but continues its course in a right line (fig. 512).

Fig. 512

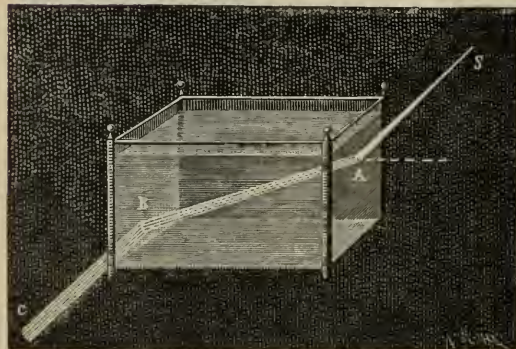
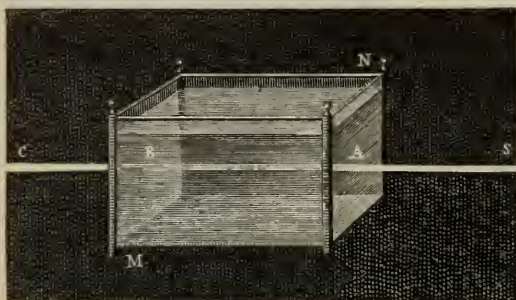

Fig. 513

perpendicular to the surface separating the two media, it is not bent, but continues its course in a right line (fig. 512).

The *incident ray* being represented by SO (fig. 514), the *refracted ray* is the direction OH which light takes in the second medium ; and of the angles SOA and HOB, which these rays form with the normal AB, to the surface which separates the two media, the first is the *angle of incidence*, and



Fig. 514

the other the *angle of refraction*. According as the refracted ray approaches or deviates from the normal, the second medium is said to be more or less *refracting* or *refracting* than the first.

All the light which falls on the surface of a refracting substance does not completely pass into it ; one part is reflected, regularly or diffusely (528), while another penetrates into the medium.

In uncrystallised media, such as air, liquids, ordinary glass, the luminous ray is singly refracted; but in certain crystallised bodies, such as Iceland spar, selenite, &c., the incident ray gives rise to two refracted rays. The latter phenomenon is called *double refraction*, and will be discussed in another part of the book. We shall here deal exclusively with *single refraction*.

546. **Laws of single refraction.**—When a luminous ray is refracted in passing from one medium into another of a different refractive power, the following laws prevail:—

I. *Whatever the obliquity of the incident ray, the ratio which the sine of the incident angle bears to the sine of the angle of refraction is constant for the same two media, and the same coloured light, but varies with different media.*

II. *The incident and the refracted rays are in the same plane, which is perpendicular to the surface separating the two media.*

These have been known as *Descartes's laws*; they are, however, really due to Willibrod Snell, who discovered them in 1620; they are demonstrated by the same apparatus as that used for the laws of reflection (522). The plane mirror in the centre of the graduated circle is replaced by a semi-cylindrical glass vessel, filled with water to such a height that its level is exactly the height of the centre (fig. 515). If the mirror, M, is then so inclined that a reflected ray, MO, is directed towards the centre, it is refracted on passing into the water, but it passes out without refraction, because its direction is then at right angles to the curved sides of the vessel. In order to observe the course of the refracted ray, it is received on a screen, P, which is moved until the image of the aperture in the screen N is formed at its centre. In all positions of the screens N and P, the sines of the angles of incidence and refraction are measured by means of two graduated rules, movable so as to be always horizontal, and hence perpendicular to the diameter AD.

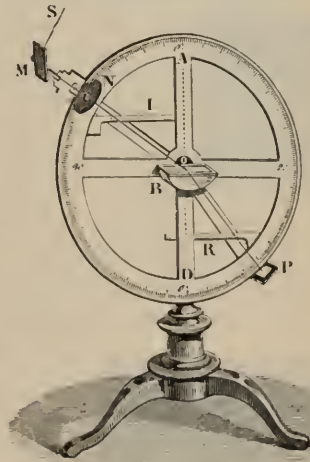

Fig. 515

On reading off the lengths which are proportional to the sines of the angles MOA and DOP in the scales I and R, the numbers are found to vary with the position of the screens, but their ratio is constant; that is, if the sine of incidence becomes twice or three times as large, the sine of refraction increases in the same ratio, which demonstrates the first law. The second law follows from the arrangement of the apparatus, for the plane of the graduated limb is perpendicular to the surface of the liquid in the semi-cylindrical vessel.

547. **Index of refraction.**—The ratio between the sines of the incident and refracted angles is called *index of refraction*, or *refractive index* of the

second medium with respect to the first. Thus if n is the refractive index, and i and r the angles of incidence and refraction, $\sin i = n \sin r$. The refractive index varies with the media; for example, from air to water it is $\frac{4}{3}$, and from air to glass it is $\frac{3}{2}$. When the refraction of a substance is given without qualification, it is understood that the light is passing from air (or more strictly from empty space) into that substance.

If the media are considered in an inverse order—that is, if light passes from water to air, or from glass to air—it follows the same course, but in a contrary direction, PO becoming the incident and OM the refracted ray. Consequently the index of refraction is reversed; from water to air it is then $\frac{3}{4}$, and from glass to air $\frac{2}{3}$.

On the undulatory theory of light, the index of refraction of one medium with regard to another is the ratio of the velocity with which light travels in the second medium to that with which it travels in the first. Thus the velocity of light in glass is two-thirds and in water three-fourths of its velocity in air, or, approximately, in empty space.

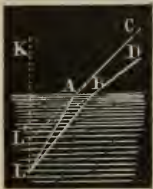

Fig. 516

548. **Effects produced by refraction.**—In consequence of refraction, bodies immersed in a medium more highly refracting than air appear nearer the surface of this medium, but they appear to be more distant if immersed in a less refracting medium. Let L (fig. 516) be an object immersed in a mass of water. In passing thence into air, the rays LA, LB . . . diverge from the normal to the point of incidence, and take the direction AC, BD . . . , the prolongations of which intersect approximately in the point L', placed on the perpendicular L'K. Supposing the points A, B . . . are not far removed from the normal KL, an eye looking vertically downwards and receiving these rays sees the image of L at L'. If the eye looks obliquely at the object, the image rises, and the greater the obliquity of the rays LA, LB . . . , the higher the object appears. For the same reason a stick placed obliquely in water seems bent, the immersed part appearing raised.



Fig. 517

It is easy to show that the apparent distance of the point L below the surface is less than the true distance in the ratio $1/n$, where n is the refractive index of water. For if NN' (fig. 517) is the normal to the surface at A, the angle LAN' is the angle of incidence, and NAc the angle of refraction of the incident ray

$$LA, \text{ and } \frac{\sin NAc}{\sin LAN'} = n.$$

But $\frac{\sin NAc}{\sin LAN'} = \frac{\cos L'AO}{\cos LAO} = \frac{OA}{AL'} \cdot \frac{AL}{OA} = \frac{AL}{AL'} = \frac{OL}{OL'}$, if A is sufficiently near to O.

Hence, if p and p' are the respective distances of a point and its image from the surface of water, $p = np'$. Thus a stream or pond that appears to the eye looking vertically down to be 3 feet deep is in reality 4 feet deep.

If the eye looks obliquely at the object the image rises, and is slightly

nearer to the observer. Thus, when a stick is placed obliquely and partly immersed in water, not only does the stick appear to be broken at the surface, but the part immersed appears to be bent.

An experimental illustration of the effect of refraction is the following :— A coin is placed in an empty porcelain basin, and the eye placed so that the coin is just not visible. If now, the position of the eye remaining unaltered, water is poured into the basin, the coin becomes visible. A consideration of fig. 516 will suggest the explanation of this phenomenon.

Owing to an effect of refraction, stars are visible to us even when they are below the horizon. For as the layers of the atmosphere are denser in proportion as they are nearer the earth, and as the refractive power of a gas increases with its density (561), it follows that on entering the atmosphere the luminous rays become bent, as seen in fig. 518, describing a curve before reaching the eye, so that we can see the star at S' along the tangent of this curve instead of at S . In our climate the atmospheric refraction does not raise the stars when on the horizon more than half a degree.

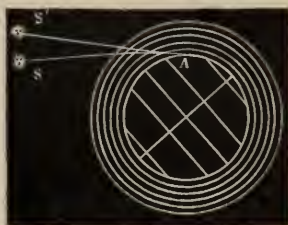

Fig. 518

The effect of refraction is that objects at a distance appear higher than they are in reality ; our horizon is thereby widened. When individual layers of air refract more strongly than usual, objects may thereby become visible which are usually below the horizon. Thus, from Hastings, the coast of France, which is at a distance of 56 miles, is not unfrequently seen.

549. **Multiple images formed by glass mirrors.**—Metal mirrors which have but one reflecting surface give only one image ; glass mirrors give rise to several images, which are readily observed when the image of a candle is looked at obliquely in a looking-glass. A very feeble image is first seen, and then a very distinct one ; behind this there are several others, whose intensities gradually decrease until they disappear.

This phenomenon arises from the looking-glass having two reflecting surfaces. When the rays from the point A meet the surface, fig. 519, a part is reflected and forms an image, a , of the point A , on the prolongation of the ray bE , reflected by this surface ; the other part passes into the glass and is reflected at c from the layer of metal which covers the back surface of the glass, and reaching the eye in the direction dH , gives the image a' . This image is distant from the first by double the thickness of the glass. It is brighter, because metal reflects better than glass.



Fig. 519

In regard to other images it will be remarked that whenever light is transmitted from one medium to another—for instance, from glass to air (547)—only some of the rays get through ; the remainder are reflected at the surface

which bounds the two media. Consequently when the pencil cd , reflected from c , attempts to leave the glass at d , most of the rays composing it pass into the air, but some are reflected at d , and continue within the glass. These are again reflected by the metallic surface, and form a third image of A ; after this reflection they come to MN , when many emerge and render the third image visible; but some are again reflected within the glass, and in a similar manner give rise to a fourth, fifth, &c., image, thereby completing the series above described. It is manifest from the above explanation that each image must be much feebler than the one preceding it, and consequently only a small number are visible—ordinarily not more than eight or ten in all.

This multiplicity of images is objectionable in observations, and, accordingly, metal mirrors, or right-angled prisms (556), are to be preferred in optical instruments.

550. Total reflection. Critical angle.—When a ray of light passes from one medium into another which is less refracting, as from water into air, it has been seen that the angle of incidence is less than the angle of refraction. Hence, when light is propagated in a mass of water from S to O (fig. 520), there is always a value of the angle of incidence SOB , such that the angle of refraction AOR is a right angle, in which case the refracted ray emerges parallel to the surface of the water.

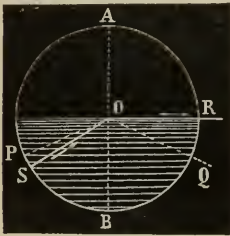

Fig. 520

This angle, SOB , is called the *critical angle*, since for any greater angle, POB , the incident ray cannot emerge, but undergoes an internal reflection, which is called *total reflection* because the incident light is entirely reflected. From the formula $\sin i = n \sin r$ we see that if $i = 90^\circ$ $\sin i = 1$, and if r_c is the corresponding value of r ,

i.e. the critical angle, $\sin r_c = \frac{1}{n}$. From water to air the critical angle is $48^\circ 53'$; from glass to air, $41^\circ 48'$.

The occurrence of this internal reflection may be observed by the following experiment:—An object, A , is



Fig. 521

placed before a rectangular glass vessel filled with water (fig. 521); the surface of the liquid is then looked at as shown in the figure, and an image of the object A is seen at a , formed by the rays reflected at m , in the ordinary manner of a mirror.

In total reflection there is no loss of light from absorption or transmission, and accordingly it produces the greatest brilliancy. If an empty test-tube be

placed in a slanting position in water, its surface, when looked at from above, shines as brilliantly as pure mercury; those rays which fall obliquely on the side at an angle greater than the critical angle cannot pass into the air inside the tube, and are, therefore, totally reflected upwards. If a little water

is passed into the tube, that portion of it loses its lustre. Bubbles, again, in water glisten like pearls, and cracks in transparent bodies like strips of silver, for the oblique rays are totally reflected. The lustre of transparent bodies bounded by plane surfaces, such as the lustre of chandeliers, arises mainly from total internal reflection. This lustre is the more frequent and the more brilliant the smaller the critical angle, that is, the greater the refractive index; the lustre of diamond, therefore, is the most brilliant.

The erecting prism used with projection apparatus (616) is an interesting application of the principle of total internal reflection; also the camera lucida (615), and the prismatic compass (732).

551. **Mirage.**—The *mirage* is an optical illusion by which inverted images of distant objects are seen as if below the ground or in the atmosphere. This phenomenon is of most frequent occurrence in hot climates, and more especially on the sandy plains of Egypt. The ground there has often the aspect of a tranquil lake, on which are reflected trees and the surrounding villages. Monge, who accompanied Napoleon's expedition to Egypt, was the first to give an explanation of the phenomenon.

It is due to refraction, which results from the unequal density of the different layers of the air when they are expanded by contact with the heated



Fig. 522

soil. The least dense layers are then the lowest, and the pencil of light from an elevated object, A (fig. 522), traverses layers which are gradually less refracting; for, as will be shown presently (561), the refracting power of a gas diminishes with lessened density. The angle of incidence accordingly increases from one layer to the next, and ultimately reaches the critical angle, beyond which internal reflection succeeds to refraction (550). The pencil then rises, as seen in the figure, and undergoes a series of successive refractions, but in the direction contrary to the first, for it now passes through layers which are gradually more refracting. The pencil then reaches the eye with the same direction as if it had proceeded from a point below the ground, and hence it gives an inverted image of the object, just as if it had been reflected from the surface of a tranquil lake.

The effect of the mirage may be illustrated artificially, though feebly, as

But angle = $\frac{\text{arc}}{\text{radius}}$, when the angle is formed at the centre of a circle; and if B is very near to A, we may assume BQ = AQ and BP = AP, therefore

$$n \left(\frac{\text{arc AB}}{\rho} - \frac{\text{arc AB}}{r} \right) = \left(\frac{\text{arc AB}}{\rho'} - \frac{\text{arc AB}}{r} \right)$$

or
$$n \left(\frac{1}{\rho} - \frac{1}{r} \right) = \frac{1}{\rho'} - \frac{1}{r}; \therefore \frac{n}{\rho} - \frac{1}{r} = \frac{n-1}{r}$$

Example.—Let $r = 6$ inches, $\rho = 4$ inches, $n = \frac{3}{2}$,

$$\frac{1}{\rho'} = \frac{n}{\rho} - \frac{n-1}{r} = \frac{3}{8} - \frac{1}{12} = \frac{7}{24}; \therefore \rho' = \frac{24}{7} = 3\frac{3}{7}.$$

If the surface instead of being spherical had been plane, ρ' would have been = 3. This follows from the formula on putting $r = \infty$.

In the case here considered, AP and AC are both measured in the positive direction, and the light passes from a more dense to a less dense medium. But the formula holds in all cases. We shall have to use it again in considering the images formed by lenses.

TRANSMISSION OF LIGHT THROUGH TRANSPARENT MEDIA

553. **Media with parallel faces.**—Any transparent medium bounded by two parallel plane surfaces is called a *plate*. When light traverses a plate of any substance, the *emergent rays* are parallel to the incident rays.

Let SA be a ray incident on one face of a glass plate (fig. 525), and DB the emergent ray, i and r the angles of incidence and of refraction at the entrance of the ray, and, lastly, i' and r' the corresponding angles at its emergence. At A the light undergoes a first refraction, and $n = \frac{\sin i}{\sin r}$ (549). At D it is refracted



Fig. 525

a second time, and the index is then $\frac{\sin i'}{\sin r'}$. But we have seen that the index of refraction of glass with respect to air is the reciprocal of the index of air with respect to glass; hence

$$\frac{\sin i'}{\sin r'} = \frac{\sin r}{\sin i}.$$

But as the two normals at A and D are parallel, the angles r and i' are equal, as being alternate interior angles. As the numerators in the above equation are equal, the denominators must also be equal; the angles r' and i are therefore equal, and hence DB is parallel to SA.

554. **Prism.**—In optics a *prism* is any transparent medium comprised between two plane faces inclined to each other. The intersection of these

two faces is the *edge* of the prism, and their inclination is its refracting angle. Every section perpendicular to the edge is called a *principal section*.

The prisms used for experiments are generally right triangular prisms of glass, as shown in fig. 526, and their principal section is a triangle (fig. 527). In this section the point A is called the *summit* of the prism, and the right line BC is called the *base*: these expressions have reference to the triangle ABC, and not to the prism.



Fig. 526

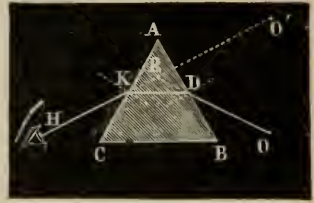

Fig. 527

555. **Path of rays in prism. Angle of deviation.**—When the laws of refraction are known, the path of the rays in a prism is readily determined. Let O be a luminous point (fig. 527) in the same plane as the principal section ABC of a prism, and let OD be an incident ray, let us suppose, of monochromatic light. This ray is refracted at D, and approaches the normal, because it passes into a more highly refracting medium. At K it experiences a second refraction, but it then deviates from the normal,



Fig. 528

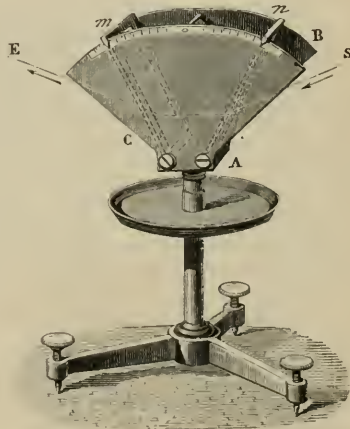

Fig. 529

for it passes into air, which is less refractive than glass. The light is thus refracted twice in the same direction, so that *the ray is deflected towards the base*, and consequently the eye which receives the emergent ray KH sees the virtual image of O, which is formed at O'; that is, *objects seen through a prism appear deflected towards its summit*. The angle OEO', which the incident and emergent rays form with each other, expresses the deviation of light caused by the prism, and is called *the angle of deviation*.

In ordinary light, objects seen through a prism appear bordered with colour : this phenomenon, known as *dispersion*, will be afterwards described (574).

The angle of deviation increases with the refractive index of the material of the prism, and also with its refracting angle. It also varies with the angle under which the luminous ray enters the prism.

That the angle of deviation increases with the refractive index may be shown by means of the *polyprism*. This name is given to a prism formed of several prisms of the same angle connected at their ends (fig. 528). These prisms are made of unequally refracting substances, such as flint glass, rock crystal, or crown glass. If any object—a horizontal line, for instance—is looked at through the polyprism, its different parts are seen at unequal heights. The highest portion is that seen through the flint glass, the refractive index of which is greatest ; then the rock crystal ; and so on in the order of the decreasing refractive indices.

The *prism with variable angle* (fig. 529) is used for showing that the angle of deviation increases with the refracting angle of the prism. It consists of two parallel brass plates, B and C, fixed on a support. Between these are two glass plates, moving on a hinge with some friction against the plates so as to close it. When water is poured into the vessel the angle may be varied at will. If a ray of light, S, be allowed to fall upon one of them, by inclining the other more the angle of the prism increases, and the deviation of the ray is seen to increase.

556. **Use of right-angled prisms as reflectors.**—Prisms whose principal section is an isosceles right-angled triangle afford an important application of total reflection (550). For let ABC (fig. 530) be the principal section of such a prism, O a luminous point, and OH a ray at right angles to the face BC. This ray enters the glass without being refracted, and makes with the face AB an angle equal to B—that is, to 45° —and therefore greater than the critical angle of glass, which is $41^\circ 48'$ (550).



Fig. 530

The ray OH undergoes, therefore, at H total reflection, which imparts to it a direction HI perpendicular to the second face AC. Thus the hypotenuse surface of this prism produces the effect of the most perfect plane mirror, and an eye placed at I sees O', the image of the point O. This property of right-angled prisms is frequently used in optical instruments, such as the camera lucida (615), the Newtonian telescope (611), and the prismatic compass (732), instead of metal reflectors which readily tarnish. They are also largely used with the limelight or electric-light lantern for projection in order to erect images that would otherwise be inverted (616). The newer *lighthouse lenses* are partly made up of such prisms.

557. **Conditions of emergence in prisms.**—In order that any monochromatic ray refracted at the first face of a prism may emerge from the second, it is necessary that the refracting angle of the prism be less than twice the critical angle of the substance of which the prism is composed. For if LI (fig. 531) is the ray incident on the first face, IE the refracted ray, PI and PE the normals, the ray IE can only emerge from the second face

when the angle IEP is less than the critical angle (550). But as the incident angle LIN increases, the angle EIP also increases, while IEP diminishes. Hence, according as the direction of the ray LI tends to become parallel with the face AB, does this ray tend to emerge at the second face.

Let LI be now parallel to AB, the angle r is then equal to the critical angle l of the prism, because it has its maximum value. Further, the angle EPK, the exterior angle of the triangle IPE, is equal to $r + i'$; but the angles EPK and A are equal, because the sides which contain them are at right angles to each other, and therefore $A = r + i'$; therefore also $A = l + i'$, for in this case $r = l$. Hence, if $A = 2l$ or is $> 2l$, we shall have $i' = l$ or $> l$, and therefore the ray would not emerge at the second face, but would be parallel to AC or would undergo internal reflection, and emerge at a third face, BC. This would be much

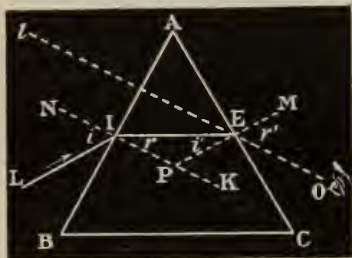

Fig. 531

more the case with rays whose incident angle is less than BIN, because we have already seen that i' would continually increase. Thus in the case in which the refracting angle of a prism is equal to $2l$ or is greater, no luminous ray could pass through the faces of the refracting angle.

As the critical angle of glass is $41^\circ 48'$, and twice this angle is less than 90° , objects cannot be seen through a glass prism whose refracting angle is a right angle. As the critical angle of water is $48^\circ 35'$, light could pass through a hollow right-angled prism formed of three glass plates and filled with water.

If we suppose A to be greater than l and less than $2l$, then of rays incident at I, some within the angle NIB will emerge from AC, others will not emerge, nor will any emerge that are incident within the angle NIA. If we suppose A to have any magnitude less than l , all rays incident at I within the angle NIB will emerge from AC, as also will some of those incident within the angle NIA.

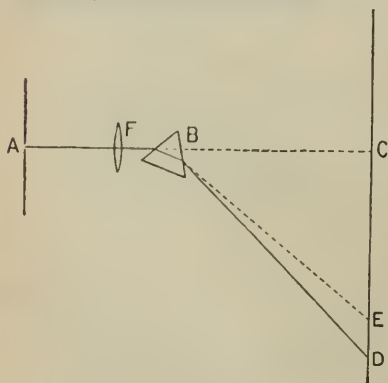

Fig. 532

558. **Minimum deviation.**—When a pencil of monochromatic light passes through an aperture A, in the side of a dark chamber (fig. 532), the pencil may be focused by a lens, F, on a different screen at C. But if a vertical prism be interposed between the lens and the screen, the pencil is deviated towards the base of the

prism, and the image is projected at D, at some distance from the point C. If the prism is turned so that the incident angle decreases, the image on

the screen approaches the point C up to a certain position, E, from which it reverts to its original position even when the prism is rotated in the same direction. Hence there is a deviation, EBC, less than any other. It may be proved mathematically that this *minimum deviation* takes place when the angles of incidence and of emergence at the faces of the prism are equal.

The angle of minimum deviation may be calculated when the incident angle and the refracting angle of the prism are known. For when the deviation is a minimum, then since the angle of emergence r' is equal to the incident angle i (fig. 531), r must equal i' . But it has been shown above (557) that $A = r + i'$; consequently

$$A = 2r \quad \dots \quad (1)$$

If the minimum angle of deviation LDl be called d , this angle being exterior to the triangle DIE, we readily obtain the equation

$$d = i - r + r' - i' = 2i - 2r,$$

whence
$$d = 2i - A \quad \dots \quad (2)$$

which gives the angle d , when i and A are known.

From the formulae (1) and (2) a third may be obtained, which connects the index of refraction of a prism with its refracting angle and the minimum deviation. The index of refraction, n , is the ratio of the sines of the angles of incidence and refraction; hence $n = \frac{\sin i}{\sin r}$; replacing i and r from their values in the above equations (1) and (2) we get

$$n = \frac{\sin\left(\frac{A+d}{2}\right)}{\sin \frac{A}{2}} \quad \dots \quad (3)$$

559. **Measurement of the refractive index of solids. Spectrometer.**—By means of the preceding formula (3) the refractive index of a solid may be calculated when the angles A and d are known, and these may be determined by means of the spectrometer.

The spectrometer is in appearance similar to the spectroscopie illustrated in fig. 567. Supported on a vertical upright is a horizontal graduated disc, T (fig. 533), and at its centre a smaller circular table, D, which can be turned about a central vertical axis and clamped in any desired position. A is a collimator with vertical slit at the end a and convex lens at b , the slit being at the principal focus of the lens (563). B is a telescope which can be moved round the circle in such a way

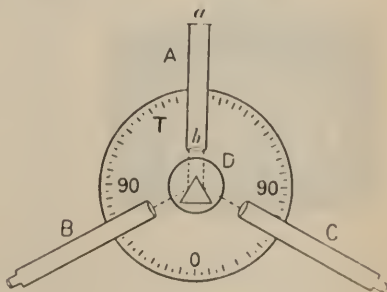

Fig. 533

that its axis is always directed towards the centre of the circle; it can be clamped anywhere on the circle, and its position read off by a vernier (not shown) moving over the graduations of the scale. The prism whose refracting angle is to be measured is placed on the central table with its edge near the centre in such a way that, when the slit a is illuminated by monochromatic, *e.g.* sodium, light, the parallel rays which emerge from b fall partly on one and partly on the other face of the prism. The telescope—which has previously been focused for parallel rays—is moved to the position B, so that an observer may see through it an image of the slit a by the rays reflected from the left-hand side of the prism. The telescope is then moved to C, and an image of the slit is again seen, this time by the rays reflected from the right-hand face.

It is not difficult to prove that the angle BC through which the telescope has been turned

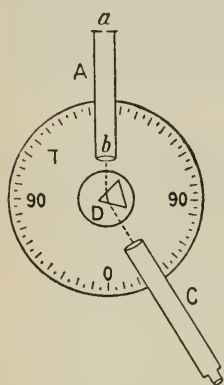

Fig. 534

is twice the angle of the prism. Thus the angle A is determined. To find the minimum deviation d , the prism is placed as shown in fig. 534, and the telescope adjusted at C so that the image of the slit seen by refraction coincides with the cross-wires of the telescope. The angle between C and the zero graduation is the deviation. The observer, in order to make this a minimum, turns the small table one way or the other, each time adjusting the telescope, until C is brought as near to the zero as possible. Thus the minimum deviation is found. It is usual, having measured d on one side, to turn the table D round and reverse the position of the prism, the telescope C being now on the left-hand side of the zero. The minimum deviation is again found, and the mean of the two values taken. The values of A and d , substituted in the equation (3) (558), give the value of n .

560. **Measurement of the refractive index of liquids.**—Biot applied Newton's method to determining the refractive index of liquids. For this purpose a cylindrical cavity, O, of about 0.75 inch in diameter, is perforated in a glass prism, PQ (fig. 535), from the incident face to the face of emergence.

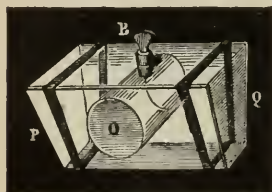

Fig. 535

This cavity is closed by two plates of thin glass which are cemented on the sides of this prism. Liquids are introduced through a small stoppered aperture, B. The refracting angle and the minimum deviation of the liquid prism in the cavity O having been determined, their values are introduced into the formula (3) of art. 558, which gives the index.

561. **Measurement of the refractive index of gases.**—A method for this purpose, founded on that of Newton, was devised by Biot and Arago. The apparatus which they used consists of a glass tube (fig. 536), bevelled at

its two ends, and closed by glass plates, which are at an angle of 143° . This tube is connected with a bell-jar, H, in which there is a siphon barometer, and with a stopcock by means of which the apparatus can be exhausted, and different gases introduced. When the tube, AB, has been exhausted, a ray of light, SA, is transmitted through it, which is bent away from the normal through an angle $r-i$ at the first incidence, and towards the normal through an angle $i'-r'$ at the second. These two deviations being added, the total deviation, d , is $r-i+i'-r'$. In the case of a minimum deviation, $i=r'$ and $r=i'$, whence $d=A-2i$, since $r+i'=A$ (557). The index from vacuum to air, which is evidently $\frac{\sin r}{\sin i}$, has therefore the value

$$\frac{\sin \frac{A}{2}}{\sin \left(\frac{A-d}{2} \right)} \dots \dots \dots (4)$$

Hence, in order to deduce the refractive index n from vacuum into air, which is the *absolute index* of air, it is merely necessary to know the refracting angle, A , and the angle of minimum deviation, d . To obtain the absolute index of any other gas, we first produce a vacuum, and then introduce the gas; the angles A and d having been measured, the above formula gives the index of refraction from the gas to air. Dividing the index of refraction from vacuum to air by the index of refraction from the gas to air we obtain the index of refraction from vacuum to the gas; that is, its absolute index.

It appears probable that certain relations exist between the refractive index, n , and the density, d , of a body. These relations are of considerable importance in questions of theoretical chemistry regarding the constitution of bodies. They are expressed by the

formula $R = \frac{n^2 - 1}{n^2 + 2} \cdot \frac{1}{d}$, which is known as the *constant of refraction*. If this is multiplied by a , the atomic weight, we

have the *atomic refraction* $\frac{n^2 - 1}{n^2 + 2} \cdot \frac{a}{d}$; or, if by the molecular weight, m ,

we have the *molecular refraction* $\frac{n^2 - 1}{n^2 + 2} \cdot \frac{m}{d}$. The expression $\frac{n^2 - 1}{n^2 + 2} \cdot \frac{1}{d}$ is for a given substance independent of its condition whether liquid or gaseous. Hence, if we know the densities of a substance in the two states, and its refraction index in one state, we can calculate it in the other.

The following table gives the refractive indices for the three principal Fraunhofer lines (585), the red, yellow, and violet; the last column gives the dispersion (577), or the difference between the extreme red, n_A , and the extreme violet, n_V , rays.

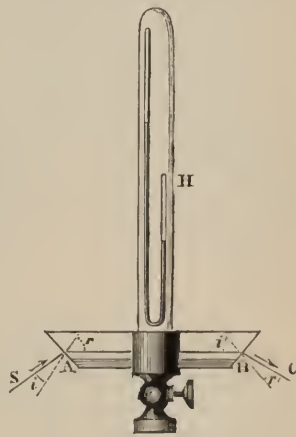

Fig. 536

	A	D	H	$n_H - n_A$
Water	1'329	1'331	1'344	0'015
Alcohol	1'360	1'364	1'375	0'015
Crown glass (light)	1'510	1'575	1'531	0'021
" " (heavy)	1'610	1'612	1'631	0'021
Rock salt	1'538	1'545	1'569	0'031
Flint glass (light)	1'599	1'609	1'640	0'041
" " (heavy)	1'735	1'751	1'811	0'076
Calcspars (ordinary)	1'650	1'659	1'683	0'033
" " (extraordinary)	1'483	1'483	1'498	0'015
Carbon bisulphide	1'612	1'631	1'703	0'091

The following are the mean values for a few other substances, and correspond nearly to the E line :—

Ice	1'310	Rock crystal	1'545
Solution of nitre	1'355	Benzole	1'586
Turpentine	1'363	Oil of cassia	1'621
Diamond			2'750

For the refractive indices of different parts of the eye, see art. 626.

Mean refractive indices of gases

Vacuum	1'000000	Carbonic acid	1'000446
Hydrogen	1'000138	Hydrochloric acid	1'000449
Oxygen	1'000272	Nitrous oxide	1'000503
Air	1'000294	Sulphurous acid	1'000665
Nitrogen	1'000300	Ethylene	1'000678
Ammonia	1'000385	Chlorine	1'000772

LENSES. THEIR EFFECTS

562. **Different kinds of lenses.**—*Lenses* are transparent media which, from the curvature of their surfaces, have the property of causing the luminous rays which traverse them either to converge or to diverge. According to their curvature they are either *spherical*, *cylindrical*, *elliptical*, or *parabolic*. Those used in optics are exclusively spherical. They are commonly made either of *crown glass*, which is free from lead, or of *flint glass*, which contains lead, and is more refractive than crown glass.

The combination of spherical surfaces, either with each other or with plane surfaces, gives rise to six kinds of lenses, sections of which are represented in fig. 537; four are formed by two spherical surfaces and two by a plane and a spherical surface.

M is a *double convex*, N is a *plano-convex*, O is a *converging concavo-convex*, P is a *double concave*, Q is a *plano-concave*, and R is a *diverging concavo-concave*. The lenses O and R are also called *meniscus* lenses, from their resemblance to the crescent-shaped moon; O is also called a *periscope* lens.

The first three, which are thicker at the centre than at the borders, are

converging or convex lenses; the others, which are thinner in the centre, are diverging or concave. In the first group the double convex lens only need be considered, and in the second the double concave, as the properties of each of these lenses apply to all those of the same group.

In lenses whose two surfaces are spherical, the centres of the two spheres are called *centres of curvature*, and the right line which passes through

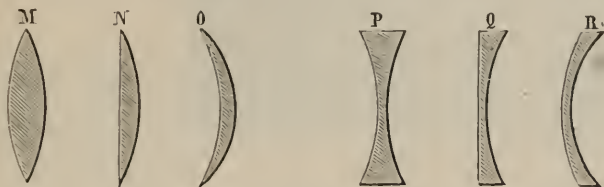

Fig. 537

these two centres is the *principal axis* of the lens. In a plano-concave or plano-convex lens the principal axis is the perpendicular let fall from the centre of curvature of the spherical face on the plane face.

Suppose a luminous point to be situated on the principal axis of a convex or concave lens. Rays from the point fall upon the lens, and, after refraction at the first and second surfaces, converge to or diverge from a point, which is the image of the luminous point. We proceed, before describing the phenomena of lenses, to obtain a formula which shall give the relation between the distances of object and image from the lens, and be applicable both to convex and to concave lenses.

563. **Formulae for lenses.**—Let MAB be a lens (fig. 538). A convex lens of this shape is chosen because each of its faces has a positive curvature, that

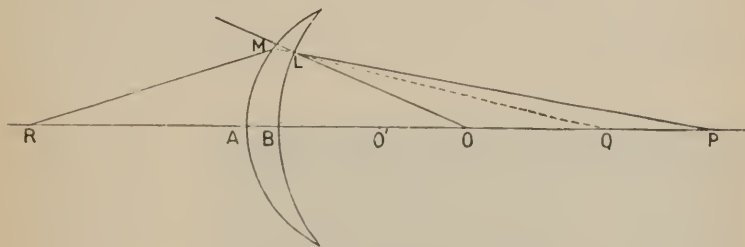

Fig. 538

is, the radii of curvature of both faces are drawn in the direction from which the light is coming. Let O be the centre of curvature of the first face, LB, O' of the second, MA, and let $OB = r$, $O'A = s$. P is a luminous point on the principal axis, and an incident ray, PL, is bent at the point of incidence towards the normal along LM. Another incident ray, PB, enters the glass without refraction. The two rays BA and LM are divergent, but if produced backwards, meet at a point Q, which is therefore the virtual image of P by refraction at the first surface of the lens.

Let $BP = p$, $BQ = q$, and let n = the refractive index of the glass. We may

apply the formula of art. 552 to this case, remembering however that here the rays are passing from air into glass, whereas in 552 they were passing from glass into air; hence instead of n we must use $1/n$. The formula then becomes

$$\frac{1}{n} - \frac{1}{q} = \frac{1}{n} - \frac{1}{r}, \text{ or } \frac{1}{p} - \frac{n}{q} = \frac{1-n}{r} \quad \dots \quad (1)$$

The point Q may now be treated as if it were a real source of light *in a medium of glass*, emitting rays which fall upon the second surface, AM, of the lens, and after refraction into air converge to a point R on the axis. In the elementary theory of lenses it is assumed that the lenses are very thin, so that the distance of a point from the lens is the same from whichever side of the lens it is measured. On this assumption BQ = AQ = q , and let AR = p . Then, applying the same formula of art. 552, and remembering that the rays are now passing from glass into air, we have

$$\frac{n}{q} - \frac{1}{p'} = \frac{n-1}{s}, \text{ since } AO' = s \quad \dots \quad (2)$$

Combining the two formulæ and eliminating $\frac{n}{q}$, we have

$$\frac{1}{p'} - \frac{1}{p} = (n-1) \left(\frac{1}{r} - \frac{1}{s} \right) \quad \dots \quad (3)$$

This is a general formula, applicable to all cases both of convex and concave lenses, provided it be borne in mind that all distances measured from the lens to the right (supposing the incident light to come from the right) are positive and to the left negative.

If the lens is convex, and the incident beam parallel to the principal axis, the refracted rays converge to a point on the negative side of the lens, called the *principal focus*. Its distance from the lens is called the *focal length* of the lens. The value of the focal length, f , is given by the formula, on putting $p = \infty$, or $1/p = 0$; then $\frac{1}{p'} = \frac{1}{f} = (n-1) \left(\frac{1}{r} - \frac{1}{s} \right)$.

Thus the focal length of a lens depends on the curvature of the two faces and on the refractive index of the material of the lens.

Replacing $(n-1) \left(\frac{1}{r} - \frac{1}{s} \right)$ by $\frac{1}{f}$ in formula (3), we have

$$\frac{1}{p'} - \frac{1}{p} = \frac{1}{f}$$

For convex lenses f is negative; when parallel rays fall upon a concave lens the rays diverge after refraction, but the *virtual* focus is on the same side of the lens as that from which the light comes, hence for concave lenses f is positive.

564. **Particular cases.**—Fig. 539 illustrates the case in which the incident rays LB, MN, &c., are parallel to the principal axis. F, the point to which they converge on the other side of the lens, is the principal focus. There is of course a similar principal focus on the left-hand side of the lens, to which

parallel rays would converge if they came from the right. In the figure the rays are drawn as if they were incident at all parts of the lens from the centre to the edge, but in practice it is only the central part of the lens which is used; unless the angle DFE is confined to 10° or 12° , the refracted rays do not even approximately pass through a single point.

If the incident rays start from a point L on the principal axis (fig.

540), which is at a finite distance than the lens but beyond the principal focus, the point of convergence is at l , also on the principal axis, but farther

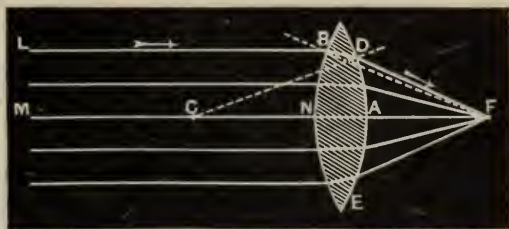

Fig. 539

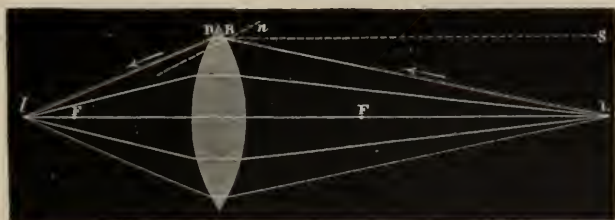

Fig. 540

away than F ; L and l are called conjugate foci, for if either is a source of light the other is its image.

As the point of light comes nearer the lens, the convergence of the emergent rays decreases, and the focus l becomes more distant; when the point L coincides with the principal focus, the emergent rays on the other side are parallel to the axis, and there is no focus, or, what is the same thing, it is infinitely distant.

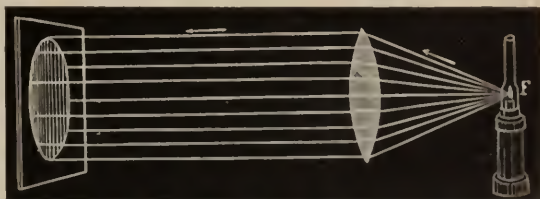

Fig. 541

As the refracted rays are parallel in this case, the intensity of light only decreases slowly, and a simple lamp can illuminate great distances. It is merely necessary to place it in the focus of a double convex lens, as shown in fig. 541.

Virtual foci.—When a luminous point is placed between the lens and its principal focus, the image or focus of the point is virtual, as shown in fig. 542. In this case the incident rays make with the normal greater angles than

those made with the rays FI from the principal focus; hence, when the former rays emerge, they move farther from the axis than the latter, and form a diverging pencil, HK, GM. These rays cannot produce a real image, but their prolongations intersect in some point, l , on the axis, and this point is the virtual focus of the point L (535).

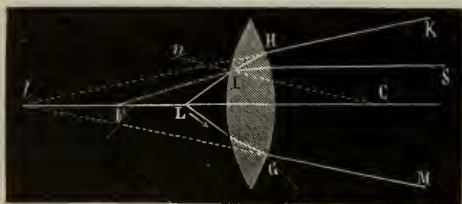

Fig. 542

565. Concave lenses.

In concave or diverging lenses there are only virtual foci, whatever the distance of the object. Let SS' be any pencil of rays parallel to the axis (fig. 543); any ray, SI , is refracted at the point of

incidence, I , and approaches the normal, CI . At the point of emergence it is also refracted, but diverges from the normal GC' , so that it is twice refracted in a direction which moves it from the axis, CC' . As the same thing takes place for every other ray, $S'KMN$, it follows that the rays, after

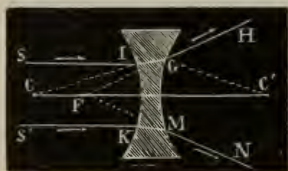

Fig. 543

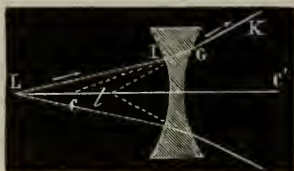

Fig. 544

traversing the lens, form a diverging pencil, $GHMN$. Hence there is no real focus, but the prolongations of these rays cut one another in a point F , which is the principal virtual focus.

In the case in which the rays proceed from a point, L (fig. 544), on the axis, it is found by the same construction that a virtual focus is formed at l , which is between the principal focus and the lens.

566. Optical centre, secondary axis.—In or near every lens there is a point called the *optical centre*, which is situate on the axis, and which has the property that any luminous ray passing through it experiences no angular deviation; that is, that the emergent ray is parallel to the incident ray. The existence of this point may be demonstrated in the following manner:—Let two parallel radii of curvature, CA and $C'A'$ (fig. 545), be drawn to the two surfaces of a double convex lens. Since the two tangent planes to the surface of the lens at A and A' are parallel, as being perpendicular to two parallel right lines, it will be granted that the refracted ray AA' is propagated in a medium with parallel faces. Hence a ray KA , which reaches A at such an inclination that after refraction it takes the direction AA' , will emerge parallel to its first direction (533); the point O , at which the right line cuts the axis, is therefore the optical centre. The position of this point may be determined for the case in which the curvature of the two faces is the same, which is the usual condition, by observing that the triangles COA and

$C'OA'$ are equal, and therefore that $OC = OC'$, which gives the point O . If the curvatures are unequal, the triangles COA and COA' are similar, and either CO or $C'O$ may be found, and therefore also the point O .

In double concave or meniscus lenses the optical centre may be determined by the same construction. In lenses with a plane face this point is at the intersection of the axis by the curved face.

Every right line, PP' (fig. 546), which passes through the optical centre without passing through the centres of curvature, is a *secondary axis*. As

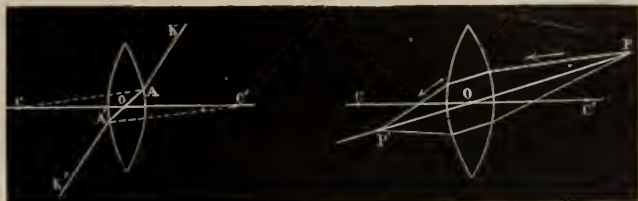

Fig. 545

Fig. 546

in all cases here considered the thickness of the lens is supposed to be extremely small, we may, in determining geometrically the positions of images, consider the optical centre to lie halfway between the two surfaces of the lens, and that rays passing through the optical centre suffer no bending or displacement.

So long as the secondary axes only make a small angle with the principal axis, all that has hitherto been said about the principal axis is applicable to them; that is, that rays emitted from a point P (fig. 546) on the secondary axis PP' nearly converge to a certain point of the axis, P' , and according as the distance from the point P to the lens is greater or less than the focal length, the image thus formed will be conjugate or virtual, and that the formula already investigated for points on the principal axis applies also to secondary axes. This principle is the basis of what follows as to the formation of images.

567. **Formation of images by convex lenses.**—In lenses, as well as in mirrors, the image of an object is the collection of the images of its several points; hence the determination of the images furnished by lenses resolves itself into determining the position of a series of points, as was the case with mirrors (537).

i. *Real image.*—

Let AB (fig. 547) be placed beyond the principal focus. Of the rays from the point A which fall upon the lens, that which passes through the centre undergoes no bending. If AC is drawn parallel to the principal axis, it will

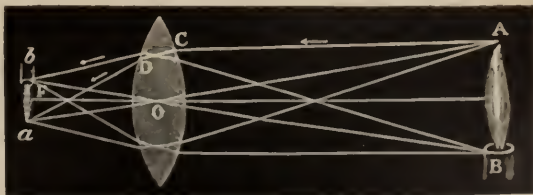

Fig. 547

after refraction pass through F, the principal focus. The rays DF and AO meet at a , which is therefore the image of A.

Proceeding similarly with the rays from B, we shall find that after refraction they meet in the point b , which is therefore the image, or conjugate focus, of B; and as the points between A and B have their foci between a and b , a *real* but *inverted* image of AB will be formed at ab . This image may be received on a white screen, on which it will be depicted, or the eye may be placed in the path of the rays emerging from it.

Conversely, if ab were the luminous or illuminated object, its image would be formed at AB. Two consequences important for the theory of optical instruments follow from this:—viz. 1st, *if an object, even a very large one, is at a sufficient distance from a double convex lens, the real and inverted image which is obtained of it is very small—it is near the principal focus, but somewhat beyond it*; 2nd, *if a very small object be placed near the principal focus, but a little in front of it, the image which is formed is at a great distance—it is much larger, and that in proportion as the object is near the principal focus*. In all cases the object and the image are in the same proportion as their distances from the lens.

These two principles are experimentally confirmed by receiving on a screen the image of a lighted candle, placed successively at various distances from a double convex lens.

ii. *Virtual image*.—There is another case in which the object AB (fig. 548) is placed between the lens and its principal focus. All rays from A which fall upon the lens diverge on emerging from the second face, as if from some point a . We can find this point most easily by drawing a ray, AC, parallel

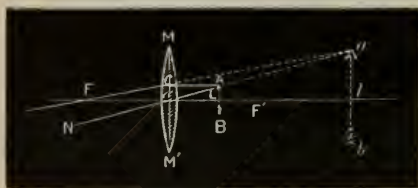

Fig. 548

to the principal axis, and another, through the centre of the lens; the latter suffers no bending, the former after refraction passes through F, the principal focus. The divergent rays CF, AN, on being produced backwards, meet at a , the position of which is thus found. Tracing the rays from B in the same way, its virtual

image will be found at b . There is therefore a *virtual* image of AB at ab ; *it is erect, and larger than the object*.

The magnifying power (540) is greater in proportion as the lens is more

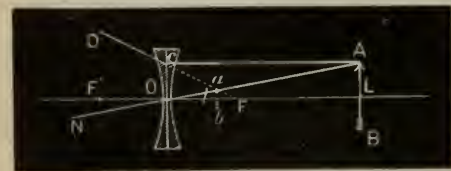

Fig. 549

convex, and the object nearer the principal focus. We shall presently show how the magnifying power may be calculated by means of the formulæ relating to lenses (569). Convex lenses, used in this manner as magnifying glasses, are called *simple microscopes*.

568. **Formation of images in concave lenses.**—A concave lens, like a convex mirror, only gives virtual images, whatever the distance of the object.

Let AB (fig. 549) be an object placed in front of such a lens. From A draw two rays, one parallel to the principal axis, which emerges from the other side of the lens as if coming from F, the principal focus; the other through the centre of the lens. The prolongations backwards of these meet at *a*, which is therefore the image (virtual) of A. Similarly for B and other points of the object. Thus, an eye receiving the rays emerging from the left-hand side of the lens sees the image of AB at *ab*, erect, virtual, and diminished.

569. Discussion of formulæ.—i. *Convex lens*.—In the case of a convex lens, *f* is negative, and the formula connecting *p* and *p'* is

$$\frac{1}{p'} - \frac{1}{p} = -\frac{1}{f}, \text{ or } p' = \frac{pf}{f-p} = \frac{f}{\frac{f}{p} - 1}.$$

If *p* is infinite, $\frac{f}{p} = 0$ and $p' = -f$; that is, the refracted rays intersect at the principal focus on the negative side. If $p = 2f$, $p' = -2f$; hence, if the object is placed at a distance from the lens equal to twice the focal length, the image is the same distance on the other side. Also, since

$$\frac{\text{size of image (linear)}}{\text{size of object (linear)}} = \text{magnification} = \frac{p'}{p},$$

it follows that the image is in this case the same size as the object, or the magnification is unity. If $p > 2f$, $p' < 2f$, and the image is diminished. If $p > f$ and $< 2f$, p' is between $-2f$ and negative infinity, *i.e.* there is magnification. When $p = f$, $p' = \infty$, the emergent rays being parallel. When $p < f$ the image is on the positive side of the lens, and is virtual and enlarged; *e.g.* if

$$p = \frac{f}{2}, \quad p' = \frac{\frac{f^2}{2}}{f - \frac{f}{2}} = f.$$

If the rays which fall upon the lens instead of diverging from a luminous object are converging, the object may be considered as virtual, *p* is negative, and $p' = \frac{-pf}{f+p}$, *i.e.* the image (always virtual) is on the negative side and less than the object.

ii. *Concave lens*.—In the case of concave lenses *f* is positive, and $p' = \frac{pf}{p+f}$, from which it is seen that, whatever the numerical values of *p* and *f*, *p'* is always positive so long as *p* is positive. When

$$\begin{aligned} p = \infty, & \quad p' = f \\ p = 2f, & \quad p' = \frac{2}{3}f \\ p = f, & \quad p' = \frac{1}{2}f. \end{aligned}$$

Thus the virtual image of a real object formed by a concave lens is always between the lens and the principal focus, and is always diminished. But if the object is virtual—in other words, if the rays which fall upon the first face of the lens would, but for the lens, meet on the negative side

of the lens—then $p' = \frac{pf}{f-p}$, where p is the numerical value of the distance of the point of convergence of the incident rays from the lens. Suppose p to be a little less than f , say $\frac{5}{6}f$, then $p' = \frac{\frac{5}{6}f^2}{f - \frac{5}{6}f} = 5f$ and the magnification = $\frac{p'}{p} = \frac{5f}{\frac{5}{6}f} = 6$, and the nearer p is to f the greater the magnification.

It will further be noted that the image is on the positive side of the lens, or on the opposite side to that on which the incident rays are converging. This is a practical case which we shall meet with again in Galileo's telescope (608).

iii. *The formula* $\frac{1}{f} = (n-1) \left(\frac{1}{r} - \frac{1}{s} \right)$.—Consider the lenses M, N, . . . R in art. 562, and suppose, as before, light to be incident on the right-hand side of the lens; r and s are the radii of the first and second surfaces on which the light falls, and both are positive if measured to the right.

$$\text{Hence, for M, } \frac{1}{f} = (n-1) \left(-\frac{1}{r} - \frac{1}{s} \right) = -(n-1) \left(\frac{1}{r} + \frac{1}{s} \right),$$

$$\text{N, } \frac{1}{f} = (n-1) \left(-\frac{1}{r} - 0 \right) = -(n-1) \frac{1}{r},$$

$$\text{O, } \frac{1}{f} = (n-1) \left(-\frac{1}{r} + \frac{1}{s} \right) = -(n-1) \left(\frac{1}{r} - \frac{1}{s} \right);$$

in the last case $s > r$, and therefore for all convex lenses f is negative. Similarly for the concave lenses P, Q, R, f is positive.

570. **Spherical aberration. Caustics.**—In speaking about foci, and about the images formed by different kinds of spherical lenses, it has been hitherto assumed that the rays emitted from a single point intersect also after refraction in a single point. This is virtually the case with a lens whose *aperture*—that is, the angle obtained by joining the edges to the principal focus—does not exceed 10° or 12° .

Where, however, the aperture is larger, the rays which traverse the lens near the edge are refracted to a point F (fig. 550) nearer the lens than the point

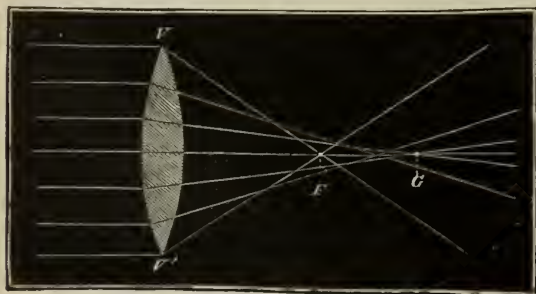

Fig. 550

G, which is the focus of the rays which pass near the axis. The phenomenon thus produced is named *spherical aberration by refraction*; it is analogous to the spherical aberration produced by reflection (542). The luminous surfaces formed by the

intersection of the refracted rays are termed *caustics by refraction*.

Spherical aberration is prejudicial to the sharpness and definition of an

image. If the image of an object produced by a convex lens is received on a ground-glass screen, and is sharply defined in the centre, it will be indistinct at the edges; and, *vice versa*, if the image is sharp at the edges, it will be indistinct in the centre. This defect is very objectionable, more especially in lenses used for photography. It is partially obviated by placing in front of the lenses diaphragms provided with a central aperture called *stops*, which admit the rays passing near the centre, but cut off those which pass near the edges. The image thereby becomes sharper and more distinct, though the illumination is less.

If a screen is held between the light and double convex lens, which quite covers the lens, but has two concentric series of holes, two images are obtained, and may be received on a sheet of paper. By closing one or the other series of holes by a flat paper ring, it can be easily ascertained which image arises from the central, and which from the marginal rays. When the paper is at a small distance the marginal rays produce the image in a point, and the central ones in a ring; the former are converged to a point, and the latter not. At a somewhat greater distance the marginal rays produce a ring, and the central ones a point. It is thus shown that the focus of the marginal rays is nearer the lens than that of the central rays.

Spherical aberration is diminished by substituting for a lens of short focus two lenses of double focal length, which are placed at a little distance apart. Greater length of focus has the result that for the same diameter the aperture and also the aberration are less; and as it is not necessary to stop a great part of the lens there is a gain in luminosity, which is not purchased by indistinctness of the images, while the combination of the two lenses produces the same amount of convergence as is produced by the single lens (571). Lenses which are free from spherical aberration are called *aplanatic*.

571. **Combination of lenses.**—If parallel rays fall on a convex or concave lens A, which has the focal length f , and then on a lens B, convex or concave, with the focal distance f' , at a distance d from A, and the distance from the lens B at which the image is formed is F; then

$$\frac{1}{F} = \frac{1}{f'} + \frac{1}{f + d}.$$

If the lenses are close together, so that $d = 0$,

$$\frac{1}{F} = \frac{1}{f} + \frac{1}{f'}.$$

If the lenses have the same curvature, that is $f = f'$, then $\frac{1}{F} = \frac{2}{f}$; that is to say, the focal length of the combination is half that of the single lenses.

If A is convex and B concave, f is negative and f' positive. Hence

$$\frac{1}{F} = -\frac{1}{f} + \frac{1}{f'} = \frac{f - f'}{ff'};$$

thus, as the focal length of the convex lens is greater or less than that of the concave, the combination is concave or convex. By the aid of this formula we can determine the focal length of a concave lens by combining with it a convex lens of such convexity that the combination is convex.

The reciprocal of the focal length is called the *power* of the lens. The power of a combination of two lenses in contact is the sum of the powers of the separate lenses.

572. **Determination of the focal length of a lens, and of the refractive index of its material.**—i. *Convex lens.*—(a) Let the lens be exposed to the sun's rays so that they are parallel to its axis. The emergent pencil being received on a ground-glass screen, the point to which the rays converge is readily seen; it is the principal focus. A stop should be used to cut off all rays except those near the centre.

(b) If a luminous object, such as a candle or gas flame, is placed on one side the lens and a screen on the other, and the screen is moved until a sharp image of the object is formed on it, the focal length may be determined from the formula $\frac{1}{p'} - \frac{1}{p} = \frac{1}{f}$. If we consider p , p' , and f to be all positive quantities, we must change the signs of p' and f ; thus the formula becomes $\frac{1}{p} + \frac{1}{p'} = \frac{1}{f}$, where now p , p' , and f are mere numerical lengths without regard to the direction in which they are drawn. When p and p' are measured, the value of f is at once deduced.

(c) In the last arrangement we may alter the relative positions of lens and screen so that the object and image are the same size; each is then distant $2f$ from the lens, and so, to obtain f , we divide the distance between the object and the image by 4.

(d) Another method is to place on one side of the lens, and a little beyond its principal focus, a brightly illuminated scale, which is best of glass, on which a strong light falls; on the other side a screen is placed at such a distance as to produce a greatly magnified distinct image of the scale. Then if l and L are the lengths of the scale and its image respectively, and d the distance of the screen from the lens,

$$f = d \frac{l}{l + L}.$$

ii. *Concave lens.*—We have already (571) indicated a method by which the focal length of a concave lens may be found. It depends upon our being able to employ, in contact with the concave lens, a convex lens of sufficient power to render the combination convex. The focal lengths of the single convex lens and of the combination are determined by one of the methods given above, and that of the concave lens deduced from the formula $\frac{1}{F} = \frac{1}{f_1} + \frac{1}{f_2}$. If f_1 and F refer to the convex lens and to the combination respectively, each must have the negative sign prefixed; whence

$$\frac{1}{f_2} = \frac{1}{f_1} - \frac{1}{F} = \frac{F - f_1}{f_1 F},$$

and this is positive since $F > f_1$.

iii. *Refractive index.*—We can measure the curvatures of the two faces of a lens by a small spherometer (11 and 539), and its focal length by one of the above methods. The formula $\frac{1}{f} = (n - 1) \left(\frac{1}{r} - \frac{1}{s} \right)$ then enables us to find n , the refractive index of the glass.

573. **Laryngoscope.**—As an application of lenses may be adduced the *laryngoscope*, which is an instrument invented to facilitate the investigation of the larynx and other cavities of the mouth. It consists of a plano-convex lens L, and a concave reflector M, both fixed to a ring which can be adjusted to any convenient lamp (fig. 551). The flame of a lamp is in the

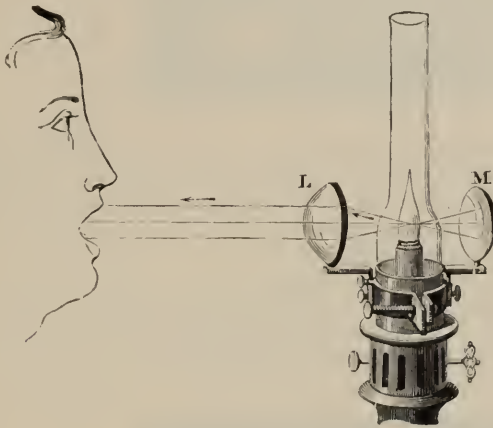

Fig. 551

principal focus of the lens, and at the same time is at the centre of curvature of the reflector. Hence the divergent pencil proceeding from the lamp to the lens is changed after emerging into a parallel pencil. Moreover, the pencil from the lamp, impinging upon the mirror, is reflected to the focus of the lens, and traverses the lens, forming a second parallel pencil which is superposed on the first. This being directed into the mouth of a patient, its condition may be readily observed.

CHAPTER IV

DISPERSION AND ACHROMATISM

574. **Decomposition of white light. Solar spectrum.**—The phenomenon of refraction is by no means so simple as we have hitherto assumed. When *white* light, or that which reaches us from the sun, passes from one medium into another, *it is decomposed into several kinds of light*, a phenomenon to which the name *dispersion* is given.

In order to show that white light is decomposed by refraction, a pencil of the sun's rays, SA (fig. 552), is allowed to pass through a small aperture in the window shutter of a dark chamber, as in Newton's original experiment. This pencil tends to form an oval and colourless image of the sun at K ;

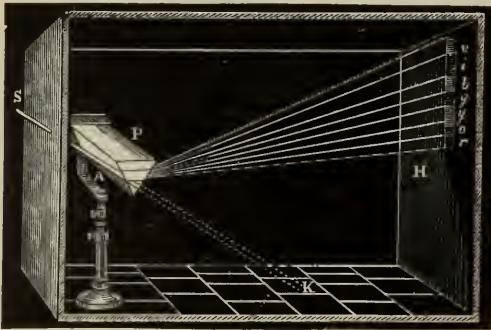

Fig. 552

but if a flint-glass prism arranged horizontally is interposed in its path, the beam, on emerging from the prism, becomes refracted towards its base, and produces on a distant screen a vertical band rounded at the ends, coloured in all the tints of the rainbow, which is called the *solar spectrum* (see Plate I.). In this spectrum there is, in reality, an infinity of different tints, which

imperceptibly merge into each other, but it is customary to distinguish seven principal colours. These are *violet, indigo, blue, green, yellow, orange, red* ; they are arranged in this order in the spectrum, the violet being the most refrangible, and the red the least so. They do not all occupy an equal extent in the spectrum, violet having the greatest extent, and orange the least.

575. **The colours of the spectrum are simple, and unequally refrangible.**—If one of the colours of the spectrum is isolated by intercepting the others by means of a screen E, as shown in fig. 553, and if the light thus isolated is allowed to pass through a second prism, B, a refraction will be observed, but the light remains unchanged ; that is, the image received on the screen H is violet if the violet pencil has been allowed to pass, blue if the blue pencil, and so on. Hence the colours of the spectrum are *simple* ; that is, they cannot be further decomposed by the prism.

Moreover, the colours of the spectrum are unequally refrangible; that is, the glass of the prism possesses a different refractive index for each of the rays of which white light is composed. The elongated shape of the spectrum would be sufficient to prove the unequal refrangibility of the simple colours, for it is clear that the violet, which is most deflected



Fig. 553

towards the base of the prism, is also most refrangible; and that red, which is least deflected, is least refrangible. But the unequal refrangibility of simple colours may be shown by numerous experiments, of which the two following may be adduced:—

i. Two narrow strips of coloured paper, red and violet, are fastened close to each other on a sheet of black paper. On looking at them through a prism, they are seen to be unequally displaced, the red band to a less extent than the violet; hence the red rays are less refrangible than the violet.

ii. The same conclusion may be drawn from Newton's experiment with crossed prisms. On a prism A (fig. 554), in a horizontal position, a pencil of white light, S, is received, which, if it merely traverses the prism A, will form the spectrum rv , on a distant screen. But if a second prism, B, is placed in a vertical position behind the first,

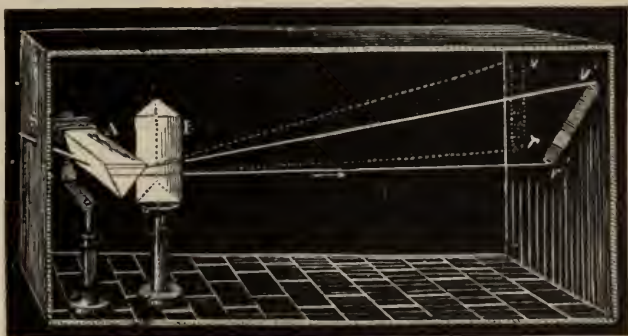

Fig. 554

in such a manner that the refracted pencil passes through it, the spectrum rv becomes deflected towards the base of the vertical prism; but, instead of being deflected in a direction parallel to itself, as would be the case if the colours of the spectrum were equally refracted, it is obliquely refracted in the direction $r'v'$, proving that from red to violet the colours are more and more refrangible.

These different experiments show that the refractive index differs in different colours; even rays which are to perception indistinguishable may differ in refrangibility. In the red band, for instance, the rays at the extremity of the spectrum are less refracted than those which are nearer the orange zone.

576. **Production of a pure solar spectrum.**—In the above experiment the spectrum formed is built up of a series of overlapping coloured images of the sun, and the colours are confused and indistinct. In order to obtain a pure spectrum, the slit, in the shutter of the dark room through which light enters, should be of rectangular form, from 15 to 25 mm. in height and from 1 to 2 mm. in breadth. The sun's rays are directed upon the slit by a mirror, or still better by a heliostat (543). An achromatic double convex lens is placed at a distance from the slit of double its own focal length, which should be about a metre, and a screen is placed at the same distance from the lens. An image of the slit of exactly the same size is thus formed on the screen (569). If now there is placed near the lens, between it and the screen, a prism with an angle of about 60° , and with its refracting edge parallel to the slit, a very beautiful, sharp, and pure spectrum is formed on the screen. The prism should be placed so that it produces the minimum deviation for the mean rays.

577. **Dispersive power.**—With transparent prisms of different substances, or with hollow glass prisms filled with various colourless liquids, spectra are obtained formed of the same colours, and in the same order; but when the mean deviation produced is the same, the length of the spectrum varies with the substance of which the prism is made. The angle of separation of two selected rays (say in the red and the violet) produced by a prism is called the *dispersion*, and the ratio of this angle to the mean deviation of the two rays is called the *dispersive power*. This ratio is constant for the same substance so long as the refracting angle of the prism is small. For the deviation of the two rays is proportional to the refracting angle; their difference and their mean vary in the same manner, and therefore the ratio of their difference to their mean is constant.

The spectra which are formed by artificial lights rarely contain all the colours of the solar spectrum; but their colours are found in the solar spectrum, and in the same order. Their relative intensity is also modified. The shade of colour which predominates in the flame predominates also in the spectrum; yellow, red, and green flames produce spectra in which the dominant tint is yellow, red, or green.

The formula for a prism, $n \sin \frac{A}{2} = \sin \frac{A+d}{2}$ (558), may, if A is small enough, be written $n \frac{A}{2} = \frac{A+d}{2}$, or, $d = A(n-1)$. Hence, if n_H is the refractive index of the material of a lens for violet rays, n_A the refractive index for red rays, and n for mean rays, and if d_H, d_A, d be the corresponding deviations, we have

$$\text{Dispersive power} = \frac{d_H - d_A}{d} = \frac{n_H - n_A}{n - 1}.$$

From the table given in art. 561 we see that

for light crown glass $n_H - n_A = \cdot 021$, and $n - 1$ (for D line) = $\cdot 575$

„ „ flint „ $n_H - n_A = \cdot 041$, and $n - 1$ „ = $\cdot 609$

therefore, the dispersive power of crown glass = $\frac{21}{575} = \cdot 0365$

flint „ = $\frac{41}{609} = \cdot 0673$

that is, the dispersive power of flint is nearly twice as great as that of crown glass.

578. **Recomposition of white light.**—Not merely can white light be resolved into rays of various colours, but by combining the different pencils separated by the prism white light can be reproduced. This may be effected in various ways.



Fig. 555

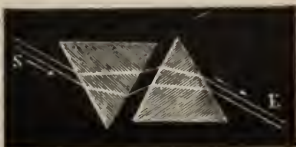

Fig. 556

i. If the spectrum produced by one prism is allowed to fall upon a second of the same material and the same refracting angle as the first, but inverted as shown in fig. 556,

the latter reunites the different colours of the spectrum, and it is seen that the emergent pencil E, which is parallel to the pencil S, is colourless.

ii. If the spectrum falls upon a double convex lens (fig. 555), a white image of the sun will be formed on a white screen placed in the focus of the lens; a glass globe filled with water produces the same effect as the lens.

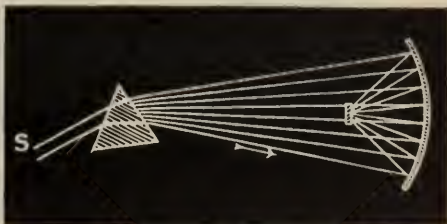

Fig. 557

iii. If the spectrum falls upon a concave mirror, a white image is formed on a screen of ground glass placed in its focus (fig. 557).

iv. Light may be recomposed by an experiment, which consists in receiving the seven colours of the spectrum on seven small glass mirrors with plane faces; these mirrors can be so inclined in all positions that the reflected light may be transmitted in any given direction (fig. 558).

When the mirrors are suitably arranged, the seven reflected pencils may be caused to fall on the ceiling, so as to form seven distinct images—red, orange, yellow, &c. When

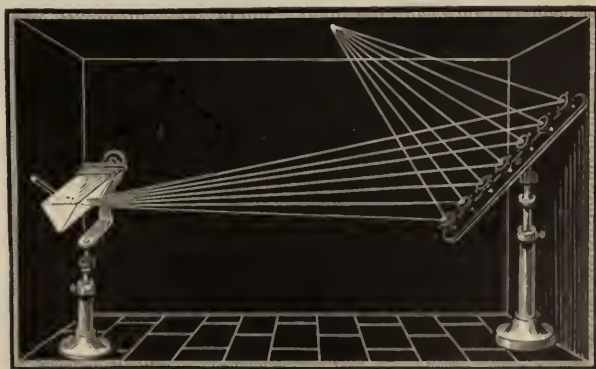

Fig. 558

When the mirrors are suitably arranged, the seven reflected pencils may be caused to fall on the ceiling, so as to form seven distinct images—red, orange, yellow, &c. When

the mirrors are moved so that the separate images become superposed, a single image is obtained, which is white.

v. By means of *Newton's disc* (fig. 559) it may be shown that the seven colours of the spectrum form white. This is a cardboard disc of about a foot in diameter; the centre and the edges are covered with black paper, while in the space between there are pasted strips of paper of the colours of the spectrum. They proceed from the centre to the circumference, and their relative dimensions and tints are such as to represent five spectra (fig. 560). When this disc is rapidly rotated, the effect is the same as if the retina received simultaneously the impression of the seven colours.

vi. If by a mechanical arrangement a prism, on which the sun's light falls, is made to oscillate rapidly, so that the spectrum also oscillates, the middle of the spectrum appears white.

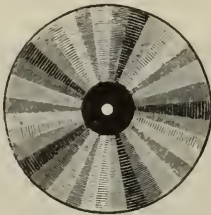

Fig. 560

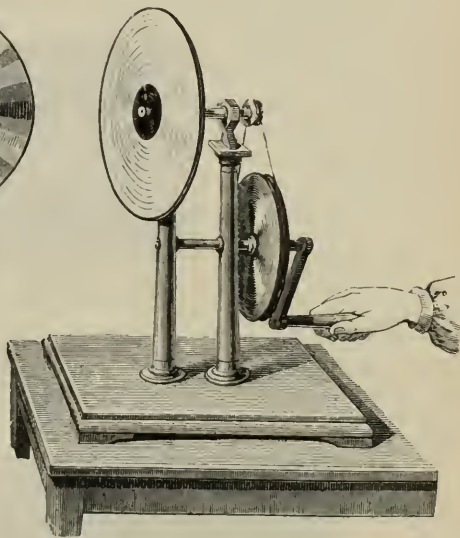

Fig. 559

These latter phenomena depend on the physiological fact that sensation always lasts a little longer than the impression from which it results (639). If a new impression is allowed to act, before the sensation arising from the former one has ceased, a sensation is obtained consisting of two impressions. And by choosing the time short enough, three, four, or more impressions may be mixed with each other. With a rapid rotation the disc (fig. 559) is nearly white. It is not quite so, for the colours cannot be exactly arranged in the same proportions as those in which they exist in the spectrum, and moreover *pigment* colours are not pure (582).

579. **Newton's theory of the composition of light.**—Newton was the first to decompose white light by the prism, and to recompose it. From the various experiments which we have described, he concluded that white light was not homogeneous, but formed of seven lights unequally refrangible,

which he called *simple* or *primitive* lights. Owing to the difference in refrangibility they become separated in traversing the prism.

The designation of the various colours of the spectrum is to a very great extent arbitrary; for, in strict accuracy, the spectrum is made up of an infinite number of simple colours, which pass into one another by imperceptible gradations of colour and refrangibility.

580. **Colour of bodies.**—The natural colour of bodies results from the fact that one portion of the coloured rays contained in white light is absorbed at the surface of the body. If the unabsorbed portion traverses the body, the latter is coloured and transparent; if, on the contrary, it is reflected, the body is coloured and opaque. In other words, reflection is ordinarily not a mere surface action; the incident light penetrates to some slight extent into the substance of the body, is reflected and emerges, but deprived of those constituents which the body absorbs. In all cases the colour results from the constituents which have not been absorbed. Those which reflect or transmit all colours in the proportion in which they exist in the spectrum are white; those which reflect or transmit none are black. Between these two limits there are infinite tints according to the greater or less extent to which bodies reflect or transmit some colours and absorb others. Thus a body appears yellow because it absorbs all colours with the exception of yellow. In like manner, a solution of ammoniacal copper sulphate absorbs preferably the red and yellow rays, transmits the blue rays almost completely, the green and violet less so; hence the light seen through it is blue.

Accordingly bodies have no colour of their own; the colour changes with the nature of the incident light. Thus a white body in a dark room, if successively illuminated by each of the colours of the spectrum, has no special colour, but appears red, orange, green, &c., according to the position in which it is placed. If monochromatic light falls upon a body, it appears brighter in the colour of this light if it does not absorb this colour; but black if it does absorb it. In the light of a lamp fed by spirit in which some common salt is dissolved, everything white and yellow seems bright, while other colours, such as vermilion, ultramarine, and malachite, are black. This is seen in the case of a stick of red sealing-wax viewed in such a light. In the light of lamps and of candles, which from the want of blue rays appear yellow, yellow and white appear the same, and blue seems like green. In bright twilight or in moonshine the light of coal gas has a reddish tint.

581. Mixed colours. Complementary colours.

By mixed colours we understand the impression of colour which results from the coincident action of two or more colours on the same portion of the retina. This new impression is single; it cannot be resolved into its components; in this respect it differs from a complex sound, in which the ear, by practice, can learn to distinguish the constituents. Mixed colours may be produced by *Lambert's method*, which consists in looking in an oblique direction through a vertical glass plate P (fig. 561) at a coloured wafer *b*, while, at the same time, a wafer of another colour, *g*,

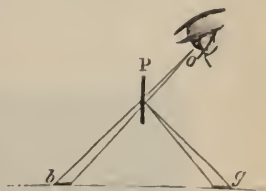

Fig. 561

sends its light by reflection towards the observer's eye ; if g is placed in a proper position, which is easily found by trial, its image exactly coincides with that of b . The method of the colour disc (578) affords another means of producing mixed colours.

A very convenient way of investigating the phenomena of mixed colours is that of *Maxwell's colour-discs*. These consist of discs of cardboard with an aperture in the centre, by which they can be fastened on the spindle of the turning-table (fig. 562). Each disc is painted with a separate colour,

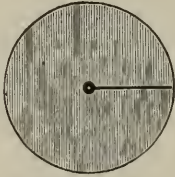

Fig. 562

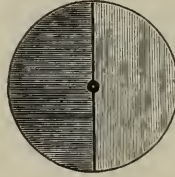

Fig. 563

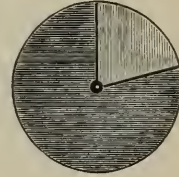

Fig. 564

and, having a radial slit, they may be slid over each other so as to overlap to any desired extent (figs. 563 and 564) ; and thus, when in this way two such discs are rotated, we get the effect due to this mixture of these two colours. It is clear also that the effect of three colours may be investigated in the same way.

If, in any of the methods by which the impression of mixed spectral colours is produced, one or more colours are suppressed, the residue corresponds to one of the tints of the spectrum ; and the mixture of the colours taken away produces the impression of another spectral colour. Thus, if in fig. 555 the red rays are cut off from the lens L , the light on the focus is no longer white, but greenish blue. In like manner, if the violet, indigo, and blue of the colour disc are suppressed, the rest seems yellow, while the mixture of that which has been taken out is a bluish violet. Hence white can always be compounded of *two* tints ; and two tints which together give white are called *complementary colours*. Thus of spectral tints *red* and *greenish blue* are complementary ; so are *orange* and *Prussian blue*, *yellow* and *indigo blue*, *greenish yellow* and *violet*.

The method by which Helmholtz investigated the mixture of spectral colours is as follows :—Two very narrow slits, A and B (fig. 565), at right



Fig. 565

angles to each other, are made in the shutter of a dark room ; at a distance from this is placed a powerfully dispersing prism with its refracting edge vertical. When the slits are viewed through a telescope, the slit B gives the oblique spectrum LM , while the slit A gives the spectrum ST . These two spectra partially overlap, and when this is the case *two homogeneous spectral*

colours mix. Thus at 1 the red of one spectrum coincides with the green of the other ; at 3, indigo and yellow coincide ; and so forth.

When the experiment is made with suitable precautions, the colours obtained by mixing the spectral colours will be found in the following table, where the fundamental spectra to be mixed are given in the first horizontal and vertical column, and the resultant colours where these cross.

	Violet	Blue	Green	Yellow	Red
Red	Purple	Rose	Dull yellow	Orange	Red
Yellow	Rose	White	Yellowish green	Yellow	
Green	Fale blue	Bluish green	Green		
Blue	Indigo	Blue			
Violet	Violet				

Prismatic spectrum colours may also be investigated by the method of von Bezold, which consists in producing two images of colours by double refraction, and making one cover the other.

The mixture of mixed colours gives rise to no new colours. Only the same colours are obtained as a mixture of the primitive spectral colours would yield, except that they are less *saturated*, as it is called ; that is, more mixed with white.

582. **Spectrum colours and pigment colours.**—A distinction must be made between *spectrum colours* and *pigment colours*. Thus a mixture of pigment yellow and pigment blue produces green, and not white, as is the case when the blue and yellow of the spectrum are mixed. The reason of this is that in the mixture of pigments we have a case of subtraction of colours, and not of addition. For the pigment blue in the mixture absorbs almost entirely the yellow and red light ; and the pigment yellow absorbs the blue and violet light, so that only the green remains.

In the above series are two spectral colours very remote in the spectrum, which have nearly the same complementary tints ; red, the complementary colour to which is greenish blue ; and violet, whose complementary colour is greenish yellow. Now when two pairs of complementary colours are mixed together they must produce white, just as if only two complementary colours were mixed. But a mixture of greenish blue and of greenish yellow is green. Hence from a mixture of red, green, and violet, white must be formed. This may easily be ascertained to be the case by means of a colour disc on which are these three colours in suitable proportions.

From the above facts it follows that from a mixture of red, green, and

violet all possible colours may be constructed, and hence these three spectral colours are called the *fundamental colours*. It must be remarked that the tints resulting from the mixture of these three have never the saturation of the individual spectral colours.

We have to discriminate three points in regard to *colour*. In the first place, the *tint*, or colour proper, by which we mean that special property which is due to a definite refrangibility of the rays producing it; secondly, the *saturation*, which depends on the greater or less admixture of white light with the colours of the spectrum, these being colours which are fully saturated; and thirdly, there is the *intensity* or brightness of the colour.

583. **Homogeneous light.**—The light emitted from luminous bodies is seldom or never quite pure; on being examined by the prism it will be found to contain more than one colour. In optical researches it is frequently of great importance to procure *homogeneous* or *monochromatic* light. Common salt, or, still better, sodium bromide, in the flame of a Bunsen's lamp gives a yellow of great purity. For red light, ordinary light is transmitted through glass coloured with copper suboxide, which absorbs nearly all the rays excepting the red. A very pure blue is obtained by transmitting ordinary light through a glass trough containing an ammoniacal solution of copper sulphate, and a nearly pure red by transmitting it through a solution of iron sulphocyanide.

584. **Properties of the spectrum.**—Besides its luminous properties, the spectrum is found to produce calorific and chemical effects.

Luminous properties. It appears from the experiments of Fraunhofer and of Herschel that the light in the yellow part of the spectrum has the greatest intensity, and that in the violet the least.

Heating effects. It was long known that the various parts of the spectrum differed in their calorific effects. Leslie found that a thermometer placed in different parts of the spectrum indicated a higher temperature as it moved from violet towards red. Herschel fixed the maximum intensity of the heating effects just outside the red; Berard in the red itself. Seebeck showed that these different results are affected by the nature of the prism used; with a prism of water the greatest calorific effect is produced in the yellow; with one of alcohol it is in the orange-yellow; and with a prism of crown glass it is in the middle of the red.

Melloni, by using prisms and lenses of rock salt, and by availing himself of the extreme delicacy of the thermo-electric apparatus, first made a complete investigation of the calorific properties of the thermal spectrum. This result led, as we have seen, to the confirmation and extension of Seebeck's observations. The results of the researches of Tyndall and Langley on the heat of the spectrum are given in articles 435 and 436.

Chemical properties. In numerous phenomena, light exerts a chemical action. For instance, silver chloride blackens under the influence of light; transparent phosphorus becomes opaque; vegetable colouring matters fade; hydrogen and chlorine gases, when mixed, combine slowly in diffused light, and with explosive violence when exposed to direct sunlight. The chemical action differs in different parts of the spectrum. Scheele found that when silver chloride was placed in the violet, the action was more energetic than in any other part. Wollaston observed that the action extended beyond

the violet, and concluded that, besides the visible rays, there are some invisible and more highly refrangible rays. These are sometimes called the chemical or *actinic* rays (438).

The most remarkable chemical action which light exerts is in the growth of plant life. The vast masses of carbon and hydrogen accumulated in the vegetable world owe their origin to the carbonic acid and aqueous vapour present in the atmosphere. The light which is absorbed by the green parts of plants acts as a reducing agent. The reduction does not extend to the complete isolation of carbon and hydrogen, and the individual stages of the process are unknown to us; but the general result is, undoubtedly, that under the influence of the sun's rays the chemical attraction which holds together the carbon and oxygen is overcome; the carbon, which is set free, assimilates at that moment the elements of water, forming cellulose or woody fibre, while the oxygen returns to the atmosphere in the form of gas. The equivalent of the sunlight which has been absorbed is to be sought in the chemical energy of the separated constituents. When we burn petroleum or coal, we reproduce, in some sense, the light which the sun has expended in former ages in the production of a primeval vegetable growth.

The researches of Bunsen and Roscoe show that whenever chemical action is induced by light, an absorption of light takes place, preferably of the more refrangible parts of the spectrum. Thus, when chlorine and hydrogen unite, under the action of light, to form hydrochloric acid, light is absorbed, and the quantity of chemically active rays consumed is directly proportional to the amount of chemical action.

There is a curious difference in the action of the different spectral rays. Moser placed an engraving on an iodised silver plate and exposed it to the light until an action had commenced, and then placed it under a violet glass in the sunlight. After a few minutes a picture was seen with great distinctness, while when placed under a red or yellow glass it required a very long time, and was very indistinct. When, however, the iodised silver plate was first exposed in a camera obscura to blue light for two minutes, and was then brought under a red or yellow glass, an image quickly appeared, but not when placed under a green glass. It appears as if there are vibrations of a certain frequency which can commence an action, and that there are others which are devoid of the property of commencing, but can continue and complete an action when once set up. Becquerel, who discovered these properties in luminous rays, called the former *exciting rays* and the latter *continuing* or *phosphorogenic rays*. The phosphorogenic rays, for instance, have the property of rendering certain objects self-luminous in the dark after they have been exposed for some time to the light.

585. **Dark lines of the solar spectrum.**—The colours of the solar spectrum are not continuous. For several grades of refrangibility rays are wanting, and, in consequence, throughout the whole extent of the spectrum there are a great number of very narrow dark lines. To observe them, a pencil of solar rays is admitted into a darkened room, through a narrow slit. At a distance of three or four yards we look at this slit through a prism of flint glass, which must be very free from flaws, taking care to hold its edge parallel to the slit. We then observe a great number of very delicate dark lines parallel to the edge of the prism, and at very unequal intervals.

The existence of the dark lines was first observed by Wollaston in 1802 ; but Fraunhofer, a celebrated optician of Munich, first studied and gave a detailed description of them. Fraunhofer mapped the lines, and indicated the most marked of them by the letters A, *a*, B, C, D, E, *b*, F, G, H ; they are therefore generally known as *Fraunhofer's lines*.

The dark line A (see fig. 11 of Plate I.) is at the middle, and B halfway between this and the end of the red portion ; C, at the boundary of the red and orange ; D is in the yellow region ; E, in the green ; F, in the blue ; G, in the indigo ; H, in the violet. There are certain other noticeable dark lines, such as *a* in the red and *b* in the green. In the case of sunlight the positions of most of the dark lines are fixed and definite ; on this account they are used for obtaining an exact determination of the refractive index of a transparent substance (559) for each colour ; only in this way is it possible accurately to define a colour ; for example, the refractive index of the blue ray is, strictly speaking, that of the dark line F. But some of the lines only appear as the sun nears the horizon, and others are strengthened. They are also influenced by the state of the atmosphere. The fixed lines are due to the sun ; the variable lines have been proved by Janssen and Secchi to be due to the aqueous vapour in the air, and are called *atmospheric* or *telluric* lines.

Fraunhofer counted in the spectrum more than 600 dark lines, more or less distinct, distributed irregularly from the extreme red to the extreme violet ray. Brewster counted 2000. By causing the refracted rays to pass successively through several analysing prisms (587), not merely has the existence of 3000 dark lines been ascertained, but several which had been supposed to be single have been shown to be compound. Thollon produced a spectrum 15 metres in length in which were 4000 dark lines.

586. **Bright line spectra.**—In 1822 Sir J. Herschel remarked that by volatilising substances in a flame a very delicate means is afforded of detecting certain ingredients by the bright lines they produce in the spectrum ; and Fox Talbot in 1834 suggested optical analysis as probably the most delicate means of detecting minute portions of a substance. To Kirchhoff and Bunsen, however, is really due the merit of basing a method of analysis on the observation of the lines of the spectrum. They ascertained that the salts of the same metal, when introduced into a flame, always produced bright lines identical in colour and position, but that lines different in colour, position, or number were produced by different metals ; and finally, that an exceedingly small quantity of a metal suffices to disclose its existence. Hence has arisen a new and powerful method of analysis, known by the name of *spectrum analysis*.

587. **Spectroscope.**—The name of spectroscope has been given to the apparatus employed by Kirchhoff and Bunsen for the study of the spectrum. One of the forms of this apparatus is represented in fig. 566. It is composed of three telescopes mounted on a common foot, whose axes converge towards a prism, P, of flint glass. The telescope A is the only one which can turn round the prism. It is fixed in any required position by a clamping screw *n*. The screw-head *m* is used to *focus* the eyepiece. The screw-head *n* serves to change the inclination of the axis.

To explain the use of the telescopes B and C we must refer to fig. 567

through a magnifying glass, which forms at ss' a virtual image of the spectrum magnified about eight times.

The telescope C serves to measure the relative distances of the lines of the spectrum. For this purpose a micrometer is placed at m , divided into 25 equal parts. A micrometer is formed thus :—A scale of 250 millimetres is divided with great exactness into 25 equal parts. A photographic negative on glass of this scale is taken, reduced to 15 millimetres. The negative is taken because then the scale is light on a dark ground. The scale is then placed at m in the principal focus of the lens e ; consequently, when the scale is lighted by the candle F, the rays emitted from it leave the lens e in parallel pencils; a portion of these, being reflected from a face of the prism, passes through the lens x , and forms a perfectly distinct image of the micrometer at the principal focus of x , so that the spectrum and the image of the micrometer scale are superposed in the same plane, thereby furnishing the means of measuring exactly the relative distances of the different spectral lines.

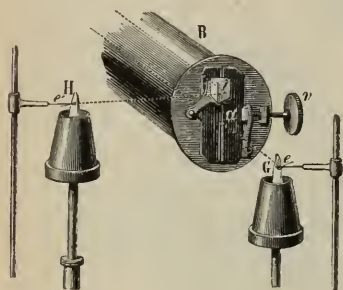

Fig. 568

The micrometric telescope C (fig. 566) is furnished with several adjusting screws, i , o , r ; of these, i adjusts the focus; o displaces the micrometer in the direction of the spectrum laterally;

r raises or lowers the micrometer, which it does by giving different inclinations to the telescope.

The opening whereby the light of the flame G enters the collimating telescope B consists of a narrow vertical slit, which can be opened more or less by causing the movable piece a to advance or recede by means of the screw v (fig. 568). When, for purposes of comparison, the spectra of two flames are to be examined simultaneously, a small right-angled prism is placed over the upper part of the slit. Rays from one of the flames, H, fall at right angles on one face of the prism; they then experience total reflection on a second face, and leave the prism by the third face, and in a direction at right angles to that face. By this means they pass into the telescope in a direction parallel to its axis, without in any degree mixing with the rays which proceed from the second flame, G. Consequently the two pencils of rays traverse the prism P (fig. 567), and form two horizontal spectra, which are viewed simultaneously through the telescope A. In the flames G and H are platinum wires, e , e' . These wires have been dipped beforehand into solutions of the salts of the metals on which experiment is to be made; and the vaporised metals of these salts give rise to definite lines.

For more detailed investigations of the spectral lines a *train of prisms* is used. Fig. 569 represents one with nine prisms. The light issuing from the collimator A passes in succession through each of the prisms. As the successive deviations add themselves the dispersion is very much increased, and a spectrum of great extent is obtained. It is, however, feebly luminous, owing partly to its extension, and partly to the loss of

light which is observed through the telescope B, which it undergoes in traversing all these refracting surfaces. In the case of ten prisms the loss of light has been found to amount to 99 per cent.

Christie has used with advantage a *semi-prism* obtained by cutting an isosceles prism by a plane at right angles to the base. These semi-prisms have the advantage that they produce as much dispersion as with several ordinary prisms without any appreciable loss in the sharpness of the images; and without that absorption of light which in the case of a number of prisms is so very considerable.



Fig. 569

588. Direct vision spectrocope.—

A direct vision spectrocope is one in which the mean direction of the light is not altered. Prisms may be combined so as to get rid of the dispersion without entirely destroying the refraction (595); they may, conversely,

be combined so that the light is not refracted, but is decomposed and produces a spectrum. Combinations of prisms of this kind are used in what are called *direct vision spectroscopes*.

Fig. 570 represents the section of such an instrument in about $\frac{2}{3}$ the natural size. A system of two flint and three crown glass prisms is placed in a tube which moves in a second one; at the end of this is an aperture *o*, and inside

it a slit the width of which can by a special arrangement be regulated by simply turning a ring *r*. A small achromatic lens is introduced at *aa*, the principal focus of which is just outside the slit, so that the rays pass through the train of prisms, and the eye at *e* sees a virtual image of the slit opened out into a spectrum.



Fig. 570

Such combinations have the disadvantage of absorbing much light. On passing from one medium into another some light is always lost by reflection. This loss depends upon the difference between the refractive indices of the media. Wernicke has constructed a direct vision prism in which the loss of light is greatly reduced. It consists of two prisms of crown glass and glass plates as shown in fig. 571; the hollow space formed is filled with cinnamic ether, which, while it has but a slightly larger refractive index, has three or four times the dispersion of crown glass.

Such combinations have the disadvantage of absorbing much light.

On passing from one medium into another some light is always lost by reflection. This loss depends upon the difference between the refractive indices of the media. Wernicke has constructed a direct vision prism in which the loss of light is greatly reduced. It consists of two prisms of crown glass and glass plates as shown in fig. 571; the hollow space formed is filled with cinnamic ether, which, while it has but a slightly larger refractive index, has three or four times the dispersion of crown glass.

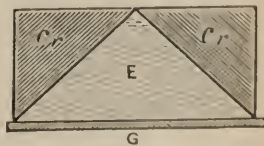

Fig. 571

the loss of light is greatly reduced. It consists of two prisms of crown glass and glass plates as shown in fig. 571; the hollow space formed is filled with cinnamic ether, which, while it has but a slightly larger refractive index, has three or four times the dispersion of crown glass.

The *reversion spectroscope* contains two equal systems of direct vision prisms arranged close to each other, but *reversed*, so that two spectra are obtained with the colours in opposite order. By suitable micrometric movement of a split lens, the two spectra may be moved apart or nearer each other. Hence it is possible to bring any two identical lines so that they are in the same vertical line. If now the position of these lines in the spectrum is altered, the displacement will take place in the opposite direction in the two spectra, and will therefore be twice as distinct.

589. **Experiments with the spectroscope.**—There are three chief types of spectra: the *continuous* spectra, or those furnished by incandescent solids and liquids (fig. 1, Plate 1.); the *band* or *line* spectrum, consisting of a number of bright lines or bands, produced by incandescent gases or vapours; and *absorption* spectra, such as those furnished by the sun or fixed stars. Bodies at a red heat give only a short spectrum, extending at most to the orange; as the temperature gradually rises, yellow, green, blue, and violet successively appear, while the intensity of the lower colours increases. The coloured plate at the beginning shows certain spectra observed by means of the spectroscope. No. 1 represents the continuous spectrum.

No. 2 shows the spectrum of sodium. The spectrum contains neither red, orange, green, blue, nor violet. It is marked by a very brilliant yellow ray in exactly the same position as Fraunhofer's dark line D. Of all metals sodium is that which possesses the greatest spectral sensibility. In fact, it has been ascertained that one two-hundred-millionth of a grain of sodium is enough to cause the appearance of the yellow line. Consequently it is difficult to avoid the occurrence of this line. A very little dust in the apartment is enough to produce it—a circumstance which shows how abundantly sodium is distributed.

No. 3 is the spectrum of *lithium*. It is characterised by a well-marked line in the red called Li α and by the feebler orange line Li β .

Nos. 4 and 5 show the spectra of *cæsium* and *rubidium*, metals discovered by Bunsen and Kirchhoff by means of spectrum analysis. The former is distinguished by two blue lines, Cs α and Cs β ; the latter by two very brilliant dark red lines, Rb γ and Rb δ , and by two less intense violet lines, Rb α and Rb β . A third metal, *thallium*, has been discovered by the same method by Sir W. Crookes in England, and independently by Lamy in France. Thallium is characterised by a single green line. Subsequently to this Richter and Reich discovered in association with zinc a new metal, which they call *indium* from a couple of characteristic lines which it forms in the indigo; Boisbaudran discovered a new metal, which he called *gallium*, associated with zinc in very minute quantities; and in more recent times, *germanium*, *scandium*, *samarium*, and *helium* have been discovered.

The extreme delicacy of the spectrum reactions, and the ease with which they are produced, constitute them a most valuable help in the qualitative analysis of the alkalis and alkaline earths. It is sufficient to place a small portion of the substance under examination on platinum wire as represented in fig. 566, and compare the spectrum thus obtained either directly with that of another substance, or with the charts in which the positions of the lines produced by the various metals are laid down.

With other metals the production of their spectra is more difficult, especially in the case of some of their compounds. The heat of a Bunsen's burner is insufficient to vaporise the metals, and a higher temperature must be used. This is obtained by taking electric sparks between wires consisting of the metal whose spectrum is required, and the electric sparks are most conveniently obtained by means of Ruhmkorff's coil. In order to investigate solutions of salts the apparatus shown in fig. 572 is used. A platinum wire is fixed in the bottom, and over one end a small conical glass tube D is placed; only so much solution is poured in that by capillary action it just rises to the top of D. Another glass tube, in which a platinum wire is fused, is fixed in the cork C, and its free end can be placed at any distance from D. Thus all the metals may be brought within the sphere of spectrum observation.

The dispersive power of the apparatus has great influence on the nature of the spectrum; while an apparatus with one prism only gives in a sodium flame the well-known yellow line, an apparatus with more prisms resolves it into two or three lines.

It has been observed that the character of the spectrum changes with the temperature; thus chloride of lithium in the flame of a Bunsen's burner gives a single intense peach-coloured line; in a hotter flame, as that of hydrogen, it gives an additional orange line; while in the oxyhydrogen jet or the electric arc a broad brilliant blue band comes out in addition. The sodium spectrum produced by a Bunsen's burner consists of a single yellow line; if, by the addition of oxygen, the heat is gradually increased, more bright lines appear; and with the aid of the oxyhydrogen flame the spectrum is continuous. Sometimes also, in addition to the appearance of new lines, an increase in temperature resolves those bands which exist into a number of fine lines, which in some cases are more and in some less refrangible than the bands from which they are formed. It may be supposed that the glowing vapour formed at the low temperature consists of the oxide of some difficultly reducible metal, whereas at the enormously high temperature of the spark these compounds are decomposed, and the true bright lines of the metal are formed.

The delicacy of the reaction increases very considerably with the temperature. With the exception of the alkalis, it is from 40 to 400 times greater at the temperature of the electric spark than at that of Bunsen's burner.

The spectra of the permanent gases are best obtained by taking the electric spark of a Ruhmkorff's coil, or Holtz's machine, through glass tubes of a special construction, consisting of two wide portions connected by a capillary tube (fig. 573), which in the wider parts are provided with electrodes of platinum or aluminium; they are filled with the gas in question in a state of great attenuation, and are usually known as *Geissler's tubes*; if the spark is passed through hydrogen, the light emitted is bright red, and the spectrum consists of three lines, one in the red and one in the blue, coinciding with Fraunhofer's lines C and F, and the third in the more refrangible part of the blue near the Fraunhofer line G (Frontispiece, No. 7). No. 6 represents

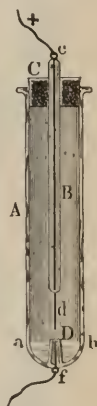

Fig. 572

the spectrum of oxygen. No. 8 is the spectrum of nitrogen. The light of this gas in a Geissler's tube is purple, and the spectrum very complicated.

If the electric discharge takes place through a compound gas or vapour, the spectra are those of the elementary constituents of the gas. It seems as if, at very intense temperatures, chemical combination were impossible, and oxygen and hydrogen, chlorine and the metals, could coexist in a separate form, as though mechanically mixed with each other.

The nature of the spectra of the elementary gases is very materially influenced by alterations of temperature and pressure. Wüllner made a series of very accurate observations on the gases oxygen, hydrogen, and nitrogen, at widely different temperatures and pressures. At the lowest pressure of less than 1 millimetre, the spectrum of hydrogen was found to be green, and consisting of six splendid groups of lines, which at a higher pressure than 1 millimetre changed to continuous bands; at 2 to 3 millimetres the spectrum consisted of the often-mentioned three lines, which did not disappear under a higher pressure, but gradually became less brilliant as the continuous spectrum increased in extent and lustre. From this point the light, and therefore the spectrum, became feebler. Using a larger apparatus, the band spectrum appeared only under a higher pressure; at the highest pressure of 2000 millimetres it gave place to the continuous spectrum, since the bright lines continually extended and ultimately merged into each other.

590. Explanation of the dark lines of the solar spectrum.—

It has been already seen that incandescent sodium vapour gives a bright yellow line corresponding to the dark line D of the solar spectrum. Kirchhoff found that, when the brilliant light produced by incandescent lime passes through a flame coloured by sodium in the usual manner, a spectrum is produced in which is a dark line coinciding with the dark line D of the solar spectrum; what would have been a bright yellow line becomes a dark line when formed on the background of the spectrum of the limelight. By allowing in a similar manner the limelight to traverse vapours of potassium, barium, strontium, &c., the bright lines which they would have formed were found to be converted into dark lines: such spectra are called *absorption spectra*.



Fig. 573

It appears, then, that the vapour of sodium has the power of absorbing rays of the same refrangibility as those which it emits. And the same is true of the vapours of potassium, barium, strontium, &c. This absorptive power is by no means an isolated phenomenon. These substances share it, for example, with the vapour of nitrous acid, which Brewster found to possess the following property:—when a tube filled with this vapour is placed in the path of the light either of the sun or of a gas flame, and the light is subsequently decomposed by a prism, a spectrum is produced which is full of dark lines (No. 9, Plate I.); and Miller showed that iodine and bromine vapour produced analogous effects.

Hence the origin of the above phenomenon is, doubtless, the absorption

by the sodium vapour of rays of the same kind—that is, having the same refrangibility—as those which it has itself the power of emitting. Other rays it allows to pass unchanged, but these it either totally or in great part suppresses. Thus the particular parts in the spectrum which these rays occupy are illuminated only by the feebly luminous sodium flame, and accordingly appear dark by contrast with the other portions of the spectrum which receive light from the powerful flame behind.

By replacing one of the flames G and H (fig. 568) by a pencil of sunlight reflected from a heliostat, Kirchhoff ascertained by direct comparison that the bright lines which characterise iron correspond to dark lines in the solar spectrum. He also found the same to be the case with sodium, magnesium, calcium, nickel, and some other metals.

This reversal of the sodium light may be produced even without a prism by an apparatus devised by Bunsen, and shown in fig. 574. It consists of a Woolf's bottle in which a small quantity of zinc, dilute sulphuric acid, and common salt are placed so that hydrogen is slowly liberated, charged with particles of sodium chloride, or, better, bromide. Through the india-rubber tube L ordinary coal gas is admitted, and issues through the tubes R and R'. On each of these tubes is a metal burner. The gas burns at the top A with a broad flat flame, C; the burner B is cylindrical, and over it is placed a conical mantle closed at the top with wire gauze. In this way a small yellow flame is produced. On looking through this against the wide flame, the former appears dark, as if smoky on a light background. The light of the posterior and far brighter flame is absorbed by the front and cooler one, and replaced by light of less intensity, which thus appears dark by contrast.

From such observations we may draw important conclusions with respect to the constitution of the sun. Since the solar spectrum has dark lines where sodium, iron, &c., give bright ones (No. 11, Plate I.), it is assumed that around the solid, or more probably liquid, body of the sun which throws out the light, there exists a vaporous envelope which, like the sodium flame in the experiment described above, absorbs certain rays, namely, those which the envelope itself emits. Hence those parts of the spectrum which, but for this absorption, would have been illuminated by these particular rays, appear feebly luminous in comparison with the other parts, since they are illuminated only by the light emitted by the envelope, and not by the solar nucleus; and we are at the same time led to conclude that in this vapour there exist the metals sodium, iron, &c.

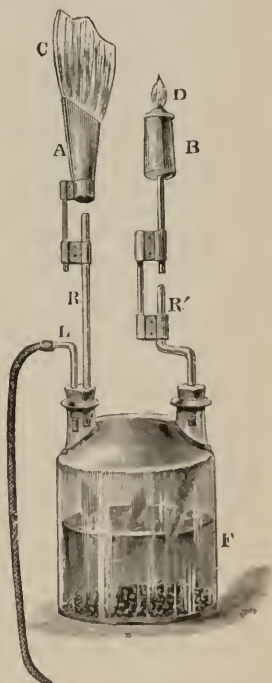

Fig. 574

Huggins and Miller applied spectrum analysis to the investigation of the heavenly bodies. The spectra of the moon and planets, whose light is reflected from the sun, give the same lines as those of the sun. Uranus proves an exception to this, and is probably still in a self-luminous condition. The spectra of the fixed stars contain, however, dark lines differing from the solar lines, and from one another. Four distinct types of spectra were distinguished by Secchi. The first embraces the white stars, and includes the well-known Sirius and α Lyræ. Their spectra (No. 12, Plate I.) usually contain a number of very fine lines, and always contain four broad dark lines which coincide with the bright lines of hydrogen. Out of 346 stars 164 were found to belong to this group. The second group embraces those having spectra intersected by numerous fine lines like those of our sun. About 140 stars, among them Pollux, Capella, ϕ Aquilæ, belong to this group. The third group embraces the red and orange stars, such as α Orionis, β Pegasi; the spectra of these (Nos. 13, 14, Plate I.) are divided into eight or ten parallel columnar clusters of dark and bright bands increasing in intensity to the red. Group four is made up of small red stars with spectra constructed of three bright zones increasing in intensity towards the violet. It would thus appear that these fixed stars, while differing from one another in the matter of which they are composed, are constructed on the same general plan as our sun. Huggins has observed a striking difference in the spectra of the nebulæ; where they can at all be observed they are found to consist generally of bright lines, like the spectra of the ignited gases, instead of, like the spectra of the sun and stars, consisting of a bright ground intersected by dark lines. It is hence probable that the nebulæ are masses of glowing gas, and do not consist, like the sun and stars, of a photosphere surrounded by a gaseous atmosphere.

We can apply the reasoning of Doppler's principle (233) to the case of light. When a source of light is approaching the earth, the eye receives a greater number of waves in a given time than when there is no relative motion, and the refrangibility is thus apparently greater; as it moves away the opposite is the case, the waves are longer. Hence, on the approach of a body yielding yellow light, for instance, the bright band D will be displaced towards the violet end of the spectrum, and as it recedes, towards the red end. This will also be the case with the corresponding dark line, proving that the whole medium is moved at the same time. Accordingly, by observing the displacement of particular lines, conclusions may be drawn as to the motion in the line of sight of what are called the fixed stars. Thus, from careful observation of the displacement of the F line in Sirius, Huggins has inferred that it is moving away from the earth with a velocity of 20 miles per second, while Arcturus is found to be approaching us at the rate of 50 miles per second.

One of the most interesting triumphs of spectrum analysis has been the discovery of the true nature of the *protuberances* which appear during a solar eclipse as mountains or cloud-shaped luminous objects varying in size and surrounding the moon's disc.

During the eclipse of 1868 it had been ascertained by Janssen that protuberances emitted certain bright lines coinciding with those of hydrogen. They have, however, been fully understood only since Lockyer and Janssen

discovered a method of investigating them at any time. The principle of this method is as follows :—When a line of light admitted through a slit is decomposed by a prism, the length of the spectrum may be increased by passing it through two or more prisms ; as the quantity of light is the same, it is clear that the intensity of the spectrum will be diminished. This is the case with the ordinary sources of light, such as the sun ; if the light is homogeneous, it will be merely deviated, and not reduced in intensity, by passage through the prisms. And if the source of light emits light of both kinds, the image of the slit, due to light of a definite refrangibility which the mixture may contain, will stand out, by its superior intensity, on the weaker ground of the continuous spectrum. This is the case with the spectrum of the protuberances. Viewed through an ordinary spectroscope, the light they emit is overshadowed by that of the sun ; but by using prisms of great dispersive power the sun's light becomes weakened, and the spectrum of the protuberances may be observed. Lockyer's researches leave no doubt that they are ignited masses of gas, principally hydrogen. By altering the position of the slit a series of sections of the prominences is obtained, by collating which the form of the prominence may be inferred. They are thus found to enclose the sun usually to a depth of about 5000 miles, but sometimes in enormous local accumulations, which reach the height of 70,000 miles. Lockyer has not merely examined these phenomena right on the edge of the sun, but he has been able to observe them on the disc itself. He has shown that some of these protuberances are the results of sudden outbursts or storms, which move with the enormous velocity of 120 miles in a second ; and, by reasoning as above, the direction of this motion has been determined.

For a fuller account of this branch of physics, which is incompatible with the limits of this work, the reader is referred to special works.

591. **Uses of the spectroscope.**—When a liquid placed in a glass tube or in a suitable glass cell is interposed between a source of light and the slit of the spectroscope, the spectrum observed on looking through the telescope will in many cases be found to be traversed by dark bands. It is called an *absorption spectrum*. No. 10, Plate I., represents the appearance of the spectrum when a solution of *chlorophyl*, the green colouring matter of plants, is thus interposed. In the red, the yellow, and the violet parts, dark bands are formed, and the blue gives way to a reddish shimmer. If, instead of chlorophyl, arterial blood greatly diluted is used, the red of the spectrum appears brighter, but green and violet are nearly extinguished. As these bands thus differ in different liquids as regards position, breadth, and intensity, in many cases they afford the most suitable means of identifying bodies. Sorby and Browning devised a combination of the microscope and spectroscope called the *microspectroscope*, which renders it possible to examine even very minute traces of substances.

This application of the spectroscope has been very useful in investigating substances which have special importance in physiology and pathology ; thus in examining normal and diseased blood, and in ascertaining the rate at which certain substances pass into the various fluids of the system. The characteristic absorption bands which certain liquids, such as wine, beer, &c., present in their normal state, compared with those yielded by

adulterated substances, furnish a delicate and certain means of detecting the latter.

Thus the adulteration of claret with the juice of elderberries is detected by the appearance of faint bands near line D, which are not seen with pure red wine. The colouring matter of malt and hops is quite distinct from that of many other substances with which it is alleged to be adulterated. An alkaline solution of blood to which ammonium sulphide is added gives two very powerful absorption bands between D and E, and between E and b ; this is the most valuable test for toxicological cases. Blood charged with carbonic oxide is unchanged on the addition of ammonium sulphide, and thus poisoning by carbonic oxide can be detected. So, too, the appearance of the characteristic bands of gall in blood, and of albumen in urine, are indications of jaundice and of Bright's disease respectively.

Suppose the slit of the spectroscope to be divided into two halves, S_1 and S_2 (fig. 575), the aperture of each of which can be varied to any measured

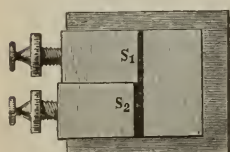

Fig. 575

extent by means of micrometric screws. If then a layer of a substance of known thickness is placed in front of the slit S_2 for instance, and the spectrum of a particular portion be observed, while unabsorbed light passes through S_1 , there will be a difference between the luminosities of the two parts of the spectrum; but by regulating the width of the slit they may be made the same. The luminosities will then be inversely as the width of the slit.

That is, if the width of each was originally 1, and the uncovered slit had to be narrowed to 0.4, the intensity of the light transmitted through the screen would only be 0.4 of the incident. Vierordt has based on this a method of quantitative spectrum analysis; thus if the absorption produced by a definite thickness of a solution of given strength is known, the relative concentration of any other solution of the same substance for the same thickness may be determined.

592. **Abnormal or anomalous dispersion.**—A remarkable exception to the ordinary law of dispersion was discovered by Christiansen, and subsequently confirmed and extended by Soret and Kundt—that the solutions of certain substances, such as indigo and potassium permanganate, give spectra in which

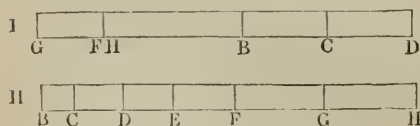

Fig. 576

the *order* of the colours is not the same as in the prismatic spectrum. Thus, when a hollow glass prism is filled with an alcoholic solution of fuchsine, the order of the colours in the spectrum which it yields is as follows. Violet is *least* refracted,

then red, and then yellow, which is *most* refracted. If we imagine that the central green of an ordinary spectrum is removed, and then the position of the rest is inverted, we get an idea of the abnormal spectrum of fuchsine. This will be seen from fig. 576, in which I represents the position of Fraunhofer's lines in the anomalous dispersion of fuchsine, while II represents the position in the normal spectrum. Kundt examined a great number of

substances in this direction, mostly the colours derived from aniline, and found that anomalous dispersion is exhibited by all substances with *surface colour*. These bodies have the peculiarity that when viewed in diffused light they exhibit a colour complementary to that which they transmit. Thus a thin flake of fuchsine appears green in diffused, but red in transmitted light. Metallic gold appears green in transmitted and reddish yellow by reflected light.

The substances in solution are examined by placing them in hollow glass prisms; if the solutions are weak, the abnormal dispersion of the substance is concealed by that of the solvent, while stronger solutions absorb so much light as to be almost opaque, and prisms of very small refracting angle have to be used. Soret gets rid of this difficulty by immersing the prism containing the solution in glass vessels with parallel sides filled with the solvent. The dispersion due to the solvent is thereby eliminated, and only that of the substance comes into play. Cyanine gives a well-marked abnormal spectrum, the order of the colours being the following: green, light blue, dark blue, a dark space, red, and traces of orange, the green being the colour which is least refracted. Anomalous dispersion is met with in gases which have marked absorption bands; thus in iodine for red light $n = 1.00205$, and for violet $n = 1.00192$.

The same explanation cannot be given of this as of the ordinary colour of bodies (580), but the phenomenon must be ascribed to the fact that the bodies in question totally reflect light of certain wave-lengths (651) at almost all incidences, and that these colours are reflected on the surface. Hence it follows that the colour of these bodies in diffused light must be almost complementary to the transmitted light—a prevision which experiment confirms.

593. **Fluorescence.**—Stokes made the remarkable discovery that in certain circumstances the rays of light are capable of undergoing a change of refrangibility. The discovery originated in the study of a phenomenon observed by Brewster, and by Herschel, that some varieties of flourspar, and also the solutions of certain substances, when looked at by transmitted light appear colourless, but when viewed in reflected light present a bluish appearance. Stokes has found that this property, which he calls *fluorescence* from having been observed in flourspar, is characteristic of a large number of bodies.

If by means of a lens of long focus, preferably of quartz, a beam of the sun's rays is focused on a solution of quinine sulphate



Fig. 577

contained in a glass trough, a beautiful cerulean blue cone of light (fig. 577) is formed, which is much the brightest on the surface, and the intensity of which rapidly diminishes as it penetrates the liquid.

It thus appears that fluorescence is due to an absorption of certain rays; rays of light which have passed through a sufficient thickness of a fluorescent substance lose thereby the power of exciting fluorescence when they are passed through a second layer of the same substance; thus a test tube

containing a fluorescent liquid is brightly luminous when exposed to the sun's rays, but loses this lustre at once when it is dipped in a trough of the same liquid, on the front of which the sun's rays fall. The same conclusion also is derived from a comparison of the absorption spectrum of a fluorescent substance with the appearance presented by this substance when the spectrum falls on it. Where the fluorescence begins there also begins the absorption, and to a maximum of absorption corresponds a maximum of fluorescence.

The phenomenon is seen when a solution of quinine sulphate, contained in a trough with parallel sides, is placed in different positions in the solar spectrum. No change is observed in the less refrangible part of the spectrum, but from a point about halfway between the lines G and H (coloured Plate) to some distance beyond the extreme range of the violet, rays of a beautiful sky-blue colour are seen to proceed. These invisible ultra-violet rays also become visible when the spectrum is allowed to fall on paper impregnated with a solution of *æsculine* (a substance extracted from horse-chestnut), an alcoholic solution of stramonium, or a plate of *canary glass* (which is coloured by means of a salt of uranium). If light is allowed to fall on paper impregnated with barium platinomanganide, a beautiful green fluorescence is observed.

If a few drops of a strong solution of *fluoresceine* in soda fall into a large beaker of water on the front of which the sun's rays fall, beautiful fluorescent clouds are first produced, and on shaking the liquid the whole vessel fluoresces with a bright green light.

This change arises from a diminution in the refrangibility of those rays outside the violet, which are ordinarily too refrangible to affect the eye.

Glass absorbs many of these more refrangible rays, which is not the case nearly to the same extent with quartz. When a prism and trough formed of quartz are used, and the spectrum is received on a sheet of paper on which a wash of solution of quinine sulphate has been made, two juxtaposed spectra can be obtained. That which is on the part coated with quinine sulphate extends beyond the line H to an extent equal to that of the visible spectrum. In the spectrum, thus made visible, dark lines may be seen analogous to those in the ordinary spectrum.

The phenomena may be observed without the use of a prism. When an aperture in a dark room is closed by means of a piece of blue glass, and the light is allowed to fall upon a piece of canary glass, it instantly appears self-luminous from the emission of the altered rays. If a test tube is half filled with a solution of quinine sulphate, and on it is poured a freshly prepared solution of chlorophyl in ether, the two layers appear colourless and green respectively in transmitted, and sky-blue and blood-red in reflected light.

In most cases it is the violet and ultra-violet rays which undergo an alteration of refrangibility, but the phenomenon is not confined to them. A decoction of madder in alum gives yellow and violet light from about the line D to beyond the violet; an alcoholic solution of chlorophyl gives red light from the line B to the limit of the spectrum. In these cases the yellow, the green, and the blue rays experience increase of refrangibility; the change produces more highly refrangible rays. An exception to this rule is met with in the case of Magdala red. If on a solution of this substance

contained in a rectangular glass vessel a solar spectrum is allowed to fall, an orange-yellow fluorescence is found even in the red part of the spectrum.

The electric light gives a very remarkable spectrum. With quartz apparatus Stokes obtained a spectrum six or eight times as long as the ordinary one. Several flames of no great illuminating power emit very peculiar light. Characters traced on paper with solution of stramonium, which are almost invisible in daylight, appear instantaneously when illuminated by the flame of burning sulphur or of carbon bisulphide. Robinson found that the light of the aurora is peculiarly rich in rays of high refrangibility.

594. **Chromatic aberration.**—The various lenses hitherto described possess the inconvenience that, when at a certain distance from the eye, they give images with coloured edges. This defect, which is most observable in condensing lenses, is due to the unequal refrangibility of the simple colours (575), and is called *chromatic aberration*.

For since the amount by which a ray is bent in passing through a lens depends upon the refractive index of the glass, and the refractive index depends upon the refrangibility, being greatest for the violet and least for the red rays, it follows that a lens has a distinct focus for each colour. In condensing lenses, for example, the red rays, which are the least refrangible, form their focus at a point R on the axis of the lens (fig. 578); while the violet rays, which are most refrangible, coincide in the nearer point V. The foci of the orange, yellow, green, blue, and indigo are between these points. The chromatic aberration is more perceptible in proportion as the lenses are more convex, and as the point at which the rays are incident is farther from the axis; for then the deviation, and therefore the dispersion, are increased.

If a pencil of rays which has passed through a condensing lens is received on a screen placed at *mm* within the focal distance, a bright central part is seen with a red border; if it is placed at *ss*, the bright centre has a violet border.

The inequality in the refraction of the blue and red rays may be demonstrated by closing a small aperture, half with red and half with blue glass (fig. 579); on each half a black arrow is painted, and a lamp is placed behind it. By means of a lens of about 60 cm. focus an image is formed on a screen at a distance. If the screen is placed so that a sharp image is obtained of the black object on the blue ground, the outlines of the other are confused. To get a sharp image of the arrow on the red ground the screen must be moved farther away.

595. **Achromatism.**—By combining prisms which have different refracting angles and are formed of substances of unequal dispersive powers (577), white light may be refracted without being



Fig. 578



Fig. 579

dispersed. The same result is obtained by combining lenses of different substances, the curvatures of which are suitably combined. The images of objects viewed through such lenses do not appear coloured, and they are accordingly called *achromatic lenses*; *achromatism* being the term applied to the phenomenon of the refraction of light without dispersion.

By observing the phenomenon of the dispersion of colours in prisms of water, of oil of turpentine, and of crown glass, Newton was led to suppose that dispersion was proportional to refraction. He concluded that there could be no refraction without dispersion, and, therefore, that achromatism was impossible. Almost half a century elapsed before this was found to be incorrect. Hall, an English philosopher, in 1733, was the first to construct achromatic lenses, but he did not publish his discovery. It is to Dollond, an optician in London, that we owe the greatest improvement which has been made in optical instruments. He showed in 1757 that by combining two lenses of suitable curvatures—one a double convex crown glass lens, the other a concavo-convex lens of flint glass (fig. 581)—a lens is obtained which is virtually achromatic.

To explain this result, let two prisms, BFC and CDF, be joined and turned in a contrary direction, as shown in fig. 580. Let us suppose, in the first case, that both prisms are of the same material, but that the refracting angle of the second, CDF, is less than the refracting angle of the first;

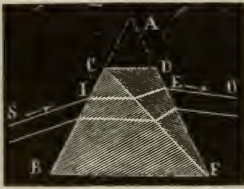

Fig. 580

that white light which traverses it will be not only refracted, but also decomposed. If, on the contrary, the first prism BCF were of crown glass, and the other CFD of flint glass, the dispersion might be destroyed without destroying the refraction. For, as flint glass is more dispersive than crown, and as the

dispersion produced by a prism diminishes with its refracting angle, it follows that by suitably lessening the refracting angle of the flint glass prism CFD, as compared with the refracting angle of the crown glass prism BCF, the dispersive power of these prisms may be equalised; and as, from their position, the dispersion takes place in a contrary direction, it is neutralised; that is, the emergent rays EO are parallel, and therefore give white light.

Nevertheless, the ratio of the angles BCF and CFD, which is suitable for the parallelism of the red rays and violet rays, is not so for the intermediate rays, and, consequently, only two of the rays of the spectrum can be exactly combined, and the achromatism is not quite perfect. To obtain perfect achromatism several prisms would be necessary, of unequally dispersive materials and with their angles suitably combined.



Fig. 581

The refraction is not destroyed at the same time as the dispersion; that could only happen if the refracting power of a body varied in the same ratio as its dispersive power, which is not the case. Consequently, the emergent ray EO is not exactly parallel to the incident ray, and there is a refraction without appreciable decomposition.

Achromatic lenses are made of two lenses of unequally dispersive

materials: one, A, of flint glass, is a diverging concavo-convex (fig. 581); the other, B, of crown glass, is double convex, and one of its faces may exactly coincide with the concave face of the first. As with prisms, several lenses would be necessary to obtain perfect achromatism; but for optical instruments two are sufficient, their curvatures being such as to combine not the extreme red and violet, but the blue and orange rays, while at the same time regard is had to the correction for spherical aberration. In Abbé's *apochromatic* lenses the crown glass is replaced by fluorspar, and thereby the chromatic as well as the spherical aberration is still further reduced.

CHAPTER V

OPTICAL INSTRUMENTS

596. **The different kinds of optical instruments.**—By the term *optical instrument* is meant any combination of lenses, prisms, mirrors, &c. Optical instruments may be divided into three classes, according to the ends they are intended to answer, viz. : i. *Microscopes*, which are designed to obtain a magnified image of any object whose real dimensions are too small to admit of its being seen distinctly by the naked eye. ii. *Telescopes*, by which very distant objects, whether celestial or terrestrial, may be observed. iii. *Instruments* designed to project on a screen a magnified or diminished image of any object which can thereby be either depicted or rendered visible to a crowd of spectators; such as the *camera lucida*, the *camera obscura*, *photographic apparatus*, the *magic lantern*, the *solar microscope*, the *photo-electric microscope*, &c.

MICROSCOPES

597. **The simple microscope.**—The *simple microscope*, or *magnifying glass*, is merely a convex lens of short focal length, by means of which we look at objects placed between the lens and its principal focus. Let AB (fig. 582) be the object to be observed, placed between the lens and its

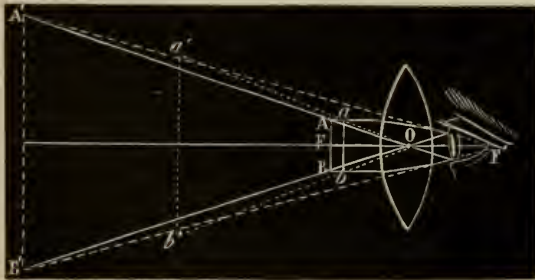

Fig. 582

principal focus, F. Draw the secondary axes AO and BO, and also from A and B rays parallel to the axis of the lens FO. Now these rays, on passing out of the lens, tend to pass through the second principal focus F'; consequently they are divergent with

reference to the secondary axes, and therefore, when produced, will cut those axes in A' and B' respectively. These points are the virtual foci of A and B respectively. The lens, therefore, produces at A'B' an erect and magnified virtual image of the object AB.

The position and magnitude of this image depend on the distance of the object from the focus. Thus, if AB is moved to ab , nearer the lens, the secondary axes will contain a greater angle, and the image will be formed at $a'b'$, and will be much smaller, and nearer the eye. On the other hand, if the object is moved farther from the lens, the angle between the secondary axes is diminished, and their intersection with the prolongation of the refracted rays taking place beyond $A'B'$, the image is formed farther from the lens, and is larger.

In a simple microscope both chromatic aberration and spherical aberration increase with the degree of magnification. We have already seen that the former can be corrected by using achromatic lenses (595), and the latter by using stops, which allow the passage of such rays only as are nearly parallel to the axis, the spherical aberration of



Fig. 583

these rays being nearly inappreciable. Spherical aberration may be still further corrected by using two plano-convex lenses, instead of one very convergent lens. When this is done, the plane face of each lens is turned towards the object (fig. 583). Although each lens is less convex than the simple lens which together they replace, yet their joint magnifying power is as great, and with a less amount of spherical aberration (570), since the first lens diverts towards the axis the rays which fall on the second lens. This combination of lenses is known as *Wollaston's doublet*.

There are many forms of the simple microscope. One of the best is that represented in fig. 584. On a horizontal support E , which can be raised and lowered by a rack K and pinion D , there is a black *eyepiece* m , in the centre of which is fitted a small convex lens or a Wollaston's doublet. Below this is the *stage* b , which is fixed, and on which the object is placed between glass plates. In order to illuminate the object powerfully, light is reflected from a concave glass mirror, M , so that the reflected rays fall upon the object. In using this microscope the eye is placed very near the lens, which is lowered or raised until the position is found at which the object appears in its greatest distinctness.



Fig. 584

598. **Conditions of distinctness of the images.**—In order that objects looked at through a microscope should be seen with distinctness, they must have a strong light thrown upon them, but this is by no means enough. It is necessary that the image be formed at a determinate distance from the eye. In fact, there is for each person a *distance of most distinct vision*—a distance, that is to say, at which an object must be placed from an observer's

eye in order to be seen with greatest distinctness. This distance is different for different observers, but ordinarily is between 10 and 12 inches. It is, therefore, at this distance from the eye that the image ought to be formed. Moreover, this is why each observer has to *focus* the instrument ; that is, to adapt the microscope to his own distance of most distinct vision. Focusing is effected by slightly varying the distance from the lens to the object, for we have seen above that a slight displacement of the object causes a great displacement of the image. With a common magnifying glass, such as is held in the hand, the adjustment is effected by merely moving it nearer to or farther from the object. In the microscope the adjustment is effected by means of a rack and pinion, which in the case of the instrument shown in fig. 584 moves the eyepiece. What has been said about focusing the microscope applies equally to telescopes. In the latter instrument the eyepiece is generally adjusted with respect to the image formed at the focus of the object-glass.

In respect of the distinctness of the image the general rules for convex lenses apply.

In order to lessen dispersion, lenses have been constructed of diamond, of ruby, and of other precious stones, which for a small amount of dispersion have a great degree of refrangibility. A drop of water or of Canada balsam in a small hole in a thin piece of wood or of metal acts as a microscope.

599. **Apparent magnitude of an object.**—The apparent magnitude or apparent diameter of a body is the angle it subtends at the eye of the



Fig. 585



Fig. 586

observer. Thus, if AB is the object, and O the observer's eye (figs. 585, 586), the apparent magnitude of the object is the angle AOB contained by two visual rays drawn from the centre of the pupil to the extremities of the object.

In the case of objects seen through optical instruments, the angles which they subtend are so small that the arcs which measure the angles do not differ sensibly from their tangents. The ratio of two such angles is

therefore the same as that of their tangents. Hence we deduce the two following principles :—

- i. *When the same object is seen at unequal distances, the apparent diameter varies inversely as the distance from the observer's eye.*
- ii. *In the case of two objects seen at the same distance, the ratio of the apparent diameters is the same as that of their absolute magnitudes.*

These principles may be proved as follows :—i. In fig. 585, let AB be the object in its first position, and *ab* the same object in its second position. For the sake of distinctness these are represented in such positions that the line OC passes at right angles through their middle points C and *c* respectively. It is, however, sufficient that *ab* and AB should be the bases of isosceles triangles having a common vertex at O. Now, by what has been said above, AB is virtually an arc of a circle described with centre O and radius OC ; likewise *ab* is virtually an arc of a circle whose centre is O and radius Oc. Therefore,

$$AOB : aOb = \frac{AB}{OC} : \frac{ab}{Oc} = \frac{r}{OC} : \frac{r}{Oc}$$

Therefore, AOB varies inversely as OC.

ii. Let AB and A'B' be two objects placed at the same perpendicular distance, OC, from the eye, O, of the observer (fig. 586). Then they are virtually arcs of a circle whose centre is O and radius OC. Therefore,

$$AOB : A'OB' = \frac{AB}{OC} : \frac{A'B'}{OC} = AB : A'B'$$

a proportion which expresses the second principle.

600. **Measure of magnification.**—In the simple microscope the measure of the magnification produced is the ratio of the apparent diameter of the image to that of the object, both being at the distance of most distinct vision. The same rule holds good for other microscopes. It is, however, important to obtain an expression for the magnification depending on data that are of easier determination.

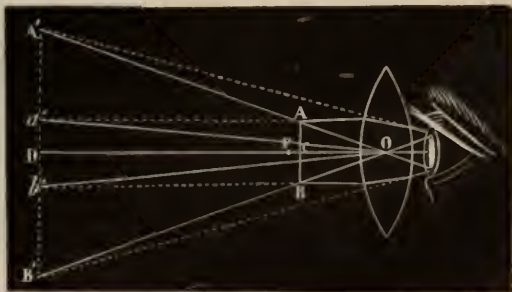

Fig. 587

In fig. 587, let AB be the object, and A'B' its image formed at the distance of most distinct vision. Let *a'b'* be the projection of AB on A'B'. Then, since the eye is very near the glass, the magnification equals $\frac{A'OB'}{a'Ob'}$ or $\frac{A'B'}{a'b'}$; that is, $\frac{A'B'}{AB}$. But since the triangles A'OB' and AOB are similar, A'B' : AB = DO : CO. Now DO is the distance of most distinct vision, and CO is very nearly equal to FO, the focal length of the lens. Therefore, the magnification equals the ratio of the

distance of most distinct vision to the focal length of the lens. Hence we conclude that the magnification is greater, 1st, as the focal length of the lens is smaller—in other words, as the lens is more convergent; 2ndly, as the observer's distance of most distinct vision is greater.

A simpler and more general definition of the measure of magnification may be stated thus: Let a be the angular magnitude of the object as seen by the naked eye, β the angular magnitude of the image, whether real or virtual, actually present to the eye, then the magnification is $\beta \div a$. This rule applies to telescopes.

By changing the lens the magnification may be increased, but only within certain limits if we wish to obtain a distinct image. By means of a simple microscope distinct magnification may be obtained up to 120 diameters.

The magnification we have here considered is *linear* magnification. *Superficial* magnification equals the square of the *linear* magnification; for instance, the former will be 1600 when the latter is 40.

601. **Principle of the compound microscope.**—The compound microscope in its simplest form consists of two convex lenses: one, with a short focus, is called the *object-glass*, or *objective*, because it is turned towards the object; the other is less condensing, and is called the *power*, or *eyepiece*, because it is close to the observer's eye.

Fig. 588 represents the path of the luminous rays and the formation of the image in the simplest form of a compound microscope. An object AB being placed very near the principal focus F of the object-glass M, but a little farther from the glass, a real image, ab , inverted and magnified, is formed on the other side of the object-glass (567). Now the distance of the two lenses M and N is regulated so that the position of the image ab is between the eyepiece N and its focus F'' . From this it follows that for the eye at E, looking at the image through the eyepiece, this glass produces the

same effect as a simple microscope, and instead of this image ab , another image, $a'b'$, is seen, which is virtual, and still more magnified. This second image, although erect as regards the

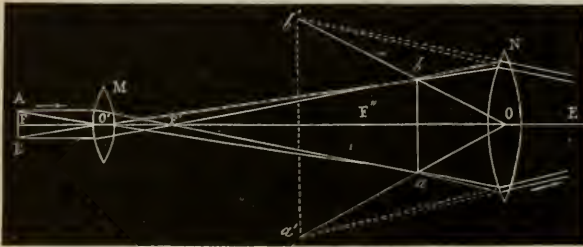

Fig. 588

first, is inverted in reference to the object. It may thus be said that the compound microscope is in effect a simple microscope applied not to the object but to its magnified image produced by the first lens.

602. **Compound microscope.**—The principle of the compound microscope has been already (601) explained; the principal accessories to the instrument remain to be described.

Fig. 589 represents a perspective view, and fig. 590 a section, of a compound microscope. The body of the microscope consists of a series of brass

tubes, DD', H, and I; in H is fitted the eyepiece O, and in the lower part of DD', the object-glass *o*. The tube I moves with gentle friction in the tube DD', which in turn can also be moved in a larger tube fixed in the ring E. This latter is attached to a piece BB', which, by means of a very fine screw worked by the milled head T, can be moved up and down an inner rod, not represented in the figure. The whole body of the microscope is raised and lowered with the piece BB', so that it can be placed near or far

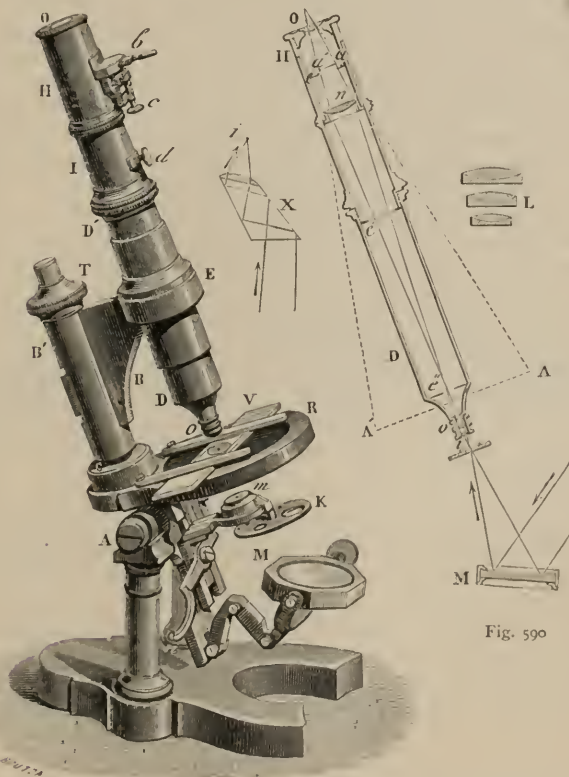

Fig. 589

Fig. 590

from the object to be examined. Moreover, all the pieces of the apparatus rest on a horizontal axis, A, with which they turn under so much friction as to remain fixed in any position in which they may be placed.

The object to be observed is placed between two glass plates, V, on a stage, R. This is perforated in the centre, so that light can be thrown upon the object by a concave reflecting glass mirror, M. The mirror is mounted on a jointed support so that it can be placed in any position whatever, so

as to reflect to the object either the diffused light of the sky, or that from a candle or lamp. Between the reflector and the stage is a *diaphragm* or *stop*, K, perforated by four holes of different sizes, any one of which can be placed over the perforation in the stage, and thus the light falling on the object may be regulated; the light can be further regulated by raising, by a lever *n*, the diaphragm K, which is movable in a slide. Above the diaphragm is a piece, *m*, to which can be attached either a very small stop, so that only very little light can reach the object, or a condensing lens, which illuminates it strongly, or an oblique prism, represented at X. The rays from the mirror undergo two total reflections in this prism, and emerge by a lenticular face that concentrates them on the object, but in an oblique direction, which in some microscopic observations is an advantage. Objects are generally so transparent that they can be lighted from below; but where, owing to their opacity, this is not possible, they are lighted from above by means of a condensing lens mounted on a jointed support, and so placed that they receive the diffused light of the atmosphere.

Fig. 590 shows the arrangement of the lenses and the path of the rays in the microscope. At *o* is the object-glass, consisting of three small achromatic lenses, represented on a larger scale at L, on the right of the figure. The eyepiece consists of two lenses, *n* and O, of which *n* is called the field-lens and O the eye-lens. The object being placed at *i*, a very little beyond the principal focus of the objective, the emerging rays fall upon the field-lens *n*, and are brought to a focus at *aa'*, where a real and magnified image of the object *i* is formed. The image is close to the focus of the eye-lens O, but a little nearer to the lens. Hence, on looking through this, which acts as a magnifier (567), we see at AA' a virtual and highly magnified image of *aa'*, and therefore of the object.

The position of the first image, *aa'*, is such that *its* image is seen by the observer distinctly and without effort. This result is obtained in moving, by the hand, the body DH of the microscope in the larger tube fixed to the ring E (fig. 589), until a tolerably distinct image is obtained; then turning the milled head T in one direction or the other, the piece BB', and with it the whole microscope, are moved until the image AA attains its greatest distinctness, which is the case when it is formed at the distance of most distinct vision: a distance which can always be ultimately obtained, for as the object-glass approaches or recedes from the object, the image *aa'* recedes from or approaches the eyepiece, and at the same time the image AA'.

This operation is called *focusing*. In the microscope, where the distance from the object-glass to the eyepiece is constant, it is effected by altering their distance from the object. In telescopes, where the objects are inaccessible, the focusing is effected by varying the distance between the eyepiece and the object-glass.

A microscope generally possesses numerous eyepieces and object-glasses, by means of which a great range of magnifying power is obtained. A lower magnifying power is also obtained by removing one or two of the lenses of the object-glass.

The above contains the essential features of the microscope; it is made in a great variety of forms, which differ mainly in the construction of the

stand, the arrangement of the lenses, and in the illumination. For descriptions of these the student is referred to special works on the microscope.

603. **Eyepieces.**—The eyepiece described in the last paragraph is known as Huyghens' or the negative eyepiece. It was devised by Huyghens to diminish spherical aberration, and was designed for the telescope. It consists of two plano-convex lenses made of the same glass (fig. 591) and placed with their convex sides towards the object. If the focal length of the eye-lens O' is f , that of the field-lens is $3f$, and the distance between them is $2f$. The bending necessary to bring the rays from the object into the eye is divided equally between the two lenses, and thus spherical aberration is diminished. The real image, A' , of the point a is formed halfway between the two lenses, and hence if any cross wires or micrometer scale is required in an instrument fitted with this eyepiece it must be placed in this position. It happens that the lenses of this eyepiece form an achromatic combination, though this fact was unknown to its inventor; it was pointed out by Boscovich. The arrangement is called a negative eyepiece because it cannot be used as a simple magnifier; this is clear from fig. 591, which shows that if parallel rays enter the eye they must proceed from a point between the two lenses, and hence that an object placed anywhere

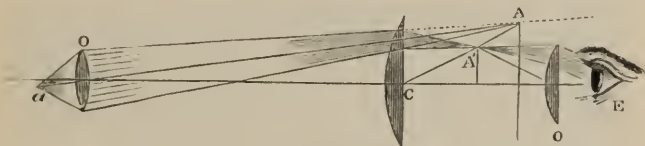

Fig. 591

outside C could not be seen distinctly by an eye at E . The negative eyepiece was first applied to microscopes by Campani, and is frequently known by his name.

The positive eyepiece, or Ramsden's, consists of two plano-convex lenses, of equal size and equal focal length, placed with their convex sides facing each other. The distance between them is two-thirds of the focal length of either. This eyepiece does not satisfy the condition of achromatism, though it is fairly achromatic. It is more frequently applied to telescopes than to microscopes.

In the case of the negative eyepiece the rays from the object-glass of the instrument, whether telescope or microscope, must *converge* upon the field-lens, and thus the object with which this eyepiece deals is a virtual object. In the case of the positive eyepiece, however, the rays from the object-glass must come to a focus *before* they reach the eyepiece, and thus the eyepiece deals with real objects or real images.

604. **Field of view.**—By the field of view of an optical instrument are meant all those points which are visible through the eyepiece. The advantage obtained by the use of an eyepiece in enlarging the field of view will be readily understood by an inspection of fig. 591. As before, O is the object-glass, C the field-lens, O' the eye-lens, and E the eye placed on the axis of the instrument. Let a be a point of the object; if

we suppose the field-lens removed, the pencil of rays from a would be brought to a focus at A , and none of them would fall on the eye-lens O' , or pass into the eye E . The point a is therefore beyond the field of view. But when the field-glass C is interposed, the pencil of rays is brought to a focus at A' , and emerges from O' into the eye. Consequently, a is now within the field of view. In this manner the substitution of an eyepiece for a single eye-lens enlarges the field of view.

605. Magnifying power. Micrometer.—The magnifying power of any optical instrument is the ratio of the magnitude of the image to the magnitude of the object. The magnifying power in a compound microscope is the product of the respective magnifying powers of the object-glass and of the eyepiece; that is, if the first of these magnifies 20 times, and the other 10, the total magnifying power is 200. The magnifying power depends on the greater or less convexity of the object-glass and of the eyepiece, as well as on the distance between these two glasses, together with the distance of the object from the object-glass. A magnifying power of 1500 and even upwards has been obtained; but the image then loses in sharpness what it gains in extent. To obtain precise and well-illuminated images, we must limit the magnifying power to 500 to 600 diameters, which gives a superficial enlargement 250,000 to 360,000 times that of the object.

The magnifying power is determined experimentally by means of the *glass micrometer*: this is a small glass plate, on which, by means of a diamond, a series of lines is drawn at a distance from each other of $\frac{1}{10}$ or $\frac{1}{100}$ of a millimetre. The micrometer is placed in front of the object-glass, and then, instead of viewing directly the rays emerging from the eyepiece O , they are received on a piece of glass A (fig. 592), inclined at an angle of 45° , and the eye is placed above so as to see the image of the micrometer lines formed by reflection, on a screen E , on which is a scale divided into millimetres.

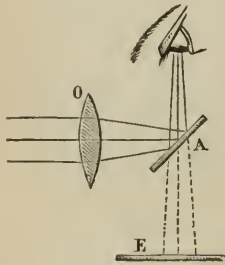

Fig. 592

By counting the number of divisions of the scale corresponding to a certain number of lines of the image, the magnifying power may be deduced. Thus, if the image occupies a space of 45 millimetres on the scale and contains 15 lines of the micrometer, the distances between which shall be assumed at $\frac{1}{100}$ millimetre, the absolute magnitude of the object will be $\frac{1}{100}$ millimetre; and as the image occupies a space of 45 millimetres, the magnification will be the quotient of 45 by $\frac{1}{100}$, or 300. The eye in this experiment ought to be at such a distance from the screen E that the screen is distinctly visible: this distance

varies with different observers, but is usually 10 to 12 inches. The magnifying power of the microscope can also be determined by means of the *camera lucida* (615); it is increased at the expense of brightness, definition, and field. Hence it is usual to have several eyepieces with each microscope so as to obtain greater definition of higher magnification.

Nobel's lines are frequently used as test objects; these are lines ruled on glass in series; in the first group the lines are at a distance of $\frac{1}{2000}$ of an inch from the middle of one line to the middle of the next; in the finest the

lines are at a distance of $\frac{1}{120000}$ of an inch. Other test objects are the scales of certain butterflies, and various kinds of diatoms.

When once the magnifying power is known, the absolute magnitude of objects placed under the microscope is easily deduced. For, as the magnifying power is the quotient of the size of the image by the size of the object, it follows that the size of the image divided by the magnifying power gives the size of the object: in this manner the diameters of all microscopic objects are determined.

TELESCOPES

606. **Astronomical telescope.**—The *astronomical telescope* is used for observing the heavenly bodies: like the microscope, it consists of a convex eyepiece and convex object-glass. The object-glass, M (fig. 593), forms between the eyepiece, N, and its principal focus an inverted image of the heavenly body; and this eyepiece, which acts as a magnifying glass, then gives a virtual and highly magnified image, $a'b'$, of the image ab . The astronomical telescope appears, therefore, analogous to the microscope; but the two

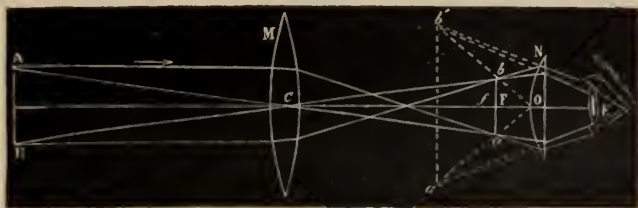

Fig. 593

instruments differ in this respect, that in the microscope, the object being very near the object-glass, the image is formed much beyond the principal focus, and is greatly magnified, so that both the object-glass and the eyepiece magnify; while in the astronomical telescope, the heavenly body being at a great distance, the incident rays are parallel, and the image formed in the principal focus of the object-glass is much smaller than the object. There is no magnification except by the eyepiece, and this ought, therefore, to be of very short focal length.

Fig. 594 shows an astronomical telescope mounted on its stand. Above it there is a small telescope which is called the *finder*. Telescopes with a large magnifying power are not convenient for finding a star, as they have but a small field of view: the position of the star is, accordingly, first sought by the finder, which has a much larger field of view—that is, takes in a far greater extent of the heavens; it is then viewed by means of the telescope.

The magnification (600) equals $\frac{a'O'b'}{ACB}$ (fig. 593); that is, it equals $\frac{bOC}{bCO}$ and therefore is approximately equal to $\frac{CF}{OF}$, F being the focus of the object-glass M, and being supposed very nearly to coincide with the focus of the eyepiece N; hence it may be concluded that the magnifying power is

greater in proportion as the object-glass is less convex, and the eyepiece more so.

When the telescope is used to make an accurate observation of the stars—for example, the zenith distance, or their passage over the meridian—a positive (Ramsden's) eyepiece is used and a *cross wire* is added. This consists of two very fine metal wires or spider threads stretched across a

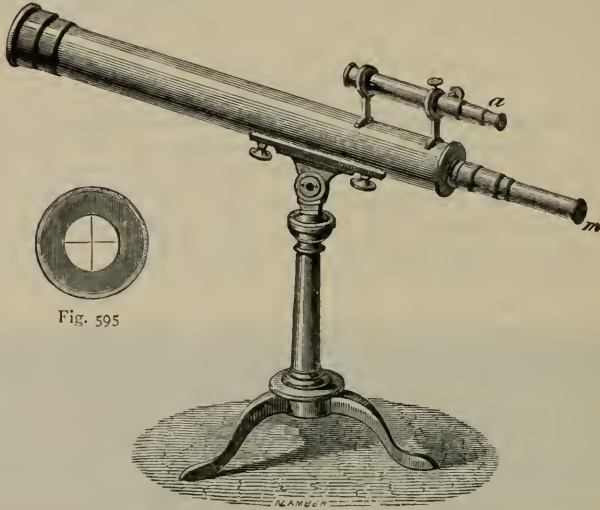

Fig. 595

Fig. 594

circular aperture in a small metal plate (fig. 595), their intersection being on the axis, or line of collimation, of the telescope. The cross wires are focused by moving the eyepiece with regard to them, and the distant object is then focused by moving the tube (by rack and pinion) containing the eyepiece and cross wires to or from the object-glass. The cross wires must be situated exactly where ba , the image of the observed object, is formed (fig. 593).

607. **Terrestrial telescope.**—The *terrestrial telescope* differs from the astronomical telescope in producing images in their right positions. This is



Fig. 596

effected by means of two convex lenses, P and Q (fig. 596), placed between the object-glass M and the eyepiece N (fig. 593). The object-glass being supposed to be on the left of fig. 596, an inverted and small image of a

distant object AB is formed at ba . The lenses P and Q are fixed in a tube which slides in the larger tube of the telescope, their distance apart being equal to the sum of their focal lengths, and their position is adjusted so that ba is at the principal focus of P . If aO is a secondary axis of this lens, all rays from a will, after refraction, be parallel to aO . These parallel rays, falling on the lens Q , converge after refraction to a' on the secondary axis $O'a'$. It is clear from the figure that if the lenses P and Q are exactly alike, the effect of their interposition will be to invert the image ba without altering its size. $a'b'$ is magnified by the eyepiece in the ordinary way. If the telescope is provided with cross wires they must be fixed in the plane of the image $a'b'$.

In order to determine directly the magnifying power of a telescope, when this is not great, a divided scale at a distance, or the tiles of a house may be viewed through the telescope with one eye and directly with the other. This with a little practice is not difficult. It is thus observed how many unmagnified divisions correspond to a single magnified one. Thus if two seen through the telescope appear like seven, the magnifying power is $3\frac{1}{2}$. Reading ordinary printing from a distance is an excellent means of testing and comparing telescopes.

The excellence of a telescope depends also on the sharpness of the images. To test this, various circular and angular figures are painted in black on a white ground, as shown in fig. 597 in about $\frac{1}{10}$ the full size. When these are looked at through the telescope at a distance of 80 or 100 paces, they should appear sharply defined, perfectly black, without distortion, and without coloured edges. The *penetration* or *penetrating power* of a telescope, by which stars are seen which are not visible to the naked eye, depends mainly on the aperture of the object-glass. Even with the strongest magnification the fixed stars appear as luminous points without apparent diameter.

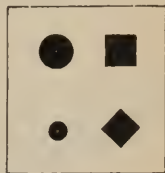

Fig. 597

608. **Galileo's telescope.**—*Galileo's telescope* is the simplest of all telescopes, for it consists of only two lenses; namely, an object-glass, M , and a diverging or double concave eyepiece, R (fig. 598), and it gives at once an erect image. *Opera-glasses* are constructed on this principle.

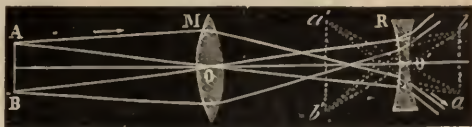

Fig. 598

If the object is represented by the right line AB , a real but inverted and smaller image would be formed at ba ; but these rays, falling on the concave lens R , are bent away from the principal axis and diverge.

The case in which a pencil of converging rays falls upon a concave lens has already been considered (56). If the middle point of the line ba coincides with the principal focus of the lens, the rays from A , which would (but for the presence of R) meet at a , emerge from the lens as a parallel beam, parallel to the secondary axis $O'a$. But if ba is a little nearer to the lens than its principal focus, the emergent rays are slightly divergent, and appear to an

eye placed close to R to come from a' ; similarly for the point b . Thus the eye sees an erect and magnified image at $a'b'$, which appears nearer because it is seen under an angle, $a'O'b'$, greater than the angle, AOB, under which the object is seen.

The magnifying power is equal to the ratio of the angle $a'O'b'$ to the angle AOB, and is usually from 2 to 4.

The distance of the eyepiece R from the image ab is very nearly equal to the focal length of this eyepiece ; it follows, therefore, that the distance between the two lenses is the difference between their focal lengths ; hence

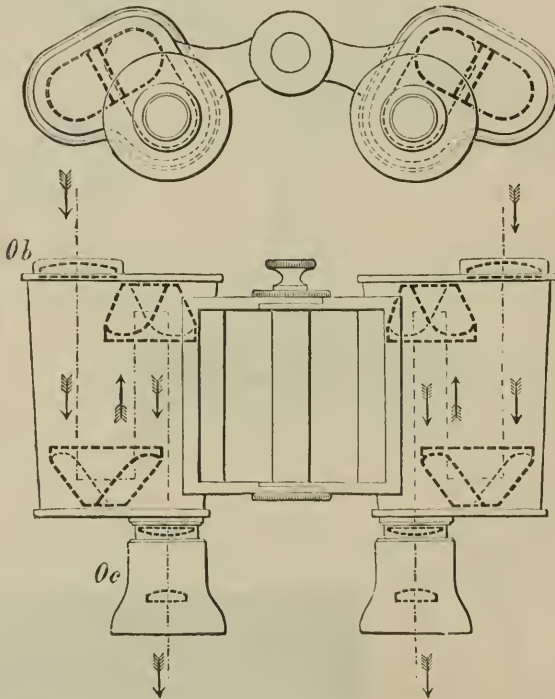

Fig. 598A

Galileo's telescope is very short and portable. It has the advantage of showing objects in their right position ; and, further, as it has only two lenses, it absorbs very little light : in consequence, however, of the divergence of the emergent rays, it has only a small field of view, and in using it the eye must be placed very near the eyepiece. The eyepiece can be moved to or from the object-glass, so that the image $a'b'$ is always formed at the distance of distinct vision.

The opera-glass is usually double, so as to produce an image in each eye, by which greater brightness is attained.

In the binocular field-glass each tube is in effect an astronomical

telescope, the eyepiece being, not a concave lens as in the opera-glass, but a combination of two convex lenses forming a positive eyepiece (603). In Zeiss's field-glass (fig. 598A) the effect of increased length, and therefore increased magnifying power, is obtained by the use of right-angled glass prisms. A pencil of light entering the object-glass (*Ob*) does not pass direct to the eyepiece, but falls normally on the hypotenuse face of a right-angled prism, undergoes two total internal reflections, and emerges parallel and opposite to its original direction. The rays are again twice reflected by another right-angled prism, fixed laterally near the object-glass, and finally pass into the eyepiece (*Oc*). The effective length of the telescope is thus nearly three times the actual length. A disadvantage of this type of telescope is the absorption of light by the glass prisms.

Some attribute the invention of telescopes to Roger Bacon in the thirteenth century; others to J. B. Porta at the end of the sixteenth; others, again, to a Dutchman, Jacques Metius, who, in 1609, accidentally found that by combining two glasses, one concave and the other convex, distant objects appeared nearer and much larger. Galileo's was the first telescope directed towards the heavens. By its means Galileo discovered the mountains of the moon, Jupiter's satellites, and the spots on the sun.

609. Reflecting telescopes.—

The telescopes previously described are *refracting* or *dioptric* telescopes. It is, however, only in recent times that it has been possible to construct achromatic lenses of large size; before this a concave metallic mirror was used instead of the object-glass. Telescopes of this kind are called *reflecting* or *catoptric* telescopes. The principal forms are those devised by Gregory, Newton, Herschel, and Cassegrain.

610 The Gregorian telescope.

Fig. 599 is a representation of Gregory's telescope; it is mounted on a stand, about which it is movable, and can be inclined at any angle. This mode of mounting is optional; it may be equatorially mounted. Fig. 600 gives a longitudinal section. It

consists of a long brass tube closed at one end by a concave metallic mirror, *M*, which is perforated in the centre by a round aperture through which rays reach the eye. There is a second concave metal mirror, *N*, near the end of the tube: it is somewhat larger than the central aperture in the large mirror, and its radius of curvature is much smaller than that of the large mirror. The axes of both mirrors coincide with the axis of the tube. As the centre of curvature of the large mirror is at *O*, and its principal focus at *ab*, rays such as *SA* emitted from a heavenly body are reflected



Fig. 599

from the mirror *M*, and form at *ab* an inverted and very small image of the heavenly body. The distance of the mirrors is so arranged that the position of this image is between the centre, *o*, and the focus, *f*, of the small mirror; hence the rays, after being reflected a second time from the mirror *N*, form at *a'b'* a magnified and inverted image of *ab*, and therefore in the true position of the heavenly body. This image is viewed through an eyepiece, *P*, which may be either simple or compound, its object being to magnify the image again, so that it is seen at *a''b''*.

As the objects viewed are not always at the same distance, the focus of the large mirror, and therefore that of the small one, vary in position;

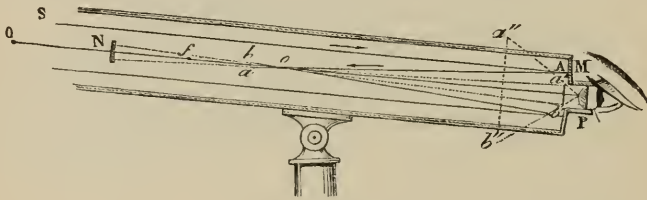

Fig. 600

and as the distance of distinct vision is not the same with all eyes, the image *a''b''* ought to be formed at different distances. The required adjustments may be obtained by bringing the small mirror nearer to or farther from the larger one; this is effected by means of a milled head, *A* (fig. 599), which turns a rod, and this by a screw moves a piece to which the mirror is fixed.

611. The Newtonian telescope.—This instrument does not differ much from that of Gregory; the large mirror is not perforated, and there is a small plane mirror inclined at an angle of 45° towards an eyepiece placed in the side of the telescope.

The difficulty of constructing metallic mirrors caused telescopes of Gregorian and Newtonian construction to fall into disuse. Of late, however, the process of silvering glass mirrors has been carried to a high state of perfection, and Foucault applied these mirrors to Newtonian telescopes with great success. His first mirror was only 4 inches in diameter, but he successively constructed mirrors of 8, 12, and 13 inches, and at the time of his death had completed one of 32 inches in diameter.

Fig. 602 represents a Newtonian telescope mounted on an equatorial stand, and fig. 601 gives a longitudinal section of it. This section shows how the luminous rays reflected from the parabolic mirror *M* meet a small rectangular prism, *m*, which replaces the inclined plane mirror used in the old form of Newtonian telescope. After undergoing a total reflection from *m*, the rays form at *a'b'* a very small image of the heavenly body. This image is viewed through a compound eyepiece placed on the side of the telescope, and magnifying from 50 to 800 times according to the size of the silvered mirror.

In reflectors the mirror acts as object-glass, but there is, of course, no chromatic aberration. The spherical aberration is corrected by the form

given to the reflector, which is paraboloidal, but slightly modified by trial to suit the eyepiece fitted to the telescope.

The mirror when once polished is immersed in a silvering liquid, which consists essentially of ammoniacal solution of silver nitrate, to which some

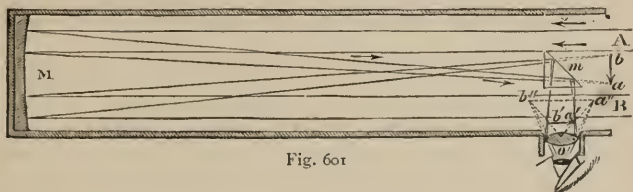

Fig. 601

reducing agent is added. When a polished glass surface is immersed in this solution, silver is deposited on the surface in the form of a brilliant metallic layer, which adheres so firmly that it can be polished with rouge

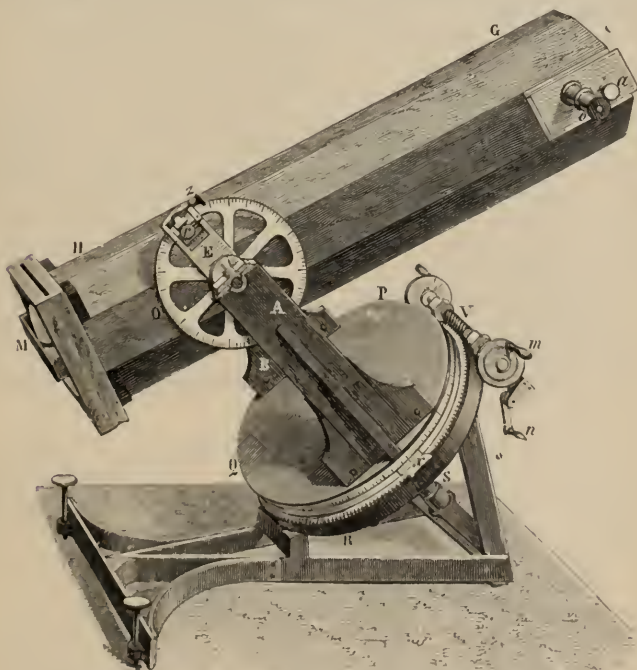

Fig. 602

in the usual manner. These new telescopes with glass mirrors have the advantage over the old ones that they give purer images; they weigh less and are much shorter, their focal distance being only about six times the diameter of the mirror.

These details known, the whole apparatus remains to be described. The body of the telescope (fig. 602) consists of an octagonal wooden tube. The end G is open; the mirror is at the other end. At a certain distance from this end two axles are fixed, which rest on bearings supported by two wooden uprights, A and B. These are themselves fixed to a table, PQ, which turns on a fixed plate, RS, placed exactly parallel to the Equator. On the circumference of the turning-table there is a brass circle divided into 360 degrees; and beneath it, but also fixed to the turning-table, there is a circular toothed wheel, in which an endless screw, V, works. By moving this in either direction by means of the handle *m*, the table PQ, and with it the telescope, can be turned. A vernier, *x*, fixed to the plate RS, gives fractions of a degree. On the axis of the motion of the telescope there is a graduated circle, O, which serves to measure the *declination* of the star, that is, its angular distance from the Equator; while the degrees traced round the plate RS serve to measure the *right ascension*, that is, the angle which the declination circle of the star makes with the declination circle passing through the first point of Aries.

In order to fix the telescope in declination, a brass plate, E, is fixed to the upright; it is provided with a clamp, in which the limb O works, and which can be screwed tight by means of a screw with a milled head *r*. On the side of the apparatus is the eyepiece *o*, which is mounted on a sliding copper plate, on which there is also the small prism *m*, represented in section in fig. 601. To bring the image to the right place, this plate may be moved by means of a rack and a milled head *a*. The handle *n* serves to *clamp* or *unclamp* the screw V. The drawing is one taken from a telescope the mirror of which is only $6\frac{1}{2}$ inches in diameter, and which gives a magnifying power of 150 to 200.

612. **The Herschelian telescope.**—Sir W. Herschel's telescope, which was for long the most celebrated instrument of modern times, was constructed on a method differing from those described. The mirror was so inclined (fig. 603) that the image of the star was formed at *ab* on the side of the telescope near the eyepiece *o*; hence it is termed the *front-view* telescope. As the rays in this telescope undergo only a single reflection, the loss of light is less than in either of the preceding cases, and the image is therefore

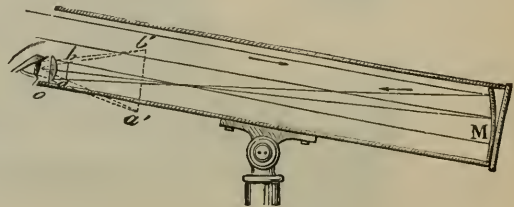

Fig. 603

brighter. The magnifying power is the quotient of the focal length of the mirror by the focal length of the eyepiece.

Herschel's great telescope was constructed in 1789; it was 40 feet in length, the great mirror was 50 inches in diameter. The quantity of light obtained by this instrument was so great as to enable its inventor to use magnifying powers far higher than anything which had hitherto been attempted.

Herschel's telescope has been exceeded by one constructed by the

late Earl of Rosse. This magnificent instrument has a focal length of 53 feet, the diameter of the speculum being 6 feet. It is at present used as a Newtonian telescope, but it can also be arranged as a front-view telescope.

613. **Notable telescopes.**—The largest refracting telescope ever constructed was erected in the Paris Exhibition of 1900. Its object-glass, which was made specially for photographic work, has a diameter of 125 cm., or 49·2 inches, and a focal length of 57 metres. It is an achromatic combination of two lenses, a convex lens of ground glass weighing 220 kilogrammes, and a concave lens of flint glass weighing 360 kilogrammes. The telescope tube is of steel 2 millimetres thick, and weighs 21,000 kilogrammes.

The instrument is not intended to be pointed at the sun or other heavenly body, but to be permanently fixed, with its axis horizontal, and the light to be examined is transmitted down the tube by a plane silvered glass reflector, called a heliostat (543), which is arranged by means of clock-work to follow the sun's motion. The diameter of the object-glasses of other large telescopes, and the observatories which possess them, are given below :—

	inches		inches
Yerkes	40	Leander, M'Cormick Obser-	
Lick	36	vatory, Virginia	26
Pulkowa	30	Greenwich	26
Nice	29·9	Newall's, Cambridge	25
Paris	28·9	Cape of Good Hope	24
Greenwich	28·0	Harvard	24
Vienna	27	Princeton, N.J., U.S.	23
Washington	26	Mount Etna	21

Large reflecting telescopes are not numerous. The following is a list of the largest, with the diameters of their reflectors :—

	ft. in.		ft. in.
Lord Rosse	6 0	Meudon	3 3
Dr. Common	5 0	Crossley (Lick)	3 0
Melbourne	4 0	South Kensington	3 0
Paris	4 0	Greenwich	2 6

INSTRUMENTS FOR FORMING PICTURES OF OBJECTS

614. **Camera obscura.**—The *camera obscura* (dark chamber) is, as its name implies, a closed space impervious to light. The principle of this apparatus is illustrated by fig. 604. The rays proceeding from an external object AB, and entering by the aperture O on one side, form on the side opposite an image of the object *ba* in its natural colours, but of reduced dimensions, and in an inverted position. See also article 515.

Porta, a Neapolitan physician, the inventor of this instrument, found that by fixing a double convex lens in the aperture, and receiving the image on a white screen, the image was much brighter and more definite.

615. **Camera lucida.**—The *camera lucida* is a small instrument depending on internal reflection, and serves for taking an outline of any object. It was invented by Wollaston in 1804. It consists of a small four-sided glass prism, of which fig. 605 gives a section perpendicular to the edges. A is a right angle, and C an angle of 135° ; the other angles, B and D, are $67\frac{1}{2}^\circ$. The prism rests on a stand, on which it can be raised or lowered, and turned



Fig. 604

more or less about an axis parallel to the prismatic edges. When the face AB is turned towards the object, the rays from the object fall nearly perpendicular on this face, pass into the prism without any appreciable refraction, and are totally reflected from BC, since the angle anL is $67\frac{1}{2}^\circ$, which is greater than the critical angle. The rays are again totally reflected from o , and emerge near the summit, D, in a direction almost perpendicular to the face DA, so that the eye which receives the rays sees at L' an image of the object L. If the outlines of the image are traced with a pencil, a very correct design is obtained; but unfortunately there is a great difficulty in seeing both the image and the point of the pencil, for

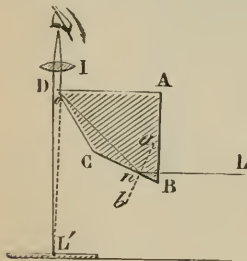

Fig. 605

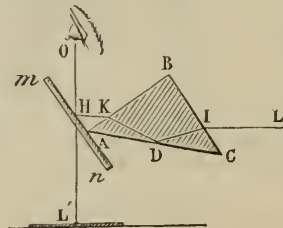

Fig. 606

In this case, however it is necessary to place the eye very near the edge of the prism, so that the aperture of the pupil is divided into two parts, one of which sees the image and the other the pencil.

Amici's camera lucida, represented in fig. 606, is preferable to that of Wollaston, inasmuch as it allows the eye to change its position to a considerable extent without ceasing to see the image and the pencil at the same time. It consists of a right-angled glass prism ABC having one of the faces enclosing the right angle turned towards the object to be depicted, while the other is perpendicular to an inclined plate of glass, mn . The rays LI, proceeding from the object, and entering the prism, are totally reflected from its base at D, and emerge in the direction KH. They are then partially reflected from the glass plate mn at H, and form an image of the object L, which is seen by the eye in the direction OL' . The eye at the same time sees through the glass the point of the pencil applied

the rays from the object give an image which is farther from the eye than the pencil. This is corrected by placing between the eye and prism a lens, I, which gives to the rays from the pencil and those from the object the same divergence.

to the paper, and thus the outline of the picture may be traced with great exactness.

616. **Magic lantern.**—This is an apparatus by which a magnified image of small objects may be projected on a white screen in a dark room. A typical form is the *sciopticon* (fig. 607). The box containing the source of light, one side of which is shown removed, is constructed of sheet iron; *e* is the flame of a lamp *V*, with two long flat wicks, fed by petroleum from the reservoir *B*. The box is airtight, and the chimney *F* producing a good draught, the air is

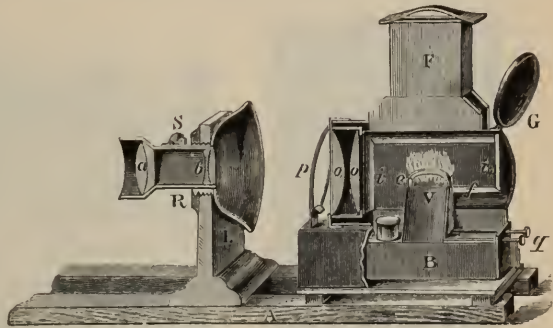

Fig. 607

compelled to pass through the wicks, by which smoke and smell are avoided, and a flame of high illuminating power is produced.

The ends of the box are closed by glass plates *i* and *i'*. *G* is a hinged door, and on its inside is a concave mirror; *o* and *o'* are two plano-convex lenses; *p* a spring clamp, in which is placed the transparent picture. The sliding piece supports the lens tube, in which are two achromatic lenses *a* and *b*, the fine adjustment of which is effected by the screw *S*.

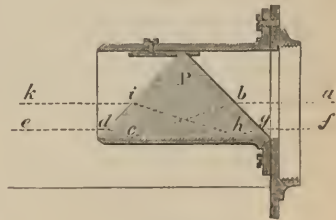

Fig. 608

The condensing lenses *o, o'* serve to illuminate strongly the object depicted on the slide which is placed in *p*, and a real, inverted and magnified image of the object is produced on a screen by the lens system *ab*. To erect this image a right-angled prism, *P* (fig. 608), is fixed in front of the lens tube, with its hypotenuse horizontal. The parallel rays falling on the prism are inverted in consequence of refraction at the sides and total reflection from the hypotenuse surface, so that an upright position is obtained instead of a reverse one. The dotted lines *abcde* and *fghik* give the paths of two rays.

The apparatus can be used for projecting on a screen not only horizontal images, such as those of magnetic curves, but also simple physical experiments, such as the expansion of a liquid in a thermometer, the divergence of the gold leaves of an electroscope, and so forth.

Dissolving views are obtained by arranging two magic lanterns, *A* and *B*, which are quite alike, with different pictures, in such a manner that both pictures are produced on exactly the same part *E* of a screen *FG* (fig. 609). The object-glasses of both lanterns can be closed by toothed plates (fig. 610), so

that when one, A, passes slowly in front of the object-glass e , a second one, B, exposes the other at the same time, the motion being effected by the rack and pinion motion M. In this way one picture is gradually seen to change into the other. In the better forms the two lanterns are arranged vertically.



Fig. 609

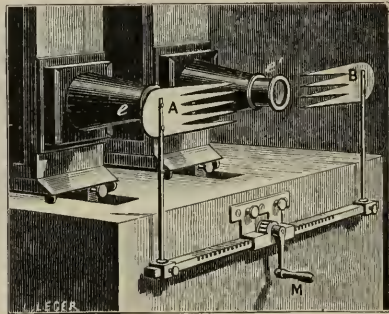

Fig. 610

The magnifying power of the magic lantern is obtained by dividing the distance of the lens from the image by its distance from the object. If the image is 100 or 1000 times farther from the lens than the object, the image will be 100 or 1000 times as large. Hence a lens with a very short focus can produce a very large image, provided the screen is sufficiently large.

617. **Solar microscope.**—The solar microscope is a magic lantern illuminated by the sun's rays which serves to produce highly magnified images of very small objects. It is worked in a dark room: fig. 611 represents it fitted in the shutter of a room, and fig. 612 gives the internal details.

The sun's rays fall on a plane mirror, M, placed outside the room, and are reflected towards a condensing lens, l , and thence to a second lens, o (fig. 612), by which they are concentrated at its focus. The object to be magnified is at this point; it is placed between two glass plates, which, by means of a spring, n , are kept in a firm position between two metal plates, m . The object thus strongly illuminated is very near the focus of a system of three condensing lenses, x , which forms upon a screen at a suitable distance an inverted and greatly magnified image, ab . The distance of the lenses o and x from the object is regulated by means of screws, C and D.

As the direction of the sun's light is continually varying, the position of the mirror outside the shutter must also be changed, so that the reflection is always in the direction of the axis of the microscope. The most exact apparatus for this purpose is the heliostat (543); but as this instrument is very expensive, the object is usually attained by inclining the mirror to a greater or less extent by means of an endless screw B, and at the same time turning the mirror itself round the lens l by a knob A, which moves in a fixed slide.

The solar microscope labours under the objection of concentrating great heat on the object, which soon alters it. This is partially obviated by interposing a layer of a saturated solution of alum, which, being a powerfully athermanous substance (439), cuts off a considerable portion of the heat.

The magnifying power of the solar microscope may be deduced experimentally by substituting for the object a glass plate marked with lines at a

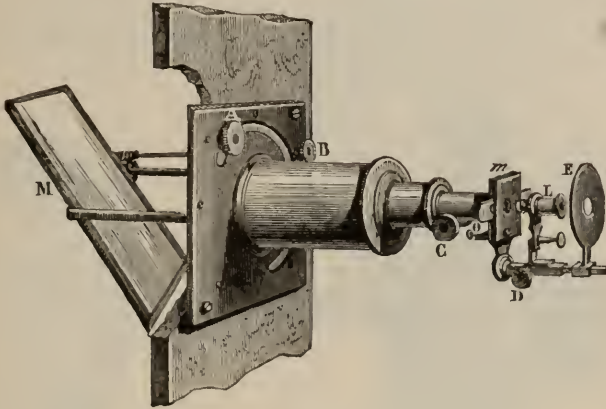

Fig. 611

distance of $\frac{1}{10}$ or $\frac{1}{100}$ of a millimetre apart. By measuring the distance between two of these lines on the image, we may calculate the magnifying power. According to the magnifying power which it is desired to obtain, the objective *x* (fig. 612) is formed of one, two, or three lenses, which are all achromatic.

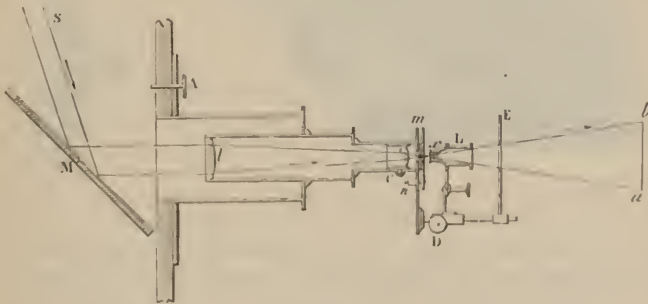

Fig. 612

618. **Photo-electric microscope.**—This is in effect a solar microscope which is illuminated by the electric light instead of by the sun's rays. The electric light, by its intensity, its steadiness, and the readiness with which it can be produced at any time of the day, has in practice replaced the use of sunlight. The microscope alone will be described here: the production of the electric light will be considered later.

Fig. 613 represents the arrangement devised by Duboscq. A solar microscope, ABD, identical with that already described, is fixed on the outside of a brass box. In the interior are two carbon points which do not quite touch, the space between them being exactly on the axis of the lenses.

When the current from a battery or dynamo passes, a luminous arc is formed between the two ends of the carbons, which gives a most brilliant light. By a condensing lens in B the light is concentrated, and powerfully illuminates the objects to be projected, and the same effects are produced as

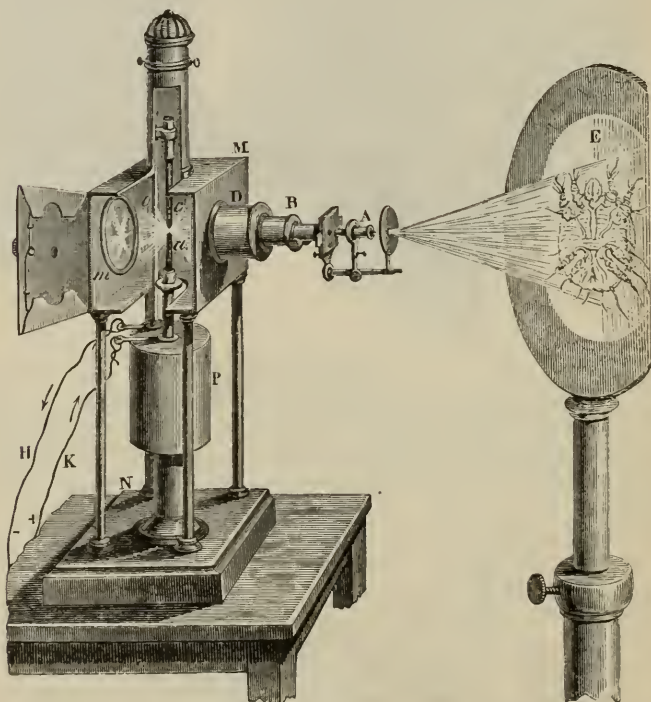

Fig. 613

with the ordinary solar microscope ; a magnified and inverted image of the object placed between two plates of glass is produced on the screen.

The part of the apparatus MN may be considered as a universal *photogenic* or *projection apparatus*. The microscope can be replaced by the head-pieces of the phantasmagoria, the polyorama, the megascope, by polarising apparatus, &c., and in this manner is admirably adapted for exhibiting optical phenomena to a large audience. Instead of the electric light, we may use with this apparatus the *oxyhydrogen* or *Drummond's* light, which is obtained by heating a cylinder of lime in the flame produced by the combustion of hydrogen or of coal gas in oxygen gas.

619. **Lighthouse lenses.**—Lenses of large dimensions are very difficult of construction; they further produce considerable spherical aberration, and their thickness causes the loss of much light. In order to avoid these inconveniences, *echelon*

lenses have been constructed. They consist of a plano-convex lens, C (figs. 614 and 615), surrounded by a series of annular and concentric segments, A, B, each of which has a plane face on the same side as the plane face of the central lens, while the face on the other side has such a curvature that the foci of the different segments coincide in the same point. These rings form, together with the central lens, a

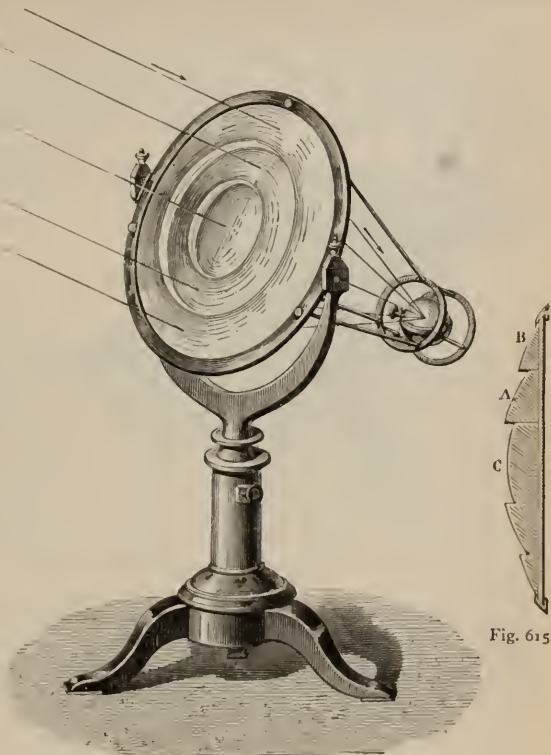

Fig. 614

Fig. 615

single lens, a section of which is represented in fig. 615. The drawing was made from a lens of about 2 feet in diameter, the segments of which are formed of a single piece of glass; but, with larger lenses, each segment is likewise formed of several pieces.

Behind the lens there is a support fixed by three rods, on which a body can be placed and submitted to the sun's rays. As the centre of the support coincides with the focus of the lens, the substances placed there are melted and volatilised by the high temperature produced. Gold, platinum, and quartz are melted.

Formerly, parabolic mirrors were used in sending the light of beacons and lighthouses to great distances, but they have been supplanted by the use of lenses of the above construction. In most cases oil is used in a lamp of special construction. The light is placed at the principal focus of the lens, so that the emergent rays form a parallel beam which loses intensity only by absorption in the atmosphere, and can be seen at a distance of about forty miles. In order that all points of the horizon may be successively

illuminated, the lens is continually moved round the lamp by clockwork motion, the rate of which varies with different lighthouses. Hence, at the same place the light alternately appears and disappears after equal intervals of time. These alternations serve to distinguish lighthouses from an accidental fire or a star. By means, too, of the number of times the light disappears in a given time, and by the colour of the light, sailors are enabled to distinguish the lighthouses from one another, and so to know their position.

Of late years the use of the electric light has to a large extent been substituted for that of oil lamps. A description of the apparatus will be given in a subsequent chapter.

PHOTOGRAPHY

620. **Photography** is the art of producing permanent images of objects by utilising the changes which certain substances undergo by the action of light.

Although the darkening action of light on silver chloride was known to the alchemists of the sixteenth century, no real advance can be said to have been made until nearly a century later, when Scheele, the Swedish chemist, in 1770, investigated the effect of sunlight on silver chloride, and his labours were crowned by the discovery of chlorine.

Thirty-two years later Thomas Wedgwood and Humphry Davy read a paper before the Royal Institution, entitled 'A Method of copying Paintings on Glass, and of making Profiles by the agency of Light upon Nitrate of Silver.'

In 1810 Dr. Seebeck observed, when projecting the solar spectrum on paper containing silver chloride moistened with nitrate of silver, that the silver salt was not merely blackened, but that an approximation to the natural colours was produced in their relative positions in the spectrum.

In 1814 Niepce patented a process of 'héliographie' by coating a metal plate with a solution of bitumen dissolved in oil of lavender, and exposing in the camera. After an exposure of several hours, the plate was developed by a mixture of oil of lavender in white petroleum, which dissolved the unaffected parts of the film. The layer of bitumen had to be very thin. This was the first process by which photographic images could be fixed. This process was tedious and inefficient, and quite useless for portraying living objects, and it was not till 1839 that two practical methods were discovered. In that year, Daguerre in Paris and Fox Talbot in England published their respective processes. The latter investigator is really the father of modern photography.

In Daguerre's process, the *Daguerreotype*, the image is produced on a copper plate covered with silver, the silver surface having been made chemically clean and highly polished. The silver is made sensitive to light by exposing it to the action of iodine vapour, till a thin film of iodide of silver is formed. The sensitiveness is considerably increased if, after the iodine has acted for some time, it is exposed to the fumes given off from bromide of lime; by this method a bromiodide of silver is formed. The plate is then exposed in a camera such as is depicted in figs. 616 and 617. No change on the surface of the plate is visible after exposure. In order to reveal the action

of light it is submitted to the action of mercury vapour. The mercury is contained in an iron vessel and raised to a temperature of about 50° C. If the exposure has been correctly adjusted a brilliant image in all its details soon appears. Where light has acted there the mercury vapour condenses, but no such condensation takes place on the unexposed portions. The surface of the plate is still covered with bromiodide of silver, which must be dissolved away. This is done by flooding the surface with a solution of hyposulphite of soda.

This property of hyposulphite of soda of dissolving the silver haloids was discovered by Herschel in 1821. The image on the plates consists partly of a silver amalgam corresponding to the high lights and of bright metallic silver in the shadows. In some cases the image was gilded by flooding the plate with a warm solution of hyposulphite of gold and sodium, which was deposited more on the shadows than on the amalgam, and then washing with distilled water so that no deposit of lime salts should be left after the water had evaporated.

Fox Talbot introduced his calotype process, which for portraiture had an advantage over that of Daguerre, in that after one sitting a number of copies could be obtained from the result, while in the case of the daguerreotype a fresh sitting was necessary for each copy required. The daguerreotype is

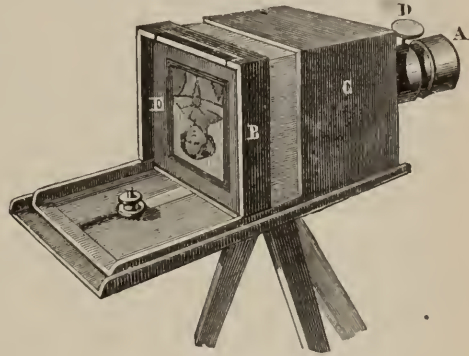

Fig. 616

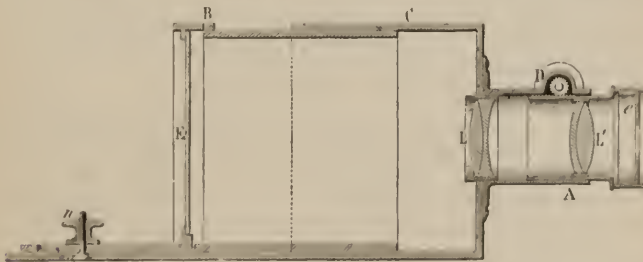

Fig. 617

true to nature as regards light and shade, but the calotype is reversed, *i.e.* the high lights are opaque to transmitted light and the shadows translucent. Advantage was taken of this in order to multiply copies, since, if a piece of paper sensitive to light was placed under the negative and then exposed to light, the silver image would stop light in proportion to its amount present, and the translucent parts would allow it to pass on; thus the half tones and shadows would be produced in the copies. The paper may be made more

transparent by being impregnated with wax, the excess being removed by placing it between two sheets of blotting paper, and passing a hot iron over the whole.

Calotype paper can be prepared by brushing over the surface of close-grained and smooth paper iodide of silver dissolved in a strong solution of iodide of potassium, and, after the solution has soaked into the paper, floating the paper on water. Iodide of silver is only sparingly soluble in a weak solution of iodide of potassium, so that by floating the paper on water a large quantity of iodide of silver is precipitated in the pores of the paper, and at the same time the iodide of potassium is removed. Paper thus prepared can be kept for any length of time and is not affected by exposure to light. In order to render it sensitive the surface must be brushed over with a solution of nitrate of silver, gallic acid, and acetic acid. After the paper has been exposed to light a more concentrated solution of the same reagents brings about a deposition of silver on the parts exposed. The fixing agent is hyposulphite of soda.

A camera is simply a dark box with a lens at one end, and a piece of ground glass fitted in a frame, running in grooves, at the other. The lens mount is usually provided with a rack and pinion for the final focusing. The camera is placed in front of the object to be depicted, and the back of the camera, with its ground glass, moved to or from the lens till the image is in fair focus, then the rack and pinion is used for the minute adjustment. When the image is properly situated on the ground glass and the focusing completed, the frame is removed and a dark slide is introduced in its place. The sensitive surface of the plate is made to occupy the same position as the ground surface of the glass, otherwise the resulting picture will not be sharp. The dark slide is a frame with a hinged door at the back, and inside there are carriers to take different sized plates. The dark slide when in the camera can be opened towards the lens, so that when the cap is removed only the light which passes through the lens and forms the image can fall on the plate. The time of exposure in any case depends on the brilliancy of the image, the opening in the lens, the speed of the plate, and other conditions which experience only can decide.

621. **Collodion pictures.**—Le Grey, of Paris, was the first to suggest the use of collodion, a solution of pyroxylin in alcohol and ether, as the vehicle to fix the salts of silver on the surface of glass plates. Scott Archer, in 1850, was the first to use collodion practically. Iodides soluble in alcohol and ether are added to the collodion. When the plate has been coated with this mixture and the bulk of the ether has evaporated, a kind of skin containing the iodides is left on the plate. It is then plunged into a solution of nitrate of silver, 30 grains to the ounce, and left in it for two or three minutes, so that by double decomposition iodide of silver shall be found in the pores of the film; at the end of that time the plate is removed, drained, and placed in the dark slide. After he has made the exposure and returned to the dark room the operator pours over the horizontal surface a solution of some reducer together with acetic acid to retard the action. The reducers used were pyrogallic acid and ferrous sulphate. Both these substances will reduce silver from nitrate of silver. The silver in the nascent state becomes attached to those portions of the film which have been exposed to light.

The iodide of silver in the film does not, by the action of the developer, become reduced to the metallic state, it simply determines the position where the silver shall be deposited; this kind of development is usually called physical development, in order to distinguish it from the other kind in which the image is formed entirely by silver, reduced by the developer from the salt of silver impressed by light. The sensitising of the plate and the development must naturally take place in a room illuminated by non-actinic light. As iodide of silver is not affected by yellow or orange light either of these can be used. Fixation is best effected by cyanide of potassium.

The wet collodion process was much improved later by the use of both iodide and bromide of silver in the film, and with pure chemicals and a recently made neutral bath instantaneous pictures of moving objects could be easily taken. One great drawback of the process was the bulk and weight that had to be carried to the spot where it was necessary to take a picture, but at the same time one was certain of having obtained what one desired before departing from the scene.

Bolton and Sayce, in 1864, found that it was not necessary to sensitise each plate separately, but that, if the requisite quantity of nitrate of silver was added, dissolved in alcohol, to the collodion, finely divided haloid salts of silver could therein be formed, and that the plates could then be coated. After coating, all that remained to be done was to wash out the soluble salts due to double decomposition and dry the plates. These could then be placed in dark slides, and thus tent, baths, &c., were no longer required in the field. Increase in speed was obtained by omitting entirely the iodide of silver, so that the film consisted simply of dry pyroxylin and silver bromide.

Plates thus prepared are much slower than wet collodion plates.

622. Gelatine emulsions. Dry plates. Orthochromatic plates.—The greatest advance is due to Dr. Maddox, who, in 1871, substituted gelatine for collodion; by this slight change enormous increase in speed was obtained. When silver nitrate is added to a solution of gelatine in water containing a soluble bromide, silver bromide is formed throughout the liquid in a very finely divided state, and does not subside even after long standing. This *emulsion* can be made in gallons at a time. Bennett showed that duration of exposure could be diminished if after the addition of the nitrate of silver to the liquefied gelatine and bromide the emulsion was kept in the liquid state for eight or ten days, but he noticed at the same time that although speed was obtained the gelatine began to deteriorate, and that frequently during development the whole film would leave the glass plate. Bolton showed, some time after, that improved results could be obtained by omitting the bulk of the gelatine in the early stages and boiling the emulsion for about thirty minutes, and that when the emulsion had ripened to the proper state and had cooled to about 35° C., the proper amount of gelatine could be added without impairing the speed, and that the gelatine set and did not frill during the subsequent operations. After the gelatine has set it is then subdivided, and washed in running water till all soluble salts are removed. During the emulsification an excess of soluble bromide is necessary. After the washing the emulsion is liquefied and plates coated.

Enormous quantities of plates are thus prepared annually, and under

proper conditions there is no reason why they should not remain good for an indefinite time. It is only when the ripening has been carried to an extreme, by the present methods of preparation, that the emulsion on the plate changes. In some cases the plates get slower and have a tendency to fog when developed. In other cases just the reverse happens. The ultimate speed obtained seems to be connected in some way with the quality of the gelatine, but as gelatine is such an uncertain and complex body it is not astonishing that this should happen.

Wet collodion is seldom used now for portraiture or views. Even after the introduction of gelatine, wet collodion was generally employed for photo-mechanical processes, but at the present time slow gelatine plates are used, and the results are quite as satisfactory as with wet collodion. The great difficulty, at first, was to prepare such an emulsion that plates made from it would be free from fog or stain in those portions which ought to be perfectly clear.

The sensitiveness of a wet plate does not extend beyond the blue, and consequently the dark room could be lighted with yellow or orange light. In the case of ordinary gelatine plates it extends down to the green, and if exposed long enough even lower, so that it soon became necessary to change the orange glass for ruby in order to prevent the plates being light fogged during development.

In 1878 Abney prepared collodio-bromide sensitive to the red and the infra-red of the spectrum.

In 1881 Vogel and Waterhouse found that gelatine plates could be made sensitive to rays of lower refrangibility than green by associating with the emulsion during its preparation, or by bathing the finished plate in, a solution containing a trace of erythrosin. Plates thus prepared are sensitive to orange as far as the 'D' lines. By the use of cyanine the sensitiveness extends down into the red. Although the emulsion is made sensitive to the rays of lower refrangibility, it does not lose its sensitiveness to the blue and violet, so that if a painting containing red and blue was photographed on such a plate, usually called 'isochromatic' or 'orthochromatic,' the photograph would not be much better than that produced by an ordinary plate; the red would come out slightly less dark, but the blue would still come out white. In order therefore to diminish the effect of the blue and allow time for the red to act, a yellow screen is used during the exposure—*i.e.* the light before reaching the plate is filtered through some yellow medium so that the intensity of the blue and violet is considerably reduced; the same result would be obtained if the picture were illuminated by yellow light.

622A. **Films.**—Fox Talbot used paper as the support for the sensitive salts in the case of the 'calotype.' Sir John Herschel first suggested and actually used glass as the support for iodide of silver in order to depict heavenly bodies, but this salt was so insensitive that it was abandoned. Glass was almost always used in connection with the wet process, but it is heavy and brittle, and for a long time a better substitute was sought. In 1889 Eastman introduced transparent celluloid as a support for gelatine emulsion, and devised at the same time his 'roll holder.' By these means sufficient length of film could be carried for forty or fifty exposures without increasing very much the bulk or weight of the apparatus. The roll holder

has now given way to 'daylight-spools'; these consist of a length of celluloid coated with emulsion, and attached to a backing of black paper, which is 10 or 12 inches longer at each end than the film itself. This can then be wound on a kind of bobbin, and light cannot obtain access to the film as it is wrapped round closely by the excess of black paper. These can be fitted in the camera in broad daylight, and when the back of the camera is closed the excess of paper is wound on an empty spool; as each length is exposed it is wound on this same spool. The transfer of the right length from one spool to the other is ascertained by a figure becoming visible through a circular hole in the back of the camera, the opening being covered with red glass. When the whole length of the film has been exposed, the excess of black paper at the end is wound over all; this keeps out light, and the spool can be removed and replaced by another.

622B. **Developers.**—After the gelatine emulsion has been exposed to the light which has traversed the lens, no change is visible on the plate, but if certain solutions are applied, called developers, metallic silver is produced where the light acted, and the unexposed bromide of silver remains as before. In the early days of the development of gelatine plates pyrogallic acid was the main reducer. A solution of pyrogallic acid by itself will not develop, but if a small quantity of alkali, such as ammonia, is added, it acts very energetically, and in a short time will reduce to the metallic state not only the exposed salt, but also the unexposed; in order to prevent this a restrainer is used, bromide of potassium. Under the action of these three substances pyro, ammonia, and a soluble bromide, in correct proportions and with a properly exposed plate, within a certain time, only the exposed bromide is reduced to the metallic state. In France, for many years, ferrous oxalate was the favourite developer. Recently many new developers have been introduced, and these are usually employed with carbonate of soda or potash, and with the addition of sulphite of soda which retards the oxidation of the reducing agent.

When development is completed the plate is fixed in a strong solution of hyposulphite of soda, and then washed in ordinary water so as to remove all traces of soluble salts. When dry a negative, as it is usually called, is the result.

623. **Photographic printing.**—Negatives obtained by any of the methods can be used for the production of an indefinite number of positives. By printing nothing is taken from the negative, it simply serves as a kind of screen which allows different amounts of light to pass through, depending on the thickness of the deposits of silver. Those portions of the negative which correspond to the highest lights in nature stop all light, so that when paper sensitive to light is placed in contact with the film the change there is a minimum; at those parts, on the contrary, where there is no deposit of silver, corresponding to the shadows in the original, the light will pass through and produce the maximum effect; intermediate tones are represented by intermediate shades, and so the half tones are produced.

Prints were first produced on paper which had been coated with a dilute solution of albumen to which a certain amount of common salt had been added. When the coat of albumen was dry the paper was floated on a solution of nitrate of silver; by double decomposition chloride of silver was

formed, also an obscure body somewhat of the nature of albuminate of silver. The dry paper has, therefore, on its surface nitrate of silver, chloride of silver, and albuminate of silver. Chloride of silver in the presence of nitrate when exposed to light does not produce a pleasant colour, but when organic matter is present a much more satisfactory colour is obtained. The albumen, therefore, serves a threefold purpose : (*a*) it keeps the picture on the surface of the paper, (*b*) supplies the organic salt of silver, and (*c*) produces a glaze. The dilute solution was soon replaced by pure albumen undiluted, and in some cases the paper was double albumenised, the object being to obtain as great a glaze as possible. If pictures thus produced are simply fixed in hyposulphite of soda the resulting colour is a foxy red ; in order, therefore, that a more agreeable tone may be produced, the print is first washed and then transferred to a solution of chloride of gold, to which is added some salt of sodium (acetate, tungstate, carbonate, &c.), which is easily decomposed by the acid set free from the chloride of gold, again washed, and then fixed and washed. However great the care with which albumen prints have been prepared they all seem to fade in the course of years. There is always left in the paper a minute trace of silver which seems to start the destruction of the image.

Of late years gelatine has taken the place of albumen, and in this case also its use is to keep the image on the surface. The organic salt of silver associated with the chloride varies : in some cases it is citrate, in others tartrate or acetate. In the gelatino-chloride papers there is no free nitrate of silver. This paper keeps good for a much greater length of time than did the sensitised albumenised paper. It is toned and fixed in much the same way as the paper it displaced. Prints produced on this paper ought to last in good condition for many years if they have been properly fixed and washed, as there is no silver in the paper excepting that which constitutes the image.

Mungo Ponton, in 1839, announced to the Royal Scottish Society of Arts that bichromate of potassium might be used to sensitise paper. This discovery is the basis of many photo-mechanical processes, and also of the carbon process. If paper is coated with gelatine or albumen and bichromate of potassium and then dried, on exposure to light a feeble image is produced, but the most important change is that, at the parts where the light has acted the gelatine or albumen becomes insoluble in water, cold or warm, so that if such a piece of paper is printed under a negative of a line engraving, and the printing continued long enough, on soaking first in cold water and then in warm (about 48° to 50° C.), those portions of the gelatine that correspond to the transparent lines of the negative will remain, but the rest will be dissolved. If, instead of using plain gelatine, some colouring matter, say Indian ink, had been added to the gelatine, a black-lined print would result.

Difficulties arise if, instead of using a black and white negative, we use one in which there are half tones. The action of light penetrates to a depth into the film inversely proportional to the density of the negative ; where there is no deposit of silver in the negative the penetration will be a maximum, where the density is greatest there will be no action, and under the half tones of the negative the insoluble gelatine will be intermediate in thickness, but will be backed up by soluble gelatine. If such a print was developed in the same way as the one produced from a black and white

negative, as soon as the gelatine saturated with water was raised to such a temperature as to dissolve it, the half tones will float off the paper and leave only the deepest shadows. To avoid this the printed tissue is soaked in cold water and then squeegeed to a temporary support, which may be paper coated with a thin film of wax and rosin. When it is firmly adherent to this support development can take place as in the ordinary way. As soon as the gelatine begins to dissolve in the warm water the paper backing comes away, and by gently washing the gelatine on the temporary support all soluble gelatine will go into solution, while those parts which were exposed to light in the presence of the bichromate will remain attached to the support. Such a picture will naturally be laterally transposed. In order to obtain a correct view paper coated with insoluble gelatine is attached to it by bringing both into contact under water, removing the excess of water, and then allowing both to dry. When dry the two pieces of paper can be separated from each other, and the film will be found on this gelatinised paper, and so rectified as regards right and left.

Pigments of any colour, not affected by bichromate, can be used in conjunction with the gelatine. Pictures thus produced are reckoned among the most permanent; the paper may change, but if carbon or ferric oxide is the pigment the picture itself will not alter in colour. Of all the different paper processes, that in which platinum in a finely divided state forms the image must be the most permanent. The image is formed in the body of the paper just below the surface, and, since it consists of platinum black, there is nothing in prints produced by this method to alter. In the carbon process the image might skin off, but the platinum powder cannot come out of the paper.

Paper is made sensitive by being coated with ferric oxalate and potassium-chloroplatinite and then dried; it is of a lemon colour; on exposure to light it changes to a light lavender colour, so that the impression is very weak. The action of light on the ferric oxalate is to reduce it to the state of ferrous oxalate. Although the platinum salt is side by side with the ferrous oxalate no reduction takes place. In order to reduce the platinum salt to the metallic state, the ferrous oxalate and the platinum salt must come into contact in solution. Water will not do this, but a solution of oxalate of potassium dissolves the ferrous oxalate, so that as soon as the print is immersed in a solution of oxalate of potassium, the reduction takes place and the picture is produced. After the image has been developed to the depth required, it is at once plunged into dilute hydrochloric acid. The acid arrests further development and at the same time dissolves out the salts of iron. The prints have to be soaked for about five minutes in three or four changes of dilute acid, and then washed so as to remove the acid and the soluble salts of iron. By slight modifications in the preparation of the paper the developer can be used hot or cold, but in both cases the result is the same, namely, the production of platinum black.

When prints have to be made by artificial light or by enlargement, a thin layer of slow gelatino-bromide emulsion is spread on fine textured paper. After the exposure, development is carried out in exactly the same manner as for a negative; but here it is important that a non-staining developer should be used; the required result is generally secured by

increasing slightly the quantity of sulphite in the developer, or by dispensing with the organic developers and using ferrous oxalate dissolved in potassium oxalate, the same coloured image, namely black, is obtained.

624. **Photography in colour.**—If a piece of ordinary gelatino-chloride paper, or albuminised paper, is exposed to white light till a moderate tint is obtained, and then taken into a dark room and a bright spectrum projected on it, the paper prints, but the colour is different under the action of the coloured rays from what it would have been had white light been allowed to continue its action. Where the red end of the spectrum acts the sensitive body is changed from its original tint to a brick red, and the other parts give a rough representation of the colours of the spectrum. These colours, however, disappear when the paper is fixed.

Becquerel studied this same method of producing coloured pictures, but instead of paper used silvered copper sensitised as below. Though his results were better in the sense that the colours were a nearer approach to the originals, yet they suffered from the same defect that they could not be fixed; but if kept in the dark and viewed only by candle-light, or very feeble white light, they lasted for a long time.

The method adopted by Becquerel to prepare his sensitive surface was to attach a silvered copper plate to the negative pole of a battery of two or three cells, a carbon or platinum plate being connected with the positive pole. These were then immersed in a solution of common salt as electrolyte, and the current allowed to pass till the blue of the third order appeared on the silvered surface, due to the formation of a thin film of chloride (or subchloride) of silver. The plate was then washed, dried, and raised to a moderately high temperature; it was then exposed to the coloured rays to be reproduced, and the picture was then finished. All attempts to fix the colours failed, as when any fixing agent was applied the colours disappeared, and their places were taken by a thin film of grey silver.

The most successful reproductions of coloured objects by pure photography are those by the Lippmann process. The conditions for success by

this process are that the emulsion on the plate shall be transparent, sensitive to all the colours and in optical contact with a reflecting surface. The emulsion is of special preparation, so that it is sensitive and yet transparent. The sensitive surface is in contact with mercury as a reflector. The original form of cell by means of which he made his first exposure is shown in fig. 618. A frame somewhat larger than the image to be produced has clamped on opposite sides two glass plates, one ordinary glass, the other covered with the special emulsion, the dry, sensitive surface being inwards. These are clamped together so as to be mercury tight. Just before exposure

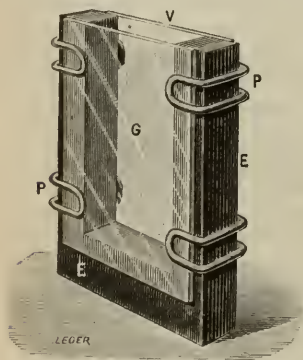

Fig. 618

the space between the plates is filled with pure dry mercury.

To photograph the spectrum or other coloured image the plate thus

backed is exposed to the direct action of the light. Fig. 619 represents the arrangement used by Lippmann for the production of the spectrum of the electric light. R is the electric lamp, L, L_1 , L_2 lenses, O a narrow slit, and P a direct vision compound prism to disperse the light and produce the spectrum at G. E is the cell with plate as above described. The plate after exposure is developed and fixed. When dry the colours of the original are visible by viewing the plate held at a certain angle. In order to get rid of reflection from the front surfaces of the film and glass, a thin prism is cemented to the film side of the picture. In that way the light reflected from the layers of the silver image only enters the eye. The colours are produced by interference and not by a pigment, and it is for this reason that they are visible in a certain direction only. Such a slide as above described could only be used in a laboratory, so in order to use the plates to photograph views, &c., some other form had

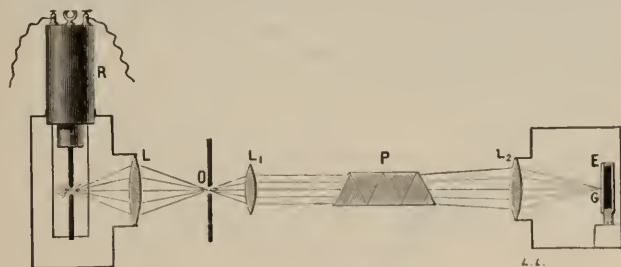

Fig. 619

to be devised; fig. 620 represents a section of one form. The ordinary dark slide is provided with a square inner frame, B, perfectly flat, on which rests the back of the plate G; the back of the slide is also plane, and has glued all round leather, H, about $\frac{1}{16}$ of an inch thick; by means of spring clamps, this leather is squeezed tightly in contact with the sensitive surface of the plate. Mercury is contained in an iron bottle or india-rubber ball, N, provided with a stopcock T; a tube connects the reservoir of mercury to the slide, so that when the tap is turned the space between the back of the slide and the face of the plate can be filled with mercury. This is done just before the exposure is to be made; after the exposure the mercury can be returned to the reservoir.

In attempting an explanation of the production of the thin laminae of silver reduced at any point in the film, we must anticipate, and refer to what is said about the colours of thin plates (664). Let us deal in the first instance with monochromatic light, red for instance. When light of this colour, which has a definite wave-length, falls on the sensitive film it passes through it and finally reaches the surface of the mercury, by which it is reflected.

The incident and reflected rays within the film interfere with each other, forming a series of stationary waves of a length corresponding to red light in

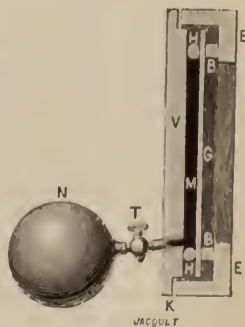

Fig. 620

this medium. Where increased illumination results, *i.e.* the crests of the waves, there on development silver is reduced; where, on the contrary, the waves interfere, no light action results and no silver is reduced by the developer. The net result is that we have layers of metallic silver in the gelatine film, when dry, separated from each other by distances exactly equal to the distance between the coincidences of the incident and reflected rays. When this same film is placed at such an angle that white light falls upon it, the whole of the colours are reflected, but reinforcement takes place only in the red, and the larger the number of laminæ within certain limits the more vivid the red. Assuming that the film is 0.1 mm. thick, and the wave-length of red light 0.00069 mm., there would be in such a film 140 laminæ, each reflecting red light to the eye. What is said of red light holds equally well for all other simple colours, the difference being only in the distance between the layers of silver. In the case of two or more colours falling on the same spot, we shall have different sets of waves interfering and reproducing the original colours.

CHAPTER VI

THE EYE CONSIDERED AS AN OPTICAL INSTRUMENT

625. **Structure of the human eye.**—The eye is placed in a bony cavity called the *orbit*; it is maintained in its position by the muscles which serve to move it, by the optic nerve, the conjunctiva, and the eyelids.

Fig. 621 represents a transverse section of the eye from back to front. The general shape is that of a sphere, or, more strictly speaking, it consists of the segments of two spheres of unequal size, of which the anterior is much the smaller and constitutes the *cornea*, while the posterior, forming the chief envelope of the eyeball, receives the name of the *sclerotic*. The eye is composed of the following parts: the *cornea*, the *sclerotic*, the *iris*, the *pupil*, the *aqueous humour*, the *crystalline*, the *vitreous body*, the *hyaloid membrane*, the *choroid*, the *retina*, and the *optic nerve*.

Cornea.—The cornea, D, is a transparent circular tunic forming the anterior segment of the eye. It is nothing more than a continuation of the sclerotic forwards, and is formed by the fibres of the latter becoming more systematically arranged and rendered quite transparent. Its front surface is lined throughout by the *conjunctiva*. This is a soft membrane

which not only covers the cornea, but, passing in a loose fold to the circumference of the orbit, is reflected over the under surface of the lids, thus completely closing in the cavity of the eyeball, and yet being so loose that the eye can roll freely in its socket. The two surfaces of the cornea are so nearly parallel that optically they may be considered as a single surface.

Sclerotic.—This (fig. 621, E) is a strong tough tunic enveloping the whole of the eye behind the cornea. At its back part it is reflected over the optic nerve, forming a sheath for it as far as the apex of the orbit. The chief functions of the sclerotic are to maintain the shape of the organ, and to protect it from injury and pressure.

Iris.—The iris, *bb*, is an annular opaque diaphragm, placed between the cornea and the crystalline lens. It constitutes the coloured part of the eye, and is perforated by an aperture called the *pupil*, which in man is circular. In some animals, especially those belonging to the genus *Felis*, it is narrow and elongated in a vertical direction; in the ruminants it is elongated in a

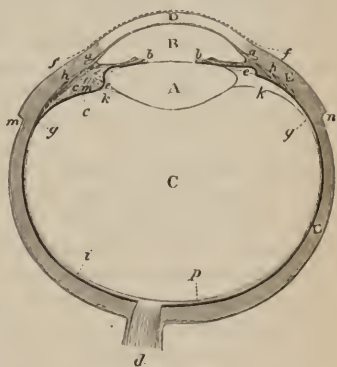

Fig. 621

transverse direction. It contains a large number of muscular fibres, which are disposed partly as a narrow ring close to the pupil, called the *sphincter iridis*, and partly in the form of fibres radiating from the circumference to the sphincter, called the *dilatator iridis*. Thus, as the one or the other set of fibres is stimulated, the pupil is able to contract or dilate. The diameter of the pupil is constantly varying, the variation ranging from $\frac{1}{3}$ to $\frac{1}{20}$ of an inch, but these limits may be exceeded. In total darkness the pupil is enlarged to its utmost limits, but it contracts instantly in a bright light. The movements of the iris are involuntary.

It appears from this description that the iris is a screen with a variable aperture, whose function is to regulate the quantity of light which penetrates into the eye; for the size of the pupil diminishes as the intensity of light increases. The iris serves also to correct the spherical aberration, as it prevents the marginal rays from passing through the edges of the crystalline lens. It thus plays the same part with reference to the eye that a stop does in optical instruments (570).

Aqueous humour.—Between the posterior part of the cornea and the front of the crystalline there is a transparent liquid called the aqueous humour. The space, B, occupied by this humour is called the *anterior* in contradistinction to the *posterior chamber*, a space which the older anatomists imagined to exist between the iris and the capsule of the lens. But inasmuch as later observations have shown that the iris lies in contact with the lens in its capsule throughout the greater part of its length, this space has no practical existence.

Crystalline lens.—This (fig. 621, A) is a double convex transparent body placed immediately behind the iris, which it supports, though not attached to it. The lens is enclosed in a transparent membrane, called its *capsule*. The structure of the lens can be best seen by boiling it in water, which converts it into a hard opaque mass. A succession of concentric laminæ, like the coats of an onion, may be stripped off, leaving a hard central spherical nucleus of the same material. These laminæ increase in density and refracting power from the circumference to the centre. They consist entirely of long ribbon-shaped fibres, which overlap one another concentrically, and are united together by a kind of cement. Optically, the lens may be considered as a system made up of a biconvex lens of high refracting power and short focal length, enclosed by two diverging meniscus lenses of lower refracting power. Opticians have constructed achromatic lenses on the same lines for photographic purposes by cementing two diverging meniscus crown lenses to an intermediate biconvex flint lens.

To the anterior surface of the capsule, near its margin, is fixed a firm transparent membrane, known as the *suspensory ligament* or *zonule of Zinn, ee*, which is attached behind to the front of the hyaloid membrane, and indirectly to the ciliary muscle, *m*. This ligament exerts traction, all round, on the front surface of the lens, and renders it less convex than it would otherwise be, and its relaxation plays an important part in the adaptation of the eye for sight at different distances.

Vitreous body. *Hyaloid membrane*.—The vitreous body, or vitreous humour, is a transparent gelatinous mass resembling the white of an egg, which occupies all the part of the ball of the eye, C, behind the lens. The

vitreous humour is surrounded by the *hyaloid membrane*, *kk*, which lines the posterior face of the crystalline capsule, and also the inner face of another membrane called the retina.

Retina. Optic nerve.—The retina, *i*, is the name given to a layer of specially modified cells which receives the impression of light. It is really nothing more than the terminal fibres of the optic nerve, altered in such a way as to be sensitive to the waves of light. Each optic nerve which conveys to the mind the impression produced by light arises from three centres in the brain, and the fibres, becoming collected into a thick cord, pass forward along the base of the brain. Here each cord, after forming a junction with its fellow of the opposite side, again separates, and, passing through a hole at the back of each socket, reaches and enters the eyeball, inside which it expands into a cup-shaped network of nerves called the *retina*. The nerve fibres themselves are not sensitive to light, but are only stimulated by it indirectly through the intervention of certain specially adapted cells. The fibres of the optic nerve, when they spread out to form the inner layer of the retina, after running a shorter or longer distance turn abruptly outward, and each fibre becomes connected with a larger ganglion cell, which again is connected by other processes with smaller cells; and each group of these finally ends in either a peculiarly shaped cylinder called a *rod*, or a thicker flask-shaped structure called a *cone*. All are ranged perpendicular to the surface of the retina, closely packed together, so as to form a regular mosaic layer when viewed from the outside. In the retina is a remarkable spot, *p*, which is situated in the axis of vision a little to the outside of the place where the optic nerve enters the eyeball. From its colour it is called the *macula lutea* or *yellow spot*. The retina is here somewhat thick, but in the middle of the yellow spot is found a depression, the *fovea centralis*, where the retina is reduced to those elements alone which are absolutely necessary for exact vision. This *fovea*, or pit of the retina, is of great importance for vision, since it is the spot where the most exact discrimination of distance is made. Only those parts of the retinal image which fall on the yellow spot are sharp, all the rest are more inaccurate the nearer they fall to the limits of the retina. The field of view of the eye is like a drawing, the centre of which is done with great accuracy and delicacy, while the surrounding part is only roughly sketched. Where the optic nerve enters there are no rods or cones; this part of the retina, therefore, is insensitive to light, and is called the *punctum cæcum* or *blind spot*. When examined in the living subject by means of the ophthalmoscope it appears as a slightly oval pinkish disc crossed by numerous blood-vessels.

The only property of the retina and optic nerve is that of receiving and transmitting to the brain the impression of objects. These organs have been cut and pricked without causing any pain to the animals submitted to these experiments; but there is reason to believe that irritation of the optic nerve causes the sensation of a flash of light.

Choroid.—The choroid, *g*, shown by a thick black line in the figure, is a membrane between the retina and the sclerotic. It is highly vascular, and supplies the nourishment necessary for the chemical and physiological processes concerned in vision. On its inner surface, and in close contact with the ends of the rods and cones, is a layer of densely black pigment cells

which secrete a peculiar yellowish purple pigment called the *visual purple*, which is rapidly bleached by light. It is evidently connected with the act of vision, but its precise use is uncertain.

The choroid forms a series of convoluted folds in front, called *ciliary processes*, which penetrate between the iris and the lens capsule, forming round the latter a disc resembling a radiated flower. The ciliary processes secrete the colourless fluid necessary for the nourishment of the transparent parts of the eye, which, being transparent for visual purposes, cannot be nourished by means of blood-vessels.

626. **Refractive indices of the transparent media of the eye.**—The refractive indices from air into the transparent parts of the eye were determined by Brewster, and have since been carefully examined by Von Helmholtz. The results of the latter are contained in the following table, compared with water as a standard :—

Water	1.3358
Aqueous humour	1.3365
Vitreous humour	1.3365
Cornea	1.3365
External coating of the lens	1.3930
Centre of the lens	1.4541
Mean refraction of the lens	1.4371

From this it will be noticed that the refractive indices of all the media excepting the lens are the same.

627. **Curvatures and dimensions of various parts of the human eye.**—According to the latest tables of Von Helmholtz (1888), these are :—

Radius of curvature of the cornea	min.	7.83
" " anterior surface of the crystalline		10.00
" " posterior surface " " 		6.00
Distance from apex of the cornea to the anterior surface of the lens		3.60
" " " posterior " " 		7.20
Thickness of the crystalline lens		3.60

628. **Path of rays in the eye.**—From what has been said as to the structure of the eye, it may be compared to a camera obscura (614), of which



Fig. 622

the pupil is the aperture, the crystalline is the condensing lens, and the retina is the screen on which the image is formed. Hence the effect is the same as when the image of an object placed in front of a double convex lens is formed at its conjugate focus. Let AB (fig. 622) be an object placed

before the eye, and let us consider the rays emitted from any point of the object A. Of all these rays, those which are directed towards the pupil are the only ones which penetrate the eye, and are operative in producing vision. These rays, on passing into the cornea, experience a first refraction which brings them near the secondary axis Aa drawn through the optic centre of the crystalline; they then traverse the crystalline, which again refracts them like a double convex lens, and, having experienced a final refraction by the vitreous humour, they meet in a point a , and form the image of the point A. The rays issuing from the point B form in like manner an image of it at the point b , so that a very small real and inverted image is formed exactly on the retina, provided the eye is in its normal condition.

629. **Inversion of images.**—In order to show that the images formed on the retina are really inverted, the eye of an albino or any animal with pink eyes may be taken; this has the advantage that, as the choroid is destitute of pigment, light can traverse it without loss. This is then deprived at its posterior part of the cellular tissue surrounding it, and fixed in a hole in the shutter of a dark room; by means of a lens it may be seen that the inverted images of external objects are depicted on the retina.

The inversion of images in the eye has greatly occupied both physicists and physiologists, and many theories have been proposed to explain how it is that we do not see inverted images of objects. The chief difficulty seems to have arisen from the conception of the mind or brain as something behind the eye, looking into it, and seeing the image upon the retina; whereas really this image simply causes a stimulation of the optic nerve, which produces some molecular change in some part of the brain; and it is only of this change, and not of the image as such, that we have any consciousness. The mind has thus no direct cognisance of the image upon the retina, or of the relative positions of its parts, and, sight being supplemented by touch in innumerable cases, it learns from the first to associate the sensations brought about by the stimulation of the retina (although due to an inverted image) with the correct position of the object as taught by touch.

630. **Optic axis, optic angle, visual angle.**—The *principal optic axis* of an eye is the axis of its figure; that is to say, the straight line in reference to



Fig. 623

which it is symmetrical. In a well-shaped eye it is the straight line passing through the centre of the pupil and of the crystalline. The lines Aa , Bb (fig. 622) are secondary axes. The eye sees objects most distinctly in the direction of the principal optic axis, since rays of light following this direction impinge upon the yellow spot where vision is most acute.

The *optic angle* is the angle BAC (fig. 623) formed between the principal optic axis of the two eyes when they are directed towards the same point. This angle is smaller in proportion as the objects are more distant.

The *visual angle* is the angle AOB (fig. 624) under which an object is seen ; that is to say, the angle formed by the secondary axes drawn from the optic

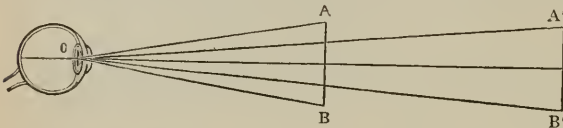

Fig. 624

centre of the crystalline to the opposite extremities of the object. For the same distance, this angle increases with the magnitude

of the object, and for the same object it decreases as the distance increases, as is the case when the object passes from AB to A'B'. It follows, therefore, that objects appear smaller in proportion as they are more distant ; for as the secondary axes, AO, BO, cross in the centre of the crystalline, the size of the image projected on the retina depends on the size of the visual angle AOB.

631. **Estimation of the distance and size of objects.**—The estimation of distance and of size depends on numerous circumstances : these are the visual angle, the optic angle, the comparison with objects whose size is familiar to us. To these must be added the effect of what is called *aerial perspective* ; that is, a more or less vaporous medium which enshrouds the distant objects, and thereby not only diminishes the sharpness of the outlines, but also softens the contrast between light and shade, which close at hand are marked.

When the size of an object is known, as the figure of a man, the height of a tree or of a house, the distance is estimated by the magnitude of the visual angle under which it is seen. If its size is unknown, it is judged relatively to that of objects which surround it.

A colonnade, an avenue of trees, the gas-lights on the side of a road, appear to diminish in size in proportion as their distance increases, because the visual angle decreases ; but the habit of seeing the columns, trees, &c., in their proper height, leads our judgment to rectify the impression produced by vision. Similarly, although distant mountains are seen under a very small angle, and occupy but a small space in the field of view, our familiarity with the effects of aerial perspective enables us to form a correct idea of their real magnitude.

As regards the estimation of near objects, the muscular senses of accommodation (634) and convergence (635) play a very important part. Thus it is well known that people who lose the sight of one eye experience great difficulty in estimating the distance of objects near at hand. This any one can prove for himself by covering up one of his eyes, and then attempting to thread a needle. The explanation of this difficulty is very simple. When one eye is destroyed or covered up, then owing to the absence of binocular vision there is no optic angle, and therefore convergence ceases to be called into play. Now the two chief guides for estimating the distance of near objects are the stereoscopic relief of objects due to binocular vision, and

the muscular sense of convergence. When only one eye is used both these factors are wanting. Nevertheless, it is only by long custom that we can establish a relation between our distance from the objects and the corresponding motion of the eyes. It is a curious fact that persons born blind, whose sight has been restored by the operation for cataract, imagine at first that all objects are at the same distance away.

Vertical distances are estimated too low compared with horizontal ones; on high mountains and over large surfaces of water, distances are estimated too low owing to the want of intervening objects. Practice and experience have great influence on our correct estimation of magnitude and distance. As we ascend mountains much less frequently than we walk on the level, we err more easily in estimating a height than in judging a horizontal distance. A room filled with furniture appears larger than an empty room of the same size.

We cannot recognise the true form of an object if, with moderate illumination, the visual angle is less than half a minute. A white square, a metre in the side, appears at a distance of about five miles under this angle as a bright spot which can scarcely be distinguished from a circle of the same size.

A very bright object, however, such as an incandescent platinum wire, is seen in a dark ground under an angle of 2 seconds. So, too, a small dark object is seen against a bright ground; thus a hair held against the sky can be seen at a distance of 1 or 2 metres.

632. **Scheiner's experiment.**—If we look at a small object placed either within or beyond the point on which the eye is focused, through a number of minute openings in a diaphragm, arranged so close together that they fall within the circumference of the pupil, the object appears multiple, each object furnishing a separate retinal image. This forms what is known as *Scheiner's experiment*. It may be made as follows: By means of a sewing needle, two small holes are pricked in a piece of cardboard, not more than $\frac{1}{16}$ of an inch apart, *i.e.* less than the diameter of the pupil. The card is held before one eye with the holes horizontally in front of the pupil, and with the other hand a needle is held at ordinary reading distance in the line of vision. If the eye is fixed on the needle itself, it appears single and clearly defined; as soon, however, as we look at a more distant object, the needle appears double, and at the same time blurred. If we block out the right-hand hole, the left-hand image disappears, and *vice versa*.

If we now fix the eye on an object nearer than the needle, the latter again appears double and blurred, and blocking either hole causes the image on the same side to vanish. The explanation of these phenomena may be simplified by the following diagram.

Let AB (fig. 625) be the two holes in the card CC, O a luminous point in the needle, OA, OB the pencils of rays passing through the apertures in the card. Let H, E, M represent the position of a hypermetropic, normal, and myopic eye respectively. When the normal eye E is accommodated for O, the rays OA, OB meet at the point E, and the needle appears sharply defined and single. If the eye is fixed on a point beyond, or, what amounts to the same thing, if the eye is hypermetropic, the retina may be considered to lie no longer at E, but in front at H, and the rays OAp not only do not

meet in a focus at p , but do not meet the rays OBp' ; hence the luminous spot O will be seen at two points, and the points themselves being out of

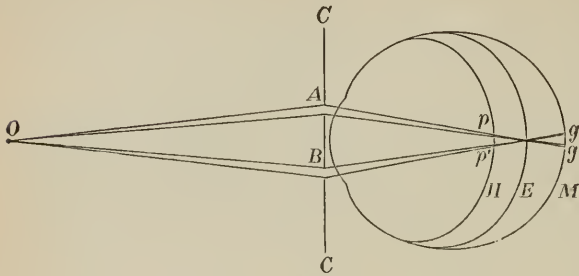

Fig. 625

focus will appear blurred. Moreover, the rays passing through the right-hand hole A will cut the retina at p , and will appear to the mind on the reverse side, *i.e.* on the left; therefore blocking the right-

hand hole A causes a disappearance of the left-hand image, and *vice versa*.

For similar reasons, if the eye is accommodated for a point nearer the eye than O , or, what amounts to the same thing, if the eye is myopic, the retina may be considered to lie behind E at M , and the image will again be seen doubled and blurred; only in this case blocking out the right-hand hole A will cause the right-hand image to disappear. Stamper constructed an optometer based on this principle. He employed a tube containing two diaphragms, one furnished with two slits 1 mm. apart, the other with a single slit covered with ground glass. The diaphragm is moved to or from the eye until the slit is seen single. This distance from the eye is the measure of distinct vision.

633. **Distance of distinct vision.**—The *distance of distinct vision*, as already stated (598), is the distance at which objects must be placed so as to be seen with the greatest distinctness. It varies in different individuals, and in the same individual it is often different in the two eyes. For small objects such as print, it is from 10 to 12 inches in normal cases.

Persons who see objects distinctly only at a very short distance away are called *myopic*, or *short-sighted*, and those who see objects distinctly at a long distance are *hypermetropic*, or *long-sighted* (643).

Sharpness of sight may be compared by reference to that of a normal eye taken as a unit. Such a standard eye, according to Snellen, recognises quadrangular letters when they are seen under an angle of $6'$; if, for instance, such letters are 1 cm. high at a distance of 6 metres. The sharpness of vision of one who recognises these letters at a distance of 6 metres is then said to be $\frac{6}{6}$, and in like manner, if the letters can only be distinctly seen when they subtend an angle of $9'$, $12'$, or $18'$, the sharpness of vision would be indicated by the equation $V = \frac{6}{9}$, $\frac{6}{12}$, and $\frac{6}{18}$ respectively.

634. **Accommodation.**—By this term are meant the changes which occur in the eye to fit it for seeing distinctly objects at different distances from it.

If the eye is supposed fixed and its parts immovable, it is evident that there could only be one surface whose image would fall exactly upon the retina; the one distance at which objects could be distinctly seen being

dependent on the refractive indices of the media and the curvatures of the refractive surfaces of the eye. The image of any point nearer the eye than this distance would fall behind the retina; the image of any more distant point would be formed in front of it.

Experience, however, shows us that a normal eye can see distinct images of objects at very different distances. We can, for example, see a distant tree through a window, and also a scratch on the pane, though not both distinctly at the same moment; for when the eye is arranged to see one clearly, the image of the other does not fall accurately upon the retina. An eye completely at rest seems adapted for seeing distant objects; the sense of effort is greater in a normal eye when a near object is looked at, after a distant one, than in the reverse case; and in paralysis of the nerves governing the accommodating apparatus, the eye is persistently adapted for distant sight. There must, therefore, be some mechanism in the eye by which it can be voluntarily altered, so that the more divergent rays proceeding from near objects shall come to a focus upon the retina. There are several conceivable methods by which this might be effected; it is actually brought about by a drawing forwards of the crystalline lens and a greater convexity of its front surface.

This is shown by the following experiment:—If a candle is placed on one side of the eye of a person looking at a distant object, and his eye is observed from the other side, three distinct images of the flame will be seen: the first, virtual and erect, is reflected from the anterior surface of the cornea; the next, erect and less bright, is reflected from the anterior surface of the lens; the third, inverted and brilliant, is due to the posterior surface of the lens. If now the person looks at a near object, no change is observed in the first and third images, but the second image becomes smaller and approaches the first; which shows that the anterior surface of the crystalline lens becomes more convex and approaches the cornea. In place of the candle, Von Helmholtz throws light through two holes in the screen upon the eye, and observes the distance on the eye between the two shining points, instead of the size of the flame of the candle.

This change in the lens is effected chiefly by means of a circular muscle (ciliary muscle), the contraction of which relaxes the suspensory ligament, and so allows the front surface of the lens to assume more or less of that greater convexity which it would normally exhibit were it not for the drag exercised upon it by the ligament. Certain other less important changes occur, tending to make the lens more convex and to push it forwards, which cannot, however, be explained without entering into minute anatomical details. When the eye is accommodated for near vision, the pupil contracts and so partially remedies the greater spherical aberration.

The *range of accommodation*, called by Donders $\frac{1}{A}$, is measured by first of all determining the greatest distance, R, at which a person can see distinctly. In this case the ciliary muscle is in a state of rest, that is, the accommodation is relaxed to the utmost. The shortest distance, P, is observed at which the person can see distinctly. In this case the ciliary muscle is contracted to its utmost power, that is, the accommodation has arrived at its maximum. The total accommodation power which an eye can bring into

play is therefore represented by the difference between the refraction of the eye when at rest, and when it is at the maximum effort of accommodation ; then

$$\frac{1}{A} = \frac{1}{P} - \frac{1}{R}.$$

Here each of the three terms represents a lens expressed by the inverse of its focal distance.

By the dioptric method (644) this formula is simplified, and becomes

$$a = p - r,$$

where a is the number of diopeters represented by the range of accommodation ; p = the number represented by the eye when accommodated to its maximum, and r = the number of diopeters when relaxed to see the *punctum remotum* ; in other words, a is the difference between the *powers* of the eye when viewing near and distant objects.

635. **Binocular vision.**—A single eye sees most distinctly any point situated on its optical axis, and less distinctly other points also, towards which it is not directly looking, but which are still within its circle of vision. It is able to judge of the *direction* of any such point, but unable by itself to estimate its *distance*. Of the distance of an *object* it may, indeed, learn to judge by such criteria as loss of colour, indistinctness of outline, decrease in magnitude, &c. ; but if the object is near, the single eye is not infallible, even with these aids.

When the two eyes are directed upon a single point, we then gain the power of judging of its distance as compared with that of any other point, and this we seem to gain by the sense of greater or less effort required in causing the optical axes to converge upon the one point or upon the other. Now a solid object may be regarded as composed of points which are at different distances from the eye. Hence, in looking at such an object, the axes of the two eyes are rapidly and insensibly varying their angle of convergence, and we as rapidly are gaining experience of the difference in distance of the various points of which the object is composed, or, in other words, an assurance of its solidity. Such kind of assurance is necessarily unattainable in monocular vision.

636. **The principle of the stereoscope.**—Let any solid object, such as a small box, be supposed to be held at some short distance in front of the

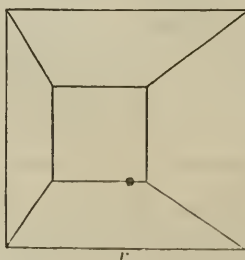
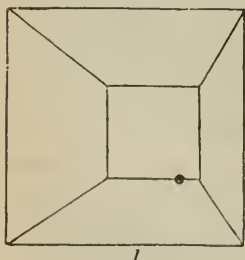

Fig. 626

two eyes. On whatever point of it they are fixed, they will see that point the most distinctly, and other points more or less clearly. But it is evident that, as the two eyes see from different points of view, there will be

formed in the right eye a picture of the object different from that formed in the left ; and it is by the apparent union of these two dissimilar pictures that we see the object

in relief. If, therefore, we delineate the object, first as seen by the right eye, and then as seen by the left, and afterwards present these dissimilar pictures again to the eyes, taking care to present to each eye that picture which was drawn from its own point of view, there would seem to be no reason why we should not see a representation of the object, as we saw the object

itself, in relief. Experiment confirms the supposition. If the object held before the eyes was a truncated pyramid, r and l (fig. 626) would represent its principal lines, as seen by the right and left eyes respectively. If a card is held between the figures, and they are steadily looked at, r by the right eye, and l simultaneously by the left, for a few seconds, there will be seen a single picture having the unmistakable appearance of relief. Even without a card interposed, the eye, by a little practice, may soon be taught so to combine the two as to form this solid picture. Three pictures will in that case be seen, the central one being solid, and the two outside ones plane. Fig. 627 will explain this. Let r and l be any two corresponding points, say the points marked by a large dot in the figures drawn above ; R and L the positions of the right and left eyes ; then the right eye sees the point r in the direction $R\sigma$, and the left eye the point l in the direction $L\sigma$, and accordingly each by itself judging only by the direction, they together see these two points as one, and imagine it to be situated at σ . But the right eye, though looking in the direction Rr , also receives an image of l on another part of the retina, and the left eye in the same way an image of r , and thus three images are seen. A card, however, placed in the position marked by the dotted line will, of course, cut off the two side pictures. To assist the eye in combining such pairs of dissimilar pictures, both mirrors and lenses have been made use of, and the instruments in which either of these are adapted to this end are called *stereoscopes*.

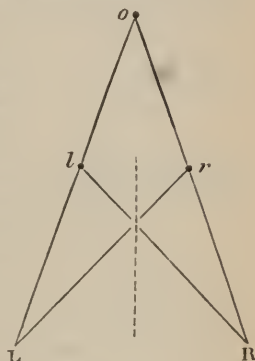

Fig. 627

Let r and l be any two corresponding points, say the points marked by a large dot in the figures drawn above ; R and L the positions of the right and left eyes ; then the right eye sees the point r in the direction $R\sigma$, and the left eye the point l in the direction $L\sigma$, and accordingly each by itself judging only by the direction, they together see these two points as one, and imagine it to be situated at σ . But the right eye, though looking in the direction Rr , also receives an image of l on another part of the retina, and the left eye in the same way an image of r , and thus three images are seen. A card, however, placed in the position marked by the dotted line will, of course, cut off the two side pictures. To assist the eye in combining such pairs of dissimilar pictures, both mirrors and lenses have been made use of, and the instruments in which either of these are adapted to this end are called *stereoscopes*.

637. **The reflecting stereoscope.**—In the reflecting stereoscope plane mirrors are used to change the apparent position of the pictures, so that they are both seen in the same direction, and their combination by the eye is thus rendered easy and almost inevitable.

If ab , ab (fig. 628) are two plane mirrors inclined to each other at an angle of 90° , the two arrows, x , y , would both be seen by the eyes situated at R and L in the position marked by the dotted arrow. If, instead of the arrows, we now substitute such a pair of dissimilar pictures as we have spoken of above, of the same solid object, it is evident that, if the margins of the pictures coincide, other corresponding points of the pictures will not.

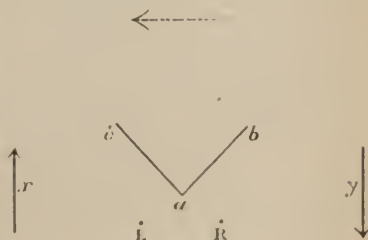

Fig. 628

The eyes, however, almost without effort, soon bring such points into coincidence, and in so doing make them

appear to recede or advance, as they are farther apart or nearer together than any two corresponding points (the right-hand corner, for instance) of the margins when the pictures are placed side by side, as in the diagram, fig. 628. It will be plain, also, on considering the position for the arrows in fig. 628, that to adapt such figures as those in fig. 627 for use in a reflecting stereoscope one of them must be reversed, or drawn as it would be seen through the paper if held up to the light.

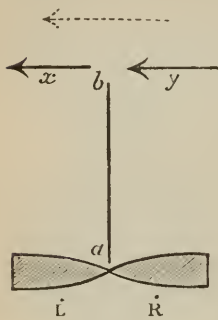

Fig. 629

the arrows, x, y , would both be seen in the position of the dotted arrow by the eyes at R and L.

If we substitute for the arrows two dissimilar pictures of the same solid object, or the same landscape, we shall then, if a diaphragm, ab , is placed between the lenses to prevent the pictures being seen crosswise by the eyes, see but one picture, and that apparently in the centre, and magnified. As before, if the margins are brought by the power of the lenses to coincide,

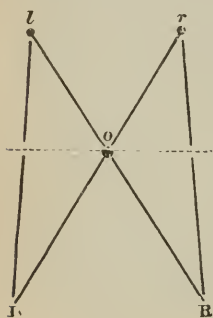

Fig. 630

other corresponding points will not be coincident until combined by an almost insensible effort of the eyes. Any pair of corresponding points which are farther apart than any other pair will then be seen farther back in the picture, just as any point in the background of a landscape would be found (if we came to compare two pictures of the landscape, one drawn by the right eye, and the other by the left) to be represented by two points farther apart from each other than two others which represented a point in the foreground.

It will be instructive to notice that there is also a second point on *this side* of the paper, at which, if a person look steadily, the diagrams in fig. 630 will combine, and form quite a different stereoscopic picture. Instead of a solid pyramid, a hollow pyramidal box will then be seen. The point may easily be found by experiment. Here again two external images will also be seen. If we wish to shut these out, and see only their central stereoscopic combination, we must use a diaphragm of paper held parallel to the plane of the picture, with a square hole in it. This paper screen must be so adjusted that it may conceal the right-hand figure from the left eye, and the left-hand figure from the right eye, while the central stereoscopic picture may be seen through the hole. It will be plain from the diagram (fig. 630) that o is the point to which the eyes must be directed, and at which they will imagine the point to be situated, which is formed by the combination of the two points r and l . The dotted line shows the position of the screen. A stereoscope with or without lenses may easily be

constructed, which will thus give us, with the ordinary stereoscopic slides, a reversed picture ; for instance, if the subject is a landscape, the foreground will retire and the background come forward.

When the two retinas view simultaneously two different colours, the impression produced is that of a single mixed tint. The power, however, of combining the two tints into a single one varies in different individuals, and in some is extremely weak. If two white discs at the base of the stereoscope are illuminated by two pencils of complementary colours, and if each coloured disc is looked at with one eye, a single white one is seen, showing that the sensation of white light may arise from two complementary and simultaneous chromatic impressions on each of the two retinas.

Dove found that if a piece of printing and a copy are viewed in the stereoscope, a difference in the distance of the words, which is not apparent to the naked eye, causes them to stand out from the plane of the paper.

639. **Persistence of impressions on the retina.**--When an ignited piece of charcoal is rapidly rotated, we cannot distinguish it ; the appearance of a circle of fire is produced ; similarly, rain, in falling drops, appears in the air like a series of liquid threads. In a rapidly rotating toothed wheel the individual teeth cannot be seen. But if, during darkness, the wheel is suddenly illuminated, as by the electric spark, the individual parts may be clearly made out. The following experiment is a further illustration of this property :—A series of equal sectors are traced on a disc of glass, and they are alternately blackened ; in the centre there is a pivot, on which a second disc is fixed of the same dimensions as the first, but completely blackened with the exception of a single sector ; then placing the apparatus between a window and the eye, the second disc is made to rotate. If the movement is slow, all the transparent sectors are seen, but only one at a time ; by a more rapid rotation we see simultaneously two, three, or a greater number. These various appearances are due to the fact that the impression of these images on the retina remains for some time after the object which has produced them has disappeared or become displaced. The duration of the persistence varies with the sensitiveness of the retina and the intensity of light.

Plateau investigated the duration of the impression by numerous similar methods, and has found that it is, on the average, half a second. Among many curious instances of these phenomena, the following is one of the most remarkable. If, after having looked at a brightly illuminated window, the eyes are suddenly closed, the image remains for a few instants—that is, a sashwork is seen consisting of luminous panes surrounded by dark frames ; after a few seconds the colours become interchanged, the same framework is now seen, but the frames are now bright, and the glasses are perfectly black ; this new appearance may again revert to the former one.

The impression of colours remains as well as that of the form of objects ; for if circles divided into sectors are painted in different colours, they become confounded, and give the sensation of the colour which would result from their mixture. Yellow and red give orange ; blue and red violet ; the seven colours of the spectrum give white, as shown in Newton's disc (fig. 559). This is a convenient method of studying the tints produced by mixed colours.

A great number of pieces of apparatus are founded on the persistence

of sensation on the retina : such are the *thaumatrope*, the *phenakistoscope*, *Faraday's wheel*, the *kaleidophone*, and the *zoetrope*.

The *zoetrope*, or *wheel of life*, is very convenient for representing a number of vibratory motions. It consists of an open cylinder which can be rotated about its vertical axis, with a number of vertical slits at the top. If the successive positions of a vibrating pendulum, for instance, are drawn on a narrow strip of paper, equal in length to the circumference, and this is placed inside the cylinder, when the wheel is rapidly rotated, we see on looking through the slits the pendulum as if it were steadily vibrating.

In the *kinematograph* a rapid succession of photographs of moving objects are taken, and successively projected in the same order on a screen, which allows a certain fixed short time of exposure to each picture before the next picture appears. In this way the most interesting and varied phenomena are vividly reproduced with lifelike accuracy.

640. **Accidental images.**—When a coloured object placed upon a black ground is steadily looked at for some time, the eye is soon tired, and the intensity of the colour is enfeebled ; if now the eyes are directed towards a white sheet or to the ceiling, an image will be seen of the same shape as the object, but of the complementary colour (581) ; that is, such a one as united to that of the object would form white. For a green object the image will be red ; if the object is yellow the image will be violet.

Accidental colours are of longer duration in proportion as the object has been more brilliantly illuminated, and has been longer looked at. When a lighted candle has been looked at for some time, and the eyes are turned towards a dark part of the room, the appearance of the flame remains, but it gradually changes colour ; it is first yellow, then it passes through orange to red, from red through violet to greenish blue, which is gradually feebler until it disappears. If the eye which has been looking at the light is turned towards a white wall, the colours follow almost the opposite direction : there is first a dark picture on a white ground, which gradually changes into blue, is then successively green and yellow, and ultimately cannot be distinguished from the white ground.

The reason of this phenomenon is to be sought in the fact that the subsequent action of light on the retina is not of equal duration for all colours, and that the decrease in the intensity of the subsequent action does not follow the same law for all colours. According to Külp, the durations of the after-image with moderate illumination are for white, yellow, red, and blue, 0·1, 0·09, 0·08, and 0·066 of a second respectively.

641. **Irradiation.**—This is a phenomenon in virtue of which white objects, or those of a very bright colour, when seen on a dark ground appear larger than they really are. Thus a white square upon a black ground seems larger than an exactly equal black square upon a white ground (fig. 631). Irradiation is due to the fact that the impression produced on the retina extends beyond the outline of the image. It bears the same relation to the space occupied by the image that the duration of the impression does to the time during which the image is seen.

The effect of irradiation is very perceptible in the apparent magnitude of stars, which may thus appear much larger than they really are ; also in the appearance of the moon when two or three days old, the brightly

illuminated crescent seeming to extend beyond the darker portion of the disc, and hold it in its grasp.

Plateau found that irradiation differs very much in different people, and even in the same person it differs on different days. He also found that irradiation increases with the lustre of the object, and the length of time during which it is viewed. It manifests itself at all distances; diverging lenses increase and condensing lenses diminish it.

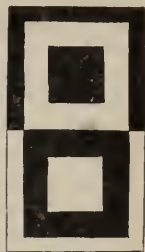

Fig. 631

Accidental haloes are the colours which, instead of succeeding the impression of an object like accidental colours, appear round the object itself when it is looked at fixedly. The impression of the halo is the opposite to that of the object: if the object is bright the halo is dark, and *vice versa*. These appearances are best produced as follows:—A white surface, such as a sheet of paper, is illuminated by coloured light, and a narrow opaque body held so as to cut off some of the coloured rays. In this manner a narrow shadow is obtained which is illuminated by the surrounding white daylight, and appears complementary to the coloured ground. If red glass is used, the shadow appears green, and blue when a yellow glass is used.

The *contrast of colours* is a reciprocal action exerted between two adjacent colours, in virtue of which to each one is added the complementary colour of the other. Chevreul found that when red and yellow colours are adjacent, red acquires a violet and yellow an orange tint. If the experiment is made with red and blue, the former acquires a yellow and the latter a green tint; with yellow and blue, yellow passes to orange, and blue towards indigo; if a narrow strip of grey paper is laid on a sheet of light green paper, it appears reddish, if laid on blue paper it seems yellow, and so on for a vast number of combinations; in all cases the colour is complementary to the colour of the base. The importance of this phenomenon in its application to the manufacture of coloured cloths, carpets, curtains, &c., may be readily conceived.

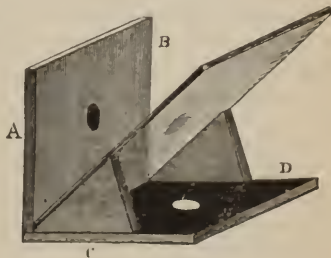

Fig. 632

The contrast may be conveniently examined by means of the apparatus shown in fig. 632 in about $\frac{1}{2}$ scale. It consists of a thin vertical board, AB, painted white, and the base, DC, painted black; thereon are painted circles about $\frac{3}{8}$ of an inch in diameter, black and white respectively. A sheet of coloured glass is inclined at an angle of 45° ; if now the eye is so situated that the image of the white circle on DC reflected from the under surface of the glass plate is looked at in front of the circle on AB, the image appears of a colour complementary to that of the glass. Thus with a green plate a red spot is seen on a green ground.

642. **The eye is not achromatic.**—It had long been supposed that the human eye was perfectly achromatic; but this is clearly impossible, as all the refractions are made the same way, viz. towards the axis; moreover, the

experiments of Wollaston, of Young, of Fraunhofer, and of Müller have shown that it was not true in any absolute sense.

Fraunhofer showed that in a telescope with two lenses, a very fine wire placed inside the instrument in the focus of the object-glass is seen distinctly through the eyepiece, when the telescope is illuminated with red light ; but it is invisible by violet light even when the eyepiece is in the same position. In order to see the wire again, the distance of the lenses must be diminished to a far greater extent than would correspond to the degree of refrangibility of violet light in glass. In this case, therefore, the effect must be due to a chromatic aberration in the eye.

Müller, on looking at a white disc on a dark ground, found that the image is sharp when the eye is accommodated to the distance of the disc, that is, when the image forms on the retina ; but he found that, if the image is formed in front of or behind the retina, the disc appears surrounded by a very narrow blue edge. If a finger is held up in front of one eye (the other being closed) in such a manner as to allow the light to enter only one half of the pupil, and, of course, obliquely, and if the eye is then directed to any well-defined line of light, such as a slit in the shutter of a darkened room, or a strip of white paper on a black ground, this line of light will appear as a complete spectrum.

Müller concluded from these experiments that the eye is sensibly achromatic as long as the image is received at the focal distance, or when it is accommodated to the distance of the object. The cause of this apparent achromatism cannot be exactly stated. It has generally been attributed to the tenuity of the luminous beams which pass through the pupillary aperture, and to the fact that these unequally refrangible rays, meeting the surfaces of the media of the eye almost at the normal incidence, are very little refracted, from which it follows that the chromatic aberration is imperceptible (594).

Spherical aberration, as we have already seen, is corrected by the iris (625). The iris is, in point of fact, a diaphragm, which stops the marginal rays and allows only those to pass which are near the axis. Spherical aberration is also diminished, by the fact that the refractive index of the crystalline lens decreases from the centre to the edge (626).

643. **Short sight and long sight. Emmetropia. Ametropia. Myopia and hypermetropia. Astigmatism. Presbyopia.**—The most usual deviations from normal refraction of the eye are *myopia*, *hypermetropia*, *presbyopia*, and *astigmatism*. *Myopia*, or short sight, is the inability to see objects clearly defined beyond a variable but always limited distance. The usual cause of myopia is an abnormal increase in length of the eyeball along the axis of vision, so that the retina lies behind the focus of the dioptric system of the eye for parallel rays, thereby rendering images on the retina indistinct. It may be remedied by means of diverging (concave) glasses, which, in making the rays deviate from their common axis, throw the focus farther back, and cause the image to be formed on the retina.

An eye which, when the accommodation is completely relaxed, can see distant objects distinctly—in other words, one in which parallel rays are sharply focused on the retina—is said to be *emmetropic*. All deviations from the normal refraction are included in the term *ametropia*.

The habitual contemplation of small objects, sedentary occupations, a

stooping position while studying, in fact anything which tends to congest the eyes, and cause an unequal strain on the muscles of convergence, may produce short sight. It is common in the case of young people, and when once acquired, tends to become hereditary; hence the percentage of myopes is continually on the increase in countries where education is becoming more advanced.

Hypermetropia, or long sight, is the contrary of short sight. The eye is abnormally short along the axis of vision, so that the retina lies in front of the focus of the dioptric system of the eye for parallel rays, thereby rendering objects on the retina indistinct unless the rays are rendered more convergent by exerting the muscles of accommodation. Hence the ciliary muscle can never be relaxed without the image becoming blurred, even when looking at distant objects. When regarding near objects, however, the accommodation has to be brought into play, not from a position of rest, but from the state of contraction of the ciliary muscle, which was necessary to see distant objects clearly. Owing to this increased strain of accommodation, the eye becomes easily fatigued when regarding near objects, which thus become blurred. Hypermetropia is corrected by means of converging (convex) lenses. These glasses converge the rays before their entrance into the eye, and therefore, if the converging power is properly chosen, the image will be formed exactly on the retina.

On applying a few drops of solution of atropine to the eye, the amount of hypermetropia will be found to be considerably increased. This additional increase is termed *latent* hypermetropia in contradistinction to the amount of hypermetropia discovered before the atropine was applied, or *manifest* hypermetropia.

Presbyopia.—As we grow older, the range of accommodation—in other words, the power of focusing near objects—decreases. There comes a time with every one who is not myopic when an object cannot be distinctly seen nearer than eight inches (the distance arbitrarily chosen by Donders). This occurs in a normal or *emmetropic* eye at forty years of age. Hence presbyopia, as it is called, may be defined as the contraction of the visual range due to physiological weakening of the accommodating mechanism. It is clear, according to the standard of Donders, that it can never occur in very short-sighted persons, as their near point is always much less than eight inches to begin with, whereas in hypermetropes, on the other hand, it may become evident at a much earlier age. Presbyopia is corrected by suitable convex glasses, which, by converging the rays, bring the point of near vision to eight inches. Donders found that the failure of accommodation needed to be compensated by a convex lens of one diopter for every five years of life after forty.

Astigmatism.—We have hitherto considered the dioptric surfaces as portions of true spheres. Should, however, one of the surfaces have a curve of shorter radius in one of its meridians, all the rays from a luminous point cannot be focused on the same plane, but will possess two linear foci, one anterior corresponding to the curvature of shorter radius, and the other behind corresponding to the curve of greater radius. This defect is called *astigmatism*; it is usually most marked in the cornea, and sometimes causes serious impairment of vision. It may be corrected by applying a lens ground

on a cylindrical surface in which one of the axes only is a plane ; a curve of such a radius being chosen as will enable the two linear foci to unite on the same plane.

644. **Eye-glasses. Spectacles.**—The glasses commonly used by short- or long-sighted persons are known under the general name of *eye-glasses* or *spectacles*. Generally speaking, numbers are engraved on the trial glasses which express their focal length in inches or their power in *diopeters*. This latter term is applied to the standard glasses adopted by the Ophthalmological Congress at Heidelberg, and now the only standard officially recognised throughout Europe and America. This standard is the refractive power of a lens having a focal length of a metre (39·37 inches), and is represented by the letter D. Here the refractive power is the inverse of the focal length, *i.e.* $D = \frac{1}{F}$ and $F = \frac{1}{D}$. Hence, to find the number of diopeters which represent the focal length in inches, we must divide 39·37 by that focal distance ; and, conversely, to find the focal length in inches corresponding to a given number of diopeters, we have only to divide 39·37 by this latter.

In choosing spectacles it is necessary in practice to adapt them to the special requirements of a patient rather than to correct the absolute error of refraction of the eye. The following rules, therefore, only represent the theoretical values necessary to correct the error of refraction (ametropia) present for seeing near or distant objects.

In myopia the defect is measured by the distance of the farthest point of distinct vision from the eye (*punctum remotum*) (F, fig. 633). Thus, if the punctum remotum (p.r.) be situated at 50 cm., the myopia equals $\frac{100}{50}D$, or 2 diopeters, and we correct it by a concave lens having a power = $-2D$, or a focal

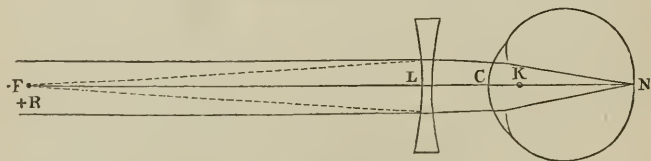

Fig. 633

length = 50 cm. For if a concave lens is placed in front of the eye, parallel rays will enter the eye as if they came from the focus of the lens, *i.e.* from the punctum remotum. But all rays from the p.r. meet on the retina, and the effect of the $-2D$ lens is to cause rays proceeding from infinity to diverge after passing through the lens as if they came from the p.r.—in other words, distant objects will appear sharply defined on the retina. A concave pair of spectacles will, therefore, be the proper correction to order. In high myopia the distance between the spectacles and the eye must be taken into account. Let the distance of the p.r. from the eye be 100 mm. = $\frac{100}{10}D$, or 10D, and let the spectacle glass be placed 13 mm. in front of the eye—the correcting glass will need to have a focal length of $100 - 13 = 87$ mm., *i.e.* a power of $\frac{100}{87}D$, or 11·5D. A concave lens of 11·5D will therefore be necessary to correct a myopia of 10D.

In hypermetropia the whole case is reversed. The retina being situated

in front of the focus, it would be necessary, in order that the image should fall on the retina, that the parallel incident rays coming from infinity should be made to converge by means of a convex lens, for convergent rays do not exist in nature. The punctum remotum in this case is therefore negative, *i.e.* it is situated behind the retina (F, fig. 634). The defect is, therefore, measured by a convex lens whose focus coincides with the punctum remotum. Parallel

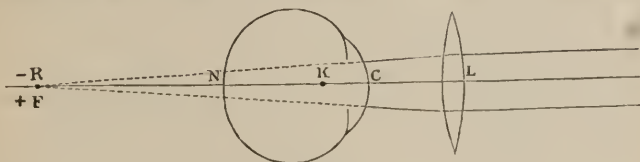

Fig. 634

rays proceeding from infinity will then enter the eye as if they came along the path of rays which converge to the p.r.—in other words, distant objects will appear sharply defined on the retina.

Suppose the p.r. be situated 125 mm. behind the eye, the hypermetropia = $\frac{1000}{125}$, *i.e.* 8D, and a lens of that refractive power will correct the error. But as the spectacles are placed about 13 mm. in front of the eye, the correcting lens will need to have a focal length of $125 + 13 = 138$ mm. or a power of about 7D. In lower degrees of hypermetropia the distance of the lens from the eye may be disregarded.

645. **Diplopia.**—*Diplopia* is an affection of the eye which causes objects to be seen double; that is, that two images are seen instead of one. Usually the two images are almost entirely superposed, and one of them is much more distinct than the other. Diplopia is usually due to a want of power in one or more of the ocular muscles, but it may be due to the prismatic action of badly centred spectacles.

646. **Achromatopsy.**—*Achromatopsy*, or *colour blindness*, is a curious defect of vision which shows itself in the inability to distinguish between certain colours which, to persons not so affected, are quite dissimilar. In other respects their vision may be quite normal. Four forms of colour blindness have been described, *viz.* *red blindness*, *green blindness*, *violet blindness*, and *total colour blindness*. By far the commonest form of this defect is that of *red blindness*. Dalton suffered from this defect, and from the fact that he very carefully described it the defect has been called *Daltonism*. Persons so affected are unable to distinguish between certain shades of red and green, being blind for two particular groups of hues which are complementary. Green or bluish green and red colours to them vary only in shade, but not in colour. Thus red cherries on a green tree are distinguishable only by their form and shade. If such a person is examined with the spectroscope the red end is found to be more or less shortened, and the whole spectrum appears to consist of two distinct colours only, yellow and blue. In many cases the two colours are separated by a neutral band of greyish colour.

Blue yellow blindness, or *violet blindness*, as it is called by some, is an exceedingly rare phenomenon. It is characterised by the inability to

distinguish blue and its shades from yellow, but red and green, with all their shades, are clearly defined. In this form the spectrum is shortened at the violet end. *Green blindness* has also been described, but as in colour blindness the complementary colours are always defective, it is difficult to distinguish such cases from red blindness, and what appears to be green blindness by one test may be considered to be red blindness by another.

Total colour blindness.—Lastly, cases have been occasionally met with in which all sensation of colour is absent, the spectrum appearing to such persons as a greyish band of varying brightness. In such cases the vision will be somewhat impaired as well.

Colour blindness occurs chiefly in the male sex. It is usually congenital, and is found to affect from 3 to 4 per cent. of the community. When acquired it is almost always due to disease. Owing to the danger which may arise from the faulty observation of coloured signals on railways and at sea, numerous methods have been proposed for the qualitative and quantitative observation of the colour sense.

The best test for ordinary use is to give the patient a standard skein of wool of a particular tint, green, rose, or red, and to require him to match it with others which appear to him of the same tint, among a large bundle of skeins of many colours. Coloured glasses which can be rotated in front of a lantern to imitate railway signals are also largely used for this purpose.

647. **Ophthalmoscope.**—This instrument, as its name indicates, is designed for the examination of the eye, and was invented in 1851 by Von Helmholtz. It consists:—1. Of a concave spherical reflector of glass or metal, M (figs. 635, 636), in the middle of which is a small hole about a sixth of an inch in diameter. The focal length of the reflector is from 8 to 10 inches. 2. Of a converging lens, *o*, which is held in front of the eye of the patient.

To make use of the ophthalmoscope, the patient is placed in a dark room,

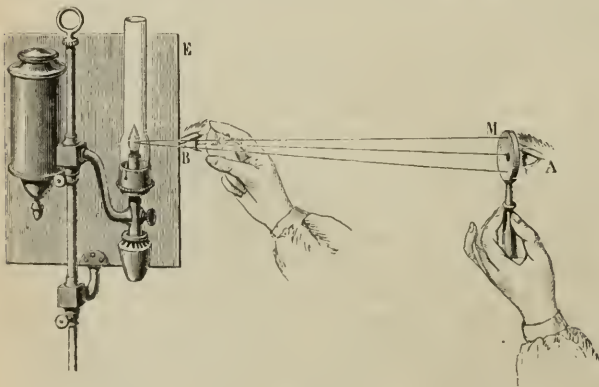

Fig. 635

and a lamp put beside him, E. The screen serves to shade the light from his head, and keep it in darkness. The observer, A, holding in one hand the reflector, employs it to concentrate the light of the lamp near the eye, B, of the

patient, and with his other hand holds the achromatic lens, *o*, in front of the eye. By this arrangement the back of the eye is lighted up, and its structure can be clearly discerned.

Fig. 636 shows how the image of the back of the eye is produced, which the observer, A, sees on looking through the hole in the reflector. Let ab be the part of the retina on which the light is concentrated, pencils of rays proceeding from ab would form an inverted and aerial image of ab at $a'b'$. These pencils, however, on leaving the eye, pass through the lens o , and thus the image $a''b''$ is in fact formed, inverted, but distinct, and in a position fit for vision.

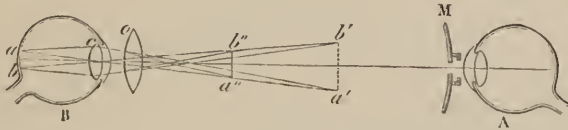

Fig. 636

Modern ophthalmoscopes are now usually provided with either one or more discs of metal carrying a complete series of convex and concave lenses, or with a similar series of lenses forming a chain of discs fitted in the body of the instrument. These lenses are so arranged that the observer by rotating a small wheel can bring a lens of any focal length he pleases behind the aperture of the mirror. This mirror is usually of a much shorter focal length than in the instrument previously described, and is tilted at an angle so that its plane is not parallel to the lenses behind the mirror. In consequence of this, the ophthalmoscope can be held almost touching the patient's eye, while the light can still be reflected into the eye from the mirror. In this form of ophthalmoscope the lens o is dispensed with, and by placing behind the mirror the lens which corrects the sum (or difference) of the refractive errors of the patient's and the observer's eye, the observer's eye is rendered emmetropic for the pencils of light which reach it. In this case the rays of light from the lamp are reflected from the mirror directly on the back of the patient's eye, and proceeding from ab , are converged by the lens placed behind the mirror in such a manner that they form an erect image enlarged about twenty times, while in the former indirect method the image is inverted and enlarged only about four or five times. By a simple contrivance in the form of a swivel carrying the two kinds of mirrors, either can be at once rotated in front of the aperture, and thus the same instrument can be employed for both methods of examination. The direct method just described affords a ready means of estimating the refraction of the patient's eye, or, in other words, of ascertaining at once the focal length of the lens necessary to enable the patient to see distant objects. To find this, all that is necessary is that the observer should previously ascertain the exact number of diopters necessary to correct his eye for distant vision, and to accustom himself to relax his accommodation to the full when using the instrument. On the patient's part this relaxation occurs insensibly. The eye of both persons being adjusted for distant objects, the observer now looks through the aperture of the mirror, holding the instrument as close to the patient's eye as possible. Should both eyes be emmetropic (normal), the rays of light which are practically parallel would be focused on the

retinae of both the eyes, and no correcting lens would be needed. Should the observer's eye be at fault, the lens which will correct it for parallel rays will enable him to see the details of the patient's retina. Should both eyes want correcting, then the number of diopters which are found necessary to add to or subtract from the number which correct the observer's eye will indicate the error in the patient's eye. By thus correcting for the vessels in the retina which run in every direction, both the axis and the amount of astigmatism present may be readily ascertained.

CHAPTER VII

SOURCES OF LIGHT. PHOSPHORESCENCE

648. **Various sources of light.**—The various sources of light are the sun, the stars, heat, chemical combination, phosphorescence, electricity, and meteoric phenomena. The last two sources will be treated under the articles Electricity and Meteorology.

The origin of the light emitted by the sun and by the stars is unknown ; the sun is the chief source ; its temperature is estimated at hundreds of thousands of degrees. The ignited envelope by which the sun is surrounded is gaseous, because the light of the sun, like that emitted from all gaseous bodies, gives no trace of polarisation in the polarising telescope (chap. viii.).

Terrestrial bodies become sources of light when they are raised to a sufficiently high temperature ; according to Draper all bodies begin to glow with a red heat at 525° , or according to more recent observers at about 490° C. ; the light is brighter as the temperature is higher, and at 1170° a body is white-hot.

The luminous effects witnessed in many chemical combinations are due to the high temperatures produced. Ordinary luminous flames are essentially gases containing solids heated to incandescence.

649. **Phosphorescence.**—Certain bodies have the property of becoming luminous in the dark without any considerable rise of temperature. This phenomenon, which is well seen in phosphorus, is for this reason known as *phosphorescence*. Here it is undoubtedly due to a slow oxidation, for it ceases in spaces where no oxygen is present. Phosphorescence is also exhibited under certain conditions by decaying animal and vegetable matter. This is also due to slow oxidation.

Phosphorescence is observed in living animals, of which the best known case is that of the *glowworm* ; here it is very intense, and the brightness seems to depend on the will. Its light consists of a continuous spectrum from C to near H, and is particularly rich in blue and green rays. In tropical climates the sea is often covered with a bright phosphorescent light due to myriads of small luminous infusoria (*Noctiluca miliaris*).

Langley showed that in ordinary oil or gas flames more than 99 per cent. of the total energy is expended as heat, and is lost as regards light ; and in sources at a high temperature, such as the arc and incandescent electric lights, the proportion although less is still considerable. The light of the fire-fly (*Pyrophorus noctilucus*), which is found abundantly in Cuba, when examined by the spectroscope and bolometer is found to be devoid of red and infra-red rays, that is, to contain only luminous rays. It thus represents an

economical form of light. As the more refrangible rays are those which affect the eye, it is desirable to obtain as much energy in this form as possible, and it is in this direction that improvement in artificial illumination is to be looked for. At present, to use the striking comparison of Sir Oliver Lodge, we are in the position of an organist who, in order to produce a few very high notes of the organ, has to turn on the whole of the register.

Phosphorescence by rise of temperature. This is best seen in certain species of diamonds, and particularly in *chlorophane*, a variety of fluorspar, which, when heated to 300° or 400° , suddenly becomes luminous, emitting a greenish-blue light which lasts for several days.

Hagenbach examined the spectrum of phosphorescent fluorspar, and found that it consisted of only nine bands: four blue, two green, two yellow, and one orange. As the relative intensities of these bands are continually changing, it is easy to understand the different colours presented by different specimens of this mineral.

Phosphorescence by mechanical effects, such as friction, percussion, cleavage, &c.; for example, when two crystals of quartz are rubbed against each other in darkness, when a lump of sugar is broken, or when a plate of mica is cleft. To this category belongs also the disengagement of light when arsenious acid crystallises.

Phosphorescence by electricity, like that which results from the friction of mercury against the glass in a barometric tube.

650. Phosphorescence by insolation.—A large number of substances, after having been exposed to the direct action of sunlight, or even of the diffused light of the atmosphere, emit in darkness a phosphorescence the colour and intensity of which depend on the nature and physical condition of these substances.

This was first observed in 1604 in *Bolognese phosphorus* (barium sulphide), but it also exists in a great number of substances. Calcium and strontium sulphides are those which present it in the highest degree. They must be prepared in the dry way and at high temperatures. When well prepared, after being exposed to the light, they are luminous for several hours in darkness. But as this phosphorescence takes place in a vacuum as well as in a gaseous medium, it cannot be attributed to a chemical action, but rather to a temporary modification which the body undergoes from the action of light. A phosphorescent calcium sulphide is prepared for industrial purposes, and is known as *Balmain's luminous paint*.

After the substances above named, the best phosphorescents are the following, in the order in which they are placed: a large number of diamonds (especially yellow ones), and most specimens of fluorspar; then arragonite, calcareous concretions, chalk, apatite, heavy spar, dried calcium nitrate and dried calcium chloride, calcium cyanide, a large number of strontium or barium compounds, magnesium and its carbonate, &c. Besides these a large number of organic substances also become phosphorescent by insolation; for instance, dry paper, silk, cane-sugar, milk-sugar, amber, the teeth, &c. Dewar has shown that at -180° C. all substances are phosphorescent.

The different spectral rays are not equally well fitted to render substances phosphorescent. The maximum effect takes place in the violet rays, or even

a little beyond ; while the light emitted by phosphorescent bodies generally corresponds to rays of a smaller refrangibility, that is, of greater wave-length, than those of the light received by them and giving rise to the action.

The tint which phosphorescent bodies assume is very variable, and even in the same body it changes with the manner in which it is prepared. In strontium compounds green and blue tints predominate ; and orange, yellow, and green tints in the barium sulphides.

The duration of phosphorescence varies also in different bodies. In calcium and strontium sulphides, phosphorescence lasts as long as thirty hours : with other substances it does not exceed a few seconds, or even a fraction of a second.

The colour emitted by an artificial phosphorescent alters with the temperature during insolation. Thus with strontium sulphide the light is dark violet at -20° C., bright blue at $+40^{\circ}$, bluish-green at 70° , greenish-yellow at 100° , and reddish-yellow of feeble luminosity at 200° C.

When a phosphorescent body has been heated the light emitted is brighter but the greater the emission of light the shorter is the duration of the phosphorescence. Heat, therefore, produces a more rapid radiation of the light

Phosphoroscope. In experimenting with bodies whose phosphorescence lasts a few minutes or even a few seconds, it is simply necessary to expose them to solar or diffused light for a short time, and then place them in darkness : their luminosity is very apparent, especially if care has been taken to close the eyes previously for a few moments. But in the case of bodies whose phosphorescence lasts only a very short time, this method is inadequate. Becquerel invented an ingenious apparatus, the *phosphoroscope*, by which bodies can be viewed immediately after being exposed to light : the interval which separates the insolation and observation can be made as small as possible, and can be measured with great precision.

This apparatus consists of a closed cylindrical box, AB (fig. 637), of blackened metal ; on the ends are two apertures opposite each other which have the form of a circular sector. One only of these, α , is seen in the figure. The box is fixed, but it is traversed in the centre by a movable axis, to which are fixed two circular screens, MM and PP, of blackened metal (fig. 638). Each of these screens is perforated by four apertures of the same shape as those in the box ; but while the latter correspond to each other, the apertures of the screens alternate, so that the open parts of the one correspond to the closed parts of the other. The two screens, as already mentioned, are placed in the box, and fixed to the axis, which by means of a train of wheels, worked by a handle, can be made to turn with any velocity.

In order to investigate the phosphorescence of any body by means of this instrument, the body is placed on a stirrup interposed between the two rotating screens. The light cannot pass simultaneously through the opposite apertures of the sides A and B, because one of the closed parts of the screen MM, or of the screen PP, is always between them. So that when a body, α , is illuminated by light from the other side of the apparatus, it could not be seen by an observer looking at the aperture, α , for then it would be masked by the screen PP. Accordingly, when an observer saw the body α , it would not be illuminated, as the light would be intercepted by the closed

parts of a screen MM. The body *a* would alternately appear and disappear ; it would disappear during the time of its being illuminated, and appear when it was no longer so. The time which elapses between the appearance and disappearance depends on the velocity of rotation of the screens. Suppose,

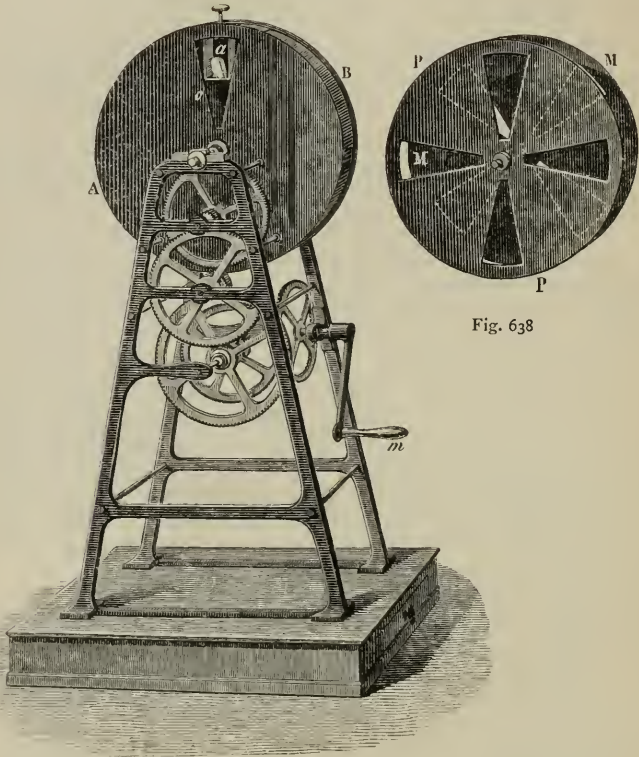

Fig. 637

Fig. 638

for instance, that they made 150 turns in a second ; as one revolution of the screens is effected in $\frac{1}{150}$ of a second, there would be four appearances and four disappearances during that time. Hence the length of time elapsing between the time of illumination and of observation would be $\frac{1}{4}$ of $\frac{1}{150}$ of a second, or 0.0008 of a second.

Observations with the phosphoscope are made in a dark chamber, the observer being on that side on which is the wheelwork. A ray of solar or electric light is allowed to fall upon the substance *a*, and, the screens being made to rotate more or less rapidly, the body *a* appears luminous in a continuous manner, when the interval between insolation and observation is less than the duration of the phosphorescence of the body. By experiments of

this kind, Becquerel found that substances which usually are not phosphorescent appear so in the phosphoroscope ; such, for instance, as Iceland spar. Uranium compounds present the most brilliant appearance in this apparatus ; they emit a very bright luminosity when the observer can view them 0.03 or 0.04 of a second after insolation. But a large number of bodies produce no effect in the phosphoroscope ; for instance, quartz, sulphur, phosphorus, metals, and liquids.

CHAPTER VIII

DOUBLE REFRACTION. INTERFERENCE. POLARISATION

651. **The undulatory theory of light.**—It has been already stated (510) that the phenomenon of light is ascribed to waves or undulations propagated through an exceedingly rare medium called the luminiferous ether, which is supposed to pervade all space, and to exist between the molecules of the ordinary forms of matter. It is held, in short, that light is due to undulations of the ether, just as sound is due to undulations propagated through the air. In the latter case, the undulations cause the drum of the ear to vibrate and produce the sensation of sound. In the former case, the undulations cause points of the retina to vibrate and produce the sensation of light. The two cases differ in this, that in the case of sound there is independent evidence of the existence and vibration of the medium (air) which propagates the undulation; whereas in the case of light the existence of the medium and its vibrations is *assumed*, because that supposition connects and explains in the most complete manner a long series of very various phenomena. There is, however, no independent evidence of the existence of the luminiferous ether.

The analogy between the phenomena of sound and light is very close; thus, the intensity of a sound is greater as the amplitude of the vibration of each particle of the air is greater, and the intensity of light is greater as the amplitude of the vibration of each particle of the ether is greater. Again, a sound is more acute as the length of each undulation producing the sound is less, or, what comes to the same thing, according as the number of vibrations per second is greater. In like manner, the colour of light is different according to the length of the undulation producing the light: a red light is due to a comparatively long undulation, and corresponds to a deep sound, while a violet light is due to a short undulation, and corresponds to an acute sound.

Although the wave-length cannot be observed directly, yet it can be inferred from certain phenomena with great exactness. The following table gives the lengths, in inches and millimetres, of the undulations corresponding to the light at the principal dark lines of the spectrum:—

Dark line	Wave-length in inches	Wave-length in millimetres
A	0·0000299	0·0007504
B	0·0000271	0·0006874
C	0·0000258	0·0006562
D	0·0000232	0·0005897
E	0·0000207	0·0005271
F	0·0000191	0·0004862
G	0·0000169	0·0004311
H	0·0000159	0·0003969

It will be remarked that the limits are very narrow within which the lengths of the undulations of the ether must be comprised, if they are to be capable of producing the sensation of light. In this respect light is in marked contrast to sound. For the limits are very wide within which the lengths of the undulations of the air may be comprised when they produce the sensation of sound (244).

The colour of a body is due to the power it has of absorbing certain vibrations, and of reflecting others; and the body appears of the colour produced by the coexistence of the reflected vibrations. A body appears white when it reflects all different vibrations in the proportion in which they are present in the spectrum; it appears black when it reflects light in such small quantities as not to affect the eye. A red body is one which has the property of reflecting in predominant strength those vibrations which produce the sensation of red. This is seen in the fact that, when a piece of red paper is held against the daylight, and the reflected light is caught on a white wall, this also appears red. A piece of red paper in the red part of the spectrum appears of a brighter red, and a piece of blue paper held in the blue part appears a brighter blue; while a red paper placed in the violet or blue part appears almost black. In the last case the red paper can only reflect red rays, while it extinguishes the blue rays, and as the blue of the spectrum is almost free from red, so little is reflected that the paper appears black.

When light falls upon a transparent body, the body appears colourless if all the vibrations are transmitted in the proportion in which they exist in the spectrum. But if some of the vibrations are checked or extinguished, the emergent light will be of the colour produced by the coexistence of the unchecked vibrations. Thus, when a piece of blue glass is held before the eye, the vibrations producing red and yellow are extinguished, and the colour is due to the emergent vibrations which produce blue light.

The undulatory theory also accounts for the reflection and refraction of light, as well as other phenomena which are yet to be described. The explanation of the refraction of light is of so much importance that we shall devote to it the next article.

652. **Physical explanation of single refraction.**—The explanation of this phenomenon by means of the undulatory theory of light presupposes that of the mode of propagation of a plane wave. Now, if a disturbance originated at any *point* of the ether, it would be propagated as a spherical wave in all directions round that point with a uniform velocity. If, instead of a single point, we consider the front of a plane wave, it is evident that disturbances originate simultaneously at all points of the front, and that spherical waves proceed from each *point* with the same uniform velocity. Consequently, all these spheres will at any subsequent instant be touched by a plane parallel to the original plane. The disturbances propagated from the points in the first position of the wave will mutually destroy each other, except in the tangent plane; consequently the wave advances as a plane wave, its successive positions being the successive positions of the tangent plane. If the wave moves in any medium with a velocity v , it will describe a space vt in a time t , in a direction at right angles to the wave-front,

In any given moment let mn (fig. 639) be the position of the wave-front of a beam of light, which, moving through any medium, meets the plane surface

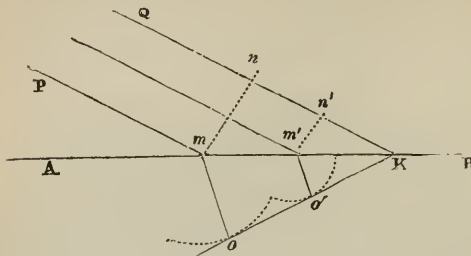

Fig. 639

AB of any denser refracting medium. In the same moment in which the wave-front reaches n , m becomes the centre of a spherical wave system which moves in the second medium; and, as the elasticity of the second medium is different from that of the first, the velocities of propagation of the

wave in the two media will be different. While the plane wave moves from n to K , the corresponding wave starting from m reaches the surface of a sphere the radius of which is less than nK , if the second medium is denser than the first. The incident wave in like manner reaches m' and n' simultaneously, and while n' moves to K , m' moves to o' on the surface of a sphere, the radius of which, $m'o'$, is to mo as $n'K$ is to nK . All the elementary waves proceeding from points intermediate to n and K which arise from the same incident wave, touch one and the same plane $Ko'o$, and the refracted ray proceeds in the new medium perpendicular to this tangent plane.

Now nK and mo are proportional to the velocities of light in the two media respectively; let mK be taken as unit of length, then

$$nK = \sin nmK \text{ and } mo = \sin mKo.$$

Now nmK is the angle of incidence of the ray, and mKo is the angle of refraction, and nK and mo are proportional to the velocities of light in the two media respectively; hence we see that these velocities are to each other in the same ratio as the sines of the angles of incidence and refraction; a conclusion which agrees with the results of direct observation (517), and forms a beautiful confirmation of the truth of the undulatory theory.

DOUBLE REFRACTION

653. **Double refraction.**—It has been already stated (545) that a large number of crystals possess the property of double refraction, in virtue of which a single incident ray in passing through any one of them is divided into two, or undergoes *bifurcation*, whence it follows that, when an object is seen through one of these crystals, it appears double. The fact of the existence of double refraction in Iceland spar was first stated by Bartholin in 1669, but the law of double refraction was first enunciated exactly by Huyghens in his treatise on light, written in 1678 and published in 1690.

Crystals which possess this peculiarity are said to be *double-refracting*. It is found to a greater or less extent in all crystals which do not belong to the cubical system. Bodies which crystallise in this system, and those which, like glass, are destitute of crystallisation, have no double refraction. The property can, however, be imparted to them when they are unequally compressed, or when they are cooled quickly after having been heated, in

which state glass is said to be *unannealed*. Of all substances, that which possesses it most remarkably is Iceland spar or crystallised calcium carbonate. In many substances, the power of double refraction can hardly be proved to exist directly by the bifurcation of an incident ray; but its existence is shown indirectly by their action on polarised light (677).

Fresnel explained double refraction by assuming that the ether in double-refracting bodies is not equally elastic in all directions; from which it follows that the vibrations, in certain directions at right angles to each other, are transmitted with unequal velocities; these directions being dependent on the constitution of the crystal. This hypothesis is confirmed by the property which glass acquires of becoming double-refracting by pressure and when unannealed.

654. Uniaxial crystals.—In all double-refracting crystals there is *one* direction, and in some a second direction, possessing the following property:—When a point is looked at through the crystal in this particular direction, it does *not* appear double. The lines fixing these directions are called *optic axes*; and sometimes, though not very properly, axes of double refraction. A crystal is called *uniaxial* when it has *one* optic axis; that is to say, when there is one direction within the crystal along which a ray of light can proceed without bifurcation. When a crystal has *two* such axes, it is called a *biaxial* crystal.

The uniaxial crystals most frequently used in optical instruments are Iceland spar, quartz, and tourmaline. Iceland spar crystallises in rhombohedra, whose faces form with each other angles of $105^{\circ} 5'$ or $74^{\circ} 55'$. It has eight solid angles (see fig. 640). Of these, two, situated at the extremities of one of the diagonals, are severally contained by three obtuse angles. A line drawn within one of these two angles in such a manner as to be equally inclined to the three edges containing the angle is called the *axis of the crystal*. If all the edges of the crystal were equal, the axis of the crystal would coincide with the diagonal, *ab*.

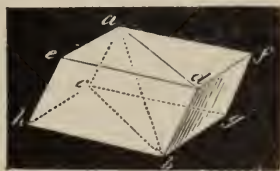

Fig. 640

Brewster showed that in all uniaxial crystals the optic axis coincides with the axis of crystallisation.

The principal plane with reference to a point of any face of a crystal, whether natural or artificial, is a plane drawn through that point at right angles to the face and parallel to the optic axis. If in fig. 640 we suppose the edges of the rhombohedron to be equal, the diagonal plane *acbd* contains the optic axis (*ab*), and is at right angles to the faces *acdf* and *chbg*; consequently it is parallel to the principal plane at any point of either of those two faces. For this reason *acbd* is often called the principal plane with respect to those faces; any plane parallel to this is also a principal plane.

655. Ordinary and extraordinary ray.—One of the two rays into which an incident ray is divided on entering a uniaxial crystal is called the *ordinary*, and the other the *extraordinary* ray. The ordinary ray follows the laws of single refraction; that is, with respect to that ray the sine of the angle of incidence bears a constant ratio to the sine of the angle of refraction, and the plane of incidence coincides with the plane of refraction. Except in

particular positions, the extraordinary ray follows neither of these laws. The images corresponding to the ordinary and extraordinary rays are called the ordinary and extraordinary images respectively.

If a transparent specimen of Iceland spar is placed over a dot of ink, on a sheet of white paper, two images will be seen. One of them, the ordinary image, will seem slightly nearer to the eye than the other, the extraordinary image. Suppose the spectator to view the dot in a direction at right angles to the paper, then, if the crystal, with the face still on the paper, is turned round, the *ordinary* image will continue fixed, and the *extraordinary* image will describe a circle round it, the line joining them being always in the direction of the shorter diagonal of the face of the crystal, supposing its edges to be of equal length. In this case it is found that the angle between the ordinary and extraordinary ray is $6^{\circ} 12'$.

656. **The laws of double refraction in a uniaxial crystal.**—These phenomena are found to obey the following laws :—

i. Whatever be the plane of incidence, the ordinary ray always obeys the two general laws of single refraction (546). The refractive index for the ordinary ray is called the ordinary refractive index.

ii. In every section perpendicular to the optic axis the extraordinary ray also follows the laws of single refraction. Consequently, in this plane, the extraordinary ray has a constant refractive index, which is called the extraordinary refractive index.

iii. In every principal section the extraordinary ray follows the second law only of single refraction ; that is, the planes of incidence and refraction coincide, but the ratio of the sines of the angles of incidence and refraction is not constant.

Huyghens gave a very simple geometrical construction, by means of which the directions of the refracted rays can be determined when the directions of the incident ray and of the axis are known relatively to the face of the crystal. This construction was not generally accepted by physicists until Wollaston, and subsequently Malus, showed its truth by numerous exact measurements.

657. **Positive and negative uniaxial crystal.**—The term extraordinary refractive index has been defined in the last article. For the same crystal, its magnitude always differs from that of the *ordinary* refractive index ; for example, in Iceland spar the ordinary refractive index is 1.654, while the extraordinary refractive index is 1.483. In this case the ordinary index exceeds the extraordinary index. When this is the case the crystal is said to be negative. On the other hand, when the extraordinary index exceeds the ordinary index, the crystal is said to be positive. The following list gives the names of some of the principal uniaxial crystals :—

Negative Uniaxial Crystals

Iceland spar	Ruby	Pyromorphite
Tourmaline	Emerald	Potassium ferrocyanide
Sapphire	Apatite	Sodium nitrate

Positive Uniaxial Crystals

Zircon	Apophyllite	Titanite
Quartz	Ice	Boracite

658. **Double refraction in biaxial crystals.**—A large number of crystals, including all those belonging to the *trimetric*, the *monoclinic*, and the *triclinic* systems, possess two *optic axes*; in other words, in each of these crystals there are two directions along which a ray of light passes without bifurcation. A line bisecting the acute angle between the optic axes is called the *medial line*; one that bisects the obtuse angle is called the *supplementary line*. It has been found that the medial and supplementary lines and a third line at right angles to both are closely related to the fundamental form of the crystal to which the optic axes belong. The acute angle between the optic axes is different in different crystals. The following table gives the magnitude of this angle in the case of certain crystals:—

Nitre	5° 20'	Mica	45° 0'
Strontianite	6 56	Sugar	50 0
Arragonite	18 18	Selenite	60 0
Anhydrite	28 7	Epidote	84 19
Heavy spar	37 42	Iron sulphate	90 0

When a ray of light enters a biaxial crystal, and passes in any direction not coinciding with an optic axis, it bifurcates; in this case, however, neither ray conforms to the laws of single refraction, but both are extraordinary rays. To this general statement the following exception must be made:—In a section of a crystal at right angles to the medial line one ray follows the laws of ordinary refraction, and in a section at right angles to the supplementary line the other ray follows the laws of ordinary refraction.

INTERFERENCE AND DIFFRACTION

659. **Interference of light.**—The name *interference* is given to the reciprocal action which two rays of light exert upon each other when they are emitted from two neighbouring sources, and meet each other under a very small angle. This action may be observed by means of the following experiment:—In the shutter of a dark room two very small apertures of the same diameter are made close to each other. The apertures are closed by pieces of coloured glass—red, for example—by which two pencils of homogeneous light are introduced. These two pencils form two divergent luminous cones which meet at a certain distance; they are received on a white screen a little beyond the place at which they meet, and in the segment common to the two discs which form upon this screen some very well-defined alternations of red and black bands are seen. If one of the two apertures is closed, the fringes disappear, and are replaced by an almost uniform red tint. From the fact that the dark fringes disappear when one of the beams is intercepted, it is concluded that they arise from the interference of the two pencils which cross obliquely.

This experiment was first made by Grimaldi, but was modified by Young. Grimaldi had drawn from it the conclusion that light added to light may produce darkness. The full importance of this principle remained for a long time unrecognised, until these inquiries were resumed by Young and by Fresnel, of whom the latter, by a modification of Grimaldi's experiment, rendered it an *experimentum crucis* of the truth of the undulatory hypothesis.

In Grimaldi's experiment diffraction (660) takes place, for the luminous rays pass by the edge of the aperture. In the following experiment, which is due to Fresnel, the two pencils interfere without the possibility of diffraction.

Two plane mirrors, AB and BC (fig. 641), of metal, are arranged close to each other, so as to form a very obtuse angle, ABC, which must be very little

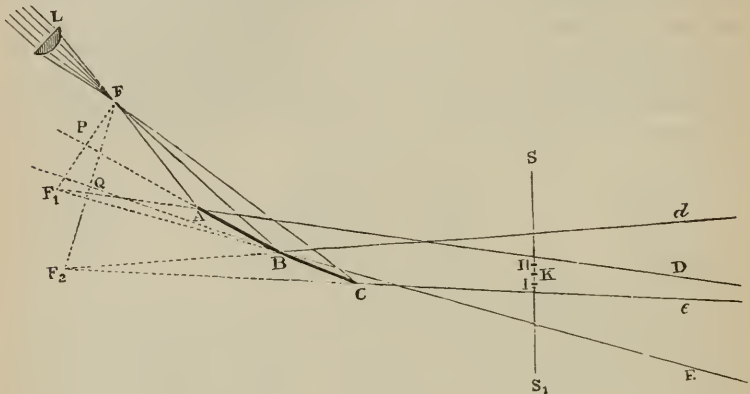

Fig. 641

less than 180° . A pencil of monochromatic light—red, for instance—which passes into the dark chamber, is brought to a focus, F, by means of a lens, L. On diverging from F the rays fall partly on AB, and partly on BC. If BA is produced to P and FPF_1 is drawn at right angles to AP, and if PF_1 is made equal to PF, then the rays which fall on AB will, after reflection, proceed as if they diverged from F_1 . If a similar construction is made for the rays falling on BC, they will proceed after reflection as if they diverged from F_2 . A little consideration will show that F_1 and F_2 are very near each other. Suppose the reflected rays to fall on a screen SS_1 placed nearly at right angles to their directions. Every point of the screen which receives light from both pencils is illuminated by both rays, viz. one from F_1 , the other from F_2 : thus the point H is illuminated by two rays, as also are K and I.

Now the combined action of these two pencils is to form a series of parallel bands alternately red and black on the screen (fig. 642). They are distributed symmetrically in reference to one of them cc , which is more brilliant than the others, and which is

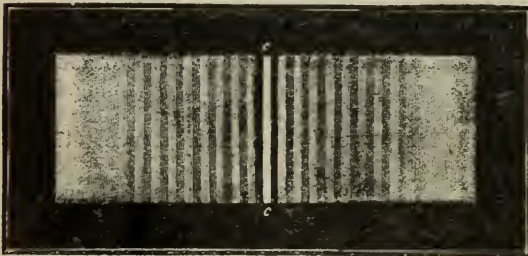

Fig. 642

called the central fringe. This is the fundamental phenomenon of interference; and that it results from the *joint action of the two pencils* is plain,

for if the light which falls upon either of the mirrors is cut off, the dark bands altogether disappear.

The experiment may also be made by means of *Ohm's prism* or the bi-prism, which is a prism in which the refracting angle is very nearly 180° .

A very simple arrangement of a mirror for experiments on the interference of light is thus constructed. Four small wax pellets, *a*, *b*, *c*, *d*, are placed on a small block of wood, and on this two strips of plate glass, which accurately fit along the line *bc* (fig. 643). A larger glass plate is then laid on this, and the finger moved with gentle pressure along this line. In this way the two mirrors form a very slight angle with each other, and give in sunlight the coloured fringes.

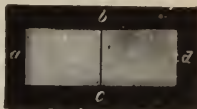

Fig. 643

The above remarkable experiment is explained in the most satisfactory manner by the undulatory theory of light. The explanation exactly resembles that already given of the formation of nodes and loops by the combined action of two aerial waves (262); the only difference being that in that case the vibrating particles were supposed to be particles of air, whereas in the present case the vibrating particles are supposed to be those of the luminiferous ether. Consider any point *K* (fig. 641) on the screen, and first let us suppose the distance of *K* from F_1 and F_2 to be equal. Then the undulations which reach *K* will always be in the same *phase*, and the particle of ether at *K* will vibrate as if the light came from one source: the amplitude of the vibration, however, will be increased in exactly the same manner as happens at a loop or ventral point; consequently, at *K* the intensity of the light will be increased. The same will be true for all points on the screen, such that the difference between their distances from the two images equals the length of *one, two, three, &c.*, undulations. If, on the other hand, the distances of *K* from F_1 and F_2 differ by the length of half an undulation, then the two waves would reach *K* in exactly opposite phases. Consequently, whatever velocity would be communicated at any instant to a particle of ether by the one undulation, an exactly equal and opposite velocity would be communicated by the other undulation, and the particle would be *permanently* at rest, or there would be darkness at that point; this result being produced in a manner precisely resembling the formation of a *nodal* point already explained. The same will be true for any position of *K* which is such that the difference between its distances from F_1 and F_2 is equal to three halves, or five halves, or seven halves, &c., of an undulation. Accordingly, there will be on the screen a succession of alternations of light and dark points, or rather lines—for what is true of points in the plane of the paper (fig. 642) will be equally true of other points on the screen, which is supposed to be at right angles to the plane of the paper. Between the light and dark lines the intensity of the light will vary, increasing gradually from darkness to its greatest intensity, and then decreasing to the second dark line, and so on.

If instead of red light any other coloured light were used—for example, violet light—an exactly similar phenomenon would be produced, but the distance from one dark line to another would be less than before. If white light is used, each separate colour tends to produce a different set of dark lines. Now these sets being superimposed on each other and not coinciding, the

dark lines due to one colour are illuminated by other colours, and instead of dark lines a succession of coloured bands is produced. The number of coloured bands produced by white light is much smaller than the number of dark lines produced by a homogeneous light ; since at a small distance from the middle band the various colours are completely blended, and a uniform white light produced.

660. **Diffraction and fringes.**—Diffraction is a modification which light undergoes when it passes the edge of a body, or when it traverses a small aperture—a modification in virtue of which the luminous rays appear to become bent, and to penetrate into the shadow.

This phenomenon may be observed in the following manner :—A beam of sunlight is allowed to pass through a very small aperture in the shutter of a dark room, where it is received on a condensing lens, *L* (fig. 644), with a



Fig. 644

short focal length. A red glass is placed in the aperture so as to allow only red light to pass. An opaque screen, *c*, with a sharp edge *a*—a razor, for instance—is placed behind the lens beyond its focus, and intercepts one portion of the luminous cone, while the other is projected on the screen *b*, of which *B* represents a front view. The following phenomena are now seen :—Within the geometrical shadow, the limit of which is represented by the line *ab*, a faint light is seen, which gradually fades in proportion as it is farther from the limits of the shadow. In the upper part of the screen—which, being above the line *ab*, might be expected to be uniformly illuminated—a series of alternate dark and light bands or fringes is seen parallel to the line of shadow, which gradually become more indistinct and ultimately disappear. The limits between the light and dark fringes are not quite sharp lines : there are parts of maximum and minimum intensity which gradually fade off into each other.

All the colours of the spectrum give rise to the same phenomenon, but the fringes are broader in proportion as the light is less refrangible. Thus with red light they are broader than with green, and with green than with violet. Hence, with white light, which is composed of different colours, the dark spaces of one tint overlap the light spaces of another, and thus a series of prismatic colours will be produced.

If, instead of placing the edge of an opaque body between the light and the screen, a very narrow body be interposed, such as a hair or a fine metal wire, the phenomena will be different. Outside the space corresponding to the geometrical shadow, there is a series of fringes, as in the former case. But within the shadow also there is a series of alternate light and dark bands. They are called interior fringes, and are much narrower and more numerous than the external fringes.

When a small opaque circular disc is interposed, white light being used, its shadow on the screen shows in the middle a bright spot surrounded by a series of coloured concentric rings; the bright spot is of various colours according to the relative positions of the disc and screen. The haloes sometimes seen round the sun and moon belong to this class of phenomena. They are due, as Fraunhofer showed, to the diffraction of light by small globules of fog in the atmosphere. Fraunhofer even gave a method of estimating the mean diameter of these globules from the dimensions of the haloes.

661. **Gratings.**—Phenomena of diffraction of another class are produced by allowing the pencil of light from the luminous point to traverse an aperture in the form of a narrow slit in an opaque screen. The diffracted light

may be received on a sheet of white paper, but the images are much better seen through a small telescope placed behind the aperture. If the aperture is very small, the telescope may be dispensed with, and the figure may be viewed by placing the aperture before the eye. If now



Fig. 645

monochromatic light (583)—red, for instance—is allowed to fall through such a narrow slit, a bright band of red light is seen, and right and left of it a series of similar bands gradually diminishing in brightness and separated by dark bands.

The breadth of these bands differs with the nature of the light, being narrower and nearer together in violet than in green, and these again narrower and nearer than in red, as shown in fig. 645. If ordinary white light is used, then the colours are not exactly superposed, but a series of equidistant spectra is formed on each side of the bright line, with their violet side turned inwards.

In order to explain this let us refer to fig. 646, which represents the formation of the first dark band. When light is incident on the slit, AB, the particles of ether there, which we will represent by the dotted lines, will be set in vibration, and each point will become the centre of a new series of oscillations. Consider now the undulations which constitute a ray proceeding at right angles to the plane of the slit: all such undulations will form a band of light on the screen MN. Those which are not parallel but proceed at equal inclinations, and meet at the point r , will be in the same phase and will reinforce each other, and the line of maximum brightness will be at r . Consider, however, a pencil of rays which proceeds

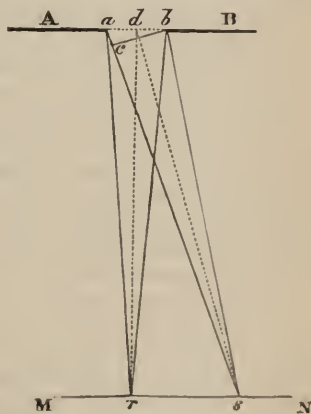

Fig. 646

from the slit in an oblique direction and which meets the screen, or the retina, in the point s , and let us suppose that the difference between the lengths of the paths of the undulations proceeding from the edges b and a —that is, bs and as —is equal to the length of an undulation. Make $sc = sb$ and join bc ; then ac is the length of the undulation.

Let us suppose that the whole set of undulations which proceeds from the slit ab is divided at d into two equal groups of undulations. Then a little consideration will show that at any part of the path there will be a difference of phase of half an undulation between the ray from the margin a , and that from the centre d ; and to each of the undulations constituting the group on the left there will be a corresponding one among the groups on the right, which just differs from it by half an undulation; the general effect will be that the group on the left will be half a wave-length behind the group on the right, and the two arriving at the screen in opposite phases neutralise each other and produce darkness.

When the difference between the paths of the marginal undulations is equal to half a wave-length, a partial destruction of light takes place; the luminous intensity corresponding to this obliquity is a little less than half that of the undiffracted light. If the marginal distance is one and a half undulations, we can, as before, conceive the whole pencil divided into three parts, of which two will neutralise each other, and the third only will be effective. There will be a luminous band, but one of less intensity. In like manner where the marginal undulations differ by two whole wave-lengths they will again extinguish each other, and a dark band will be the result. Thus there will be formed a series of alternate dark and bright bands of rapidly diminishing intensity. In general, when the difference of path of the rays proceeding from the margin of the slit amounts to n wave-lengths, n being any whole number, we have a dark band, and when it amounts to $n + \frac{1}{2}$ wave-lengths, a bright band.

The phenomena of diffraction produced when other than straight lines are used are often of great beauty. They were more particularly examined by Scherdt, and the whole of the phenomena are in exact accordance with the undulatory theory, though the explanation is in many cases somewhat intricate. The theory renders it possible to predict the appearance which any particular aperture will produce, just as astronomy enables us to foretell the motions of the heavenly bodies. Some of the simpler forms—such as straight lines, triangles, squares—may be cut out of tinfoil pasted on glass, and apertures of any form may be produced with great accuracy by taking on glass a collodion photograph of a sheet of paper on which the required shapes are drawn in black.

Looking through any of these apertures at a luminous point, we see it surrounded with coloured spectra of very various forms, and of great beauty. The beautiful colours seen on looking through a bird's feather at a distant source of light, and the colours of striated surfaces, such as mother-of-pearl, are due to a similar cause. A beautiful phenomenon of the same kind is the aureole observed on looking at a candle flame through lycopodium powder strewn on glass. Two crossed gratings give a splendid picture in which a bright point is surrounded in all directions by spectra.

662. **Diffraction spectra.**—The most important of these figures are the *gratings proper*, which may be produced by arranging a series of fine wires parallel to each other, or by careful ruling on a piece of smoked glass, or by photographic reduction. Nobert has made such gratings by ruling lines on glass with a diamond, in which there are 12,000 lines in an inch in breadth. The late Dr. Stone constructed such gratings for reflection, by ruling lines on plates of nickel; this metal has the advantage of hardness, non-liability to tarnish, and great reflecting power.

If a grating is used instead of a single slit, as above described, the phenomena are in general the same, though of greater brilliancy. With homogeneous light and such a grating, there is seen, on each side of the central bright line, a series of sharply defined narrow bands and lines of light, gradually increasing in breadth and diminishing in intensity as their distance from the central line increases. If white light is used the white band is seen in the centre, and on each side of it a sharply defined isolated spectrum with the violet edges inwards. Next to this, and separated by a dark interval, is on each side a somewhat broader but similar spectrum, and then follow others which become fainter and broader and overlap each other. The brightness and sharpness of these spectra depend on the closeness of the lines, and on the opacity of the intermediate space. In those which are ruled by diamond on glass, the parts scratched represent the opaque parts.

For objective representation the image of a slit in a dark shutter, through which the sunlight enters, is focused by means of a convex lens on a screen at a distance, and then a grating is placed in the path of the rays.

The spectra produced by means of a grating are known as *diffraction spectra*. Very accurate gratings can now be easily and cheaply prepared by means of photography, and their use for scientific purposes is extending.

There are many points of difference between these spectra and those produced by the prism, and for scientific work the former are preferable.

A diffraction spectrum is the purer the greater the number of lines in the grating, provided they are equidistant. To obtain the maximum brightness, the opaque intervals should be as opaque and the transparent ones as transparent as possible. The spectra are, however, not more than $\frac{1}{10}$ as bright as prismatic spectra. By the use of sensitive photographic dry plates (622), even faint lights can be made visible and this objection removed.

On the other hand, in diffraction spectra, the colours are uniformly distributed in their true order and extent according to the difference in their wave-lengths, and according therefore to a property which is inherent in the light itself; while in prismatic spectra the red rays are concentrated, and the violet ones dispersed. In diffraction spectra the centre is the brightest part.

Fig. 647 represents a grating spectrum, together with an equally long spectrum produced by a flint-glass prism; the upper one being that produced by the grating. It will be seen that D in the one spectrum is in almost exactly the same position as F in the other.

Diffraction spectra have, moreover, the advantage of giving a far larger number of dark lines, and of giving them in their exact relative positions. Thus, in a particular region in which Angström had mapped 118 lines,

Draper, by means of a diffraction spectrum, was able to photograph at least 293. Diffraction spectra also extend farther in the direction of the ultra-violet, and give more dark lines in that region.

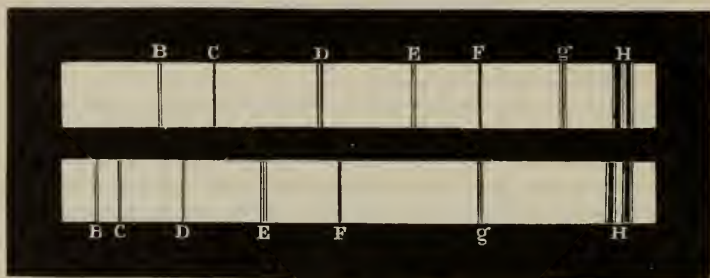

Fig. 647

The most perfect gratings were constructed by the late Professor Rowland, of Baltimore, by means of a machine specially planned and constructed for the purpose, the chief feature in which is a practically perfect screw. Using this machine, he has been able to rule gratings with as many as 43,000 lines to the inch, nor does this represent the limit of the power of the machine. Gratings with 14,000 or 28,000 lines give, however, the best definition. Another great improvement is to rule the gratings on curved instead of on flat surfaces; in this way the spectrum can be formed without a telescope, which is a matter of great importance, as telescopes interfere with a great many experiments. The spectroscope is thus reduced to its simplest form, so that an instrument of very high power may be constructed at a small cost.

By means of his gratings Professor Rowland was able to resolve lines in the spectrum which had never hitherto been separated.

It has been proposed to use the fine quartz threads prepared by Mr. Boys (89) for making gratings.

663. **Determination of wave-length.**—The relative positions of these bright and dark lines furnish a means of calculating the wave-length or length of undulation of any particular colour. We must first of all know the distance rs (fig. 646) of the first dark band from the bright one. The bands are not uniform in brightness or darkness, but there is in each case a position of maximum intensity, and it is from these that the distances are measured. If the bands are viewed through a telescope, the angle is observed through which the axis must be turned from the position in which the cross wire coincides with the centre of the bright band to that in which it coincides with the centre of the dark band. From this angle, which can be very accurately measured, the distance is easily calculated. When the diffraction bands are received on a screen, the distance may be directly measured, and most accurately by taking half the distance between the centres of the first pair of dark bands.

We have thus the similar triangles abc and rds , in which $ac : bc = rs : rd$

(fig. 646). Now bc may be taken equal to ab , the width of the slit, which can be measured directly with great accuracy by means of a micrometer screw (11), and rd is the distance of the screen. Hence

$$ac = \frac{rs \times ab}{rd}.$$

Now ac , the difference between as and sc , is equal to the length of an undulation of this particular colour. In one experiment with red light the width of the slit ab was $\cdot 375$ mm., the distance rs $\cdot 375$ mm., and the distance of the screen $2\cdot 325$ metres, which gave $ac = \frac{3\cdot 75 \times \cdot 375}{2325} = \cdot 000605$ mm. as the wavelength of red light. Using blue light the distance of rs was found to be $2\cdot 5$ mm. which gives $0\cdot 000404$.

Knowing the length of the undulations, we can easily calculate their number in a second, n , from the formula $n = \frac{v}{l}$ (226), where v is the velocity of light. Taking this at 3×10^{10} cm./sec. (518), we get for the red corresponding to the dark line B 436 billions as the number of oscillations in a second, and for the H in the violet 757 billions.

If, instead of a single slit, gratings are used, we have the possibility of more accurate results, for the contrast is greater, and thus the distance is more easily determined. The width of the slit is easily calculated by counting the number of lines in a given space.

664. **Colours of thin plates.** Newton's rings.—All transparent bodies, solids, liquids, or gases, when in sufficiently fine laminæ, appear coloured with very bright tints, especially by reflection. Crystals which cleave easily, and can be obtained in very thin plates, such as mica and selenite, show this phenomenon, which is also well seen in soap-bubbles and in the layers of air in cracks in glass and in crystals. Steel, in being tempered, becomes covered with a very thin layer of oxide, and exhibits the colour of thin plates, which change during heating as the oxide changes its thickness. A drop of oil spread rapidly over a large sheet of water exhibits all the colours of the spectrum in a constant order. A soap-bubble appears white at first, but, in proportion as it is blown out, brilliant iridescent colours appear, extending from the top, where it is thinnest. These colours are arranged in horizontal zones around the summit, which appears black when there is not thickness enough to reflect light, and the bubble then suddenly bursts.

Newton, who first studied the phenomena of the coloured rings in soap-bubbles, wishing to investigate the relation between the thickness of the thin plate, the colour of the rings, and their extent, produced them by means of a layer of air interposed between two glasses, one plane and the other slightly convex (fig. 648).

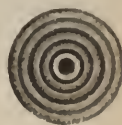
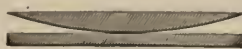

Fig. 648

The two surfaces being cleaned and exposed to ordinary light in front of a window, so as to reflect light, there is seen at the point of contact a black spot surrounded by six or seven coloured rings, the tints of which become

gradually less strong. If the glasses are viewed by transmitted light, the centre of the rings is white, and each of the colours is exactly complementary of that of the rings by reflection. The lens and the glass plate are usually arranged in a brass mount, which by means of three screws allows the pressure to be regulated.

With homogeneous light, red for example, the rings are successively black and red; the diameters of corresponding rings are less as the colour is more refrangible; but with white light the rings are of the different colours of the spectrum, which arises from the fact that, as the rings of the different simple colours have different diameters, they are not exactly superposed, but are more or less separated.

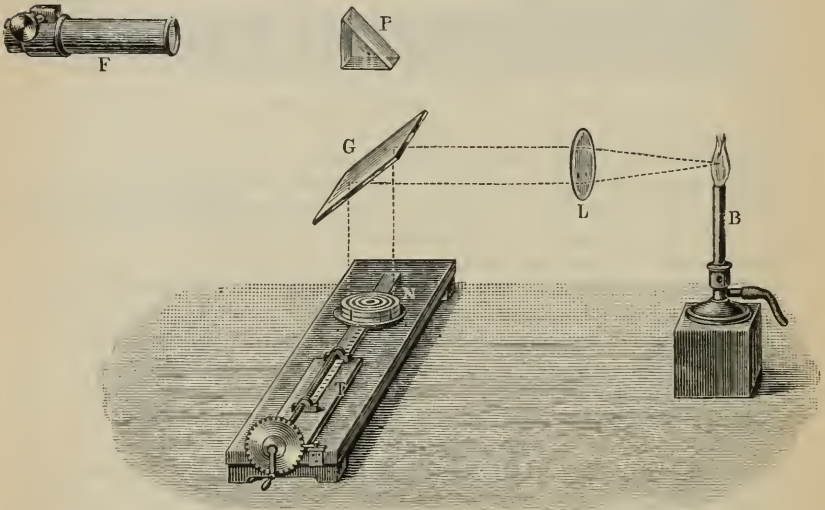

Fig. 649

For experiments on Newton's rings the apparatus represented in fig. 649 is suited. The glasses, N, for producing the rings are placed on the sliding part of a dividing machine. A pencil of monochromatic light from B, made parallel by the lens L, is thrown vertically downwards by the plate G. Above this is a totally reflecting prism, P, which sends the rays from N towards the telescope F.

The telescope is sighted so that the cross wire goes through the centre of the first ring; then by turning the screw the ten innermost bright and dark rings are successively brought in position; the respective diameters are then very easily determined by reading off on the scale the corresponding divisions.

It is usual to speak of the successive rings as the first, second, third, &c. By the *first* ring is understood that of least diameter. The thickness of the layer of air which corresponds to any particular ring is obtained as follows :—

Let GH (fig. 650) be the plane glass surface on which is laid the convex glass lens AEB, the radius, R, of which is ME. Let DF be the radius, ρ , of any given ring; FC = DE, or e is the thickness of the layer of air corresponding to this ring. Now from a well-known geometrical principle, $\rho^2 = e \times (2R - e)$; but since e is infinitesimally small in comparison with $2R$, the formula may be written $\rho^2 = e \times 2R$, so that knowing ρ and R it is easy to calculate e .

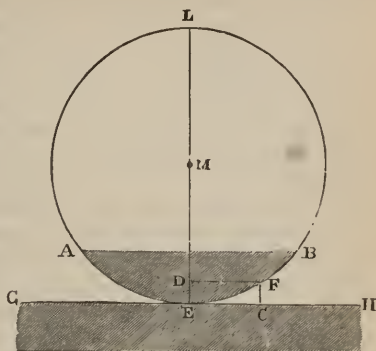

Fig. 650

Newton found that the thicknesses corresponding to the successive *dark* rings are proportional to the numbers 0, 2, 4, 6, while for the *bright* rings the thicknesses were proportional to 1, 3, 5 He found that for the first bright ring the thickness was

$\frac{1}{175000}$ of an inch, when the light used was the brightest part of the spectrum, that is, the part on the confines of the orange and yellow rays.

If the focal length of the lens is from three to four yards, the rings can be seen with the naked eye; but if the length is less, the rings must be looked at with a lens.

If the space between the lens and the plate contains, instead of air, a liquid of greater refrangibility, the rings contract owing to the shorter wavelength.

665. **Explanation of Newton's rings.**—Newton's rings, and all phenomena of thin plates, are simple cases of interference.

In fig. 651, let MNOP represent a thin plate of a transparent body, on which a pencil of parallel rays of homogeneous light, ab , impinges; this will be partially reflected in the direction bc , and partially refracted towards d . But the refracted ray will undergo a second reflection at the surface, OP; the reflected ray will emerge at e in the same direction as the pencil of light reflected at the first surface; and consequently the two pencils bc and ef will augment or diminish each other's effect according as they are in the same or opposite phases. We shall thus have an effect produced similar to that of the fringes described in article 659.

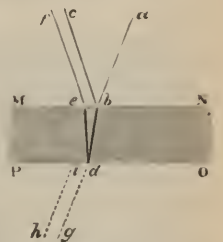

Fig. 651

POLARISATION OF LIGHT

666. **Polarisation by double refraction.**—It has been already seen that when a ray of light passes through a crystal of Iceland spar (655), it becomes divided into two rays of *equal intensity*; viz. the ordinary ray, and the extraordinary ray. These rays are found to possess other peculiarities which are expressed by saying they are *polarised*; namely, the ordinary ray in a principal plane, and the extraordinary ray in a plane at right angles to a principal plane. The phenomena which are thus designated may be

described as follows :—Suppose a ray of light which has undergone *ordinary* refraction in a crystal of Iceland spar to be allowed to pass through a second crystal, it will generally be divided into two rays ; namely, one ordinary, and the other extraordinary, but of *unequal intensities*. If the second crystal is turned round until the principal planes of the two crystals coincide—that is, until the crystals are in similar or in opposite positions—then the extraordinary ray disappears, and the ordinary ray is at its greatest intensity ; if the second crystal is turned farther round, the extraordinary ray reappears, and increases in intensity as the angle increases, while the ordinary ray diminishes in intensity until the principal planes are at right angles to each other, when the extraordinary ray is at its greatest intensity and the ordinary ray vanishes. These are the phenomena produced when the ray which experienced ordinary refraction in the first crystal passes through the second. If the ray which has experienced extraordinary refraction in the first crystal is allowed to pass through the second crystal, the phenomena are similar to those above described ; but when the principal planes coincide, an extraordinary ray alone emerges from the second crystal, and when the planes are at right angles, an ordinary ray alone emerges.

These phenomena may also be thus described :—Let O and E denote the ordinary and extraordinary rays produced by the first crystal. When O enters the second crystal, it generally gives rise to two rays, an ordinary (Oo) and an extraordinary (Oe), of unequal intensities. When E enters the second crystal, it likewise gives rise to two rays, viz. an ordinary (Eo) and an extraordinary (Ee), of unequal intensities, the intensities varying with the angle between the principal planes of the crystals. When the principal planes coincide, only two rays, viz. Oo and Ee, emerge from the second crystal, and when the planes are at right angles, only two rays, viz. Oe and Eo, emerge from the second crystal. Since O gives rise to an ordinary ray when the principal planes are parallel, and E gives rise to an ordinary ray when they are at right angles, it is manifest that O is related to the principal plane in the same manner that E is related to a plane at right angles to a principal plane.

This phenomenon, which is produced by all double-refracting crystals, was first observed by Huyghens in Iceland spar, and in consequence of a suggestion of Newton's was afterwards called *polarisation*. It remained, however, an isolated fact until the discovery of polarisation by reflection recalled the attention of physicists to the subject. The latter discovery was made by Malus in 1808.

667. **Polarisation by reflection.**—When a ray of light, *ab* (fig. 652), falls on a polished unsilvered glass surface, *fghi*, inclined to it at an angle of $35^{\circ} 25'$, so that the angle of incidence is $54^{\circ} 35'$, it is reflected, and the reflected ray is polarised in the plane of reflection. If it were transmitted through a crystal of Iceland spar, it would pass through without bifurcation, and undergo an ordinary refraction, when the principal plane coincides with the plane of reflection ; it would also be transmitted without bifurcation, but undergo extraordinary refraction, when the principal plane is at right angles to the plane of reflection ; in other positions of the crystal it would give rise to an ordinary and an extraordinary ray of different intensities, according to the angle between the plane of reflection and the principal

plane of the crystal. The peculiar property which the light has acquired by reflection at the surface $fghi$ can also be exhibited as follows:—Let the polarised ray bc be received at c , on a second surface of unsilvered glass, at the same angle, viz. $35^\circ 25'$. If the surfaces are parallel, the ray is reflected; but if the second plate is caused to turn round the line cb , the intensity of the reflected ray continually diminishes, and when the glass surfaces are at right angles to each other, no light is reflected. By continuing to turn the upper mirror the intensity of the reflected ray gradually increases, and attains a maximum value when the surfaces are again parallel.

The above statement will serve to describe the phenomenon of polarisation by reflection so far as the principles are concerned; the apparatus best adapted for exhibiting the phenomenon will be described farther on.

668. **Angle of polarisation.**—The *polarising angle* of a substance is the angle which the incident ray must make with the perpendicular to a plane polished surface of that substance in order that the polarisation may be complete. For glass this angle is $54^\circ 35'$, and if in the preceding experiment the lower mirror were inclined in any other angle than this, the light would not be completely polarised in any position; this would be shown by its being partially reflected from the upper surface in all positions. Such light is said to be *partially polarised*. The polarising angle for water is $52^\circ 45'$; for quartz, $57^\circ 32'$; for diamond, 68° ; and it is $56^\circ 30'$ for obsidian, a kind of volcanic glass which is often used in these experiments.

Light which is reflected from the surface of water, from a slate roof, from a polished table, or from oil paintings, is all more or less polarised. The ordinary light of the atmosphere is frequently polarised, especially in the earlier and later periods of the day, when the solar rays fall obliquely on the atmosphere. Almost all reflecting surfaces may be used as polarising mirrors. Metal surfaces form, however, an important exception.

Brewster discovered the following remarkably simple law in reference to the polarising angle:—

The polarising angle of a substance is that angle of incidence for which the reflected polarised ray is at right angles to the refracted ray.

Thus, in fig. 653, if si is the incident, ir the refracted, and if the reflected ray, the polarisation is most complete when fi is at right angles to ir .

The *plane of polarisation* is the plane of reflection in which the light becomes polarised; it coincides with the plane of incidence, and therefore contains the polarising angle.

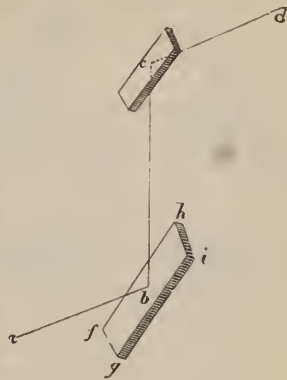

Fig. 652



Fig. 653

A simple geometrical consideration will show that the above law may be thus expressed :—*The tangent of the angle of polarisation of a substance is equal to its refractive index.* As the refractive index differs with the different colours, it follows that the angle of polarisation cannot be the same for all colours. This explains why a ray of white light is never completely polarised.

669. **Polarisation by single refraction.**—When an unpolarised pencil of light falls upon a glass plate placed at the polarising angle, one part is reflected; the other part becomes refracted in passing through the glass, and the transmitted light is now found to be partially polarised. If the light which has passed through one plate, and whose polarisation is very feeble, is transmitted through a second plate parallel to the first, the effects become more marked, and by ten or twelve plates are tolerably complete. A bundle of such plates, for which the best material is the glass used for covering microscopic objects, fitted in a tube at the polarising angle, is frequently used for examining or producing polarised light.

If a ray of light falls at any angle on a transparent medium, the same holds good with a slight modification. In fact, part of the light is reflected and part refracted, and both are found to be partially polarised, *equal quantities in each being polarised, and their planes of polarisation being at right angles to each other.* It is, of course, to be understood that the polarised portion of the reflected light is polarised in the plane of reflection, which is likewise the plane of refraction.

670. **Polarising instruments.**—Every instrument for investigating the properties of polarised light consists essentially of two parts—one for polarising the light, the other for ascertaining or exhibiting the fact of the light having undergone polarisation. The former part is called the polariser, the latter the analyser. Thus in art. 666 the crystal producing the first refraction is the *polariser*, that producing the second refraction is the *analyser*. In art. 667 the mirror at which the first reflection takes place is the polariser, that at which the second reflection takes place is the analyser. Some of the most convenient means of producing polarised light will now be described, and it may be remarked that any instrument that can be used as a polariser can also be used as an analyser. The experimenter has, therefore, considerable liberty of selection.

671. **Norremberg's apparatus.**—The simplest instrument for polarising light is that invented by Norremberg. It may be used for repeating most of the experiments on polarised light.

It consists of two brass rods, *b* and *d* (fig. 654), which support an unsilvered mirror, *n*, of ordinary glass, movable about a horizontal axis. A small graduated circle indicates the angle of inclination of the mirror. Between the feet of the two columns there is a silvered glass, *p*, which is fixed and horizontal. At the upper end of the columns is a graduated plate, *i*, in which a circular disc, *o*, rotates. This disc, in which there is a square aperture, supports a mirror of black glass, *m*, which is inclined to the vertical at the polarising angle. An annular disc, *k*, can be fixed at different heights on the columns by means of a screw. A second ring, *a*, may be moved around the axis. It supports a black screen, in the centre of which there is a circular aperture.

When the mirror n makes with the vertical an angle of $35^{\circ} 25'$, which is the complement of the polarising angle for glass, the rays of light, Sn , which meet the mirror at this angle become polarised, and are reflected in the direction np towards the mirror p , which sends them in the direction pnr . After having passed through the glass, n , the polarised ray falls upon the blackened glass m under an angle of $35^{\circ} 25'$, because the mirror makes exactly the same angle with the vertical. But if the disc, o , to which the mirror, m , is fixed, be turned horizontally, the intensity of the light reflected from the upper mirror gradually diminishes, and totally disappears when it has been moved through 90° . The position is that represented in the diagram: the plane of incidence on the upper mirror is then perpendicular to the plane of incidence, Snp , on the mirror, n . When the upper mirror is again turned, the intensity of the light increases until it has passed through 180° , when it again reaches a maximum. The mirrors, m and n , are then parallel. The same phenomena are repeated as the mirror, m ,

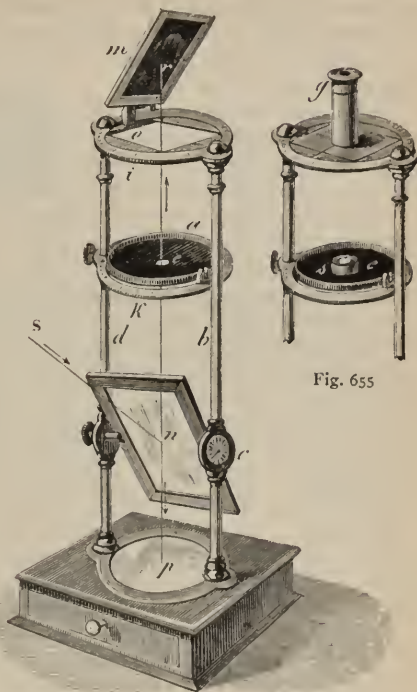

Fig. 655

Fig. 654

672. **Tourmaline.**—The primary form of this crystal is a regular hexagonal prism. Tourmaline, as already stated, is a negative uniaxial crystal, and its optic axis coincides with the axis of the prism. For optical purposes a plate is cut from it parallel to the axis. When a ray of light passes through such a plate, an ordinary ray and an extraordinary ray are produced polarised in planes at right angles to each other; viz. the former in a plane at right angles to the plate parallel to the axis, and the latter in a plane at right angles to the axis. The crystal possesses, however, the remarkable property of rapidly absorbing the ordinary ray; consequently, when a plate of a certain thickness is used, the extraordinary ray alone emerges—in other words, a beam of common light emerges from the plate of tourmaline polarised in a plane at right angles to the axis of the crystal. If the light

thus transmitted be viewed through another similar plate held in a parallel position, little change will be observed, excepting that the intensity of the transmitted light will be about equal to that which passes through a plate of double the thickness; but if the second tourmaline be slowly turned, the light will become feebler, and will ultimately disappear when the axes of the two plates are at right angles.

The objections to the use of the tourmaline are that it is not very transparent, and that plates of considerable thickness must be used if the polarisation is to be complete. For unless the ordinary ray is completely absorbed the emergent light will be only partially polarised.

Herapath discovered that iodoquinine sulphate has the property of polarising light in a remarkable degree. Unfortunately it is a very fragile substance, and difficult to obtain in large crystals.

673. **Double-refracting prism of Iceland spar. Double-image prism.**—When a ray of light passes through an ordinary rhombohedron of Iceland spar, the ordinary and extraordinary rays emerge parallel to the original ray, consequently the separation of the rays is proportional to the thickness of the prism. But if the crystal is cut so that its faces are inclined to each other, the deviations of the ordinary and extraordinary rays will be different, they will not emerge parallel, and their separation will be greater as their distance from the prism increases. The light, however, becomes decomposed in passing through the prism, and the rays will be coloured. It is therefore necessary to *achromatise* (595) the prism, which is done by combining it with a prism of glass with its refracting angle turned in the contrary direction (fig. 656). In order to obtain the greatest amount of divergence, the prism should be cut with its refracting edge parallel to the optic axis, and this is always done.

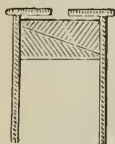

Fig. 656

Let us suppose that a ray of polarised light passes along the axis of the cylinder (fig. 656), and let us suppose that the cylinder is caused to turn slowly about its axis; then the resulting phenomena are exactly like those already described (656). Generally there will be an ordinary and an extraordinary ray produced, whose relative intensities will vary as the tube is turned. But in two opposite positions the ordinary ray alone will emerge, and in two others at right angles to the former the extraordinary ray will alone emerge. When the ordinary ray alone emerges, the principal plane of the crystal—that is, a plane at right angles to its face, and parallel to its refracting edge—coincides with the original plane of polarisation of the ray. Consequently, by means of the prism, it can be ascertained both that the ray is polarised, and likewise in which plane it is polarised. A compound prism constructed in the manner described is called a *double-image prism*.

674. **Nicol's prism.**—The Nicol's prism is one of the most valuable means of polarising light, for it is perfectly colourless, it polarises light completely, and it transmits only one beam of polarised light, the other being entirely suppressed.

It is constructed from a rhombohedron of Iceland spar, about an inch in height and $\frac{1}{3}$ of an inch in breadth. This is bisected in the plane which passes through the obtuse angles as shown in fig. 657, that is, along the

plane ab (fig. 658). The two halves are then again joined in the same order by means of Canada balsam.

The principle of the Nicol's prisin is this:—The refractive index of Canada balsam, 1.549, is less than the ordinary index of Iceland spar, 1.654,



Fig. 657

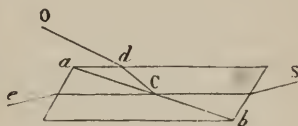

Fig. 658

but greater than its extraordinary index, 1.483. Hence when a luminous ray SC (fig. 658) enters the prism, the ordinary ray is totally reflected on the surface, ab , and takes the direction CdO , by which it is refracted out of the crystal, while the extraordinary ray, Ce , emerges alone. Since the Nicol's prism allows only the extraordinary ray to pass, it may be used like a tourmaline, as an analyser or as a polariser.

Foucault replaced the layer of Canada balsam by one of air, the two prisms being kept together by the mounting. The advantage of this is that the section ab (fig. 658) need not be so acute, so that the prism becomes shorter, and therefore cheaper.

Nicol's prism is the most important feature of most polarising apparatus. It is better than the polarising mirror on account of its more complete polarisation, and has the advantage over tourmaline of giving a colourless field of view.

675. **Physical theory of polarised light.**—The explanation of the dark bands produced by the interference of light in art. 659 resembles that of the formation of nodes and loops given in art. 278.

It might hence be supposed that the vibrations producing light are quite similar to those producing sound. But this is by no means the case. In fact, no assumption is made in art. 659 as to the *direction* in which the vibrating particles move, and accordingly the explanation is equally true whether the particles vibrate in the direction AB , BA , along which the disturbance is travelling, or at right angles to AB . As a matter of fact, the former is the case with the vibrations producing sound, the latter with the vibrations producing light. In other words, the vibrations producing sound take place in the direction of propagation, the vibrations producing light are *transverse* to the direction of propagation.

This assumption as to the direction of the vibration of the particles of ether producing light is rendered necessary, and is justified, by the phenomena of polarisation.

When a ray of light is polarised, all the particles of ether in that ray vibrate in straight lines parallel to a certain direction in the front of the wave corresponding to the ray.

When a ray of light enters a double-refracting medium, such as Iceland spar, it becomes divided into two, as we have already seen. Now it can be shown to be in strict accordance with mechanical principles that, if a medium

possesses unequal elasticity in different directions, a plane wave produced by transversal vibrations entering that medium will give rise to two plane waves moving with different velocities within the medium, and the vibrations of the particles in front of these waves will be in directions parallel respectively to two lines at right angles to each other. If, as is assumed in the undulatory theory of light, the ether exists in a double-refracting crystal in such a state of unequal elasticity, then the two plane waves will be formed as above described, and these, having different velocities, will give rise to two rays of unequal refrangibility (652). This is the physical account of the phenomenon of double refraction. It will be remarked that the vibrations corresponding to the two rays are transversal, rectilinear, and in directions perpendicular to each other in the rays respectively. Accordingly the same theory accounts for the fact that the two rays are both polarised, and in planes at right angles to each other.

It is a point still unsettled whether, when a ray of light is polarised with respect to a given plane, the vibrations take place in directions within or perpendicular to that plane. Fresnel was of the latter opinion, and the evidence is on the whole in favour of his view. It is, however, convenient in some cases to regard the plane of polarisation as that plane in which the vibrations take place.

COLOURS PRODUCED BY THE INTERFERENCE OF POLARISED LIGHT

676. **Laws of the interference of polarised rays.**—After the discovery of polarisation, Fresnel and Arago tried whether polarised rays presented the same phenomena of interference as ordinary rays. They were thus led to the discovery of the following laws in reference to the interference of polarised light, and, at the same time, of the brilliant phenomena of coloration, which will be presently described.

I. When two rays polarised in the same plane interfere with each other, they produce, by their interference, fringes of the very same kind as if they were common light.

II. When two rays of light are polarised at right angles to each other, they produce no coloured fringes in the same circumstances in which two rays of common light would produce them. When the rays are polarised in planes inclined to each other at any other angles, they produce fringes of intermediate brightness; and if the angle is made to change, the fringes gradually decrease in brightness from 0° to 90° , and are totally obliterated at the latter angle.

III. Two rays originally polarised in planes at right angles to each other may be subsequently brought into the same plane of polarisation without acquiring the power of forming fringes by their interference.

IV. Two rays polarised at right angles to each other, and afterwards brought into the same plane of polarisation, produce fringes by their interference like rays of common light, provided they originated in a pencil the whole of which was originally polarised in any one plane.

V. In the phenomena of interference produced by rays that have suffered double refraction, a difference of half an undulation must be allowed, as one of the pencils is retarded by that quantity, from some unknown cause.

677. **Effect produced by causing a pencil of polarised rays to traverse a double-refracting crystal.**—The following important experiment may be made most conveniently by Norremberg's apparatus (fig. 654). At *g* (fig. 655) there is a Nicol's prism. A plate of a double-refracting crystal cut parallel to its axis is placed on the disc at *e*. In the first place, however, suppose the plate of the crystal to be removed. Then, since the Nicol's prism allows only the extraordinary ray to pass when it is turned so that its principal plane coincides with the plane of reflection, no light will be transmitted (674). Place the plate of doubly refracting crystal, which is supposed to be of moderate thickness, in the path of the reflected ray at *e*. Light is now transmitted through the Nicol's prism. On turning the plate, the intensity of the transmitted light varies; it reaches its maximum when the principal plane of the plate is inclined at an angle of 45° to the plane of reflection, and disappears when these planes either coincide with or are at right angles to each other. The light in this case is white. The same or equivalent phenomena are produced when any other analyser is used. Thus, assume the double-image prism to be used, and suppose the crystal to be removed. Then, generally, two rays are transmitted; but if the principal plane of the analyser is turned in the plane of primitive polarisation, the ordinary ray only is transmitted, and then when turned through 90° the extraordinary ray only is transmitted. Let the analyser be turned into the former position, then, when the plate is interposed, both ordinary and extraordinary rays are seen, and when the plate is slowly rotated, the ordinary and extraordinary rays are seen to vary in intensity, the latter vanishing when the principal plane of the polarising plate either coincides with, or is at right angles to, the plane of primitive polarisation.

678. **Effect produced when the plate of crystal is very thin.**—In order to exhibit this, take a thin film of *selenite* or *mica* between the twentieth and sixtieth of an inch thick, and interpose it as in the last article. If the thickness of the film is uniform, the light now transmitted through the analyser will be no longer white, but of a uniform tint; the colour of the tint being different for different thicknesses—for instance, red, or green, or blue, or yellow, according to the thickness; the intensity of the colour depending on the inclination of the principal plane of the film to the plane of reflection, being greatest when the angle of inclination is 45° . Let us now suppose the crystalline film to be fixed in that position in which the light is brightest, and suppose its colour to be *red*. Let the analyser (the Nicol's prism) be turned round, the colour will grow fainter, and when it has been turned through 45° , the colour disappears, and no light is transmitted; on turning it further, the complementary colour, *green*, makes its appearance, and increases in intensity until the analyser has been turned through 90° ; after which the intensity diminishes until an angle of 135° is attained, when the light again vanishes, and, on increasing the angle, it changes again into red. Whatever be the colour proper to the plate, the same series of phenomena will be observed, the colour passing into its complementary when the analyser is turned. That the colours are really complementary is proved by using a double-refracting prism as analyser. In this case two rays are transmitted, each of which goes through the same changes of colour and intensity as the single ray described above; but whatever be the colour and

intensity of the one ray in a given position, the other ray will have the same when the analyser has been turned through an angle of 90° . Consequently, these two rays give simultaneously the appearances which are successively presented in the above case by the same ray at an interval of 90° . If now the two rays are allowed to overlap, they produce white light; thereby proving their colours to be complementary.

Instead of using plates of different thicknesses to produce different tints, the same plate may be employed inclined at different angles to the polarised ray. This causes the ray to traverse the film obliquely, and, in fact, amounts to an alteration in its thickness.

With the same substance, but with plates of increasing thickness, the tints follow the laws of the colours of Newton's rings (665). The thickness of the plate must, however, be different from that of the layer of air in the case of Newton's rings to produce corresponding colours. Thus corresponding colours are produced by a plate of mica and a layer of air when the thickness of the former is about 400 times that of the latter. In the case of selenite the thickness is about 230 times, and in the case of Iceland spar about 13 times, that of the corresponding layer of air.

679. **Explanation of the phenomena described above.**—The phenomena described in the last articles admit of complete explanation by the undulatory theory, but not without the aid of abstruse mathematical calculations. What follows will show the nature of the explanation. Let us suppose, for convenience, that in the case of a polarised ray the particles of ether vibrate in the plane of polarisation (675), and that the analyser is a double-image prism, with its principal plane in the plane of primitive polarisation; then the vibrations, being wholly in that plane, have no resolved part in a plane at right angles to it, and, consequently, no extraordinary ray passes through the analyser; in other words, only an ordinary ray passes. Now take the crystalline plate cut parallel to the axis, and let it be interposed in such a manner that its principal plane makes any angle (θ) with the plane of primitive polarisation. The effect of this will be to cause the vibrations of the primitive ray to be resolved in the principal plane and at right angles to the principal plane of the crystal, thereby giving rise to an ordinary ray (O) and an extraordinary ray (E), which, however, do not become separated on account of the thinness of the plate. They will not form a single plane polarised ray on leaving the plate, since they are unequally retarded in passing through it, and consequently leave it in different phases. Since neither of the planes of polarisation of O and E coincides with the principal plane of the analyser, the vibrations composing them will again be resolved, viz. O gives rise to O_o and O_e , and E gives rise to E_o and E_e . But the vibrations composing O_o and E_o , being in the same phase, give rise to a single ordinary ray I_o , and in like manner O_e and E_e give rise to a single extraordinary ray, I_e . Thus the interposition of the plate of crystal restores the extraordinary ray.

Suppose the angle θ to be either 0° or 90° . In either case the vibrations are transmitted through the plate without resolution; consequently they remain wholly in the plane of primitive polarisation, and on entering the analyser cannot give rise to an extraordinary ray.

If the Nicol's prism is used as an analyser the ordinary ray is suppressed

by mechanical means. Consequently only Ie will pass through the prism, and that for all values of θ except 0° and 90° .

A little consideration will show that the joint intensities of all the rays existing at any stage of the above transformations must continue constant, but that the intensities of the individual rays will depend on the magnitude of θ ; and when this circumstance is examined in detail, it explains the fact that Ie increases in intensity as θ increases from 0° to 45° , and then decreases in intensity as θ increases from 45° to 90° .

In regard to the colour of the rays it is to be observed that the formulæ for the intensities of Io and Ie contain a term depending on the length of the wave and the thickness of the plate. Consequently, when white light is used the relative intensities of its component colours are changed, and therefore Io and Ie will each have a prevailing tint, which will be different for different thicknesses of the plate. The tints will, however, be complementary, since the joint intensities of Io and Ie being the same as that of the original ray, they will, when superimposed, restore all the components of that ray in their original intensities, and therefore produce white light.

680. Coloured rings produced by polarised light in traversing double-refracting films.—In the experiments with Norremberg's apparatus which have just been described (679), a pencil of parallel rays traverses the film of crystal perpendicularly to its faces, and as all parts of the film act in the same manner, the tint is everywhere the same. But when the incident rays traverse the plate under different obliquities, which comes to the same thing as if they traversed plates differing in thickness, coloured rings are formed similar to Newton's rings.



Fig. 659

The best method of observing these new phenomena is by means of the *tourmaline pincette* or tongs (fig. 659). This is a small instrument consisting of two tourmalines cut parallel to the axis, each of them being fitted in a copper disc. These two discs, which are perforated in the centre, and blackened, are mounted in two rings of silvered copper, which is coiled, as shown in the figure, so as to form a spring, and press together the tourmalines. The tourmalines turn with the disc, and may be so arranged that their axes are either perpendicular or parallel.

The crystal to be experimented upon, being fixed in the centre of a cork disc, is placed between the two tourmalines, and the pincette is held before the eye so as to view diffused light. The tourmaline farthest from the eye acts as polariser and the other as analyser. If the crystal thus viewed is uniaxial, and cut perpendicularly to the axis, and a homogeneous light—red, for instance—is looked at, a series of alternately dark and red rings is seen. With another simple colour similar rings are obtained, but their diameter decreases as the refrangibility of the colour increases. On the other hand, the diameters of the rings diminish when the thickness of the plates increases, and beyond a certain thickness no more rings are produced. If, instead of illuminating the rings by homogeneous light, white light is

used, then, since the rings of the different colours produced have not the same diameter, they are partially superposed, and produce very brilliant variegated colours.

The position of the crystal has no influence on the rings, but this is not the case with the relative position of the two tourmalines. For instance, in experimenting on Iceland spar cut perpendicular to the axis, and from 1 to 20 millimetres in thickness, when the axes of the tourmalines are perpendicular, a beautiful series of rings is seen, brilliantly coloured, and traversed by a black cross, as shown in fig. 1, Plate II. If the axes of the tourmalines are parallel, the rings have tints complementary to those they had at first, and there is a white cross (fig. 2, Plate II.) instead of a black one.

In order to understand the formation of these rings when polarised light traverses double-refracting films, it must first be premised that these films are traversed by a converging conical pencil, whose summit is the eye of the observer. Hence it follows that the virtual thickness of the film which the rays traverse increases with their divergence; but for rays of the same obliquity this thickness is the same; hence there result different degrees of retardation of the ordinary with respect to the extraordinary ray at different points of the plate, and therefore different colours are produced at different distances from the axis, but the same colours will be produced at the same distance from the axis, and consequently the colours are arranged in circles round the axis. The arms of the black cross are parallel to the optic axis of each of the tourmalines, and are due to an absorption of the polarised light in these directions. When the tourmalines are parallel the vibrations are transmitted, and hence the white cross.

Analogous effects are produced with all uniaxial crystals; for instance, tourmaline, emerald, sapphire, beryl, mica, pyromorphite, and potassium ferrocyanide.

681. **Rings in biaxial crystals.**—In biaxial crystals, coloured rings are also produced, but their form is more complicated. The coloured bands, instead of being circular and concentric, have the form of curves, with two centres, the centre of each system corresponding to an axis of the crystal. Figs. 4, 5, and 6, Plate II., represent the curves seen when a plate of either cerussite, topaz, or nitre, cut perpendicularly to the medial line (658), is placed between the two tourmalines, the plane containing the axis of the crystal being in the plane of primitive polarisation. When the axes of the two tourmalines are at right angles to each other, fig. 4, Plate II., is obtained. On turning the crystal without altering the tourmalines, fig. 5, Plate II., is seen, which changes it to fig. 6, Plate II., when the crystal has been turned through 45° . If the axes of the tourmalines are parallel, the same coloured curves are obtained, but the colours are complementary, and the black cross changes into white. The angle between the optic axes in the case of nitre is only $5^\circ 20'$, and hence the whole system can be seen at once. But when the angle exceeds 20° to 25° , the two systems of curves cannot be simultaneously seen. There is then only one dark brush instead of the cross, and the bands are not oval, but circular. Fig. 3, Plate II., represents the phenomenon as seen with arragonite.

Sir John Herschel, who measured the rings produced by biaxial crystals

I

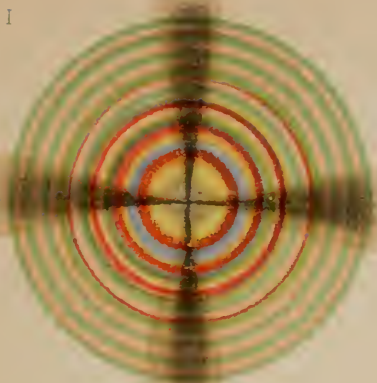

IV

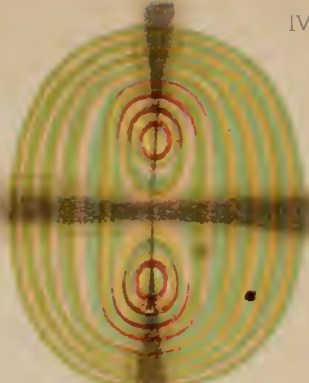

II



V



III



VI

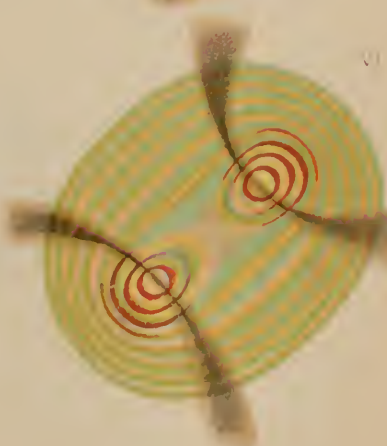

referred them to the kind of curve known in geometry as the *lemniscate*, in strict accordance with the principles of the undulatory theory of light.

The observation of the system of rings which plates of crystals give in polarised light presents a means of distinguishing between optical uniaxial and optical biaxial crystals, even in cases in which no conclusion can be drawn as to the system in which a mineral crystallises from mere morphological reasons. In this way the optical investigation becomes a valuable aid in mineralogy; as, for example, in the case of mica, of which there are two mineralogical species, the uniaxial and the biaxial.

All the phenomena which have been described are only obtained by means of polarised light. Hence, a double refracting film, with either a Nicol's prism or a tourmaline as analyser, may be used to distinguish between polarised and unpolarised light, that is, as a polariscope.

682. **Colours produced by compressed or by unannealed glass.**—Ordinary glass is isotropic, and is therefore not endowed with the power of double refraction. It acquires this property, however, if by any cause its elasticity becomes more modified in one direction than in another. Glass may become anisotropic by being strongly compressed in a given direction, or curved, or tempered, that is to say, cooled after having been heated. If the glass is then traversed by a beam of polarised light, effects of colour are obtained which are entirely analogous to those described in the case of doubly refracting crystals. They are, however, susceptible of far greater variety, according as the plates of glass have a circular, square, rectangular, or triangular shape, and according to the degree of tension of their particles.

Fig. 660



Fig. 661

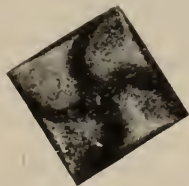

Fig. 662



Fig. 663



Fig. 664



Fig. 665



When the polariser is a mirror of black glass, on which the light of the sky is incident, and the analyser is a Nicol's prism, and a square plate of compressed glass is placed between polariser and analyser, the appearances represented in figs. 660, 661, 663 are successively presented; figs. 662

and 665 represent the appearances produced by a circular plate under the same circumstances ; and fig. 664 that produced when one rectangular plate is superposed on another. This figure also varies when the system of plates is turned.

In consequence of being rapidly cooled, glass often acquires a strained condition. Hence, when the masses of glass, more especially the larger ones from which lenses are made, are examined by polarised light, the existence of strains may be revealed which would render it useless to go to the trouble and expense of working such masses, as they would probably break in the operation.

ELLIPTIC, CIRCULAR, AND ROTATORY POLARISATION

683. **Definition of elliptic and circular polarisation.**—In the cases hitherto considered, the particles of ether composing a polarised ray vibrate in parallel straight lines ; to distinguish this case from those we are now to consider, such light is frequently called *plane polarised light*. It sometimes happens that the particles of ether describe *ellipses* about their positions of rest, the planes of the ellipses being perpendicular to the direction of the ray. If the axes of these ellipses are unequal and parallel, the ray is said to be *elliptically polarised*. In this case the particles which, when at rest, occupied a straight line, are, when in motion, arranged in a helix round the line of their original position as an axis, the helix changing from instant to instant. If the axes of the ellipses are equal, they become circles, and the light is said to be *circularly polarised*. If the minor axes become zero, the ellipses coincide with their major axes, and the light becomes *plane polarised*. Consequently, *plane* polarised light and *circularly* polarised light are particular cases of elliptically polarised light.

684. **Theory of the origin of elliptic and circular polarisation.**—Let us in the first place consider a simple pendulum (56) vibrating in any plane, the arc of vibration being small. Suppose that, when in its lowest position, it received a blow in a direction at right angles to the direction of its motion, such as would make it vibrate in an arc at right angles to its arc of primitive vibration, it follows from the law of the composition of velocities that the joint effect will be to make it vibrate in an arc inclined at a certain angle to the arc of primitive vibration, the magnitude of the angle depending on the magnitude of the blow (58). If the blow communicated a velocity equal to that with which the body is already moving, the angle would be 45° . Next suppose the blow to communicate an equal velocity, but to be struck when the body is at its highest point, this will cause the particle to describe a circle, and to move as a conical pendulum. If the blow is struck under any other circumstances, the particle will describe an ellipse. Now as the two blows would produce separately two simple vibrations in directions at right angles to each other, we may state the result arrived at as follows :—If two rectilinear vibrations are superinduced on the same particle in directions at right angles to each other, then : 1. If they are in the same or opposite phases, they make the point describe a rectilinear vibration in a direction inclined at a certain angle to either of the original vibrations. 2. But if their phases differ by 90° or a quarter of a vibration, the particle will describe a circle, provided the vibrations

are equal. 3. Under other circumstances the particle will describe an ellipse.

To apply this to the case of polarised light. Suppose two rays of light polarised in perpendicular planes to coincide, any particle in the common path of the rays will have simultaneously two motions in directions at right angles to each other. Consequently—1. If the vibrations are in the same or opposite phases, the light resulting from the two rays is plane polarised. 2. If the rays are of equal intensity, and their phases differ by 90° , the resulting light is circularly polarised. 3. Under other circumstances the light is elliptically polarised.

As an example, if reference is made to arts. 679 and 680, it will be seen that the rays denoted by O and E are superimposed in the manner above described. Consequently, the light which leaves the thin double refracting plate is elliptically polarised. If, however, the principal plane of the thin plate is turned so as to make an angle of 45° with the plane of primitive polarisation, O and E have equal intensities; and if, further, the plate is made of a certain thickness, so that the phases of O and E may differ by 90° , or by a quarter of a vibration, the light which emerges from the plate is circularly polarised. This method may be employed to produce circularly polarised light.

Circular or elliptic polarisation may be either *right-handed* or *left-handed*, or what is sometimes called *dextrogyrate* and *laevogyrate*. If the observer looks along the ray in the direction of propagation, from polariser to analyser, then, if the particles move in the same direction as the hands of a watch with its face to the observer, the polarisation is right-handed.

685. **Fresnel's rhomb.**—This is a means of obtaining circularly polarised light. We have just seen (684) that, to obtain a ray of circularly polarised light, it is sufficient to decompose a ray of plane polarised light in such a manner as to produce two rays of light of equal intensity polarised in planes at right angles to each other, and differing in their paths by a quarter of an undulation. Fresnel effected this by means of a rhomb which has received his name. It is made of glass; its acute angle is 54° , and its obtuse 126° . If a ray (*a*, fig. 666) of plane polarised light falls perpendicularly on the face of AB, it will undergo two total internal reflections at an angle of about 54° , one at E, and the other at F, and will emerge perpendicularly from the face CD.

If the plane ABCD is inclined at an angle of 45° to the plane of polarisation, the polarised ray will be divided into two coincident rays, with their planes of polarisation at right angles to each other, and it appears that one of them loses exactly a quarter of an undulation, so that on emerging from the rhomb the ray is circularly polarised. If the ray emerging as above from Fresnel's rhomb is examined, it will be found to differ from plane polarised light in this, that, when it passes through a double-image prism, the ordinary and extraordinary rays are of equal intensity in all positions of the prism. Moreover, it differs from ordinary light in this, that, if it pass through a

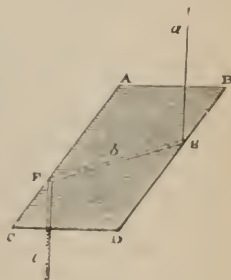

Fig. 666

second rhomb placed parallel to the first, a second quarter of an undulation will be lost, so that the parts of the original plane polarised ray will differ by half an undulation, and the emergent ray will be plane polarised; moreover the plane of polarisation will be inclined at an angle of 45° to ABCD, but on the *other side* from the plane of primitive polarisation.

686. **Elliptic polarisation.**—In addition to the method already mentioned (685), elliptically polarised light is generally obtained whenever plane polarised light suffers reflection. Polarised light reflected from metals becomes elliptically polarised, the degree of ellipticity depending on the direction of the incident ray, and of its plane of polarisation, as well as on the nature of the reflecting substance. When reflected from silver, the polarisation is almost circular, and from galena almost plane. If elliptically polarised light be analysed by the Nicol's prism, it never vanishes, though at alternate positions it becomes fainter; it is thus distinguished from plane and from circular polarised light. If analysed by Iceland spar, neither image disappears, but they undergo changes in intensity.

Light can also be polarised elliptically in Fresnel's rhomb. If the angle between the planes of primitive polarisation and of incidence be any other than 45° , the emergent ray is elliptically polarised.

687. **Rotatory polarisation.**—Rock crystal or quartz possesses a remarkable property which was long regarded as peculiar to itself among all crystals, though it has been since found to be shared by tartaric acid and its salts, together with some other crystallised bodies. This property is called *rotatory polarisation*, and may be described as follows: Let a ray of homogeneous light be polarised, and let the analyser, say a Nicol's prism, be turned till the light does not pass through it. Take a thin section of a quartz crystal cut at right angles to its axis, and place it between the polariser and the analyser with its plane at right angles to the rays. The light will now pass through the analyser. The phenomenon is not the same as that previously described (677); for, if the rock crystal is turned round its axis, no effect is produced, and if the analyser is turned, the ray is found to be *plane polarised* in a plane inclined at a certain angle to the plane of primitive polarisation. If the light is red, and the plate 1 millimetre thick, this angle is about 17° ; that is, if the analyser is turned through 17° the light is cut off. In some specimens of quartz the plane of polarisation is turned to the right hand, in others to the left hand. Specimens of the former kind are said to be right-handed, those of the latter kind left-handed (684). This difference corresponds to a difference in crystallographic structure. The property possessed by rock crystal of turning the plane of polarisation through a certain angle was investigated by Biot, who, amongst other results, arrived at this:—For a given colour, the angle through which the plane of polarisation is turned is proportional to the thickness of the quartz.

688. **Physical explanation of rotatory polarisation.**—The explanation of the phenomenon described in the last article is as follows:—When a ray of polarised light passes along the axis of the quartz crystal, it is divided into two rays of *circularly* polarised light of equal intensity, which pass through the crystal with different velocities. In one the circular polarisation is right-handed, in the other left-handed (684). The existence of these rays was proved by Fresnel, who succeeded in separating them. On emerging from

the crystal they are compounded into a plane polarised ray ; but, since they move with unequal velocities within the crystal, they emerge in different phases, and consequently the plane of polarisation will not coincide with the plane of primitive polarisation. This can be readily shown by reasoning similar to that employed in art. 684. The same reasoning will also show that the plane of polarisation will be turned to the right or left, according as the right-handed or left-handed ray moves with the greater velocity. Moreover, the amount of the rotation will depend on the amount of the retardation of the ray whose velocity is least ; that is to say, it will depend on the thickness of the plate of quartz. In this manner the phenomena of rotatory polarisation can be completely accounted for.

689-690. **Coloration produced by rotatory polarisation.**—The rotation is different with different colours ; its magnitude depends on the refrangibility, and is greatest with the most refrangible rays. In the case of red light a plate 1 millimetre in thickness will rotate the plane 17° , while a plate of the same thickness will rotate it 44° in the case of violet light. Hence with white light there will, in each position of the analysing Nicol's prism, be a greater or less quantity of each colour transmitted. In the case of a right-handed crystal, when the Nicol's prism is turned to the right, the colours will successively appear from the less refrangible to the more so—that is, in the order of the spectrum, from red to violet ; with a left-handed crystal in the reverse order. Obviously in turning the Nicol's prism to the left, the reverse of these results will take place.

When a quartz plate cut perpendicularly to the axis, and traversed by a ray of polarised light, is looked at through a doubly refracting prism, two brilliantly coloured images are seen of which the tints are complementary ; for their images are partially superposed, and in this position there is white light (fig. 667). When the prism is turned from left to right, the two images change colour and assume successively all the colours of the spectrum.



Fig. 667

This will be understood from what has been said about the different rotation for different colours. Quartz rotates the plane of polarisation for red 17° for each millimetre, and for violet 44° ; hence from the great difference of these two angles, when the polarised light which has traversed the quartz plate emerges, the various simple colours which it contains are polarised in different planes. Consequently, when the rays thus transmitted by the quartz pass through a double-refracting prism, they are each decomposed into two others polarised at right angles to each other : the various simple colours are not divided in the same proportion between the ordinary and extraordinary rays furnished by the prism ; the two images are, therefore, coloured ; but since those which are wanting in one occur in the other, the colours of the images are perfectly complementary.

These phenomena of coloration may be well seen by means of Norremberg's apparatus (figs. 654, 655). A quartz plate, *s*, cut at right angles to the axis and fixed in a cork disc, is placed on a screen, *e* ; the mirror *n* being then so inclined that a ray of polarised light passes through the quartz, the latter is viewed through a double-refracting prism, *g* ; when this tube is turned, the

complementary images furnished by the passage of polarised light through the quartz are seen.

691. **Rotatory power of liquids.**—Biot found that a great number of liquids and solutions possess the property of rotatory polarisation. He further observed that the deviation of the plane of polarisation can reveal differences in the composition of bodies where none is exhibited by chemical analysis. For instance, one of the two sugars obtained by the action of dilute acids on cane-sugar deflects the plane of polarisation to the right, and the other to the left, although their chemical composition is the same.

The rotatory power of liquids is far less than that of quartz. In concentrated syrup of cane-sugar, which possesses the rotatory power in the highest degree, the power is $\frac{1}{36}$ that of quartz, so that it is necessary to operate upon columns of liquids of considerable length—8 inches, for example.

Fig. 668 represents an apparatus devised by Biot for measuring the rotatory power of liquids. On a metal groove, *g*, fixed to a support, *r*, is a brass tube, *d*, 20 centimetres long, tinned inside, in which is contained the liquid

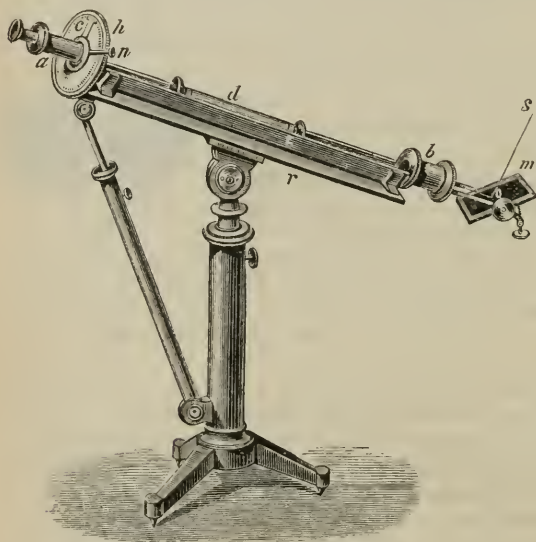

Fig. 668

experimented upon. This tube is closed at each end by glass plates fastened by screw collars. At *m* is a mirror of black glass, inclined at the polarising angle to the axis of the tubes *bd* and *a*, so that the ray reflected by the mirror *m*, in the direction *bda*, is polarised. In the centre of the graduated circle *h*, inside the tube *a*, and at right angles to the axis *bda*, is a double - refracting achromatic prism (673), which can be turned about the axis of the apparatus by means of a button *n*. The latter is fixed to a limb *c*, on which is a vernier, to indicate the number of degrees turned through. Lastly, from the position of the mirror *m* the plane of polarisation, *Sod*, of the reflected ray is vertical, and the zero of the graduation of the circle *h* is on this plane.

Before placing the tube *d* in the groove *g*, the extraordinary image furnished by the double-image prism disappears whenever the limb *c* corresponds to the zero of the graduation, because then the double-refracting prism is so turned that its principal section coincides with the plane of polarisation

(690). This is the case also when the tube d is full of water or any other *inactive* liquid, like alcohol, ether, &c., which shows that the plane of polarisation has not been turned. But if the tube is filled with a solution of cane-sugar or any other *active* liquid, the extraordinary image reappears, and to extinguish it the limb must be turned to a certain extent either to the right or to the left of zero, according as the liquid is right-handed or left-handed, showing that the polarising plane has been turned by the same angle. With solution of sugar-cane the rotation takes place to the right; and if with the same solution tubes of different lengths are taken, the rotation is found to increase proportionately to the length, in conformity with art. 687; further, with the same tube, but with solutions of various strengths, the rotation increases with the quantity of sugar dissolved, so that the quantitative analysis of a solution may be made by means of its angle of rotation.

In this experiment homogeneous light must be used; for, as the various tints of the spectrum are rotated to different extents, white light is decomposed in traversing an active liquid, and the extraordinary image does not disappear completely in any position of the double-refracting prism—it simply changes the tint. The transition tint (692) may, however, be observed. To avoid this inconvenience a piece of red glass is placed in the tube between the eye and the analyser, which only allows red light to pass. The extraordinary image disappears in that case, whenever the principal section of the prism coincides with the plane of polarisation of the red ray.

Since for a given coloured light and at a given temperature the rotation depends upon the quantity of active substance present, we may write

$$a = klr,$$

where l is the length of the tube (in centimetres), x the number of grammes of active substance per cubic centimetre of solution, and k a constant, which is called the specific rotation of the substance.

692. **Soleil's saccharimeter.**—Soleil constructed an apparatus based upon the rotatory power of liquids, for analysing saccharine substances, to which the name *saccharimeter* is applied. Fig. 669 represents the saccharimeter fixed horizontally, and fig. 670 gives a longitudinal section.

The principle of this instrument is not that of observing the angle of the rotation of the plane of polarisation, as in Biot's apparatus, but that of *compensation*; that is to say, a second active substance is used, acting in the opposite direction to that analysed, whose thickness can be altered until the contrary actions of the two substances completely neutralise each other. Instead of measuring the deviation of the plane of polarisation, the thickness is measured which the plate of quartz must have in order to produce perfect compensation.

The apparatus consists of three parts—a tube containing the liquid to be analysed, a polariser, and an analyser.

The tube m , containing the liquid, is made of copper, tinned on the inside, and closed at both ends by glass plates. It rests on a support, k , terminated at both ends by tubes, r and a , in which are the crystals, used as polariser and analyser, and which are represented in section (fig. 670).

In front of the aperture S (fig. 670) is placed an ordinary lamp. The light emitted by this lamp in the direction of the axis first meets a double-

image prism r , which serves as polariser (670). The ordinary image alone meets the eye, the extraordinary image being projected out of the field of vision in consequence of the largeness of the angle which the ordinary

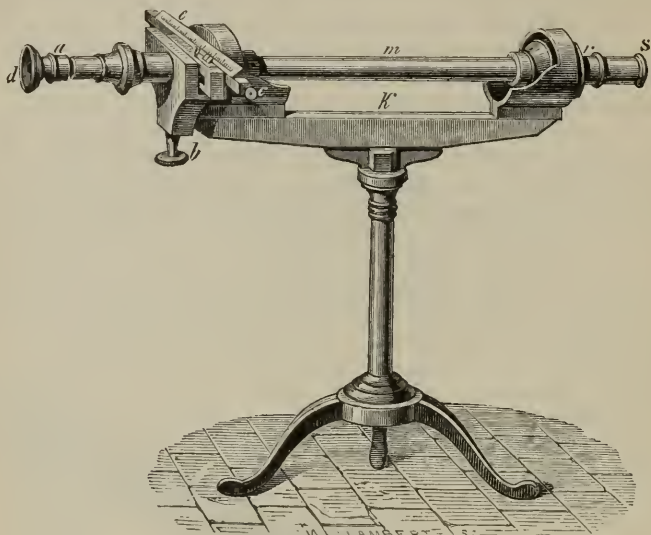

Fig. 669

makes with the extraordinary ray. This polariser is placed in such a position that the plane of polarisation is vertical, and passes through the axis of the apparatus.

Emerging from the double-image prism, the polarised ray meets a disc of quartz, called a bi-quartz, formed of two half-circles of the same thickness, but of opposite rotations, the line of separation being vertical and in the same plane as the axis of the apparatus. These plates, cut perpendicularly to the axis, have a thickness of 3.65 millimetres, corresponding to a rotation of 90° , and give a rose-violet tint, called the *tint of passage*, or *transition tint*. As the quartz, whether right-handed or left-handed, turns always to the same extent for the same thickness, it follows that the two plates a and b of the bi-quartz (fig. 673) turn the plane of polarisation equally, one to the right and the other to the left. Hence, looked at through a double-image prism, they present exactly the same tint.

Having traversed the quartz, q , the polarised ray passes into the liquid in the tube m , and then meets a single plate of quartz, i , of any thickness, the use of which will be seen presently. The compensator, n , which destroys the rotation of the column of liquid, m , consists of two quartz plates, with the same rotation either to the right or the left, but opposite to that of the plate i . These two quartz plates, a section of which is represented in fig. 671, are obtained by cutting obliquely a quartz plate with parallel sides so as to form two prisms of the same angle, N , N' ; superposing, then, these two prisms, as shown in the figure, a single plate is obtained with parallel faces, the

thickness of which can be varied at will. Each prism is fixed to a slide, so as to move either way without disturbing the parallelism, the motion being effected by means of a double rackwork and pinion turned by a milled head, *b* (figs. 669, 670).

When these plates move in the direction indicated by the arrows (fig. 671) it is clear that the sum of their thicknesses increases, and that it diminishes when the plates are moved in the contrary direction. A scale and a vernier

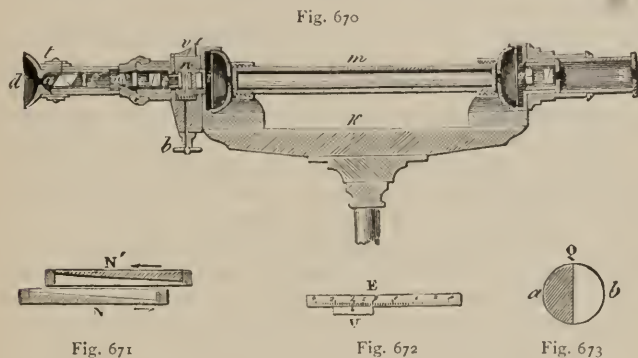

follow the plates in their motion, and measure the thickness of the compensator. This scale, represented with its vernier in fig. 672, has two divisions with a common zero, one from left to right for right-handed liquids, the other from right to left for left-handed.

When the vernier is at zero, the sum of the thicknesses of the plates *NN'* is exactly equal to that of the plate *i*, and as the rotation of the latter is opposed to that of the compensator, the effect is zero. But by moving the plates of the compensator in one or the other direction either the compensator or the quartz, *i*, preponderates, and there is a rotation from left to right.

Behind the compensator is a double-refracting prism, *c* (fig. 670), serving as analyser to observe the polarised ray which has traversed the liquid and the various quartz plates. In order to understand more easily the object of the prism *c*, we will neglect for a moment the prisms and lenses on the left of the drawing. If at first the zero of the vernier *v* coincides with that of the scale, and if the liquid in the tube is inactive, the actions of the compensator, and of the plate *i*, neutralise each other; and, the liquid having no action, the two halves of the plate *q*, seen through the prism *c*, give exactly the same tint as has been observed above. But if the tube filled with inactive liquid be replaced by one full of solution of sugar, the rotatory power of this solution is added to that of one of the halves (*a* or *b*) of the plate *q* (viz. that half which tends to turn the plane of polarisation in the same direction as the solution), and subtracted from that of the other. Hence the two halves of the plate *q* no longer show the same tint; the half *a*, for instance, is red, while the half *b* is blue. The prisms of the compensator are then moved by turning the milled head *b*, either to the right or to the left, until

the difference of action of the compensator and of the plate i compensates the rotatory power of the solution, which takes place when the two halves of the plate q , with double rotation, revert to their original tint.

The direction of the deviation and the thickness of the compensator are measured by the relative displacement of the scale e and of the vernier v . Ten of the divisions on the scale correspond to a difference of 1 millimetre in the thickness of the compensator; and as the vernier gives itself tenths of these divisions, it therefore measures differences of $\frac{1}{100}$ in the thickness of the compensator.

When once the tints of the two halves of the plate are exactly the same, and therefore the same as before interposing the solution of sugar, the division on the scale corresponding to the vernier is read off, and the corresponding number gives the strength of the solution. This depends on the experimental fact that 16.471 grains (1.067 grammes) of pure and well-dried sugar-candy being dissolved in water, and the solution diluted to the volume of 100 cubic centimetres, and observed in a tube of 20 centimetres in length, the deviation produced is the same as that effected by a quartz plate a millimetre thick. In making the analysis of raw sugar, a weight of 16.471 grains of sugar is taken, dissolved in water, and the solution made up to 100 cubic centimetres, with which a tube 20 centimetres in length is filled, and the number indicated by the vernier read off, when the primitive tint has been obtained. This number being 42, for example, it is concluded that the amount of crystallisable sugar in the solution is 42 per cent. of that which the solution of sugar-candy contained, and, therefore, 16.471 grains $\times \frac{42}{100}$, or 6.918 grains (.499 gramme). This result is only valid when the sugar is not mixed with uncrystallisable sugar or some other left-handed substance. In that case the crystallisable sugar, which is right-handed, must be, by means of hydrochloric acid, converted into uncrystallisable sugar, which is left-handed; and a new determination is made, which, together with the first, gives the quantity of crystallisable sugar.

The arrangement of prisms and lenses, $o, g, f,$ and a , placed behind the prism, c , forms what Soleil calls the *producer of sensitive tints*. For, the most delicate tint—that by which a very feeble difference in the coloration of the two halves of the rotation plate can be distinguished—is not the same for all eyes; for most people it is of a violet-blue tint, like flax blossom; and it is important either to produce this tint, or some other for which the eye of the observer is equally sensitive. This is effected by placing in front of the prism, c , at first a quartz plate, o , cut perpendicular to the axis, then a small Galileo's telescope consisting of a double convex glass, g , and a double concave glass, f , which can be approximated or removed from each other according to the distance of distinct vision of each observer. Lastly, there is a double-refracting prism, c , acting as polariser in reference to the quartz, and the prism a as analyser; and hence, when the latter is turned either right or left, the light which has traversed the prism c , and the plate o , changes its tint, and finally gives that which is the most delicate for the experimenter.

693. **Polarisation of heat.**—The rays of heat, like those of light, may become polarised by reflection and by refraction. The experiments on this subject are difficult of execution; they were first made by Malus and

Berard in 1810 ; after the death of Malus they were continued by the latter philosopher.

In his experiments, the heat rays reflected from one mirror were received upon a second, just as in Norremberg's apparatus ; from the second they fell upon a small metallic reflector, which concentrated them upon the bulb of a differential thermometer. Berard observed that heat was not reflected when the plane of reflection of the second mirror was at right angles to that of the first. As this phenomenon is the same as that presented by light under the same circumstances, Berard concluded that the heat rays became polarised in being reflected.

The double refraction of heat may be shown by directing the sun's rays by means of a heliostat on a prism of Iceland spar, and investigating the resultant pencil by means of a bolometer or of a thermopile, which must have a sharp narrow edge. In this case also there are an ordinary and an extraordinary ray, which follow the same laws as those of light. In the optic axis of the calcspar, heat is not doubly refracted. A Nicol's prism can be used for the polarisation of heat as well as for that of light : a polarised ray does not traverse the second Nicol if the plane of its principal section is perpendicular to the vibrations of the ray. The phenomena of the polarisation of heat may also be studied by means of plates of tourmaline and of mica. The angle of polarisation is virtually the same for heat as for light. In all these experiments the prisms must be very near each other.

The diffraction, and therefore the interference, of rays of heat has been established by the experiments of Knoblauch and others. And Forbes, who repeated Fresnel's experiment with a rhombohedron of rock salt, found that by two total internal reflections, heat is circularly polarised, just as is the case with light.

BOOK VIII

ON MAGNETISM

CHAPTER I

PROPERTIES OF MAGNETS

694. **Natural and artificial magnets.**—*Magnets* are substances which have the property of attracting iron, and the term *magnetism* is applied to the cause of this attraction and to the resulting phenomena.

The property exists in a high degree in an ore of iron which is known in chemistry as the *magnetic iron oxide*. Its composition is represented by the formula Fe_3O_4 .

This mineral, which is also called *lodestone*, was first found at Magnesia, in Asia Minor, the name magnet being derived from this circumstance. The name lodestone, which is applied to this natural magnet, was given on account of its being used when suspended as a guiding or leading stone, from the Saxon *lædan*, to lead ; so also the word *lodestar*. Lodestone is met with in the older geological formations, especially in Sweden and Norway, where it is worked as an iron ore, and furnishes the best quality of iron.

A piece of steel may, by suitable means, which will be presently described, have this property of attracting iron conferred upon it ; it then becomes an *artificial magnet*. Artificial magnets can be made more powerful than natural magnets, and, as they are also more convenient, they will be exclusively referred to in describing the phenomena of magnetism. They may be made of any shape : a *bar magnet* is a rectangular strip with square ends, say eight or ten inches long, an inch broad, and an eighth of an inch thick ; it becomes a horseshoe magnet when its ends are bent round towards each other. A *magnetic needle* is a thin strip of magnetised steel with pointed ends, suspended by a string, or supported on a pivot, in such a way that it can turn in a horizontal plane ; it is often called a *compass needle*.

695. **Poles and neutral lines.**—When a small piece of soft iron is suspended by a thread and a bar magnet is approached to it, the iron is attracted towards the magnet, and some force is required for its removal. The force of the attraction varies in different parts of the magnet ; it is strongest at the two ends, and is totally wanting in the middle.

This variation may also be seen very clearly when a bar magnet is placed in iron filings (fig. 674); the filings cling round the ends of the bar in feathery tufts, diminishing in amount towards the middle, where there are none. That part of the surface of the bar which is free from filings is called the *neutral line* or *neutral plane*; and the parts near the ends of the bar where the attraction is greatest are called the *poles* (716). Every mag-

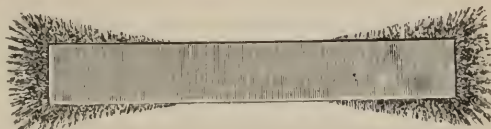

Fig. 674

net, whether natural or artificial, has two poles and a neutral line. The experiment of the iron filings shows that the two ends of the magnet are exactly alike in their action on the filings, there being nothing to indicate any difference between them. But a magnet, suspended by a string in such a way that it can move in a horizontal plane, is found to come to rest after some oscillations in nearly a north and south position, one particular end pointing to the north. We must therefore distinguish one end of a magnet from the other. The end which points to the north is called the *north* or *red pole*, the other being the *south* or *blue pole*.

696. **Reciprocal action of two poles.**—When a small magnetic needle, *ab* (fig. 675), is suspended by a fine thread, and the north pole, *A*, of another needle is brought near its north pole, *a*, repulsion takes place. If, on the contrary, *A* is brought near the south pole, *b*, of the movable needle, the latter is strongly attracted. It may be shown in the same manner that the two poles of the magnet *A* are also different, by successively presenting them to the same pole, *a*, of the movable needle. In one case there is repulsion, in the other attraction. Hence the following law may be enunciated:—

Poles of the same name repel, and poles of contrary names attract, one another.

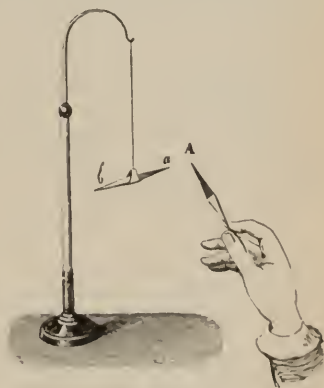

Fig. 675

The setting of a magnetic needle north and south would be intelligible in the light of the above law, if there were in the northern regions of the earth a magnet pole—a blue pole—attracting the red end of the needle and repelling the blue end, and in the southern part of the earth a red pole attracting the blue and repelling the red end of the needle; in other words, if the earth were a natural magnet with blue polarity in the Arctic and red polarity in the Antarctic regions, and we know that the earth is such a magnet.

Faraday called the north end of a magnet the *marked end*, and distinguished it by a transverse notch, the other end being the *unmarked end*. Lord Kelvin calls the end which points to the north the *true south pole*, and the end which points to the south the *true north pole*. Such nomenclature

is liable to cause confusion. Sir George Airy introduced the names *red* and *blue*. For practical purposes Lord Kelvin has adopted these names; he paints the magnets which are used for the correction of ship's compasses half red and half blue. On the same principle the earth's magnetism would be represented by a globe painted blue in the northern and red in the southern hemisphere. We shall call the end of a magnet which points to the north the *red* or *north* pole indifferently, except when we are dealing with the earth's magnetism, in which case blue and red are preferable terms.

697. **Experiments with broken magnets.**—We have seen that the two halves of a bar magnet have opposite polarities, although the action is greatest at the ends, and diminishes to zero at the centre. We might hence expect that if a magnet were broken in two, each half would retain the magnetism it possessed in the unbroken bar, and so exhibit polarity of one kind only. That this is not so, but that each of the broken parts possesses all the properties of a complete magnet, is evident from the following experiment:—A steel knitting-needle (fig. 676) is magnetised by rubbing it with one of the poles of a magnet, and then, the existence of the two poles A, B, and of the neutral line N having been ascertained by means of iron filings, it is broken in the middle. But now, on presenting successively the two halves to a magnet, each will be found to possess two opposite poles A, B', and A', B, with a neutral line N, and to be in fact a perfect magnet. If these new magnets are broken in turn into two halves, each will be a complete magnet AB'' and A''B' with its two poles and neutral line, and so on, as far as the division can be continued.

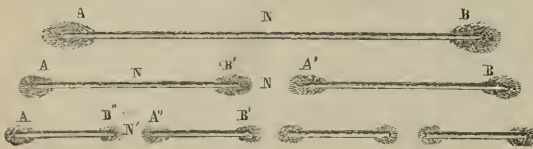

Fig. 676

Further, the piece A''B' from near the centre is just as strong as the piece AB'' near the end. If the magnetised knitting-needle is

converted into filings, each bit is still a perfect magnet. In imagination we may carry the division further, and assert that when the attenuation has gone so far that the molecule is reached, each ultimate particle contains the two magnetisms; that magnetism, in short, is a phenomenon the cause of which resides in the elementary particle or molecule itself. Each molecule is a magnet. It follows also from this experiment that it is impossible to obtain one pole of a magnet without the other, in other words that *unipolar* magnets have no existence. In practice, however, and for experimental purposes, we may assume that one end of a magnet, the length of which is 50 times its diameter, acts as an *isolated* or *single* pole.

698. **Theories of magnetism.**—To explain the phenomena, it was usual at one time to assume the existence of hypothetical magnetic fluids each of which acts repulsively on itself, but attracts the other fluid, and to imagine each molecule of the magnetic substance in the unmagnetised state to be surrounded by equal quantities of the two fluids, so as to mutually neutralise each other. The fluids could be more or less separated from each other by the action of magnetising forces, but were not able to leave the molecule.

The fluids were completely separated when the substance was magnetised to saturation.

Another way in which the phenomena may be regarded is to suppose every particle of a magnetic substance such as iron to be intrinsically a magnet having a north (or red) pole at one end, and a south (or blue) pole at the other end. In the unmagnetised bar these molecular magnets have their axes pointing in directions depending on their mutual actions, and the bar exhibits no resultant external magnetic effect, since, on the whole, the particles point as much in one direction as in another. When, however, the bar is subjected to an external magnetic force, the molecular magnets tend to be twisted round into the direction of magnetisation, which tendency is greater the greater the applied force. If the applied force is so great that all the tiny magnets have their axes brought completely round into the direction of the force, the bar is magnetised to saturation. We need not trouble ourselves with the question as to how the molecules of a magnetic substance become magnets. We have only to suppose that the magnetic character of each molecule is an inherent and permanent property of the substance, like its hardness, or opacity, or electric conductivity.

This mode of regarding what takes place in a magnetic substance when it is magnetised may be illustrated by nearly filling a glass tube with steel magnetised filings, obtained by filing up a steel magnet. The tube will be found to behave like a rod of iron, showing no polarity. But if the particles are shaken while being subjected to a strong magnetic force, if for instance the tube, held vertically, be sharply tapped against the south pole of a strong bar magnet, so that the filings are more or less free to move at the moment when they are acted upon by a downward magnetic force, it will be found that the tube has become a permanent magnet, with a north pole at the bottom and a south pole at the top. The effect of the applied force has been to draw downwards to a greater or less extent the north poles of the filings. But on shaking the tube, or turning out the filings, and putting them in again so as to destroy the regularity, every trace of polarity will disappear. It seems therefore that the polarity at each end of a magnet is caused by the fact that the resultant action on a magnetic body is strongest near the ends, and does not arise from any accumulation of magnetisms at the ends. Rupture of the glass tube may be guarded against by placing a piece of cloth on the bar magnet.

The same point may be illustrated by the following experiment, which is due to the late Sir W. Grove:—In a glass tube with plate glass ends is placed water in which is diffused magnetic oxide of iron. Round the outside of the tube is coiled some insulated wire. When the tube is shaken the liquid appears dark and muddy by transmitted light, but becomes clearer when a current of electricity is passed through the wire. This is due to the fact that by the magnetising action of the current the magnetic particles set with their longest dimension parallel to the axis of the tube, in which position they obstruct the passage of light to a less extent.

The ultimate particles of a piece of iron are not in absolute contact with each other. We are assured of this by the fact that the volume of an iron rod diminishes when its temperature falls. Hence the ultimate particles have

a certain freedom of motion. Joule showed that when a bar of iron is magnetised it is increased in length, which is accounted for by supposing that the molecular magnets turn round with their magnetic axes in the direction of magnetisation. The more recent experiments of Mr. Shelford Bidwell will be described later (906).

699. **Magnetic field. Lines of force.**—The space round a magnet through which it exercises its property of attracting or repelling a magnetic pole is called the *magnetic field due to the magnet*. The magnetic field is pervaded by magnetic force, so that if a magnetic pole is placed at any point in it, the pole begins to move in a definite direction, which is the direction of the force at the point. A red pole would move in one direction, a blue pole in the opposite, and a small compass needle would *set* so as to show the direction of the line of force at the point. Thus, if a small magnet about an inch long is pivoted on a point and put on a table on which a bar magnet is supported, the needle and magnet being in the same horizontal plane, the needle shows the direction of the magnetic force, which in this case is due jointly to the bar magnet and to the earth. By gradually moving the little needle in the direction in which it points, a line is traced which indicates at any point the direction of the resultant magnetic force. If we repeat the operation, starting at some fresh point, we trace another *line of magnetic force*, and so the whole field, or rather the horizontal section of it in which the exploring needle moves, may be mapped out. Near the poles of the bar magnet the exploring needle points directly towards the pole; at places equidistant between the poles it lies parallel to the bar. The general appearance of the lines of force, as thus traced, is shown in fig. 679. The intensity of the magnetic force is greatest near the poles, and diminishes as the distance increases. By the term *strength of a field at a point* is meant the intensity of the magnetic force at that point.

700. **Magnetic induction.**—A rod of iron introduced into a magnetic field at once becomes a magnet, and is said to be *magnetised by induction*, its magnetism being *induced magnetism*. When the iron is removed from the field, as a rule the induced magnetism disappears and the rod ceases to have any magnetic polarity. The amount of the induced magnetism is greater when the rod is parallel to the lines of force than when it lies across them, and is greatest when it is in contact with one end, say the north pole, of the bar; the rod, if not too large, will then be supported by the magnet, and will itself be a magnet, as may be tested by iron filings, with south

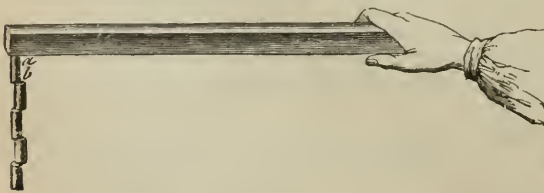

Fig. 677

pole at the top and north pole at the bottom, and remain so as long as the contact continues. This rod will support a second, and that a third, and so on (fig. 677), the

magnetic attraction becoming feebler as the distance from the bar increases. Each of these rods has become a magnet by induction, with a south pole at the top and a north pole below. But they are magnets only so long as they

remain under the influence of the bar ; when removed from it they lose all their polarity.

The formation of the tufts of iron filings which become attached to the poles of magnets is due to induction. The particles in contact with the magnet are converted into magnets ; these act inductively on the adjacent particles, and these on the next, and so on, producing a filamentary arrangement of filings. The bush-like appearance of these filaments is due to the repulsive action which the free poles exert upon each other. Any piece of magnetic substance like iron, while being attracted by a magnet, is for the time being converted into a magnet. Magnetic action can only take place between magnets, not between a magnet and a piece of matter.

Fig. 678 illustrates the effect of superposing two magnetic fields. A is the north pole of a bar magnet to which a piece of iron, a key for example, is attached, being rendered a magnet by induction, with a south pole at the top. When a second similar magnet is slid over the first with its south pole B gradually approaching the north pole A, the magnetism induced in the key is weakened and the key presently falls. Two magnets placed in contact with opposite poles together produce practically no external field, that is, iron is not magnetised in their neighbourhood.

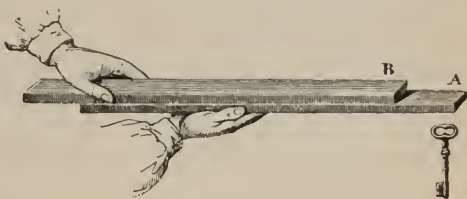

Fig. 678

The distribution of magnetic force in the field due to a bar magnet may be well shown by means of iron filings, since these become magnets when introduced into the field. If a stout sheet of paper stretched on a frame is held over a bar magnet, and then some very fine iron filings are strewn on the paper, on tapping the frame the filings will be found to arrange themselves in thread-like curved lines, stretching from pole to pole (fig. 679). These lines form what are called *magnetic curves*. The direction of the curve at any point represents the direction of magnetic force at this point.

To render these curves permanent, the paper on which they are formed should be waxed ; if then a hot iron plate is held over them, the wax is melted, and rises by capillary attraction (132) between the particles of filings, and, on subsequent cooling, connects them together. They may also be fixed by carefully placing on

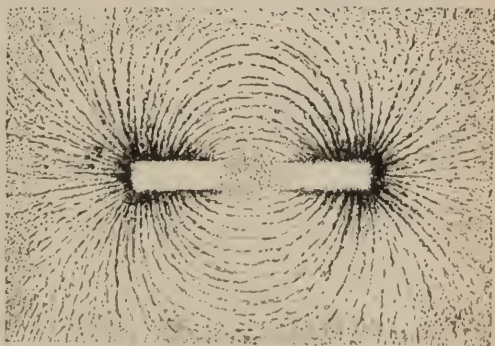

Fig. 679

a hot iron plate is held over them, the wax is melted, and rises by capillary attraction (132) between the particles of filings, and, on subsequent cooling, connects them together. They may also be fixed by carefully placing on

them a sheet of paper coated with paste, which is then gently pressed and lifted off: it should be quickly dried to prevent the iron from rusting.

These curves are a graphic representation of the law of magnetic attraction and repulsion with regard to distance; for under the influence of the two poles of the magnet each particle becomes itself a minute magnet, the poles of which arrange themselves in a position dependent on the resultant of the forces exerted upon them by the two poles, and this resultant varies with the distance of the two poles respectively. A small magnetic needle placed in any position near the magnet will take a direction which is the tangent to the curve at this place.

We must picture to ourselves a permanent magnet as having permanently associated with it a definite set of lines of force, which are not merely bound up with the fact that their existence is revealed by iron filings. Lines of force must be conceived as acting like stretched elastic threads repelling each other in a direction at right angles to their lengths. An illustration of this is furnished by suspending two long thin magnetised needles from threads at the ends; when these are brought near each other, with like poles opposite, the direction of the lines of force is the same in each, and the needles repel each other. In fig. 680 the magnetic curves represent the direction of the lines of force in the field due to two opposite poles,

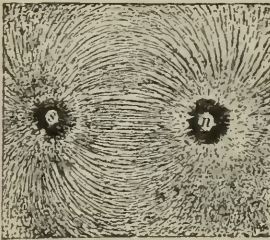

Fig. 680

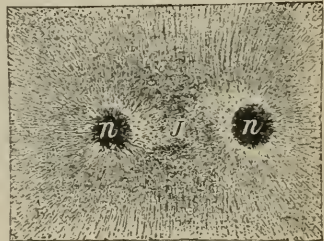

Fig. 681

while fig. 681 represents that due to two similar poles, both figures being taken from photographs of actual fields.

The expression 'lines of force' or 'lines of magnetic force' is used in much the same sense as that in which we speak of rays of light. And just as we might express the illumination of any surface by the number of rays which fall upon it, so also we may say that the strength of the magnetic field at any point is proportional to the number of lines of force which pass through a given area placed transversely to the lines and enclosing the point.

A *uniform magnetic field* is one in which the lines of force are parallel and uniformly distributed. This is practically the case with a small portion of the field at a considerable distance from the pole of a magnet, or between the poles of a horseshoe magnet. It is also the case in the interior of a long magnetising coil (901) except near the ends.

The direction of a line of force is the direction in which a red pole would move along the line; it is usual to speak of the lines as starting at the north pole and ending at the south pole. It will be seen later that we must

regard a line of force, not as starting at one point and ending at another, but as a continuous line running through the substance of the magnet. Fig. 679 shows only the external portions of the lines, but each of these has its counterpart in the steel itself, so that the lines run in the magnet from the south to the north pole, and externally from the north to the south. If the bar is very long in comparison with its cross section, the lines emerge and enter at the ends only; but with an ordinary bar magnet the lines escape before they reach the end, as is indicated by the smaller curves in fig. 679. When a bar magnet is plunged into filings none of them cling to the centre, because no lines of force escape there; where lines of force escape, there filings cling. Hence all the lines associated with a magnet pass through the middle: here they are parallel, but they diverge towards the ends and complete the magnetic circuit outside.

701. **Magnetic substances.**—Iron is not the only substance which is attracted by a magnet. Nickel and cobalt exhibit the same property, and, to a less degree, manganese. Faraday showed that there are a great many other substances which are also magnetic; but in them the attraction is so feeble that special means must be employed to show it. Again, there are other substances which are repelled instead of attracted by a magnet, bismuth being the most noteworthy; such substances are said to be *diamagnetic*. Thus, as regards magnetic properties, all substances may be put into one of three classes:—

1. *Ferromagnetic substances*, or those which are strongly acted on by a magnet. These are iron, nickel, cobalt, and, to a less extent, manganese, at ordinary temperatures; alloys of iron with carbon (different kinds of steel) and other substances, and salts of iron. Some alloys of iron are almost non-magnetic and should be put into class 2. They all contain manganese.

2. *Paramagnetic substances*.—These are also attracted by a magnet, but so slightly that the action cannot be observed except under special conditions. In this class are the metals platinum and aluminium, many salts, oxygen and ozone, and the ferromagnetic metals, iron, nickel, and cobalt, when heated above their critical temperatures (712).

3. *Diamagnetic substances*, or those which are repelled by the pole of a magnet. A rod of a diamagnetic substance tends to place itself at right angles to the lines of force in a magnetic field, as a rod of iron places itself *along* the lines of force. Among diamagnetic substances are bismuth, phosphorus, antimony, water, and many gases. The subject of Diamagnetism is treated in Book X. Chapter XIII.

Magnetic substances have no action on each other. If a rod of iron is dipped into filings none of them adhere; but if the rod is brought near to one of the poles of a compass needle the pole is *attracted* and the needle deflected. This is due to the fact that when the rod is brought into the magnetic field of the needle it becomes a magnet by induction. The end nearest to the north pole of the needle becomes the south pole, and so attraction ensues; but the magnetism comes and goes quite freely owing to the small coercive force (702) of the iron, so that when the same end is presented to the south pole of the needle it becomes a north pole, and again attraction occurs. If the iron rod had been a magnet, either end of it would have attracted one end of the needle, and repelled the other. Thus the

phenomenon of repulsion enables us to determine when a rod of iron or steel has or has not any permanent magnetism. But this is sometimes misleading ; for instance, if a rod of iron has a certain very small amount of permanent magnetism it may repel one of the poles of a magnet at a certain distance, but attract it when brought nearer, owing to the induced magnetism overpowering the small amount of permanent magnetism. The best way of testing a rod of magnetic substance for a trace of permanent magnetism is to place it at right angles to the magnetic meridian (727), so that its end is equidistant from the two poles of a small sensitive compass needle. Under these conditions it will have no magnetism induced in it by the needle, and therefore if it is free from permanent magnetism the needle will not be deflected. A deflection of the needle must be due to permanent magnetism in the rod.

702. **Coercive force.**—We have seen from the above experiments that soft iron becomes magnetised under the influence of a magnet, but that this magnetism is not permanent, and ceases when the magnet is removed. Steel likewise becomes magnetised when near to a magnet ; but to a much less extent, and the less as the steel is more highly tempered. Placed in contact with a magnet, a steel bar acquires magnetic properties to a slight extent only ; to make the magnetism more powerful the steel must be rubbed with one of the poles. But the greater part of the magnetism thus evoked in steel is permanent, and does not disappear when the inducing force is removed.

These different effects in soft iron and steel are ascribed to a kind of resistance, analogous to friction, which is called *coercive force*, and which, in a magnetic substance, offers a hindrance to the rotation of the molecular magnets, but which also prevents their return to their former positions when once moved. In steel this coercive force is very great ; in soft iron it is very small or almost absent. By oxidation, stretching, pressure, torsion, or hammering, a certain amount of coercive force may be imparted to soft iron ; and by heat the coercive force may be lessened, as will be afterwards seen.

CHAPTER II

METHODS OF MAGNETISATION

703. **Magnetisation.**—There are various methods by which the ferromagnetic substances—iron, steel, nickel, and cobalt—may be converted into magnets. We have already seen that a piece of iron becomes a magnet, by induction, when brought into a magnetic field, and that the amount of magnetism induced is greatest (for a given position in the field) when the iron lies along the lines of force. But the magnetism thus produced is as a rule not permanent. The principal methods of converting a bar of steel into a permanent magnet are (1) those known by the technical names of *single touch*, *separate touch*, and *double touch*, and (2) those in which an electric current is employed.

704. **Method of single touch.**—This consists in moving the pole of a powerful magnet from one end to the other of the bar to be magnetised, and repeating this operation several times always in the same direction. The molecular magnets are thus gradually rotated throughout all the length of the bar, and that end of the bar which was touched last by the magnet is of opposite polarity to the end of the magnet by which it has been touched. This method only produces a feeble magnetic power, and is, accordingly, only used for small magnets.

705. **Method of separate touch.**—This method, which was first used by Dr. Knight in 1745, consists in placing the two opposite poles of two equally strong magnets in the middle of the bar to be magnetised, and then moving them simultaneously towards the opposite ends of the bar. Each magnet is then placed in its original position and the operation repeated. After several rubbings on both faces the bar is magnetised.



Fig. 682

In Knight's method the magnets are held vertically. Duhamel improved the method by inclining the magnets, as represented in fig. 682; and still more by placing the bar to be magnetised on the opposite poles of two fixed

magnets, the action of which strengthens that of the movable magnets. If all the magnets are arranged in the magnetic meridian with their north poles (A) towards the north, additional advantage is gained from the inductive action of the earth's magnetism. The relative position of the poles of the magnets is indicated in the figure. This method produces the most regular magnets.

706. **Method of double touch.**—In this method, which was invented by Mitchell, the two magnets are placed with their opposite poles together in the middle of the bar to be magnetised. But, instead of being moved in opposite directions towards the two ends, as in the method of separate touch, they are kept at a fixed distance by means of a piece of wood placed between them (fig. 682), and are simultaneously moved first towards one end, then from this to the other end, the operation being repeated several times, and finished in the middle, care being taken that each half of the bar receives the same number of strokes.

Epinus, in 1758, improved this method by supporting the bar to be magnetised, as in the method of separate touch, on the opposite poles of two powerful magnets, and by inclining the bars at an angle of 15° to 20° . In practice, instead of two bar magnets, it is usual to employ a horseshoe magnet which has its poles conveniently close together.

Whichever of the above three methods is employed, it will be found that, after five or six rubbings on each side, the bar has received as much magnetism as can be imparted to it by the particular method employed. This can be tested by placing the bar on a table at right angles to the magnetic meridian, at the distance of about 40 or 50 cm. from a small compass needle. The deflection of the needle, which is a measure of the magnetism of the bar, increases with the number of rubbings up to five or six, but not beyond.

If in the method of separate or double touch two *similar* poles are used, two red poles for example, the result is that the steel bar acquires a blue pole at each end and a red pole in the middle. The magnet is then said to have *consequent poles*.

In the method of double touch, even when two unlike poles are used, it often happens that consequent poles are developed. Hence this method is not in general so satisfactory as that of separate touch.

707. **Magnetisation by electricity.**—In the methods of touch described above, the bar of steel was magnetised by suitably agitating its particles when it was in the field of the magnet or magnets employed, and the amount of induced magnetism was limited by the strength of these magnets. If stronger magnets are used, or if by other means the strength of the magnetic field surrounding the steel is increased, more magnetism may be induced. A bar of steel is said to be magnetised to saturation when its magnetism cannot be increased by any possible means. On the molecular-magnet theory we see that this condition will be reached when the molecules are turned round so that their magnetic axes are all parallel to the direction of magnetisation, that is, to the length of the bar.

An electric current supplies us with the most satisfactory means of applying a magnetic field. A tube made of brass or glass or other non-magnetic material is wound with from ten to twenty turns per cm. of insulated

copper wire, the ends of which terminate in binding screws as represented at A (fig. 966). When a current from a battery passes through this coil a magnetic field is produced inside and all round it, but the field is strongest in the hollow of the tube where the lines of force are parallel to the length of the tube. The strength of the field depends upon two things, viz. the number of turns of wire in the coil and the strength of the electric current, that is, upon the number of *ampere-turns* (902). Thus for a given coil we can, by increasing the current, make the field as strong as we wish.

The bar of steel to be magnetised is placed inside the coil, and on removal, after the circuit has been broken and completed several times, is found to be strongly magnetised.

708. **Magnetic battery.**—A *magnetic battery* consists of a number of magnets joined together by their similar poles. Sometimes they have the form of a horseshoe, and sometimes a rectilinear form. The battery represented in fig. 683 consists of five superposed steel plates. That in fig. 684 consists of twelve plates, arranged in three layers of four each. The horseshoe form is best adapted for supporting a weight, for then both poles are used at once. In both the bars are magnetised separately, and then fixed by screws.

The force of a magnetic battery consisting of n similar plates equally magnetised is not n times as great as that of a single one, but is somewhat smaller. These magnets mutually enfeeble each other; manifestly because each north pole evokes south magnetism in the adjacent north pole, and thereby diminishes some of its north polarity. At the same time the strength is greater than if the steel is in one coherent mass; the reason doubtless is that thin plates of steel are more easily magnetised to saturation than thick ones, as the inducing action does not extend deep. The separate plates should not be in contact, as the enfeeblement of the magnetism is thereby less. It is also advisable to connect the pieces by a mass of soft iron as shown in fig. 684. The magnetism of a plate which has formed part of such a battery will be found to be materially less than it was originally. Thus Jamín found that six equal plates, which separately had each the portative force (710) of 18 kilos., only lifted 64 kilos.

when arranged as a battery, instead of 108; and when removed from the battery, each of them had only the portative force 9 to 10 kilos. The force is increased by making the lateral plates 1 or 2 centimetres shorter than the one in the middle (fig. 683).

709. **Armatures.**—When steel bars have been magnetised by any of the methods described above, they tend gradually to lose their magnetism. To

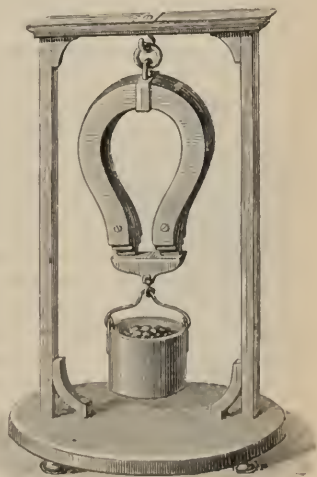

Fig. 683

prevent this, *armatures* or *keepers* are used; these are pieces of soft iron, AB, AB (fig. 685), which are placed in contact with the poles of a horseshoe magnet, or with the opposite poles of a pair of bar magnets. Acted on inductively, they become powerful temporary magnets, possessing opposite polarity to that of the inducing pole; they thus react in turn on the permanent magnetism of the bars, preserving and even increasing it. The lines of force between opposite poles, instead of spreading out in air in widely extended curves, are now for the most part confined to the soft iron keepers, and there is comparatively little external field. Iron is more *permeable* to lines of force than air (721).

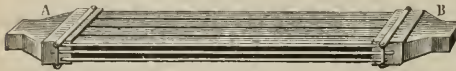

Fig. 684



Fig. 685

A horseshoe magnet has a keeper attached to it, which is usually arranged so as to support a weight. The keeper becomes magnetised under the influence of the two poles, and adheres with great force: the weight which it can support being more than double that which a single pole would hold (fig. 683).

In respect to this weight, a singular phenomenon has been observed. When contact is once made, and the keeper is charged with its maximum weight, any further addition would detach it; but if left in contact for a day, an additional weight may be added without detaching it, and by slightly increasing the weight every day it may ultimately be brought to support a far greater load than it would originally. But if contact be once broken, the weight it can now support does not much exceed its original charge.



Fig. 686

It is advantageous that the surface of the magnet and armatures which are in contact should not be plane but very slightly cylindrical, so that they touch along a line.

In providing a natural magnet with a keeper, the line joining the two poles may first be approximately determined by means of iron filings; it may also be determined by bringing it near a magnetic needle, and ascertaining the positions in which its action is greatest.

Two poles of soft iron (fig. 686), each terminating in a massive shoe, are then applied to the faces corresponding to the poles. Under the influence of the natural magnet, these plates become magnetised, and if the letters A and B represent the position of the poles of the natural magnet, the poles of the armature are *a* and *b*.

710. *Portative force*.—The *portative force* is the greatest weight which a magnet can support. It can be determined by suspending to the keeper a vessel to which shot or sand or water is gradually added, until the keeper is detached (fig. 683). Häcker found that the portative force of a saturated

horseshoe magnet, which, by repeatedly detaching the keeper, had become constant, may be represented by the empirical formula

$$P = a\phi^{\frac{2}{3}},$$

in which P is the portative force of the magnet, ϕ its own weight, and a a coefficient which varies with the nature of the steel and the mode of magnetising. Hence a magnet which weighs 1000 ounces supports only 25 times as much as one weighing 8 ounces or $\frac{1}{125}$ as heavy, and 25 such bars would support as much as a single one which is as heavy as 125 of them. It appears immaterial whether the section of the bar is quadratic or circular, and the distance of the legs is of inconsiderable moment; it is important, however, that the magnet be suspended vertically, and that the load be exactly in the middle. In Häcker's magnets the value of a was 10.33; while in Logemann's it was 23. By arranging together several thin magnetised plates Jamin constructed bar magnets which supported 15 times their own weight.

The attraction between the plane pole face of a magnet and an iron armature in contact with it may be shown to be $\frac{B^2S}{8\pi}$, where S is the area of the surfaces in contact and B the magnetic induction (721), that is the number of lines of force per square centimetre of the surfaces.

In the case of a horseshoe magnet the surface S is that of both limbs.

711. Circumstances which influence the power of magnets.—All bars do not attain the same magnetic state under the same magnetising forces, for their coercive force varies. Twisting or hammering imparts to iron or steel a considerable coercive force. But the most powerful of these influences is the operation of tempering (93). Coulomb found that a steel bar tempered at dull redness, and magnetised by a given field, made ten oscillations in 93 seconds. The same bar tempered at a cherry-red heat, and similarly magnetised, took only 63 seconds to make ten oscillations.

Hence it would seem that the harder the steel the greater is its coercive force; it undergoes magnetisation less readily, but retains it more effectually. It appears, however, from Jamin's experiments that no general rule of this kind can be laid down; for each specimen of steel there seems, according to the proportion of carbon which it contains, to be a certain degree of tempering which is most favourable for the development of permanent magnetisation.

Very hard steel bars have the disadvantage of being very brittle, and in the case of long thin bars a hard tempering is apt to produce consequent poles (706). Compass needles are usually tempered at a blue heat—that is, about 300° C.—by which a high coercive force is obtained without great fragility. The steel rods used by Lord Kelvin for compass correction are made as hard as possible; before being magnetised they are raised to a bright red heat and quenched in cold water.

The hardness of steel, and the proportion of carbon which it contains, exert an important influence on the degree to which it can be permanently magnetised. For the same degree of hardness, the retained magnetism increases with the proportion of carbon in the steel. Holtz magnetised plates

of English corset steel to saturation and determined their magnetic moment; they were then placed in dilute hydrochloric acid, by which the iron was eaten away, and the magnetic moment determined when the plate had been magnetised to saturation after each such treatment. It was thus found that, with a diminution in the proportion of iron, there was an increase in the magnetic moment for the unit of weight. Holtz found, however, that perfectly pure iron prepared by electrolysis can acquire permanent magnetism. Ferromanganese, or iron alloyed with about 12 per cent. of manganese, is quite destitute of magnetic properties. Hopkinson showed that nickel steel containing 25 per cent. of nickel and a small percentage of carbon is magnetic or non-magnetic at ordinary temperatures, depending on its previous treatment. If a specimen of magnetic nickel steel is raised to a sufficiently high temperature it loses its magnetic susceptibility (722), and does not regain it on cooling, so that at ordinary temperatures it is now non-magnetic. It recovers, however, its capacity for being magnetised if cooled down to -20° C.

Jamin found that magnetisation extends deeper in a bar than has been usually supposed; in soft and annealed steel it penetrates deeply. The depth diminishes with the hardness of the steel and the proportion of carbon it contains.

Holtz made some experiments on the influence of solid bars as against hollow tubes in the construction of permanent steel magnets. The latter are to be preferred; they are decidedly cheaper, as they need not be bored, but may be bent from steel plates. A bar and a tube of the same steel, 125 mm. in length by 13 mm. diameter, the tube being 1.75 mm. thick, were magnetised to saturation, and the magnetic moments determined by the method of oscillation (719), the tube being loaded with copper to make its moment of inertia the same as that of the solid magnet (89A). The magnetism of the tube was to that of the bar as 1.6 : 1. The tubes also retained their magnetisation better. After the lapse of six months the ratio of the magnetism of the tube to that of the bar was as 2.7 : 1. A magnetised steel tube filled with a soft iron core has scarcely any directive force. Holtz considers that the iron acts as a keeper.

Percussion and torsion.—When a steel bar is hammered while being magnetised it acquires a much higher degree of magnetisation than it would without this treatment. Conversely when a magnet is let fall, or is otherwise violently disturbed, it loses some of its magnetisation. Wiedemann has investigated in a very complete manner the relations of torsion and magnetisation. Torsion exerts a great influence on the magnetisation of a bar, and the interesting phenomenon has been observed that the influence of torsion on magnetism is reciprocal. Thus the permanent magnetisation of a steel bar is diminished by torsion, but not proportionately to the increase of torsion. In like manner the torsion of twisted iron wires is diminished by their being magnetised, though less so than in proportion to their magnetisation. Repeated torsions in the same direction scarcely diminish magnetisation, but a torsion in the opposite direction produces a new diminution of the magnetism. In a perfectly analogous manner, repeated magnetisations in the same direction scarcely diminish torsion, but a renewed magnetisation in the opposite direction does so.

712. **Effect of temperature.**—Increase of temperature always produces a diminution of the magnetism of a steel magnet. If the changes of temperature are small—those of the atmosphere, for instance—the magnet is not permanently altered. Kuppfer allowed a magnet to oscillate, in the earth's field, at different temperatures, and found a definite decrease in its moment with increased temperature, as indicated by its slower oscillations. In the case of a magnet $2\frac{1}{2}$ inches in length, he observed that with an increase of each degree of temperature the duration of 800 oscillations was 0.4 second longer. If n is the number of oscillations at zero, and n_1 the number at t , then

$$n = n_1 (1 - ct),$$

where c is a constant depending in each case on the magnet used. This formula has an important application in the correction of the observations of magnetic force which are made at different places and at different temperatures, and which, in order to be comparable, must first be reduced to a uniform temperature.

When a magnet has been more strongly heated, it does not regain its original moment (720) on cooling to its original temperature; and when heated to bright redness, it is demagnetised. This was first shown by Coulomb; it is the most satisfactory method of demagnetising a steel magnet. The magnet, after being heated to bright redness (about 800° C.), may be cooled either slowly or rapidly, but in either case it should be held in such a position as not to be subjected to any magnetic force.

Substances which are ferromagnetic at ordinary temperatures lose their magnetic quality, or rather become paramagnetic (701), like copper, &c., when their temperature is sufficiently raised. Gilbert showed that at a red heat iron is incapable of being magnetised. As the temperature of iron is raised the susceptibility slightly increases, but falls suddenly to zero when the temperature reaches 790° . The point at which this sudden loss of magnetic quality occurs is called the *critical temperature* for the particular metal. The critical temperature of nickel is 350° ; for cobalt it is above a white heat. The suddenness with which iron loses its magnetic quality depends upon the intensity of the field. In a very feeble field the magnetic susceptibility rises to a very high value just before the critical temperature is reached, and then falls abruptly to zero.

713. **Distribution of free magnetism.**—Coulomb investigated the distribution of magnetic force by placing a large magnet in a vertical position; he then took a small magnetic needle suspended by a cocoon thread, and fixed at right angles to a stout copper wire so as to retard the oscillations (fig. 687); and having ascertained the number of its oscillations under the influence of the earth's magnetism alone, he presented it to different parts of the magnet. The oscillations were fewer as the needle was nearer the middle of the bar, and when they had reached that position their number was the same as under the influence of the earth's magnetism alone. For magnetised bars of more than 7 inches in length the distribution could always be expressed by a curve whose abscissæ were the distances from the ends of the magnet, and whose ordinates



Fig 687

were the force of magnetism at these points. With magnets of the above dimensions the poles are at the same distance from the end; Coulomb found the distance to be 1.6 inch in a bar 8 inches long. He also found that, with shorter bars, the distance of the poles from the end is $\frac{1}{6}$ of the length; thus with a bar of 3 inches it would be half an inch. These results presuppose that the other dimensions of the bar are very small as compared with its length, that it has a regular shape, and is uniformly magnetised. When these conditions are not fulfilled, the positions of the poles can only be determined by direct trials with a magnetic needle, and even then different results will be found as the magnetic needle is at different distances from the bar to be tested. With lozenge-shaped magnets the poles are nearer the middle. Coulomb found that these lozenge-shaped bars have a greater magnetic moment than rectangular bars of the same weight, thickness, and hardness.

A short magnet is defined by Coulomb as one whose length is less than 50 times its diameter.

Kohlrausch found that the pole of a magnet, as far as its action at a distance is concerned, is $\frac{1}{12}$ of its length from the end.

Jamin investigated the distribution of free magnetism in magnets by suspending from one arm of a delicate balance a small iron ball, and then ascertaining what force, applied at the other arm, was required to detach the ball when placed in contact with various parts of the magnet to be investigated.

714. **Mayer's floating magnets.**—The reciprocal action of magnetic poles may be conveniently illustrated by an elegant method devised by

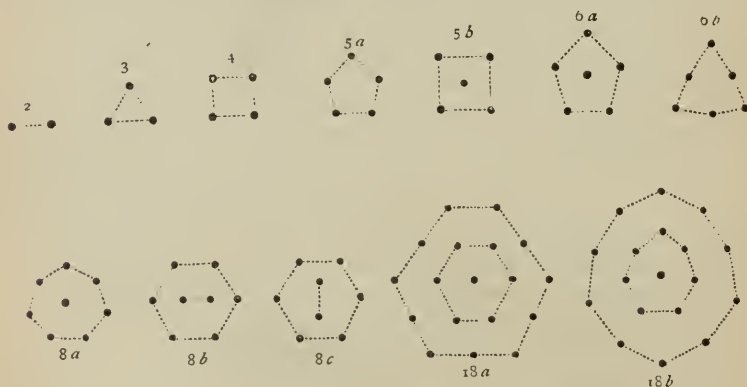

Fig. 688

Professor A. M. Mayer. Steel sewing-needles are magnetised so that their points are north poles, and their eyes, which are thus south poles, just project through minute cork discs, so that when placed in water the magnets float in a vertical position. If the north pole of a strong magnet is brought up near a number of these floating magnets, they are attracted by it, and take up definite positions, forming figures which depend on the reciprocal repulsion of the floating magnets, and on their number. Some of them are repre-

sented in fig. 688. As the number of needles increases, various arrangements are possible which are not equally stable, the letters *a*, *b*, and *c* indicating the decreasing order of stability. A slight shock often causes one form to pass into another and more stable form. Professor J. J. Thomson has made use of these configurations for illustrating his theory of the constitution of a chemical atom.

These figures not only illustrate magnetic actions, but suggest an image of the manner in which alteration of molecular groupings may give rise to physical phenomena, such as those of superfusion (348).

Such floating magnets as are here described are delicate tests of magnetisation, and are convenient for investigating the distribution of the poles in bodies of irregular shape.

715. **Professor Ewing's experiments.**—We may here give an account of Professor Ewing's experiments in illustration of magnetic properties, which explain them without requiring any other assumption than that magnetism is a molecular property, each molecule being a perfect magnet with a north and south pole.

He used a number of small magnets made of steel wire not more than $\frac{1}{10}$ of an inch in diameter and 2 inches long, bent in the middle as shown in fig. 689, so as to bring the centre of gravity below the point of support, which was a small sewing-needle fixed in a lead base, a small depression being punched in the bend. By placing a number of such small magnetic needles near each other, he found that when left to themselves they set in various configurations, each of which is stable, but has no external action. If one part of such a system is disturbed, a new arrangement is established. Each separate magnet takes up a position of stable equilibrium, after oscillations of greater or less amplitude.



Fig. 689

If now any given configuration is submitted to the action of a gradually increasing magnetic field, produced by passing a voltaic current through a series of parallel wires, the magnets are at first deflected progressively, but if the current is stopped these magnets revert to their original arrangement, and there is no permanent effect on the system. This illustrates the case of slight temporary magnetism.

When, however, the strength of the field is further increased, a certain stage is reached at which equilibrium is destroyed, and a fresh configuration is formed in which many of the elementary magnets are in the direction of the field. From this stage any increase in the strength of the field only makes the observation more marked.

On gradually weakening the field, the system does not return through the same stages; it tends towards that configuration in which the magnets are parallel to the field. This illustrates the case of permanent magnetisation.

If the system is quite homogeneous—that is, if the molecular magnets are uniformly arranged—the passage to parallelism is comparatively easy; this represents the case of soft iron. If the system is not homogeneous and the magnets form unequal groups, they do not follow the action

equally and at the same time ; the magnetisation is prolonged, and the remanent magnetism is also more stable. This represents the case of steel.

The action of heat on a magnetic substance may be explained by the supposition that it acts in two ways, by increasing the distance of the molecular magnets from each other, and by setting them in oscillation. The first cause facilitates the action of the field, the second diminishes the magnetic moment : one or the other predominates, according to the strength of the field.

To account for the disappearance of magnetic properties at the critical temperature, it may be assumed that the oscillations gradually increase until they change into a rotatory motion of the molecules.

CHAPTER III

LAWS OF MAGNETIC ACTION

716. **Poles of a magnet.**—We have spoken of the ends of a bar magnet, where its attraction for iron filings appears to be greatest, as the poles of the magnet. But it is necessary to be more precise. All parts of a bar magnet from the neutral plane to one end, say the red end, repel a red pole, the force increasing from the middle to the end. If we imagine an isolated red pole to be situated at a definite distance from the magnet, and draw lines from each point of the red half of the magnet to the pole, and take lengths along these lines to represent the magnitudes of the several forces, we can by ordinary mechanics find the direction of the resultant of these forces. The point in which the line of the resultant cuts the magnetic axis of the bar may be called the red pole of the magnet. Similarly for the blue pole. But it is found that the position of the poles as so defined is not constant; it varies with varying distance of the pole acted upon, being nearer the end of the bar as the point in question approaches. To obviate this uncertainty it is usual to consider the pole acted upon to be at an infinite distance from the magnet. The lines of action of all the component forces are then parallel, and *the centre of these parallel forces is defined as the pole of the magnet.*

The poles of an ordinary bar magnet may be taken as being about $\frac{1}{2}$ of its length from each end. The poles of a long steel rod, whose length is great in comparison with its cross section—for example, one 30 cm. long and 1 mm. in diameter—may be regarded as being at the ends. If such a magnetised wire is dipped into iron filings, the filings form small tufts at the ends only. The *magnetic axis* of a magnet is the straight line which passes through its two poles.

717. **Laws of magnetic force.**—Consider two long thin magnetised steel wires: we may regard their poles as points, situated at their extremities. The two red poles repel each other with a force which varies inversely as the square of the distance between them. This law of repulsion between two similar poles—the same law holds in the case of attraction between two dissimilar poles—was proved experimentally by Coulomb by two methods: (1) that of the torsion balance, (2) that of oscillations.

718. **The torsion balance.**—This apparatus depends on the principle that, when a wire is twisted through a certain angle, the moment of the couple resisting torsion is proportional to the angle through which the wire

has been twisted (89). It consists (fig. 690) of a glass case closed by a glass top, with an aperture *m* near the edge, to allow the introduction of a magnet, A. In another aperture in the centre of the top a glass tube fits, provided at its upper extremity with a torsion head. This consists of two circular pieces: one, *d*, which is fixed, is divided on the edge into 360° , while on the other, *e*, which is movable, there is a mark, *c*, to indicate its rotation. D and E represent the two pieces of the torsion head on a larger scale. On E there are two uprights connected by a horizontal axis, on which is a very fine silver wire supporting a magnetic needle, *ab*. On the side of the case there is a graduated scale, which indicates the angle of the needle *ab*, and hence the torsion of the wire.

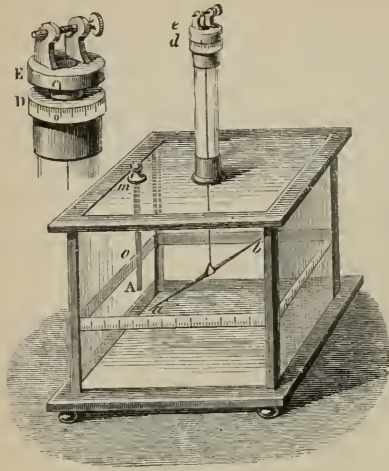

Fig. 690

When the mark *c* of the disc E is at zero of the scale D, the case is so arranged that the wire supporting the needle and the zero of the scale in the case are in the magnetic meridian. The needle is then removed from its stirrup, and replaced by an exactly similar one of copper, or any non-magnetic substance; the tube, and with it the pieces D and E, are then turned so that the needle stops at zero of the graduation. The magnetic needle *ab*, being now replaced, is exactly in the magnetic meridian, and the wire is without torsion.

Before introducing the magnet A, it is necessary to investigate the action of the earth's magnetism on the needle *ab*, when the latter is removed out of the magnetic meridian. This will vary with the magnetic moment of the needle, with the dimensions and nature of the particular wire used for suspension, and with the intensity of the earth's magnetism in the place of observation. Accordingly the piece E is turned until *ab* makes a certain angle with the magnetic meridian. Coulomb found in one of his experiments that E had to be turned 36° in order to move the needle through 1° ; that is, the earth's magnetism was equal to a torsion of the wire corresponding to 35° . As the couple of torsion is proportional to the angle of torsion, when the needle is deflected from the meridian by 2, 3 . . . degrees the directive action of the earth's magnetism is equal to 2, 3 . . . times 35° .

The action of the earth's magnetism having been determined, the magnet A is placed in the case so that similar poles are opposite each other. In one experiment Coulomb found that the pole *a* was repelled through 24° . Now the force which tended to bring the needle into the magnetic meridian was represented by $24^\circ + 24 \times 35^\circ = 864$, of which the part 24° was due to the torsion of the wire, and $24 \times 35^\circ$ was the equivalent in torsion of the directive force of the earth's magnetism. As the needle was in equilibrium, it is clear that the repulsive force which counterbalances these forces must be equal

to 86.4° . The torsion head was then turned until ab made an angle of 12° . To effect this, eight complete turns of the disc, E , were necessary. The total force which now tended to bring the needle into the magnetic meridian was composed of: 1st, the 12° of torsion by which the needle was distant from its starting point; 2nd, of $8 \times 360^\circ = 2880^\circ$, the torsion of the wire; and 3rd, the force of the earth's magnetism, represented by a torsion of $12 \times 35^\circ$. Hence the forces of torsion which balance the repulsive forces exerted at a distance of 24° and of 12° are—

24°	864
12°	3312

Now, 3312 is very nearly four times 864; hence for half the distance the repulsive force is four times as great.

In the above calculation several assumptions are made which are not strictly justifiable. In the first place, the moment of the earth's couple on the magnet ab is proportional not to the deflection but to the sine of the deflection (726). The difference between an angle and its sine may be neglected when the angle does not exceed 5° or 6° , but not for angles so large as 24° . Secondly, the distance between the acting poles has been measured along an arc instead of along a chord of a circle; and thirdly, the action between the poles A and a only has been taken into account, that between A and b being neglected.

719. **Method of oscillations.**—A magnetic needle oscillating under the influence of the earth's magnetism may be considered as a pendulum, and the laws of pendulum motion apply to it (56). The method of oscillations consists in causing a magnetic needle to oscillate first under the influence of the earth's magnetism alone, and then successively under the combined influence of the earth's magnetism and of a magnet placed at unequal distances.

The following determination by Coulomb will illustrate the use of the method. A magnetic needle was used which made 15 oscillations in a minute under the influence of the earth's magnetism alone. A magnetic bar about 2 feet long was then placed vertically in the plane of the magnetic meridian, so that its north pole was downwards and presented

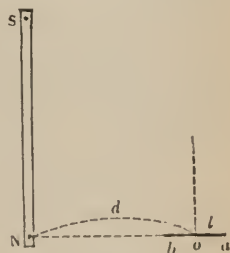

Fig. 691

to the south pole b of the oscillating needle (fig. 691), so as to concur in its action with that of the earth. He found that at a distance of 4 inches the needle made 41 oscillations in a minute, and at a distance of 8 inches 24 oscillations. Now, from the laws of the pendulum, the intensities of the forces are inversely as the squares of the times of oscillation. Hence, if we call H the horizontal force of the earth's magnetism, F_1 the force due to the magnet at the distance of 4 inches, F_2 at the distance of 8 inches, we have

$$H : H + F_1 = 15^2 : 41^2, \text{ and}$$

$$H : H + F_2 = 15^2 : 24^2;$$

eliminating H ,

$$F_1 : F_2 = 41^2 - 15^2 : 24^2 - 15^2 = 1456 : 351 = 4 : 1 \text{ nearly,}$$

or $F_1 : F_2 = 4 : 1.$

In other words, the force acting at 4 inches is quadruple that which acts at double the distance.

It will be observed that the influence of the upper pole S in modifying the field at o has been neglected, and therefore we can only expect the results to agree approximately with the inverse square law; this law, indeed, cannot be said to be strictly proved by either of the experimental methods employed by Coulomb. A more satisfactory proof will be given later (725).

The attraction or repulsion between two poles at a given distance apart depends on the product of the strengths of the two poles; for, clearly, if either pole is doubled or trebled, the force in action would be twice or thrice as great as before, but if one were doubled while the other was trebled, the force would be increased sixfold.

Thus, finally, the force of repulsion, F , between two similar poles, of strengths m_1, m_2 , whose distance apart is r , varies as $\frac{m_1 m_2}{r^2}$, or we may write $F = \frac{m_1 m_2}{r^2}$, if the units are properly chosen.

Suppose the force to be measured in dynes (63), r in centimetres, and that the poles are equal in strength, and each equal to m ; then

$$F \text{ (dynes)} = \frac{m^2}{r^2}.$$

Let $r = 1$ cm., and let the value of m be increased or diminished until F is exactly equal to 1 dyne: then $1 = \frac{m^2}{1}$, or $m = 1$; that is, the pole is of unit strength.

720. Unit pole. Magnetic moment.—We thus have a definition of *unit pole*; it is a pole of such strength that it would repel another pole exactly like itself with the force of 1 dyne if they were 1 centimetre apart. A pole of strength m would repel unit pole at unit distance with a force of m dynes.

The *moment* of a magnet is the product of the strength of either pole into the distance between them. If M is the moment, m the strength of each pole, and l their distance apart,

$$M = ml.$$

As a rule we cannot determine either l or m , but their product is a readily measured magnitude.

The *magnetic intensity* at any point in a magnetic field is equal to the force (in dynes) on unit pole.

We can picture mentally an isolated pole by thinking of one end of a magnetised steel wire, the other end of which is too remote to be considered. Lines of force radiate from an isolated pole (say of strength m) equally in all directions, the intensity of the resulting magnetic field, at any distance r from the pole, being $\frac{m}{r^2}$. But the *magnetic intensity* at a point of a magnetic

field is also defined as the number of lines which pass through the unit of area (1 sq. cm.) at the point held at right angles to the field. By comparing these two modes of expressing the intensity of a magnetic field, we arrive at an expression for the number of lines of force which radiate from a magnetic

pole. For suppose an isolated pole, m , to be the centre of a sphere of radius r (cm.), and N to represent the total number of radiating lines. Since the surface of the sphere is $4\pi r^2$ (sq. cm.) and the lines are uniformly distributed, the number per square centimetre, or intensity of magnetic field at distance $r = \frac{N}{4\pi r^2}$; but this is equal to $\frac{m}{r^2}$; $\therefore N = 4\pi m$. Thus there are $4\pi (= 12.6)$ lines of force proceeding from each unit magnetic pole.

721. **Magnetic permeability.**—When various substances, such as glass, wood, cardboard, or copper, are brought into the magnetic field, the lines of force proceed through them as if there were air in their place. But if a bar of soft iron is brought into the field the lines of force pass through it in larger quantities, the distribution of the field is thereby altered, and within a certain range the other lines are deflected. The iron attracts them as it were, causing those lines in the neighbourhood to make their way through it; the iron is more *permeable* to lines of magnetic force.

This may be illustrated by considering the case of a stream of water with a steady flow, in which is a quantity of river weed, which offers resistance to the flow; if the weed is removed from a certain space in the middle, the resistance which it offers is also removed, the water flows more easily there, and the direction of the lines of flow in the neighbouring parts is now deflected towards the free part.

The lines of force thus falling on a piece of soft iron converge towards the iron and emerge at the other end. Where the lines enter is a south and where they emerge a north pole. A magnetic needle free to move and brought near the magnet takes up such a position that the lines of force have undisturbed course through it. With soft iron this is also the case; the molecular magnets are rotated, so that they offer as little hindrance as possible.

If a soft iron ring is placed in a magnetic field, its plane being parallel to the field, the lines of force make their way through the iron and very few enter the interior, as may be seen by means of iron filings. A massive iron cylinder acts thus as a *magnetic screen*, shielding magnets placed in the interior against the action of the magnetic field.

The *magnetic permeability* of a substance is defined as the ratio of the number of lines of force passing through a mass of it to the number which would pass through the same volume of air or other non-magnetic material, the magnetising force being the same in each case. It is denoted by the symbol μ .

If H represents the strength of a magnetic field, that is, the number of lines per square centimetre of cross section, and B represents the number of lines per square centimetre passing through a mass of iron placed in the field, $B/H = \mu =$ the magnetic permeability. B is called the *magnetic induction*, or *flux-density*.

The permeability of iron is not a constant quantity, but depends upon the quality of the iron, the way in which it has been treated, and the strength of the field. For soft iron the permeability may be as high as 3000, and for steel in a strong field as low as 2. The permeability of air and other non-magnetic materials is approximately unity, while bismuth—a diamagnetic substance—has a permeability less than unity, viz. .99982. An alloy of iron

and aluminium containing $2\frac{1}{4}$ per cent. of aluminium has, according to Barrett, a higher permeability than the best charcoal iron.

722. **Magnetic susceptibility.**—In considering the permeability of a substance our attention is drawn to the facility with which lines of force pass through it ; but there is another aspect in which we may regard the effect of the field on the magnetic substance. A piece of iron in the magnetic field becomes a magnet, with a south pole at the end where the lines enter, and a north pole at the end where they emerge, and has a definite magnetic moment. The magnetic moment acquired per unit volume is called the *intensity of magnetisation*, and is denoted by I . If M is the magnetic moment, and V the volume of the iron in cubic centimetres, $I = \frac{M}{V}$.

If the iron is in the form of a rod of length l and cross section A , and if we suppose the poles to be situated at its ends and to have each a strength m , then $M = ml$, and $V = lA$, or $I = \frac{m}{A}$, from which it is seen that the intensity of magnetisation is equal to the pole strength of the specimen per unit of cross section.

It is clear that the intensity of magnetisation of a magnetic substance in a magnetic field depends upon two things, viz. the nature and condition of the substance and the strength of the field. So we may write $I = \kappa H$, where H is the field, and κ a coefficient depending on the material, and called the *magnetic susceptibility* of the substance.

The relation between μ and κ , the coefficients of permeability and susceptibility, may be readily found as follows :—The pole strength m per square centimetre of a rod in a magnetic field H is I , as was proved above, and therefore the number of lines of force proceeding from it is $4\pi I$ (720). Hence the total number of lines, due to the field and to the induced magnetism, is $H + 4\pi I$, but this is equal to B . Hence

$$B = H + 4\pi I ;$$

but by definition $B = \mu H$ and $I = \kappa H$,

$$\therefore \mu = 1 + 4\pi\kappa.$$

For hard steel in a strong field, for which $\mu = 2$, $\kappa = \frac{1}{12.5}$ approximately = .08 ; for soft steel at low magnetising force, where μ may be 2000, $\kappa = \frac{1999}{12.5} = 160$.

723. **Magnetic force at a point in a magnetic field due to a short bar magnet.**—We shall consider two cases : (1) when the point is on the axis

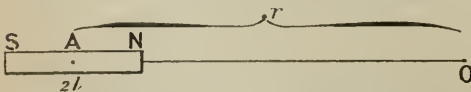

Fig. 692

produced of the magnet, (2) when it is on the line drawn perpendicular to the magnet through its middle point. In each case it is assumed that the magnet

is small compared with the distance of the point from it.

(1) 'End on' position (fig. 692).—Let SN be the magnet, A its middle point, m the strength of each of its poles, and $2l$ the distance between them

so that its moment = $M = 2lm$. Let there be a red pole of strength m' at O , and let $AO = r$. The force between N and O is $\frac{mm'}{(r-l)^2}$, that between S and O is $\frac{-mm'}{(r+l)^2}$. Hence, the force on pole m' at O due to the magnet SN

$$= F = \frac{mm'}{(r-l)^2} - \frac{mm'}{(r+l)^2} = mm' \frac{4rl}{(r^2-l^2)^2} = \frac{2m'Mr}{(r^2-l^2)^2}$$

The direction of the force is along NO .

If l^2 is negligible in comparison with r^2 , $F = \frac{2m'M}{r^3}$, or the force on unit pole (*i.e.* the strength or intensity of the field) at O is $\frac{2M}{r^3}$. With

regard to the suppression of l^2 above, let us take the case in which $2l = 8$ cm. and $r = 40$ cm., then

$r^2 = 1600$ and $l^2 = 16$; hence in neglecting l^2 we are making an error of 1 per cent. If we desire greater accuracy the complete formula must be used.

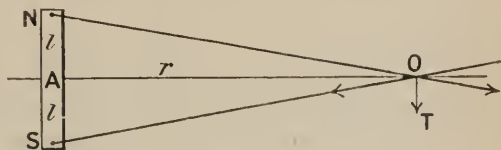

Fig. 693

(2) 'Broadside on' position (fig. 693).—

The force between N and $O = \frac{mm'}{r^2+l^2}$ along NO

„ „ S „ $O = \frac{mm'}{r^2+l^2}$ „ OS .

These have a resultant along OT , whose magnitude F'

$$= \frac{2mm'}{r^2+l^2} \cdot \cos \text{TOS} = \frac{2mm'}{r^2+l^2} \cdot \frac{l}{(r^2+l^2)^{\frac{1}{2}}} = \frac{m'M}{(r^2+l^2)^{\frac{3}{2}}} = \frac{m'M}{r^3}$$

if we neglect l^2 .

Hence the strength of the magnetic field at O is $\frac{M}{r^3}$, and its direction is parallel to the length of the magnet.

Thus the field due to a bar magnet varies inversely as the cube of the distance from the centre of the magnet, and, for a given distance, is twice as great along the axis as at right angles to it.

724. Comparison of moments of magnets.—

Let M, M_1 represent the moments of the magnets to be compared, H the earth's field, and let the magnet M be placed in the *end on* position with regard to the magnetic needle AB , length l , the strength of each of whose poles is m . The needle is then subjected to two magnetic fields, H due to the earth, and F ($= \frac{2M}{r^3}$) due to the magnet, and

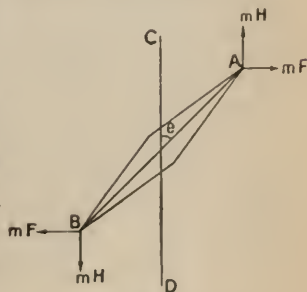

Fig. 694

will be deflected from the meridian by an angle θ . The couple due to

H is $Hm \times l \sin \theta$; that due to F is $Fm \times l \cos \theta = \frac{2M}{r^3} \cdot ml \cos \theta$; since the needle is in equilibrium these couples are equal,

$$\begin{aligned} \therefore F &= H \tan \theta \\ \text{or, } \frac{M}{H} &= \frac{1}{2} r^3 \tan \theta. \end{aligned} \quad (1)$$

Let the second magnet, of moment M_1 , be similarly placed at such a distance r_1 as to produce the same deflection; then

$$\begin{aligned} \frac{M_1}{H} &= \frac{1}{2} r_1^3 \tan \theta, \\ \therefore M/M_1 &= r^3/r_1^3. \end{aligned}$$

If the magnets are placed in the *broadside on* position the formula (1) becomes

$$\frac{M}{H} = r^3 \tan \theta.$$

Or, we may compare the moments of the two magnets by placing them *at the same time* in the *end on* position with regard to a compass needle, one on each side, at such distances that the needle undergoes no deflection. It is then only necessary to measure the distances (r, r_1) of the centres of the magnets from the centre of the needle, and $M/M_1 = r^3/r_1^3$. It is assumed that the lengths of the magnets to be compared are sufficiently small for l^2 to be neglected in comparison with r^2 .

The moments of two magnets may also be compared by means of the torsion balance (718) as follows:—Suspend the first magnet (M) in the balance so that there is no twist in the wire, and turn the torsion head E (fig. 690) through such an angle a that the needle is deflected θ from the meridian; the torsion in the wire is then $a - \theta$. The couple due to the earth's magnetism tending to turn the magnet into the meridian is $MH \sin \theta$; the torsional couple tending to twist the wire in the opposite direction is proportional to the angle of torsion, and may be written $k(a - \theta)$, where k is a constant. These two couples are equal; therefore $MH \sin \theta = k(a - \theta)$. Now replace the magnet M by M_1 , and let a_1 be the angle through which the torsion head must be twisted to cause the same deflection (θ) as before. Then $M_1 H \sin \theta = k(a_1 - \theta)$; hence $M/M_1 = (a - \theta)/(a_1 - \theta)$. Or, the two magnets may be suspended when connected rigidly together with the centre and axis of one over the centre and axis of the other, and with poles first acting together and then opposed. It will be seen later (736) how the moment of a magnet may be determined in absolute measure.

725. **Gauss's proof of the inverse square law.**—In determining the magnetic force due to a bar magnet, we have assumed that the force between two magnetic poles varies inversely as the square of the distance between them. Suppose we make no such assumption, but write force = $\frac{mm}{r^n}$, where n may be any whole or fractional number; if we then calculate the forces due to the magnet in the 'end on' and 'broadside on' positions successively, we shall, as in 723, find for

F (end on) the value $\frac{nM}{r^{n+1}}$

and for F_1 (broadside on) „ „ $\frac{M}{r^{n+1}}$

thus the force in the 'end on' position is proved to be n times that in the 'broadside on' position.

Introducing these values into the formulæ of the last article, we obtain : -

$$\text{'end on' position of magnet} \quad \frac{M}{H} = \frac{r^{n+1}}{n} \cdot \tan \theta$$

$$\text{'broadside on' position of magnet} \quad \frac{M}{H} = r^{n+1} \tan \theta_1$$

$$\therefore \frac{\tan \theta}{\tan \theta_1} = n.$$

When the experiment is made, it is found that $\tan \theta$ is exactly twice $\tan \theta_1$; hence $n = 2$, and the law of force between two magnetic poles is that of the inverse *square* of the distance. This method of experimental proof admits of much greater accuracy than that of the torsion balance (718).

CHAPTER IV

TERRESTRIAL MAGNETISM

726. **Directive action of the earth on magnets.**—When a magnetic needle is suspended by a thread, as represented in fig. 675, or is placed on a pivot on which it can oscillate freely (fig. 695), it ultimately sets in a position which is more or less north and south. If removed from this position it always returns to it after making a certain number of oscillations.

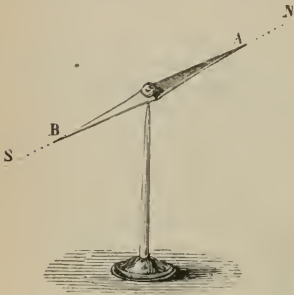

Fig. 695

Analogous observations have been made in different parts of the globe, and from these it has been concluded that the earth itself is a magnet, whose poles are very near the terrestrial poles, and whose neutral line virtually coincides with the equator.

Suppose that the needle, instead of being constrained by the mode of its suspension to move only in a horizontal plane, is free to move in any direction, it will be found to take an inclined position, its red end dipping downwards and its axis making an angle of about 67° with the horizon. The earth being a magnet is surrounded, like any other magnet, by its own field of magnetic force. The lines of force proceed from the red pole, which is near the terrestrial south pole, and sweeping round reach the earth again at the blue pole in the neighbourhood of the north terrestrial pole.

But, as in the case of a bar magnet the lines of force do not leave and enter the bar exclusively at the ends, but to a diminishing extent from the ends to the middle; so with the earth. A magnetic needle freely suspended in a magnetic field always places itself along or parallel to the lines of force in the field, and therefore we may conclude that the lines of force due to the earth's magnetism are, in England, inclined to the horizontal plane at an angle of about 67° , and are inclined *downwards*, since it is the red end of the needle which dips. In fig. 696 let ab be the direction in which a compass needle lies, and ac the direction which the needle takes when it is free to move in the plane

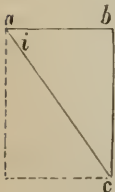

Fig. 696

of the magnetic meridian; then, if ac represent not only the direction but the magnitude of the earth's field, it is clear, from the parallelogram of forces, that ab will represent the horizontal component, and bc the vertical component, of the field.

If the experiment described above is made at different parts of a room, it will be found that the *direction* of the needle is the same in all cases; hence the lines of the earth's force are at the same place parallel to each other, and the field is a uniform field. Imagine a room filled with wires or threads, all stretched straight and parallel to the axis of a freely suspended magnetic needle and uniformly distributed, so that there are exactly as many, per unit of area at right angles to them, at one part as at another; such an arrangement would represent the local field of the earth's magnetism. And as we may resolve a force represented by ac (fig. 696) into a horizontal force ab and a vertical force bc , so we may consider the earth's magnetic field, represented by uniformly distributed lines parallel to ac , as being equivalent to two fields, one horizontal with uniformly distributed lines parallel to ab , the other vertical with uniformly distributed lines parallel to bc .

In most cases we have to deal only with compass needles and the horizontal field. That it is a uniform field is shown by placing a magnet horizontally on a cork floating in water: the magnet will at first oscillate, and then gradually settle in the magnetic meridian, and will not (provided that no iron is in the neighbourhood) show any tendency to move either towards the north or towards the south. The couple acting on a needle deflected through an angle θ from the meridian is $MH \sin \theta$, which is often referred to as the *terrestrial magnetic couple*. It represents the twisting effect on the needle when it is inclined to the meridian; its maximum value is MH , when the needle is at right angles to the meridian.

If the horizontal field were not uniform, the forces acting at A and B (fig. 695) would not be equal and parallel, and consequently would have a resultant causing the needle to move in a definite direction. But no such motion can be detected; hence the field is uniform.

727. Magnetic elements. Declination.—In order to specify completely the magnetic state at any point of the earth's surface, three things must be known; these are—i. Declination; ii. Inclination or Dip; iii. Force or Intensity. These three are termed the *magnetic elements* of the place. We shall explain them in the order in which they stand.

The *geographical meridian* of a place is the imaginary plane passing through this place and through the two terrestrial poles, and the *meridian* is the outline of this plane upon the surface of the globe. Similarly the *magnetic meridian* of a place is the vertical plane passing at this place through the two poles of a compass needle in equilibrium.

In general the magnetic meridian does not coincide with the geographical meridian, and the angle which the magnetic makes with the geographical meridian—that is to say, the angle which the direction of the needle makes with the geographical meridian—is called the *declination* or *variation of the magnetic needle*. The declination is said to be *east* or *west*, according as the north pole of the needle is to the east or west of the geographical meridian.

728. Variations in declination.—The declination of the magnetic needle, which varies in different places, is at present west in Europe and in Africa, but east in Asia and in the greater part of North and South America. It shows further considerable variations even in the same place. These variations are of two kinds: some are regular, and are either secular, annual, or

diurnal ; others, which are irregular, are due to what are called *magnetic storms* (738).

Secular variations.—In the same place the declination varies in the course of time and the needle appears to make oscillations to the east and west of the meridian, the duration of which extends over centuries. The declination has been known at London since 1580, and the following table represents the variations which it has undergone :—

Year	Declination	Year	Declination
1580	11° 17' E.	1815	24° 27' W.
1634	4° 5'	1820	24° 11'
1657	0°	1831	24° 0'
1672	2° 30' W.	1865	20° 34'
1700	9° 40'	1871	19° 42'
1720	13° 0'	1880	18° 33'
1760	19° 30'	1883	18° 15'
1790	23° 39'	1896	16° 56'
1800	24° 36'	1901	16° 24'
1806	24° 28'	1904	16° 15'

This table shows that since 1580 the declination has varied at London as much as 36°, and that the greatest westerly declination was attained in 1800, since which time the north end of the needle has gradually tended towards the east.

At Paris the changes have been similar to those at London. In 1580 the needle showed an easterly declination of 11° 30'; in 1666 it was at zero; from that time it gradually tended towards the west, and reached its maximum declination of 22° 34' in 1814; since then it has steadily diminished, and is now (1905) 14° 20', the decrease at present being a little more than 5' per year.

At Yarmouth and Dover the variation is about 40' less than at London; at Hull and Southampton about 20' greater; at Newcastle and Swansea about 1° 45', and at Liverpool 2° 0', at Edinburgh 3° 0', and at Glasgow and Dublin about 3° 50' greater than at London.

The following are the observations of the magnetic elements at Kew extending over thirty-nine years :—

Year	Declination	Inclination	Horizontal force
1865	20° 59'	68° 7'	0·1765
1875	19° 41'	67° 48'	0·1791
1880	18° 59'	67° 42'	0·1797
1885	18° 26'	67° 38'	0·1806
1890	17° 51'	67° 33'	0·1817
1895	17° 17'	67° 24'	0·1828
1898	17° 1'	67° 17'	0·1836
1900	16° 53'	67° 11'	0·1843
1901	16° 48'	67° 9'	0·1846
1904	16° 37'	67° 1'	0·1854

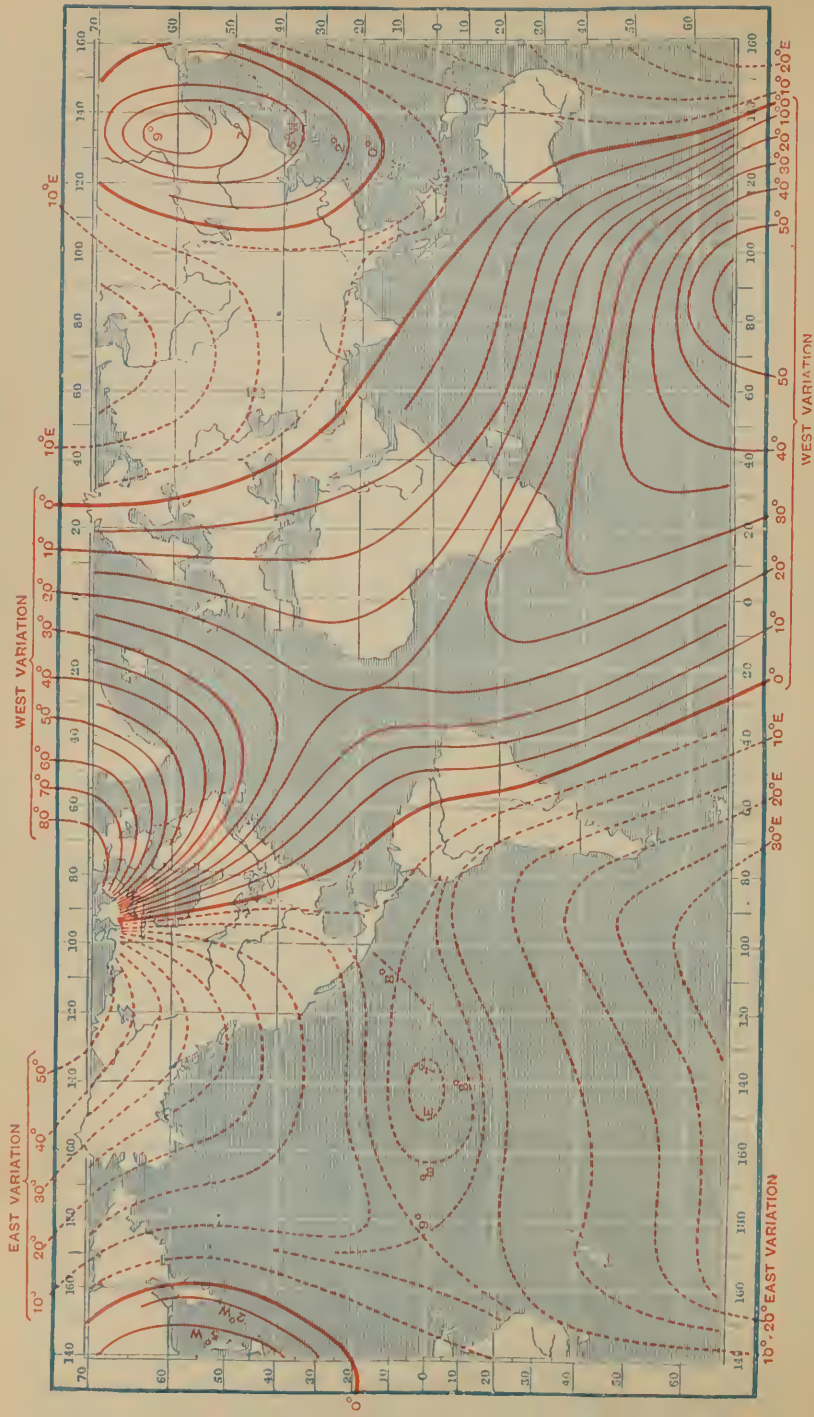

In certain parts of the earth the magnetic coincides with the geographical meridian. These points are connected by an irregularly curved imaginary line, called a *line of no variation* or *agonic line*. Such a line cuts the east of South America, and, passing east of the West Indies, enters North America near Cape Hatteras, and traverses Hudson's Bay; thence it passes through the Arctic regions, entering the Old World east of the White Sea, traverses the Caspian, cuts the east of Arabia, turns then towards Australia, and passes across the Antarctic circle, to complete the circuit.

Isogonic lines are lines connecting those places on the earth's surface at which the declination is the same.

Maps on which such isogonic lines are depicted are called *declination* or *variation maps*; and a comparison of these in various years is well fitted to show the variation which this magnetic element undergoes. The first of the kind were constructed in 1700 by Halley. Plate IV. represents a map on Mercator's projection giving these lines for the year 1900. It will be seen that the surface of the globe is divided by these lines into two regions: one, the smaller, in which the variation is westerly, as indicated by the continuous lines; the other, in which the variation is easterly, as indicated by the dotted lines. There is also a closed agonic line in the East of Asia, enclosing Japan and a portion of China. Within this curve the declination is westerly. This chart is useful to the mariner as not only giving him the declination in any place, but also as showing him the places on the globe where the declination changes most rapidly. Of these the most remarkable are the coast of Newfoundland, the Gulf of St. Lawrence, the seaboard of North America, and the English Channel and its approaches.

729. **Annual and diurnal variations.**—Cassini first discovered in 1780 that the declination is subject to small annual variations. At Paris and London it is greatest about the vernal equinox, diminishes from that time to the summer solstice, and increases again during the nine following months. It does not exceed from 15' to 18', and it varies somewhat at different epochs.

The *daily variations* were first discovered by Graham in 1722. In this country the north pole moves every day from east to west from sunrise until one or two o'clock; it then tends towards the east, and at about ten o'clock regains its original position. During the night the needle is almost stationary. Thus the westerly declination is greatest during the warmest part of the day.

The amount of the daily variation depends on the season of the year, ranging from 25' in summer to 5' or less in winter. The mean annual value of the daily range varies from year to year, oscillating between maximum values which occur every ten and a half or eleven years. Years of maximum mean daily variation coincide with years of maximum sunspot area (738). The amplitude of the daily variation decreases from the poles towards the equator, where it is very slight. Near the equator a line may be drawn, passing through places where there is no daily variation.

730. **Declination compass.**—The *declination compass* is an instrument by which the magnetic declination of any place may be determined when its astronomical meridian is known. The form represented in fig. 697 consists of a brass box, AB, in the bottom of which is a graduated circle, M.

In the centre is a pivot on which oscillates a very light lozenge-shaped magnetic needle, *ab*. To the box are attached two uprights supporting a horizontal axis, *X*, on which is fixed an astronomical telescope, *L*, movable in a vertical plane. The box rests

on a foot, *P*, about which it can turn in a horizontal plane, taking with it the telescope. A fixed circle, *QR*, which is called the *azimuth circle*, measures the number of degrees through which the telescope has been turned, by means of a vernier, *V*, fixed to the box. The inclination of the telescope, in reference to the horizon, may be measured by another vernier, *K*, which moves with the axis of the telescope, and is read off on a fixed graduated arc, *x*.

The first thing in determining the declination is to adjust the compass horizontally by means of the screws *SS*, and the level *n*. The astronomical meridian is then found, either by an observation of the sun at noon exactly, or by any of the ready methods known to astronomers. The box *AB* is then turned until

the telescope is in the plane of the astronomical meridian. The angle made by the magnetic needle with the diameter *N*, which corresponds with the zero of the scale, and is exactly in the plane of the telescope, is then read off on the graduated limb, and this is east or west, according as the pole *a* of the needle stops at the east or west of the diameter *N*.

731. Correction of errors.—These indications of the compass are only correct when the magnetic axis of the needle—that is, the right line passing through the two poles—coincides with its axis of figure, or the line connecting its two ends. This is not usually the case, and a correction must therefore be made, which is done by the *method of reversion*. For this purpose the needle is not fixed in the cap, but merely rests on it, so that it can be removed and its position reversed; thus what was before the lower is now the upper face. The mean between the observations made in the two cases gives the true declination.

For, let *NS* be the astronomical meridian, *ab* the axis of figure of the needle, and *mn* its magnetic axis (fig. 698). The true declination is not the arc *Na*, but the arc *Nm*, which is greater. If now the needle is turned, the line *mn* makes the same angle with the meridian *NS*; but the north end of

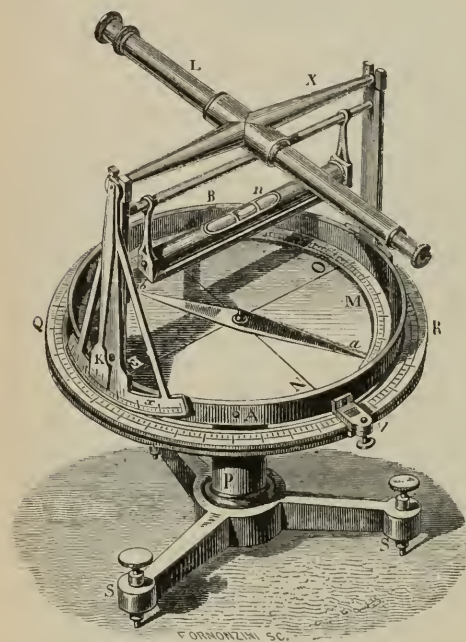

Fig. 697

the needle, which was on the right of *mn*, is now on the left (fig. 699), so that the declination, which was previously too small by a certain amount, is now too large by the same amount. Hence, provided the error be small, the true declination is given by the mean of these two observations.

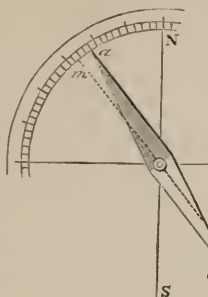

Fig. 698

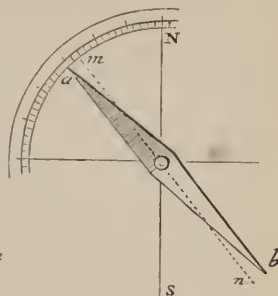

Fig. 699

732. **Mariner's compass.**—The magnetic action of the earth has received its most important application in the *mariner's compass*. This is a declination compass used in guiding the course of a ship. Fig. 700 represents a view of the whole, and fig. 701 a vertical section. It consists of a cylindrical case, *BB'*, which is supported on *gimbals* so as to keep the compass in a horizontal position in spite of the rolling of the vessel. These are two concentric

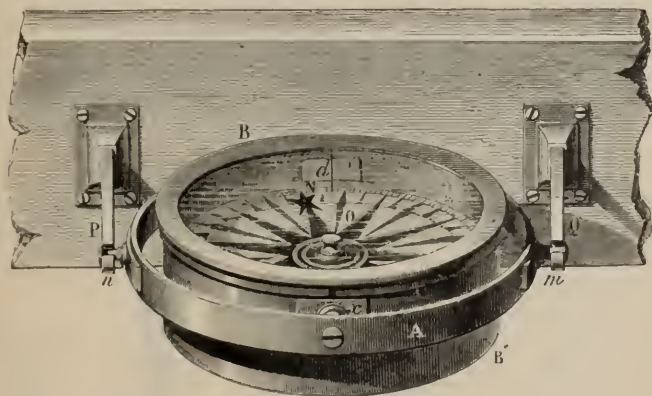

Fig. 700

rings, one of which, attached to the case itself, moves about the axis *xx'* which plays in the outer ring *AB*, and this moves in the supports *PQ*, about the axis *mn*, at right angles to the first.

In the bottom of the box is a pivot, on which is placed, by means of an agate cap, a magnetic bar, *ab*, which is the needle of the compass. On this is fixed a disc of mica, called the compass card, a little larger than the length of the needle, on which is traced a star or *rose*, with thirty two branches, making the eight points or *rhumbs* of the wind, the demi-rhumbs, and the quarters. The branch ending in a small star, and called *N*, corresponds to the magnetic axis of the bar *ab*, which is underneath the disc.

There are several objections to the compass just described, of which one

is that the magnet *ab* must be pierced at the centre for fitting the agate cap, and that its magnetic character is thereby altered. Another objection is the uncertainty as to the direction of the magnetic axis of the magnet. Errors from these causes may be avoided by using *two* magnets instead of one. They are rectangular in form, and are attached at right angles to the card, parallel to each other, and equidistant from the centre.

The box or bowl in which the compass card is supported is made of copper, to produce electrodynamic damping of the needle or needles (963).

In Lord Kelvin's compass, the card and its attachments are made as light as possible, to diminish the friction at the pivot and so render the compass more sensitive. The *card* consists of a thin aluminium circular rim with silk strings extending radially from it to a small aluminium disc at the centre, to which is fitted an agate or sapphire cap. A thin paper annulus is gummed to the strings, and on this are marked the points of the compass. The pivot on which the cap rests is made of platinum-iridium, to ensure hardness and freedom from oxidation. There are eight magnets, of the thickness of a knitting-needle, and of lengths ranging from 8 cm. to 5 cm., placed symmetrically on each side of the centre and connected together by silk strings; they are supported from the aluminium ring by silk strings, and lie in a plane about 3 cm. below the card.

The weight of card magnets and all, is not more than 180 grains, or $11\frac{1}{2}$ grammes. Since the needles are some way below the point of suspension the card remains horizontal even when the earth's vertical force (*i.e.* the tendency of the needles to dip) is considerable. The period of vibration of the card is greater than in the older form of compass card; but, owing to the comparative absence of friction, the needles always point in the direction of the horizontal field.

The bowl of Lord Kelvin's compass has a compartment at its base partially filled with a viscous liquid (*e.g.* castor oil), to prevent oscillations.

The *prismatic compass* is greatly used for surveying, more especially for military purposes; it differs from the mariner's compass mainly in its dimensions, and in the way in which observations are made. It consists of a shallow metal box about $2\frac{1}{2}$ inches in diameter (fig. 702); the needle, which is fixed below the compass card, plays on a pivot much as in



Fig. 701

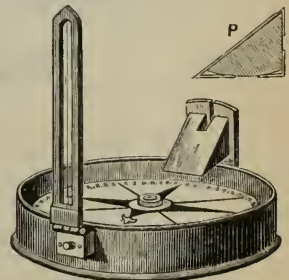

Fig. 702

fig. 701. On the left of fig. 702 is seen a metal frame across which is stretched a horse-hair, forming a sight-vane. Exactly opposite this is a right-angled prism *P* enclosed in a metal case, with an eyehole and a slit as represented at the side of the figure.

When an observation is to be made, the compass is held horizontally, and



LINES OF EQUAL MAGNETIC DIP, 1900.

No. V.

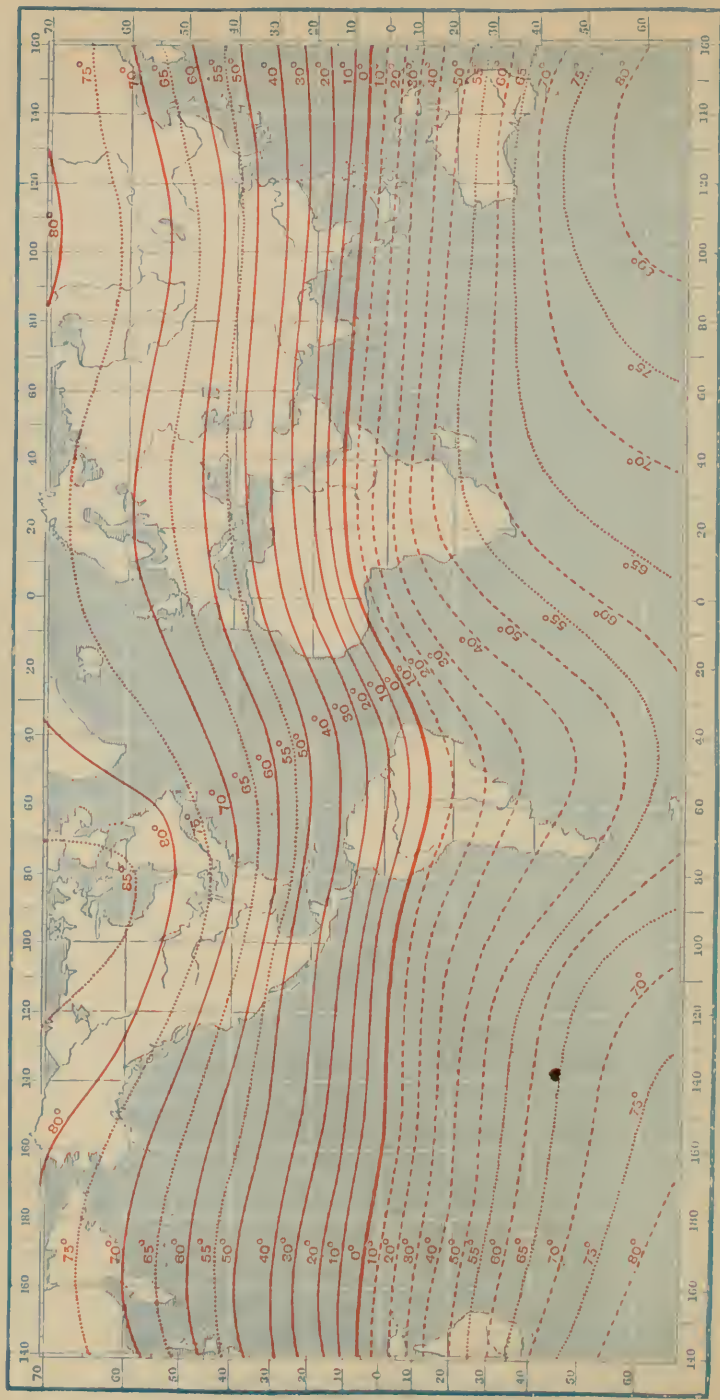

so that the slit in the prism, the hair of the sight-vane, and the distant object are seen to be in the same line; the observer, looking through the eyehole, notes the angle which the needle makes; a similar observation is made with another object, and thus the angle between them, or their *bearing*, is given.

The sight-vane moves on a hinge, and can be turned down, when it presses a spring which lifts the magnet from the pivot and keeps it rigid, so that the compass can be transported in any position.

As the image is seen through the convex face of the prism it is magnified, and as it is seen by reflection it is reversed, hence in order that the figures may be read correctly they must be reversed on the card; the reflection being total there is little loss of light.

733. Inclination or dip. Magnetic equator.—If the needle is so arranged that it can move freely in a vertical plane about a horizontal axis, it will be seen that, although the centre of gravity of the needle lies in the axis of suspension, the north pole in our hemisphere dips downwards. In the southern hemisphere the south pole is inclined downwards.

The angle which the magnetic needle makes with the horizon, when the vertical plane in which it moves coincides with the magnetic meridian, is called the *inclination* or *dip* of the needle. In any other plane than the magnetic meridian the inclination *increases*, and is 90° in a plane at right angles to the magnetic meridian. For the magnetic inclination represents the direction of the total magnetic force, which may be resolved into two forces, one acting horizontally and the other vertically. When the needle can only move in a plane at right angles to the magnetic meridian, the horizontal component can only act in the direction of the axis of suspension, and therefore cannot affect the needle, which is then solely influenced by the vertical component, and consequently stands vertical.

The value of the dip, like that of the declination, differs in different localities. It is greatest in the polar regions, and decreases with the latitude to the equator, where it is approximately zero. In London at the present time (1905) the dip is $66^\circ 56'$. In the southern hemisphere the inclination is again seen, but in a contrary direction; that is, the south pole of a needle dips below the horizontal line.

The *magnetic poles* of the earth are those places in which the dipping-needle stands vertical, that is, where the dip is 90° . In 1831 the first of these, the magnetic north pole, was found by Sir James Ross in $96^\circ 43'$ west longitude and 70° north latitude. The same observer found in the South Sea, in 76° south latitude and 168° east longitude, that the inclination was $88^\circ 37'$. From this and other observations, it has been calculated that the position of the magnetic south pole was at that time in about 154° east longitude and $75\frac{1}{2}^\circ$ south latitude. The line of no declination (agonic line) passes through these poles, and the lines of equal declination (isogonic lines) converge towards them.

The *magnetic equator*, or *aclinic line*, is the line which joins all those places on the earth where there is no dip: that is, all those in which the dipping-needle is horizontal. It is a somewhat sinuous line, not differing much from a great circle inclined to the equator at an angle of 12° , and cutting it on two points nearly opposite each other—one in the Atlantic and

one in the Pacific (see Plate V.). These points appear to be gradually moving their position, and travelling from east to west.

Lines connecting places in which the dip is the same are called *isoclinic lines*. They have a certain analogy and parallelism with the parallels of latitude, and the term *magnetic latitude* is sometimes used to denote positions on the earth with reference to the magnetic equator. Plate V. is an inclination map for the year 1900, the construction of which is quite analogous to that of the map of declination.

The inclination is subject to secular variations, like the declination, as is readily seen from a comparison of maps of inclination for different epochs. At Paris, in 1671, the inclination was 75° ; since then it has been continually decreasing: in 1835 it was $67^\circ 24'$; in 1849, 67° ; in 1859, $66^\circ 16'$; in 1869, $65^\circ 43'$; in 1879, $65^\circ 32'$; in 1883, $65^\circ 17'$; in 1891, $65^\circ 11'$; in 1893, $65^\circ 8'$; in 1895, $65^\circ 5'$; in 1896, $65^\circ 2'$; in 1897, $65^\circ 1'$; and in 1901, $64^\circ 54'$.

The following table gives the secular changes in the inclination at London, from which it will be seen that since 1723, in which it was at its maximum, it has continually diminished by an average of something more than three minutes in each year:—

Year	Inclination	Year	Inclination
1576	$71^\circ 50'$	1854	$68^\circ 31'$
1600	72°	1859	$68^\circ 21'$
1676	$73^\circ 30'$	1874	$67^\circ 43'$
1723	$74^\circ 42'$	1876	$67^\circ 39'$
1773	$72^\circ 19'$	1878	$67^\circ 36'$
1780	$72^\circ 8'$	1880	$67^\circ 35'$
1790	$71^\circ 33'$	1883	$67^\circ 31'$
1800	$70^\circ 35'$	1896	$67^\circ 10'$
1821	$70^\circ 31'$	1901	$67^\circ 7'$
1828	$69^\circ 47'$	1904	$66^\circ 57'$
1838	$69^\circ 17'$		

734. **Inclination compass.**—An *inclination compass*, or *dip circle*, is an instrument for measuring the magnetic inclination or dip. One form, represented in fig. 703, though not best adapted for the most accurate measurements, is well suited for illustrating the principle. It consists of a graduated horizontal brass circle *m*, supported on three legs, provided with levelling screws. Above this circle there is a plate A, movable about a vertical axis, and supporting, by means of two columns, a second graduated circle M, which measures the inclination. The axle of the needle rests on agate plates on a frame *r*.

To observe the inclination, we must first determine the magnetic meridian, which is effected by turning the plate A on the circle *m* until the needle is vertical, for in that case it is in a plane at right angles to the magnetic meridian (733). The plate A is then turned 90° on the circle *m*, by which the vertical circle M is brought into the magnetic meridian. The angle *dca*, which the magnetic needle makes with the horizontal diameter, is the angle of inclination.

There are here several sources of error, which must be allowed for. The most important are these:—i. The magnetic axis of the needle may not coincide with its axis of figure; hence an error which is corrected by reversing the needle on its bearings. ii. The centre of gravity of the needle may not coincide with the axis of suspension, and then the angle dca is too great or too small, according as the centre of gravity is below or above the centre of suspension; for in the first case the action of gravity is in the same direction as that of the magnetic force, and in the second it is in the opposite direction. To correct this error, the poles of the needle must be reversed by remagnetising it in such a way that what was a north is now made a south pole. The inclination is now redetermined, and the mean taken of the results obtained in the two groups of operations. iii. The line of zeros may not be horizontal. To correct the error that would arise from this cause, the position of the needle is observed when the circle M is facing east, and also when it is facing west.

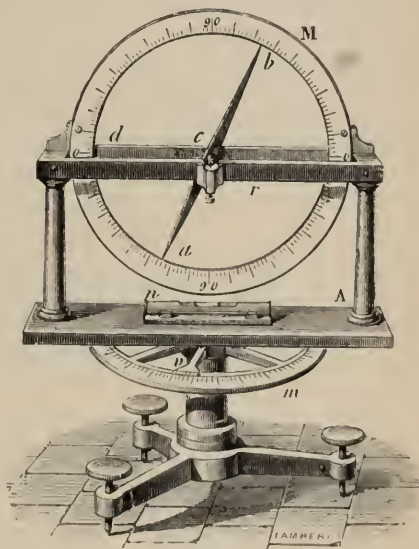

Fig. 703

The Kew dip circle is in principle like the instrument just described, but is more elaborate. The needle is 3 inches long and turns about an axle, consisting of a fine steel cylinder, resting on agate edges. The vertical circle is enclosed in a glass box, and the positions of the ends of the needles are observed by means of microscopes.

735. **Force of the earth's magnetism.**—If a magnetic needle is deflected from its position of equilibrium and left to itself, it will perform oscillations, which follow laws analogous to those of the pendulum (56). If the magnet is removed to another place, and caused to oscillate, a different frequency of oscillation will be observed; and the earth's magnetic forces in the two places will be respectively proportional to the squares of the number of oscillations in the same time.

If at M the number of oscillations in a minute had been $25 = n$, and at another place M', $24 = n'$, we should have (see art. 719)—

$$\frac{\text{Force of the earth's magnetism at M}}{\text{Force of the earth's magnetism at M'}} = \frac{n^2}{n'^2} = \frac{625}{576} = 1.085.$$

That is, if the force of the magnetism at the second place is taken as unity, that of the first is 1.085. If the magnetic condition of the needle had not

changed in the interval between the two observations, this method would give the relation of the forces at the two places.

In these determinations of the force, it would be necessary to observe the oscillations of the dip needle, which are produced by the total force of the earth's magnetism. These, however, are difficult to obtain with accuracy, and therefore those of the declination needle are usually taken. The force which makes the declination needle oscillate is only a portion of the total magnetic force, and is smaller in proportion as the inclination is greater. If a line $ac = T$ (fig. 704) represent the total force at the place M, the angle i the inclination, then the horizontal component $H = ab = T \cos i$. Hence, if n and n' represent the number of vibrations, in a given time, of a declination needle at the two places, at which the total forces are T T' respectively, we shall have—

$$\frac{T \cos i}{T' \cos i'} = \frac{n^2}{n'^2}; \text{ hence } \frac{T}{T'} = \frac{n^2 \cos i'}{n'^2 \cos i}$$

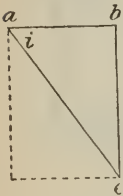

Fig. 704

That is to say, having observed in two different places the number of oscillations, n and n' , that the same needle makes in the same time, the ratio of the magnetic forces in the two places will be found by multiplying the ratio of the square of the number of oscillations by the inverse ratio of the cosines of the angle of dip.

Plate VI. is a chart representing the distribution of horizontal force over the earth's surface. The lines of equal horizontal force are somewhat irregular, especially in the neighbourhood of the equator and in extreme latitudes. The horizontal force diminishes as we proceed from the equator either northwards or southwards. If its value in the south of England is taken as unity, its maximum value (2.1) occurs in Borneo, and there is another maximum (1.9) on the west side of Panama. At the Cape of Good Hope the horizontal force is nearly the same as in England. Its change with place is most rapid in the region of Australia. When the angle of dip, i , is known, the total force T , or the vertical force Z , in any place, may be obtained from the values in the chart by the formula $T = H \sec i$; and $Z = H \tan i$.

The total force is least near the magnetic equator, and, increasing with the latitude, is greatest near, but not quite at, the magnetic poles; the places of maximum intensity are named the *magnetic foci*. There are two magnetic foci in the northern hemisphere, called respectively the American focus and the Siberian focus. The American focus is in north latitude 54° and longitude 94° W.; the Siberian focus in 66° north latitude and 115° east longitude. There are probably also two foci in the southern hemisphere which are near to the south magnetic pole and not far from each other.

The lines connecting places of equal total force are called *isodynamic lines*. They are not parallel to the magnetic equator, but seem to have about the same direction as the isothermal lines. According to Kuppfer, the force appears to diminish as the height of the place is greater; a needle which made one oscillation in 24 seconds vibrated more slowly by 0.01 of a second at a height of 1000 feet; but, according to Forbes, the force is only $\frac{1}{1000}$ less at a height of 3000 feet. There is, however, some

LINES OF EQUAL HORIZONTAL FORCE, 1900.

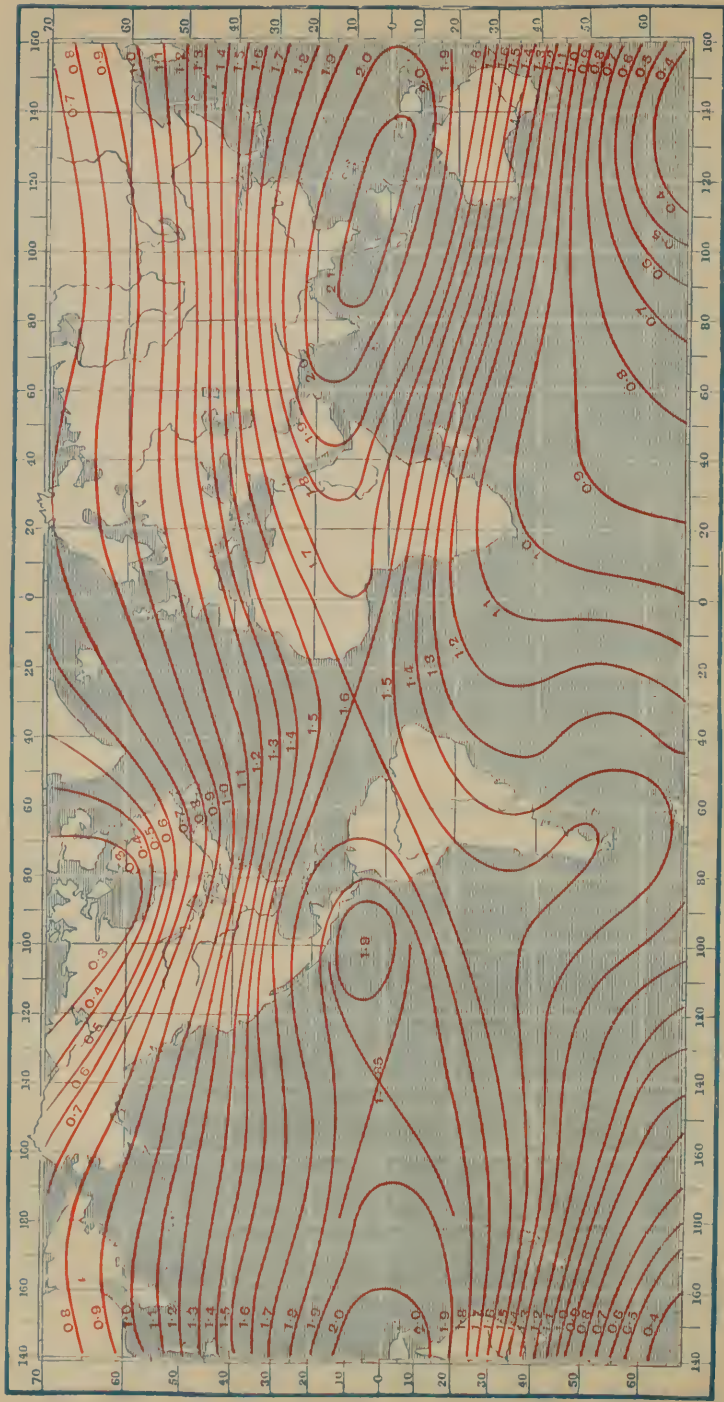

doubt as to the accuracy of these observations, owing to uncertainty as to the correction for temperature.

The intensity varies in the same place with the time of day: it attains its maximum between 4 and 5 in the afternoon, and is at its minimum between 10 and 11 in the morning.

It is probable, though it has not yet been ascertained with certainty, that the force undergoes secular variations. From measurements made at Kew it appears that on the whole the total force experiences a very slight annual increase.

736. Determination of the horizontal force in absolute measure.—The relative values of the earth's horizontal magnetic force at two places may be determined, as we have seen, by causing a compass needle, whose moment is assumed to remain constant, to vibrate at the two places and taking the ratio of the squares of the number of vibrations in a given time. The chart (Plate VI.) shows the distribution of horizontal force on the earth's surface for the year 1900, the force at London being taken as unity. But it is possible to determine the horizontal force in absolute measure—that is, in terms of the fundamental units of length, mass, and time—without referring to its value at any particular place, and without assuming the constancy of the moment of any particular magnet. For this purpose two experiments are necessary: (1) the *vibration* experiment, (2) the *deflection* experiment.

Vibration experiment.—When a bar magnet, suspended by a thread without torsion, and free to oscillate in a horizontal plane, is deflected from its position of equilibrium and then left to itself, it vibrates about this position, making oscillations which, if small, are isochronous like those of the pendulum. The frequency of these oscillations depends on the mass and dimensions of the bar, on its magnetic moment, and on the intensity of the earth's magnetism in the place of observation. The period, t , is given by the formula $t = 2\pi\sqrt{\frac{I}{HM}}$, where I is the moment of inertia (89A) of the magnet, M its magnetic moment, and H the horizontal force of the earth's magnetism. Hence

$$HM = \frac{4\pi^2 I}{t^2}.$$

The moment of inertia of a magnet may be determined from its mass and linear dimensions if the magnet is homogeneous in structure and of a regular geometrical shape; or it may be determined experimentally by first observing the time of oscillation of the magnet under the influence of the earth's magnetism, and then the time when it has been loaded with a mass the moment of inertia of which is known, and which does not alter the magnetic moment of the bar.

Now the value of HM depends on the nature of the bar, and on the force of the earth's magnetism in the place in question. If the magnetism of the bar were increased or diminished, or if the same bar were removed to a different locality, the product would have a different value. We must therefore find some independent relation between H and M , whereby M , the magnetic moment of the bar, may be got rid of, and an absolute value be obtained for H .

Such a relation may be obtained from the deflection which the bar magnet produces in a magnetic needle.

Deflection experiment.—Place the magnet, whose time of vibration has been determined, in the 'end on' position (723) with regard to a small compass needle, and note the deflection θ . It has been shown that with this arrangement $\frac{M}{H} = \frac{1}{2}r^3 \tan \theta$, where r is the distance between the centre of the magnet and the centre of the needle. The needle is usually provided with a mirror, and the lamp and scale arrangement described in art. 532 is used. The value of $\tan \theta$ is easily calculated from the observed deflection of the spot of light on the scale, and the distance of the scale from the needle. It is not necessary to know either the magnetic moment or any other property of the needle employed.

In the two equations which have now been obtained, viz.

$$MH = \frac{4\pi^2 I}{t^2}$$

$$\text{and } \frac{M}{H} = \frac{1}{2}r^3 \tan \theta,$$

the only unknown quantities are M and H . I has been evaluated once for all, t has been determined in seconds, $\tan \theta$ calculated from the observed deflection, and r measured in centimetres. Thus M and H are separately determined in absolute C.G.S. units :

$$H = \frac{2\pi}{t} \sqrt{\frac{2I}{r^3 \tan \theta}}$$

$$\text{and } M = \frac{\pi}{t} \sqrt{2r^3 I \tan \theta}.$$

Thus the same operations which determine H determine M also in absolute measure.

The total force is determined in absolute measure when the dip, i , is known, from the formula $T = \frac{H}{\cos i}$.

The value of H at Greenwich for the year 1905 is 0.185, that is, the horizontal magnetic field at Greenwich is such that a free unit magnetic (red) pole, submitted to its action, would begin to move in a horizontal northerly direction, and at the end of one second would have acquired a velocity of .185 cm. per second. The total force at the same place is .477. If British units—namely, the foot, grain, second—are employed, the unit of force is that which by acting for a second on a grain gives to it a velocity of a foot per second, and the unit magnetic pole is such that if placed one foot from another equal pole it repels it with a force equal to the unit just defined. To convert the value of H , when expressed in centimetres, grammes, and seconds, into the equivalent value referred to British units, we must multiply by 21.69. In like manner, to convert magnetic forces referred to British units into the corresponding values expressed in centimetres, grammes, and seconds, we must multiply by $0.0461 = \frac{1}{21.69}$.

737. **Dimensions of magnetic magnitudes.**—The dimensions of force, momentum, energy, &c., in terms of length L , time T , and mass M , were given in art. 63. From these we can readily deduce the dimensions of magnetic magnitudes. From Coulomb's law we have $F = \frac{m^2}{r^2}$, where F is the force between two magnetic poles, each of strength m . Now the dimensions of F are $\frac{ML}{T^2}$, \therefore the dimensions of magnetic pole, m , are $\sqrt{\frac{ML}{T^2}} \cdot L^2$ or

$$\frac{M^{\frac{1}{2}} L^{\frac{3}{2}}}{T}$$

Again, the magnetic force at a point in a magnetic field was defined (720) as the force on the unit pole at that point. Hence,

$$\text{magnetic force} = \frac{\text{mechanical force}}{\text{pole}},$$

and its dimensions are $\frac{ML}{T^2} \times \frac{T}{M^{\frac{1}{2}} L^{\frac{3}{2}}} = M^{\frac{1}{2}} L^{-\frac{1}{2}} T^{-1}$.

Let N be the number of lines of force passing through an area A , H the number per square centimetre of that area, then $N = AH$. Hence,

dimensions of magnetic flux = $L^2 \times \frac{M^{\frac{1}{2}} L^{-\frac{1}{2}}}{T} = \frac{M^{\frac{1}{2}} L^{\frac{3}{2}}}{T}$. See also art. 1000.

738. **Magnetic observatories.**—During the last few years great attention has been devoted to the observation of the magnetic elements, and observatories for this purpose have been fitted up in different parts of the globe. These observations have led to the discovery that the magnetism of the earth is in a state of constant fluctuation, like the waves of the sea or the pressure of the atmosphere. In studying the variations of the declination, &c., the mean of a great number of observations must be taken, so as to eliminate irregular disturbances and bring out the general laws.

The principle on which magnetic observations are automatically recorded is as follows:—Suppose that in a dark room a bar magnet is suspended horizontally, and at its centre is a small mirror; suppose further that a lamp sends a ray of light to this mirror, the inclination of which is such that the ray is reflected, and is received on a horizontal drum placed underneath the lamp. The axis of the drum is at right angles to the axis of the magnet; it is covered with sensitive photographic paper, and is rotated uniformly by clockwork. If now the magnet is quite stationary, as the drum rotates, the reflected spot of light will trace a straight line on the paper with which the revolving drum is covered. But if, as is always the case, the position of the magnet varies during the twenty-four hours, the effect will be to trace a sinuous line on the paper. These lines can afterwards be fixed by ordinary photographic methods. If we know the distance of the mirror from the drum, and the length of the paper band which comes under the influence of the spot of light in a given time—twenty-four hours, for instance—the angular deflection at any given moment may be deduced by a simple calculation (532).

The observations made in the English magnetic observatories were reduced by Sabine, and revealed some curious facts in reference to magnetic storms and the daily range of magnetic declination. He found that the latter exhibits a certain periodicity, and attains its greatest value about every ten years. Independently of this, Schwabe, who for many years studied the subject, found that the spots on the sun, seen on looking at it through a coloured glass, vary in their number, size, and frequency, but attain their maximum about every ten or eleven years. Now Sabine established the interesting fact that the period of their greatest frequency coincides with the period of greatest mean daily range of declination. Another phenomenon is the simultaneous occurrence of magnetic perturbations in very distant countries. Thus Sabine mentioned a magnetic disturbance which was felt simultaneously at Toronto, the Cape, Prague, and Van Diemen's Land. Such simultaneous perturbations have received the name of *magnetic storms*. Other remarkable connections between the sun and terrestrial magnetism have been observed; one, especially, of recent occurrence has attracted considerable attention. It was the flight of a large luminous mass across a vast sunspot, while a simultaneous perturbation of the magnetic needle was observed in the observatory at Kew; subsequent examination of magnetic observations in various parts of the world showed that within a few hours one of the most violent magnetic storms ever known had prevailed.

It seems, however, that these accidental variations in the declination cannot be due to changes in any *direct* action of a possible magnetic condition of either the sun or the moon. For it can be shown that if the magnetisation of the latter were as powerful as that of the earth, the deflection which it could produce would not amount to the $\frac{1}{20}$ th of a second, a quantity which cannot be measured. In order to produce a variation of $10'$, such as is frequently met with, the magnetisation of the sun or of the moon must be 12,000 times that of the earth; in other words, a more powerful degree of magnetisation than that of powerfully magnetised steel bars.

Magnetic storms are nearly always accompanied by the exhibition of the aurora borealis in high latitudes; that this is not universal may be due to the fact that many auroras escape notice. The converse of this is true, that no great display of the aurora takes place without a violent magnetic storm.

The occurrence of a magnetic storm is also almost invariably accompanied by the flow of earth currents (920). Such currents, which have often so prejudicial an action on telegraph lines, are continuously recorded at the Greenwich Observatory. The prevailing direction is NE and SW.

The centre or focus towards which the rays of the aurora converge lies approximately in the prolongation of the direction of the dipping-needle; and it may be mentioned in this connection that the appearances of the aurora borealis have the same periods as the sunspots.

739. **Magnetisation by the action of the earth.**—The action of the earth on magnetic substances resembles that of a magnet, and hence the terrestrial magnetism is constantly tending to produce magnetisation in soft iron and in steel. But as the coercive force is very considerable in the

latter substance, the action of the earth is inadequate to produce more than slight magnetisation. This is not the case with perfectly soft iron. When a bar of this metal is held in the magnetic meridian parallel to the dip needle, the bar becomes at once endowed with magnetic polarity. The lower extremity is a north pole, and if the north pole of a small magnetic needle is approached, it will be repelled. This magnetism is of course only temporary, for if the bar is turned the poles are inverted, as pure soft iron is nearly destitute of coercive force.

While the bar is still vertical, a certain amount of coercive force may be imparted to it by giving it several smart blows with a hammer, and the bar retains for a time the magnetism which it has thus obtained. But the coercive force thus developed is very small, and the magnetism disappears when the iron, while held in a position in which no new magnetic force acts upon it, is struck.

If a bar of soft iron is twisted while held vertically, or, better, at the angle of dip, it acquires a feeble permanent or subpermanent magnetisation.

It is this magnetising action of the earth which develops the magnetism frequently observed in steel and iron instruments, such as fire-irons, rifles, lamp-posts, railings, gates, lightning conductors, &c., which remain for some time in a more or less vertical position. They become magnetised with their north pole downwards, just as if placed over the pole of a powerful magnet. The magnetism of native black iron oxide (694) has doubtless been produced by the same cause; the very different magnetic power of different specimens being partly attributable to the different positions of the veins of ore with regard to the line of dip. The ordinary irons of commerce are not quite pure, and possess a feeble coercive force; hence a feeble magnetic polarity is generally found to be possessed by the tools in a smith's shop. Cast iron, too, has usually a great coercive force, and can be permanently magnetised. The turnings, also, of wrought iron and of steel produced by the powerful lathes of our ironworks are found to be magnetised.

740. **Deviation of the compass in iron ships.**—The magnetic properties of the mild steel now so largely used in the construction of ships are similar to those of soft iron, which was at one time generally employed. The coercive force of mild steel is small and its permeability considerable. A vertical plate of such steel placed in the magnetic meridian, in the northern hemisphere, will become magnetised, by the inductive action of the earth, with blue polarity in the upper part and towards the south, and with red polarity in the lower part and towards the north. the neutral line being at right angles to the earth's total force.

Each plate which enters into the construction of an iron or steel ship is subjected to much mechanical violence in the processes of hammering, boring, riveting, &c., and consequently acquires an increased coercive force (702), and retains the induced magnetism. The ship, which is the aggregate of the steel and iron plates and masses used in its construction, becomes a huge magnet, and its magnetism is to a considerable extent *permanent*. The direction of its polarity depends upon its position in building. If it has been built head north, the bow will have red and the stern blue magnetism—blue magnetism always predominating in the upper part and red towards the keel, if the ship has been built in the northern hemisphere.

Here, then, is a cause of deviation of the compass. Let us suppose, to take an example, that the ship has a blue pole near the bow and a red pole near the stern. In these circumstances there will be no error of the compass when the ship is sailing in a northerly (magnetic) direction; but if she turns eastwards the red end of the compass needle will be pulled towards the east, and the error will increase to a maximum, and then diminish to zero, as the ship's head turns from north, through east, to south. In the whole of this semicircle the error is easterly; in the remaining semicircle it is westerly. Hence, the error of the compass due to this cause is called *semicircular*, since it changes its sign in each semicircle.

This error is compensated by placing hard steel magnets in the binnacle under the compass bowl, in such number and at such distances that the field they produce at the position of the compass needles is exactly equal and opposite to that produced by the permanent magnetism of the ship.

Error of the compass is brought about not only by the permanent magnetism of the ship, but by magnetism temporarily induced in vertical or horizontal masses of iron or steel in the ship, due to the vertical or horizontal components of the earth's magnetic force.

Consider, first, vertical masses—the sides of the ship, steel ribs, masts, funnels, davits, &c.—acted on by the vertical component Z (735).

Each becomes a magnet with blue polarity at the top (in the northern hemisphere) and red polarity at the bottom. The effect of all these vertical magnets on the compass will depend upon the position of the latter in the ship, but in any case is such as could be produced by a single vertical rod of iron suitably placed. Assuming all the iron of the ship to be symmetrically placed with regard to the central vertical fore-and-aft plane of the ship, the resultant vertical rod will be in this plane, and the error it causes will be semicircular in character, being zero at N and S and a maximum near the east and west points, but of opposite signs in the east and west semicircles.

The error due to this cause is corrected by a vertical bar of soft iron called a *Flinders bar*—placed immediately forward of or immediately abaft the binnacle, with its upper or lower end on a level with the needles of the compass, and of such length as to produce exact compensation. Sometimes the length of the Flinders bar is fixed, and its distance from the binnacle variable. In the Royal Navy the Flinders bar is fixed in position, but its length may be varied from 24 inches downward.

The error due to induction in vertical iron vanishes at the magnetic equator, where Z , the vertical component, = 0. It varies with the tangent of the dip. In the southern hemisphere the sign of the error changes.

Horizontal masses of iron acted on by the earth's horizontal force become temporarily magnetised with red polarity towards the north and blue towards the south, and produce an effect on the compass which a little consideration will show to be a maximum at the intercardinal points NE, SE, SW, and NW, and to vanish at the cardinal points N, E, S, W. The error due to this cause is called *quadrantal*, because it changes sign in every quadrant: if it is to the east when the ship's head is in the NE quadrant, it will be to the west in the SE quadrant, to the east in the SW, and to the west again in the NW.

The error due to this cause is for a given ship the same in all parts of the world, for although the induced magnetism increases with the horizontal force, the tendency of the compass to return to the meridian increases in the same ratio. Hence the error is constant, and if compensated by suitably placed masses of iron—generally iron spheres attached to the port and starboard sides of the binnacle—at any one place, is compensated for all parts of the world.

It was stated above that the magnetism acquired by an iron or steel ship in the process of building is permanent. This is not strictly correct, for a certain proportion of it is generally lost during the first voyage, being shaken out by the buffeting of the waves and the vibration of the engines. The magnetism which remains undergoes very little subsequent diminution, and this is called its *permanent* magnetism, in opposition to the *subpermanent* which it loses.

Before a ship leaves port for a long voyage, she is 'swung for the adjustment of compasses.' The process consists in observing the direction of the standard compass on board, as the ship's head points N, NE, E, &c., and comparing it with that of an undisturbed compass on shore. In this way the error of the compass on each point is ascertained and a table of errors drawn. By analysis of this table the navigating officer finds out how much of the error is due to the permanent magnetism of the ship and how much to temporary induction in vertical and horizontal iron. The several errors are compensated (1) by permanent magnets in the binnacle, (2) by a Flinders bar, and (3) by the port and starboard iron spheres.

BOOK IX

FRICTIONAL ELECTRICITY

CHAPTER I

FUNDAMENTAL PRINCIPLES

741. **Electricity. Its nature.**—Electricity is a powerful physical agent which manifests itself mainly by attraction and repulsion, but also by luminous and heating effects, by violent shocks, by chemical decomposition, and many other phenomena. It is evoked in bodies by a variety of causes, among which are friction, pressure, chemical action, heat and magnetism.

Thales, 600 B.C., knew that when *amber* was rubbed with silk it acquired the property of attracting light bodies; and from the Greek word (*ἤλεκτρον*) for this substance the term *electricity* has been derived. This is nearly all the knowledge left by the ancients; it was not until towards the end of the sixteenth century that Dr. Gilbert, physician to Queen Elizabeth, showed that this property was not limited to amber, but that other bodies, such as sulphur, wax, glass, &c., also possessed it in a greater or less degree.

742. **Development of electricity by friction.**—When a glass rod, or a stick of sealing-wax or shellac, is held in the hand, and is rubbed with a piece of flannel or with the skin of a cat, the parts rubbed will be found to have the property of attracting light bodies, such as pieces of silk, wool, feathers, paper, bran, gold leaf, &c., which, after remaining a short time in contact, are again repelled. They are then said to have become *electrified*. In order to ascertain whether bodies are electrified or not, instruments called *electroscopes* are used. The simplest of these, the *electric pendulum* (fig. 705), consists of a pith ball attached by means of a silk thread to a glass support. When an electrified body is brought near the pith ball, the latter is instantly attracted, but after momentary contact is again repelled (fig. 706).

A solid body may also be electrified by friction with a liquid or with a gas. In the Torricellian vacuum a movement of the mercury against the sides of the glass produces a disengagement of electric light visible in the dark; a tube exhausted of air, but containing a few drops of mercury, becomes also luminous when agitated in the dark.

If a quantity of mercury in a dry glass vessel is connected with a gold-

leaf electroscope (748) by a wire, and a dry glass rod be immersed in it, no indications are observed during the immersion, but on smartly withdrawing the rod, the leaves increasingly diverge, attaining their maximum when the rod leaves the mercury.

Some substances, particularly metals, do not seem capable of receiving the electric excitement. When a rod of metal is held in the hand, and

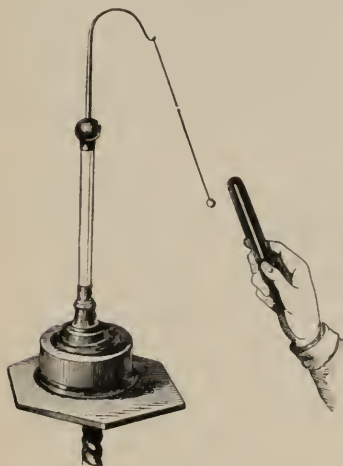

Fig. 705



Fig. 706

rubbed with silk or flannel, no electric effects are produced in it ; and bodies were divided by Gilbert into *idioelectrics*, or those which become electrified by friction ; and *anelectrics*, or those which do not possess this property. These distinctions no longer obtain in any absolute sense ; under appropriate conditions, all bodies may be electrified by friction (743).

743. **Conductors and nonconductors.**—When a dry glass rod, rubbed at one end, is brought near an electroscope, it will be seen that that part only is electrified which has been rubbed ; the other end produces neither attraction nor repulsion. The same is the case with a rod of shellac or of sealing-wax. In these bodies electricity does not pass from one part to another—they do not *conduct* electricity. Experiment shows that when a metal has received electricity in any of its parts the electricity instantly spreads over its entire surface. Metals are hence said to be good *conductors* of electricity.

Bodies have, accordingly, been divided into *conductors* and *nonconductors* or *insulators*. This distinction is not absolute, and we may advantageously consider bodies as offering a *resistance* to the passage of electricity which varies with the nature of the substance. Those bodies which offer little resistance are conductors, and those which offer great resistance are nonconductors or insulators : electric *conductivity* is accordingly the inverse of electric *resistance*. There is no such thing as an absolute nonconductor of electricity, any more than there is an absolute nonconductor of heat.

We are to consider that between conductors and nonconductors there is a *quantitative* and not a *qualitative* difference ; there is no conductor so good but that it offers some resistance to the passage of electricity, nor is there any substance which insulates so completely but that it allows some electricity to pass. The transition from conductors to nonconductors is gradual, and no line of sharp demarcation can be drawn between them.

In this sense we are to understand the following table, in which bodies are conveniently classed as *conductors*, *semiconductors*, and *nonconductors* ; those bodies being designated as conductors which, when applied to a charged electroscope, discharge it almost instantaneously ; semiconductors being those which discharge it in a short but measurable time—a few seconds, for instance ; while nonconductors effect no perceptible discharge in the course of a minute.

<i>Conductors</i>	<i>Semiconductors</i>	<i>Nonconductors</i>
Metals.	Alcohol and ether	Dry oxides.
Well-burnt charcoal.	Powdered glass.	Ice at -25° C.
Graphite.	Flour of sulphur.	Lime.
Acids.	Dry wood.	India rubber.
Aqueous solutions.	Paper.	Air and dry gases.
Water.	Ice at 0° .	Dry paper.
Snow.		Silk.
Vegetables.		Diamonds and precious stones.
Animals.		Glass.
Soluble salts.		Wax.
Linen.		Sulphur.
Cotton.		Resin.
		Amber.
		Shellac.

This list is arranged in the order of decreasing conductivity, or, what is the same thing, of increasing resistance. The arrangement, however, is not invariable. Conductivity depends on many physical conditions. Glass, for example, which does not conduct at ordinary temperatures, does so at 200° to 300° C. To show this, platinum wire is coiled on a glass rod to within a couple of inches from the end. If the finger touches the coiled part, and the free end when at the ordinary temperature is applied to a charged electroscope, it does not affect it ; but if the free end is heated in a Bunsen flame, it will now be found to discharge the electroscope. Shellac and resin do not insulate so well when they are heated. Water, which is a good conductor, conducts but little in the state of ice at 0° , and very badly at -25° . Powdered glass and flour of sulphur conduct very well, while in compact masses they are nonconductors ; probably because in a state of powder each particle becomes covered with a film of moisture that acts as a conductor. The nonconducting power of glass is also greatly influenced by its chemical composition. Some specimens have an appreciable conductivity even if dry, and at the ordinary temperature.

744. **Insulating bodies. Common reservoir.**—Bad conductors are called *insulators*, for they are used as supports for bodies in which electricity is to be retained. A conductor remains electrified only so long as it is surrounded by insulators. If this were not the case, as soon as the electrified body came in contact with the earth, which is a good conductor, the electricity would pass into the earth, and diffuse itself through its whole extent. On this account, the earth has been named the *common reservoir*. A body is insulated by being placed on a support with glass feet, or on a cake of resin, or by being suspended by silk threads. No bodies, however, insulate perfectly; all electrified bodies lose their electricity more or less rapidly by means of the supports on which they rest. An *insulating stand* consists of a metal or wooden disc, or platform, supported on a pillar of some insulating material. If this material is glass it should be washed in dilute acid (to get rid of any adhering alkali) and in water, dried, and coated with a thin layer of shellac varnish to prevent deposition of moisture on it. Ebonite is frequently used for insulating purposes, but it ceases to insulate after long exposure to light, owing to the formation of a thin film of sulphuric acid (due to the action of oxygen and moisture on the sulphur of the ebonite) on its surface. Brown shellac and paraffin wax are excellent insulators. The loss of electricity from a charged conductor in a moist atmosphere is due chiefly to leakage by the support, and not to the conductivity of the moist air.

Mascarp's insulator is admirably adapted for supporting bodies charged with electricity. It consists of a glass vessel of special shape (fig. 707), to the glass vase of which is fused the stem. This passes through the neck and supports the plate, P; the neck is protected by an ebonite screen C, and inside the vessel is strong sulphuric acid, so that the stem A is always dry.

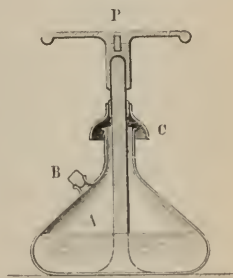

Fig. 707

From their great conductivity metals do not seem to become electrified by friction. But if they are insulated, by being held in the hand by an india-rubber glove or a silk handkerchief and then rubbed, they give good indications. This may also be seen by the following experiment (fig. 708). A brass tube is provided with a glass handle by which it is held, and is then rubbed with silk or flannel. When the metal is brought near an electric pendulum (fig. 705) the pith ball is attracted. If the metal is held in the hand, electricity is indeed produced by friction—but it immediately passes through the body into the ground.



Fig. 708

If, too, the cap of a gold-leaf electroscope is briskly flapped with a dry silk handkerchief, the gold leaves will diverge.

745. **Distinction of the two kinds of electricity.**—When a glass rod is rubbed with silk, both glass and silk are electrified, for each attracts a pith-ball pendulum when brought near to it. To ensure success in this experiment the operator should wear an india-rubber glove, for the purpose of insulating

the silk ; otherwise the electricity developed on it may escape to the floor of the room. The pith ball after contact with the glass rod is repelled by it, but is still attracted by the silk. Similarly, if when the pith ball is neutral the silk touches it, the ball acquires some of the electricity of the silk and is repelled by it, though it is attracted by the glass rod. If instead of glass and silk we make the experiments with sealing-wax and flannel, we find that both these substances become electrified by friction with each other, and that the pith ball when charged by contact with the sealing-wax is repelled by it, and attracted by the flannel, while, if it has first touched the charged flannel, it is repelled by the flannel and attracted by the sealing-wax. Further, if glass is rubbed with silk and sealing-wax with flannel, the pith ball, after touching the glass, is repelled by the glass and attracted by the sealing-wax, and after touching the sealing-wax, is repelled by it and attracted by the glass.

By experiments of this nature it becomes clear that we must distinguish between two kinds of electrification, and recognise that the glass and silk are differently electrified, as are also wax and flannel, but that the kind of electrification developed on the glass by friction with silk is of the same kind as that developed on flannel when it is made to rub sealing-wax, and also that the electricities produced on the sealing-wax and on the silk are identical. Dufay gave the names *vitreous* and *resinous* to these two respectively.

746. **Theories of electricity.**—To account for the different effects of electricity, Franklin supposed that there exists a peculiar, subtle, imponderable fluid, which acts by repulsion on its own particles, and pervades all matter. This fluid is present in every substance in a quantity peculiar to it, and when the substance contains this normal quantity it is in the natural, or unelectrified, state. When two substances are rubbed together, the one acquires an additional quantity of the fluid, and is said to be *positively* electrified ; the other loses an equal quantity, and is said to be *negatively* electrified. Positive electricity is represented by the sign +, and negative electricity by the sign - ; a designation based on the algebraical principle, that when a plus quantity is added to an equal minus quantity zero is produced.

The *theory of Symmer* assumes that every substance contains an indefinite quantity of a subtle, imponderable matter, which is called the electric fluid. This fluid is formed by the union of two fluids—the *positive* and the *negative*. When they are combined they neutralise each other, and the body is then in the natural or neutral state. By friction, and by several other means, the two fluids may be separated, but one of them can never be excited without a simultaneous production of the other. There may, however, be a greater or less excess of the one or the other in any body, and it is then said to be electrified *positively* or *negatively*. As in Franklin's theory, *vitreous* corresponds to *positive* and *resinous* to *negative* electricity. This distinction is merely conventional : it is adopted for the sake of convenience, and there is no other reason why resinous electricity should not be called positive electricity.

It must be added that these theories are quite hypothetical ; but for purposes of instruction the adoption of one or other of them is for the present justified by the convenient explanation which they give of electric phenomena.

747. **Attraction and repulsion.**—The phenomena of attraction and repulsion may be enunciated in the following law :—

Two bodies charged with the same electricity repel each other; two bodies charged with opposite electricities attract each other.

These attractions and repulsions take place in virtue of the action which the two electricities exert on themselves, and not in virtue of their action on the particles of matter.

The repulsion between similarly electrified bodies may be exhibited in the following experiments :—

i. If the pith balls, A and B (fig. 709), are suspended, close together, by long silk fibres, and a charged glass rod is brought up from below, as soon as the pith balls touch the glass they are both charged with + electricity, and repel each other to the positions A' B'.

ii. Hold a narrow strip of silk ribbon, a yard long, by its middle, so that the two halves hang vertical in the unelectricified state. When electrified by friction with india rubber they stand out from each other at an angle, both being charged with the same (positive) electricity. To secure this result, a good plan is to cover the first and second fingers of the right hand with pieces of large rubber tubing and to pass the ribbon between them.

A similar experiment may be made with a strip of gutta-percha tissue by passing it between the fingers.

748. **Gold-leaf electroscope.**—An electroscope is an apparatus (i) for detecting the presence of electrification, and (ii) for indicating differences of potential (757). The gold-leaf electroscope is much more sensitive as a detector of electrification than the pith-ball pendulum which has so far been used.

A convenient form of it, and one which may be used for lantern projection, consists of a brass cylinder A (fig. 710), about 10 cm. in diameter, with plate-glass ends 8 cm. apart. It is surmounted by a short brass tube plugged with paraffin wax, through the centre of which passes a brass rod. This rod has a small brass ball, *a*, at the top, and at the bottom carries two parallel strips of gold-leaf 3 cm. long and .5 cm. broad. The part *d* of the rod which supports the cylinder is made of ebonite, so that when necessary the brass case may be insulated from the ground. The rod below *d* fits into a tube *g*, and can be clamped so that the gold leaves may be at any desired height from the table. Fine copper wires are drawn horizontally across the inner sides of the glass ends of the cylinder, the object being to surround the gold leaves with a metallic environment, all parts of which are connected together, and may be earthed when necessary. There is a small hole at the

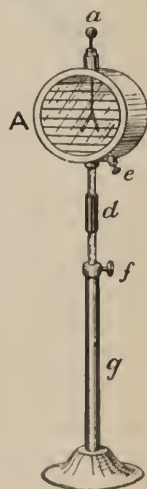
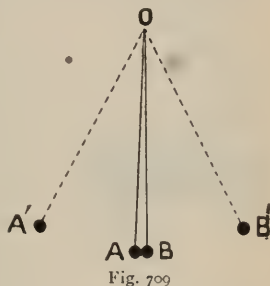

Fig. 710

top of *a* for the insertion of a wire, and *e* is a binding screw for making connection with the lower part of the stand, which is earth-connected. When the instrument is used for projection, the cylinder is clamped so that the gold leaves are at the level of the centre of the lantern lenses, and an image of the leaves is thrown on a distant screen by a converging lens.

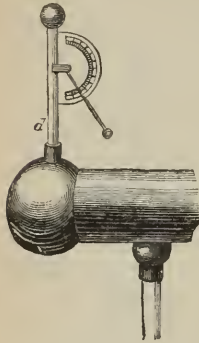

Fig. 711

Other forms of the gold-leaf electroscope are seen in figs. 730 and 732.

The electric condition of a conductor whose charge is relatively large may be roughly indicated by *Henley's quadrant electroscope* or *electrometer*. This is a small electric pendulum, consisting of a wooden or metal rod *a*, to which is attached an ivory scale (fig. 711). In the centre of this is a small index of straw, movable on an axis, and terminating in a pith ball. Being attached to the conductor, the index diverges as the conductor is charged, ceasing to rise when the limit is attained.

749. Law of the development of electricity by friction.—Whenever two substances are rubbed together the neutral state is disturbed, and electricity, according to Franklin's theory, passes over from the one to the other, so that the first has a defect of electricity and is negatively charged; the second has an excess, and is positively charged. According to Symmer's theory, we should say that by the friction the neutral fluid of both substances is decomposed into positive and negative fluids, that the positive of the first passes over to the second and the negative of the second to the first, so that after the friction the first has negative fluid and the second positive. That the charges of the two are equal and opposite may be proved by the following experiment devised by Faraday:—A small flannel cap provided with a silk thread (fig. 712) is fitted on the end of a stout rod of shellac, and rubbed round a few times.

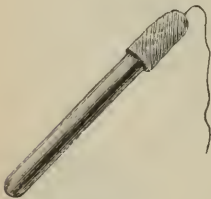

Fig. 712

When the cap is removed by means of the silk thread, and presented to a pith-ball pendulum charged with positive electricity, the latter will be repelled, proving that the flannel is charged with positive electricity; while if the shellac is presented to the pith ball, it will be attracted, showing that the shellac is charged with negative electricity. Both electricities are present in equal quantities; for if the rod is presented to the electroscopes before removing the cap, no action is observed.

In like manner if the rod and the cap after being rubbed and separated are simultaneously placed in a Faraday's cylinder connected with an electroscope (764), no effect is produced on the electroscope.

The electricity developed on a body by friction depends on the rubber as well as the body rubbed. Thus glass becomes negatively electrified when rubbed with catskin, but positively when rubbed with silk. In the following list, which is mainly due to Faraday, the substances are arranged in such an order that each becomes positively electrified when rubbed with any of

the bodies following, but negatively when rubbed with any of those which precede it :—

- | | | | |
|------------------|--------------|-------------------|-------------------|
| 1. Catskin. | 5. Glass. | 9. Wood. | 13. Resin. |
| 2. Flannel. | 6. Cotton. | 10. Metals. | 14. Sulphur. |
| 3. Ivory. | 7. Silk. | 11. India rubber. | 15. Gutta-percha. |
| 4. Rock crystal. | 8. The hand. | 12. Sealing-wax. | 16. Gun-cotton. |

The nature of the electrification by friction depends also on the degree of polish, the direction of the friction, and the temperature. If two glass discs of different degrees of polish are rubbed against each other, that which is most polished is positively, and that which is least polished is negatively, electrified. If two silk ribbons of the same kind are rubbed across each other, that which is transversely rubbed is negatively and the other positively electrified. If two bodies of the same substance, of the same polish, but of different temperatures, are rubbed together, that which is most heated is negatively electrified.

Poggendorff observed that many substances which have hitherto been regarded as highly negative, such as gun-paper, gun-cotton, and ebonite, yield positive electricity when rubbed with leather coated with amalgam (769). It must be added that the results of experiments on the kind of electricity produced by rubbing bodies together are somewhat uncertain, as slight differences in the surfaces of the bodies rubbed may completely alter their deportment. A valuable source of negative electricity is a strip of pyroxyline or gun-paper, or a strip of celluloid, either of which produces it by being simply drawn through the fingers.

750. Other sources of electrification.—Electric excitement may be produced by other causes than friction. If a disc of wood, covered with silk, on which some amalgam (769) has been rubbed, and a metal disc, each provided with an insulating handle, are placed in contact, and then suddenly separated, the metal disc is negatively electrified. A crystal of Iceland spar pressed between the fingers becomes positively electrified, and retains this state for some time. The same property is observed in several other minerals, even though conductors, provided they are insulated. If cork and india rubber are pressed together, the first becomes positively and the latter negatively electrified. A disc of wood pressed on an orange and separated carries away a good charge of electricity if the contact is rapidly interrupted. But if the disc is slowly removed the quantity is smaller, for the two charges recombine at the moment of their separation. For this reason there is no apparent effect when the two bodies pressed together are good conductors.]

The contact of heterogeneous bodies is no doubt the source of electricity. According to the investigations of Christiansen and of J. J. Thomson, there seems no doubt that in electrification the resultant charges owe their origin to the loosening or destruction of the connection of the atoms. Pressure and friction are but particular cases : in the former case the contact is closer, and in the latter case the surfaces are being continually renewed ; the effect is the same as if there were a series of rapidly succeeding contacts.

Cleavage also is a source of electricity. If a plate of mica is rapidly split in the dark, a slight phosphorescent light is perceived. Becquerel

fixed glass handles to each side of a plate of mica, and then rapidly separated them. On presenting each of the plates thus separated to an electroscope, he found that one was negatively and the other positively electrified. If a stick of sealing-wax is broken, the ends exhibit different electricities.

All badly conducted crystalline substances exhibit electric indications by cleavage. The separated plates are always in opposite electric conditions, provided they are not good conductors; for if they were, the separation would not be sufficiently rapid to prevent the recombination of the two electricities. With the phenomena here described must be classed the luminous appearance seen in the dark when sugar is broken. If sulphur or resin is melted in glass vessels and a glass rod is placed in the melted mass, on cooling the solid mass can be lifted out, and will be found to be negatively electrified.

751. Pyroelectricity.—Certain minerals, when warmed, acquire electric properties: a phenomenon to which the name *pyroelectricity* is given. It is best studied in *tourmaline*, in which it was first discovered, from the fact that this mineral has the power of first attracting and then repelling hot ashes when placed among them.

To observe this phenomenon, a crystal of tourmaline (fig. 713) is suspended horizontally by a silk thread, in a glass cylinder placed on a heated metal plate, or in an ordinary hot-air bath. On subsequently investigating



Fig. 713!

the electric condition of the ends by approaching to them successively an electrified glass rod, one end will be found to be positively electrified, and the other end negatively electrified, and each end shows this polarity as long as the temperature rises. The arrangement of the electricity is thus like that of the magnetism in a magnet. The points at which the intensity of free electricity is greatest are called the *poles*, and the line connecting them is the *electric axis*. When a tourmaline, while thus electrified, is broken in the middle, each of the pieces has its two poles, and the polarities of the broken ends are opposite, resembling thus the experiment of the broken magnets (697). The quantities of electricity produced when tourmaline is heated are equal as well as opposite, for if a heated crystal is suspended by an insulating support inside an insulated metal cylinder, the outside of which is connected with an electroscope (764), no divergence in its leaves is produced.

These polar properties depend on the *change* of temperature. When a tourmaline, which has become electric by being warmed, is allowed to cool slowly, it first loses electricity, and then its polarity becomes reversed; that is, the end which was positive now becomes negative, and that which was negative becomes positive, and the position of the poles now remains unchanged as long as the temperature sinks. Tourmaline only becomes pyroelectric within certain limits of temperature; these vary somewhat with the length, but are usually between 10° and 150° C. Below and above these temperatures it behaves like any other body, and shows no polarity.

Besides tourmaline the following minerals are found to be pyroelectric, though not so markedly—boracite, topaz, prehnite, silicate of zinc, scolezite,

axenite. And the following organic bodies are pyroelectric—cane-sugar, Pasteur's salt (sodium-ammonium racemate), potassium tartrate, &c.

Lord Kelvin supposes that every portion of tourmaline and other hemihedral crystals possesses a definite electric polarity, the intensity of which depends on the temperature. When the surface is passed through a flame every part becomes electrified to such an extent as to exactly neutralise, for all external points, the effect of the internal polarity. The crystal thus has no external action, nor any tendency to change its mode of electrification. But if it is heated or cooled the internal polarisation of each particle of the crystal is altered, and can no longer be balanced by the superficial electrification, so that there is a resultant external action.

A very convenient, and at the same time sensitive, means of investigating the action of heat on crystals is to sift on these, after having been warmed, a mixture of flour of sulphur and red lead through a small cotton sieve. By the friction in sifting the sulphur acquires negative and the red lead positive electricity, and the powders thus charged attach themselves to those parts of the crystal which have the opposite electricity, and thus by their different colours give at once an image of the distribution of its electricities.

Crystals of fluor-spar are electrified not only by heat but also when they are exposed to radiation from the sun and from the electric light. Electricity produced in this way is known as *photo-electricity*.

A transparent specimen of rock crystal when exposed to the sun's rays becomes electrified, the edges of the prism being alternately positive and negative. An insulated metal plate exposed to the sun's rays becomes highly charged.

Mechanical compression and extension produce electrification in tourmaline. If a prism be cut with its long axis parallel to the principal crystallographic axis, and this is compressed, the terminal faces are of opposite electricities as if the crystal had been cooled. In like manner, if the crystal is stretched, the effects are as if it had been warmed. Such effects are classified as being due to *piezo-electricity*.

CHAPTER II

QUANTITATIVE LAWS OF ELECTRIC ACTION. DISTRIBUTION

752. **Electric quantity or charge.**—In the experiment with the flannel cap, described above (749), each time the experiment is made, the quantity of positive electricity produced, which remains on the flannel, is equal to that of the negative electricity, which remains on the sealing-wax. The flannel, with its charge of positive electricity, may be detached, and if we work under precisely uniform conditions, equal *quantities* of electricity can thus be separated.

If we fill a cask with water by means of a measure, the quantity added would be directly proportional to the number of such measures. Now although in the above experiment the quantities of electricity produced each time are equal, yet when the flannel cap is applied each time to an insulated conductor it does not necessarily follow that the quantity of electricity imparted is directly proportional to the number of such applications.

The C.G.S. unit of electric quantity or charge is defined as follows:—If two small spheres are charged with equal quantities of positive electricity, and placed with their centres 1 cm. apart in air, they will repel each other with a certain force, and if the quantities are altered (still being kept equal to each other), until the force of repulsion is exactly one dyne (63), each quantity is the C.G.S. unit of quantity. Thus, the unit charge of electricity is that charge which, situated at a point or on a very small sphere, repels an equal charge, on the surface of another small sphere, with a force of one dyne, the distance between the centres of the spheres being 1 cm. Compare with this the definition of unit magnetic pole (720).

753. **Laws of electric attraction and repulsion.**—The laws which regulate the attraction and repulsion of electrified bodies may be thus stated:—

I. *The repulsion or attraction between two small electrified spheres is in the inverse ratio of the squares of the distances of their centres.*

II. *The distance remaining the same, the force of attraction or repulsion between two electrified spheres is directly as the product of the quantities of electricity with which they are charged.*

These laws were established by Coulomb, by means of the torsion balance used in determining the laws of magnetic attractions and repulsions (718), modified in accordance with the requirements of the case. The wire, on the torsion of which the method depends, is so fine that a foot weighs only $\frac{1}{10}$ of a grain. At its lower extremity there is a fine shellac rod, *np* (fig. 714), at one end of which is a small gilt pith ball, *n*. Instead of the vertical magnetic needle there is a glass rod, *z*, which passes through the aperture *r*, and is terminated by a gilt pith ball, *m*. The scale *oc* is fixed round the sides of

the vessel, and during the experiment the ball m is opposite the zero point o . The torsion head consists of a small graduated disc, e , movable independently of the tube d , and of a fixed index a , which shows by how many degrees the disc is turned. In the centre of the disc there is a small button, t , to which is fixed the wire which supports np .

i. The torsion head is turned until the zero point is opposite the index, and the tube d is turned until the ball n is opposite zero of the graduated circle; the ball m is in the same position, and thus just touches n . The knob m is then removed and electrified, and replaced in the apparatus, through the aperture r . As soon as the electrified knob m touches n , the latter becomes electrified, and is repelled, and after a few oscillations remains at rest at such a distance that the moment of the force of repulsion is equal to the moment of torsion. In a special experiment Coulomb found the angle of torsion between the two to be 36° ; and as the torsional couple is proportional to the angle of torsion, this angle represents the repulsive force between m and n . In order to reduce the angle to 18° it was necessary to turn the disc through 126° . The wire was twisted 126° in the direction of the arrow at its upper extremity, and

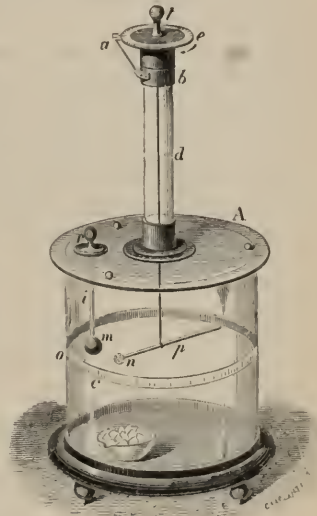

Fig. 714

18° in the opposite direction at its lower extremity, and hence there was a total torsion of 144° . On turning the torsion head in the same direction until the angle of deviation was $8\frac{1}{2}^\circ$, 567° of torsion was necessary. Hence the whole torsion was $575\frac{1}{2}^\circ$. Without sensible error these angles of deviation may be taken at 36° , 18° , and 9° ; and on comparing them with the corresponding angles of torsion, 36° , 144° , and 576° , we see that while the first are as $1 : \frac{1}{2} : \frac{1}{4}$, the latter are as $1 : 4 : 16$; that is, that for a distance $\frac{1}{2}$ as great the repulsion is 4 times as great, and that for a distance $\frac{1}{4}$ as great it is 16 times as great.

In experiments with this apparatus the air must be thoroughly dry, in order to diminish, as far as possible, loss of electricity. This result is effected by placing in the glass cylinder a dish containing calcium chloride.

The experiments by which the law of attraction is proved are made in much the same manner, but the two balls are charged with opposite electricities. A certain quantity of electricity is imparted to the movable ball, by means of an insulated pin, and the torsion head moved until there is a certain angle below. A charge of electricity of the opposite kind is then imparted to the fixed ball. The two balls tend to move towards each other, but are prevented by the torsion of the wire, and the movable ball remains at a distance at which there is equilibrium between the force of attraction, which draws the balls together, and that of torsion, which tends to separate them. The torsion head is then turned to a greater extent, by which more torsion

and a greater angle between the two balls are produced. And it is from the relation which exists between the angle of deflection on the one hand and the angle which expresses the force of torsion on the other, that the law of attraction has been deduced.

In the above it has been assumed that the distances between the fixed and movable balls are proportional to the angles. This is only true when the angles are small; with angles so large as 36° it is far from being so, and in such cases the chords must be substituted for arcs of the circle. In the experiment described above, the general principle only which is involved in the use of Coulomb's torsion balance is illustrated.

ii. To prove the second law let a charge be imparted to m ; n being in contact with it becomes charged, and is repelled to a certain distance. The angle of deflection being noted, let the ball m be touched by an insulated but unelectrified ball of exactly the same size. If in this way half the charge on one of the balls is removed, it will be found that the amount of torsion necessary to maintain the balls at their original angular distance is half what it was before.

The two laws are included in the formula $F = \frac{ee'}{d^2}$, where F is the force, e and e' the quantities of electricity on the surfaces of two spheres, and d the distance between their centres. If e and e' are of opposite sign, the action is one of attraction, while if they are the same it is a repulsive action.

Coulomb also established the law by the method of oscillations which is particularly applicable to the case of attraction, as there are difficulties in experimenting with the torsion balance in this case. A suitable apparatus

for this purpose consists of an insulated metal sphere (fig. 715), and at a little distance a short thin rod of shellac hung by a silk thread and with a disc of metal foil at one end, the whole being enclosed in a glass cylinder, which rests on an insulating plate.

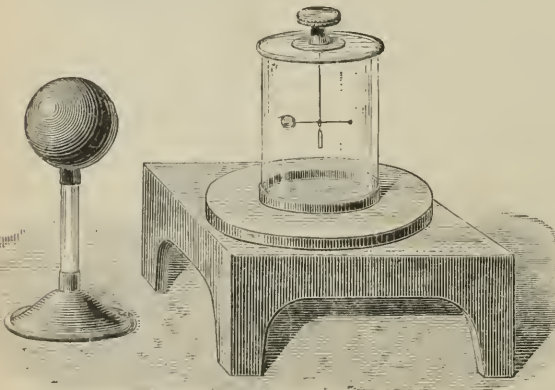

Fig. 715

If now the disc is charged with the opposite electricity to that of the sphere, and is removed from its position of equilibrium, it will make a series of oscillations. It can be proved that the charge on the sphere acts as if it were concentrated at the centre, and if the needle is short as compared with its distance from the sphere, the distance at which the force acts will be very nearly that from the centre of the sphere to the thread of suspension. The pendulum law (56) is thus applicable to the vibrations of the

needle, so that if t is the time of a complete vibration, $t = 2\pi\sqrt{\frac{I}{FL}}$, where I is the moment of inertia (89A) of the needle, L its length, and F the force. Now, all other things being the same, it is found that when the sphere is placed at varying distances, d and d_1 , the times of oscillations, t and t_1 , vary, and therefore the force varies, and the relation is established that $F : F_1 = d_1^2 : d^2$.

The most decisive proof of the inverse-square law of electric action between two charged points is derived from the fact that in the case of a conductor with a free charge of electricity the charge is exclusively on the surface, and that there is no electric force in the interior. Cavendish showed that with any other law of force this would not be so.

754. **Distribution of electricity. No charge inside a conductor.**—When an insulated conductor is charged with electricity, the charge occupies the surface of the conductor only. This result may be established by the following experiments:—

i. Let there be two insulated metal spheres of the same size, one hollow and the other solid, and let one of them receive a charge of either positive or negative electricity. When the two are brought into contact and then separated, and each in succession is allowed to touch the cap of an uncharged electroscope, the leaves diverge to the same extent for the hollow and solid spheres—a result which shows that the charge is equally divided between the spheres, and that the distribution depends upon the surface and not upon the mass of a conductor.

ii. A thin hollow copper sphere provided with an aperture of about an inch in diameter (fig. 716), and placed on an insulating support, is charged in the interior with electricity. When the *carrier* or *proof plane* (a small disc of copper-foil at the end of a slender glass or shellac rod) is applied to the interior, and is then brought near an electroscope, no electric indications are produced. But if the proof plane is applied to the electroscope after having been in contact with the exterior, a considerable divergence ensues.

The experiment may be made with a deep hollow metal vessel like that of fig. 732. When the cylinder is charged, no electricity will be found on the inside except near the upper edges.

The action of the proof plane as a measure of the quantity of electricity is as follows:—When it touches any surface the proof plane becomes confounded with the element touched: it takes in some sense its place relatively to the electricity, or, rather, it becomes itself the element on which the electricity is diffused. Thus when the proof plane is removed from contact we have in effect cut away from the surface an element of the same thickness and the same extent



Fig. 716

as its own, and have transferred it to the balance without its losing any of the electricity which covered it.

iii. In fig. 717, A is a brass globe fixed on an insulating support, and B and C are brass hemispheres, each separately insulated and arranged on a base board on which they can slide so as to form a sphere entirely enveloping A without touching it. There is a small aperture in C through which a copper wire *a*, provided with an insulating handle *b*, can be passed to make electric contact between the inner and outer spheres. Let A be charged, B and C be brought together, and the wire *a* inserted. The electricity on A is now free to pass to the enveloping hemispheres, and their electric condition is tested, after separation from each other and from A, by proof plane and electro-scope. It is found that A is entirely free from charge, the whole of the charge having passed to the hemispheres. This

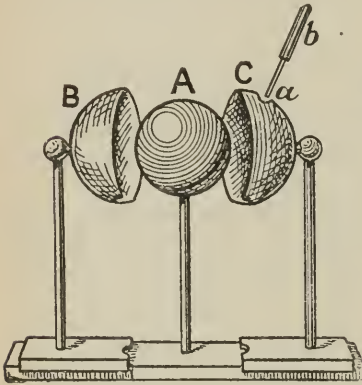

Fig. 717

experiment was first made by Cavendish, but the apparatus is commonly known as Biot's.

Another form of apparatus to illustrate the same fact is represented in fig. 718, in which A is a hollow brass hemisphere resting on a support of ebonite, and is electrified by being flapped with catskin; a similar hemisphere, B, provided with a glass handle, is placed over it. By means of a metal spring with an ebonite button, E, the outer and inner hemispheres may be brought into contact with each other. On afterwards removing B, and examining the two hemispheres, we find all the electricity on B.

iv. The distribution of electricity on the surface may also be shown by means of the following apparatus:—It consists of a metal cylinder on insulating supports, on which is fixed a long strip of tinfoil which can be rolled up by means of a small insulating handle (fig. 719). A quadrant electro-scope (748) is fitted in metallic communication with the cylinder. When the strip is rolled up, a charge is imparted to the cylinder, by which a certain divergence is produced. On unrolling the tinfoil this divergence gradually diminishes, and increases as it is again rolled up. The quantity of electricity remaining the same, the electric charge, on each unit of surface, is therefore less as the surface is greater.

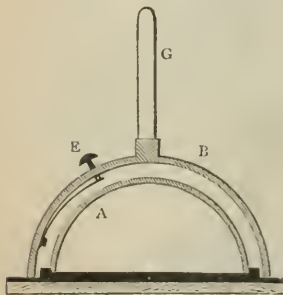

Fig. 718

v. The following ingenious experiment by Faraday further illustrates this law:—A metal ring is fitted on an insulating support, and a conical gauze bag, such as is used for catching butterflies, is fitted to it (fig. 720).

By means of a silk thread, the bag can be drawn inside out. After

electrifying the bag, it is seen by means of a proof plane that the electricity is on the exterior; but if the positions are reversed by drawing the bag inside out, so that the interior has now become the exterior, the electricity will still be found on the exterior.

The property of electricity, of accumulating on the outside of bodies, is ascribed to the repulsion which the particles exert on each other. Electricity tends constantly to pass to the surface of bodies, whence it continually tends to escape, but is prevented by the resistance of the feebly conducting atmosphere.

To the statement that electricity resides on the surface of bodies, two exceptions may be noted. When a steady current flows through a wire

the flow takes place throughout the whole mass of the conductor. Also a body placed inside another may, if insulated from it, receive charges of

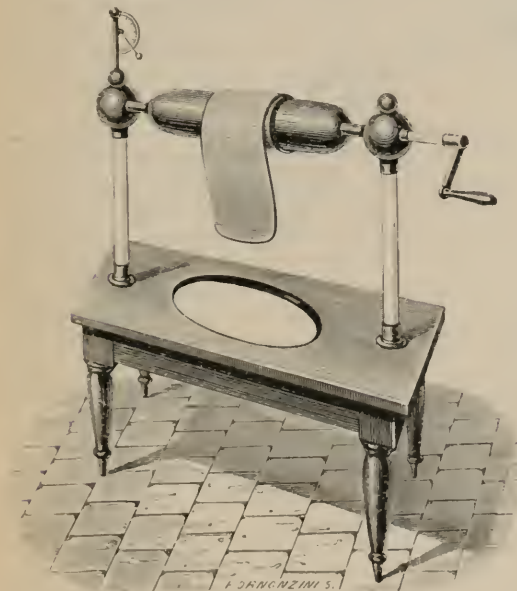

Fig. 719



Fig. 720

electricity. On this depends the possibility of electric experiments in ordinary rooms. Also the inside of a hollow conductor may receive an induced charge (762).

755. Electric density.—On a metal sphere the distribution of the electricity is everywhere the same, simply from its symmetry. This can be demonstrated by means of the proof plane and electroscope. A metal sphere placed on an insulating support is electrified, and touched at different parts of its surface with the proof plane, which each time is applied to the cap of the electroscope. As the divergence observed is in all cases sensibly the same, it is concluded that the proof plane each time receives the same quantity of electricity. In the case of an elongated ellipsoid (fig. 721) it is found that the distribution of electricity is different at different points of the surface. The electricity accumulates at the most acute points. This

is demonstrated by successively touching the ellipsoid at different parts with the proof plane, and then bringing this to the electroscope. It is found that the greatest deflection is produced when the proof plane has been in contact with the point a , and the least by contact with the middle space e .

The *electric density* at any part of a surface is the term used to express the quantity of electricity per unit area at that part of the surface. If S represents the surface in square centimetres, and Q the quantity of electricity on that surface in terms of the unit already defined (752), then, assuming

that the electricity is equally distributed, as on a sphere, its electric density is equal to $\frac{Q}{S}$.

If the distribution varies rapidly the electric density at any particular spot is equal to the quantity which would be present on a square centimetre embracing that spot, if the

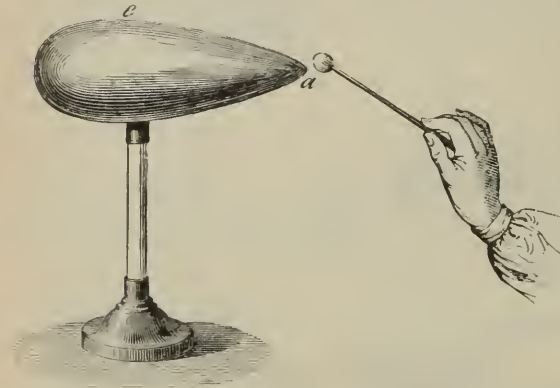

Fig. 721

distribution were uniform throughout the square centimetre and the same as at the spot in question. On an insulated cylinder, terminated by two hemispheres, the density of the electric layer at the ends is greater than in the middle. On a circular disc the density is greatest at the edges.

756. **Force outside an electrified body.**—The force F which a sphere, charged with a quantity of electricity Q , exerts on unit charge at a distance d from its centre, is $\frac{Q}{d^2}$; this is equal to $\frac{\sigma S}{d^2}$, if S is the area of the sphere, and σ the density of electricity on its surface. Now the area of the sphere is $4\pi R^2$; and if the distance d is equal to the radius R , then the force outside the surface but close to it = $\frac{4\pi\sigma R^2}{R^2} = 4\pi\sigma$.

It may be shown in like manner that the force due to *any* closed conductor on unit charge, placed just outside it, is $4\pi\sigma$.

On an insulated conductor, where the electricity is in equilibrium, a particle of electricity will have no tendency to move along the surface, for otherwise there would be no equilibrium. But the electricity does exert a pressure on the external non-conducting medium, which is always directed outwards, and is called the *electrostatic pressure* or *electric tension*, and represents the endeavour of the charge of electricity to violently break through the insulation of the dielectric. The amount of this pressure is $2\pi\sigma^2$ for unit area, σ being the electric density at the point considered. The effect of this on a soap-bubble, for instance, if electrified with either kind of

electricity, is to enlarge it. In any case the electrification constitutes a deduction from the amount of atmospheric pressure which the body experiences when unelectrified.

The terms *electric density* and *electrostatic pressure* are often confounded. The latter ought rather to be restricted, as Maxwell proposed, to express the state of stress or pressure exerted upon a dielectric in the neighbourhood of an electrified body producing a strain which, if continually increased, tends to disruptive discharge. It varies as the square of the electric density, and is equal to $2\pi\sigma^2$ per unit area. The *electric force* just outside a charged conductor—that is, the mechanical force on the unit charge—is, as we have seen above, $4\pi\sigma$, and varies as the simple power of the electric density. Electrostatic pressure may thus be compared to the strain on a rope which supports a weight; and the dielectric medium which can support a certain tension and no more is said to have a certain *electric strength* in the same sense as a rope which bears a certain weight without breaking is said to have a certain strength.

757. **Potential.**—If one end of a wire is connected to the cap of a gold-leaf electroscope, and the other end, held in insulating tongs, is allowed to touch the surface of the elongated conductor (fig. 721), we find that whatever part is touched the divergence of the leaves is the same. It has been already seen that the electric density is greatest at the pointed end, and varies as the curvature of the surface. It has also been seen that when the sphere (fig. 716) is charged, the charge resides on the surface, and there is no electricity inside. But whether the wire connected with the electroscope touches the inside or outside of the hollow sphere, the indication of the electroscope is the same. It is clear, therefore, that there is some property of the charged conductor which is the same at all parts of its surface, however unequally the electricity may be distributed on that surface. This property is called *electric potential*. Two conductors, A and B, have the same potential when, on connection being made between them by a wire, no electricity passes from the one to the other. If positive electricity passes from A to B, A is at a higher potential than B. The earth and all things in conducting connection with it are said to be at zero potential. If A is positively charged and is earth-connected, there is a flow of positive electricity from it to the earth; it must therefore have been at a higher potential than the earth, or at a positive potential. On the other hand, if it is negatively charged, it is at a lower potential than the earth, or at a negative potential, because, if it were earthed, positive electricity would flow from the earth to it. When electricity, without qualification as to sign, is spoken of, positive electricity is always meant.

Potential is analogous to *level* in mechanics and hydrostatics. As water only flows from places at a higher to places at a lower level, so electricity only flows from places at a higher to places at a lower potential. If two water tanks are connected by a pipe, there will be a flow of water from the tank in which the water level is higher to that in which it is lower, and the flow will continue until the level is the same in both. The flow does not depend upon the quantities of water in the tanks. So when two conductors are charged with electricity, there will only be a flow of electricity from one to the other when there is a difference of potential between them, however

different the charges may be. The cause of flow of water is, of course, hydrostatic pressure, and this is proportional to difference of level. If two vessels containing air or steam or any other gaseous substance, at different pressures, are joined by a pipe with a stopcock, the difference in pressure will cause a flow of gas from one to the other when the stopcock is opened, and the flow will take place from the vessel of higher to that of lower pressure. Quantity of gas is here the analogue of quantity of (positive) electricity, and difference of pressure the analogue of difference of potential. Electric engineers constantly refer to the difference of potential which causes a flow of electricity as *electric pressure*. It must be carefully distinguished from *electrostatic pressure* (756).

We cannot speak of potential in the abstract, any more than we can speak of any particular level without at least some tacit reference to a standard of level. Thus, if we say that such and such a place is 300 feet high, we usually imply that this is the height above sea level. So, too, we refer the longitude of a place to some definite meridian, such as that of Greenwich, either expressly or by implication. In like manner we cannot speak of the potential at a point without at least an implied reference to a standard of potential. The standard is usually the earth, which is taken as being at zero potential, or the same as the potential at an infinite distance. If we speak of the potential at a given point, the difference between the potential at this point and the earth is meant.

The relation between *quantity of electricity* and *electric potential* may be further illustrated by reference to certain well-known thermal phenomena. In the interchange of heat between bodies of different temperatures the final result is that heat passes only from bodies of higher to bodies of lower temperature. So also electricity passes only from bodies of higher to bodies of lower potential. Potential is as regards electricity what *temperature* is as regards *heat*, and might indeed be called *electric temperature*. We may have a small quantity of heat at a high temperature; thus a short thin wire heated to incandescence has a far higher heat potential, or temperature, than a bucket of hot water, but the latter will possess a much larger quantity of heat. The quantity of electricity in a flash of lightning is small, but the potential is very high.

758. Measure of potential.—We have already seen, that in order to lift a certain mass against the attraction of gravity (60-62) there must be a definite expenditure of work, and the equivalent of this work is met with in the energy which the lifted mass retains, or what is called the potential energy of position.

Let us now suppose that we have a large insulated conductor charged with positive electricity, and that, at a distance which is very great in comparison with the size of the sphere, there is a small insulated sphere charged with the same kind of electricity. If we move the small sphere, which we will suppose to have unit charge (752), towards the conductor, we must do a certain amount of work upon it to overcome the repulsion between the two charges. The potential of the conductor is numerically equal to this work, if the small sphere is moved from an infinite distance, that is, from a place where the potential is zero, close up to the conductor. And generally, if V is the potential at any point, either on a conductor or in a dielectric,

V units of work (ergs) would have to be done against electric forces to bring the unit charge from an infinite distance to that point.

If in the above case the sphere was charged with negative electricity, then instead of its being needful to do work in order to bring a unit of positive electricity towards it, work would be done by electric attraction, and the potential of the point near the charged sphere would thus be negative. The potential at any point may also be said to be the work done against electric force, in moving unit charge of negative electricity from that point to an infinite distance.

The amount of work required to move the unit of positive electricity against electric force from any one position to any other, is equal to the excess of the electric potential of the second position over the electric potential of the first. This is, in effect, the same as has been said above, for at an infinite distance the potential is zero. Here it is immaterial along what path the electricity is moved, whether by the shortest one or not; just as in the analogous case of moving a body against gravity the work done only depends on the initial and final position of the body moved.

It may be proved that the potential at a point A (fig. 722), distant r from a charge, q , of positive electricity, is $\frac{q}{r}$. That is, $\frac{q}{r}$

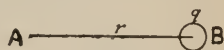

Fig. 722

represents the work which must be done upon a unit of positive electricity to bring it from an infinite distance to A against the repulsive force of a charge q situated at B.

To determine the potential at A due to several independent causes, we must write down the value of the potential due to each separate cause, and take the algebraic sum of these to represent the actual potential. If there are three charges, $+q_1, -q_2, +q_3$, situated at the points B, C, D (fig. 723), distant respectively r_1, r_2, r_3 from A, the potential at A is

$$\frac{q_1}{r_1} - \frac{q_2}{r_2} + \frac{q_3}{r_3}$$

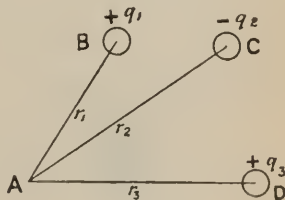

Fig. 723

It must be noted that although potential is measured in terms of work, it is not of the same nature or dimensions as work;

potential is equal to work done upon a definite quantity of electricity, or $V = \frac{\text{work}}{\text{electric charge}}$, or $QV = W$, if Q = quantity of electricity and W = work.

Now the dimensions of work are (63) ML^2/T^2 , and since $F = \frac{ee'}{d^2}$ (753), the dimensions of the square of an electric charge are equal to (the dimensions of) Fd^2 , or are $\frac{ML}{T^2} \times L^2$; therefore the dimensions of electric charge are

$$\frac{M^{\frac{1}{2}}L^{\frac{3}{2}}}{T}, \text{ and of potential, } \frac{ML^2}{T^2} \div \frac{M^{\frac{1}{2}}L^{\frac{3}{2}}}{T} = \frac{M^{\frac{1}{2}}L^{\frac{1}{2}}}{T}. \text{ (See also art. 1000.)}$$

Frequently the unit charge is assumed, and we speak of the potential as so many ergs, but it must be remembered that this is accurate only in the sense in which it is accurate to speak of a velocity of so many miles [*per hour* being understood], or a pressure of so many pounds [*per square inch* being understood].

759. **Electric field. Lines of electric force.**—A region in which force is exercised is called a *field of force*. The space round the earth is a field of gravitational force due to the earth's attraction. The lines along which force is exercised are called *lines of force*, and the field is uniform when the lines of force are parallel to each other and uniformly spaced. The earth's gravitational field of force is uniform over a given small area.

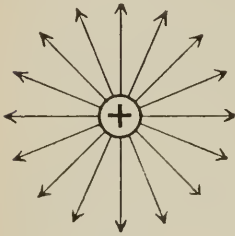

Fig. 724

An electric field is a region in which electric force is exerted. Electric force acts upon electric charges as mechanical or gravitational force acts upon matter. Mechanical force has no action upon a charge of electricity, any more than electric force acts upon matter. Let a sphere be charged with a quantity Q of positive electricity. The electric force at any distance r from its centre is $\frac{Q}{r^2}$; thus the force rapidly falls off as the distance from the sphere increases.

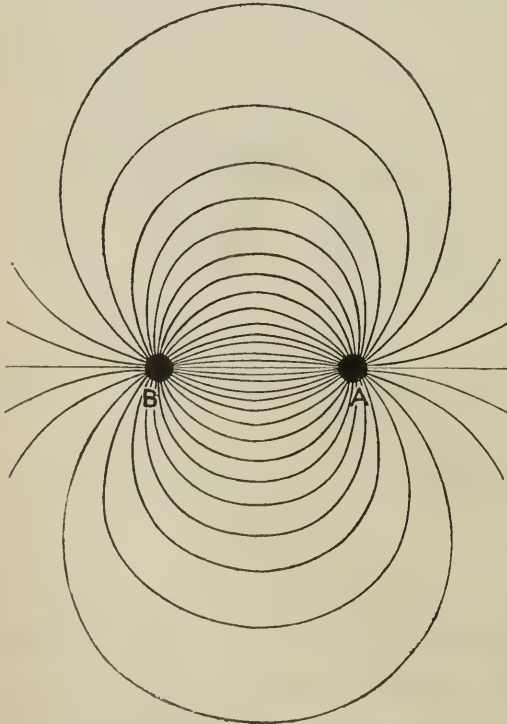

Fig. 725

shown in fig. 725, and fig. 726 illustrates the distribution of the lines when the charges are both positive or both negative.

The lines of force due to a positively charged sphere are straight lines radiating as from the centre of the sphere. They start, however, not from the centre but from the surface, are directed outwards, and are uniformly spaced (fig. 724). If the charge were doubled, the number of lines would be doubled. If the charge is negative the arrows will be directed towards the sphere, since the direction of a line of force is the direction in which a positive charge moves along it. The lines of force in the field due to two spheres a short distance apart equally charged, one with positive and the other with negative electricity, are

The lines of electric force may be made visible in the dark by placing two small balls at a distance from each other in conducting communication

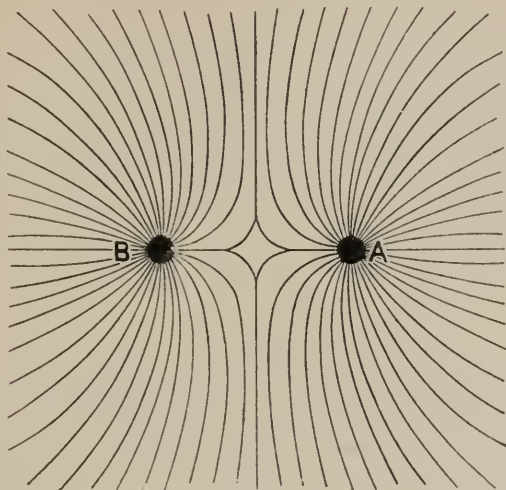

Fig. 726

with an electric machine at work, and then sifting lycopodium powder through a fine sieve while the space is at the same time illuminated by the lime or the electric light. They may also be shown experimentally by the apparatus represented in fig. 727 : two stout wires terminated in small knobs are fitted to the sides of a flat glass dish in which is placed turpentine with quinine sulphate uniformly diffused in it ; when the wires are connected with the electrodes of an electric machine (776), which is very slowly worked, the white crystals arrange themselves in lines which are the lines of force of the field in question.



Fig. 727

An *equipotential surface* is a surface such that the potential is the same at all parts of it ; and the trace of an equipotential surface on a plane is an *equipotential line*. If a small test charge is moved along an equipotential surface no work is done by or against electric force. Lines of force are everywhere perpendicular to equipotential surfaces. In the case of an insulated electrified sphere the successive equipotential surfaces are spherical shells of gradually increasing radii. Fig. 728 illustrates the case of a sphere of radius 1 cm., with a charge numerically equal to 10 units. The potential is equal to 10, and the equipotential circles (portions of them only are shown in the figure) are drawn so that the difference of potential between successive surfaces is unity. The fall of potential is very rapid near the sphere, but falls off slowly at distances exceeding 5 cm. from the centre. At this distance the potential is 2, at 10 cm. it is 1, and at a distance of a metre from A the potential is only $\frac{1}{10}$ (758).

If the force in a field has everywhere the same direction, the equipotential surfaces are parallel planes, the lines of force are parallel, and we have a *uniform field*.

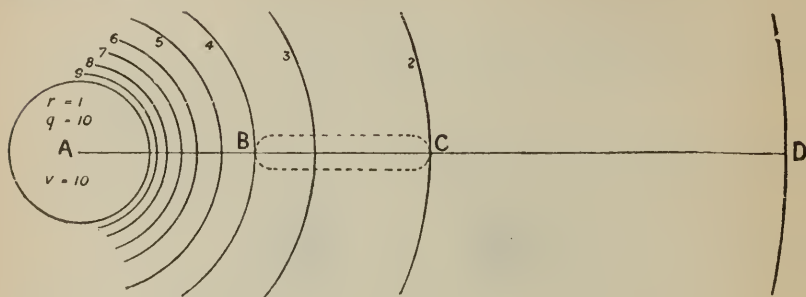

Fig. 728

The case we have selected for illustrating the subject of equipotential lines is the simplest that could be chosen. But, bearing in mind that an equipotential line cuts lines of force at right angles, it is easy to trace the equipotential lines in less simple cases—such as that of the ellipsoidal conductor in fig. 721—when the lines of force in the field have been drawn, or of the similarly and dissimilarly charged spheres of figs. 725 and 726. The surface of a conductor is always an equipotential surface.

760. Electric capacity.—When a conductor, away from the neighbourhood of other conductors, is charged with positive electricity the potential rises as the charge increases, and is directly proportional to the charge. If two conductors, not near each other, are charged with equal quantities of positive electricity, they are not raised to the same potential unless they have one property in common, which is called *electric* or *electrostatic capacity*. The capacity of a conductor depends upon its size and shape, and upon its position with regard to other conductors; it depends also upon the nature of the surrounding medium. The electrostatic capacity of a conductor is measured by, and is numerically equal to, the quantity of electricity which must be communicated to the conductor to raise by unity its potential above the potential of surrounding conductors. Thus, if C represents the capacity of a conductor, Q the quantity of electricity with which it is charged, and V the difference between its potential and that of neighbouring bodies, the relation $Q = CV$ holds.

It has already been stated (758) that the potential at a distance d from the centre of a sphere charged with a quantity Q of electricity is Q/d ; if $d = r$, the radius of the sphere, the potential (which is now that of the sphere itself) is Q/r . Comparing this with the formula above, we see that the capacity of a sphere surrounded by air and away from other conductors is equal to its radius.

Electrostatic capacity is analogous to the capacity of a liquid measure. Imagine a litre jar or cylinder graduated in cubic centimetres, with the graduation 1000 some little distance from the top. The capacity of this vessel is said to be 1 litre, being measured by the quantity of liquid which

must be poured into it to fill it up to the mark 1000. In the same way the electrostatic capacity of a conductor is measured by the quantity of electricity which must be communicated to the conductor to raise it from zero to unit potential, or more generally to raise its potential by unity, any conductors which are near to it being supposed to be at zero potential.

There is an analogy between heat and electricity, as regards capacity, but there are also important differences; thus the capacity of a body for heat is influenced by the temperature (463), being generally greater at higher temperatures, while the capacity of a body for electricity does not depend on the potential. Again, the thermal capacity depends solely on the mass of a body, and in bodies of the same material and shape is proportional to the cube of homologous dimensions; the capacity for electricity is directly proportional to such dimensions, and not to the weight or volume. Thermal capacity is proportional to a specific coefficient, which varies with the material, but is independent of its shape; while electric capacity varies with the shape of a body, but not with its material, provided the electricity can move freely upon it. Thermal capacity is unaffected by the proximity of other bodies, while the electric capacity depends on the position and shape of all the adjacent conductors.

If we have a series of bodies at a considerable distance from each other, whose capacities and potentials are respectively $c, c', c'',$ &c., and $v, v', v'',$ &c., then, if they are all connected by fine wires of no capacity, they all instantly acquire the same potential V , which is determined by the equation

$$V = \frac{cv + c'v' + c''v''}{c + c' + c''}.$$

The analogy of this to the equalisation of temperature which takes place when bodies at different temperatures are mixed together is directly apparent. It may be further illustrated by supposing a series of tubes of different diameters, and connected by very narrow tubes, in which are stopcocks to cut off communication. If, while in this state, water is poured into the tubes to different heights above the common level, it will be manifest that they will hold very various quantities of water. If, however, the stopcocks are opened, the tubes will still contain quantities of water proportional to their capacities, but the level or potential in all will be the same.

761. Action of points.—Since the electric density at any part of the surface of a conductor increases with the curvature of the part, the density at a fine point in connection with a conductor must tend to become infinitely great; but the greater the density the greater will be the tendency of electricity to overcome the resistance of the air, and escape, for the electrostatic pressure is proportional to the square of the density (756). If the hand is brought near a point on a conductor connected with an electric machine in action, a slight wind is felt; and if the disengagement of electricity takes place in the dark a luminous brush is seen. If an electrified conductor is to retain its electricity, all sharp points and edges must be avoided; on the other hand, to facilitate the outflow of electricity in apparatus and experiments, frequent use is made of this action of points. A flame acts like a very fine point in diffusing electricity. For experiments illustrating the action of points, see art. 780.

CHAPTER III

ELECTROSTATIC INDUCTION OR INFLUENCE. ELECTRIC MACHINES

762. **Electrostatic induction.**—When a conductor is brought into the electric field produced by a charged body it becomes thereby electrified with a positive charge at one end and a negative charge at the other, the two charges being separated by a region in which there is no electrification. The process is called *electrostatic induction* or *influence*, the electrification is *induced*, and the charged body which produces the field is the *inducing body*. The elementary facts of electrostatic induction may be demonstrated by the apparatus illustrated in fig. 729. A is the charged body which produces the field ; it is represented here

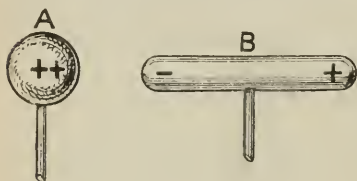

Fig. 729

as a sphere charged positively, but in practice may be an excited glass rod. B is an insulated uncharged cylinder ; it becomes electrified by induction, and we may test the distribution of electricity on it by the proof plane and electroscope. For this purpose let the proof plane, after touching the remote end of B, be brought to the cap of an electroscope. The leaves diverge, and with positive electricity, as is rendered evident by the fact that the divergence increases when a small charge from an excited glass rod is applied to the cap. When the charge at the near end of B is similarly tested, it is found to be negative. Between the two ends of B is a neutral region, from which no electricity can be carried away by the proof plane. That the charges on B are equal to each other is shown by the fact that when the cylinder is removed from the field of A it is found to be without charge. The neutral region on B is generally on the side of it nearer to A, for though the negative and positive induced charges are equal, they are unequally distributed, that nearer to A being the denser, and therefore occupying less surface.

If, while B is under induction, any point of it is momentarily touched with the finger, positive electricity will flow from it to the earth, reducing it to zero potential. This must be so, since B, being in the field of A, is at a positive potential. But, although, after being touched, B is at zero potential, it still retains a negative charge at the end near A. This result follows whatever part of it is touched, since connecting one part to earth means connecting every other part to earth. If now the sphere and cylinder are separated

the negative charge at the end of B spreads over its surface, and the potential of the cylinder becomes negative.

The experiments described above may easily be made with a gold-leaf electroscope and a charged body, glass or sealing-wax. Fig. 730 illustrates the case when an excited rod is held at a little distance above the cap of the electroscope.

The conductor, which takes the place of the cylinder B in fig. 729, here consists of the knob, rod, and leaves of the electroscope. The cap acquires a positive and the leaves a negative charge, the whole conductor being at a negative potential. The leaves diverge because their potential is different from (lower than) that of the earth (787), the angle of divergence being a rough measure of the difference. When C is touched the potential rises from a negative value to zero, and the leaves collapse, although a positive charge still resides on the cap.

This charge cannot be got rid of so long as A remains; but when A is removed, the potential of C—which, notwithstanding the positive charge, was kept down at zero by the influence of the negatively charged rod—at once rises, the electricity spreads over the whole conductor, and the leaves diverge with a positive charge.

Thus a body can be charged with electricity by induction as well as by conduction. But, in the latter case, the charging body loses part of its electricity, which remains unchanged in the former case. The electricity imparted by conduction is of the same kind as that of the electrified body, while that excited by induction is of the opposite kind. To impart electricity by conduction, the body must be quite insulated; while in the case of induction it must be in connection with the earth—at all events momentarily.

A body electrified by induction acts in turn on bodies placed near it, separating the two electricities in a manner shown by the signs on the cylinder B (fig. 729).

What has here been said has reference to the inductive action exerted on good conductors. Bad conductors are not so easily acted upon by induction, owing to the great resistance they present to the circulation of electricity; but, when once charged, their electric state is more permanent.

This is analogous to what is met with in magnetism; a magnet instantaneously magnetises a piece of soft iron, but the magnetisation is only temporary, and depends on the continuance of the action of the magnet; a magnet magnetises steel with far greater difficulty, but this magnetisation is permanent.

The attraction of a pith-ball pendulum (fig. 705) is explained by induction. Let M be a charged body and N a pith ball (fig. 731).



Fig. 730

If the pendulum is suspended by an insulating thread, such as dry silk, M, acting inductively on N, attracts the negative and repels the positive electricity, so that the maxima of density are respectively at the points a and b . Now a is nearer c than b is; and, since attractions and repulsions are inversely as the square of the distance, the attraction between a and c is greater than the repulsion between b and c ; and, therefore, N will be attracted to M by a force equal to the excess of the attractive over the repulsive force.

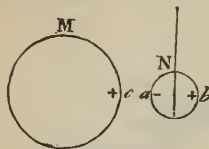

Fig. 731

If the thread is not an insulator, then the electricity of the same kind as that of the inducing body passes to earth through the thread and the supports, and the attraction is stronger than in the previous case.

763. **Potential of a conductor under induction independent of the sign or density of the electrification.**—We have seen in the last article that it is possible for a conductor to have opposite charges at its two ends although all parts of it must be at the same potential. To explain the difficulty which here seems to present itself, it will be convenient to assume some numerical values. Suppose the inducing body to be the sphere illustrated in fig. 728, with charge = 10, radius = 1, and consequently potential = 10. Then the sphere, with no other conductors are near, produces an electric field, the lines of force in which are radial lines, and the equipotential surfaces as shown in the figure. Suppose an insulated cylinder to be placed in the position BC, so that B is at the place where the potential is 4, and C at the place where the potential is 2. We are then connecting by a conductor two places of different potential, the result of which is that there is a flow of electricity from B to C in order that the potentials at B and C may be equalised: B loses electricity and becomes negatively charged, C gains and becomes positive, the opposite charges being necessarily equal to each other, and the whole cylinder assumes a potential intermediate between 4 and 2, say 3. When the cylinder is earthed the positive charge at C disappears, the potential falls from 3 to zero, and the negative charge at B increases. That this is so will be clear from the consideration that when BC is introduced into the field of A there is a displacement of electricity from B to C, to an extent depending on the difference of potential between B and C, that is, being the greater the lower the potential of C. Thus the loss of electricity at B (that is, its negative charge) must increase when B is lowered from a potential 3 to zero.

These experiments teach us to distinguish between the potential which a body has in virtue of its own charge, and that which it has in consequence of its position in the electric field due to some other conductor. These may be called respectively the *free* and *induced potentials* of the body. The actual potential is due to their algebraic sum. Thus in the example above: at B the induced potential is 4, but the negative charge there would, if it were free and uninfluenced, give rise to a *negative* potential; hence the actual potential at B is not 4, but something less than 4. Similarly, at the end C the induced potential is 2, but there is an additional potential due to the positive charge, so that the actual potential is not 2, but something more than 2.

764. **Faraday's experiments.**—The following experiments of Faraday, which are often known as 'the ice-pail experiments,' from the vessels with which they were originally made, are excellent illustrations of the operation of induction, and are of great theoretical importance :—

A carefully insulated metal cylinder, A (fig. 732), is connected by a wire with an electroscope E, at some distance. When an insulated brass ball C, charged with positive electricity, is lowered into the cylinder, the leaves of the electroscope diverge, and, as can be shown, with positive electricity, and the divergence increases until the ball has attained a certain depth, after which there is no further increase. The divergence now remains constant, whatever be the position of the ball, and when the inside and outside are tested with the proof plane they are found to be charged with negative and positive respectively. If the ball is withdrawn the leaves of the electroscope collapse, and there is no electrification on the cylinder; the quantities of negative and positive electricity developed on the two surfaces are accordingly equal to each other.

If now the ball, while still charged with positive electricity, is brought as before into the cylinder, and is allowed to touch the inside, there is no alteration, not even a momentary one, at the moment of contact, in the divergence of the leaves of the electroscope; but if the ball is withdrawn it will be found to be discharged, while the charge (positive) on the cylinder is entirely on the outside.

The positive charge on the ball produces a negative charge on the inside of the vessel, an equal positive charge spreading over the outside, the wire, and the electroscope. There is an electric field inside, the lines of force of which pass from the ball to the inner surface of the vessel. This internal field entirely disappears, when the ball touches the vessel, without any disturbance of the distribution or potential of the outside.

If, while the ball charged with positive electricity is inside the cylinder, the latter is momentarily put to earth, the gold leaves collapse, and the proof plane, if applied to the outside, removes no trace of electricity; the cylinder behaves towards all external bodies as if it were neutral. The internal surface is, however, charged with negative electricity equal to the positive charge of the ball, for all trace of electricity disappears if the ball is made to touch the side.

If the ball, after the cylinder has been momentarily connected to earth, is removed without having touched the sides, the negative passes to the outside and forms there a layer which is distributed as was the layer of positive electricity before the cylinder was connected with the ground. The cylinder is thus finally charged with a quantity of electricity equal and of opposite sign to that of the inducing body.

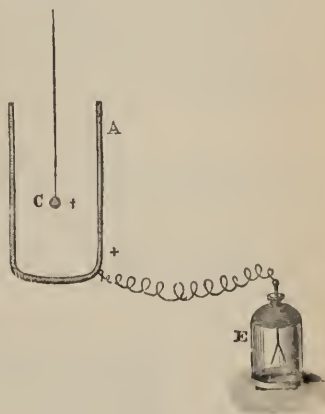

Fig. 732

Four such cylinders (fig. 733) are placed concentrically one within another; they are insulated from each other by discs of shellac, and the outer one is connected with the electroscope. On introducing the charged ball into the central cavity the leaves diverge just as if the intermediate ones did not exist. Each of these is charged with equal quantities of opposite electricities, all equal in value to that of the sphere. The internal charge of the cylinder is the same as if all the intermediate cylinders were suppressed, and the charge does not vary even when the intermediate ones are connected with each other or are touched by the electrified ball C.



Fig. 733

If, while C is in its original condition, the internal cylinder, 4, is connected with the ground, the leaves collapse, and the other cylinders are in the neutral state; the two layers which remain positive on C, and negative on the adjacent cylinder, are without action on an external point. If any other cylinder be thus treated the external ones are reduced to the neutral state.

With the aid of the cylinder (fig. 732) it is easy to demonstrate that by friction both electricities are produced at the same time, and in equal quantities (749). For if the flannel and sealing-wax in fig. 712 after being rubbed are placed simultaneously in the cylinder no divergence is produced, while if introduced separately they produce equal divergence but of opposite sign.

Whenever a charge of electricity exists there is somewhere an equivalent and corresponding charge of electricity of the opposite kind. This may seem inconsistent with the fact that an insulated sphere may have a charge of one kind of electricity. But it is to be remembered that this is in effect the case of a Leyden jar (786) in which the dielectric is the layer of air between the sphere and the sides of the room which form the outer coating.

765. **Faraday's chamber.**—Faraday constructed a cubical box of wood, each edge measuring 12 feet, which he covered with tinfoil and insulated by glass supports. This chamber could be charged to a high potential by an external electric machine, but a gold-leaf electroscope placed inside showed no effect. He says: 'I went into the cube and lived in it, using lighted candles, electrometers, and all other tests of electrical states. I could not find the least influence upon them or indication of anything particular given by them, though all the time the outside of the cube was powerfully charged and large sparks and brushes were darting off from every part of its outer surface.' Faraday thus showed that, however intense the field in which a hollow conductor is placed there is no electric force inside the conductor. This result also follows from the fact, experimentally established, that the potential is constant at all parts of the region inside a hollow conductor, and is the same as that of the conductor itself. For the difference of potential of two neighbouring points, A and B, is numerically equal to the work which must be done on the unit charge of elec-

tricity in order to move it from A to B. But the work is also equal to the mean electric force which opposes the transfer, multiplied by the distance between A and B; or, $V_1 - V_2 = Px$, where P is the mean force and x the distance. But in the inside of a conductor $V_1 = V_2$, and therefore $P = 0$.

If the outside surface of Faraday's chamber is connected by a wire to the cap of a gold-leaf electroscope, the latter is unaffected when substances such as glass and silk are rubbed together inside. The charges on the glass and silk are equal, and produce equal and opposite effects on the outside of the chamber. No change is produced when the rubber is thrown on the floor, for the positive is then on the glass, and the equal negative on the walls, floor, and ceiling of the chamber. If an electrophorus or electric machine of any kind is worked in the chamber, the electric field thereby produced is entirely confined to the inside; the electroscope outside is unaffected. Thus we learn that when electric experiments are made in a room of any kind, whether insulated or not, no electricity leaves the room. A conductor is *earthed* when it is connected with the walls or floor of the room, but the charge which escapes from such a conductor does not pass into the earth.

But if in the 'Faraday's chamber' experiments the silk after rubbing the glass is removed, for example through the window, the leaves of the external electroscope diverge with positive potential, the inside walls having a negative charge equal to the positive of the glass.

It is found that a hollow conductor made of wire with rather big meshes behaves with respect to electric charges as if it were of continuous metal. Such a conductor is often useful in electric experiments, as we are able to see what goes on inside it. Let A be such a cylinder made of brass wire and open at the bottom. It rests upon an insulating stool D, and inside it is a gold-leaf electroscope B suspended by silk ribbons. In accordance with what has been said, no external electrification produces any effect on the electroscope; the wire cylinder acts as an efficient screen and cuts off all electric action. Even when the cylinder is itself highly charged, the electroscope gives no indication. Now let the cap of

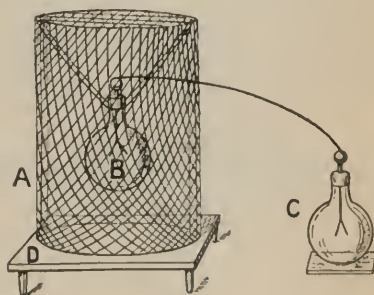

Fig. 734

the electroscope B be connected by a gutta-percha-covered copper wire to the cap of another electroscope, C, exactly like B, standing on the table, the wire passing through one of the meshes of the netting. When A is charged positively, the leaves of both electroscopes diverge; and since electricity has passed from B to C, B has a negative and C a positive charge. Let V be the potential of the cage; that of B will be somewhat lower, say V_1 , and the divergence of B's leaves indicates the difference $V - V_1$. The divergence of C's leaves indicates the difference of potential between it and the table on which it stands, namely V_1 . Thus the two electroscopes,

although at the same potential, do not generally show the same divergence. If C is earthed, the potential of B and C falls to zero; hence the leaves of C collapse, while those of B diverge more than before.

766. **Faraday's theory of induction.**—The experiments of Faraday on the part which the medium plays in inductive actions, with their subsequent mathematical expression, and development by Maxwell, have led to a profound alteration in the mode of interpreting electric phenomena.

Faraday regarded conductors as in a certain sense qualitatively different from non-conductors; the latter he called *dielectrics*, to express that they allow electric forces to act through them; electric forces cannot penetrate into the interior of conductors, but terminate at the surface just as light is stopped by an opaque body.

Faraday assumed that insulators or non-conductors consisted of a number of molecules, possibly spherical in shape, which are perfect conductors and are disseminated in, and separated from each other by, a non-conducting medium. When placed in an electric field, the inductive action may be taken to be that electrification is produced in the conducting molecules, positive on one face and negative on the opposite one, the molecules being thus arranged in polar chains; those faces of the molecules which are turned towards the inducing body having electricity of the opposite kind to that of the latter, while those which are turned away from it have electricity of the like kind. In the interior of the medium where successively the positive face of one molecule is presented to the negative of the next, the two electricities neutralise each other throughout, but when the non-conductor is bounded by conductors, and the boundaries of an electric field are always conductors, the free electrification is no longer neutralised, but constitutes the charge of electricity which is perceived. This is analogous to the action of a magnet on iron filings, where they acquire a polar arrangement along the direction of the lines of force; the polar chains in electrification representing the lines of electric force. This action Faraday called *dielectric polarisation*. We may add that

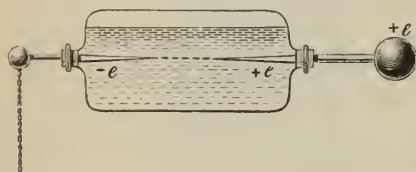

Fig. 735

the lines of electric force tend to contract in the direction of their length, and they repel each other at right angles thereto (700).

The following experiment was devised by Faraday to illustrate the *polarisation of the medium*, as he called it. He introduced small filaments of silk

into a vessel of turpentine (fig. 735), and, having placed two conductors in the liquid on opposite sides he charged one by connecting it with an electric machine at work, and placed the other in connection with the ground. The particles of silk immediately arranged themselves end to end, and adhered closely together, forming a continuous chain between the two sides. If the chain is broken it again forms, while when the electric action ceases the particles disperse. An experiment by Matteucci also supports Faraday's theory. He placed several thin plates of mica closely together, and provided those on the outside with metallic coatings. Having electrified the system, he removed the coatings by insulating handles, and on examining

the plates of mica successively, found that each was charged with positive electricity on one side and negative electricity on the other.

Kleiner extended this experiment by charging a condenser the insulator of which was mica, and determining the quantity of electricity by measuring the discharge. He then recharged the condenser to the same extent, split off films successively and discharged them by the same plates, and found thus that, allowing for unavoidable losses of insulation, the charge on each film was the same.

767. **Communication of electricity at a distance.**—In the experiment represented in fig. 729 the opposite electricities of the sphere and the cylinder tend to unite, but are prevented by the resistance of the air. If the electric density is increased, or if the distance of the bodies is diminished, the opposed electricities at length overcome this obstacle; they rush together and combine, producing a spark, accompanied by a sharp sound. The negative electricity separated on the cylinder being thus neutralised by the positive electricity of the charged body, a charge of positive electricity remains on the cylinder.

The striking distance varies with the difference of potential, the shape of the bodies, their conducting power, and with the resistance and pressure of the interposed medium.

768. **Plate electric machine.**—The first electric machine was invented by Otto von Guericke, the inventor also of the air-pump. It consisted of a sphere of sulphur, which was turned on an axis by means of the hand, while the other hand, pressing against it, served as a rubber. Resin was afterwards substituted for the sulphur, which, in turn, Hawksbee replaced by a glass cylinder. In all these cases the hand served as rubber; and Winckler, in 1740, first introduced cushions of horsehair, covered with silk, as rubbers. At the same time Bose collected electricity, disengaged by friction, on an insulated cylinder of tin plate. Lastly, Ramsden, in 1760, replaced the glass cylinder by a circular glass plate which was rubbed by cushions. The form which the machine has now is but a modification of Ramsden's original machine.

Between two wooden supports (fig. 736) a circular glass plate P is suspended by an axis passing through the centre, turned by means of a handle M. The plate revolves between two sets of *cushions* or *rubbers*, F, of leather or of silk, one set above the axis and one below, which, by means of screws, can be pressed as tightly against the glass as may be desired. The plate also passes between two brass rods, shaped like a horseshoe, and provided with a series of points on the sides towards the glass; these rods are fixed to larger metallic cylinders CC, which are together called the *prime conductor*. The latter are insulated by being supported on glass feet, and are connected with each other by a smaller rod *r*.

The action of the machine is thus explained. By friction with the rubbers the glass becomes positively and the rubbers negatively electrified. If the rubbers were insulated, they would receive a certain charge of negative electricity which it would be impossible to exceed, for the tendency of the opposed electricities to reunite would be equal to the power of the friction to separate them. But the rubbers communicate with the ground by means of a chain; and, consequently, as fast as the negative electricity is

generated, it passes to earth. The positive electricity of the glass acts then by induction on the conductor, attracting the negative electricity. This negative electricity collects on the points opposite to the glass. Here its tendency to discharge becomes so high that it passes across the intervening space of air, and equalises the potentials of glass and conductor. The prime conductor is thus charged with positive electricity at approximately the same potential as the glass plate. The plate accordingly gives up nothing directly to the prime conductors; but its own positive charge is partly neutralised by the negative drawn from the points.

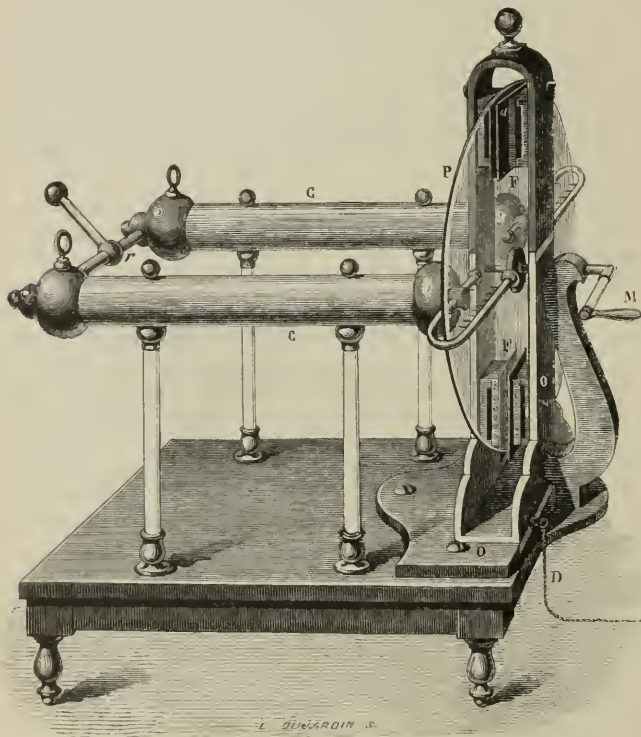

Fig. 736

If the hand is brought near the conductor when charged, a spark follows, which is renewed as the machine is turned. In this case the hand, being at zero potential and in a positive field, must have a negative charge. As the hand approaches, the difference of potential increases until a spark passes. With each spark the prime conductor is partially or entirely discharged, but becomes again electrified as the plate is turned.

769. **Precautions in reference to the machine.**—The glass, of which the plate is made, must be as little hygroscopic as possible. Of late ebonite has been frequently substituted for glass; it has the advantage of being

neither hygroscopic nor fragile, and of readily becoming electrified by friction. It cannot, however, be relied on, as its surface in time undergoes a change, especially if exposed to the light, whereby it becomes a conductor. The plate is usually from $\frac{1}{3}$ to $\frac{1}{2}$ of an inch in thickness, and from 20 to 30 inches in diameter, though these dimensions are not unfrequently exceeded.

The rubbers require great care, both in their construction and their preservation. They are commonly made of leather, stuffed with horsehair. Before use they are coated with powdered *aurum musivum* (tin sulphide), or graphite, or amalgam. The action of these substances is not very clearly understood. Some consider that it merely consists in promoting friction. Others, again, believe that a chemical action is produced, and assign in support of this view the peculiar smell noticed near the rubbers when the machine is worked. Amalgams, perhaps, promote most powerfully the disengagement of electricity. *Kienmayer's amalgam* is the best of them. It is prepared as follows :—One part of zinc and one part of tin are melted together and removed from the fire, and two parts of mercury stirred in. The mass is transferred to a wooden box containing some chalk, and then well shaken. The amalgam, before it is cold, is powdered in an iron mortar, and preserved in a stoppered glass vessel. For use a little cacao butter or lard is spread over the cushion, some of the powdered amalgam sprinkled over it, and the surface smoothed by a ball of flattened leather.

In order to avoid a loss of electricity, two quadrant-shaped pieces of oiled silk are fixed to the rubbers, so as to cover the plate on both sides : one at the upper part from *a* to *F*, and the other in the corresponding part of the lower rubbers. These flaps are not represented in the figure. Yellow oiled silk is the best, and there must be perfect contact between the plate and the cloth.

Ramsden's machine, as represented in fig. 736, gives only positive electricity. But it may be arranged so as to give negative electricity by placing it on a table with insulating supports. The conductor is connected with the ground by a chain, and the machine worked as before. The positive electricity passes off by the chain into the ground, while the negative electricity remains on the supports and on the insulated table. On bringing the finger near the uprights, a sharp spark is obtained.

Winter compared the working of an electric machine directly with the indications of an hygrometer, and found that the length of the spark obtainable is inversely as the hygrometric state.

770. **Maximum of charge.**—It is impossible to exceed a certain limit of electric charge with the machine, whatever precautions are taken, or however rapidly the plate is turned. This limit is attained when the rate of loss of electricity equals that of its production. The loss depends on three causes :—i. The loss by the atmosphere, and the moisture it contains. ii. The loss by the supports. iii. The recombination of the electricities of the rubbers and the glass.

The first two causes have been already mentioned. With reference to the last, it must be noticed that the electric charge increases with the rapidity of the rotation, until it reaches a point at which it overcomes the resistance presented by the non-conductivity of the glass. At this point, a portion of the two electricities separated on the rubbers and on the glass

recombines, and the charge remains constant. It is therefore ultimately independent of the rapidity of rotation.

771. **Armstrong's hydro-electric machine.**—In this machine electricity is produced by the disengagement of steam through narrow orifices. The discovery of the machine was occasioned by an accident. A workman having accidentally held one hand in a jet of steam, which was issuing from an orifice in a steam boiler at high pressure, while his other hand grasped the safety-valve, was astonished at experiencing a smart shock. Lord Armstrong (then Mr. Armstrong, of Newcastle), whose attention was drawn to this phenomenon, ascertained that the steam was charged with positive electricity, and, by repeating the experiment with an insulated locomotive, he found that the boiler was negatively charged. Armstrong believed that the electricity was due to a sudden expansion of the steam; Faraday, who afterwards examined the question, ascertained its true cause, which will be best understood after describing a machine which Armstrong devised for reproducing the phenomenon.

It consists of an insulated wrought-iron boiler (fig. 737), with a central fire, about 5 feet long by 2 feet in diameter, and provided at the side with a gauge O. C is a stopcock, and above this is the box B, in which are the tubes through which the steam is disengaged. On these are fitted jets of a peculiar construction, shown in the section of one of them, M, represented on a larger scale. They are lined with hard wood in a manner represented by the diagram. The box B contains cold water. Thus the steam, before escaping, undergoes partial condensation, and becomes charged with vesicles of water—a necessary condition, for Faraday found that no electricity is produced when the steam is perfectly dry.

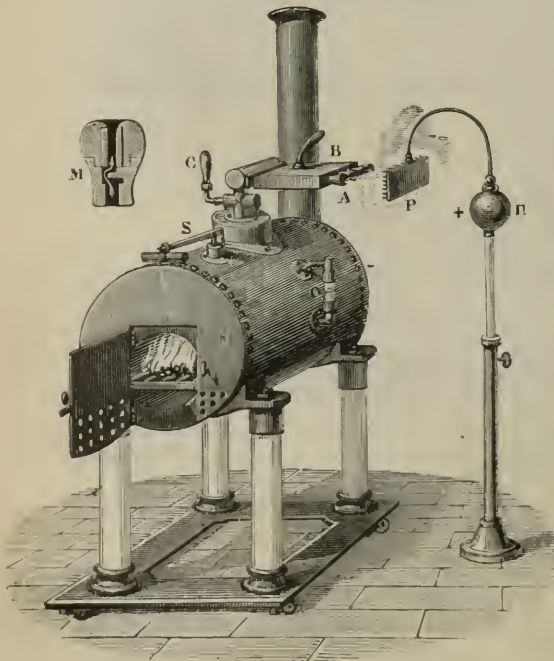

Fig. 737

It consists of an insulated wrought-iron boiler (fig. 737), with a central fire, about 5 feet long by 2 feet in diameter, and provided at the side with a gauge O. C is a stopcock, and above this is the box B, in which are the tubes through which the steam is disengaged. On these are fitted jets of a peculiar construction, shown in the section of one of them, M, represented on a larger scale. They are lined with hard wood in a manner represented by the diagram. The box B contains cold water. Thus the steam, before escaping, undergoes partial condensation, and becomes charged with vesicles of water—a necessary condition,

for Faraday found that no electricity is produced when the steam is perfectly dry.

The development of electricity in the machine was at first attributed to

the condensation of the steam, but Faraday found that it is solely due to the friction of the globules of water against the jet. For if the little cylinders which line the jets are changed, the kind of electricity is changed; and if ivory is substituted, little or no electricity is developed. The same effect is produced if any fatty matter is introduced into the boiler. In this case the linings are of no use. Electricity is disengaged in case the water is pure, and the addition of acid or saline solutions, even in minute quantity, prevents any disengagement of electricity. If turpentine is added to the boiler the effect is reversed—the steam becomes negatively, and the boiler positively, electrified.

With a current of moist air Faraday obtained effects similar to those of this apparatus, but with dry air no effect is produced.

When liquefied carbonic acid issues from the metal cylinder in which it is stored (384), the cylinder is found to be strongly positive, the electrification being due to the friction of particles of solidified carbonic acid against the sides of the jet.

772. **Electrophorus.**—One of the most simple and inexpensive machines for producing electricity is the *electrophorus*, invented by Volta. It is one of the class of *electrostatic induction* or *influence* machines, and differs entirely in principle from the frictional machine already described. When once charged, any amount of electricity can be obtained from it by intermittent inductive action. It consisted, as devised by Volta, of a cake of



Fig. 738

Fig. 739

resin, B (fig. 739), placed on a metal surface or enclosed in a metal dish; ebonite is now generally used instead of resin. A disc of ebonite, 10 inches in diameter and $\frac{1}{2}$ inch thick, is provided with a backing of metal, either brass or copper, called the *sole*, and the metal and ebonite are securely attached together. Besides this there is a metal disc A, called the *cover*, of a diameter somewhat less than that of the ebonite, and provided with a glass

handle. The mode of working is as follows:—All parts of the apparatus having been well dried, the ebonite is briskly flapped with catskin or flannel, and becomes thereby charged with negative electricity. The cover is put on, and after being touched with the finger, is raised by its insulating handle. It is found to be charged with positive electricity, and if the knuckle is brought near to it (fig. 739) a smart spark, half an inch or more long, passes. When the cover is replaced on the ebonite, touched, and raised, another spark is obtained from it, and so on indefinitely without any recharging of the ebonite. Thus, by once rubbing the plate of the electrophorus we can obtain from it an indefinitely large quantity of electricity. The explanation of the action is as follows:—When the ebonite is rubbed the negative electricity produced on its surface acts inductively through the dielectric upon the metal sole, which is earth-connected, producing positive electricity on its upper surface, the corresponding negative passing to earth.

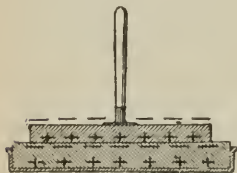

Fig. 740

The positive and negative attract each other, and the negative charge, which is increased by this induction, no longer remains exclusively on the upper surface of the ebonite, but penetrates into its interior. Hence the cover, when put on, is electrified only by induction (fig. 740), and there is practically no transfer of electricity to it from the ebonite; when it is touched the induced negative only passes to earth, the equal positive charge remaining on the under face. This positive electricity, when the cover is raised, becomes free, and may be withdrawn in the form of a spark. The electrophorus is more efficient when the ebonite is provided with its metal backing than when it is not so provided, for in the latter case the inductive action described above cannot take place, or takes place (through the ebonite to the table on which it rests) to a less extent, the negative charge produced by friction is not so great, and the inductive action on the cover is diminished.

The electrophorus is a good instance of the conversion of mechanical into electric energy. When the cover is lifted from the excited cake work must be expended in order to overcome the attraction of the electricity in the cake for the opposite electricity developed by induction on the cover; and the equivalent of this work appears in the energy of the electricity thus detached.

Of course, in raising the cover, work has to be done against gravity, but this work is the same whether the cover is electrified or not. When it is electrified, additional work must be done against electric force, and this is the work which is converted into energy of electric separation.

The best way to *discharge* the plate of an electrophorus is to pass rapidly the flame of a Bunsen burner over its surface.

773. **Lord Kelvin's water-dropping collector.**—In the electrophorus it is seen how we may, given an initial charge, obtain by intermittent inductive action an indefinitely large amount of electricity. Lord Kelvin's *water-dropping collector* may be given as another arrangement for the same purpose.

A and B (fig. 741) are insulated metal cylinders called the *inductors*, and are in metallic connection with two cylinders *a* and *b*, also insulated, called the *receivers*, each having a funnel the nozzle of which is in the centre of the cylinder. Water from the pipe *e* falls in drops through the metal taps *c* and *d*, the nozzles of which are in the centre of the cylinders A and B.

Take first the case of the cylinder A, and suppose it to possess a small positive charge at the outset, the drops as they fall will be charged negatively by induction, the corresponding positive going to earth, through *e*. Falling on the funnel of the receiver *b* they impart to it the whole of their charge, and the water as it issues will be neutral.

But the negative charge of *b* is shared with B, which is thus negatively electrified, and the drops which fall through it are positively electrified and give up their positive charge to *a*, which strengthens the positive of A. By this means even with a very slight original charge they will strengthen each other, until sparks pass. It is not even necessary to give a charge at the outset; the ordinary electricity of the atmosphere is generally sufficient.

The energy in this apparatus is derived from that of the falling body, and would be exactly equivalent to it if there were no loss, and if the drops reached the funnel without any velocity.

774. **The replenisher.**—For the purpose of maintaining constant the potential of the needle of the quadrant electrometer (796) Lord Kelvin devised a simple and interesting form of influence machine which is illustrated in fig. 742, while fig. 743 shows a horizontal section. A and B are conducting supports to which are attached portions of two insulated half-cylinders of brass. Slots are cut in the cylinders, through which springs, *a* and *b*, attached to the external supports, pass; *e* and *f* are other springs which pass through openings at the bottom of the cylinders (fig. 742), and are in metallic connection with each other. The two metallic wings C and D can be rotated by means of the spindle P, and during the rotation come into successive contact with the springs *a*, *e*, *b*, *f*. Suppose that the conductor A is connected with the needle of the electrometer which is charged with positive electricity, and that the spindle is rotated in the direction of the arrow. Also, let B be earth-connected. Neither of the wings C and D has any charge in the position shown in the figure; but as soon as C touches *e*,

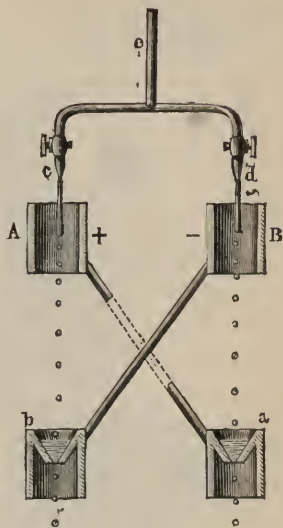

Fig. 741



Fig. 742

it receives a negative charge, while an equal positive charge passes by the wire *g* to the spring *f* and the wing *D*. As the rotation continues, *D*

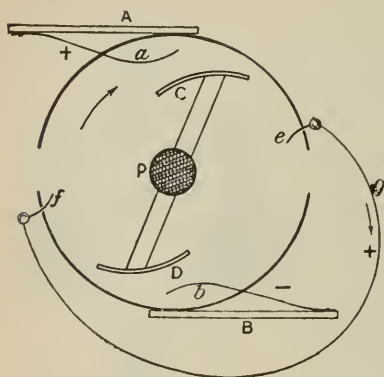

Fig. 743

with its positive charge comes in contact with the spring *a*, and the whole of its charge passes to *A*. The negative charge of *C* goes to earth through *B*, or increases the negative charge of *B*, if *B* is insulated, and the same process is repeated as the rotation is continued. Thus, at each half-revolution the charge on *A* is increased by a small amount, and its potential and that of the needle connected with it may be, by the continued rotation of the spindle, raised to any desired amount. The friction of the spindle bearings is so small that the wings may be rapidly spun round by

applying the finger to the milled head at the top of the spindle seen in the centre of the cover in fig. 742.

775. **Holtz's electric machine.**—We proceed to describe some of the more powerful machines for producing electricity of high potential, the action of which depends upon continuous electrostatic induction. The form represented in fig. 744 was invented by Holtz, of Berlin.

It consists of two circular plates of thin glass at a distance of 3 mm. from each other; the larger one, *AA*, which is 2 feet in diameter, is fixed by means of four wooden rollers *a*, resting on glass axes and glass feet. The diameter of the second plate, *BB*, is 2 inches less; it turns on a horizontal axis, which passes through a hole in the centre of the large fixed plate without touching it. In the plate *A*, on the same diameter, are two large apertures or *windows*, *F*, *F'*. Along the lower edge of the window *F*, on the posterior face of the plate, a band of paper, *p*, is glued, to which is connected a *tongue* of thin cardboard, *n*, joined to *p* by a thin strip of paper, and projecting into the window. At the upper edge of the window, *F'*, there are corresponding parts, *p'* and *n'*. The papers *p* and *p'* constitute the *armatures*. The two plates, the armatures, and their tongues are covered with shellac varnish, but more especially the edges of the tongues.

In front of the plate *B*, at the height of the armatures, are two brass *combs*, *O O'*, supported by two conductors of the same metal, *C C'*. In the front end of these conductors are two moderately large brass knobs, through which pass two brass rods terminated by smaller knobs, *r r'*, and provided with ebonite handles, *K K'*. These rods, besides moving with gentle friction in the knobs, can also be turned so as to be more or less near and inclined towards each other. The plate *BB* is turned by means of a winch *M*, and a series of pulleys which transmit its motion to the axis; the velocity which it thus receives is 12 to 15 turns in a second, and the rotation should take place in the direction indicated by the arrows, that is, towards the points of the cardboard tongues *n n'*.

To work the machine, one of the armatures $p p$ must be first *primed*, that is, positively or negatively electrified. This is effected by means of a plate of ebonite, which is excited by striking it with catskin; the two knobs $r r'$ having been connected so that the two conductors $C C$ form only one,

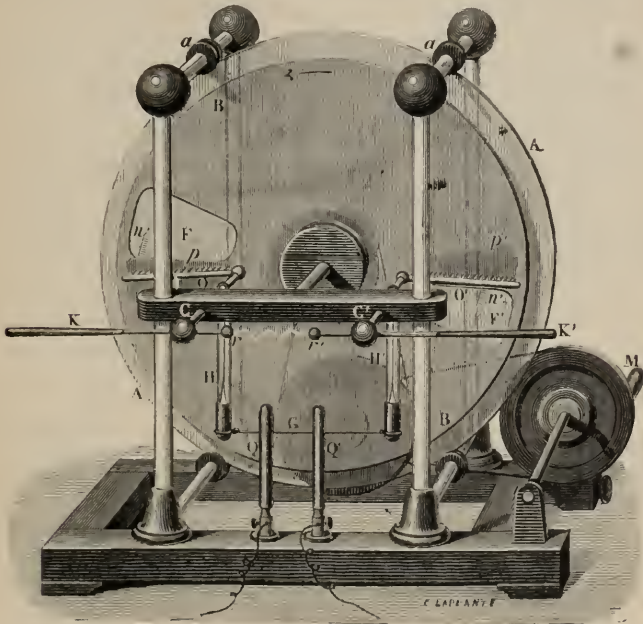

Fig. 744

as seen in fig. 745, which shows by a horizontal section, through the axis of rotation, the relative arrangement of the plates and of the conductors. The electrified ebonite is then brought near one of them— p , for instance—and the plate B is turned. The ebonite is charged with negative electricity, and



Fig. 745

this withdraws the positive electricity of the armature and charges it negatively. This latter, acting by induction through the plate BB as it turns on the conductors $OCC'O'$ (fig. 745), produces positive electrification on the points O , which collects on the front face of the movable plate; while at

the same time negative electricity, discharged from the comb O' , collects, like the former, on the front face of the plate B . Hence, the two electricities being carried along by the rotation, at the end of half a turn all the lower half of the plate B , from p to F' (fig. 746), is positively electrified, and its upper surface from p' to F negatively. But the two opposite electricities above and below the window F' concur in their action on the armature $p'n'$; the part p' is positively electrified, while negative electricity is liberated by the tongue n' , and is deposited on the inner face of the plate BB , which from its thinness almost completely neutralises the positive electricity on the anterior face.

The second armature thus becomes primed, and the same effect as at F' is produced at F on the armature pn —that is, the opposite electricities above and below pn act upon this armature in such a way that the negative charge of the part p increases, while the positive electricity which is liberated by the tongue n neutralises the negative electricity which comes from F' towards F ; and so forth, until, the machine having attained its

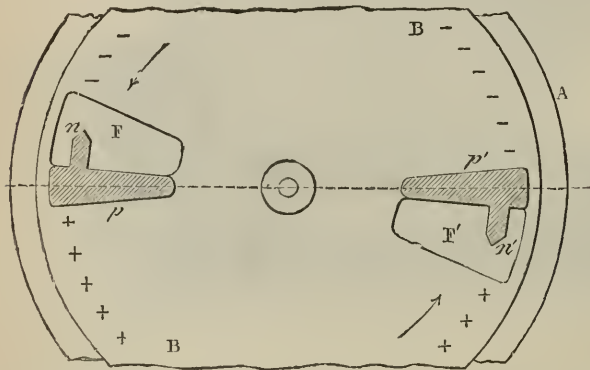

Fig. 746

maximum charge, there is equilibrium in all its parts. From that point it merely maintains its electrification, and in perfectly dry air it may work for a long time without its being necessary to employ the ebonite plate. If this is removed, and the knobs r and r' are moved apart (fig. 745) to

a distance dependent on the power of the machine, while the rotation is continued, a torrent of sparks strikes across from one knob to the other.

With plates of equal dimensions Holtz's machine is far more powerful than the ordinary electric machine (768). The power is still further increased by suspending to the conductors $C C'$ two *condensers* (781), or small Leyden jars, $H H'$, which consist of two glass tubes coated with tinfoil, inside and out, to a fifth of their height. Each of them is closed by a cork through which passes a rod, communicating at one end with the inner coating, and suspended to one of the conductors by a crook at the other end. The two external coatings are connected by a conductor, G . They are, in fact, only two small Leyden jars (786), one of them, H , becoming charged with positive electricity on the inside and negative on the outside; the other, H' , with negative electricity on the inside and positive on the outside. The jars must be charged up to the potential of the machine before a discharge between the knobs $r r'$ can occur. Without the jars the machine gives relatively thin and non-luminous sparks.

The current of the machine is utilised by placing in front of the frame two brass uprights, $Q Q'$, with binding screws in which are copper wires; then by means of the handles $K K'$, the rods which support the knobs $r r'$ are inclined, so that they are in contact with the uprights. The current being then directed by the wires, a battery of six jars can be charged in a few minutes, water can be decomposed, a galvanometer deflected, and Geissler's tubes illuminated.

Kohlrausch found that a Holtz machine with a plate 16 inches in diameter, and making 5 turns in three seconds, produced a constant current capable of decomposing water at the rate of $3\frac{1}{2}$ millionths of a milligramme in a second, that is, equal to '00034 ampere (940) approximately.

Rossetti, who made a series of measurements with a Holtz machine, found that the strength of the current is nearly proportional to the velocity of the rotation; it increases a little more rapidly than the rotation. The ratio of the velocity of rotation to the strength of the current is greater when the hygrometric state increases. The current produced by a Holtz machine is comparable with that of a voltaic couple. Its electromotive force and resistance are constant, provided the velocity of rotation and the hygrometric state are constant.

The electromotive force is independent of the velocity of rotation, but diminishes as the moisture increases; it is nearly 52,000 times as great as that of Daniell's cell.

The internal resistance is independent of the moisture, but diminishes rapidly with increased velocity of rotation. Thus with a velocity of 120 turns in a minute it is represented by 2810 million ohms (850), and with a velocity of 450 turns it is 646 million ohms.

Holtz's machine is very much affected by the moisture of the air; but Ruhmkorff found that by spreading on the table a few drops of petroleum, the vapours which condense on the machine protect it against the moisture of the atmosphere.

Holtz's machine affords a means of making a curious experiment on *reversibility*. If the two combs of a machine in the ordinary state are connected with the poles of a second similar one, which is then set in action, the combs of the first become luminous, and the plate begins to rotate, but in the opposite direction to its ordinary course; the electricity thus transmits the motion of the second machine to the first: the one expends what the other produces. It may also be observed that the two machines are connected by opposite poles, and the system constitutes a circuit which is traversed in a definite direction by a continuous electric current.

A very simple and efficient machine of this kind is made by Voss of Berlin. One with a plate of 10 inches diameter produces a spark of 4 to 5 inches.

776. Wimshurst's machine.—This is the simplest and most efficient of all induction machines.

It consists (fig. 747) of two circular glass discs, P and P' , mounted on a fixed horizontal spindle in such a way as to be rotated in opposite directions at a distance of not more than a quarter of an inch apart. Both discs are well varnished, and attached to the outer surface of each, near the circumference, are narrow radial sectors of tinfoil arranged at equal angular distances apart.

Attached to the fixed spindle on which the discs rotate is a bent conducting rod, at the ends of which are two fine wire brushes; twice during each revolution two diametrically opposite conductors are put in connection with each other by means of this conductor, as they just graze the tips of the brushes. At the back is a similar one at right angles to that in front, and there is a position of maximum efficiency, which is when they make an angle of 45° with the fixed collectors. These diametral conductors need not be specially insulated. There are two forks provided with combs, p p' , directed towards each other, and towards the two discs which rotate between

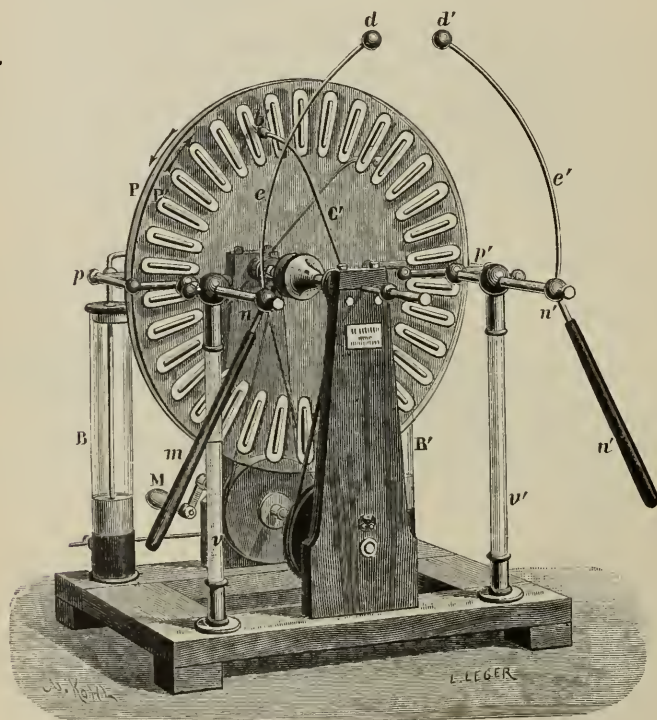

Fig. 747

them; they are shown in fig. 748. B and B' are Leyden jars which may be connected to the electrodes of the machine by metal rods, or may be detached at pleasure.

The machine is self-exciting, and requires neither friction, nor the spark from any outside exciter, to start it. It is one of the most remarkable features of this machine, that under ordinary conditions it attains its full power after the second or third turn. The initial charge is probably obtained from the electricity of the air, or from the frictional resistance against it.

With a machine having plates 17 inches in diameter, a powerful spark discharge passes between the two spark balls, $d d'$, when they are 4 to 5 inches apart, in regular succession, at the rate of 2 or 3 for every turn of the

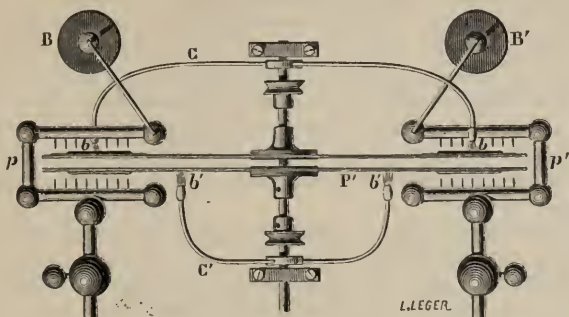

Fig. 748

handle. A machine with 12 plates, 30 inches in diameter, when driven at a speed of 200 turns per minute, produces sparks between the terminals of $13\frac{1}{2}$ inches in length.

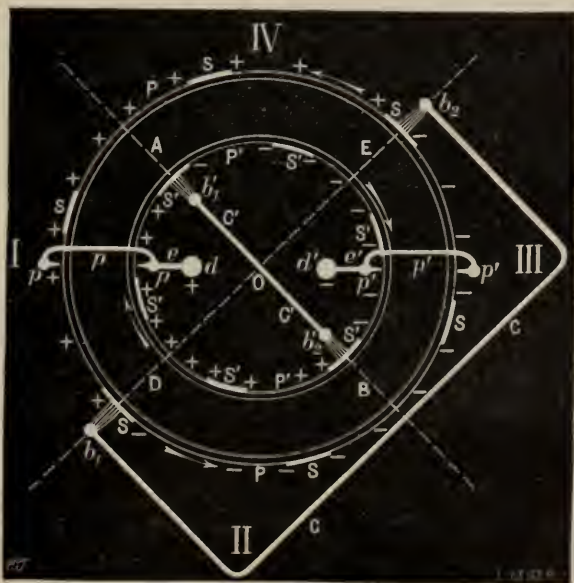

Fig. 749

The action of the machine may be explained as follows:—In fig. 749 the plates P P' are indicated by sections of cylinders; $b_1 C b_2$ and $b'_1 C' b'_2$ are

the diametral conductors, p p' the combs which communicate with the discharge electrodes, and SS' the radial sectors, of which only six are represented on each plate for the sake of clearness. Experiment shows that the combs take no part in the development of electricity; they are merely collectors. This machine, as already remarked, is self-exciting, that is, it is not necessary to provide a priming charge as it is with the Holtz machine. But in order to understand its action we must assume a difference of potential, as small as we like, between two parts of it. The assumption is justified since we never find two bodies, insulators or insulated conductors, exactly at the same potential. We will suppose, then, that the half ADB of the plate P' possesses a feeble positive charge, and the other half, BEA , a feeble negative charge.

By induction the positive charge induces on the sectors of the plate P , as they rotate, a negative charge on the side towards the glass, and an equal positive charge which is carried off by the brush b_1 , and charges the sector under b_2 . Thus the two halves of the plate P' separated by its diametral conductor have induced on the two halves of the plate P , separated by the conductor b_2Cb_1 , opposite electric charges. In the same way the positive charges of the portion EAD react on the sectors of the plate P' which are moving to meet them. Consequently, after their passage under the brush b'_1 , the sectors carry a new negative charge, the corresponding positive charge passing to the brush b'_2 . In addition, the sectors under b'_2 acquire a new positive charge, by induction from the negative charges spread over the portion DBE of the plate P . Thus by mutual reaction the charges of the two plates are increased until the rate of gain is balanced by the rate of loss due to dissipation and leakage.

The diagram (fig. 749) represents the electric states of the plates. Each of them is divided by its diametral conductor into two regions, respectively positive and negative. Positive electricity is carried to the comb p by both plates, and is there collected; similarly, both plates carry negative electricity to the comb p' .

Since the combs play no part in the production of electricity in this machine, it is immaterial whether the knobs d d' are in contact or not when the machine is started. Further, this machine does not reverse its sign during action—as the Holtz and Voss machines frequently do when the spark gap is increased beyond striking distance.

777. Work required for the production of electricity.—In all electric machines electricity is only produced by the expenditure of energy, as will at once be seen by a perusal of the preceding descriptions. The action of those machines, however, which work continuously is somewhat complex. Not only is electricity produced, but heat also; and it has been hitherto impossible to estimate separately the work required for the heat from that required for the electricity. This is easily done in theory but not in practice: it would be, for instance, difficult to determine the temperature of the cushion or of the plate of a Ramsden machine.

By means of a Lane electrometer (793) it was found that, taking as unit the quantity of electricity produced by one turn of a Ramsden machine with a plate 39 inches in diameter, that produced by a Holtz machine with a plate of 21 inches was 0.86; but as for the same work the former made 1

and the latter 10 turns in a second, it follows that the quantities produced were as 1 : 8.6. Comparing the quantities per unit of surface, the yield of the Holtz machine is more than 12 times that of the Ramsden.

In lifting the plate off a charged electrophorus a certain expenditure of energy is needed (772). With a Holtz machine it may be readily shown by experiment that there is a definite expenditure of energy in working it. If such a machine is turned without having been charged, the work required is only that necessary to overcome the passive resistances due to friction. If, however, a charged ebonite plate is approached to one of the sectors, as soon as the peculiar sound indicates that the machine is at work, it will be observed that there must be a distinct increase in the mechanical effort necessary to work the machine.

From the relation between the quantity of heat produced by the current of a Holtz machine working under definite conditions, and the amount of work expended in producing the rotation of the plate, Rossetti made a determination of the mechanical equivalent of heat, which gave the number 1397, agreeing therefore very well with the numbers obtained by other methods (506).

EXPERIMENTS WITH THE ELECTRIC MACHINE

778. **Electric spark.**—One of the most curious phenomena observed with the electric machine is the spark drawn from the conductor when a finger is

Fig. 750

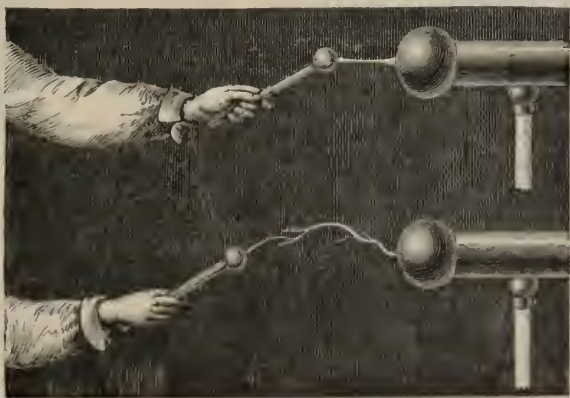

Fig. 751

presented to it. The positive electricity of the conductor produces by induction negative electricity on the finger, an equal charge of positive electricity passing to the floor and walls of the room. The difference of potential between conductor and finger, and the density of the electrification, increases until a moment arrives when the insulation of the air gives way, and discharge occurs with a smart crack and a spark.

The spark is instantaneous, and is accompanied by a sharp prickly

sensation, more especially with a powerful machine. Its shape varies. When it strikes at a short distance it is rectilinear, as seen in fig. 750. Beyond two or three inches in length the spark becomes irregular, and has the form of a sinuous curve with branches (fig. 751). This latter appearance is seen in the discharge of lightning.

A spark may be taken from the human body by aid of the *insulating stool*, which is simply a low stool with stout glass legs. The person standing on this stool touches the prime conductor, and, as the human body is a conductor, the electricity is distributed over its surface as over an ordinary insulated metallic conductor. The hair stands on end in consequence of repulsion, a peculiar sensation is felt on the face, and if another person, standing on the ground, presents his hand to any part of the body, a smart crack with a pricking sensation is produced.

A person standing on an insulated stool may be negatively electrified by being struck with a catskin. If the person holding the catskin stands on an insulated stool, the striker becomes positively and the person struck negatively electrified.

779. **Electric chimes.**—The *electric chimes* is a piece of apparatus consisting of three bells suspended from a horizontal metal rod (fig. 753). Two

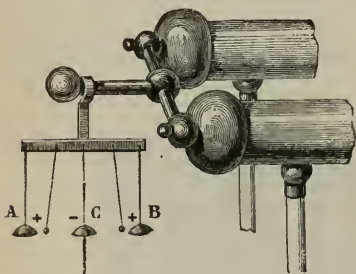

Fig. 753

of them, A and B, are in metallic connection with the conductor; the middle bell hangs by a silk thread, and is thus insulated from the conductor, but is connected with the ground by means of a chain. Between the bells are small copper balls suspended by silk threads. When the machine is worked, the bells A and B, being positively electrified, attract the copper balls, and after contact repel them. Being now positively electrified, they are in turn attracted by the middle bell, C,

which is charged with negative electricity by induction from A and B. After contact they are again repelled, and this process is repeated as long as the machine is in action.

Fig. 754 represents an apparatus originally devised by Volta for the purpose of illustrating what he supposed to be the motion of hail between two clouds oppositely electrified. It consists of a tubulated glass shade with a metal base, on which are some pith balls. The tubulure has a metal cap, through which passes a brass rod, provided with a metal disc or sphere at the lower end, and at the upper with a ring, which touches the prime conductor.

When the machine is worked, the sphere becoming positively electrified attracts the light pith balls, which are then immediately repelled, and, having lost their charge of positive electricity, are again attracted, again repelled, and so on, as long as the machine continues to be worked. An amusing modification of this experiment is frequently made by placing between the two plates small pith figures, somewhat loaded at the base. When the machine is worked, the figures execute a regular dance.

780. **Escape of electricity by points.**—The electric *whirl* or *vane* consists of five or six wires, terminating in points, all bent in the same direction, and fixed in a central cap, which rotates on a pivot (fig. 755). When the apparatus is placed on the conductor, and the machine worked, the whirl begins to revolve in a direction opposite that of the points. This motion is owing to a repulsion between the electricity of the points and that which they impart to the adjacent air by conduction. The electricity, being accumulated on the points in a high state of density, passes into the air, and, imparting thus a charge of electricity, repels this electricity, while it is itself repelled. That this is the case is evident from the fact that on approaching the hand to the whirl while in motion, a slight draught is felt, due to the movement of the electrified air, while *in vacuo* the apparatus does not act at all. This draught or wind is known as the *electric aura*.

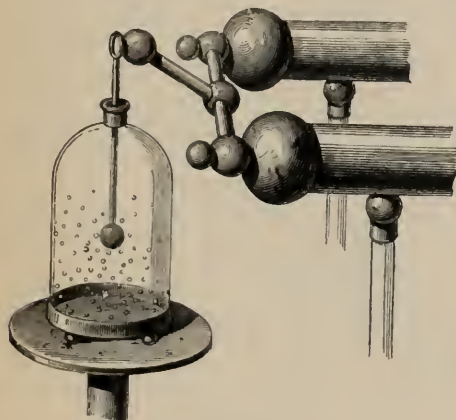

Fig. 754

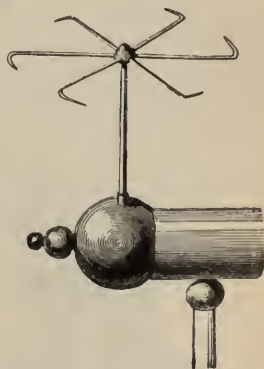

Fig. 755

If the experiment is made in water, the apparatus remains stationary, for water is a good conductor; but in olive oil, which is a bad conductor, the whirl rotates.

When the electricity thus escapes by a point, the electrified air is repelled so strongly as not only to be perceptible to the hand, but also to engender a current strong enough to blow out a candle. Fig. 756 shows this experiment. The same effect is produced by placing a taper on the conductor and bringing near it a pointed wire held in the hand (fig. 757). The current arises in this case from the flow of air electrified with the contrary electricity which escapes by the point under the influence of the machine. The loss of electricity in this way by contact with easily moving bodies is analogous to the transmission of heat by convection.

The production of the electric aura is accompanied by luminous phenomena which can be seen in the dark. If positive electricity escapes from the point, a violet aigrette is formed; while when the electricity is negative a small brilliant star forms on the point.

An interesting effect of the electric discharge from a point is exhibited when high-pressure steam escapes from a nozzle in the neighbourhood of the

point. This can conveniently be shown by throwing the shadow of the jet on a screen. When there is no escape of electricity the jet is nearly transparent and the shadow is slight; as soon, however, as the point begins to discharge electricity, the opacity of the jet increases in a very marked way,

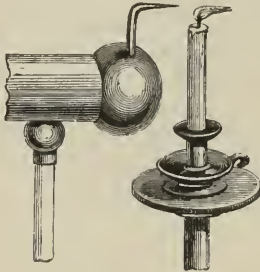

Fig. 756

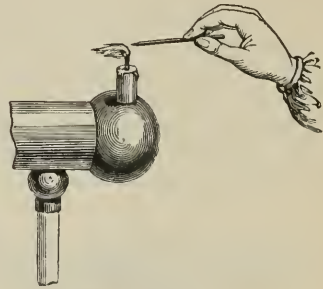

Fig. 757

the shadow becoming dark and distinct. The effect shows that the electrification makes the steam jet condense into water drops. A similar effect is produced by the action of Röntgen rays (983) on a steam jet.

The action of points in electrifying, and so producing the agglomeration of fine particles of dust or moisture, may be further illustrated by the following simple experiment. A glass cylinder, AB, shown in fig. 758 with the front half removed, can be filled with smoke

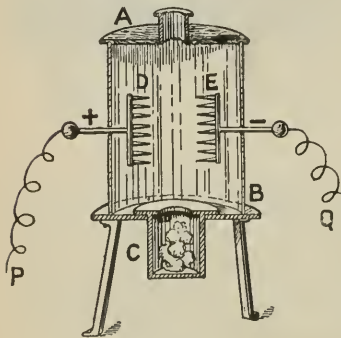

Fig. 758

by placing smouldering german tinder or brown paper in the chamber beneath. Through holes on opposite sides of the cylinder, rods pass which terminate in metallic combs, and have wires P Q attached to them by which they may be connected to the electrodes of an induction machine. On giving the machine two or three turns the smoke is rapidly deposited and the inside becomes quite clear. The smoke consists of solid particles, which become polarised by induction, and attract each other like the particles of silk in fig. 735. They thereby

become agglomerated, and are deposited on the sides, where they are retained if the sides are coated with glycerine. Nahrwold proved that if air is freed from dust by filtration, it takes little if any charge from an electrified point.

This phenomenon is employed industrially in the deposition of finely suspended powders, as in lead works. Two conductors provided with points are connected respectively with a positive and negative source of electricity: the powder electrified by the one point is repelled and is precipitated on the other.

CHAPTER IV

CONDENSATION OF ELECTRICITY

781. **Condensers.**—These are apparatus for condensing or accumulating a large quantity of electricity on a comparatively small surface. The phenomena of condensation may be conveniently illustrated by means of *Epinus's condenser* (fig. 759), which consists of two circular brass plates A and B, mounted on glass legs and provided with pith-ball pendulums. Between these is a support C for a glass plate or other solid insulator, and all these can be moved along a support and fixed in any position.

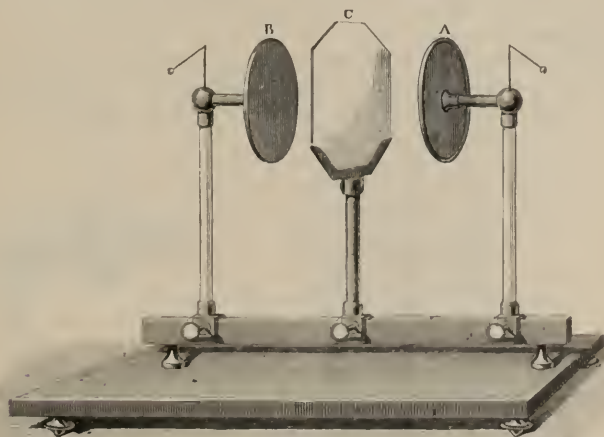

Fig. 759

First, let the plate C be removed, and let B, which is connected with a pith-ball electroscope, or, still better, by means of a wire with the cap of a gold-leaf electroscope, receive a charge of positive electricity, while A is earth connected. The divergence of the leaves of the electroscope indicates the potential of B, and this divergence diminishes when A is pushed nearer to B, showing that the potential of B has fallen. If the plate A is moved away, the divergence rises to the original amount, indicating that it has recovered the original potential.

Now the charge Q of any conductor equals CV (760), where C is its capacity and V its potential, or rather the difference between its potential and that of surrounding conductors; and since, apart from losses by leakage, the quantity of electricity on the plate B is not altered in this series of operations, while the potential is lowered, it follows necessarily that the capacity of the plate B must have been increased by the presence of the second one; for $Q = C'V'$, where C' and V' are respectively the new capacity and the new potential of B ; and since V' is less than V , C' must be greater than C .

Let the charge on B be now gradually increased, until the indication of the electroscope is the same as it was at first. B has now the same potential as it had originally, the larger charge corresponding to the increased capacity, as expressed by the equation $Q' = VC'$. The effects described are more marked if the two plates are separated by a solid dielectric such as glass or ebonite, instead of air.

It follows from this series of experiments that the presence of the second plate has enabled the first one to take a greater charge of electricity, for the same potential, than when it is alone. This property is what is called the *condensation* of electricity, and any arrangement in which one conductor is placed in connection with a source of electricity separated by an insulator from a second conductor, in conducting communication with the earth, is called a condenser, the former plate being the *collecting*, and the other the *condensing* plate.

782. **Slow discharge and instantaneous discharge.**—While the plates A and B are in contact with the glass (fig. 760), and A insulated, the condenser may be discharged either by a slow or by an instantaneous discharge.

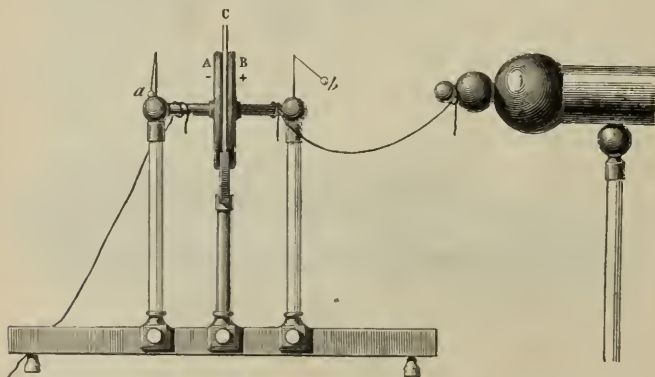

Fig. 760

For slow discharge, the plate B is touched with the finger and a spark passes. If A is now touched, a spark passes, and so on by continuing to touch alternately the two plates. The complete discharge may require a very large number of alternate contacts of the finger with A and B .

An instantaneous discharge may be effected by means of the *discharging rod* (fig. 761). This consists of two bent brass rods, terminating in knobs

and joined by a hinge. When provided with glass handles, as in fig. 761, it forms a *glass discharging rod*. In using this apparatus one of the knobs is pressed against one plate of the condenser, and the other knob brought near the other. At a certain distance the opposite electricities unite and a spark strikes from the plate to the knob.

When the condenser is discharged by a metal wire no sensation is experienced, even though the latter be held in the hand; of the two conductors the electricity chooses the better, and hence the discharge is effected through the metal, and not through the body. But if, while one hand is in contact with the plate A, the other touches the plate B, the discharge takes place through the breast and arms, and a considerable shock is felt; and the larger the capacity of the condenser, and the greater the electric charge, the more violent is the shock.

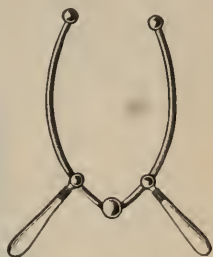

Fig. 761

783. Dielectric constant. Specific inductive capacity.—The quantity of electricity which can be accumulated on each plate is proportional to the difference of potential of the two plates and to the surface of either of them; it decreases as the insulating plate C is thicker, and differs with its material. For instance, the capacity of the condenser is twice as great (approximately) when the plates are separated by paraffin wax as when they are separated by air. Up to the present it has been tacitly assumed that electric actions are exerted at a distance, and the medium has been looked upon as an inert mass through which the forces can act, but which itself is destitute of any active properties. The researches of Faraday, however, prove that this is not the case; that the medium is of fundamental importance, and that it is in it and not in the conductors that the electrification must be sought. If the medium does play the essential part in the phenomena of induction, it is not likely that all insulating bodies possess it in the same degree. This seems to have been known to Cavendish. To determine this point Faraday used the apparatus represented in fig. 762, of which fig. 763 represents a vertical section. It consists of a brass sphere made up of two halves, P and Q, which fit accurately into each other, like the Magdeburg hemispheres. In the interior of this spherical envelope there is a smaller brass sphere C, connected with a metal rod, terminating in a ball B. The rod is insulated from the envelope PQ by a thick layer of shellac, A. The space *mn* receives the substance whose inductive power is to be determined. Thus the surfaces of the spheres C and P play the part of the two plates in Epinus's condenser. The foot of the apparatus is provided with a screw and stopcock, so that it can be screwed on the air-pump, and the air in *mn* either rarefied or exhausted.

Two such apparatus perfectly identical are used, and at first they only contain air. The envelopes PQ are connected with the ground, and a charge Q of positive electricity is communicated to C through the knob B. Let V be the potential of C as measured by a gold-leaf electroscope, or better by a quadrant electrometer (796), and C its capacity, then $Q = CV$. The sphere C thus becomes charged like the inner coating of a Leyden jar (786). The layer *mn* represents the insulator or dielectric which separates

the two coatings. The knob B is now placed in metallic connection with the knob B' of the other apparatus, and the potential falls to $\frac{V}{2}$, showing that the electricity has become equally distributed on the two spheres, as might have been anticipated, since the pieces of apparatus were alike in all respects, and each contained air in the space *mn*.

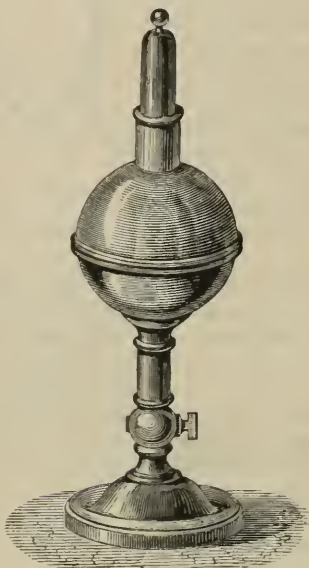

Fig. 762

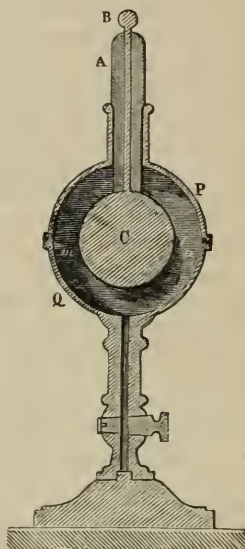

Fig. 763

This experiment having been made, the space *mn* in the second apparatus is filled with the substance whose inductive power is to be determined: for example, shellac. As before, the air condenser receives a charge Q , and its potential is V . When the knobs of the two apparatus are connected together, the potential as indicated by the electrometer is *less* than half what it was before; call it V' , and let C' be the capacity of the shellac condenser. Then, since the total quantity of electricity has not altered, we have $Q = VC = V'(C + C')$, from which is obtained $\frac{C'}{C} = \frac{V - V'}{V'}$. For measuring the potentials Faraday used Coulomb's torsion balance (753), and the value he obtained for $\frac{C'}{C}$ in the case of shellac was 1.55. As the two condensers were exactly alike in all respects, except in the material of the dielectric, the ratio C'/C gave the relative *inductive powers* of shellac and air. This ratio Faraday called the *specific inductive capacity* of shellac, that of air being taken as unity.

By the following simple experiment the influence of the medium may be shown:—At a fixed distance above a gold-leaf electroscope let an

electrified sphere be placed, by which a certain divergence of the leaves is produced. If now, the charge remaining the same, a disc of sulphur or of shellac is interposed, the divergence increases, showing that inductive action takes place through the sulphur to a greater extent than through a layer of air of the same thickness.

The following are the mean values which have been obtained, by various improved methods, for the specific inductive capacities, or *dielectric constants*, of various materials. Their exact determination presents considerable difficulty :—

Air	1'00	Sulphur	3'97
Paraffin	2'02	Gutta-percha	4'2
India rubber	2'22	Glass	5 to 6
Shellac	3'04	Alcohol	25
Ebonite	3'42	Water	80

A condenser with a glass plate would thus have five or six times the capacity of an air condenser of the same dimensions, or the same capacity as an air condenser of the same surface, but five or six times as thin.

Hopkinson found the following numbers for the dielectric constants of certain liquids: petroleum 2'10, oil of turpentine 2'23, olive oil 31'6, and castor oil 4'78.

784. **Limit of the charge of condensers. Dielectric strength.**—There is a limit in the case of each condenser beyond which it cannot be charged. The effect of dielectric polarisation (766) is to put the medium into a state of strain from which it is always trying to release itself; the potential energy of the strained medium is the equivalent of the work done in charging the condenser. It is as if two surfaces were pulled together by elastic threads which repelled each other laterally. When the strain exceeds a certain limit, a discharge takes place through the mass of the dielectric, generally accompanied by light and sound, and with a temporary or permanent rupture of the dielectric according as it is fluid or solid. This is what occurs when a substance—glass, for instance—is exposed to a continually increasing weight; a point is ultimately reached at which the glass gives way, and the weight at that point is a measure of the resistance to fracture of the glass. In like manner, the point at which the electric discharge takes place is a measure of the *electric strength* of the dielectric. This electric strength is greater in glass than in air, and in dense than in rarefied air.

Thus to produce a spark of 0'5 cm. in air at the pressures 20, 180, and 685 mm. respectively, the potentials required were 3'23, 12'2, and 36.

The electric strength of an insulator is frequently given in terms of the difference of potential per centimetre required to break down the insulation. The following are examples :—

Substance	Electric strength
Mica	2,000,000 volts per cm. (848)
Ebonite	540,000 „ „
Air film 2 mm. thick	57,000 „ „
„ 16 „	27,000 „ „

Professor Trowbridge has shown that, under an electromotive force of

2,000,000 volts, air at ordinary pressure becomes a conductor. Conductors charged to this potential emit a luminous discharge to earthed conductors, and air behaves electrically as a rarefied gas does at lower electromotive forces.

We may, following Maxwell, further illustrate this point by the twisting of a wire: a wire in which a permanent twist is produced by the application of a small mechanical couple corresponds to the case of the conduction of electricity in a good conductor; one which, having been twisted, reverts to its former shape when the twisting couple is removed, is completely elastic, and corresponds to a perfect insulator with respect to the charge employed. If no permanent twist can be given to the wire by a force which does not break it, the wire is brittle. A dielectric such as air, which does not transmit electricity except by disruptive discharge, may be said to be electrically brittle. Thus the electric elasticity of a medium is inversely as its dielectric constant. The electric elasticity of a perfect conductor is zero; its dielectric constant is infinite.

785. **Fulminating pane. Franklin's plate.**—This is a simple form of the condenser, and consists of a glass plate fixed in a wooden frame (fig. 764); on each side of the glass, pieces of tinfoil are fastened opposite each other,

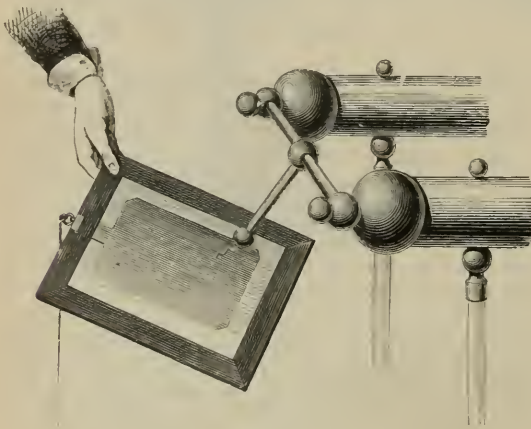

Fig. 764

leaving a space free between the edge and the frame. It is well to cover this part of the glass with an insulating layer of shellac varnish. One of the sheets of tinfoil is connected with the ring on the frame by a strip of tinfoil, so that it can be connected with the ground by means of a chain. To charge the pane the insulated side is connected with

the machine. As the other side communicates with the ground, the two coatings play exactly the part of the condenser. On both plates there are accumulated large quantities of contrary electricities.

The pane may be discharged by touching one knob of the discharger against the lower surface, while the other is brought near the upper coating. A spark ensues, due to the recombination of the two electricities; but the operator experiences no sensation, for the discharge takes place through the wire. But if the connection between the two coatings is made by touching them with the hands, a violent shock is felt in the hands and breast, for the combination then takes place through the body.

786. **Leyden jar.**—The *Leyden jar*, so named from the town of Leyden, where it was invented, is essentially a modified plate condenser, or fulminating

pane rolled up. Fig. 765 represents a Leyden jar of the usual French shape in the process of being charged. It consists of a glass jar of any convenient size, the interior of which is either coated with tinfoil or filled with thin leaves of copper, or with gold-leaf. Up to a certain distance from the neck the outside is coated with tinfoil. The neck is provided with a cork, through which passes a brass rod, which terminates at one end in a knob, and communicates with the metal in the interior. The metallic coatings are called respectively the *inner* and *outer coatings* or *armatures*. Like any other condenser, the jar is charged by connect-

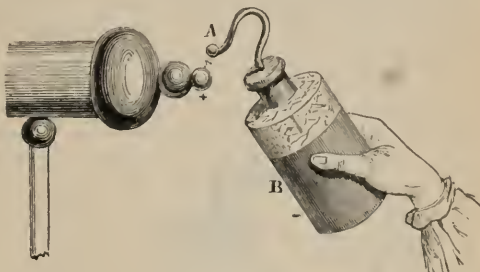

Fig. 765

ing one of the coatings with the ground, and the other with the source of electricity. When it is held in the hand by the outer coating, and the knob presented to the positive conductor of the machine, positive electricity is accumulated on the inner and negative electricity on the outer coating. The reverse is the case if the jar is held by the knob, and the outer coating presented to the machine. The positive charge acting inductively across the dielectric glass produces a negative charge on the opposite side of the glass, an equal positive charge passing to earth. Thus it will be seen that the action of the jar is the same as that of the plate condenser, and all that has been said of this applies to the jar, substituting the two coatings for the two plates A and B of fig. 760.

When a quantity $+Q$ of electricity passes from the source to the inner coating of the jar, an equal quantity $+Q$ goes to earth from the outer coating. The jar when charged contains equal quantities of positive and negative electricity, and the energy of charging has been spent in separating the two.

If the outer coating is insulated the jar cannot be charged. When the inner coating is raised to V , the potential of the machine, the outer coating will have a potential, V' , differing only slightly from V , and the charge $Q = (V - V')C$ will be very small, however large C may be. Hence one coating must be earthed, or, what practically comes to the same thing, one coating must be connected to the positive and the other to the negative electrode of the machine.

Like any other condenser, the Leyden jar may be discharged either slowly or instantaneously. For sudden discharge the two coatings are connected by means of the simple discharger (fig. 766). Care must be taken to touch *first* the external coating with the discharger, otherwise a smart shock will be felt. For slow discharge the jar is placed on an insulated plate, and first the inner and then the outer coating touched, either with the hand or with a metallic conductor. A slight spark is seen at each discharge.

Fig. 767 represents a very pretty experiment for illustrating the slow

discharge. The rod terminates in a small bell, *d*, and the outside coating is connected with an upright metal support, on which is a similar bell, *e*. Between the two bells a light brass ball is suspended by a silk thread. The jar is then charged in the usual manner and placed on the support *m*. The bell *d*, being connected with the inner coating, is positively charged, and

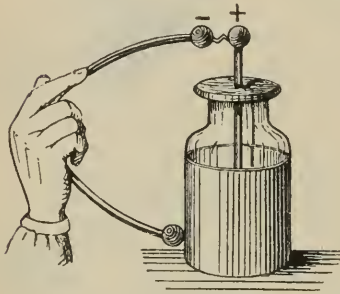

Fig. 766

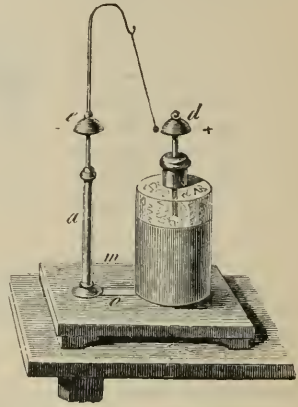

Fig. 767

attracts the light brass ball, which after contact is immediately repelled, and strikes against the second bell, to which it imparts its free electricity. Being now neutralised, it is again attracted by the first bell, and so on for some time, especially if the air is dry, and the jar somewhat large. This is sometimes spoken of as the *convective discharge*, since the electricity is carried by moving ponderable bodies.

787. **Leyden jar with movable coatings.**—This apparatus (fig. 768) is used to demonstrate that in the Leyden jar the opposite electricities are not accumulated on the coatings, merely, but that the charge is stored up in the glass, which is thereby strained, the potential energy of the strain being the

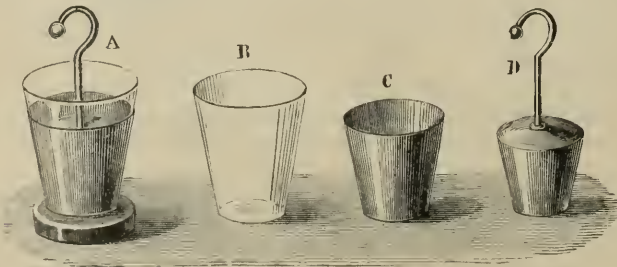

Fig. 768

equivalent of the work done in charging the jar. It consists of a slightly conical glass vessel, B, with movable coatings of zinc or tin, C and D. These separate pieces placed one in the other, as shown in figure A, form a complete Leyden jar. After the jar is charged, it is placed on

an insulating cake; the inner coating is first removed by the hand, or better by a glass rod, and then the glass vessel. The coatings are found to contain little or no electricity, and if they are placed on the table they are restored to the neutral state. Nevertheless, when the jar is put together again, as represented in the figure at A, a shock may be taken from it almost as strong as if the coatings had not been removed. It is therefore concluded that the coatings principally play the part of conductors, distributing the electricity over the surface of the glass, which thus becomes polarised.

The experiment may be conveniently made without any special form of apparatus by forming a Leyden jar, of which the inside and outside coatings are of mercury, and charging it; then, having mixed the two coatings, that is, the mercury inside with that outside, the apparatus is put together again, upon which a discharge may be once more taken.

Franklin in 1748 charged the water inside a bottle by means of a wire passing through the cork. The outside of the bottle was coated with lead-foil. The water was then poured into another vessel and found to be unelectrified, whereas when fresh water was put into the bottle a shock was felt when one hand grasped the lead-foil and the other touched the water inside. He thus showed that the glass was the essential part of the apparatus.

788. **Lichtenberg's figures.**—This experiment well illustrates the opposite electric conditions of the two coatings of a Leyden jar. Holding a jar charged with positive electricity by the hand, a series of lines is drawn with the knob on a cake of resin or vulcanite; then the jar having been placed on an insulator, and grasped by the knob, another series is traced by means of the outer coating. If now a mixture of red-lead and flour of sulphur (751) is sprinkled on the cake, the sulphur will attach itself to the positive lines, and the red-lead to the negative lines; the reason being that in mixing the powders, the sulphur has become negatively electrified, and the red-lead positively. The sulphur will arrange itself in tufts with numerous diverging branches, while the red-lead will take the form of small circular spots, indicating a difference in the two electricities on the surface of the resin (804). These figures form, in short, a very sensitive electroscope for investigating the distribution of electricity on an insulating surface.



Fig. 769

Fig. 769 represents the appearance of a plate of resin which has been touched by the knob of a Leyden jar charged with positive electricity, and has then been dusted with lycopodium powder.

Lichtenberg figures can be obtained without the aid of a Leyden jar, as follows:—Let an ebonite plate be briskly rubbed with flannel, and so

charged with negative electricity. If a pointed wire held in the hand is moved over the surface so as to form any letter or pattern (it need not actually *touch* the plate), and the mixture of red-lead and flour of sulphur is sifted over the surface, the pattern is seen by the adherence of the sulphur to its outlines.

789. **Residual charge.**—Suppose a condenser to be formed of a plate of shellac and movable metal plates. Let it be charged, retained in that state for some time, and afterwards completely discharged. On removing the metal coatings and examining both surfaces of the insulator, they show no signs of electricity. After some time, however, each face exhibits the presence of some electricity of the same kind as that of the plate with which it was in contact while the apparatus was charged. This is explained, by some, as a kind of *electric absorption*.

A phenomenon frequently observed in Leyden jars is of the same nature. When a jar has been discharged, and is then allowed to stand a short time, it exhibits a second charge, which is called the *residual charge*. The jar may be again discharged, and a second residue will be left, feebler than the first, and so on, for three or four times. Indeed, with a delicate electroscope a long succession of such residues may be demonstrated. The residue is greater the longer the jar has remained charged. The magnitude of the residue further depends on the amount of the charge, and also on the degree in which the metal plates are in contact with the insulator. It varies with the nature of the substance, but there is no residual charge with either liquid or gaseous dielectrics. Faraday found that with paraffin the residue was greatest, then with shellac, while with glass and sulphur it was least of all. Kohlrausch has found that the residual charge is nearly proportional to the thickness of the insulator. If successive small charges, alternately positive and negative, be imparted to the jar, it is found that the residual charges come out in the reverse order to that in which the original charges go in.

Maxwell proved that a dielectric composed of strata of different insulators may exhibit the phenomena of the residual charge, even though none of the substances composing it exhibit it when alone.

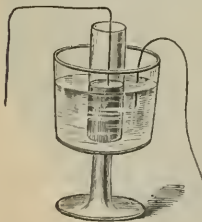

Fig. 770

A series of superimposed liquid insulators with definite boundaries shows a residual charge; this is not the case if they are well mixed by shaking.

From what has been said as to the state of mechanical strain into which the dielectric of a condenser is thrown when charged with electricity (787), it is not difficult to account for the phenomenon of the residual charge. An elastic body, such as a steel plate, which has been twisted or bent, reverts to its original state when the stress which brought about the deformation ceases to act, but not at once quite completely. A certain length of time is required for this alteration to take place, but the change is promoted by any gentle mechanical action, such as tapping, which gives the molecules a certain freedom of motion. Dr. Hopkinson made an experiment with a Leyden jar which is quite analogous to this. A glass vessel (fig. 770) contains sulphuric acid, and in it is placed a thinner

one, about half full of the same liquid. Platinum wires dip in the two liquids, one of them being in connection with the prime conductor of an electric machine, while the other is connected with the earth. The arrangement forms, in short, a condenser, the coatings of which are sulphuric acid. When, after being thus charged, the jar is discharged, a residual discharge may be taken after some time by again connecting the wires; if, however, the inner jar is gently tapped with a piece of wood, the residue makes its appearance much more rapidly.

790. **Electric batteries.**—The charge which a Leyden jar can take depends on the extent of the coated surface, and is inversely proportional to the thickness of the insulator. Hence, the larger and thinner the jar the greater the capacity and the more powerful the charge, for a source of given potential. But very large jars are expensive, and liable to break; and when too thin, the accumulated electricities discharge themselves through the glass, especially if it is not quite homogeneous. Leyden jars have usually from $\frac{1}{2}$ to 3 square feet of coated surface. For more powerful charges electric batteries are used.

An *electric battery* consists of a number of Leyden jars whose internal and external coatings are respectively connected with each other (fig. 771). They are usually placed in a wooden box lined on the bottom with tinfoil, which is connected with two metal handles in the sides of the box. The

inner coatings are connected with each other by metal rods, which, when the battery is to be charged, are connected with the prime conductor, while the outer coatings are connected with the ground by means of a chain fixed to the handles.

A Henley's electro-scope (fig. 771) indicates the charge of the battery. The larger and more numerous the jars

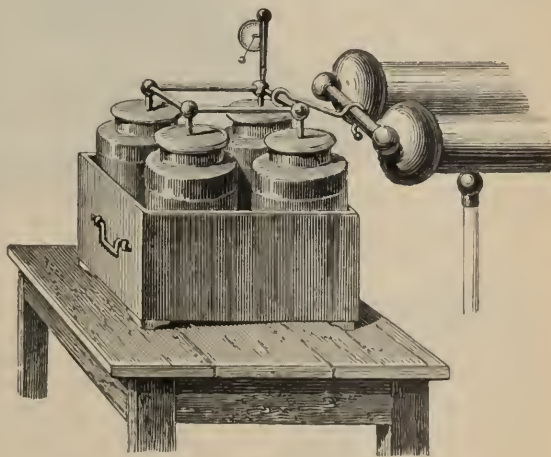

Fig. 771

the longer is the time required to charge the battery, but the effects are so much the more powerful (801).

To discharge a battery we must connect the coatings by means of the discharging rod, the outside coating being touched first. Care is required, for with large batteries serious and even fatal accidents may occur.

791. **The universal discharger.**—This is an almost indispensable apparatus in experiments with the electric battery. On a wooden stand (fig. 772) are two glass pillars provided at the top with universal joints, in which movable brass rods are fitted. Between these pillars is a small ivory table,

on which is placed the object under experiment. The two metal knobs being directed towards the objects, one of them is connected with the outer coating of the battery, and the moment communication is made between the outer and the inner coating by means of the glass discharging rod, the discharge passes through the object on the table.

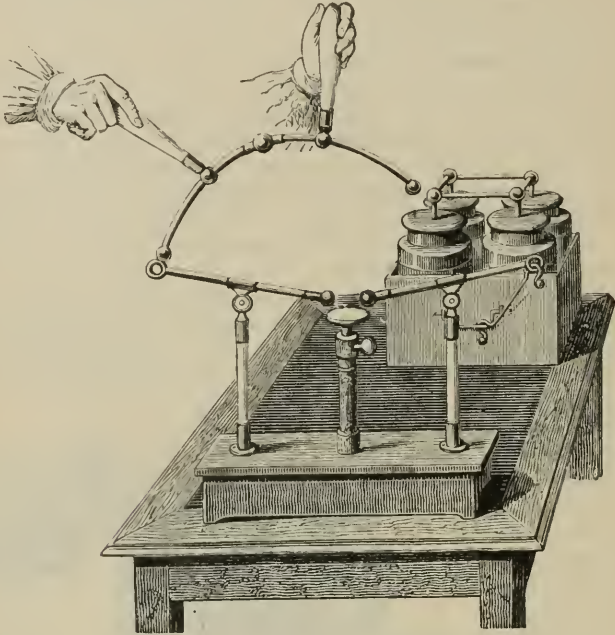

Fig. 772

792. **Charging Leyden jars in series or cascade.**—A number of Leyden jars are placed each on a separate insulating support. The knob of the first, ϕ (fig. 773), is in connection with the prime conductor of the machine, and its outer coating joined to the knob of the second, the outer coating of the second to the knob of the third, and so on, the outer coating of the last,

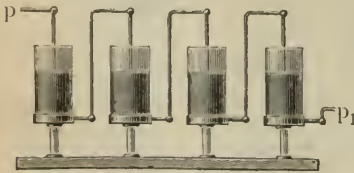

Fig. 773

ϕ_1 , communicating with the ground. The inner coating of the first receives a charge of positive electricity from the machine, and the corresponding positive electricity set free by induction on its outer coating, instead of escaping to the ground, passes to the inner coating of the second, which, acting in like manner, develops a charge in the third jar, and so on to the last, where the positive electricity developed

by induction on the outer coating passes to the ground. The jars may be discharged either singly by connecting the inner and outer coatings of each

jar, or simultaneously by connecting the inner coating of the first with the outer of the last. In this way the quantity of electricity necessary to charge one jar is available for charging a series of jars.

It must not be supposed, however, that each jar contains as much electricity as a single jar would if charged in the usual way to the same potential of the machine. Suppose there are four similar jars, each of capacity C , and that the machine is worked until its potential rises to V , which may be indicated by a deflection of (say) 30° of a Henley's electroscope (748). In the case where a single jar is charged by itself, the drop of potential between the inner and outer coatings is V , since the outer coating is earthed; but when four jars are arranged in cascade, the same drop takes place in four stages, and the difference of potential between the inner and outer coatings of any one of the jars is $V/4$. The quantity in any one jar is $CV/4$, and the sum in the four jars CV , which is exactly equal to the quantity any one of the jars would have had, had it been charged by itself to the potential indicated by the electroscope.

793. **Measurement of the charge of a battery.** Lane's electrometer.—When the outer and inner coatings of a charged Leyden jar are gradually brought near each other, at a certain distance a discharge ensues. The distance is called the *striking or sparking distance*. For the same charge it is inversely proportional to the pressure of the air, and, with the same jar, but different charges, directly proportional to the electric density of that point of the inner coating at which the discharge takes place. As the density of any point of the inner coating, other things remaining the same, is proportional to the entire charge, the striking distance is proportional to the quantity of electricity in a jar. The measurement of the charge of a battery, however, by means of the striking distance, can only take place when the charge disappears.

By means of Lane's electrometer, which depends on an application of this principle, the charge put into a jar or battery may be measured. This apparatus, c (fig. 774), consists of an ordinary Leyden jar, near which there is a vertical metallic support. At the upper end is a brass rod, with a knob at one end, which can be placed in metallic connection with the outside of the jar: the rod being movable, the knob can be kept at a measured distance from the knob of the inner coating, such as to ensure that a comparatively small difference of potential between the two coatings will give rise to a spark and so discharge the jar. Fig. 774 represents the operation of measuring the charge of a jar or battery by means of this apparatus.

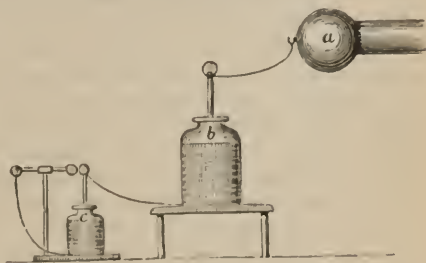

Fig. 774

The jar b , whose charge is to be measured, is placed on an insulated stool with its outer coating in metallic connection with the inner coating of Lane's jar c , the outer coating of which is put to earth; a is the conductor of the machine. When the machine is worked, positive electricity passes into the

jar or battery *b*, and from the outer coating of *b* into *c*. When the charge in *c* has reached a certain limit, it discharges itself between the two knobs, and as often as such a discharge takes place, the same quantity of positive electricity will have passed from the machine into the battery; hence its charge is proportional to the number of discharges of the electrometer.

794. **Harris's unit jar.**—Harris's unit jar (fig. 775) is an application of the same principle, and is often convenient for measuring quantities of electricity. It consists of a small Leyden phial, 4 inches in length and $\frac{3}{4}$ inch in diameter, coated to about an inch from the end, so as to expose about 6 inches of coated surface. It is fixed horizontally on a long insulator, and the charging rod connected at *P* with the conductor of the machine, while the outer coating is connected with the jar or battery by the rod *tp*.

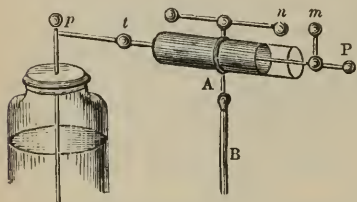

Fig. 775

When the charge of electricity in the interior has reached a certain potential depending on the distance of the two balls *m* and *n*, a discharge ensues, and marks a certain quantity of electricity received as a charge by the battery, in terms of the charge of the small jar.

795. **Volta's condensing electroscope.**—The condensing electroscope invented by Volta is a modification of the ordinary gold-leaf electroscope (748). The rod to which the gold-leaves are affixed terminates in a disc instead of in a knob, and there is another disc of the same size provided with an insulating glass handle. The discs, which are covered with a layer of insulating shellac varnish (fig. 776), form a condenser, with air and shellac as the dielectric.

By this association of a condenser with the gold leaf electroscope, differences of potential may be indicated, and roughly measured, too small to be shown by the unaided electroscope. Suppose, for instance, we wish to measure the difference of potential between the poles of an insulated voltaic battery. Let wires, connected to the poles and held by insulating tongs, be brought into contact with the upper and lower plates, the positive pole (say) with the upper plate, and the negative with the lower. The plates will become charged with positive and negative electricity respectively, and the difference of potential between them will be that which we wish to measure, but there will be no divergence of the leaves. Now let the wires be carefully detached and the upper plate removed by its glass handle; the leaves at once diverge with negative electricity, which was set free by the removal of the upper plate. Indeed, when the upper plate was removed, the electrostatic capacity of the electroscope was very much reduced; and, as the charge of negative electricity on it was not altered, its potential rose in the same proportion as its capacity fell, and became sufficiently large to cause a deflection of the leaves. If the lower plate is connected with the positive pole, and the upper with the negative, and the same operations are repeated, the leaves will diverge to the same extent as before, but with positive electricity.

With his condensing electroscope Volta showed that if strips of zinc and copper are soldered together, they become oppositely electrified. The zinc was held in the hand, and the lower plate touched with the copper, while the upper plate was touched with the finger. On removal of strip and upper plate, the leaves diverged with negative electricity (813).



Fig. 776



Fig. 777

796. **Quadrant electrometer.**—Lord Kelvin devised a very sensitive electrometer by which accurate measurements of potential may be made. One form of this instrument, represented in fig. 778, consists of two pairs of quadrants, AA' , BB' , of thin sheet metal, which together form a flat cylindrical box, cut into four quadrants by diametral sections at right angles to each other. Each of these quadrants is suspended to the top of the case by a glass stem, and the alternate pairs are connected with each other by wires. Each of the pairs is also connected with an insulated binding screw, so that connection can be made with bodies on the outside.

In the middle of the quadrant is hung, by a bifilar suspension, what is called the *needle*, which consists of a thin sheet of aluminium shaped as shown in fig. 779; for the sake of lightness, parts of the needle are cut out.

If all the quadrants are in the same electric condition, the adjustment is made so that the two fibres of the suspension are in the same plane which is symmetrical with reference to the space between the quadrants. If now the two pairs of quadrants are at different potentials, as when, for instance, they are connected with the two poles of a voltaic cell by means of the binding screws, and if the needle is charged to a given potential, which is usually positive and much higher than that of either pair of quadrants

one end of the needle will be repelled by the pair of quadrants which are electrified like itself and will be attracted by the other pair. It will thus be subject to the action of a couple tending to set it obliquely to the slit. In order to render the slightest motion of the needle visible, a small

silver concave mirror with a radius of about a metre is connected with it. The light of a petroleum lamp, not represented in the figure, strikes against this, and is reflected as a spot on a horizontal scale. Any deflection of the needle, either on one side or the other, is indicated by the motion of the spot of light on the scale (532).

In order that the potential of the needle may be kept as constant as possible, a platinum wire attached to the needle dips into a glass vessel containing strong sulphuric

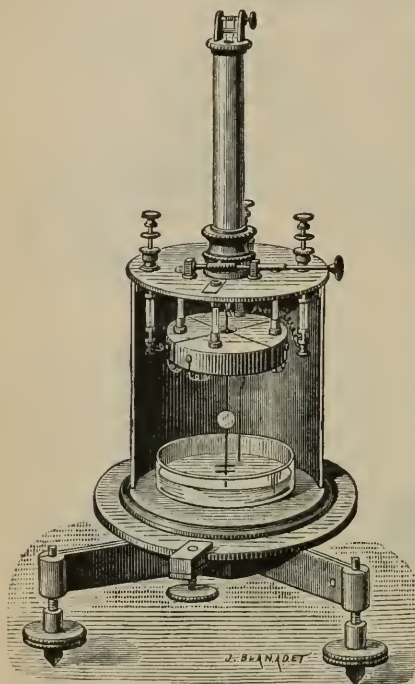

Fig. 778

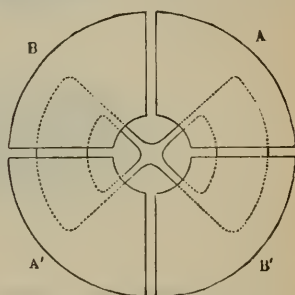

Fig. 779

acid, and coated externally with tinfoil. The sulphuric acid keeps the electrometer dry, and acts as the inner coating of a Leyden jar, the tinfoil outer coating being uninsulated. When the jar is charged the needle will have the same potential as the sulphuric acid, and the leakage will be slow. The more complete forms of instrument are provided with a *replenisher* (774), whereby the potential of the jar and needle can be brought to any required value, and also a subsidiary electrometer (the *gauge*) which shows when the right value is attained.

If A and B represent the potentials of the quadrants, and C the potential of the needle, it may be proved that $d = k(A - B) \left(C - \frac{A + B}{2} \right)$, where d is the deflection of the needle, and k a constant depending on the instrument. The Leyden jar of the electrometer is generally charged by two or three sparks from an electrophorus, and is thus raised to a potential of some hundreds (or even thousands) of volts. If, in comparison with C, A and B are small, we may neglect $(A + B)/2$ in comparison with C, and the formula

becomes $d = k(A - B)C$. Hence, if C can be kept constant by a replenisher, the deflection of the needle is directly proportional to the difference of potential between the quadrants.

797. **Thomson's absolute electrometer.**—Another class of electrometers, also invented by Lord Kelvin, give a direct measure of electric constants in absolute measure. Fig. 780 represents a modified form of the electrometer for class experiments.

Two plane metal discs A and B , about 10 cm. in diameter, are kept at a distance from each other, which is small in proportion to their diameters, but which can be very accurately measured. Out of the centre of the upper one is cut a disc c ; this is suspended by insulating threads from one end of the arm ab of a balance, at the other end of which is a counterpoise, or a scalepan p . At the end of the arm is a fork, across which is stretched a fine wire; when the disc is exactly in the plane of the circular band or ring which surrounds it, which is called the *guard ring*, this fine wire is exactly across the interval between two marks in the upright, and its position can be accurately determined by means of the lens C . The disc and the guard ring are in contact with each other by means of a bridge of very fine wire (not shown in the figure), and are kept at a constant potential, being connected by a wire with a constant source of electricity, while the plate B can be kept at any potential or put to earth.

Suppose now that the whole system is at the same potential, and that the disc is exactly balanced so as to be in the plane of the guard ring. If now A is electrified to a given potential, while the plate B is connected with the earth, c will be attracted

towards B ; and in order to retain it exactly in the plane of the guard ring the force applied at the other end of the lever must be increased. This may be done by altering the distance of the counterpoise, or by adding weights to a scalepan, and the additional weight thus applied is a measure of the attractive force.

By reason of the guard ring the electric field between c and B will be uniform, the lines of force being straight, uniformly spaced, and perpendicular to the plates. If σ is the electric density on c , and S its area, $S\sigma$ will be its charge, and $2\pi\sigma^2S$ the force with which it is urged downwards, and which must be balanced by weights in the pan p . If F is this force, $F = 2\pi\sigma^2S$. This force can be measured as explained above, and from the result we have to deduce the difference of potentials between the two discs A and B . Calling the potential of the former V , that of the latter V' , and d the distance between the plates, we may write

$$V - V' = fd$$



Fig. 780

if f_1 stands for the force which would be exerted upon a unit of positive electricity anywhere between the plates. In words, this equation is a statement that the difference of potentials is equal to the work that must be done against electric force to carry a unit of positive electricity from plate B to plate A (758). The force f is made up of a repulsion $2\pi\sigma$ due to the plate A, and an attraction $2\pi\sigma$ due to the plate B, or, altogether, $f=4\pi\sigma$ (756). Consequently

$$V - V' = 4\pi\sigma d;$$

but, as has been already proved, $2\pi\sigma^2 S = F$, or $\sigma = \sqrt{\frac{F}{2\pi S}}$.

Hence
$$V - V' = 4\pi d \sqrt{\frac{F}{2\pi S}} = d \sqrt{\frac{8\pi F}{S}}.$$

If the disc c is circular and its radius is a , we have $S = \pi a^2$, and the difference of potentials is given by the very simple formula

$$V - V' = \frac{d}{a} \sqrt{8F}.$$

It is also clear that the experiment may be modified by making F constant and the distance variable. By means of micrometric arrangements the distance of the plates may be varied and measured with very great accuracy. This principle is applied in a portable form of this electrometer.

798. **Electrostatic voltmeters.**—A modification of Lord Kelvin's quadrant electrometer, called an *electrostatic voltmeter*, is used when we wish to measure differences of potential of hundreds or thousands of volts. Only

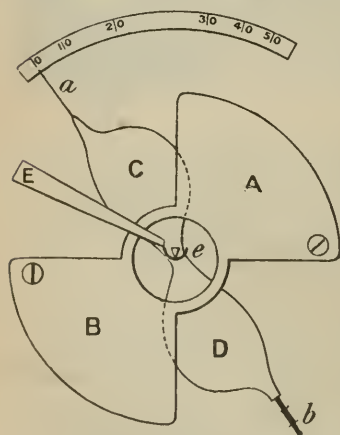

Fig. 781

two quadrants, A and B, of a cylindrical box are used, and are arranged as shown in fig. 781, the paddle-shaped aluminium needle being pivoted to move about a central horizontal axis in and out of the quadrantal spaces, its position being controlled by weights hung at the lower end. When there is a difference of potential between needle and quadrants the needle is attracted and its pointer moves over a graduated scale, the attraction varying as the square of the difference of potential. The scale is graduated empirically, in volts, and various degrees of sensitiveness are obtained by attaching different weights to b .

Another type of electrostatic voltmeter, called a *zero electrostatic voltmeter*, designed by Professor Ayrton and Mr. Mather, is illustrated in fig. 782. Its action depends on the measurement of the attraction of two electrified conductors, which are charged to the difference of potential under investigation, by the torsion

of a wire. Two narrow strips of aluminium, *aa* (figs. 782 and 783), are joined together at top and bottom by cross-pieces, *bb*, and the frame or *needle* so formed suspended from a torsion head H by a thin narrow strip of phosphor-bronze. An index C, attached to the torsion head, moves over a graduated dial, and indicates the torsion applied to the upper end of

the suspension-strip. The conductors, I I, called the *inductors*, by which *aa* are attracted, are shaped as shown, and by means of a pointer *p*, carried from the bottom of the needle, the position of the needle can be observed. Parallax is avoided

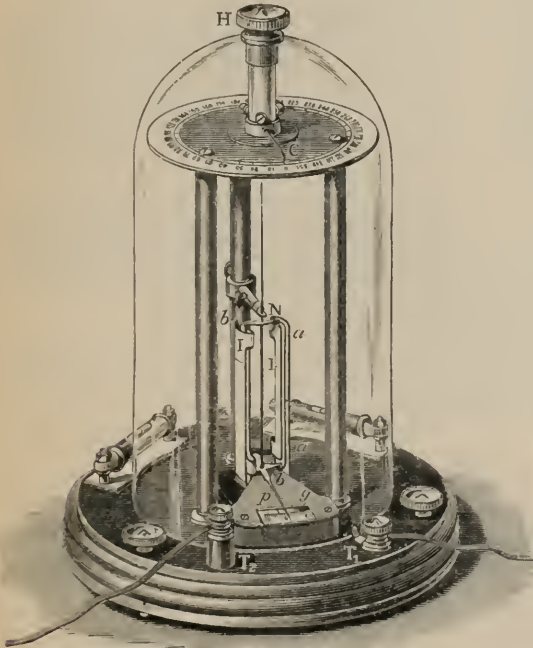

Fig. 782

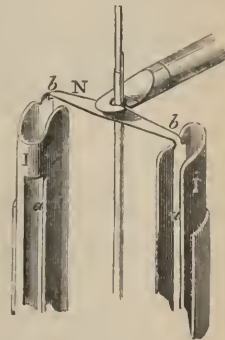

Fig. 783

by observing the reflection of this pointer in a piece of looking-glass, *g*, fixed to the base of the instrument. Any difference of potential set up between the needle and the inductors is measured by turning the torsion head H until the pointer *p* is brought into the same position it occupied when the needle and inductors had the same potential. The square root of the angle through which C has been turned measures the difference of potential between the needle and inductors, that is, between bodies connected respectively to the terminals T_1 and T_2 .

799. **Potential and capacity of a condenser.**—These may be most conveniently investigated by considering the case of a spherical jar. Let us suppose A (fig. 784) to represent an isolated metal sphere of radius R , and let us consider it placed in conducting communication with a source of constant potential V . Then its potential V is $\frac{q}{R}$, its charge $q = VR$, and the ratio of charge to potential, or the capacity of the sphere, is R .

Suppose now this sphere to be surrounded by a concentric conducting

shell or envelope B, which is in connection with the earth, then from the inductive action set up, there will now be two electric layers—one on the sphere A, and the other on the inner surface of the sphere B. These will be equal and of opposite sign; let them be $+Q$ and $-Q$.

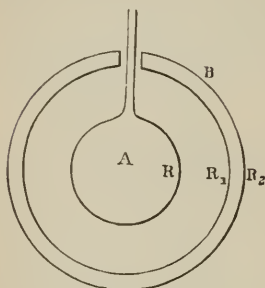

Fig. 784

The sphere A, being still connected with the source, has the potential V , but its present charge Q is greater than the charge q which produced the same potential when it was isolated. In the present case, the potential is $V = \frac{Q}{R} - \frac{Q}{R_1}$ (758), where the first term on

the right is the potential at the centre due to the charge Q of the sphere A taken by itself, and the second term is the potential at the centre due to the charge $-Q$ of the surrounding shell. The charge Q is consequently $= V \frac{RR_1}{R_1 - R}$, and the capacity is now $\frac{Q}{V} = \frac{RR_1}{R_1 - R}$.

Suppose that the distance $R_1 - R$ between the two coatings of the condenser is constant and equal to t , while the radii, R, R_1 , increase indefinitely. The capacity per unit area of the sphere whose radius is R

$$= \frac{1}{4\pi R^2} \cdot \frac{RR_1}{t} = \frac{1}{4\pi t} \cdot \frac{R_1}{R}$$

When R and R_1 are indefinitely large their ratio is equal to unity, and the surfaces of the spheres become plane; hence the capacity per unit area of an air-plate condenser $= \frac{1}{4\pi t}$. If S is the area of either plate, the capacity is $\frac{S}{4\pi t}$.

If instead of air there is a solid or liquid dielectric, whose specific inductive capacity is κ , the formula becomes $Q = \frac{VS\kappa}{4\pi t}$. If the dielectric be partly air and partly some other material, such as glass, then if the thickness of this latter is θ , $Q = \frac{VS}{4\pi(t - \theta + \theta/\kappa)}$. The expression $\frac{\theta}{\kappa}$ is sometimes

written t' , and represents the thickness of the layer of air equivalent to it in specific inductive capacity. It is also called the *reduced thickness*.

Thus, suppose a sphere to have a radius $R = 10$ cm., and to be surrounded by an earth-connected metal shell of radius $R_1 = 10.2$ cm., then the thickness of the dielectric (assumed to be air) is 0.2 and the capacity of this condenser is 510, or 51 times as great as that of the insulated sphere R .

The formula obtained above for the capacity of a spherical condenser with spheres of nearly equal radius, namely $\frac{S\kappa}{4\pi t}$, applies to any condenser formed, like a Leyden jar, of a thin uniform layer of adielectric between two parallel conducting surfaces.

If R_1 is so great that the value of R in the denominator of the expression for the capacity of two concentric spheres may be disregarded, we get $C = R$, which is the expression for the capacity of an isolated sphere (760); such a sphere may be regarded as a condenser, in which the layer of air, between it and the sides of the room, represents the dielectric.

When n identical Leyden jars are joined in surface or in parallel we have a condenser whose capacity is equal to the n -fold capacity of a single jar. If these n jars are joined in cascade or in series, the capacity of the system is that of a single jar, the dielectric of which is n times as thick, that is, is the $1/n$ th part of the capacity of such jar.

Generally, if $C_1, C_2, C_3 \dots$ are the separate capacities of a number of Leyden jars arranged in series as in fig. 773, and C be the resultant capacity,

$$1/C = 1/C_1 + 1/C_2 + 1/C_3 + \&c.$$

This relation may be proved as follows:—Let $V_1, V_2, V_3 \dots$ be the differences of potential between the outer and inner coatings of the successive jars, and V the potential of the machine. Since the quantities of electricity which go to charge the several jars are equal, each of them

$$= Q = C_1 V_1 = C_2 V_2 = C_3 V_3 = \&c. = CV$$

$$\text{and } V = V_1 + V_2 + V_3 + \&c.$$

$$\therefore \frac{Q}{C} = \frac{Q}{C_1} + \frac{Q}{C_2} + \frac{Q}{C_3} + \dots$$

$$\text{or } \frac{1}{C} = \frac{1}{C_1} + \frac{1}{C_2} + \frac{1}{C_3} + \dots$$

800. Effects of the electric discharge.—The recombination of the two electricities which constitutes the electric discharge may be either continuous or sudden: *continuous*, or of the nature of a current, as when the two conductors of a Holtz's machine are joined by a chain or a wire; and *sudden* or *disruptive*, as when the opposite electricities accumulate on the surface of two adjacent conductors, till their mutual attraction is strong enough to overcome the intervening resistances, whatever they may be. But the difference between a sudden and a continuous discharge is one of degree, and not of kind, for there is no such thing as an absolute non-conductor, and the very best conductors, the metals, offer an appreciable resistance to the passage of electricity. Still the difference at the two extremes of the scale is sufficiently great to give rise to a wide range of phenomena.

Riess showed that the discharge of a battery does not consist in a simple union of the positive with the negative electricity, but that it consists of a series of successive partial discharges. The direction of the discharge depends mainly on the length and nature of the circuit.

Feddersen examined the discharge of a Leyden jar by the arrangement represented in fig. 785, in which the spark of the Leyden jar passes between the knobs a and b . On the axis xx , which by means of clockwork is rotated at a known and uniform rate, are two long-focus concave mirrors, d and e ; to the axis is also attached a brass strip, the ends of which, f and g , just touch the bare ends of the insulated wires at the moment the spark passes between a and b ; at this instant the spark is in the same vertical plane as the

principal axis of the mirror. The image of the spark is reflected on the ground-glass plate *h*.

Observed in this manner the spark is seen as a narrow band of light, the length of which varied with the duration of the discharge. The duration was found to increase with the striking distance, and with the number of jars.

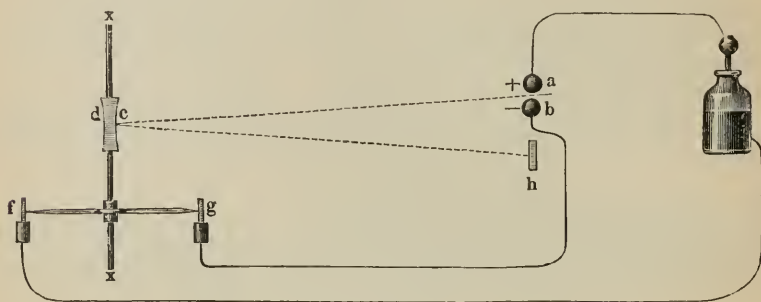

Fig. 785

When the resistance of the circuit between the outer and inner coatings was small, it was found that the discharge was an *oscillatory* one, consisting of a series of separate discharges in alternating directions; the image was traversed by a number of dark lines. With a greater resistance the discharge was a single *continuous* one, and its image was that of a continuous band of light. With very great resistance the discharge was an *intermittent* one, and consisted of sparks following each other at irregular intervals.

Mr. C. V. Boys in 1890 photographed the discharge of a Leyden jar by means of a rapidly revolving lens, and showed that if the discharge circuit has a sufficiently low resistance the discharge consists of a series of separate discharges, each of which leaves a separate impression on the photographic plate.

More recently Professor Trowbridge charged a condenser by means of storage cells giving an electromotive force of 20,000 volts. By arranging the condensers in parallel during charge, and by discharging them in series through a circuit containing self-induction (967), he obtained spark discharges 6 feet in length, corresponding to a difference of potential of 3×10^6 volts. These long sparks are oscillatory.

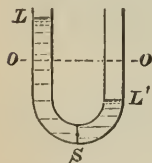

Fig. 786

These oscillatory discharges may be illustrated by means of a simple hydrostatical experiment. Suppose that in the U-tube (fig. 786) there is a valve, *S*, by which the two branches are separated, and that water is poured in one so that it is at the height $+L$ above the level *OO*, and in the other in the corresponding distance $-L'$ below the level. When the valve is suddenly opened, the water passes through, and only comes to rest in the position *OO* after several oscillations about this level. Suppose the valve to be suddenly closed during the oscillation, it may easily happen that the water is higher in that limb in which it was previously lower. This would represent the

case observed by Oettingen with the residual charges of condensers, which he found to be sometimes negative and sometimes positive.

Again, if the valve is only slightly opened so that great resistance is offered, the water slowly sinks to its level, the discharge is continuous, and there are no oscillations ; this corresponds to the case in which the electric resistance is very great.

We may further compare the dielectric in a state of strain, like the glass of a charged Leyden jar, to a straight steel band, clamped at one end ; if the free end is pulled aside, the plate is in a state of strain, and when this strain is removed the plate comes to rest after making a series of oscillations. To prevent these oscillations the plate must be exposed to a great resistance, by being placed, for instance, in a viscous liquid ; in like manner, as we have seen, by offering a great resistance to the electric discharge, it becomes continuous. The rate of vibration of a steel plate or a stretched string depends on its elasticity and on its moment of inertia. In like manner the period of oscillation of an electric discharge depends on the self-induction (967) and electrostatic capacity of the circuit.

The oscillatory nature of the discharge has been confirmed by the observations of Paalzow on the luminous phenomena seen in highly rarefied gases when it takes place in them, as well as by the manner in which a magnet affects the phenomena. Von Helmholtz had already inferred the necessity of such an oscillating motion from the laws of the conservation of energy, and Lord Kelvin and Kirchhoff deduced the conditions under which it occurs. Lord Kelvin showed as long ago as 1851 that, when a condenser of capacity C is discharged through a circuit of self-induction L and resistance R , there will be oscillations in the circuit if R^2 is less than $4L/C$, and further that if R is small, the period of oscillation = $2\pi\sqrt{LC}$.

801. **Work done by the discharge of a Leyden jar.**—The potential V of a conductor is the work which must be done upon the unit charge of positive electricity to carry it from the earth to the conductor, the potential of the latter not being altered thereby ; if Q units are carried, the work done is QV . But in charging any conductor or condenser, the potential is zero at first, and rises gradually to V ; its mean value during the process of charging is $\frac{V}{2}$. Hence the work, W , done in charging is $\frac{1}{2}QV$. In the case

of a Leyden jar, since $Q = VC$, $W = \frac{1}{2}QV = \frac{CV^2}{2} = \frac{Q^2}{2C} = \frac{1}{2} \frac{S}{4\pi t} V^2$; that is, is proportional to the surface and to the square of the potential, and is inversely as the *reduced* thickness of the insulator. From the principle of the conservation of energy, this stored-up energy reappears when the jar is discharged. It shows itself partly in the form of a spark, partly in the heating effect of the whole system of conductors through which the discharge takes place. When the armatures are connected by a thick short wire, the spark is strong and the heating effect small ; if, on the contrary, the jar is discharged through a long fine wire, this becomes more heated, but the spark is weaker.

If a number of identical jars are each separately charged from the same source, they will each acquire the same potential, which will not be altered

if all the jars are connected by their inner and outer coatings respectively. The total charge will be the same as if the battery had been charged directly from the source, and its energy will be $W = \frac{1}{2}Vnq = \frac{1}{2}VQ$; that is, the energy of a battery of n equal jars is the same as that of a single jar of the same thickness but of n times the surface.

Let us consider two similar Leyden jars having respectively the capacities c and c' ; let one of them be charged to potential V , and let the other remain uncharged. Suppose now that the inner and outer coatings of the jars are respectively connected with each other. Then the energy of the charged jar alone is $W = \frac{1}{2} \frac{Q^2}{c}$, and when it is connected with the other, the original charge will spread itself over the two, so that the energy of the charge in the two jars is $W' = \frac{Q^2}{2(c+c')}$. Hence $W : W' = c + c' : c$; and therefore, since $c + c'$ is always greater than c , there must be a loss of energy. In point of fact, when a charged jar is connected with an uncharged one, energy is lost in the spark and in the heat developed in the connecting wire. It follows, further, that when two jars at different potentials are united there is always a loss of energy.

If a series of n similar jars are joined in parallel, and a given charge of electricity is imparted to them, the energy is inversely as the number of jars; but, when charged from a source of constant potential, the energy is proportional to the number of jars. If, however, the jars are arranged in cascade, then for a given charge the energy is n times that of a single jar, while for a given potential it is n times smaller. It is sometimes convenient to arrange the jars in a combination of the two systems.

802. Physiological effects.—The shock from the electric machine has been already noticed (778). The shock taken from a charged Leyden jar by grasping the outer coating with one hand and touching the inner with the other is much more violent, and has a peculiar character. With a small jar the shock is felt in the elbow; with a jar of about a quart capacity it is felt across the chest, and with jars of still larger dimensions in the stomach.

A shock may be given to a large number of persons simultaneously by means of a Leyden jar. For this purpose they must form a chain by joining hands. If, then, the first touches the outside coating of a charged jar, while the last at the same time touches the knob, all receive a simultaneous shock, the intensity of which depends on the charge, and on the number of persons receiving it. Those in the centre of the chain are found to receive a less violent shock than those near the extremities.

With large Leyden jars and batteries the shock is sometimes very dangerous. Priestley killed rats with batteries of 7 square feet coated surface, and cats with a battery of about $4\frac{1}{2}$ square yards coating.

Experience shows that the physiological effect depends upon both the quantity and potential, either of which may be large without producing disagreeable effects provided the other is small; thus a discharge from an ordinary electric machine which gives a spark of nearly a foot may be taken without danger, while one of a few millimetres from a battery of large capacity could not be borne. The duration of the discharge has also an influence; a battery which gives a violent shock when discharged in

ordinary conditions gives but a feeble one when discharged through a moist string, which only diminishes the rapidity of the discharge.

803. **Luminous effects.**—The recombination of two electricities of high potential (760) is always accompanied by a disengagement of light, as is seen when sparks are taken from a machine, or when a Leyden jar is discharged. The better the conductors on which the electricities are accumulated, the more brilliant is the spark ; its colour varies not only with the nature of the bodies, but also with the nature of the surrounding medium and with the pressure. The spark between two charcoal points is yellow, between two balls of silvered copper it is green, between knobs of wood or ivory it is crimson. In air at the ordinary pressure the electric spark is white and brilliant ; in rarefied air it is reddish ; and *in vacuo* it is violet. In oxygen, as in air, the spark is white ; it is reddish in hydrogen, and green in the vapour of mercury ; in carbonic acid it is also green, while in nitrogen it is blue or purple, and accompanied by a peculiar sound. In general, the higher the potential the greater is the lustre of the spark.

When these sparks are examined by the spectroscope (587) they show the lines characteristic of the metals between which the spark passes, and also of the gas in which it takes place. If the knobs are of different metals the lines of both are seen. Part of the energy is accordingly consumed in detaching and volatilising the metal particles on the two electrodes ; when a powerful discharge takes place between a knob of gold and one of silver, some of the latter metal is found on the gold knob, while some gold also is found on the silver knob. This is a direct proof that the discharge is an oscillatory one (800).

804. **Spark and brush discharge.**—The shapes which luminous electric phenomena assume may be classed under two heads—the *spark* and the *brush*. The brush forms when the electricity leaves the conductor in a continuous flow ; the spark, when the discharge is discontinuous. The formation of one or the other depends on the nature of the conductor and of the conductors in its vicinity ; and small alterations in the position of the surrounding conductors transform the one into the other.

The spark which at short distances appears straight at longer distances has an irregular shape with diverging branches. Its length depends on the difference of potential, and on the size and shape of the conductors between which it passes. With long sparks the luminosity is different in different parts of the spark.

The brush derives its name from the radiating divergent arrangement of the light, and presents the appearance of a luminous cone, whose apex touches the conductor. Its size and colour differ with the nature and form of the conductor ; it is accompanied by a peculiar hissing noise, very different from the sharp crack of the spark. Its luminosity is far less than that of the spark ; for while the latter can easily be seen by daylight, the former is only visible in a darkened room. The brush discharge may be obtained by placing on the conductor a wire filed round at the end, or, with a powerful machine, by placing a small bullet on the conductor. The brush from a negative conductor is less than from a positive conductor ; the cause of this difference has not been satisfactorily made out, but it may originate in the fact, which Faraday has observed, that negative electricity

discharges into the air at a somewhat lower potential than positive electricity ; so that a negatively charged knob sooner attains that potential at which spontaneous discharge takes place than does a positively charged one, and therefore discharges the electricity at smaller intervals and in less quantities.

When electricity, in virtue of its high electrostatic pressure, issues from a conductor, no other conductor being near, the discharge takes place without noise, and at the places at which it appears there is a pale blue luminosity called the *electric glow*, or on points a star-like centre of light. It is seen in the dark by placing a point on the conductor of the machine. It may be regarded as a very short brush.

805. **Striking distance.**—Sir W. Harris by means of his unit jar, and Riess by independent researches, found that for small distances the striking

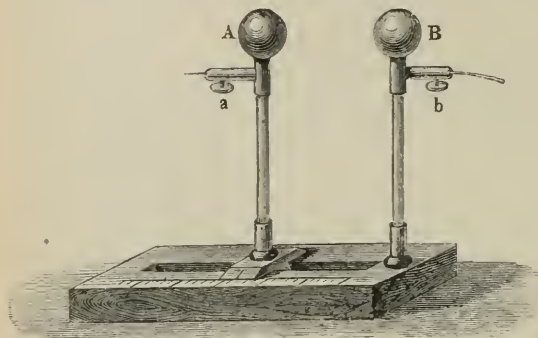

Fig. 787

distance is directly proportional to the quantity of electricity, and inversely proportional to the coated surface ; in other words, it is proportional to the potential. For his experiments Riess used the *spark micrometer*, which consists of two metal knobs, A and B (fig. 787), provided with binding screws, a and b, and on insulating supports, the

distance of which from each other could be varied by a micrometric screw.

The striking distance varies slightly with the shape of the electrodes ; thus for the same distance the difference of potential required is slightly greater for two spheres than for two plates.

The high temperature and short duration of the spark produce a sudden expansion of the air through which it passes, and a compression of the surrounding air. Hence a wave of compression starts from the path of the spark which produces the sound.

For greater distances the difference of potential increases less rapidly than the distance, and the greater the distance the less is the rate of increase ; this is seen from the following table. In the experiments the discharging knots were 2·2 cm. in diameter.

Distance	Volts	Distance	Volts
cm.		cm.	
0·1	5,490	5·0	94,800
0·5	26,730	7·0	107,700
1·0	48,600	10·0	119,100
2·0	64,800	12·0	124,200
3·0	76,800	15·0	127,800

It appears that for very short sparks there is a certain critical spark-length below which the difference of potential increases as the spark-length diminishes. About 350 volts is the smallest difference of potential which can produce a spark in air under ordinary conditions.

The influence of pressure on the electric discharge may be studied by means of the *electric egg*. This consists of an ellipsoidal glass vessel (fig. 788) with metal caps at each end. The lower cap is provided with a stopcock, so that it can be screwed into an air-pump, and also into a heavy metallic foot. The upper metal rod moves up and down in a leather stuffing-box; the lower one is fixed to the cap. The vessel having been exhausted as far as possible, the stopcock is turned, and the vessel screwed into its foot; the upper part is then connected with a powerful electric machine, and the lower one with the ground. On working the machine, the globe becomes filled with a feeble violet light continuous from one end to the other. If the air is gradually allowed to enter by opening the stopcock, the light now appears white and brilliant, and is only seen as an ordinary intermittent spark.

If by means of such an apparatus the pressure of the air is gradually increased, the striking distance is diminished, and with a pressure of 50 atmospheres the discharge of even a powerful machine is stopped.

Hertz showed that disruption discharge between two conductors may be facilitated by exposing the air through which the discharge takes place to ultra-violet light. The seat of this action is at the surface of the negative terminal. The best pressure is about 300 mm.

806. **Heating effects.**—Besides being luminous, the electric spark is a source of great heat. When it passes through inflammable liquids, as ether or alcohol, it inflames them. An arrangement for effecting this is represented in fig. 789. It is a small glass cup through the bottom of which passes a metal rod, terminating in a knob and fixed to a metal foot. A quantity of liquid sufficient to cover the knob is placed in the vessel. The outer coating of the jar having been connected with the foot by means of a chain, the spark which passes when the two knobs are brought near each other inflames the liquid. With ether the experiment succeeds very well, but alcohol requires to be first warmed.

Coal gas may also be ignited by means of the electric spark. A person standing on an insulated stool places one hand on the conductor of a machine,



Fig. 788

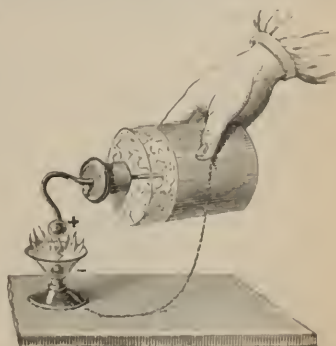

Fig. 789

which is then worked, while he presents the other to the jet of gas issuing from a metallic burner. The spark which passes ignites the gas. When a battery is discharged through an iron or steel wire, the latter becomes heated, and is even made incandescent or melted if the discharge is very powerful.

The laws of this heating effect were investigated independently by Harris and by Riess by means of the *electric thermometer*.

In its later forms as modified by Riess, this consists of a glass bulb (fig. 790), closed by a stopper, *c*, and attached to a capillary tube which is bent twice, and terminates in an enlargement; this contains coloured liquid. The whole apparatus is fixed on a hinged support, *A*, which works on the base *B*, so that it can be inclined and fixed at any given

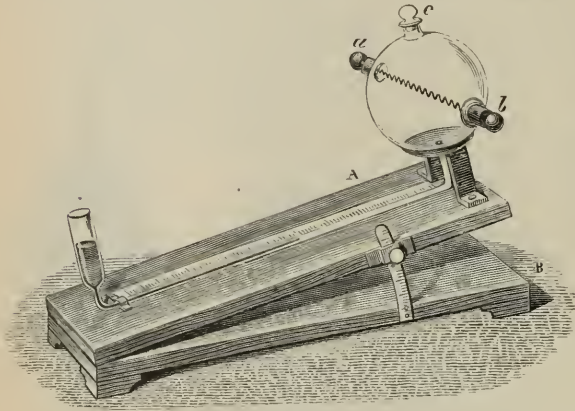

Fig. 790

angle. The diameter of the tube being very small compared with that of the enlargement, a considerable displacement of the liquid may take place along the scale without any material alteration in pressure. Before making the experiment the stopper *c* is opened so as to equalise the pressure. Between the binding screws *a* and *b* a fine platinum wire is stretched. When a Leyden jar is discharged through the wire it becomes heated, expands the air in the bulb, and the expansion is indicated by the motion of the liquid along the graduated stem of the thermometer. In this way it was found that the heat in the wire is proportional to the square of the quantity of electricity divided by the surface—a result which follows from the formula already given (801). Riess also found that *with the same charge, but with wires of different dimensions, the rise of temperature is inversely as the fourth power of the diameter*. Thus, compared with a given wire as unity, the *rise of temperature* in a wire of double or treble the diameter would be $\frac{1}{16}$ or $\frac{1}{27}$ as small; but as the masses of these wires are four and nine times as great, the *heat produced* would be respectively $\frac{1}{4}$ and $\frac{1}{3}$ as great as in a wire of unit thickness.

If a jar charged to a given potential is discharged through the electric thermometer, the discharge will take place at a certain striking distance, and a certain depression will be produced which is a measure of the heating effect in the thermometer. If now a card is interposed in the path of the discharge, a certain proportion of its energy will be expended in the mechanical perforation of the card, and the proportion in the thermometer will be less. Thus Riess found that that charge which, when passed through air, produced a depression of 15.9, when passed in addition through one

card, two cards, and a plate of mica, produced depressions of 11·7, 8·0, and 6·8 respectively; showing that the heating effect was less according as more of the energy of the discharge was used for other purposes.

When an electric discharge is sent through gunpowder placed on the table of a Henley's discharger, the gunpowder is not ignited, but is projected in all directions. But if a wet string is interposed in the circuit, a spark passes which ignites the powder. This arises from the retardation which electricity experiences in traversing a semi-conductor, such as a wet string; for the heating effect is proportional to the duration of the discharge.

When a charge is passed through sugar, heavy spar, fluor-spar, and other substances, they afterwards become phosphorescent in the dark. Eggs, fruit, &c., may be made luminous in the dark in this way.

When a battery is discharged through a gold leaf pressed between two glass plates or between two silk ribbons, the gold is volatilised in a violet powder which is finely divided gold. Fig. 791 represents the marks left on a piece of glass by a narrow strip of tinfoil volatilised by the discharge of a Leyden battery.

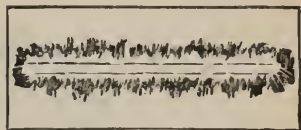

Fig. 791

Siemens showed that when a jar is charged and discharged several times in succession the glass becomes heated. Hence during the discharge there must be movements of the molecules of the glass as Faraday supposed (766); we have here, probably, something analogous to the heating produced in iron when it is rapidly magnetised and demagnetised.

807. **Magnetic effects.**—By the discharge of a large Leyden jar or battery, a steel wire may be magnetised if it is laid at right angles to a conducting wire through which the discharge is effected, either in contact with the wire or at some distance. And even a steel rod or needle may be magnetised by placing it inside a spiral of insulated copper wire, A (fig. 792), and passing one or more discharges through it. The polarity depends on the direction in which the electricity enters the coil and the way in which the wire is coiled. Thus if the jar is charged in the inside with positive electricity, and the direction in which the wire is coiled is that in which the hands of a watch move, that end at which the positive electricity enters will be a south pole.

It has, however, been frequently observed (first by Henry in 1842) that the magnetism is abnormal, and that for the same charge of the jar the polarity of the needle is not always the same. This is to be referred to the oscillatory character of the discharge (800), the position of the poles corresponding to that of the last oscillation; uniform results are obtained when a wet string is included in the circuit.

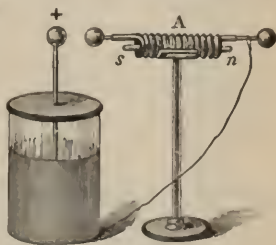

Fig. 792

808. **Mechanical effects.**—The mechanical effects are the violent lacerations, fractures, and sudden expansions which ensue when a powerful discharge is passed through a badly conducting substance. Glass is perforated, wood and stones are fractured, and gases and liquids are violently disturbed. The

mechanical effects of the electric spark may be demonstrated by a variety of experiments.

Fig. 793 represents an arrangement for perforating a piece of glass or card. It consists of two glass columns, with a horizontal cross-piece, in which is a pointed conductor, B. The piece of glass, A, where the point touches it, is surrounded by shellac, or oil, to prevent dispersion of electricity over the surface : it is supported on an insulating glass tube, in which is placed a

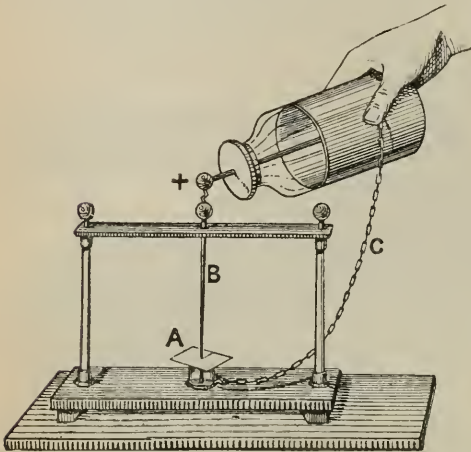

Fig. 793

second conductor, terminating also in a point, which is connected with the outside of the battery, while the knob of the inner coating is brought near the knob of B. When the discharge passes between the two conductors the glass is perforated. The experiment succeeds with a single jar only when the glass is very thin ; otherwise a battery must be used. To perforate a glass plate 1.5 cm. thick, a striking distance of 16 cm. is required.

When the discharge takes place through a piece

of cardboard between two points exactly opposite each other, the line of perforation is quite straight ; but if not exactly opposite, a slight hole is seen near the negative point. This phenomenon, which is known as *Lullin's experiment*, is probably connected with the fact that negative electricity discharges into air more readily than positive (804) ; in other words, that positive electricity must be raised to a higher potential in order to discharge, which is held to favour the view that there is a specific difference between the two kinds of electricity.

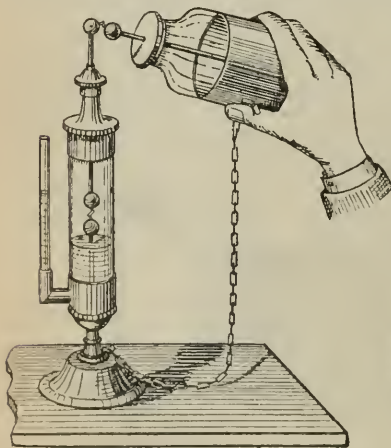

Fig. 794

The perturbation and sudden expansion which the discharge produces may be illustrated by means of what is known as *Kinnersley's thermometer*. This consists of two glass tubes (fig. 794), which fit into metallic caps and communicate with each other. At the top of the large tube is a rod terminating in a knob, and moving in a stuffing-box, and at the bottom there is

a similar rod with a knob. The apparatus contains water up to the level of the lower knob. When the electric discharge passes between the two knobs, the water is driven out of the larger tube and rises to a slight extent in the small one. The level is immediately re-established, and therefore the phenomenon cannot be due to a rise of temperature.

If the upper knob inside a Kinnorsley's thermometer is replaced by a point, and the outside knob is connected with the prime conductor of a machine at work, the electricity discharges itself in the form of a brush, and a permanent displacement of the liquid in the stem shows that this is due to the heating effect of the brush discharge.

A Leyden jar when charged undergoes a true expansion which is not that due to heat. Electric polarisation produces characteristic deformations which are known as *electrostriction*. This was most completely investigated by Quincke, one of whose experiments is represented in fig. 795. It consists of a glass bulb A about 2 inches in diameter at the end of a narrow capillary tube K, on an enlargement in which a platinum wire, B, is fused. The bulb and a portion of the stem contains a conducting liquid, such as water or sulphuric acid, and it is placed in a vessel of ice-cold water, K, which can be connected with the earth by a conducting wire, G. If now this condenser is charged by connecting the wire B with an electric machine, while G is in connection with the earth, there is a distinct depression of the liquid in the tube. When the jar is discharged the liquid resumes its original level. Hence this cannot have been due to heat, apart from the fact that the temperature was kept constant; nor is it due to a contraction of the thickness of the glass. The same results are obtained if the outer coating is insulated by resting it on shellac, T, which in turn is insulated by resting on a slab of india rubber, the inner coating being put to earth. Similar effects are observed with solid condensers of other materials, and also with liquids.

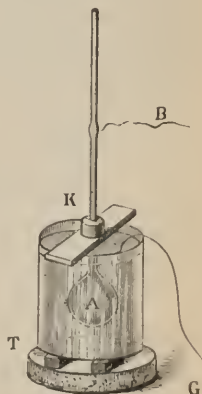

Fig. 795

809. **Chemical effects.**—When two gases which act on each other are mixed in the proportions in which they combine, a single spark is often sufficient to determine their combination; but when either of them is in great excess, a succession of sparks is necessary. Priestley found that when a series of electric sparks was passed through moist air, its volume diminished, and blue litmus introduced into the vessel was reddened. This, Cavendish discovered, was due to the formation of nitric acid.

Several compound gases are decomposed by the continued action of the electric spark. With ethylene, sulphuretted hydrogen, and ammonia, the decomposition is complete; while carbonic acid is partially decomposed into oxygen and carbonic oxide. The electric discharge also by suitable means can feebly decompose water, oxides, and salts; but, though the same in kind, the chemical effects of statical electricity are by no means so powerful and varied as those of dynamical electricity. The chemical action of the spark is easily demonstrated by means of a solution of potassium iodide.

A small lozenge-shaped piece of filtering paper, impregnated with this solution, is placed on a glass plate, and one corner connected with the ground. When a few sparks from a conductor charged with positive

electricity are taken at the other corner, brown spots are produced, due to the separation of iodine.

The *electric pistol* is a small apparatus which serves to demonstrate the chemical

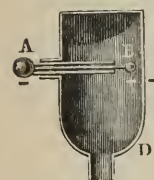

Fig. 796

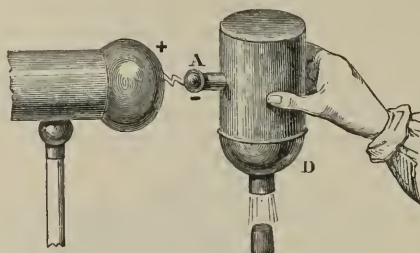

Fig. 797

effects of the spark. It consists of a brass vessel (fig. 796), in which is introduced a detonating mixture of two volumes of hydrogen and one of oxygen, and which is then closed with a cork. In a tubulure in the side there is a glass tube, in which fits a metal rod, terminated by the knobs

A and B. The vessel is held as represented in fig. 797, and brought near the machine. The knob A becomes negatively, and B positively, electrified by induction from the machine, and a spark passes between the conductor and A. Another spark passes at the same time between the knob B and the side: this determines the combination of the gases, which is accompanied by a great disengagement of heat, and the vapour of water formed acquires such an expansive force that the cork is projected with a report like that of a pistol.

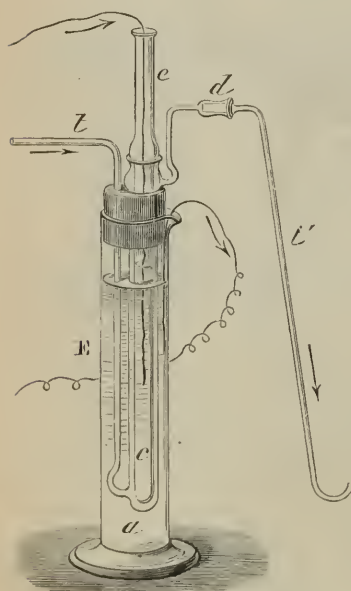

Fig. 798

electric in a charged condenser. An apparatus by which this is effected is represented in fig. 798; it is a modification of one invented by Siemens. It consists of a glass cylinder, E, containing dilute sulphuric acid; a is a glass tube closed at the bottom, and also containing sulphuric acid, in

Among the chemical effects must be enumerated the formation of *ozone*, which is recognised by its peculiar odour, and by certain chemical properties. The odour is perceived whenever an electric machine is at work, or when electricity issues from a conductor into the air through a series of points. It has been established that ozone is an allotropic modification of oxygen.

With these effects may be associated a certain class of phenomena observed when a gas is made to act as the dielectric

in a charged condenser. An apparatus by which this is effected is represented in fig. 798; it is a modification of one invented by Siemens. It consists of a glass cylinder, E, containing dilute sulphuric acid; a is a glass tube closed at the bottom, and also containing sulphuric acid, in

an enlargement of which at the top the inner tube *ec* fits. There is a tube, *t*, by which gas enters, and one, *dt'*, by which it emerges. When the acids in *E* and *e* are respectively connected with the two electrodes of a Holtz machine, or with the two terminals of a Ruhmkorff's coil, a certain condition or strain (766) is produced in the dielectric, which is known as the *silent discharge* or the *electric effluvium*. What that condition is cannot be definitely stated; but it gives rise to powerful and characteristic chemical actions, often differing from those produced by the spark.

By this apparatus large quantities of ozone may be produced.

810. **Duration of the electric spark.**—Wheatstone measured the duration of the electric spark by means of the rotating mirror which he invented for this purpose. At some distance from this instrument, which can be made to rotate with a measured velocity, a Leyden jar is so arranged that the spark of its discharge is reflected from the mirror. Now, from the laws of reflection (530) the image of the luminous point describes an arc of double the number of degrees which the mirror describes, in the time in which the mirror passes from the position in which the image begins to be visible to that in which it ceases to be so. If the duration of the image were absolutely instantaneous, the arc would be reduced to a mere point. Knowing the number of turns which the mirror makes in a second, and measuring, by means of a divided circle, the number of degrees occupied by the image, the duration of the spark would be determined. In one experiment Wheatstone found that this arc was 24°. Now, in the time in which the mirror traverses 360° the image traverses 720°; but in the experiment the mirror made 800 turns in a second, and therefore the image traversed 576,000° in this time; and as the arc was 24°, the image must have lasted the time expressed by $\frac{24}{576000}$, or $\frac{1}{24000}$ of a second. Thus the discharge is not instantaneous, but has a certain duration, which, however, is excessively short.

To determine the duration of the electric spark, Lucas and Cazin used a method by which it may be measured in millionths of a second. The method is an application of the vernier (10). A disc of mica 15 cm. in diameter is blackened on one face, and at the edge are traced 180 equal divisions in very fine transparent lines. The disc is mounted on a horizontal axis, and by means of a gas engine it may be made to turn with a velocity of 100 to 300 turns in a second. A second disc of silvered glass of the same radius is mounted on the same axis as the other and very close to it; at its upper edge six equidistant transparent lines are traced, forming a vernier with the lines on the mica. For this, the distance between two consecutive lines on the two discs is such that five divisions of the mica disc *DC* correspond to six divisions of the glass disc *AB*, as seen in fig. 799. Thus the vernier gives the sixth of a division of the mica disc (10). In the apparatus the lines *AB* are not above the lines *CD*, but are at the same distance from the axis, so that the latter coincide successively with the former.



Fig. 799

The mica disc is contained in a brass box, *D* (fig. 800), on the hinder face of which is fixed the vernier. In the front face is a glass window, *O*, through

which the coincidence of the two sets of lines can be observed by means of a magnifying lens, L.

The source of electricity is a battery of two to eight jars, each having a coated surface of 1243 square centimetres, and charged continuously by a Holtz machine. The spark strikes between two metals balls *a* and *b*, 11 mm. in diameter. Their distance can be varied, and at the same time measured, by means of a micrometric screw, *r*. The discharge spark occurs between *a* and *b* at the principal focus of a condensing lens placed in the collimator, so that the rays which fall on the vernier are parallel.

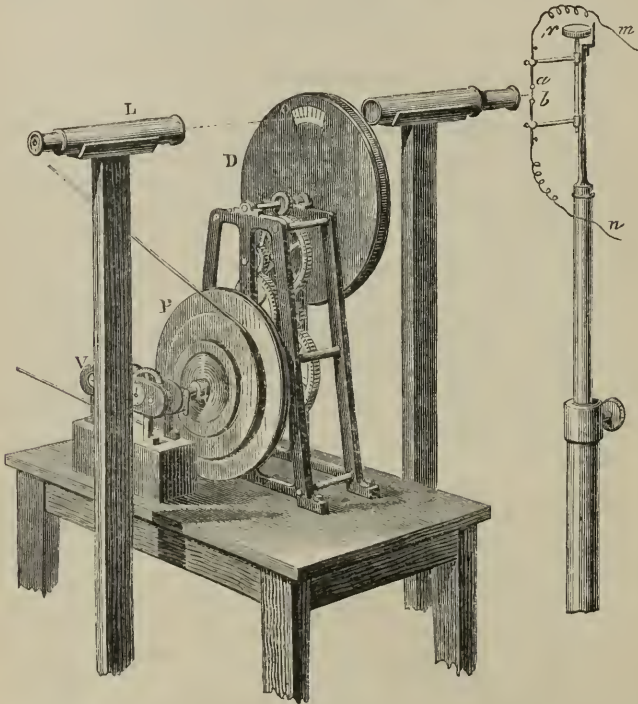

Fig. 800

The motion is transmitted to the toothed wheels and to the mica disc by means of an endless band, which can be placed on any one of three pulleys *P*, so that the velocity may be varied. At the end of the axis of the pulleys is a bent wire which moves a counter *V*, that marks on three dials the number of turns of the disc.

These details being premised, suppose the velocity of the disc is 400 turns in a second. In each second 400×180 , or 72,000 lines, pass before the observer's eye; hence an interval of $\frac{1}{72000}$ of a second elapses between two consecutive lines. But as the spark is seen only when one of the lines of

the disc coincides with one of the six lines of the vernier, and as this gives sixths of a division of the movable disc, when the latter has turned through a sixth of a division, a second coincidence is produced ; so that the interval between two successive coincidences is $\frac{1}{72000 \times 6} = 0.0000023$ of a second.

That being the case, let the duration of a spark be something between 23 and 46 ten-millionths of a second ; if it strikes exactly at the moment of a coincidence, it will last until the next coincidence ; and owing to the persistence of impressions on the retina (639) the observer will see two luminous lines. But if the spark strikes between two coincidences and has ceased when the third is produced, only one brilliant line is seen. Thus, if with the above velocity sometimes one and sometimes two bright lines are seen, the duration of the spark is comprised between 23 and 46 ten-millionths of a second.

By experiments of this kind, with a striking distance of 5 mm. between the balls *a* and *b*, and varying the number of the jars, Lucas and Cazin obtained the following results :—

Number of jars	Duration in millionths of a second
2	26
4	41
6	45
8	47

It will thus be seen that the duration of the spark increases with the number of jars, that is, with the quantity of electricity concerned in the spark. It also increases with the striking distance ; but it is independent of the diameter of the balls between which the spark strikes. The spark of electric machines has so short a duration that it could not be measured with the chronoscope.

811. **Velocity of electricity.**—To determine the velocity of electricity, Wheatstone constructed an apparatus the principle of which will be understood from fig. 801. Six insulated metal knobs were arranged in a horizontal line on a piece of wood called a *spark board* ; of these the knob 1 was connected with the outer, while 6 could be connected with the inner coating of a charged Leyden jar ; the knob 1 was the tenth of an inch distant from the knob 2 ; while between 2 and 3 a quarter of a mile of insulated wire was interposed ; 3 was likewise a tenth of an inch from 4, and there was a quarter of a mile of wire between 4 and 5 ; lastly, 5 was a tenth of an inch from 6, from which a wire led directly to the inner coating of the Leyden jar. Hence, when the jar was discharged by connecting the wire from 6 with the inner coating of the jar, sparks would pass between 1 and 2, between 3 and 4, and between 5 and 6. Thus the discharge, supposing it to proceed from the inner coating, has to pass in its course through a quarter of a mile of wire between the first and second spark, and through the same distance between the second and third.

The spark board was arranged at a distance of 10 feet from the rotating mirror, and at the same height, both being horizontal ; and the observer

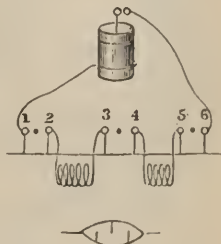

Fig. 801

looked down on the mirror. Thus the sparks were visible when the mirror made an angle of 45° with the horizon.

Now, if the mirror were at rest, or had only a small velocity, the images of the three spots would be seen as three dots ; but when the mirror had a certain velocity these dots appeared as lines, which were longer as the rotation was more rapid. The greatest length observed was 24° , which, with 800 revolutions in a second, can be shown to correspond to a duration of $\frac{1}{24 \times 800}$ of a second. With a slow rotation the lines present the appearance \equiv ; they are quite parallel, and the ends in the same line. But with greater velocity they presented the appearance \equiv , or \equiv , according to the direction of rotation of the mirror, because the image of the centre spark was formed after the lateral ones. Wheatstone found that this displacement amounted to half a degree before or behind the others; accordingly this arc corresponds to a duration of about the $\frac{1}{1125 \times 800}$ of a second; the space traversed in this time being a quarter of a mile, gives for the velocity with which the electric discharge passed along the wire under the conditions of the experiment 288,000 miles in a second, which is greater than that of light.

The time required for a message to travel along a telegraph wire has been determined under various conditions of length of line, electrostatic capacity, &c. In the following table the names of observers are given in the first column, the length of line in the second, and the velocity of electricity in the wire, obtained by dividing the length of the observed time, in the third.

	Kilometres	cm./sec.
Fizeau and Gounelle	314	1.018×10^{10}
Walker	885	$.301 \times 10^{10}$
Guillemin	1004	$.359 \times 10^{10}$
Löwy and Stephan	863	$.359 \times 10^{10}$
Hagenbach	285	1.62×10^{10}
Wheatstone	0.64	4.63×10^{10}
Velocity of Light		3.00×10^{10}

The values of the velocity of propagation of an electric signal through a wire given in the above table differ widely. Indeed, there is no definite meaning to be attached to the expression ‘velocity of electric transmission,’ since it depends upon so many conditions, such as electromotive force used, length of line, capacity and resistance of line per unit of length. We have seen that Faraday considerably diminished the rapidity of a Leyden jar discharge by including some badly conducting wet string in the circuit (806).

For Atmospheric Electricity reference must be made to the section on Meteorology.

BOOK X

DYNAMICAL ELECTRICITY

CHAPTER I

VOLTAIC CELL. ITS MODIFICATIONS

812. **Galvani's experiment and theory.**—The fundamental experiment which led to the discovery of dynamical electricity is due to Galvani, Professor of Anatomy in Bologna. Occupied by investigations on the influence of electricity on the nervous excitability of animals, and especially of the frog, he observed that when the lumbar nerves of a dead frog were connected with the crural muscles by a metallic circuit, the muscles were briskly contracted.

To repeat this celebrated experiment, the legs of a recently killed frog are prepared, and the lumbar nerves on each side of the vertebral column are exposed, having the appearance of white threads. A metal conductor, composed of zinc

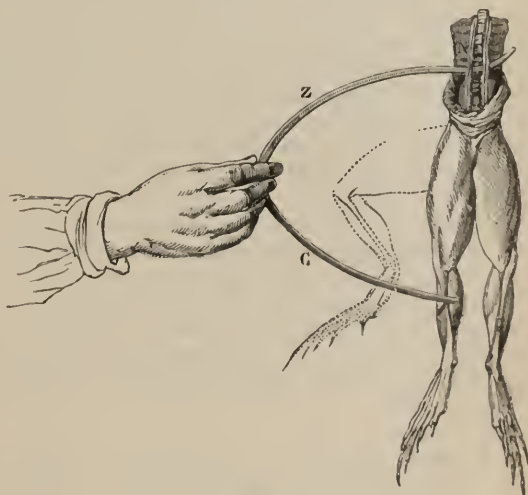

Fig. 802

and copper, is then taken (fig. 802), and one end introduced between the nerves and the vertebral column, while the other touches one of the muscles of the thighs or legs; at each contact a smart contraction of the muscles ensues.

Galvani had some time before observed that the electricity of machines produced in dead frogs analogous contractions, and he attributed the phenomena first described to an electricity inherent in the animal. He assumed

that this electricity, which he called *vital fluid*, passed from the nerves to the muscles by the metallic arc, and was thus the cause of contraction. This theory met with great support, especially among physiologists, but it was not without opponents. The most formidable of these was Alexander Volta, Professor of Physics in Pavia.

813. **Volta's fundamental experiment.**—Galvani's attention had been exclusively devoted to the nerves and muscles of the frog; Volta's was directed upon the connecting metal. Resting on the observation, which Galvani had also made, that the contraction is more energetic when the connecting arc is composed of two metals than when there is only one, Volta attributed to the metals the active part in the phenomenon of contraction. He assumed that the disengagement of electricity was due to their contact, and that the animal parts officiated only as conductors, and at the same time as a very sensitive electroscope.

By means of the condensing electroscope (795), which he had then recently invented, Volta devised several modes of showing the disengagement of electricity on the contact of metals, of which the following is the easiest to perform:—

The moistened finger being placed on the upper plate of a condensing electroscope (fig. 776), the lower plate is touched with a plate of copper *c*, soldered to a plate of zinc *z*, which is held in the other hand. On breaking the connection and lifting the upper plate (fig. 777), the gold leaves diverge, and, as may be proved, with negative electricity. If the upper plate is touched with the copper, and the lower with the finger, the leaves diverge with positive electricity. Hence, when soldered together, the copper is charged with negative electricity, and the zinc with positive electricity. The electricity could not be due either to friction or pressure; for if either upper or lower plate, each of which is of copper, is touched with the zinc plate *z*, the copper plate to which it is soldered being held in the hand, no trace of electricity is observed.

A memorable controversy arose between Galvani and Volta. The latter was led to give greater extension to his contact theory, and propounded the principle that when *two heterogeneous substances are placed in contact, one of them always assumes the positive and the other the negative electric condition*. In this form Volta's theory obtained the assent of the principal philosophers of his time. Galvani, however, made a number of highly interesting experiments with animal tissues. In some of these he obtained indications of contraction, even though the substances in contact were quite homogeneous.

814. **Disengagement of electricity in chemical actions.**—The contact theory which Volta had propounded, and by which he explained the action of the pile, soon encountered objectors. Fabroni, a countryman of Volta, having observed that, in the pile, the discs of zinc become oxidised in contact with the acidulated water, thought that this oxidation was the principal cause of the disengagement of electricity. In England Wollaston soon advanced the same opinion, and Davy supported it by many ingenious experiments.

It is true that in the fundamental experiment of the contact theory (813) Volta obtained signs of electricity. But De la Rive showed that if the zinc is held in a wooden clamp, all signs of electricity disappear, and that the

same is the case if the zinc is placed in gases, such as hydrogen or nitrogen, which exert upon it no chemical action. De la Rive accordingly concluded that in Volta's original experiment the disengagement of electricity is due to the chemical actions which result from the perspiration and from the oxygen of the atmosphere.

815. **Current electricity.**—When a plate of zinc and a plate of copper are partially immersed in dilute sulphuric acid (fig. 803), no electric or chemical change is apparent beyond a slight disengagement of hydrogen from the surface of the zinc plate. But if the plates are placed in direct contact, or are connected externally by a metal wire, chemical action sets in, a large quantity of hydrogen is disengaged; but this hydrogen is disengaged not at the surface of the zinc, but at the surface of the copper plate. Here then we have to deal with something more than mere chemical action, for chemical action would be unable to explain either the increase in the quantity of hydrogen disengaged when the metals touch, or the fact that this hydrogen is now given off at the surface of the copper plate. At the same time, if the wire is examined it will be found to possess many remarkable thermal, magnetic, and other properties which will be afterwards described.

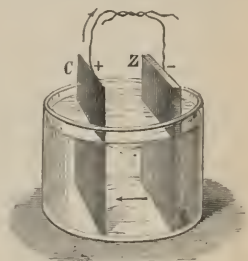

Fig. 803

In order to understand what here takes place, let us suppose that we have two insulated metal spheres, and that one is charged with positive and the other with negative electricity, and that they are momentarily connected by means of a wire. Electricity will pass from a place of higher to a place of lower potential—that is, from the positive, along the wire to the negative—and the potentials become equal. This is, indeed, nothing more than an electric discharge taking place through the wire; and during the extremely short time in which this is accomplished, it can be shown that the wire exhibits certain heating and magnetising effects, which have been considered in the Book on Frictional Electricity. If now we can imagine some agency by which the different electric conditions of the two spheres are renewed as fast as they are discharged, which is what very nearly takes place when the two spheres are respectively connected with the two conductors K and K' of a Holtz machine (figs. 744, 745), this equalisation of potentials, thus taking place, is virtually continuous, and the phenomena above mentioned are also continuous.

Now this is what takes place when the two metals are in contact in a liquid which acts upon them unequally. Before they are connected they are oppositely electrified, the copper being positive and the zinc negative. If the difference of potential between them is measured by a condensing electroscope (795) or a quadrant electrometer (796), it is found to be about one volt. Hence, when the plates are joined by a wire electricity (that is, *positive* electricity) passes from the copper to the zinc, and the difference of potential would fall but for the chemical action between the acid and the zinc, the energy of which enables the D.P. to be constantly renewed and maintained. The rapidly succeeding equalisations of potential, which take

place in the wire, being continuous so long as the chemical action continues, is what is ordinarily spoken of as the *electric current*.

If we represent by $+e$ the potential of the copper plate, and by $-e$ the potential of the zinc, then the electric difference—that is, the difference of potentials—is $+e - (-e) = 2e$. And this is general; the essential point of any such combination as the above is, that it maintains, or tends to maintain, a difference of potential, which difference is constant. If, for instance, the zinc plate is connected with the earth which is at zero potential, its potential also becomes zero; and since the electric difference remains constant, we have for the potential of the copper plate $+2e$. Similarly, if the copper is connected with the earth, the potential of the zinc plate is negative, and is $-2e$.

This difference of potential causes a flow of electricity from the copper terminal to the zinc, and thence through the liquid to the copper. Electricity flows round and round the circuit, just as water circulates in a system of hot-water pipes connected with a boiler. To provide the hot-water circulation energy is required, and is obtained from the coal which is burnt in the furnace. For the flow of electricity in the circuit energy is also required, and there is no question as to its source. The potential energy of the chemical affinity of zinc and dilute acid—which, when zinc is merely dissolved in acid, is converted into heat—is here converted into the energy of electric flow. The only question is as to the seat of the difference of potential. According to the one view it is to be found at the contacts of dissimilar substances in the circuit, at the place of contact of zinc with acid, acid with copper, but chiefly at the contact of the copper and zinc. The algebraic sum of these differences of potential constitutes the electromotive force (817) which drives the electricity round the circuit. According to the other view, the difference of potential in question is due, not to any contact force, but to the tendency to oxidation (or chemical union generally) of a metal when exposed to air or other medium. Owing to the chemical affinity of zinc and oxygen, a piece of zinc and the air which surrounds it are at different potentials, the zinc being negative and the air positive; similarly, copper and the air surrounding it are at different potentials, copper negative and air positive. But the D.P. between air and zinc is greater, owing to the greater oxidisability of the zinc, than that between air and copper. Thus, when strips of zinc and copper are brought into contact with each other, and are in consequence reduced to the same potential, there is a flow of electricity from copper to zinc, so that the zinc end of the compound strip is positively and the copper end negatively charged. Experiment shows that they are so charged.

When plates of zinc and copper are placed side by side, without touching, in dilute acid, the acid is at a higher potential than either the zinc or the copper, but the D.P. between zinc and acid is greater than that between copper and acid; thus the zinc and copper are at different potentials, the copper being positive and the zinc negative.

816. **Voltaic cell. Electromotive series.**—The arrangement just described, consisting of two different metals partly immersed side by side in a conducting liquid, constitutes a *simple voltaic element or couple or cell*. So long as the metals are not in contact, the circuit is said to be *open*, and when connected by a wire it is *closed*, the circuit being the path traversed by the electricity

from zinc to copper through the acid, and back to the zinc through the external wire. The metal which is most attacked is called the *positive* or *active* plate, and that which is least attacked the *negative* or *inactive* plate. The positive metal determines the direction of the current, which proceeds *in* the liquid from the positive to the negative plate, and *out* of the liquid through the connecting wire from the negative to the positive plate. The parts of the plates projecting above the liquid are called the poles of the cell, and usually have binding screws fastened to them for the attachment of wires. The positive pole is at the end of the copper (or other inactive) plate, the negative pole at the end of the zinc (or other relatively active) plate.

In speaking of the *direction of the current* the direction of the positive electricity is always understood.

The mere immersion of two different metals in a liquid is not alone sufficient to produce a continuous current ; there must be chemical action. When a platinum and a gold plate are connected with a delicate galvanometer, and immersed in pure nitric acid, no current is produced ; but on adding a drop of hydrochloric acid a strong current is excited, which proceeds in the liquid from the gold to the platinum, because the gold is attacked by the nitrohydrochloric acid, while the platinum is less so, if at all.

As a voltaic current is produced whenever two metals are placed in metallic contact in a liquid which acts more powerfully upon one than upon the other, there is a great choice in the mode of producing such currents. In reference to their electric department, the metals have been arranged in what is called an *electromotive series*, in which the most *electropositive* are at one end, and the most *electronegative* at the other. Hence when any two of these are placed in contact in dilute acid, the current in the connecting wire proceeds from the one lower in the list to the one higher. The principal metals range themselves as follows :—

- | | | |
|-------------|--------------|---------------|
| 1. Zinc. | 5. Iron. | 10. Silver. |
| 2. Cadmium. | 6. Nickel. | 11. Gold. |
| 3. Tin. | 7. Bismuth. | 12. Platinum. |
| 4. Lead. | 8. Antimony. | 13. Graphite. |
| | 9. Copper. | |

It will be seen that the electric department of any metal depends on the metal with which it is associated. Iron, for example, in dilute sulphuric acid is electronegative towards zinc, but is electropositive towards copper ; copper in turn is electronegative towards iron and zinc, but is electropositive towards silver, platinum, or graphite.

817. Electromotive force.—Electromotive force (written shortly E.M.F.) is that which causes electricity to move. The E.M.F. of a cell is the force causing electricity to move round the circuit consisting of cell and external wire. It is not a force in the mechanical sense, since it only acts upon electricity. It is equal to the difference of potentials of the terminals of the cell when these terminals are not connected, that is, when no current is flowing. The E.M.F. of the cell is the same whether a current is flowing or not, depending only on the metals and liquid used, but the difference of potential of the terminals falls as soon as a current is allowed to flow, to a greater

extent as the current is stronger. The electromotive force of a cell is greater in proportion to the distance of the two metals from each other in the series. That is to say, it is greater the greater the difference between the chemical action upon the two metals immersed. Thus the E.M.F. of a zinc-platinum-acid cell is greater than that of a zinc-iron-acid cell.

The unit of electromotive force is a *volt*. The E.M.F. of the zinc-copper-cell described above is about 0.9 volt.

The electromotive force of a cell is influenced by the condition of the metal for given metals; rolled zinc, for instance, is negative towards cast zinc. It also depends on the concentration of the liquid; in dilute nitric acid zinc is positive towards tin, and mercury positive towards lead; while in concentrated nitric acid the reverse is the case, mercury and zinc being respectively electronegative towards lead and tin.

The nature of the liquid also influences the direction of the current. If two plates, one of copper and one of iron, are immersed in dilute sulphuric acid, a current is set up proceeding through the liquid from the iron to the copper; but if the plates, after being washed, are placed in solution of potassium sulphide, a current is produced in the opposite direction—the copper is now the positive metal. Other examples may be drawn from the following table, which shows the electric department of the principal metals with three different liquids. It is arranged like the preceding one: each metal being electropositive towards any one lower in the list and electronegative towards any one higher.

Caustic potash	Hydrochloric acid	Potassium sulphide
Zinc.	Zinc.	Zinc.
Tin.	Cadmium.	Copper.
Cadmium.	Tin.	Cadmium.
Antimony.	Lead.	Tin.
Lead.	Iron.	Silver.
Bismuth.	Copper.	Antimony.
Iron.	Bismuth.	Lead.
Copper.	Nickel.	Bismuth.
Nickel.	Silver.	Nickel.
Silver.	Antimony.	Iron.

A voltaic current may also be produced by means of two liquids and one metal. This may be shown by the following experiment:—In a beaker containing strong nitric acid is placed a small porous pot (fig. 804), containing strong solution of caustic potash. If two platinum wires connected with the two electrodes of an electrometer (796) are immersed respectively in the alkali and in the acid, a considerable difference of potential is indicated, the wire from the nitric acid being positive and the other negative. This arrangement constitutes a cell in which the nitric acid wire corresponds to the copper, and the alkali wire to the zinc of the ordinary cell.

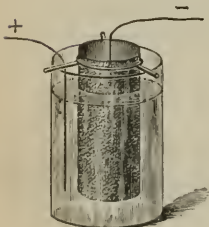

Fig. 804

It will be observed that in this cell there is no contact of different

metals. Another arrangement of metals and liquids, in which there is no contact of dissimilar metals, was devised by Dr. Fleming. It consists of two test-tubes, A and B (fig. 805), containing respectively dilute nitric acid, and ammonium (or other alkaline) sulphide. A narrow strip of lead (Pb) connects the tubes, and side by side with the lead in each is a copper wire. In the cell A lead is the more active metal, and the current flows through the acid from lead to copper; but in the cell B the sulphide acts more powerfully on the copper than on the lead, and the current flows from copper to lead. Thus when the copper terminals are connected by a copper wire, the current has the same direction in the two cells, and we have an effective battery but no contacts of dissimilar metals.

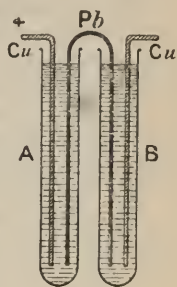

Fig. 805

A metal which is acted upon by a liquid can be protected from solution by placing in contact with it a more electropositive metal, and thus forming a simple voltaic circuit. This principle is the basis of Davy's proposal to protect the copper sheathings of ships, which are rapidly acted upon by sea-water. If zinc or iron is connected with the copper, the metal so used is dissolved and the copper protected. Davy found that a piece of zinc the size of a nail was sufficient to protect a surface of forty or fifty square inches; unfortunately the proposal has not been of practical value, for the copper must be attacked to a certain extent to prevent the adherence of marine plants and shellfish.

818. **Voltaic pile. Voltaic battery.**—When a series of voltaic cells is arranged so that the zinc of one cell is connected with the copper of another, the zinc of this with the copper of another, and so on, the arrangement is called a *voltaic battery*; and by its means the effects produced by a single cell are capable of being very greatly increased.

The earliest of these arrangements was devised by Volta himself. It consists (fig. 806) of a series of discs piled one over the other in the following order:—At the bottom, on a frame of wood, is a disc of copper, then a disc of cloth moistened by acidulated water or by brine, then a disc of zinc; on this a disc of copper, and another disc of moistened cloth, to which again follow as many sets of copper-cloth-zinc, always in the same order, as may be convenient, the highest disc being of zinc. The discs are kept in a vertical position by glass rods.

It will be readily seen that we have here a series of simple voltaic couples, the moisture in the cloth acting as the liquid in the cases already mentioned, and that the terminal zinc is the negative and

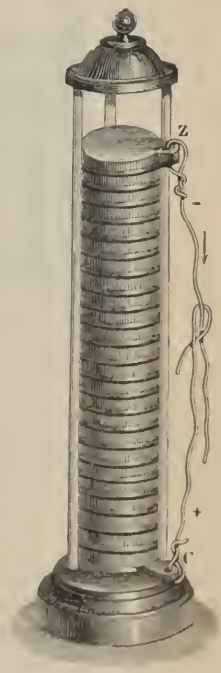

Fig. 806

the terminal copper the positive pole. From the mode of its arrangement, and from its discoverer, the apparatus is known as the *voltaic pile*, a term applied to all apparatus of this kind for accumulating the effects of dynamical electricity.

The original form of the voltaic pile has a great many inconveniences, and possesses now only an historical interest. It has received a great many improvements, the principal object of which has been to facilitate manipulation, and to produce greater electromotive force.

One of the earliest of these modifications was the crown of cups, or *couronne des tasses*, invented by Volta himself. An improved form of this is known as *Wollaston's battery* (fig. 807); it is arranged so that when the current is not wanted the action of the battery can be stopped.

The plates Z are of thick rolled zinc, and usually about eight inches in length by six in breadth. The copper plates, C, are of thin sheet, and bent

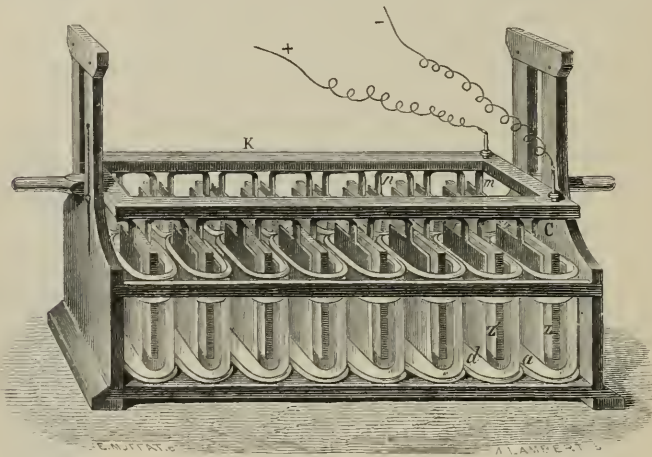

Fig. 807

so as to surround the zincs without touching them, contact being prevented by small pieces of cork. To each copper plate a narrow strip of copper, *a*, is soldered, which is bent twice at right angles and is soldered to the next zinc plate; and the first zinc, Z, is surrounded by the first copper C; these two constitute a couple, and each couple is immersed in a glass vessel, containing acidulated water. The copper C is soldered to the second zinc by the strip *a*, and this zinc is in turn surrounded by a second copper, and so on.

Fig. 807 represents a pile of sixteen couples united in two parallel series of eight each. All these couples are fixed to a cross frame of wood, by which they can be raised or lowered at pleasure. When the battery is not wanted, the couples are lifted out of the liquid. The water in these vessels is usually acidulated with $\frac{1}{10}$ sulphuric and $\frac{2}{10}$ nitric acid.

819. **Amalgamated zinc. Local action.**—Perfectly pure distilled zinc is not attacked by dilute sulphuric acid, but becomes so when immersed in that

liquid in contact with a plate of copper or of platinum. Ordinary commercial zinc, on the contrary, is rapidly dissolved by dilute acid.

This is due to what is called *local action*, and arises from impurities which are always present in commercial zinc. To understand this effect, consider two portions, *a* and *b*, of a plate of zinc placed in dilute acid (fig. 808), *a* representing pure zinc, while *b* is supposed to represent such an impurity as a particle of lead or iron. Here are all the conditions for the production of an electric current, two different metals in metallic connection, and in contact with a liquid, which acts upon them unequally; the effect is that a current is produced from *a* to *b* through the liquid, and the zinc is eaten away.

All ordinary zinc contains metallic impurities, such as lead and iron, which realise the above conditions, forming innumerable *local electric currents*, which rapidly wear away the active plate without contributing anything to the general current.



Fig. 808

Zinc, when *amalgamated*, acquires the properties of perfectly pure zinc, and is unaltered by dilute acid, so long as it is not in contact with a copper or some other metal plate immersed in the same liquid. To amalgamate a zinc plate, first immerse the plate in dilute sulphuric or hydrochloric acid so as to obtain a clean surface, and then place a drop of mercury on the plate and spread it over with a brush. The amalgamation takes place immediately, and the plate has the brilliant aspect of mercury. Zinc and other metals are readily amalgamated by dipping them in an amalgam of 1 part sodium and 200 parts of mercury. Zinc may also be amalgamated in the mass by melting it in a closed vessel with 4 per cent. of mercury and running it into moulds.

The amalgamation of the zinc removes from its surface all the impurities, especially the iron. The mercury effects a solution of pure zinc, which covers the surface of the plate as with a liquid layer. The process was first applied to electric batteries by Kemp. Amalgamated zinc is not attacked so long as the circuit is not closed—that is, when there is no current; when closed the current is more regular, and at the same time stronger, for the same quantity of metal dissolved.

820. Enfeeblement of the E.M.F. of a cell. Polarisation.—The batteries already described—which consist essentially of two metals and one liquid—labour under the objection that the currents produced rapidly diminish in strength.

This is due principally to three causes: the first is the decrease in the chemical action owing to the neutralisation of the sulphuric acid by its combination with the zinc. This is a necessary action, for upon it depends the current; it therefore occurs in all batteries, and is without remedy except by replacement of acid and zinc. The second is due to local action (819). The third arises from the production of an inverse electromotive force, which acting against the electromotive force of the battery or cell tends to neutralise it. In the fundamental experiment (fig. 803), when the circuit is closed zinc sulphate is formed, which dissolves in the liquid, and at the same time a layer of hydrogen gas is gradually formed on the surface of the copper

plate. This diminishes the activity of the combination in more than one way. In the first place, it interferes with the contact between the metal and the liquid; in the second place, the hydrogen, being highly oxidisable, gives rise to a difference of potential opposed to that which is causing the flow of electricity round the circuit. Thus, the active E.M.F. is less than the original E.M.F. due to the zinc and copper by that which results from the presence of the hydrogen on the copper plate, or is equal to $E - e$, where E is the original E.M.F. and e the *E.M.F. of polarisation*. In consequence of polarisation the E.M.F. of a zinc-copper-acid cell is reduced from '9 volt to '5 volt or less.

The polarisation of the plate is not a mere surface effect, for if the polarised copper plate is removed, washed and replaced, it will be found that the original E.M.F. of the cell, though partially, is not entirely, restored. It may be recovered, however, by passing the current of another battery through the cell in the opposite direction to its own current.

The change in the electric condition of a copper plate caused by a film of hydrogen may be illustrated by the following experiment:—Cut two strips of copper from the same sheet, and place them side by side in dilute sulphuric acid. They have the same potential, and therefore produce no deflection when joined to the terminals of a galvanometer (839). Now remove one of the strips, let it touch for a few seconds a piece of zinc in a separate vessel of acid, wash, and restore it to its place. At once the galvanometer indicates the passage of a current through it. The two strips play the part of the zinc and copper of an ordinary cell, the current leaving by the untouched strip and returning by that which has been hydrogenised.

CONSTANT CELLS

821. **Constant cells.**—With few exceptions, batteries composed of cells with a single liquid have gone out of use, in consequence of the rapid enfeeblement of the current due to polarisation. A constant cell is one whose E.M.F. remains constant for a considerable time when driving a current round a circuit, and which therefore provides a constant current.

The essential point to be attended to in securing a constant current is to prevent the polarisation of the inactive metal; in other words, to hinder any permanent deposition of hydrogen on its surface. This is effected by placing the inactive metal in a liquid upon which the deposited hydrogen can act chemically.

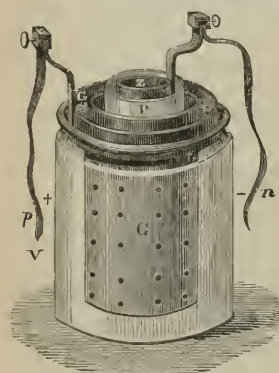
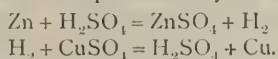

Fig. 809

822. **Daniell's battery.**—This was the first form of constant battery, and was invented by Daniell in the year 1836. As regards the constancy of its action, it is perhaps still the best of all constant batteries. Fig. 809 represents a single cell. A glass or porcelain vessel, V , contains a saturated solution of copper sulphate, in which is immersed a copper perforated cylinder, G , open at both ends. At the upper part of this cylinder there is an annular shelf, G , perforated and below the level of the solution; this is intended to support crystals of

copper sulphate to replace that decomposed as the electric action proceeds. Inside the cylinder is a thin porous vessel, P, of unglazed earthenware, which contains dilute sulphuric acid, and in it is placed the cylinder of amalgamated zinc, Z. Two thin strips of copper *p* and *n*, fixed by binding screws to the copper and to the zinc, serve for connecting the cells in series.

When the circuit of a Daniell's cell is closed, the hydrogen resulting from the action of the dilute acid on the zinc, instead of being liberated on the surface of the copper plate, meets with the copper sulphate, and reduces it with the formation of sulphuric acid and metallic copper, which is deposited on the surface of the copper plate. In this way copper is gradually removed from the solution; and if it were all consumed, hydrogen would be deposited on the copper, and the current would lose its constancy. This loss is prevented by the crystals of copper sulphate which keep the solution saturated. The action which takes place is represented by the equations



The E.M.F. of a Daniell's cell is about 1.08 volt, and remains constant, when the cell is in action and on short circuit, for several hours.

823. **Minotto's cell. Gravity cell.**—These cells are modifications of that of Daniell, and are remarkable for their economy and the facility with which they are constructed. The object is to get rid of the porous pot, the use of which is attended with numerous drawbacks.

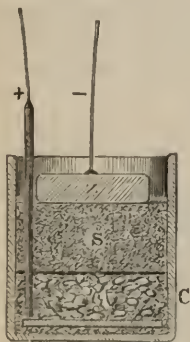

Fig. 810

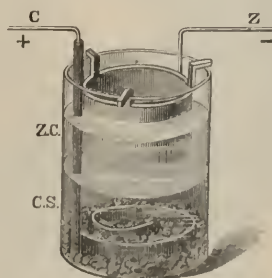

Fig. 811

The Minotto cell (fig. 810) consists of a glass or earthenware vessel, at the bottom of which is a copper disc, to which is riveted an insulated copper wire. This is surrounded by a thick layer of crystals of sulphate of copper, and on the latter a flannel disc is placed. Next comes a thick layer of sawdust, and on this rests a round zinc block, to which a wire is attached. The sawdust is soaked in water, to which a few drops of acid have been added and the excess of water squeezed out. There is thus a solution of copper sulphate at the bottom, and one of acidulated water at the top. When the circuit is closed by connecting the poles of the cell, an action is set up which is identical with that of the ordinary Daniell. For arrangement in series the zinc block is cast on to the wire from the copper plate.

This battery is largely employed for testing the fuses used in firing guns, exploding mines, &c., as its E.M.F. is constant and its resistance may be made very large by squeezing the moisture out of the sawdust.

Another form is known as the *gravity battery*, in which the porous diaphragm is altogether dispensed with. A cell of this battery is depicted in fig. 811. The copper plate, in this case a spiral copper band, provided with an insulated wire, C, is immersed in a saturated solution of copper sulphate, while on the top of this a solution of zinc sulphate floats in consequence of its lower specific gravity. The zinc block rests, by means of lugs, on the top of the vessel. When the terminal wires are connected, action is at once set up.

Such elements as these cannot be moved about, for otherwise the liquids would mix, metallic copper would be deposited on the zinc plate and give rise to local action. But they are well adapted for working heavy telegraph lines in permanent stations.

824. **Grove's battery.**—In this battery the copper sulphate solution is replaced by nitric acid, and the copper by platinum, by which greater electromotive force is obtained. Fig. 812 represents one of the forms of a cell of this battery. It consists of a flat rectangular glass or porcelain vessel, partially filled with dilute sulphuric acid (1 : 8); of a zinc plate bent into a U shape, a flat porous pot containing strong nitric acid and a thin platinum foil, which can be connected with the zinc of the next cell by a suitable binding screw. In this battery the hydrogen, which would be disengaged on the platinum, meeting the nitric acid, decomposes it, forming nitrogen tetroxide, which dissolves, or is disengaged as nitrous fumes. Grove's battery is one of the most powerful of the two-fluid batteries. It is, however, expensive, owing to the high price of platinum; besides which the platinum is liable, after some time, to become brittle and break very easily. But as the platinum is not consumed, it retains most of its value, and when

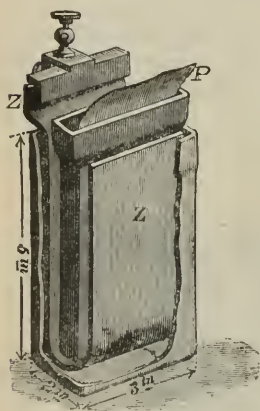
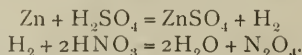

Fig. 812

the plates which have been used in a battery are heated to redness they regain their elasticity. The E.M.F. of a Grove's cell is about 1.85 volts, and its internal resistance rather less than that of a Daniell's cell of the same size. The chemical changes which take place in it are represented by the equations



825. **Bunsen's battery.**—*Bunsen's* battery was invented in 1843; it is in effect a Grove's battery, where the plate of platinum is replaced by a cylinder of carbon. This is made either of the graphitoidal carbon deposited in gas retorts, or by calcining in an iron mould an intimate mixture of coke and bituminous coal, finely powdered and strongly compressed. Both those modifications of carbon are good conductors. Each element consists of the

following parts:—1, a vessel, F (fig. 813), either of stoneware or of glass, containing dilute sulphuric acid; 2, a hollow cylinder, Z, of amalgamated zinc; 3, a porous vessel, V, in which is strong nitric acid; 4, a rod of carbon, C, prepared in the above manner. In the vessel F the zinc is first placed, and in it the carbon C in the porous vessel V as seen in P.

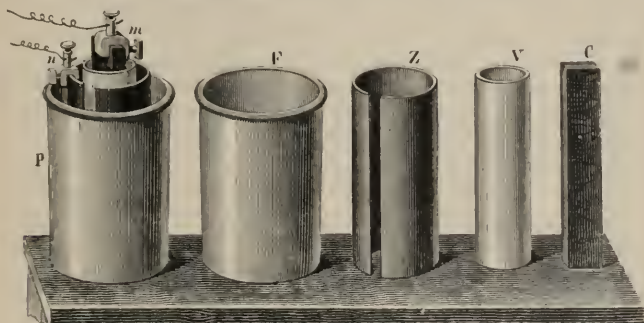

Fig. 813

A single cell of the ordinary dimensions, 20 cm. in height and 9 cm. in diameter, has a resistance of about 0.14 ohm, and an E.M.F. of about 1.82 volt (848).

When the cells are arranged to form a battery (fig. 814) each carbon is connected to the zinc of the following cell by means of the clamps *mm*, and a strip of copper, *c*, represented in the top of the figure. The copper is pressed

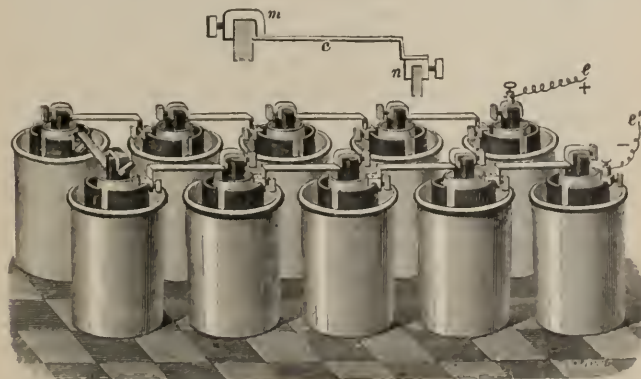

Fig. 814

at one end between the carbon and the clamp, and at the other it is soldered to the clamp *n*, which is fitted on the zinc of the following cell, and so forth. The clamp of the first carbon and that of the last zinc are alone provided with binding screws, to which are attached the wires.

The chemical action of Bunsen's battery is the same as that of Grove's. Being as powerful as and less costly than Grove's, it is very generally used on

the Continent ; but though its first cost is less, it is more expensive to work and is not so convenient to manipulate.

Callan's battery is a modified form of Grove's. Instead of zinc and platinum, zinc and platinised lead are used ; and instead of nitric acid Callan used a mixture of sulphuric acid, nitric acid, and saturated solution of nitre. The battery is said to be equal in its action to Grove's, and is much cheaper.

Callan also constructed a battery in which zinc in dilute sulphuric acid forms the positive plate, and cast iron in strong nitric acid the negative. Under these circumstances the iron becomes passive ; it is strongly electro-negative and does not dissolve. If, however, the nitric acid becomes too weak, the iron dissolves with disengagement of nitrous fumes.

After being in use some time, all the batteries in which the polarisation is prevented by nitric acid disengage nitrous fumes in large quantities, and this is a serious objection to their use, especially in closed rooms. To prevent this, nitric acid is frequently replaced by chromic acid, or by a mixture of 4 parts potassium bichromate, 4 parts sulphuric acid, and 18 water. The liberated hydrogen reduces the chromic acid to the state of chromic oxide, which combines with the sulphuric acid forming chromous sulphate. With the same view, sesquichloride of iron is sometimes substituted for nitric acid ; it becomes reduced to protochloride. But the action of the elements thus modified is considerably less than when nitric acid is used, owing to the greater resistance.

826. Smee's and other batteries.—In Smee's battery the polarisation of the negative plate is diminished by mechanical means. Each cell consists of a sheet of platinum placed between two vertical plates of zinc, but as there is only a single liquid, dilute sulphuric acid, the elements have much the form of those in Wollaston's battery. The adherence of hydrogen to the negative plate is prevented by covering the platinum with a deposit of finely divided platinum. In this manner the surface is roughened, and the disengagement of hydrogen is facilitated to a remarkable extent, and consequently the resistance of the cell diminished. For platinum, silver covered with a deposit of finely divided platinum is frequently substituted, as being cheaper.

De la Rue and Müller's cell consists of a glass tube about 6 inches long by 0·75 inch in diameter, closed by a vulcanised india-rubber stopper, through which passes a zinc rod 0·18 inch in diameter and 5 inches long. A flattened silver wire also passes through the stopper to the bottom of the tube, in which is placed about half an ounce of silver chloride, the greater part of the cell being filled with solution of sal-ammoniac. The hydrogen evolved at the negative plate reduces the chloride to metallic silver, which is thereby recovered. Since there is only one liquid, and the solid electrolyte is not acted upon when the circuit is open, the cell is easily worked and requires little attention. It is very compact, a battery of 1000 cells occupying a space of less than a cubic yard ; De la Rue and Müller have used as many as 14,400 such cells in investigations on the stratification of the electric discharge in a vacuum tube. A battery of 8040 of these cells gave a spark $\frac{1}{3}$ of an inch in length in air under the ordinary atmospheric pressure ; while under a pressure of a quarter of an atmosphere the striking distance was $1\frac{1}{7}$ inch (805).

The electromotive force of a silver chloride cell is 1·03 volt, and that of

one made with silver bromide is 0.908 ; hence a series of three of the silver chloride cells with one of bromide gives an average electromotive force of 1 volt (831).

A convenient form of cell for many purposes is the *potassium bichromate*, or, as it is frequently termed, the *bichromate cell* (fig. 815). It consists of a zinc plate, Z, attached to a brass rod, which slides up and down in a brass tube in an ebonite or porcelain cover, so that it can be wholly or partially immersed in the liquid. This is necessary since the zinc is attacked by the exciting liquid when the cell is on open circuit. Two graphite plates, C C, are similarly fitted in the cover, and by means of strips of brass the carbon and the zinc plates are respectively in connection with the binding screws, which thus form the poles. The exciting liquid is a mixture of 1 part of potassium bichromate, 2 of sulphuric acid, and 10 of water. Instead of potassium bichromate, chromic acid, which is now prepared industrially at a cheap rate, is often used.

The electromotive force is about 2 volts; when the cell is short-circuited its E.M.F. increases slightly at first, then remains constant for some time, after which it rapidly sinks to half its original amount.

In *Niaudet's cell* a zinc cylinder dips in a solution of common salt and surrounds a porous vessel, containing a carbon plate packed in with pieces of carbon and chloride of lime, which does not act on the zinc even when the circuit is closed. The electromotive force is 1.7 volt.

The cell of *Lalande and Chaperon* consists of zinc in a 30 per cent. solution of caustic potash and copper in contact with copper oxide which acts as depolariser. The E.M.F. is 0.85 volt, and there is no action unless the circuit is closed. To prevent the absorption of carbonic acid by the potash, the solution is covered with paraffin oil.

In the *Edison-Lalande cell* the copper oxide is finely ground and compressed into plates. In other respects the cell is similar to the Lalande-Chaperon. Its internal resistance is small relatively to its size, and there is no local action.

827. **Latimer Clark's standard cell.**—Latimer Clark's cell is much used as a standard of electromotive force. One form of it, represented in fig. 816, consists of two vertical glass branches with platinum wires sealed in the closed ends, and joining in a neck in which is a ground-glass stopper with a thermometer. In one of these branches is mercury forming the negative plate, and in the other an amalgam of zinc and mercury forming the positive plate. On the mercury is placed a



Fig. 815



Fig. 816

paste formed by triturating together mercurous sulphate with mercury and zinc sulphate, and on both the amalgam and the paste is a layer of crystals of zinc sulphate, the vessel being filled with saturated solution of zinc sulphate. This cell is not at all adapted for anything of the nature of continuous work, but it furnishes a standard of E.M.F. which when the cell is constructed with the proper precautions can always be reproduced and always relied on. Its E.M.F., assuming the international ohm (850) to be the unit of resistance, is $1.434 [1 - 0.0078(t - 15)]$ volts, where t is the temperature Centigrade.

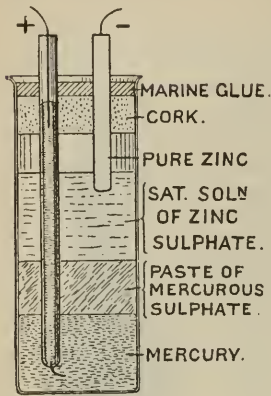
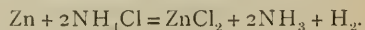

Fig. 817

Another and more common form of the Clark cell is illustrated in fig. 817. The glass cell which contains the elements is about 4 inches high and $1\frac{1}{2}$ inch in diameter.

828. **Leclanché's cell.**—This very widely used cell consists (fig. 818) of a rod of carbon, C, placed in a porous pot, which is then very tightly packed with a mixture of pyrolusite (manganese peroxide) and gas graphite, M, covered over with a layer of pitch. To the top of the carbon is firmly attached a mass of lead, L, to which is affixed a binding screw. The positive plate is a rod of zinc, Z, in which is fixed a copper wire. The zinc is generally amalgamated, although amalgamation is not so necessary as it is in those cells in which zinc is associated with sulphuric acid. The exciting liquid consists of a strong solution of sal-ammoniac, contained in a glass vessel G. The E.M.F. of the element is 1.4 to 1.5 volt; its internal resistance varies of course with the size. The chemical changes which take place in this cell when in action are as follows: The zinc and sal-ammoniac combine with each other with the formation of zinc chloride, ammonia, and hydrogen, as represented by the equation



The ammonia is dissolved in the liquid, and its presence does not interfere with the action of the cell. The hydrogen combines with the manganese peroxide,

which it deoxidises into sesquioxide, combining with the oxygen which is withdrawn, according to the equation $\text{H}_2 + 2\text{MnO}_2 = \text{H}_2\text{O} + \text{Mn}_2\text{O}_3$. If the current is feeble, and the chemical action consequently slow, the hydrogen is oxidised as fast as it produced, so that there is no accumulation

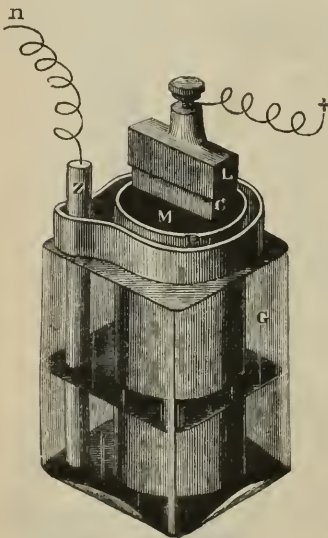

Fig. 818

of hydrogen, and consequently no polarisation. The Leclanché cell is thus a constant cell, provided that the external resistance is sufficiently large. But if the resistance is small, and the current consequently large, the chemical action is rapid, and hydrogen is produced faster than it can be got rid of, and so the cell is polarised, and its E.M.F. falls to an extent which increases with the strength of current. Thus the battery is not adapted for continuous work as in heavy telegraphic circuits, or in electro-plating, since it soon becomes polarised; it has, however, the valuable property of quickly regaining its original E.M.F. when left at rest, and is extremely well adapted for discontinuous work, such as that of electric bells.

A modification of this element by Von Beetz for therapeutic purposes consists of a test-tube in the bottom of which is fused a platinum wire; this is then covered to one-third the height with a layer of a mixture of bruised gas coke and pyrolusite. In other respects the element is constructed like that of De la Rue and Müller.

A drawback to the use of carbon is that, from its porosity, the exciting liquid rises, and forms local currents at the junction with the binding screw, which injure or destroy contact. This may be remedied to a very great extent by soaking the plates before use in hot melted paraffin, which penetrates into the pores, expelling the air. On cooling, it solidifies and prevents the capillary action mentioned above. By carefully scraping the paraffin from the outside, a surface is exposed which is as good a conductor as if the pores were filled with air. Measurements have shown that the resistance of a plate thus prepared is not altered.

In a recent modification of this cell the porous cell is dispensed with, and the carbon plate C placed between two similar flat prisms (fig. 819), made by compressing a mixture of 55 parts of graphite, 40 parts of pyrolusite, and 5 parts of shellac in steel moulds at a temperature of 100° under a pressure of 300 atmospheres.

829. **Dry batteries.**—Cells of the Leclanché type, but in which the ingredients are all practically solid, have recently come into use, and are known as dry batteries. Zinc and carbon are respectively the active and inactive plates, the carbon plate or cylinder being surrounded by a paste of mixed manganese peroxide, plumbago, and syrup, and placed inside a zinc cylinder, which serves as containing vessel. The space between the zinc and the peroxide paste is filled with a mixture of plaster of Paris, flour, and sal-ammoniac. Such cells have, when freshly made up, an E.M.F. of 1.4 or 1.5 volt, but this rapidly falls. It may be restored by passing a reverse current through the cell from an independent source.

In a dry pile the liquid is replaced by a solid hygrometric substance, such as paper. Dry piles are of various kinds; in Zamboni's, which is most extensively used, the materials are tin or silver and manganese peroxide. To construct one of these piles a piece of paper silvered or tinned on one

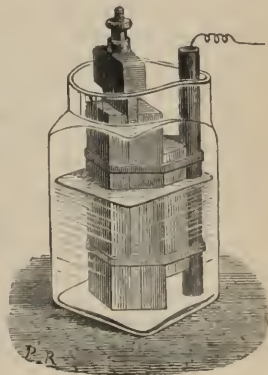

Fig. 819

called an *ohm*. The unit of current, called an *ampere*, is the current due to an electromotive force of one volt working through a resistance of one ohm.

The *coulomb* is the practical unit of electric quantity; it is that quantity of electricity which passes in a second through the section of a conductor traversed by a current of an ampere.

832. **Comparison of voltaic battery with frictional electric machine.**—The difference of potential between the prime conductor of a frictional electric machine and the earth, or between the separated electrodes of an influence machine, is enormously great as compared with that between the poles of a voltaic cell. When cells are joined together in series to form a battery the D.P. at the terminals increases with the number of cells. De la Rue and Müller constructed a chloride of silver battery (826) of 11,000 cells, which gave a spark between brass spheres .049 inch long. More recent observations have shown that about 4500 volts are necessary to produce a spark 1 mm. long between small spheres, and 33,000 volts when the spark-distance is 1 cm. Sparks many inches long are obtained from an ordinary Voss or Wimshurst machine, and although the D.P. does not increase in the same ratio as the spark distance, the electromotive forces involved are enormously high. On the other hand, the quantity of electricity produced by a Voss or other machine is small. The current which a machine, giving 5-inch sparks, would produce, would cause only a small motion of the needle of a galvanometer (839), which is violently deflected by the current derived from a pin-needle-acid cell. There is, however, no essential difference between the electricity of the electric machine and that of the voltaic cell. The E.M.F. of the latter is small, but the quantity of electricity it is capable of yielding in a given time is very large. In frictional electricity the electromotive forces are large—we are dealing with hundreds and thousands of volts when we rub a glass rod with silk—but the quantity of electricity is small. It has been seen (801) that when a charge Q passes between two points maintained at a difference of potential V , the energy of the discharge is QV , and exactly the same expression applies to the passage of a quantity Q through a wire forming part of a closed voltaic circuit, when V is the difference of potential at its ends.

CHAPTER II

MAGNETIC FIELD DUE TO A CURRENT. GALVANOMETERS

833. **Detection and measurement of voltaic currents.**—When the poles of a cell or battery are connected by a wire, there is a flow of electricity round the circuit. The current gives rise to various effects—chemical, magnetic, thermal, &c.—but since for the detection and measurement of the current the magnetic effects are generally the most suitable, we proceed to describe them first.

834. **Magnetic field due to a current.**—When a current flows in a straight wire a magnetic field is created in the surrounding space, the lines of force being circles in planes at right angles to the wire, with their centres in its axis. The existence of this field may be conveniently shown by a vertical wire forming part of a voltaic circuit which passes at right angles through a piece of cardboard. Iron filings sprinkled on the cardboard are seen to

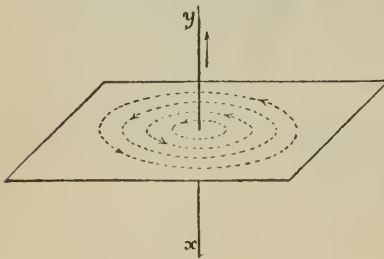

Fig. 820

arrange themselves in circles concentric with the wire as represented in fig. 820. If the direction of the current in the wire xy is that shown by the arrow, the direction of the lines of force is from right to left for an observer placed in the current. The direction of the particles of iron is that which an infinitely small magnet would have if placed there; that is, a red or north pole placed anywhere in the field

would move along a circular path towards the observer's left hand. A blue or south pole would move in the contrary direction. Thus a bit of iron filing which is magnetised in the field places its magnetic axis tangential to the circle. When the card is tapped the circular lines of filings close in towards the centre, the reason being that the opposite forces acting at the ends of each tiny magnet, being not quite in the same straight line, have a resultant which is directed towards the wire. The force which acts upon a single pole is not directed to or from the centre; that is, the force is neither attractive nor repulsive, but acts at right angles to the line joining the pole to the nearest point of the wire.

The magnetic action of the current is further illustrated by immersing part of a wire which connects the poles of a battery in iron filings. The

filings are seen to adhere to it in large quantities (fig. 821), each particle setting perpendicularly to the wire; they become detached as soon as the current ceases, and there is no action on any non-magnetic metal.



Fig. 821

The fact and direction of the magnetic field in the neighbourhood of a straight conductor may be shown also by the apparatus of fig. 822. NS is a bent magnet, pivoted at p , so as to turn about a vertical axis. In the bend is a cup of mercury, m , in conducting connection with the magnet, while t is a circular trough of mercury always in contact with the magnet by the

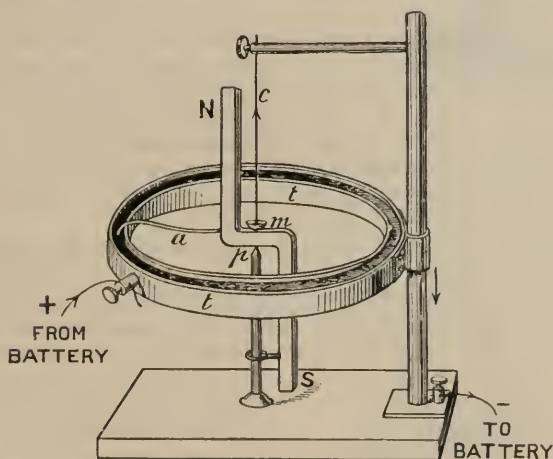

Fig. 822

arm a . The lower end of a vertical copper wire, c , dips into the mercury, m , its upper end, as well as the mercury in t , being connected with a battery. When the circuit is completed, the magnet pole, N , rotates round the wire in the anticlockwise direction if the current flows up the wire as represented in the figure. If the current is reversed, the direction of rotation will be reversed.

The magnetic force in the neighbourhood of the wire varies inversely as the distance from the wire, provided the latter is very long. If unit pole (720) is at a distance r , the force acting on it is $\frac{2C}{r}$, where C is expressed in C.G.S. units, or $\frac{2C}{10r}$ if C is expressed in amperes.

835. **Oersted's experiment.**—Oersted published in 1838 a discovery which connected magnetism and electricity in a most intimate manner, and became, in the hands of Ampère and of Faraday, the source of a new branch of physics. The fact discovered by Oersted is the directive action which a

fixed current exerts at a distance on a magnetic needle ; in other words, Oersted discovered a particular case of the magnetic action of a current.

To make this experiment a copper wire is suspended horizontally in the direction of the magnetic meridian over a movable magnetic needle, as represented in fig. 823. So long as the wire is not traversed by a current, the needle

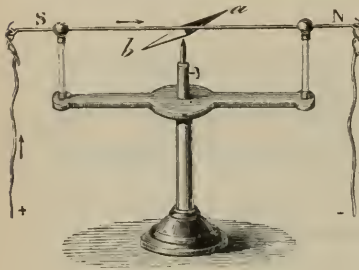

Fig. 823

remains parallel to it ; but as soon as the ends of the wire are respectively connected with the poles of a battery or of a single cell, the needle is deflected, and tends to take a position which is the more nearly at right angles to the magnetic meridian as the current is stronger.

i. If the current passes above the needle, and goes from south to north, the north pole of the magnet is deflected towards the west ; this arrangement is represented in fig. 823.

ii. If the current passes below the needle, also from south to north, the north pole is deflected towards the east.

iii. When the current passes above the needle, but from north to south, the north pole is deflected towards the east.

iv. Lastly, the deflection is towards the west when the current goes from north to south below the needle.

Ampère has given the following *memoria technica* by which all the various directions of the needle under the influence of a current may be remembered. If we imagine an observer placed in the connecting wire in such a manner

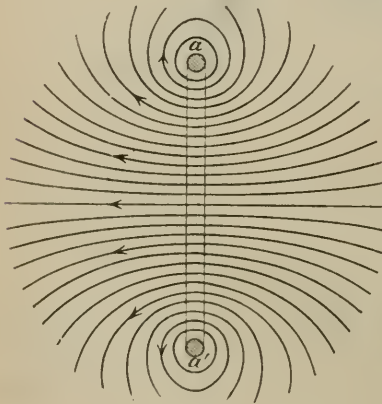

Fig. 824

that the current entering by his feet issues by his head, and that his face is always turned towards the needle, we shall see that in the above four positions the north pole is always deflected towards the left of the observer. By thus personifying the current, the different cases may be comprised in this general principle : *In the directive action of currents on magnets, the north pole is always deflected towards the left of the current.*

The lines of force in the magnetic field due to the straight horizontal current are vertical circles perpendicular to the plane of the paper. The red pole of the needle is urged along the line of force which passes through

it in one direction : the blue pole similarly in the opposite direction. But for the earth's force the needle would lie at right angles to the wire ; under the joint action of the earth's field and that due to the current, it assumes a position of equilibrium inclined to the meridian.

836. **Magnetic field due to a current in a circular wire.**—In the case in which the wire is not straight the lines of force will not be exact circles. If the conductor is a circular ring the system of lines will be as shown in fig. 824, in which a and a' are sections of the ring made by the plane of the paper. The current is supposed to come up from below at a' , and pass down through the paper at a . Near the centre of the ring the lines are straight and parallel; close to the circumference they are nearly circular. Each line of force is a closed curve threading the ring.

837. **Tangent galvanometer.**—When a small magnetic needle is supported at the centre of a vertical ring through which a current flows, the plane of the ring coinciding with the magnetic meridian, it will be subjected to the action of two magnetic fields at right angles to each other, one due to the earth, whose strength is H , and the other to the current in the ring. The latter varies from point to point, but is uniform near the centre, so that whatever direction a small needle at the centre may have, the field in which it moves is constant. Call this field F . Now it has been shown (724) that when a needle is deflected from the meridian by an angle θ , due to a transverse magnetic force F , $F = H \tan \theta$. Since F , the field at the centre of the ring, depends upon the strength of the current, $F = GC$, when C represents the strength of the current and G is a constant. Hence,

$$C = \frac{H}{G} \tan \theta, \text{ or } C \text{ varies directly as } \tan \theta.$$

An arrangement of this kind is called a *galvanometer*, since it enables us to measure the strength of a current. Galvanometers have many forms depending on various properties of a current; that now described is called a *tangent galvanometer*, since the strength of the current passing round it varies as the tangent of the deflection of the needle. The ring is generally 10 or 12 inches in diameter, and may consist of a single band of copper, as in fig. 825, when a strong current is to be measured, or of a number of turns of wire wound on a circular metal or wooden frame, when greater sensitiveness is required. Each turn of wire through which the current flows produces its own magnetic effect at the centre, and the actual field is proportional to the number of turns.

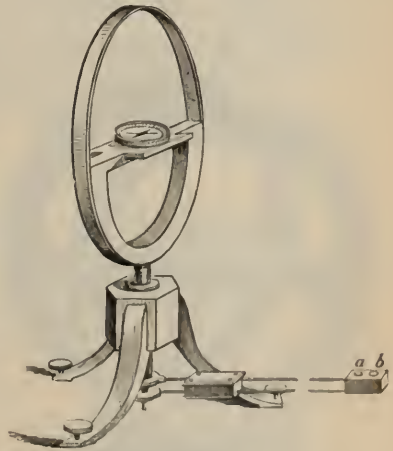

Fig. 825

The length of the needle should not exceed the twelfth part of the diameter of the circle; an aluminium or glass index attached to it moves over a graduated circle and enables its deflection from the meridian to be read off with ease and accuracy.

We may determine the value of the constant G in the formula $C = \frac{H}{G} \tan \theta$ as follows:—Since $F = GC$, G is the magnetic force at the

centre of the ring or coil due to unit current. Consider first a ring or single turn of wire, and let r (cm.) be its radius. Each element of it, subtending an angle at the centre as small as we please, produces its own effect at the centre; and therefore the effect of the whole ring, which is the sum of the effects of the several elements, is proportional to $2\pi r$, or to $2\pi nr$ if there are n turns of wire in the coil, and r is the mean radius. Also the force at the centre is inversely as the square of the radius; hence $G = \frac{2\pi nr^2}{r^2} = \frac{2\pi n}{r}$. Thus

the formula for the tangent galvanometer becomes $C = \frac{Hr}{2\pi n} \tan \theta$, C being expressed in C.G.S. units, since H and r are in C.G.S. units. If C is expressed in amperes, since 10 amperes are equal to 1 C.G.S. unit of current,

$$C = \frac{10Hr}{2\pi n} \cdot \tan \theta.$$

Another form of the instrument known as the *Helmholtz tangent galvanometer* has, instead of a single ring or coil, two coils exactly alike, fixed parallel to each other and connected so that the current passes round them in the same direction. The needle is pivoted at the middle point of the line joining the centres of the two coils. The object of using two coils instead of a single coil is to increase the uniformity of the field at the centre of the needle and render the simple tangent law more strictly applicable. Theory shows that the arrangement is most advantageous when the distance between the coils is equal to the radius of either.

The instrument (fig. 826) presents four degrees of sensitiveness. If a strong current is to be measured the two thick copper rings are used whose terminals are seen between the two coils; for weaker currents the fine wire coils are used, which are divided so that either one-third or two-thirds or the whole may be used, according to the sensitiveness required. The terminals of these subdivisions of the fine wire are seen in front.

The deflection of the needle of a tangent galvanometer should not be allowed to exceed 65° . Above this the tangent of the deflection increases very rapidly with the angle, and an error of half a degree in reading the angle gives rise to a relatively large error in the value of the current.

When the instrument has been levelled, the coils, being movable about a vertical axis, are turned until they are parallel to the needle, that is, until each is in the magnetic meridian.

If the ring of the tangent galvanometer is so constructed that it can turn about its horizontal diameter, which is in the magnetic meridian, the action of the current on the needle is inversely proportional to the cosine

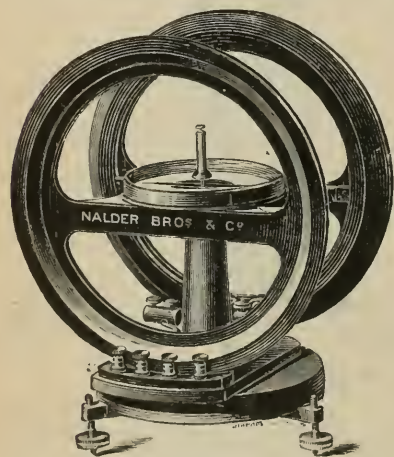

Fig. 826

of the angle θ , through which the ring is turned. Hence by increasing θ we may make the action of any current on the needle as small as we please, and thus very powerful currents may be measured by this instrument.

838. **Sine galvanometer.**—This is another form of galvanometer for measuring powerful currents. Round the circular frame M (fig. 827) several turns of stout insulated copper wire are coiled, which terminate on the binding screws at E. On a table in the centre of the ring there is a magnetic needle, m ; a second light needle, n , of glass or aluminium, fixed to the first, serves as pointer along the graduated circle N. Two copper wires, a , b , from the source of electricity to be measured, are connected with E. The circles M and N are supported on a foot O, which can move about a vertical axis passing through the centre of a fixed horizontal circle H.

The circle M being then placed in the magnetic meridian, and therefore in the same plane as the needle, the current is allowed to pass. The needle being deflected, the circle N is turned until it coincides with the vertical plane passing through the magnetic needle m . The directive action of the current is now exerted perpendicularly to the direction of the magnetic needle, and it may be shown that the strength of the current is proportional to the sine of the angle through which the coil M has been turned: this angle is measured on the circle H by means of a vernier on the piece C. The latter, fixed to the foot O, turns it by means of knob A. This angle being known, and hence its sine, the strength of the current may be thus deduced, the formula being $C = \frac{H}{G} \sin \theta$, where G is the constant of the instrument (837). Since the magnetic force at the centre of the coil M is the same whether the instrument is a tangent or is a sine galvanometer, $G = \frac{2\pi n}{r}$, r being the mean radius of the coil. The formula, then, for a sine galvanometer is

$$C \text{ (C.G.S. units)} = \frac{H}{2\pi n} \cdot \sin \theta, \text{ or } C \text{ (amperes)} = \frac{10Hr}{2\pi n} \cdot \sin \theta.$$

• Since the indication of sine galvanometer is read when the needle is in the plane of the coil, it is not necessary for the needle to be short as it is in the case

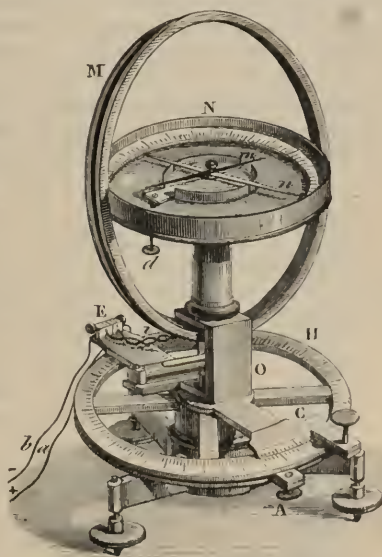

Fig. 827

of a tangent galvanometer. The number by which the sine of the deflection is multiplied to give the current in amperes is often called the *reduction factor* of the instrument. The reduction factor of a sine galvanometer is the number of amperes passing round the instrument when $\theta = 90^\circ$; for a tangent galvanometer the reduction factor is the current which would produce a deflection of 45° .

839. **Sensitive galvanometer. Astatic needles.**—The tangent galvanometer is admirably suited for comparing and measuring fairly strong currents, but is not very sensitive. The sensitiveness of a galvanometer is greater as the deflection of the needle due to a given current is greater. If for example in the case of two different galvanometers the needles are deflected respectively 1° and 2° by the passage of a given small current, the second galvanometer is twice as sensitive as the former. Now since F , the magnetic field at the centre of a vertical circular coil in the meridian, $= H \tan \theta$, $\tan \theta = \frac{F}{H}$. In order to make $\tan \theta$ (and therefore θ) as large as possible,

F must be large relatively to H ; but $F = \frac{2\pi n}{r}$ (837); therefore to make F large for a given current, n must be large and r small. Thus for sensitiveness a galvanometer must have a large number of turns of wire, and they must be as close to the needle as possible.



Fig. 828

We cannot improve the sensitiveness of a single-needle galvanometer by increasing the magnetic moment of the needle; for though the deflecting force on a strong needle, due to a current, is greater than that on a weak one, the earth's action on the needle is increased in the same proportion, and thus the deflection remains the same. What is required is a strong needle for the current field to act upon, and a weak one for the earth's field, and this condition is secured by the use of an *astatic system* of needles.

An astatic system is a combination of two parallel needles, of equal magnetic moment, rigidly joined together by copper wire, with their similar poles in opposite directions as shown in fig. 828.

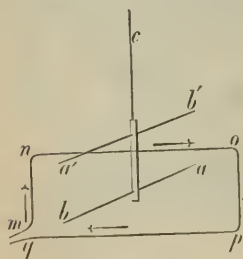

Fig. 829

If the moments of the two needles were *exactly* equal, the mechanical couple due to the earth's field on one needle would be equal and opposite to that on the other, and the combination would not stand or set in the meridian, but would lie indifferently in any azimuth. If, however, the moment of one needle is slightly greater than that of the other, the system when deflected will always return to the meridian, though the couple acting on it may be as feeble as we like.

840. **Astatic needle galvanometer.**—If wire is wound round the lower needle of an astatic pair as shown in fig. 829, in which a and a' are north poles, and a current is passed round the wire in the direction of the arrow, the lines of force in the magnetic field due to

the current pass through the coil from front to back through the paper, and return on the outside of the coil, passing through the paper from back to front. Since a north pole moves in the direction of the lines, a will move from the observer and a' towards him, and the actions of the current on the two needles concur in moving the system in the direction shown. We have thus realised the condition of having a strong combination of needles (the moment of each being as large as we can make it) for the current field to act upon, and a weak combination (since the moments of the needles are nearly but not quite equal to each other) subjected to the earth's field. Hence, since $F = H \tan \theta$, a large value of θ is obtained for a given current.

A galvanometer in which these principles are embodied is represented in fig. 830. It consists of a thick copper plate, D , resting on levelling screws; on this is a rotating plate, P , of the same metal, to which is fixed a copper frame, the breadth of which is almost equal to the length of the needles. On this is coiled a great number of turns of wire covered with silk. The two ends terminate in binding screws, i and o . Above the frame is a graduated circle, C , with a central slit parallel to the direction in which the wire is coiled. The zero corresponds to the position of this slit, and the graduations extend on each side of this zero up to 90° . By means of a very fine filament of silk an astatic system is suspended; it consists of two needles ab and $a'b'$, one above the scale, and the other within the coil itself.

When an experiment is to be made with this instrument the diameter, to which corresponds the zero of the graduation, is brought into the magnetic meridian by turning the plate P until the end of the needle ab corresponds to zero. The instrument is fixed in this position by means of the screw clamp T .

The length and diameter of the wire vary with the purpose for which the galvanometer is intended. For one which is to be used in observing the currents due to chemical actions, a wire about $\frac{1}{8}$ mm. in diameter, and making about 800 turns, is well adapted. Those for thermo-electric currents, where the E.M.F. is low, require a thicker and shorter wire; for example, thirty turns of a wire $\frac{3}{8}$ mm. in diameter. For very delicate experiments,

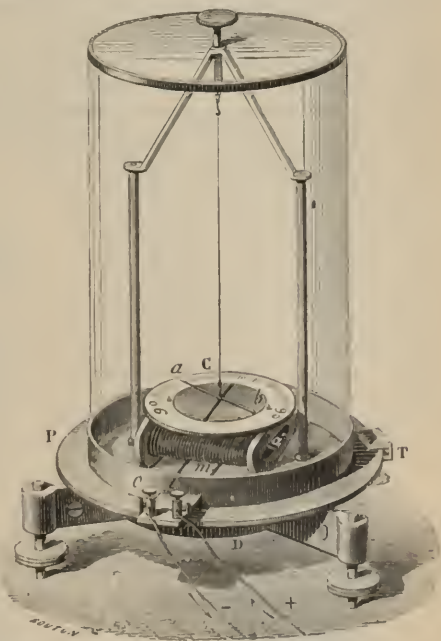

Fig. 830

as in physiological investigations, galvanometers with as many as 30,000 turns have been used.

By means of a delicate galvanometer consisting of 2000 or 3000 turns of fine wire, the coils of which are carefully insulated by means of silk and shellac, currents, such as those due to the electric machine, may be shown. One end of the galvanometer is connected with the prime conductor, or one electrode (fig. 736, or fig. 744), and the other with the ground or with the other electrode, and when the machine is worked the needle is deflected, affording thus an illustration of the identity of statical with dynamical electricity.

The deflection of the needle increases with the strength of the current ; there is, however, no simple law connecting the deflection of the needle with the strength of the current as there is in the sine and tangent galvanometers. For small deflections the current is proportional to the deflection, but increases in a greater ratio when the deflection exceeds about 10° . Each instrument must be separately *calibrated*, that is, known and increasing currents must be passed through it, and a curve drawn, called the *calibration curve*, showing the connection between deflection and current.

841. **Lord Kelvin's mirror galvanometer.**—This instrument differs in several important points from that last described, and is much more sensitive. Fig. 831 shows a section of the coil, which consists of a large number of turns of fine silk-covered copper wire wound on two circular bobbins which are clamped together, sufficient space being left between them for the suspension fibre. The needles of the astatic combination are strongly magnetised strips of thin steel watch-spring, about 2 mm.

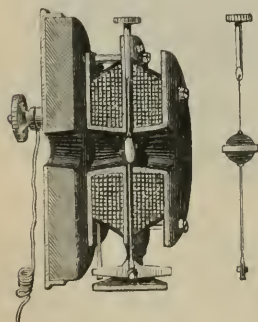

Fig. 831

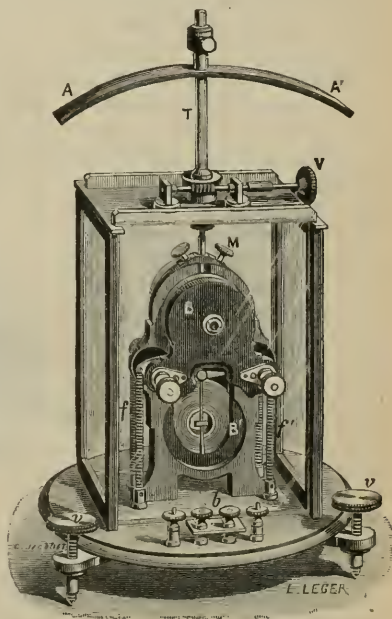

Fig. 832

broad and 10 or 12 mm. long. The upper one is cemented to the back of a concave spherical mirror, seen on the right of fig. 831, the lower needle being similar, and having a comparatively long strip of thin aluminium or

mica attached at right angles to it, to limit the motion of the system. The two needles are rigidly connected by a thin rod or wire of aluminium, and the suspension is a single fibre of silk. The motion of the needle is observed by the lamp and scale arrangement described in art. 532.

In the instrument represented in fig. 832 there are two coils, B, B'. Each needle of the astatic combination is in the centre of a bobbin, the coils being connected, so that the current goes round the two needles in opposite directions, and thus each is deflected in the same direction. The front portion of the lower coil is removed to show the needle inside, and the mirror is attached, not to either needle, but to the centre of the wire which connects them. AA' is a controlling magnet which can be moved vertically along the rod T, and is susceptible of a slow motion in azimuth by means of the tangent screw V. This arrangement allows us not only to vary the sensitiveness but to orient the needles parallel to the turns of wire in the bobbins, whatever position with regard to the meridian the instrument may be placed in. The resistance of the wire of galvanometers of this description is generally from 5000 to 10,000 ohms. The sensitiveness, or *figure of merit*, is specified sometimes in terms of the current required to produce a deflection of the spot of light over one division of the scale, sometimes in terms of the deflection produced by a given current, or again by the resistance which must be included in the circuit in order that an applied E.M.F. of one volt may produce a deflection of one division of the scale. The scale is generally one metre from the galvanometer. We may easily obtain a deflection of twenty divisions—under ordinary conditions—by a current of the one-thousandth of a micro-ampere, or 10^{-9} ampere (849). Since for small angles the deflection of the spot of light on the scale is proportional to the current, $C = kd$, k being a constant called the *reduction factor* of the instrument (838).

842. **Differential galvanometer.**—In the differential galvanometer two wires are wound side by side on each bobbin, each wire being independent of the other, so that the instrument has *four* terminals. The coils of the galvanometer shown in fig. 832 are wound in this way, the four terminals being seen at b in front. If we call these 1, 2, 3, 4, numbering from left to right, 1 and 2 are the terminals of one winding, 3 and 4 of the other. If the current enters at 1 it passes through half the wire on the bobbins B and B' and returns to 2; if it enters at 3 it passes through the other half and emerges at 4. Thus we may use either half of the galvanometer independently of the other. In the figure 2 and 3 are joined together by a copper strap, and the instrument is then an ordinary galvanometer, 1 and 4 being its terminals, and the current passing through *all* the wire. But if 2 and 4 are joined by a strap, and 1 and 3 are the terminals, the needles will not be affected, since the two windings are exactly equal to each other in all respects, and the current flows round them in opposite directions. Again, if two independent circuits are connected, the one to the terminals 1 and 2, the other to 3 and 4, so that the currents are opposed, the deflection will be proportional to the difference of the strengths of the currents in the two circuits. Hence the name of the instrument.

843. **Ballistic and dead-beat galvanometers.**—When a current is passed through a galvanometer, the needle, as a rule, only attains its final position after a number of oscillations of gradually diminishing amplitude; but if by

any means the motion of the needle is impeded or *damped*, the number of oscillations may be reduced. Damping may be effected either mechanically or electromagnetically—mechanically, by attaching to the needle or mirror, in the case of a single-needle instrument, a large mica vane, and enclosing the system in an airtight box, or, in the case of an astatic combination, by suspending a strip of sheet platinum to the lower needle, and immersing it in water or oil. Electromagnetic damping will be treated later (963), when we have dealt with the subject of induced currents. Instruments in which the damping is excessive—that is, in which, when a current passes, the needle moves to its final position, and when the current is stopped returns to zero, in each case without any oscillation—are said to be *dead beat*.

In a ballistic galvanometer, on the other hand, the damping is reduced to a minimum, the needles being shaped so as to give rise to no air friction, and the mirror being as small as possible. As the needle oscillates each amplitude is only slightly less than the preceding, and consequently the needle oscillates for a long time before coming to rest. The natural logarithm of the ratio of the amplitudes of two successive oscillations of the needle is called the *logarithmic decrement*, and is denoted by λ . The logarithmic decrement is proportional to the period of oscillation (t) of the needle, that is $\lambda = \epsilon t$, where ϵ depends upon the damping arrangement. Ballistic galvanometers are used for the measurement of a *quantity of electricity* or *electric charge*. For example, when a charged condenser (782) is discharged through a ballistic galvanometer, the needle receives, as it were, an impulsive blow, since the electricity passes through the coils before the needle—whose moment of inertia (89A) is rather large—has sensibly moved from its position of rest.

In these circumstances, theory shows that the quantity of electricity which has passed is proportional to the sine of half the angle of the first *throw* or *swing* of the needle, the formula being

$$Q = \frac{H}{G} \cdot \frac{t}{\pi} \cdot \sin \frac{\theta}{2},$$

in which Q = the quantity of electricity,

H = the earth's horizontal force,

t = the period of the needle (56),

G = the magnetic force at the centre of the coil due to the passage of unit current (837).

We have neglected any retarding influence due to the resistance of the air.

This formula, in which it is assumed that there is no damping, may be further simplified if the throw is small, for then $\sin \frac{\theta}{2} = \frac{\theta}{2}$,

$$\text{and } Q = \frac{Ht}{2\pi G} \cdot \theta \text{ in C.G.S. units,}$$

$$\text{or } = \frac{10Ht}{2\pi G} \cdot \theta \text{ in coulombs (930).}$$

Fig. 833 represents a ballistic galvanometer with astatic needles. The wire is wound on two bobbins attached to frames which are hinged together.

The needles are formed of cylinders of steel, about 3 or 4 mm. long, rounded at one end and saw-cut at the other, so as to form a sort of horseshoe with opposite poles on the two sides of the cut. Four of these are attached to an aluminium rod in two astatic pairs, two close together at the centre of the coil, and the two compensating ones, one above and one below the coil. The mirror seen just above the coil is a very small one. By means of the

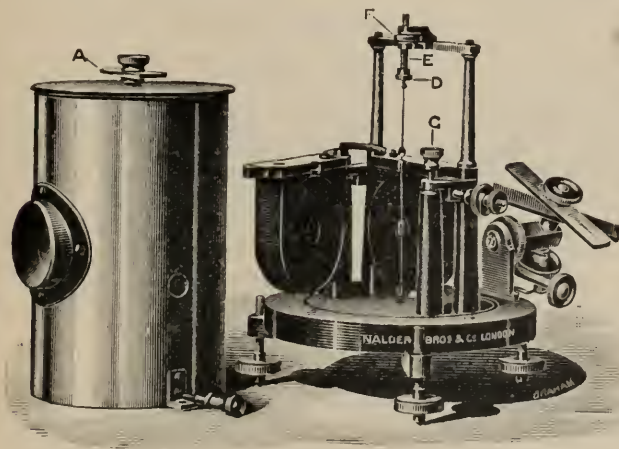

Fig. 833

two controlling magnets placed at the side, the period of the needle can be altered within wide limits; it usually is from 5 to 10 seconds.

An ammeter, or ampere-meter, is a galvanometer in which the strength of the current is read off directly in amperes. Ammeters are constructed on various principles, and will be described in the chapters in which these principles are explained.

CHAPTER III

OHM'S LAW

844. **The strength of a current is the same at all parts of a circuit.**—Whatever the conductors of which the different parts of a circuit may be composed, and however they may differ in length, diameter, or material, the quantity of electricity passing any section per second—that is, the electric current—is the same in all parts. If it were not so, there would necessarily ensue an accumulation of electricity at some parts of the circuit and a deficit at others, which is contrary to experience. But the statement may be proved experimentally by the apparatus shown in fig. 834, the current being measured by the magnetic field it produces.

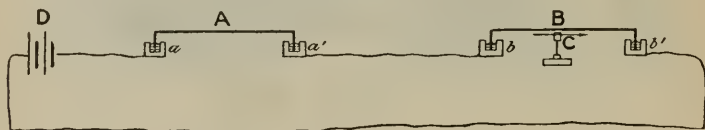

Fig. 834

A and B are two straight rods of the same length, provided with stout copper terminal pieces which dip into mercury cups, a, a', b, b' . A is a thick rod of copper, B a thin one of german silver, which is relatively a bad conductor, and the two are interchangeable in such a way that whichever of them is in the position B, its axis is the same distance from the magnetic needle C. When the circuit, containing a battery D, is completed, the needle is deflected, and the deflection is the same whether A or B occupies the mercury cups b, b' , showing that the strength of current in the thin bad conductor is the same as in the good conducting copper rod. The experiment may be made more sensitive by using not such a needle as is represented in the figure, but a small galvanometer needle suspended by a silk fibre, and noting the deflection of the spot of light reflected from a mirror attached to the needle.

845. **Ohm's law.**—For a knowledge of the conditions which regulate the action of the voltaic current, science is indebted to G. S. Ohm. His results were at first deduced from theoretical considerations; but by his own researches as well as by those of Fechner, Pouillet, Daniell, De la Rive, Wheatstone, and others, they received the fullest confirmation, and their great theoretical and practical importance has been fully established.

The law of conduction of heat through a conductor is given by the formula (411) $Q = k \frac{A(\theta - \theta_1)}{l} t$, where Q is the quantity of heat passing in

a time t through a cylinder of the material of the conductor, of length l and cross-section A , due to a difference of temperature $\theta - \theta_1$ between the ends. The constant k is called the specific thermal conductivity of the material.

If we assume, as Ohm did, that the flow of electricity through a conductor is analogous to the flow of heat—the cause of the flow in the one case being difference of electric potential, as it is in the other difference of temperature—the formula for the conduction of electricity is $Q = k_1 \frac{A(V - V_1)}{l} t$; in which A , l , and t have the same meanings as before, Q is the quantity of electricity which passes through the conductor in time t , due to the difference of potential $V - V_1$, and k_1 is a constant called the *specific electric conductivity* of the material of the conductor.

Since the strength of a current, C , is the quantity of electricity, Q , passing any cross-section of the circuit in unit time, $Q = Ct$, and the above formula becomes

$$Q = Ct = k_1 \frac{A(V - V_1)t}{l}$$

$$\text{or } C = \frac{V - V_1}{\frac{l}{Ak_1}} = \frac{e}{R},$$

where e is the difference of potential between the ends of the rod l , and R is the resistance of the rod. This formula expresses *Ohm's law*, which states that when two points, maintained at a difference of potential e , are connected by a conductor, a current C flows, which is directly proportional to the D.P., the ratio $\frac{e}{C}$ being called the resistance, R , of the conductor.

If $k_1 = \frac{1}{\rho}$, $R = \rho \frac{l}{A}$, or the resistance of a cylindrical conductor varies directly as its length and inversely as its cross-section; and, further, if $l = 1$ cm., and $A = 1$ sq. cm., $R = \rho$, which tells us that ρ , which is called the *specific resistance* or *resistivity* of the material, is equal to the resistance of a rod or bar of the material 1 cm. long and 1 sq. cm. in section. The practical unit of resistance is called an *ohm*; to the unit of electric conductance Lord Kelvin has given the name *mho*; $1 \text{ mho} = \frac{1}{1 \text{ ohm}}$.

The terms *resistance* and *conductance* are applied to conduction of any length and section; *resistivity* and *conductivity* are terms which refer to a specific property of a material, and when they are used, the unit length and unit cross-section are always implied.

The electromotive force, E , of a cell has been defined to be the difference of potential between its poles, as measured by a quadrant electrometer, or other electrostatic voltmeter, when the cell is on open circuit. When the poles are joined by a wire of resistance R , a current flows round the whole circuit—through the cell (of resistance r) as well as through the external wire. Since E represents the whole fall of potential throughout the circuit, part of it must take place in the cell and part in the wire, so that when the poles of the cell are joined by the wire R , the D.P. between them is no

longer E , but something less than E —call it e ; then $E - e$ is the D.P. causing the flow through the cell. Now the strength of the current is the same in all parts of the circuit, therefore by Ohm's law $C = \frac{e}{R}$ in the wire, and

$$= \frac{E - e}{r} \text{ in the cell : hence } C = \frac{E}{R + r}.$$

We thus arrive at the expression of Ohm's law *as applied to the whole of a simple circuit*. It is stated thus:—In any simple circuit the strength of the current is equal to the E.M.F. of the cell or battery divided by all the resistance in the circuit.

It has been observed (815) that a difference of opinion exists as to the seat of the electromotive force in a voltaic cell. We will assume (and the assumption, whether correct or not, will lead to no error) that the rise of potential which constitutes the E.M.F. of a cell occurs exclusively at the place of contact of the zinc and the acid (fig. 803); that, before the poles are joined, the acid, copper plate, and positive terminal are at one and the same potential, and the zinc and negative terminal also at one and the same potential, which is lower than the former by the electromotive force E . When the terminals are joined there is a fall of potential through the acid of the cell equal to $E - e$, and a further fall, equal to e , in the external wire from the copper to the zinc plate, where the potential again rises by E , and so on.

We may imagine, as an analogous case, a pump driving water from a source through a continuous system of pipes, some wide, some narrow, which deliver the water again to the source. The water circulates round and round, leaving the pump at high and returning to it at low pressure. The quantity of water passing any section of the circuit per second is the same for all sections. The energy required for the flow is that expended on the pump, as in the electric case it is that derived from the chemical action between the zinc and the acid.

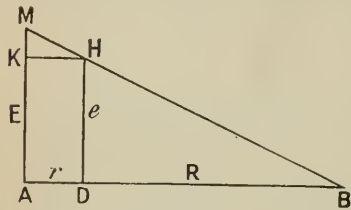

Fig. 835

Ohm's formula may be illustrated by a simple geometrical figure. Draw a straight line, AB (fig. 835), whose length represents the sum of the internal and external resistances in a simple circuit, AD being equal to r , the internal, and DB equal to R , the external resistance. At A draw AM at right angles to AB , of such a length as to represent the E.M.F. of the cell, and join MB . Then, if the angle

$$\angle ABM = \alpha, \tan \alpha = \frac{MA}{AB} = \frac{E}{R + r} = \text{also } \frac{HD}{DB} = \frac{e}{R} = \text{also } \frac{E - e}{r} = C.$$

MK represents the fall of potential through the cell, and HD that through the external resistance.

When r is small relatively to R , HD is nearly equal to MA ; and the error made in assuming e , the D.P. at the terminals of the cell, to be equal to E , the electromotive force, becomes less as r is made smaller relatively to R . For example, if the resistance of the cell is 0.1 ohm and the external resistance is 100 ohms, an error of only 1 in 1000 is made in assuming $e = E$.

846. **Particular cases of Ohm's law.**—If any number, n , of similar cells are joined together *in series* (fig. 836) there is n times the electromotive force, but at the same time n times the resistance of one cell; and the formula

$$\text{becomes } C = \frac{nE}{R + nr}.$$

If the external resistance is very small—which is the case, for instance, when it is a short thick copper wire—it may be neglected in comparison with the internal resistance, and then we have $C = \frac{nE}{nr} = \frac{E}{r}$; that is a battery consisting of several cells in series produces in this case no greater effect than a single cell.

If, however, the external resistance is very great, advantage is gained by using a large number of cells; for then, supposing that R is so large that nr



Fig. 836



Fig. 837

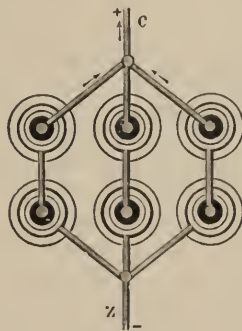

Fig. 838

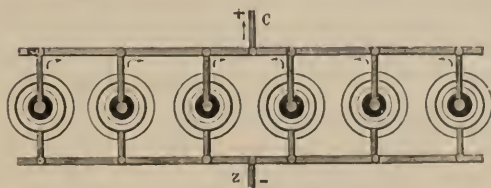

Fig. 839

may be neglected in comparison with it, the general formula becomes $C = \frac{nE}{R}$, that is, the current-strength, within certain limits, is proportional to the number of cells.

In the case of a thermo-electric pile (873) which consists of very short metallic conductors, or of a storage battery (947), the internal resistance is so small that it may generally be neglected, and the current-strength depends only on the external circuit.

Suppose, for example, $R = 12$ ohms, $r = 3$ ohms, and $n = 24$; then $\frac{R}{r} = \frac{12}{3} = 4$, and $\frac{s}{p}$ must be made as nearly as possible equal to 4. But the possible values of $\frac{s}{p}$ are $\frac{24}{1} (= 24)$, $\frac{12}{2} (= 6)$, $\frac{8}{3} (= 2\frac{2}{3})$, $\frac{6}{4} (= 1\frac{1}{2})$, &c.; of these, $2\frac{2}{3}$ is less, and 6 is greater, than 4, and therefore it is doubtful whether the cells should be arranged 12 or 8 in series. Applying Ohm's law, we find that both arrangements give the same current.

848. **Electromotive force.**—The units in which the magnitudes involved in Ohm's law are expressed have already been stated, but we may here enter into a little more detail with regard to them. The C.G.S. unit of electromotive force, or difference of potential, or *electric pressure*, on the electromagnetic system of units, is too small for practical use; the practical unit, or *volt*, is 10^8 , or 100,000,000, C.G.S. units. The method by which the electromagnetic unit of potential difference is arrived at will be given later (965), but it may be stated that this unit is small compared with the electrostatic unit, based on the attraction or repulsion of two small charges of electricity; indeed, the latter—the electrostatic unit— $= 3 \times 10^{10}$ electromagnetic units $= \frac{3 \times 10^{10}}{10^8}$, or 300 volts.

The prefixes *mega* and *micro* are employed generally to represent respectively a million times, and a millionth part of, the unit to which they are attached. Thus, a megavolt is a million volts, a microvolt a millionth part of a volt.

Differences of potential are measured electrostatically by an electrometer; electromagnetically by a suitable galvanometer, called a voltmeter, as will be explained later (925).

The volt is defined as that electric pressure which, if steadily applied to a conductor whose resistance is 1 ohm, will produce a current of 1 ampere. The standard of electromotive force is a Clark's cell (827), which when constructed in a specified manner, has an E.M.F. of 1.434 volt at 15°C .

849. **Currents.**—The magnetic force at the centre of a circular ring, traversed by a current C , is $\frac{2\pi r}{r^2} C$ (837), r being the radius of the ring.

If we consider the magnetic force at the centre as being produced not by the current in the whole ring, but by that in a portion of it equal to the radius, and if, further, the radius is 1 cm., the magnetic force at the centre is numerically equal to C . Thus the unit current will be that producing (under these conditions) unit force. Hence the definition of unit current on the C.G.S. electromagnetic system of units is as follows:—The unit current is that current which, traversing an arc of a circle equal to the radius (the radius being 1 cm.), produces at the centre of the circle the unit magnetic field. The practical unit, called *an ampere*, is the tenth part of the absolute unit. A microampere is the millionth part of an ampere; the term megampere is rarely required. The legal definition of an ampere is that it deposits 0.001118 gramme of silver from a silver nitrate solution, under specified conditions, in one second.

850. **Resistance.**—The practical unit of resistance is called an ohm. It is a thousand million, or 10^9 , C.G.S. units of resistance on the electromagnetic system. Megohm and microhm mean respectively a million ohms and the millionth part of an ohm. By Ohm's law, if a current of 1 ampere flows through a wire due to an electric pressure of 1 volt between its ends, the resistance of the wire is 1 ohm, or 1 ampere = $\frac{1 \text{ volt}}{1 \text{ ohm}}$.

The ohm is defined as 'the resistance offered to an unvarying current by a column of mercury, at the temperature of melting ice, 14·4521 grammes in mass, of a constant cross-sectional area, and of a length of 106·3 centimetres.' The cross-sectional area of the tube is 1 sq. mm. This unit was adopted by the International Congress at Chicago in 1893, and was legalised in England in 1894; it is 1·358 per cent. greater than the British Association or B.A. unit, 1 international ohm being equal to 1·01358 B.A. unit.

The resistance of a wire of uniform section = $\rho \frac{l}{s}$, l and s being the length and cross section of the wire respectively, and ρ the specific resistance or *resistivity* of its material. The statement that the specific resistance of copper is ·0000016 ohm, or 1·6 microhms, means that a cube of copper, 1 cm. along each edge, opposes a resistance of 1·6 microhms to the passage of electricity between opposite faces. In the following table are given the specific resistances (ρ) in microhms at 15° C. of a number of metals and alloys on the authority of Dewar and Fleming.

Metals	ρ in microhms at 15°	Temperature coefficient
Platinum	10·917	·00367
Gold	2·197	·00377
Silver	1·468	·00400
Copper	1·561	·00428
Aluminium	2·665	·00435
Iron	9·065	·00625
Nickel	12·323	·00622
Tin	13·048	·00440
Zinc	5·751	·00406
Lead	20·380	·00411
Alloys		
Platinum-silver (Pt ₃₃ Ag ₆₆)	31·582	·000243
Platinum-iridium (Pt ₈₀ Ir ₂₀)	30·896	·000822
Platinum-rhodium (Pt ₉₀ Rh ₁₀)	21·142	·001430
Gold-silver (Au ₉₀ Ag ₁₀)	6·280	·001240
Manganese steel (Mn12)	67·148	·001270
Nickel steel (Ni ₄ ·35)	29·452	·002010
German silver	29·982	·000275
Platinoid	41·371	·000310
Manganin (Cu ₈₄ Mn ₁₂ Ni ₄)	46·678	·000000
Silverin (Cu ₇₇ Ni ₁₇ Fe ₂ Zn ₂ Co ₂)	2·064	·002850
Aluminium-silver (Al ₉₄ Ag ₆)	4·641	·002380
Aluminium copper (Al ₉₄ Cu ₆)	2·901	·003810
Copper aluminium (Cu ₉₇ Al ₃)	8·847	·000897

The resistivity of an alloy is generally greater than that of a pure metal. The admixture of a small trace of impurity often materially increases the resistivity of a metal.

851. **Influence of temperature on resistance.**—The resistance of a metal increases as the temperature rises. If R_0 is the resistance of a wire of given material at 0° , its resistance R_t at t° is given approximately by the equation $R_t = R_0(1 + \sigma t)$, where σ is the temperature coefficient of the resistance of the material. The temperature coefficients of a number of metals and alloys are given in the preceding table (850). For pure metals (excepting the ferromagnetic metals iron and nickel) σ does not much differ from $\cdot 004$; the resistance of a copper wire, for example, which is 100 ohms at 0° , would be 100.4 ohms at 1° , 104 ohms at 10° , and so on.

The temperature coefficient of an alloy is generally less than that of a pure metal; that of platinoid, which is an alloy of copper and nickel, with a small admixture of tungsten, is only $\cdot 0003$, or about one-thirteenth that of pure copper; while the resistance of manganin is, within certain limits, independent of temperature. The temperature coefficient of carbon is negative, that is, carbon conducts better at a high temperature. The resistance of a glow-lamp when glowing is only about half what it is when the lamp is cold.

Recent researches of Dewar and Fleming show that at very low temperatures such as are obtained by the evaporation of liquid oxygen (386) the specific resistances are very much less than at ordinary temperatures. Their results give

	Platinum	Copper	Iron
0°	10974	1564	9115
-200°	3340	290	1220
-220°	2430	144	660

That is to say, the conductivity of iron at -220° C. is 14 times as great as it is at 0° .

852. **Resistance of liquids.**—The resistance of a column of conducting liquid of uniform section is given by the same formula as applies to a metallic wire, viz. $R = \rho \frac{l}{S}$, ρ being the resistivity of the liquid. Thus, the internal resistance of a voltaic cell depends upon the size of the plates, their distance apart, and the conductivity of the salts or acids employed in the cell. Although, therefore, the E.M.F. is independent of the size of a cell, the internal resistance diminishes as the size increases. The specific resistances of a few liquids in ohms per centimetre cube, at 15° , are given below.

Liquid	Resistivity in ohms per cm. cube
Copper nitrate, saturated solution	16.70
Copper sulphate	27.67
Zinc sulphate	26.00
Ammonium chloride	8.00
Sodium chloride	4.76
Sulphuric acid 1.1 sp. gr.	1.514
" " 1.24	1.130
" " 1.40	1.653
Distilled water	21,400

The last number was that found by Kohlrausch for distilled water, which had been specially purified. Accordingly, a disc of water a millimetre in thickness offers the same resistance as a column of silver of the same diameter, but of a length equal to that of the moon's orbit. The least trace of impurity in water markedly raises its conductivity: thus standing in the air for five hours doubles it; the addition of a millionth part of sulphuric acid—that is, a drop in about 17 gallons—increases the conductivity tenfold. Accordingly we may say in effect that perfectly pure water is not a conductor, and therefore is not appreciably decomposed by a current.

The conductivity of a salt solution depends on the concentration; for dilute solutions it increases with the strength, though not in direct proportion. For each solution there is a certain strength at which the conductivity is greatest; this strength, in many cases, is short of that at which the liquid is saturated. For copper sulphate this is 18 per cent., and for sodium chloride 26 per cent.

The conductivity of liquids increases with the temperature. The coefficient of increase for 1° C. varies within wide limits in the case of strong solutions of various substances—thus, from 0.0087 in the case of hydropotassic sulphate to 0.072 in the case of sodium hydrate. With dilute solutions, however, the limits are much narrower—from 0.0211 to 0.0233, or about six times as much as the corresponding coefficient for metals.

If two liquids are mixed, each of which conducts badly, for instance, alcohol and water each in a state of perfect purity, the conductivity of the mixture is greater than that of either of the constituents. Here we may suppose that each of the liquids acts as a diluent to the other, and thus favours the production of ions (934). A solution of sulphuric acid in water is one of the best liquid conductors known, although pure water and pure sulphuric acid conduct extremely badly.

853. **Divided circuits. Resistances in parallel.**—If an electric current flows between two points, A and B, in a conductor, the strength of the current, by Ohm's law, is equal to the D.P. between A and B, divided by the resistance of AB. Let A and B be joined by two conductors (fig. 840) whose resistances are r_1 and r_2 , and let e be the D.P. between A and B. Then, if C is the undivided

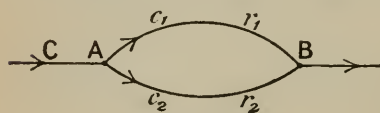

Fig. 840

current, and c_1 and c_2 the currents flowing through r_1 and r_2 , $C = c_1 + c_2$, and $e = c_1 r_1 = c_2 r_2$; $\therefore c_1 / c_2 = r_2 / r_1$, or the currents flowing through the two branches are inversely proportional to the resistances. Also, since $c_1 r_1 = c_2 r_2$,

$$\frac{c_1}{r_2} = \frac{c_2}{r_1} = \frac{c_1 + c_2}{r_1 + r_2} = \frac{C}{r_1 + r_2};$$

therefore

$$\frac{c_1}{C} = \frac{r_2}{r_1 + r_2}, \quad \frac{c_2}{C} = \frac{r_1}{r_1 + r_2}.$$

If R is a resistance equal to r_1 and r_2 combined, so that if r_1 and r_2 were

removed and replaced by R, no alteration of the current C would take place, then $C = \frac{e}{R}$. But

$$C = c_1 + c_2 = e \left(\frac{1}{r_1} + \frac{1}{r_2} \right);$$

hence,

$$\frac{1}{R} = \frac{1}{r_1} + \frac{1}{r_2}, \text{ or } R = \frac{r_1 r_2}{r_1 + r_2},$$

or, the sum of the reciprocals of the two resistances joining two points A and B is equal to the reciprocal of the equivalent resistance. It is easy to see that if A and B are joined by three or more resistances, r_1, r_2, r_3, \dots and R is the equivalent resistance,

$$\frac{1}{R} = \frac{1}{r_1} + \frac{1}{r_2} + \frac{1}{r_3} + \dots$$

854. Use of shunts.—The principle of divided circuits has an important application in *shunts*, by which any given proportion of a current may be transmitted through a galvanometer, so that a sensitive galvanometer suitable for currents measured in milli- or micro-amperes may be used for the measurement of much more powerful currents.

Fig. 841 shows how a shunt is applied to a galvanometer. The current C divides at the left-hand terminal of the galvanometer, part of it (c_1) traversing the galvanometer coils whose resistance = g , the other (c_2) flowing through a wire of resistance s joining the terminals.

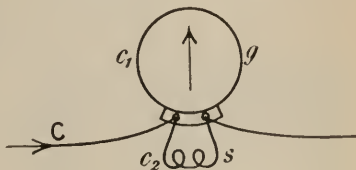

Fig. 841

We have seen (853) that $\frac{c_1}{C} = \frac{s}{s+g}$; and by making s sufficiently small, the proportion of the current $\left(\frac{c_1}{C}\right)$ which passes through the galvanometer may be reduced as much as we like. The expression $\frac{s+g}{s}$ is called the *multiplying power* of the shunt. As an example, suppose $g = 5000$ ohms, and we wish to provide a shunt which will enable one-thousandth part of the current arriving at the galvanometer to pass through its coils, the remaining 999 parts passing through the shunt. In this case

$$\frac{c_1}{C} = \frac{1}{1000} = \frac{s}{s+5000}, \text{ and } s = \frac{5000}{999} = 5.005 \text{ ohms.}$$

Fig. 842 represents a set of shunts whose resistances are $\frac{1}{9}$, $\frac{1}{99}$, and $\frac{1}{999}$ that of the galvanometer. G and G' are connected to the terminals of the galvanometer, and P P' with those of the battery. The gaps O, A, B, C can be closed by plugs, and thus the corresponding resistances introduced.

to neutralise the effects of self-induction (967) and of any extraneous inductive action. If the terminals of a circuit are connected with TT' (fig. 843), and all the plugs are inserted, the resistance box offers no appreciable resistance, for the current passes by the plugs and the massive metal; but by taking out any of the plugs the current has to pass through the wire coil between the two brass pieces, and thus its resistance is introduced. In fig. 844 the resistance unplugged is 74 ohms.

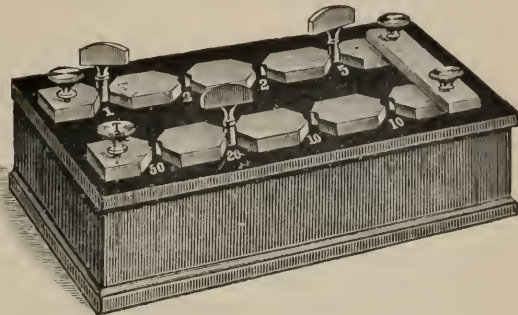

Fig. 844

The coils are in multiples and submultiples of ohms, and are so arranged that their combination may be as greatly varied with as few resistances as possible. Thus a set of twelve coils of 0.1, 0.2, 0.2, 0.5, 1, 1, 2, 5, 10, 10, 20, and 50 enables us to introduce any resistance from 0.1 to 100 into the circuit.

857. **Rheostat.**—A *Rheostat* is an instrument by which the resistance of any given circuit can be gradually increased or diminished without opening the circuit. The original form invented by Wheatstone consists of two parallel cylinders, one, A, of brass, the

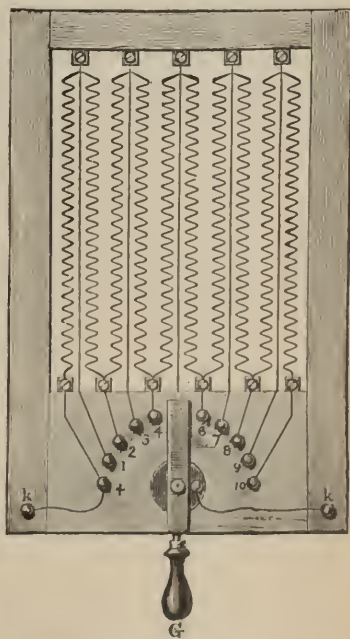

Fig. 846

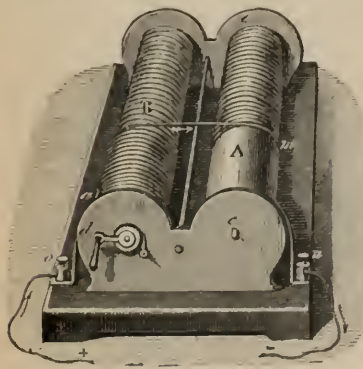

Fig. 845

other, B, of wood (fig. 845). In the latter there is a spiral groove, which terminates at *a* in a brass ring, to which is fixed the end of a fine brass wire.

This wire, which is about 40 yards long, is partially coiled on the groove ; it passes to the cylinder A, and, after a great number of turns on this cylinder, is fixed at the extremity *e*. Two binding screws *n* and *o*, connected with the battery, communicate by two steel plates ; one with the cylinder A, the other with the ring *a*.

When a current enters at *o*, it simply traverses that portion of the wire rolled on the cylinder B, where the windings are insulated by the grooves ; passing thence to the cylinder A, which is of metal, and in contact with the wire, the current passes directly to *m*, and thence to *n*. Hence, if the length of the circuit is to be increased, the handle *d* must be turned from right to left. If, on the contrary, it is to be diminished, the handle is to be fixed on the axis *c*, and turning then from left to right, the wire is coiled on the cylinder A. The length of the circuit is indicated in feet and inches, by two needles, at the end of the apparatus not seen in the figure, which are moved by the cylinders A and B.

Resistance frames are constructed, for dynamo work and large currents, in which the resistances are long spirals of thick uncovered iron or german silver wire freely exposed to the air so as to radiate heat rapidly. Iron wire is cheap, and its large temperature coefficient ($\cdot 006$) is no bar to its use for such purposes. Fig. 846 represents such a resistance frame ; the terminals are at *k* and *k*, the one on the right being connected with a metal spring having an insulated handle which can be moved backwards and forwards, and thus be placed in contact with any of the studs to which the resistances are connected. In this way, as can be seen from the figure, any number of resistances from 1 to 10 may be brought into the circuit, the spring being so wide that continuity is never broken.

CHAPTER IV

CONVERSION OF ELECTRIC ENERGY INTO HEAT

858. **Development of heat in a circuit.**—The E.M.F. of a cell is numerically equal to the work done when unit charge is carried once round a closed circuit including the cell. For if E is the E.M.F. of the cell, and e the D.P. between the terminals when joined, e by definition (758) is equal to the work done in the passage of unit charge through the external circuit, and similarly $E - e$ that done by the unit charge in passing through the cell; hence the total work is E . If the charge carried = Q , the work done is EQ . This product represents the electric energy of the circuit, which is entirely converted into heat unless the circuit contain motors or electrolytic cells, or other arrangements for transforming the energy. Since $E = CR$, and $Q = Ct$, the product EQ may be written CEt or C^2Rt , where C is the current-strength and R the resistance of the whole circuit. Thus the heat produced in a circuit of resistance R by a current C flowing for a time t varies as the resistance and as the square of the current.

If we consider only the external circuit, or any particular part of it whose resistance is r_1 , and the D.P. between whose ends is e_1 , the heat developed in this is $e_1Q = Cr_1 \times Ct = C^2r_1t$. Hence the relation—heat varies as C^2r_1t —applies not only to the whole circuit, but to any particular part of it, and therefore to the cell itself. The heat developed in any particular part of the circuit bears to that produced in the whole circuit the same ratio as the corresponding resistances. Hence to concentrate the heat in a particular part of a circuit, such as a fuse or a lamp, the resistance of the rest must be made as small as possible.

If the whole of the energy due to the chemical transformations in a cell is converted into electric energy, the only heat produced in a cell will be that due to the passage of the current, and will be equal to C^2rt , where r is the internal resistance. It may happen, however, that only a portion of the chemical energy is transformed into electric energy, the remainder passing into heat which will raise the temperature of the cell, and thus the heat developed in the cell will be greater than that corresponding to the given current. On the other hand, it may happen that the chemical energy of transformation does not suffice for the actual electric energy in the circuit, the deficit being made good by the abstraction of heat from the cell. In this case, then, the measured heat in the cell is less than that due to the current by the amount which is directly converted into electric energy. It may be shown from thermodynamic principles that

i. If the chemical and electric energies of a cell are equal, the E.M.F. of the cell is independent of temperature. This is practically the case with a Daniell cell.

ii. If the electric energy is less than the chemical energy, the E.M.F. of the cell will diminish with rise of temperature. This is the case with most cells.

iii. If the electric energy is greater than that corresponding to the chemical reactions of the cell, the E.M.F. will rise with rising temperature.

859. **Illustrative experiments.**—When a voltaic current is passed through a spiral of platinum wire, the leads from the battery being of thick copper, the wire becomes heated, and even incandescent if it is very short and thin. With a powerful current all metals are melted, even iridium and platinum, the least fusible of metals. Carbon is the only element which has not hitherto been fused by it, but carbon rods were raised by Despretz (using a Bunsen battery) to such a temperature that they were softened and could be welded together.

With sufficient current fine wires of lead, tin, zinc, copper, gold, silver, iron, and even platinum, may be melted and volatilised, with differently coloured sparks. Iron and platinum burn with a brilliant white light; lead with a purple light; the light of tin and of gold is bluish-white; the light of zinc is a mixture of white and gold; finally, copper and silver give a green light.

Wire fuses are used for exploding guncotton, gunpowder, &c., and for firing mines in military and mining operations. The fuses are made of fine platinum, or platinum-silver, wire, are about an eighth of an inch long, and have a resistance when cold of about 1 ohm.

If a current passes through a chain of alternate links of platinum and silver wire of equal sizes, the platinum becomes more heated than the silver from its greater resistivity (850); and with a suitable current the platinum may become incandescent while the silver remains dark. This experiment was devised by Children.

If a long thin platinum wire is raised to dull redness by passing a current through it, and if part of it is cooled down by being dipped in cold water, the resistance of the cooled part is diminished, the strength of the current increases, and the rest of the wire becomes brighter than before. If, on the contrary, a part of the feebly incandescent wire is heated by a spirit-lamp, the resistance of the heated part increases; the effect is the same as that of introducing additional resistance, the strength of the current diminishes, and the wire ceases to be incandescent in the non-heated part.

Radiation and convection of heat lower the temperature to which a wire is raised by the passage of a given current through it. A round wire is more heated by the same current than the same wire which has been beaten out flat: for the latter with the same section offers a greater surface to the cooling medium than the other. For the same reason, when a wire is stretched in a glass tube on which two brass caps are fitted airtight, and the wire is raised to dull incandescence by the passage of a current, the incandescence is more vivid when the air has been pumped out of the tube, because it now simply loses heat by radiation, and not by communication to the surrounding medium.

Similarly, a current which will melt a wire in air will raise it only to dull redness in ether, and in oil or in water will not heat it to redness at all, for the liquids conduct heat away more readily than air does.

From the above laws it follows that the heating effect is the same in a wire whatever be its length, provided the current is constant; but it must be remembered that by increasing the length of the wire we increase the resistance, and consequently, to maintain the current constant, we must apply a larger E.M.F.; further, in a long wire there is a greater surface, and hence more heat is lost by radiation and by conduction.

Another application of the heating effect is to what are called *safety fuses*, or *automatic cut-outs*. These are lengths of fusible wire or ribbon (copper, lead, tin, &c.) interposed in the circuit of the powerful currents used for electric lighting and the like. Their dimensions are calculated so that when the current attains a certain strength, the heat generated is sufficient to melt them and thus break the circuit. As this can be arranged with great accuracy, it is possible to protect any piece of apparatus from damage by too strong a current.

By means of a heated platinum wire, parts of the body may be safely cauterised which could not be got at by a red-hot iron; the removal of tumours and the like may be effected by drawing a loop of cold platinum wire round their base, making the wire hot by a current, and gradually pulling its ends together. It has been observed that when the temperature of the wire is about 600° C., the combustion of the tissues is so complete that there is no hæmorrhage; while at 1500° the action of the wire is like that of a sharp knife. For other purposes of this *galvanic cauterisation*, platinum wire coiled in grooves cut in a porcelain rod is used.

860. **Joule's law.**—The fact that the heat developed in a conductor by the passage of a current varies as C^2Rt , which we have deduced from theoretical considerations, was proved experimentally by Joule, and is known by his name. The apparatus required for the experimental proof of Joule's law consists of a coil of, say, German-silver wire, immersed in a water calorimeter, and connected with a battery and tangent galvanometer. When the current flows the coil communicates its heat to the water in the calorimeter, and the rise of temperature is noted by a sensitive thermometer, the water being kept in motion by a suitable stirrer, so that all parts of it are at the same temperature. If θ is the rise of temperature in a time t , the heat produced is $m\theta$ calories, where m is the mass of the water in grammes together with the water equivalent of calorimeter, stirrer, &c. A correction must be made for the heat lost by convection and radiation; this correction is found by observing the rate of cooling of the calorimeter at temperatures between the highest and lowest of the experiment. The deflection of the galvanometer is noted at equal intervals during the time t , and the mean value of the current deduced; the resistance of the wire is determined by Wheatstone's bridge (923) at the mean temperature of the experiment.

By repeating the experiment with different strengths of current and coils of various resistances, we may prove (as Joule did) that the ratio of heat produced to the product C^2rt is a constant.

Instead of measuring r , we may use the expression Cet , and measure e , the D.P. between the ends of the coil, by a suitable voltmeter, the

calorimetric part of the experiment being the same as before. Or, again, we may measure e and r , and use the formula $\frac{e^2}{r}t$.

If H denotes the heat produced in calories, and J the mechanical equivalent of heat (860), JH is the energy of the heat produced, and therefore $JH = C^2rt$.

In this equation $J = 4.2 \times 10^7$ ergs, and C and r are measured in C.G.S. units. If the current and resistance are measured in amperes and ohms respectively, and are denoted by C_1 , r_1 , then since 1 ampere = 10^{-1} of a C.G.S. unit of current, and 1 ohm = 10^9 C.G.S. units of resistance,

$$\therefore C = 10^{-1}C_1 \text{ and } r = 10^9r_1$$

$$\therefore JH = C^2rt = C_1^2r_1t \times 10^7$$

$$\therefore H = C_1^2r_1t \times \frac{10^7}{4.2 \times 10^7} = C_1^2r_1t \times \frac{1}{4.2},$$

which gives the heat (in calories) produced by the passage of a current of C_1 amperes for t seconds through a resistance of r_1 ohms.

The erg, the C.G.S. unit of energy, is very small. The *practical* unit of energy, called a *joule*, is 10^7 ergs, from which it follows that 1 calorie = 4.2 joules.

The rate of doing work is called *power* (62). If a machine is working at such a rate that one erg is done per second, the power of the machine is unity on the C.G.S. system. If 10^7 ergs, or 1 joule, is done per second, the power of the machine is 1 *watt*. This is the *practical* unit of power; 1 horse-power = 746 watts. If practical units are employed, C^2Rt or CEt represents energy in joules, and C^2R or CE represents power in watts. If 1 ampere is passing through a conductor between two points whose D.P. is 1 volt, the power absorbed is 1 watt. The power of dynamos is generally expressed in *kilowatts*, a kilowatt being 1000 watts, or $1\frac{1}{3}$ horse-power very nearly.

861. **Graphical representation of the heating effects in a circuit.**—The law representing the production of heat in a circuit in the unit of time

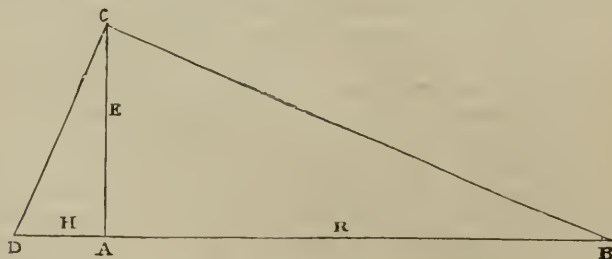

Fig. 847

is very well seen by the following geometrical construction, due to Carey Foster.

The heat produced in a circuit in the unit of time is proportional to the square of the strength of the current C , and to the resistance R , that is

$C^2R = H$, where H is the heat per second expressed in dynamical units ;

but since $C = \frac{E}{R}$ (845), we have $H = \frac{E^2}{R}$.

Draw a straight line DAB (fig. 847), and from any point A in it draw a line AC at right angles to DAB , and of a length proportional to the electromotive force of the cell. Lay off a length AB proportional to the resistance of the circuit. Join CB , and at C draw a line at right angles to BC , and let D be the point where this line cuts the line DAB . Then the length AD is proportional to the *heat* produced in the whole circuit in unit time. For the triangles ADC and ACB are similar, and therefore $AD : AC = AC : AB$; that is, $AD = \frac{AC^2}{AB}$; that is, $H = \frac{E^2}{R}$.

The above construction holds good if R and E , instead of being the resistance of the whole circuit and the E.M.F. of the battery, are respectively the resistance of any part of the circuit and the potential difference at the ends of this part.

If AC represents the E.M.F. of the circuit in volts, and AB the resistance in ohms, then AD represents the heat in the circuit in joules.

862. **Relation of heating effect to work of a battery.**—In every closed circuit containing a battery, chemical action is continuously going on ; the most common action is the solution of zinc in sulphuric acid, which may be regarded as an oxidation of the zinc to form zinc oxide, and a combination of this zinc oxide with sulphuric acid to form water and zinc sulphate. It is a true combustion of zinc, and this combustion serves to maintain all the actions which the circuit can produce, just as all the work which a steam-engine can effect has its origin in the combustion of fuel (481).

By independent experiments it has been found that, when a given weight of zinc is dissolved in sulphuric acid, a certain definite measurable *quantity* of heat is produced, which, as in all cases of chemical action, is the same, whatever be the rapidity with which the solution is effected ; the potential energy of chemical affinity of zinc and acid is converted into heat energy. If this solution takes place while the zinc is associated with another metal so as to form a voltaic cell in a circuit, the rapidity of the solution will be altered and the whole circuit will become heated—the liquid, the plates, the containing vessel as well as the connecting wire. In this case, as has been already pointed out (858), the energy of chemical affinity is transformed, partially or wholly, into the energy of electric current, which is again transformed into heat in the different parts of the circuit.

If the cell is made to do external mechanical work, the case is different. Joule made the following interesting experiment :—A small zinc and copper cell was arranged in a calorimeter, and the amount of heat determined while the poles were joined for a certain length of time by a short thick wire. The cell, still contained in the calorimeter, was next connected with a minute electromagnetic motor (993), by which a weight was raised. It was then found that the heat produced in the calorimeter in a given time—while, therefore, a certain amount of zinc was dissolved—was less while the motor was in action than when it was not ; and the amount of this diminution was the exact thermal equivalent of the work performed in raising the weight (566).

That the whole of the chemical work and disengagement of heat in the circuit of an ordinary cell has its origin in the solution of zinc in acid is confirmed by the following experiment, due to Favre :—

In one of the muffles of his calorimeter (470), five small zinc-platinum-acid cells were introduced; the other muffle contained a voltameter. Now when the circuit was closed until one equivalent of zinc was dissolved in the whole of the cells, $\frac{1}{3}$ of an equivalent of water should be decomposed in the voltameter (933), which was found to be the case. In one experiment the battery-circuit was closed without inserting the voltameter, and the heat disengaged during the solution of one equivalent of zinc was found to be 18,796 thermal units; when, however, the voltameter was introduced, the quantity disengaged was only 11,769 thermal units. Now the difference, 7027, is represented by the chemical work of decomposing $\frac{1}{3}$ of an equivalent of water: this agrees very well with the number, $6892 = \frac{34,462}{5}$, which represents the heat disengaged during the formation of $\frac{1}{3}$ of an equivalent of water (491).

However complicated may be the chemical processes involved in a voltaic combination, the total heat produced in it is the sum of the quantities of heat which are produced and absorbed in these various chemical processes, always supposing that no work is done in the circuit.

863. The electric arc.—If two rods of carbon are connected with the terminals of a battery or dynamo giving about 40 or 50 volts, and the round ends are brought into contact, the current passes but no spark occurs, for a D.P. of this amount is incompetent to produce a spark in air. When the carbons are separated by about one-tenth of an inch an arc of violet-coloured light is formed between them, and the ends of both become brightly incandescent, the positive much more than the negative.

Davy first made the experiment of the electric light in 1801, by means of a battery of 3000 plates, each four inches square. He used charcoal points made of light wood charcoal which had been heated to redness, and immersed in a mercury bath; the mercury penetrating into the pores of the charcoal increased its conductivity. When any substance was introduced into the electric arc produced by this battery, it became incandescent; platinum melted like wax in the flame of a candle; sapphire, magnesia, lime, and most refractory substances, were fused. Fragments of diamond, of charcoal, and of graphite rapidly disappeared without undergoing any previous fusion.

When the carbon rods are brought into contact a strong current flows. Just before separation the resistance is very great, and the carbon is raised to a high temperature, and a portion of it converted into carbon vapour, which is a sufficiently good conductor to allow a steady current to flow through it. The temperature necessary for the volatilisation of the carbon is not reached at the extremities of both rods, but only on the positive, the temperature of the negative terminal being always considerably lower.

The length of the electric arc—that is, the distance between the carbons—varies with the kind of carbon, and with the E.M.F. applied; under ordinary conditions it is about 3 mm.

The temperature and luminosity of the electric arc are chiefly due to the

direct conversion of electric energy into heat, but are partly derived from combustion of the carbon in air. The volatilisation of the positive carbon gives rise to a cup-shaped depression or *crater* at its end, the exact shape of which depends upon the length of the arc. The negative carbon, chiefly owing to combustion, assumes a conical shape; if the arc is formed *in vacuo*, so that combustion is prevented, the negative carbon is actually built up by the deposition upon it of condensed carbon vapour from the positive pole. In consequence of the rapid vaporisation, the positive pole wastes about twice as fast as the negative; hence for large currents the positive carbon should be thicker than the negative.

A thin layer of carbon vapour, with probably a high specific resistance, separates the crater from the *arc* proper, which has a bulbous shape and violet colour, and which consists of conducting carbon particles condensed from the vapour. The region round the arc in which combustion is going on is distinguished by a greenish flame. Of the light of the electric arc 85 per cent. comes from the positive carbon, 10 from the negative, and only 5 from the arc proper; for, although the temperature of the latter is high, its emissive power is feeble. The brightest part of all is the interior of the crater, the temperature of which, according to the estimate of Rossetti, is not less than 3500° C. The temperature of the negative carbon is between 2100° and 2500° .

It has been shown by Violle that the brightness of the crater, that is, the amount of light emitted by unit area of it, is practically the same when the power supplied to the arc is raised sixty-fold, and is independent of the size of the carbons and of the length of the arc. The effect of increasing the current, with given carbons at a given distance apart, is to increase the size of the crater, so as to increase the amount of light emitted, but not to increase the amount per unit of area. This is what we should expect if the temperature of the crater is that of the volatilisation of carbon; for this temperature could not be exceeded, provided the pressure remained constant, however greatly the power applied was increased, just as we cannot raise the temperature of boiling water by using a more powerful source of heat.

To maintain a steady arc between carbon points, it is necessary to employ an E.M.F. of more than 40 volts; generally from 45 to 50 are used. The necessity for this high electromotive force is generally explained by assuming that there is a *back E.M.F.* of something like 39 volts, whose seat is at the crater in the positive carbon, where a large amount of energy is necessary for the vaporisation of the carbon. This back E.M.F. is analogous to that which we meet with in a water voltmeter (933) or an electromagnetic motor. The high apparent resistance of the arc, obtained by dividing the D.P. by the current, is due to this back E.M.F. The true resistance of an arc of 3 mm. is something less than half an ohm. Mrs. Ayrton suggests that the film of carbon vapour close to the crater has a relatively high specific resistance, and may account for the high temperature of the crater without the necessity of assuming a large back E.M.F.

If the carbons are too far apart, or too close together, the arc is noisy and fluctuating. If the distance between them is too great, the arc flares and flickers from side to side and the chemical combustion is increased,

with the result that the electric efficiency is reduced when the distance is too small, the illuminating power of the arc is reduced by each carbon acting as a screen for the other, and the crater is diminished in size.

With alternating currents—which are largely used for the production of the electric light—there is no crater, and the two carbons are consumed at the same rate, each maintaining a rounded appearance.

Formerly carbons for the electric light were made of gas-retort carbon. They are now carefully prepared, and impurities excluded as far as possible.

Pure carbon, obtained by the destructive distillation of some such organic substance as coal tar or bitumen, is mixed with powdered graphite from the gas retorts, and made into a paste with sugar syrup or gum. This paste is forced under pressure through a die plate, and the rods so formed dried and baked. When simple gas-retort carbon is used, the impurities contained in it are fused and collect in bright beads on the surface of the carbon, presenting the appearance, when the arc is thrown on the screen by a lens, shown in fig. 848.

Cored carbons have an axial small core of carbon mixed with other substances to render it more volatile. They are used for positives, the object of the core being to keep the crater central.



Fig. 848

The candle-power of an arc lamp depends, of course, upon the current and E.M.F. used. If $C = 15$ amperes, and $E = 50$ volts, the power

expended is 750 watts, or about 1 horse-power. In these circumstances the lamp gives about 1000 candles, or 75 watts is required to produce the light of one candle.

864. Regulators of the electric light.—When the electric light is to be used for illumination, it must be as continuous as that of other sources. Hence, not only must the current be constant, but the distance of the carbons must not alter, which necessitates the use of some arrangement for automatically bringing them nearer together in proportion as they wear away. One of the best modes of effecting this is by an apparatus invented by Duboscq.

In Duboscq's regulator the two carbons are movable, but with unequal velocities, which are virtually proportional to their waste. The motion is transmitted by a drum placed on the axis xy (fig. 849). This turns, in the direction of the arrows, two wheels, a and b , the diameters of which are as $1 : 2$, and which respectively transmit their motion to two rackworks, C' and C . C lowers the positive charcoal, p , by means of a rod sliding in the tube H , while the other C' raises the negative charcoal, n , half as rapidly. By means of the milled head y the drum can be wound up, and at the same time the positive charcoal moved by the hand; the milled head x moves the negative charcoal also by the hand, and independently of the first. For this purpose the axis, xy , consists of two parts pressing against each other with

some force, so that, while the milled head *x* is held between the fingers, the other, *y*, may be moved, and by holding the latter we may move the former. But the friction is sufficient when the drum works to move the two wheels *a* and *b* and the two rackworks.

The two carbons being placed in contact, an E.M.F. of about 50 volts is applied to the apparatus by means of the wires *E* and *E'*. The current rising in *H* descends by the positive carbon to the negative, and reaches the bobbin *B*, which forms the foot of the regulator, and passes into the wire *E'*. The racks and wheelwork are carefully insulated from the current. By means of the milled head *x*, the carbons are then separated to give a steady arc. Inside the bobbin *B* is a bar of soft iron, which is magnetised as long as the current passes in the bobbin, and demagnetised when it does not pass, and this temporary magnet is the regulator. It acts attractively on an armature of soft iron, *A*, open in the centre so as to allow the rackwork *C* to pass, and fixed at the end of a lever, which works on two points, *mm*, and transmits a slight oscillation to a rod, *d*, which, by means of a catch, *i*, seizes the wheel *z*, as is seen on a larger scale in fig. 850. By an endless screw, and a series of toothed wheels, the stop is transmitted to the drum, and the rackwork being fixed, the same is the case with the carbons. This is what takes place so long as the magnetisation in the bobbin is strong enough to keep down the armature *A*; but in proportion as the carbons wear away, the current becomes feebler, though the arc continues, so that ultimately the attraction of the magnet no longer counterbalances a spring *r*, which continually tends to raise the armature. It then ascends, the piece *d* disengages the stop *i*, the drum works, and the carbons come nearer; they do not, however, touch, because the strength of the current gains the upper hand, the armature *A* is attracted, and the carbons remain fixed. As their distance

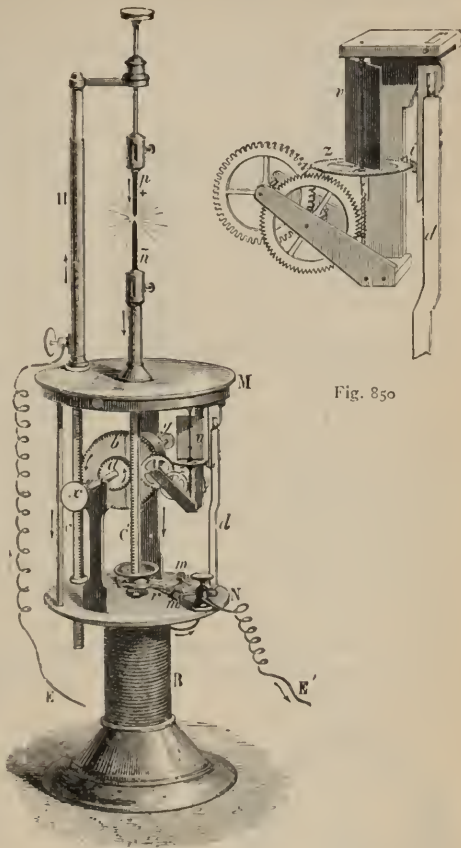

Fig. 849

Fig. 850

As their distance

only varies within very narrow limits, a regular and continuous light is obtained with this apparatus until the carbons are quite used

Von Hefner's differential regulator is represented in fig. 851; the current arriving by A divides at i (853); one portion passing through a fine wire coil, R, offering a large resistance, and the other through a short thick coil

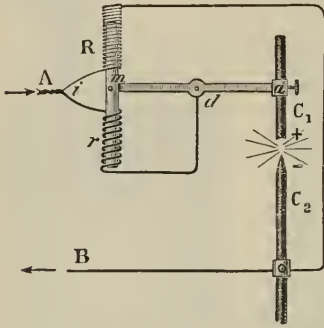

Fig. 851

r , whence it passes to a lever which turns about d ; to this is connected at one end, m , a soft-iron core which plays in the two coils, and at the other end is the positive carbon C_1 .

When the carbons are apart a great resistance is presented, and the current passes through R, so that the core is drawn within R, and the lever, and with it the carbon C_1 , falls; the fastening in the holder a is such that at a certain angle the carbon C_1 slips in the holder and touches the lower one, and the current passes by r d C_1 C_2 B; the

iron core is then drawn down, but the holder a moves up, grips the carbon, which it moves with it, and the arc is reproduced; when its normal length is attained its resistance increases to an amount such that the currents passing through the two coils now balance themselves, and their attraction on the iron being equal the core is stationary. Several such lamps may be arranged in a circuit, and the extinction of one of them does not affect the others.

865. **Incandescent lamps.**—Incandescent lamps, though not so economical as arc lights, lend themselves best to the distribution of the electric light.

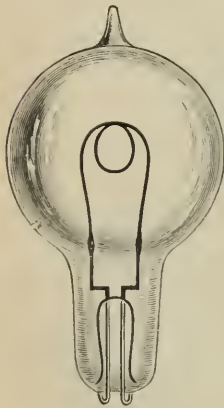

Fig. 852

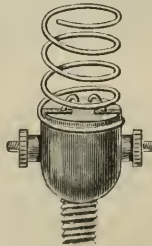

Fig. 853

We have seen that when a strong current of electricity is passed through a wire of small conductance (845), its temperature is raised to incandescence; if the strength of the current is increased, the brightness of the light increases, but in a greater ratio than the strength of the current. At such high temperatures, however, wires even of the most difficultly fusible metals fuse or are disintegrated; and the only material which does not fuse at the highest temperature is carbon. The first lamps in which this material was applied were constructed independently

by Edison in America and Swan in this country. The carbon filament of an incandescent or glow lamp may have any shape, but is ordinarily a single or

double loop with straight legs (see fig. 852). It is made in various ways, of which we will describe one. Cotton thread such as is used for crocheting is *parchmentised* by being passed through sulphuric acid of a certain strength, and afterwards carefully washed to remove all traces of the acid. The acid acts on the fibres of the cotton, destroys its structure, and reduces it to a semi-transparent gelatinous state. It is then passed through a draw plate to ensure uniformity of section, and wound on a frame of a shape the completed filament is intended to take. The next stage in the process is the carbonisation of the cellulose filaments, which is effected by raising them, packed on their frames in plumbago crucibles, to a white heat in a suitable furnace and allowing them slowly to cool. The material is thus converted into hard brittle carbon. The ends of the filament have now to be attached to the platinum wires which pass through the bottom of the lamp. One way of doing this is to flatten out the ends of the platinum wires and bend them round into a tubular form for the reception of the filament ends. The junctions are then dipped into some carbonaceous liquid, and an electric current passed through them by the aid of a metallic short-circuiting piece. The junctions are heated by the current, carbon is deposited, and firm permanent contact established between the filament and the platinum wire. The filament so formed and mounted is not of perfectly uniform diameter, although the cellulose was passed through a draw plate, and when it is traversed by a current will give out more light at the thinner than at the thicker parts. To obtain uniformity of section the process of *flashing* is employed; it consists in placing the filament in an enclosure which contains some hydrocarbon gas (*e.g.* olefiant gas) and raising it temporarily to incandescence by a current. The gas is decomposed at the high temperature into carbon and hydrogen, and the carbon is deposited at the thinnest parts where the temperature is highest. Thus uniformity of section is secured. Even if there are no irregularities in the section of the filament the process of flashing is useful, since the deposit of carbon reduces the resistance of the filament; and by repeated applications of the process the resistance can be reduced to a standard value. The deposited carbon also diminishes the brittleness of the filament and modifies its radiating power. The glass base carrying the platinum wires to which the filament is attached is now fused into the bulb, which is exhausted to a high degree by a mercury pump. Figs. 852, 853 show one of the modes of connecting the lamps to a source of electricity. The two platinum wires are bent outside in loops; these can be easily fitted in the two bent wires in the holder, which are in contact with the binding screws. The spring wire exerts an upward pressure so as always to ensure good contact.

The length and thickness of the carbon filament are determined by the electromotive force or voltage to be applied to the lamp and the illuminating power (candle-power) it is required to have. The voltage and candle-power are generally engraved on the outside of a glow lamp.

If we surround an electric light in one case by an opaque calorimeter, which therefore absorbs the entire radiation, and afterwards by a transparent one, which allows the light to pass, it will be found that the luminous radiation is about 10 per cent. of the total in the case of arc lamps and 5 in that of incandescent lamps.

The life of an incandescent lamp, or the number of hours it can maintain illumination, depends chiefly on the strength of current passed through it; under normal conditions it should be from 1000 to 2000 hours. If the current is very strong the life of the lamp is shortened, but the illuminating power varies in a greater ratio than the current. The *efficiency* of an electric lamp is generally given in terms of the watts required to produce 1-candle power. An incandescent lamp may be taken to absorb from 3.5 to 4 watts per candle; an arc light is much more efficient as it gives one candle at the expense of less than 1 watt.

The *Nernst lamp* consists of a rod of magnesia, or of magnesia mixed with other refractory oxides, which is rendered brilliantly incandescent by the passage of a current through it. At ordinary temperatures magnesia is a nonconductor of electricity, but acquires conducting power when its temperature is sufficiently raised. This may be effected by means of a spirit lamp, but more frequently by surrounding the rod with a coil of wire through which a current is passed, the coil being cut out of the circuit as soon as the magnesia becomes a conductor.

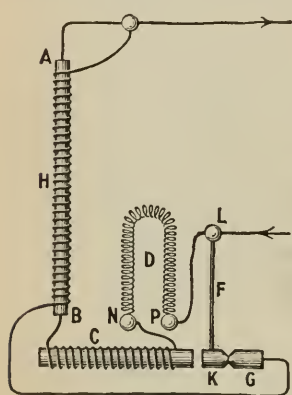

Fig. 853A

The arrangement by which this is done is shown diagrammatically in fig. 853A. AHB is the magnesia rod, C an electromagnet, and K a small mass of iron attached to a spring F which keeps it in electric contact with the fixed piece G, until it is pulled away by the attraction of the electromagnet. The current enters at L, and at first, since the cold magnesia rod is a non-conductor, passes by F, K, and G, to the wire surrounding the rod, and so back to the source. The rod AB is gradually heated by the current in the coil H (which envelops the magnesia rod, but is a little distance from it), and begins to conduct, the current in the coil of the electromagnet increases in strength, and presently the core is sufficiently magnetised to draw the armature K away from G. The current has then only one path, viz. that through the magnesia rod, which glows brilliantly. In circuit with the rod is the fine spiral iron wire D, the function of which is to steady the current. Owing to the high value of the temperature-coefficient (850) of iron, an increase of current beyond a certain point is checked by the increased resistance of the iron wire. This wire is enclosed in a sealed glass tube containing nitrogen gas to prevent oxidation of the iron.

From thirty to ninety seconds are required from the moment the current is switched on for the proper incandescence to be attained. This is one of the disadvantages of the lamp. The efficiency of the Nernst lamp is stated to be twice that of the carbon filament lamp.

866. **Electric furnace.**—It is probable that the temperature which can be produced by the oxyhydrogen flame is limited and has been already reached, and that we must look to the electric arc for the production of

higher temperatures than those at which carbonic acid and water are decomposed. Direct experiments by Siemens with the electric arc showed not only that it produces a very high temperature within a contracted space, but also that it will conveniently and economically produce such larger effects as will render it useful for many purposes in the arts, like the fusion of platinum and steel. He constructed an arrangement by which the electric arc was formed within a crucible made of the most refractory materials; the one electrode passed through the bottom of the crucible and the other through the lid, and there was an arrangement by which the distance of the electrodes could be automatically regulated; another important point was to constitute the positive pole of the material to be fused, as it is at this pole that the heat is principally developed. The arrangement formed, in short, an *electric furnace*. A dynamo machine capable of producing a current of 36 amperes, and with carbons capable of yielding a light equal to 6000 candles, fused a kilogramme of steel within half an hour. Siemens calculated that the heat in his furnace represented one-third of the horse-power expended in working the machine; and as a good engine utilises only about one-sixth of the combustible value of the coal employed in working it, it follows that the electric furnace utilises one-eighteenth of the energy residing in the fuel under the engine. The electric furnace is theoretically more economical than the ordinary air furnaces. Not only is the furnace thus a source of intense heat, but in certain operations the reducing action of the electrodes plays an important part, as in Cowles's method for the direct production of aluminium bronze. A charge of 35 kgr. powdered *corundum*, an aluminous mineral, mixed with powdered charcoal and twice its weight of granulated copper, was placed between carbon electrodes in a suitable vessel. On passing a powerful current the alumina was reduced and united directly with the copper to form aluminium bronze. The current actually employed was one of 5000 amperes with an E.M.F. of 50 volts, or a power of 250 kilowatts. The current was continued for an hour and a half, and produced about 82 kgr. of the alloy. Each kgr. of aluminium in the alloy represents a work of 44 horse-power for an hour.

Heroult's furnace, represented in fig. 854, consists of a cast-iron case lined on the inside with bricks made of carbon agglomerated by coal tar; this constitutes a conducting and refractory lining A, and is closed by a lid of graphite KK. The material to be treated is introduced by apertures *n, n*, and through a square central aperture; the positive pole is formed of a series of carbon plates, *bb*. The negative pole is connected with the frame *a*, and the lining A. By an aperture C, closed by a plug of carbon, the products of the action may be drawn off when the operation is finished.

A very remarkable application of the fusing power of the electric arc has been made to tunnelling apparatus, the electric flame being utilised to fuse the solid rock against which it is caused to impinge.

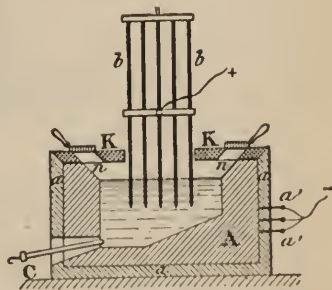

Fig. 854

867. **Hot-wire instruments.**—When a current of C amperes flows through a wire of resistance R ohms, the difference of potential, E , between its ends is CR . Since the rate of production of heat in the wire is C^2R or $\frac{E^2}{R}$, we may make use of the elongation of the wire, due to its rise of temperature, for the purpose of measuring either C or E , provided that the change of resistance of the wire is known or can be allowed for. Instruments based on this principle are known as *hot-wire* ammeters or voltmeters, as the case may be; they have the advantage that their indications are independent of the direction of the current, as they depend upon C^2 or E^2 , and may therefore be used for alternating as well as for direct currents. One of the best known is *Cardew's voltmeter*, which consists essentially of a long and very fine wire of platinum-silver, stretched by a spring to which is attached a multiplying motion and an index, the whole being inclosed in a brass tube for protection. The scale is graduated empirically. The two points where D.P. is to be measured being connected to the terminals of the instrument, the wire becomes heated to an extent proportional to the square of the D.P., and the motion of the index is a measure of this heating. In recent years more compact instruments based on the same principle have been constructed by various makers.

CHAPTER V

THERMO-ELECTRICITY

868. **Thermo-electricity.**—In 1821, Seebeck found that by heating one of the junctions of a metallic circuit, consisting of two metals soldered together, an electric current was produced. This phenomenon may be shown by means of the apparatus represented in fig. 855, which consists of a plate of copper, *mn*, the ends of which are bent and soldered to a plate of bismuth, *op*. Inside the circuit is a magnetic needle, *a*, moving on a pivot. When the apparatus is placed in the magnetic meridian, and one of the solderings gently heated, as shown in the figure, the needle is deflected in a manner which indicates the passage of a current from *n* to *m*—that is, from the heated to the cool junction in the copper. If, instead of heating the junction *n*, we cool it by ice, or by placing upon it cotton-wool moistened with ether, the other junction remaining at the ordinary temperature, a current is produced, but in the opposite direction—that is to say, from *m* to *n*; in both cases the current is in general stronger in proportion as the *difference* in temperature of the solderings is greater.

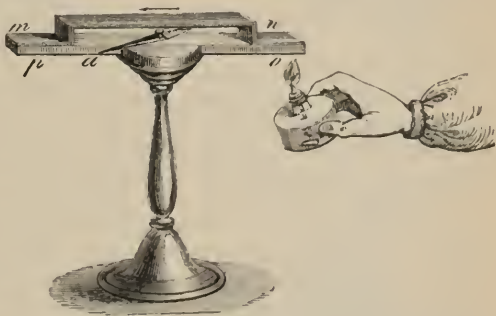

Fig. 855

Seebeck gave the name *thermo-electric* to this current, and to the couple which produces it, to distinguish it from the ordinary voltaic current and couple.

869. **Thermo-electric series.**—If small bars of two different metals are soldered together at one end while the free ends are connected with the wires of a galvanometer, and if the point of junction of the two metals is heated, a current is produced, the direction of which is indicated by the deflection of the needle of the galvanometer. Moreover, the strength of the current, calculated from the deflection of the galvanometer, is proportional to the electromotive force of the *thermo-couple*. By experimenting in this way with different metals, we may form them into a list such that the current passes from any one to another lower in the list through the hot junction.

The E.M.F. in a circuit of two metals depends upon the difference of temperature of the junctions and upon the nature of the substances employed ; it also depends upon the *mean* temperature of the junctions. If the mean temperature of the junctions of two metals is t° and one junction is half a degree above, the other half a degree below t° , so that the difference of temperature is one degree, the electromotive force in the circuit is called *the thermo-electric power* of the two metals at t° .

If P denotes the thermo-electric power of two metals at the mean temperature t° , and τ is the difference of temperature between their junctions, the E.M.F. acting on the circuit is $P\tau$.

Thermo-electric power is thus the rate of change of the thermo-electromotive force with temperature. The following table gives approximately the thermo-electric powers for certain metals at the mean temperature 20° C. They are expressed in micro-volts (848) per degree, and are referred to that of lead as zero.

Bismuth	+ 97	Copper	- 1
Cobalt	22	Silver	- 2.5
Nickel	22	Iron	- 14
German silver	12	Antimony	- 25
Lead	0	Tellurium	- 500
Tin	- 1	Selenium	- 800

Thus with whatever metal in the above list bismuth is associated to form a thermo-couple, the current will always pass from it to the other metal through the warmer junction. With a bismuth-antimony couple at a mean temperature of 20° , the E.M.F. per degree is $97 - (-25) = 122$ micro-volts.

It will be observed how great is the thermo-electric power of the highly crystalline metals. Alloys are not always intermediate to the metals of which they are composed, and therefore the position of the metals is greatly affected by slight admixtures. The thermo-electric behaviour of substances is greatly affected by hardness, direction of crystallisation, and so forth, and to this are no doubt due many of the discrepancies in the lists given by different observers.

Of all the bodies mentioned in the above series, bismuth and selenium produce the greatest electromotive force ; but from the expense of this latter element, and on account of its low conducting power and the difficulty of making good joints, antimony is generally substituted.

When rods, $AB, A'B'$, of two metals have their ends A, A' , joined together, the other ends B, B' , being connected by copper wires to the terminals of a galvanometer, and the junction AA' is heated to, and maintained at, a definite temperature, the deflection of the galvanometer needle will be constant, so long as the points B, B' , and the rest of the circuit are at the same temperature, which may be higher or lower than that of the junction AA' . Further, the electromotive force is the same whether A and A' are merely in contact, or are soldered together, or joined by any other metal, provided all parts of the junction are at the same temperature.

870. **Thermo-electric inversion.**—For small differences the E.M.F. of a thermo-electric pair is proportional to the difference of temperature of the junctions, but for greater ranges this rule no longer holds, even though the

mean temperature is kept constant. In some cases the E.M.F. increases more rapidly than the temperature-difference; in others the *rate of increase* with rising temperature of the hot junction diminishes, until at a certain temperature it becomes zero and changes sign. Let one junction of a copper-iron couple be kept at 0° while the other is gradually heated; the E.M.F. increases until the temperature reaches 276° , and then diminishes, becoming zero when the temperature is 552° . If one junction is as much above 276° as the other is below it, there will be no E.M.F., and no current, in the circuit. This temperature is called the *neutral temperature*. When the mean temperature of the circuit is the neutral temperature there will be no E.M.F., however great may be the difference of temperature between the hot and cold junctions. If the temperature in the above case is pushed beyond 552° , a negative E.M.F. is developed, increasing with temperature. This phenomenon is known as *thermo-electric inversion*, and is easily exhibited by twisting together the ends of copper and iron wires, and connecting the free ends to a low-resistance reflecting galvanometer. If the junction is gradually heated in a spirit flame, the spot of light will be seen to advance, first quickly, then more slowly, reach a limiting position, return, pass the zero, and proceed in the opposite direction.

871. **Causes of thermo-electric currents.**—Thermo-electric currents are probably to be attributed to an electromotive force produced by the contact of heterogeneous substances, a force which varies with the temperature. When all the parts of a circuit are homogeneous, no current is produced on heating, because the heat is equally propagated in all directions. This is the case if the terminals of the galvanometer are connected by a simple copper wire. But if we destroy the uniformity of this wire by coiling it in a spiral, or by knotting it (fig. 856), the needle indicates by its deflection a current going from the heated part to that in which the homogeneity has been destroyed by the twisting produced; this is not seen with platinum wire. If the ends of the galvanometer wires are coiled in a spiral, and one end is heated and touched with the other, the current goes from the heated to the cooled end.



Fig. 856

If one part of a piece of brass wire, whose ends are connected to a galvanometer, is annealed, and the junction between annealed and unannealed is heated, a current is produced flowing from unannealed to annealed through the hot junction.

Svanberg found that the thermo-electromotive force is influenced by the crystallisation; for instance, if the cleavage of bismuth is parallel to the face of contact, it is greater than if both are at right angles, and the reverse is the case with antimony. Thermo-electric couples may be constructed of either two pieces of bismuth or two pieces of antimony, if in the one the principal cleavage is parallel to the place of contact, and in the other is at right angles. Hence the position of metals in thermo-electric series is influenced by their crystalline structure.

872. **Thermo-electric battery.**—From what has been said it will be understood that a thermo-electric couple consists of two metals soldered together, the two ends of which can be joined by a conductor. Fig. 857 represents a bismuth-copper couple ; fig. 858 represents a series of couples used by Pouillet. The former consists of a bar of bismuth bent twice at right angles, at the ends of which are soldered two copper strips, *c*, *d*, which terminate in two binding screws fixed on some insulating material.

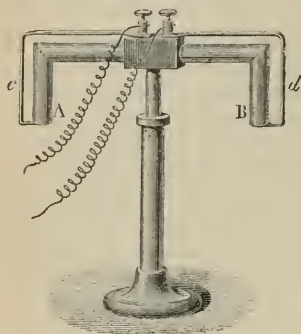

Fig. 857

When several of these couples are joined so that the second copper of the first is soldered to the bismuth of the second, then the second copper of this to the bismuth of the third, and so on, this arrangement constitutes a thermo-electric battery, which is worked by keeping the odd solderings, for instance, in ice, and the even ones in water heated to 100° .

The electromotive force of each couple under these conditions is about $\cdot 01$ volt.

873. **Nobili's thermo-electric pile.**—Nobili devised a form of thermo-electric battery, or *pile*, as it is usually termed, in which there are a large number of couples in a very small space. For this purpose he joined the couples of bismuth and antimony in such a manner that, after having formed

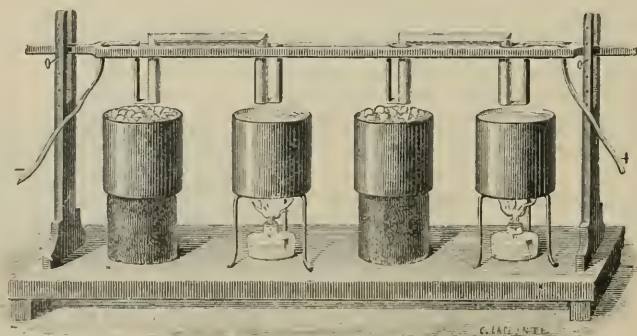

Fig. 858

a series of five couples, as represented in fig. 860, the bismuth from *b* was soldered to the antimony of a second series arranged similarly ; the last bismuth of this to the antimony of a third, and so on for four vertical series, containing together 20 couples, commencing by antimony, finishing by bismuth.

Thus arranged, the couples are insulated from one another by means of small paper bands covered with varnish, and are then enclosed in a copper frame, *P* (fig. 859), so that only the solderings appear at the two

ends of the pile. Two small copper binding screws, *m* and *n*, insulated in an ivory ring, communicate in the interior, one with the first antimony, representing the positive pole, and the other with the last bismuth, representing the negative pole. Covers, not shown in the figure, fit on the ends of the frame to protect the faces of the pile from accidental changes of temperature.

The E.M.F. of a single bismuth-antimony pair for 1° difference of temperature is about 122 micro-volts, and for a pile of 20 pairs, 2440 micro-volts. If the terminals were connected to a moderately sensitive galvanometer—of, say, 5 ohms resistance, and having a reduction factor of .5 micro-ampere per division (841)—the deflection would be 1000 divisions, so that a deflection of 1 division would correspond to a difference of temperature of $.001^{\circ}$ C. between opposite faces of the thermo-pile.

The most sensitive arrangement of this class is the *radiomicrometer* invented by Mr. Boys. It consists of a light thermo-junction suspended by a thin quartz thread (89) between the poles of a strong horseshoe magnet ;

it resembles in fact D'Arsonval's galvanometer (fig. 897). With the slightest difference in the temperature of the two ends of the bars of the thermo-pair a current is produced in its circuit, and this being in a magnetic field is deflected like any current under the influence of a field. And as the force tending to deflect it depends upon the product of the current into the strength of the field, it follows that with a strong field only an extremely feeble current is necessary to produce a considerable deflection. By its means Mr. Boys can detect differences of less than one-millionth of a degree Centigrade. It will clearly respond to a quantity of heat not greater than that which would be received on a halfpenny by the flame of a candle at a distance of 1530 feet.

874. **Clamond's thermo-electric battery.**—Of the attempts which have been made to apply thermo-electric currents to directly practical purposes, perhaps the most successful has been Clamond's, which has been used for telegraphic purposes and also for electroplating. Its characteristic features are the construction and arrangement of the elements, and the manner in which the heating is effected.

The negative element of the couple consists of an alloy of two parts of antimony and one of zinc, forming a flat spindle-shaped bar from 2 to 3 inches in length by $\frac{3}{8}$ inch in thickness (fig. 862). The positive metal is a thin strip or lug of tin-plate, stamped as represented at *a a'* in fig. 861 ; this is then bent in as shown at *c*, and being held in a mould, the alloy, which melts at 260° C., is poured in. The individual elements have then the appearance represented in fig. 862, and to connect them together the tin lugs are bent into shape, and joined in a circle of elements (fig. 863), being kept

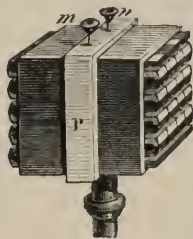

Fig. 859



Fig. 860



Fig. 861



Fig. 862

in their position by a paste of asbestos and soluble glass ; flat rings of this composition are also made, and are placed between each series of rings piled over each other ; the connection between the individual elements and between the sets of rings is made by soldering together the projecting ends of the tin lugs. Thin plates of mica are placed between the alloy and the tin-plate, excepting at the place of soldering. Looked at from the inside, the faces of the battery present the appearance of a perfect cylinder.

The heating is effected by means of coal gas, admitted through an earthenware tube, AB, fig. 864, perforated by numerous small holes : this is surrounded by a somewhat larger iron tube, CD, reaching nearly to the top of the cylinder, which is closed by a lid, EF. Air enters at the bottom of this tube, and the heated gases, passing up the tube, curl over the top, descend on the outside, and escape by a chimney, GH. This arrangement economises gas and prevents danger from overheating, as the gas-jets do

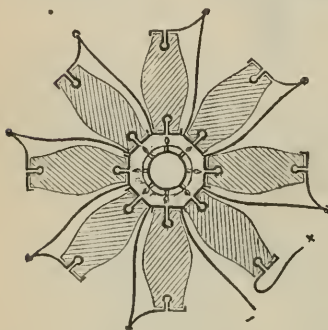

Fig. 863

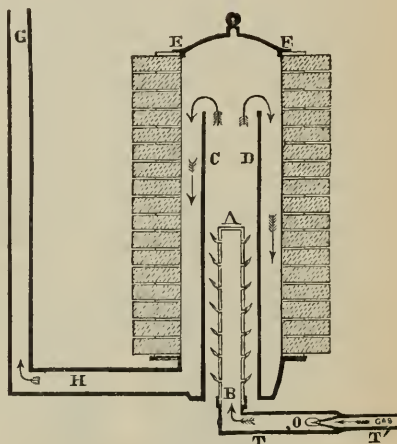

Fig. 864

not impinge directly on the metallic junctions. The supply of gas is regulated by an automatic arrangement, so that the temperature is not higher than about 200° .

Although sometimes convenient, thermo-electric batteries are by no means an economical source of electricity. Thus a Clamond's battery of 120 elements has an E.M.F. of 8 volts, and a resistance of 3.2 ohms ; its maximum available work can be shown to be 5 watts per second ; and the consumption of gas per hour is 180 litres. The heat of combustion of a litre of gas gives 5200 gramme calories ; the heat expended per second is, therefore, 260 calories, which would correspond to 1084 watts. The yield is therefore only about $\frac{1}{210}$ of the heat supplied.

Taking the ordinary price of gas in large towns, the cost of producing a horse-power by a thermo-electric battery would be nearly three shillings an hour for gas alone.

875. **Becquerel's electric pyrometer.**—This apparatus consists (fig. 865) of two wires, one of platinum and the other of palladium, each two metres in length and a sq. mm. in section. They are not soldered at the ends, but firmly tied for a distance of a centimetre with fine platinum wire. The palladium wire is enclosed in a thin porcelain tube; the platinum wire is on the outside, and the whole is enclosed in a larger porcelain tube, P. At the end of this is the junction, which is adjusted in the place the temperature of which is to be investigated. At the other end project the platinum and palladium wires *m* and *n*, which are soldered to two copper wires that lead the current to a

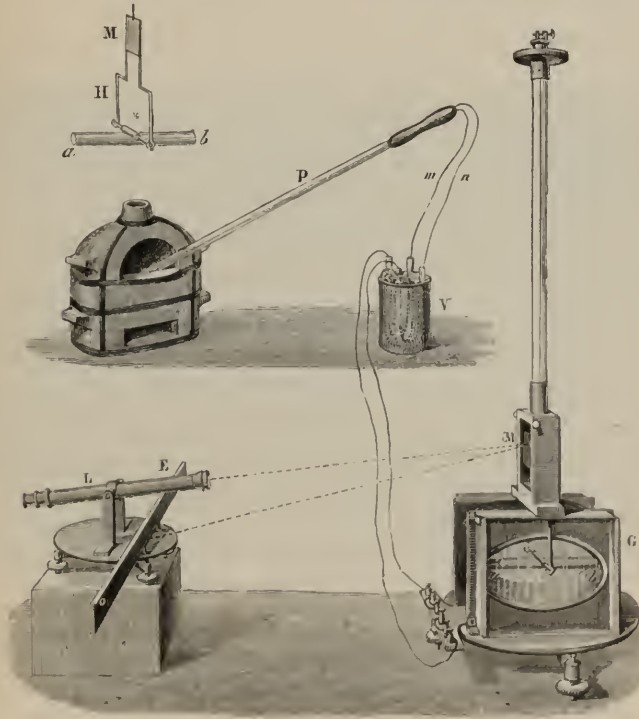

Fig. 865

galvanometer, G. These wires at the junction are placed in a glass tube immersed in ice, so that, being both at the same temperature, they give rise to no thermo-electromotive force.

The galvanometer, which was devised by Weber, consists of a magnetised bar, *ab*, placed within a copper frame, which damps the oscillations (963) and rests on a stirrup, H, which in turn is suspended from a long and very fine platinum wire. On the stirrup is fixed a mirror, M, which moves with the magnet, and gives by reflection the image of divisions traced on a horizontal scale, E, at a distance. These divisions are observed by a telescope. With

this view, before the current passes the image of the zero of the scale is made to coincide with the micrometer wire of the telescope ; then the slightest deflection of the mirror gives the image of another division, and therefore the angular deflection of the bar magnet. This angle is always small, and should not exceed 3 or 4 degrees : a result which is secured by placing, if necessary, a rheostat or a resistance coil in the circuit. The angular deflection being known, the intensity of the current and the temperature of the junction are deduced from pyrometric tables. These are constructed by interpolation when the strengths are known which correspond to two temperatures near those to be observed. The indications of the pyrometer extend to the fusing point of palladium.

Lechatellier has greatly improved this method by using a couple of platinum associated with an alloy of platinum with 10 per cent. of rhodium, both in the form of wires. These are connected with a D'Arsonval's dead-beat galvanometer (897). The couple is placed in various metals and salts at their melting points, the temperatures of which are known, and from the observed deflections a scale is empirically graduated. In this way temperatures up to 1200°C . may be determined which are accurate to within less than 10° .

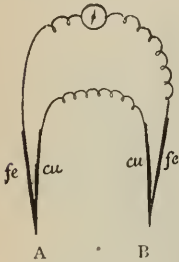

Fig. 866

The principle of the arrangement known as Becquerel's *thermo-electric needle* is adapted for temperatures below the boiling point of water. Two identical couples are joined in series in opposition to each other. The junction A being placed at the point whose temperature is to be determined, the junction B is placed in a bath, the temperature of which can be varied until there is no deflection of the galvanometer. The temperature of the two junctions is then the

same. The same principle is made use of for determining the rise of temperature in the field magnet coils of a dynamo, one of the junctions being embedded amongst the field coils.

876. Properties and uses of thermo-electric currents.—Thermo-electric currents are of extremely low potential, but of great constancy ; for the opposite junctions of thermo-electric couples can easily be kept at 0° and 100°C . by means of melting ice and boiling water. On this account, Ohm used them in the experimental establishment of his law. They can produce all the actions of the ordinary battery in kind, though in less degree. By means of a thermo-electric pile consisting of 769 elements of iron and german silver, the ends of which differed in temperature by about 10° to 15° , Kohlrausch proved the presence of free positive and negative electricity at the two ends of the open pile respectively. He found that the E.M.F. was nearly proportional to the number of elements, and also that the electromotive force of a single couple in the above circumstances was about $\cdot 0015$ that of a single Daniell's cell. On account of their low potential, thermo-electric piles produce only feeble chemical actions. Botto, however, with 120 platinum and iron wires, decomposed water.

877. Thermo-electric diagram.—Thermo-electric relations may be very conveniently illustrated by means of what is called the *thermo-electric*

diagram. In fig. 867 the abscissæ represent the temperatures of the junctions on the Centigrade scale, and ordinates represent thermo-electric powers in terms of micro-volts per degree Centigrade. Lead, for a reason to be presently explained (879), is taken as the metal of reference. The different metals are represented by straight lines and the significance of the diagram may be illustrated by taking an example. At 50° the ordinate of the iron curve is -13 , which means that if we make a circuit of the two metals iron and lead, and if one junction is at $49\frac{1}{2}^\circ$ and the other at $50\frac{1}{2}^\circ$, so that the temperature difference is 1° and the mean temperature 50° , the E.M.F. in the circuit will be 13 micro-volts, and the current will flow from lead to iron through the warmer junction. If, instead of iron, we take copper at the same temperature, the E.M.F. is 1 micro-volt; and if the metals employed are iron and copper,

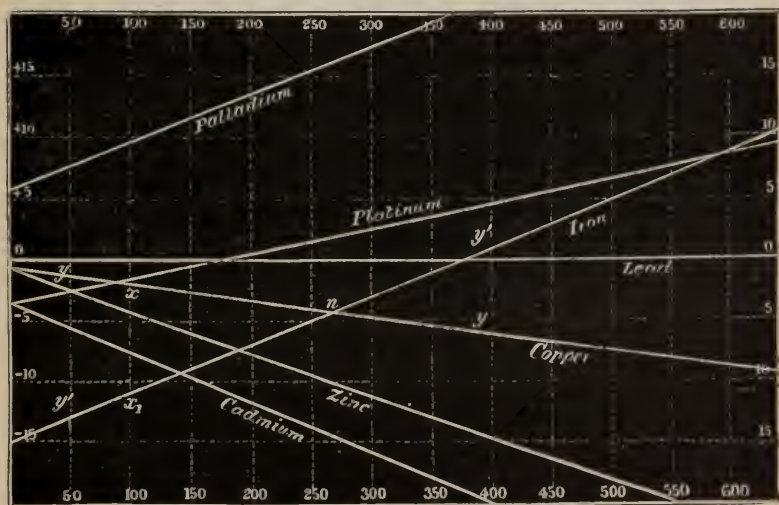

Fig. 867

the diagram tells us that at 50° the E.M.F. per degree is $yy' = 13 - 1 = 12$ micro-volts, that is, it is the area of a narrow strip 1° wide and yy' in length. If one junction is at 0 and the other at 100° the mean temperature is still 50° , and the E.M.F. = $12 \times 100 =$ the area $o, x, x_1, -15$; this area increases, but at a diminishing rate, as the temperature of the hot junction is raised above 100° , the other junction being still kept at 0, and reaches its maximum value when it is equal to the triangle $o, n, -15$. The neutral temperature (276° C.) has now been attained, and on further heating, say to 400° , it will be necessary to subtract the area n, y, y' from the triangle $o, n, -15$, in order to get the area representing the electromotive force. It is clear that if the temperature is raised to 552° (= twice 276°) the E.M.F. vanishes, and beyond this temperature is reversed in sign.

878. **Peltier's experiment.**—When on a bar of bismuth, BB, cut halfway through at its centre (fig. 868), is soldered a bar of antimony with a similar

cut, and when the ends A and B are connected with a galvanometer, the needle of the galvanometer is deflected in one direction when the junction is heated, and in the other when it is cooled.

Peltier found by means of this apparatus, which is known as *Peltier's cross*, that when the end A' was connected with one pole, and B' with the other pole of a voltaic cell, so that a current passed from A' through the junction to B', the needle was deflected in such a direction as to show that the junction was heated when the cell current passed from A' to B', while it was cooled when the current passed in the opposite direction. This is called the *Peltier effect*. In order to show the cooling effect, this experiment may be made by hermetically fixing, in two tubulures in an air

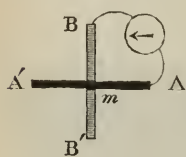

Fig. 868

thermometer, a compound bar consisting of bismuth and antimony soldered together in such a manner that the ends project on each side. The projecting parts are provided with binding screws, so as to allow a current to be passed through. When the current passes from the antimony to the bismuth, the air in the bulb is heated, it expands, and the liquid in the stem sinks; but if it passes in the opposite direction the air is cooled, it contracts, and the liquid rises in the stem. The current must not be too strong, otherwise the liquid in the stem will sink, whichever way the current flows, in consequence of the heating of the metal rods themselves (860).

By making a small hole at the junction of a bismuth and antimony bar, in which were placed a drop of water and a small thermometer, the whole being cooled to zero, Lenz found that when a current was passed from bismuth to antimony the water was frozen and the thermometer sank to -3.5°C .

The Peltier experiment may also be illustrated by interposing an iron wire between two copper wires, and surrounding one junction with water at 0° , and the other with ice at 0° . On passing a feeble current, it is found that as much ice melts at one junction as is produced at the other.

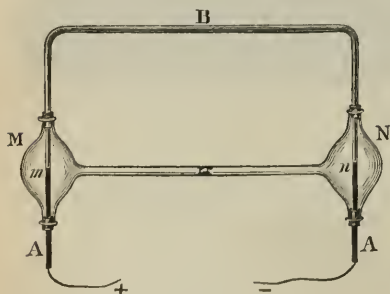

Fig. 869

The Peltier effect is independent of the heating effect which is produced when a current traverses any conductor, and which may be called the *frictional heating* or *Joule effect*. The heat due to this cause is proportional to the square of the current, C , to the resistance, R , and to the time, t , and is independent of the direction of the current (860); while the Peltier effect is proportional to the strength of the current and to the time, and is reversible with its direction. This suggests a method of determining the effect in question. It is equal to $\mathfrak{P}Ct$, where \mathfrak{P} is a constant which is called the *coefficient of the Peltier effect*. The frictional heat is equal to C^2Rt . Hence, if the current is passed so that in one case the Peltier effect coincides with the Joule effect, while in the other it is opposed to that effect, we shall have for the total heat H and H' in the

two cases : measured in dynamical units $H = C^2Rt + \phi Ct$, and $H' = C^2Rt - \phi Ct$, from which

$$\phi = \frac{H - H'}{2Ct}.$$

That the Peltier effect is independent of the Joule heating has been established by Edlund, by a method the principle of which is represented in fig. 869. *M* and *N* are two bulbs, and are connected by a narrow glass tube, in which is a drop of liquid serving as index. The rods of metal *A* and *B* are fixed airtight in the bulbs, and are soldered at *m* and *n*, while the free ends can be connected with a battery. If the pieces *m* and *n* inside the glass vessels offer the same resistance, and these vessels are of the same size, when the current passes the Joule effect is the same in each case, and consequently the index is equally pressed in opposite directions, and therefore does not move. But the Peltier effect is opposite in the two vessels, and produces a displacement of the index, from which the change of temperature can be deduced.

The Peltier effect, as will be seen, is greater as the term $2Ct$, or the strength of the current, is less, and hence it can only be shown with feeble currents.

These experiments form an interesting illustration of the principle, that whenever the effects of heat are reversed heat is produced ; and whenever the effects ordinarily produced by heat are otherwise produced, cold is the result ; for cooling takes place when the current is in the same direction as the thermo-current which would be produced by heating the junctions and heating when the current is in the opposite direction.

879. **Thomson effect.**—If we take two bars of the same metal *AB* and *A'B'*, which are connected at the ends *B B'* by a wire, so that a current can be passed through them, then the temperature of each part of the bars due to the Joule effect would be the same when the stationary condition is attained. If the two ends *B B'* are kept at a constant temperature of 100° by being immersed in boiling water, while the others *A A'* are placed in melting ice, and are thus at 0° , and if now a thermopile is placed

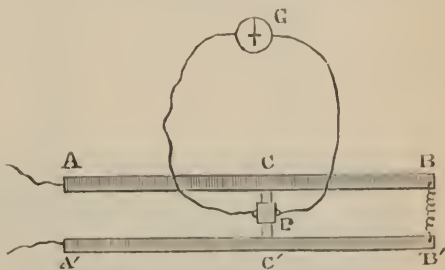

Fig. 870

with its two opposite faces in contact with symmetrical portions of the two bars, it will be found that when a current passes through the system at *AB B' A'*, the galvanometer of the thermopile is deflected, showing that there is a difference of temperature at the two ends of the pile—that is, the corresponding parts of the bars are not at the same temperature. In the case of copper, silver, zinc, and antimony the point would be hotter on that bar along which the current passes from hot to cold ; in the case of tin, aluminium, platinum, bismuth, and iron it is hotter when the current passes from cold to hot.

This phenomenon, which is known as the *Thomson effect* from its discoverer, Lord Kelvin, is most marked in antimony among positive metals and in iron; it is a sort of *electric convection of heat*; in copper the current carries heat along with it. In iron heat apparently travels against the current. Cold copper behaves towards hot copper in the same way as bismuth behaves towards antimony, so that when a current is passed from the hot to the cold end of a bar of copper there is an evolution of heat at all points along the bar. In a bar of iron under similar conditions there is an absorption of heat.

In the case of those metals whose lines slope downwards in the thermo-electric diagram (fig. 867), such as copper, zinc, &c., heat travels with the electricity when the current passes from the hotter to the colder portion of an unequally heated bar. In the case of those metals whose curves slope upwards, iron, platinum, &c., heat travels in the opposite direction. Le Roux found that lead has no Thomson effect—that is, there is no motion of heat either with or against the current. This is why lead is chosen as the standard in the thermo-electric diagram.

Le Roux also showed that the Thomson effect is proportional to the strength of the current.

CHAPTER VI

ELECTRODYNAMICS

880. **Electrodynamics.**—By the term *electrodynamics* is understood the laws of electricity in a state of motion, or the action of electric currents upon each other and upon magnets, while *electrostatics* deals with the laws of electricity in a state of rest.

The action of one electric current upon another was first investigated by Ampère, shortly after the discovery of Oersted's celebrated fundamental

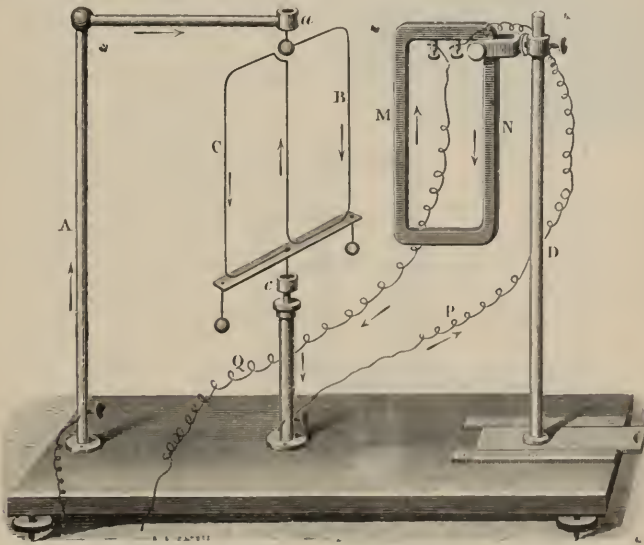

Fig. 871

experiment (835). All the phenomena, even the most complicated, follow from two simple laws, which are—

I. *Two currents which are parallel, and in the same direction, attract one another.*

II. *Two currents parallel, but in contrary directions, repel one another.*

In order to demonstrate these laws, the circuit which the current traverses must consist of two parts, one fixed and the other movable. This is effected

by the apparatus (fig. 871), which is a modified and improved form of one originally devised by Ampère.

It consists of two brass columns, A and D, between which is a shorter one. The column D is provided with a rectangular frame, MN, on which is wound a number of turns of insulated wire (fig. 873), the sensitiveness of the instrument increasing with the number of turns. This frame can be adjusted at any height, and in any position, by means of a universal screw clamp (see figs. 873-876).

The short column is hollow, and in its interior slides a brass tube terminating in a mercury cup, c , which can be raised or lowered. On the column A is another mercury cup, represented in section at fig. 872 in its natural size. In the bottom is a capillary aperture through which passes the point of a sewing needle fixed to a small copper ball. This point extends as far as the mercury, and turns freely in the hole. The movable part of the circuit consists of a copper wire proceeding from a small ball, and turning in the direction of the arrows

from the cup a to the cup c . The two lower branches are fixed to a thin strip of wood, and the whole system is balanced by two copper balls, suspended to the ends.

These details being known, the current from a battery of 6 or 8 volts ascending by the column A (fig. 873) to the cup a , traverses the circuit BC, reaches the cup, c , descends the central column, and thence passes by a wire, P, to the coil MN, whence it returns to the battery by the wire Q. Now, if, before the current passes, the movable circuit has been arranged in the plane of the coil, with the sides B and M opposite each other, when the current passes, the side B is repelled, which demonstrates

the second law; for in the branches B and M the currents, as indicated by the arrows, are proceeding in opposite directions.

To demonstrate the first law the experiment is arranged as in fig. 873—that is, the multiplier is reversed; the current is then in the same direction both in the multiplier and in the movable part; and when the latter is removed out of the plane of the multiplier, so long as the current passes it tends to return to it, proving that there is attraction between the two parts.

881. **Roget's vibrating spiral.**—The attraction of parallel currents may also be shown by an experiment known as that of *Roget's vibrating spiral*

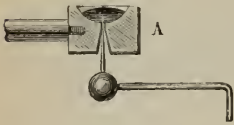

Fig. 872

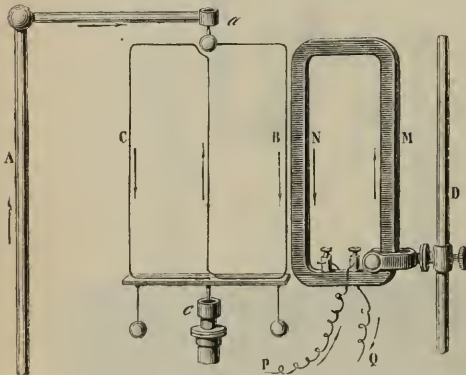

Fig. 873

(fig. 874). A copper wire about 0.7 mm. in diameter is coiled in a spiral of about 30 coils of 25 mm. in diameter. At one end it is hung vertically from a binding screw, while the other just dips in a mercury cup. On passing a current of 2 or 3 amperes through the spiral by means of the mercury cup and the binding screw, its coils are traversed by parallel currents; they therefore attract one another, and rise, and thus the contact with the mercury is broken, and a small spark occurs. The current having thus ceased, the coils no longer attract each other, they fall by their own weight, contact with the mercury is re-established, and the series of phenomena is indefinitely reproduced. The experiment is still more striking if an iron rod the thickness of a pencil is introduced into the interior, as shown in the figure. The self-induction (967) of the circuit being increased, the sparks are much more vivid and noisy.

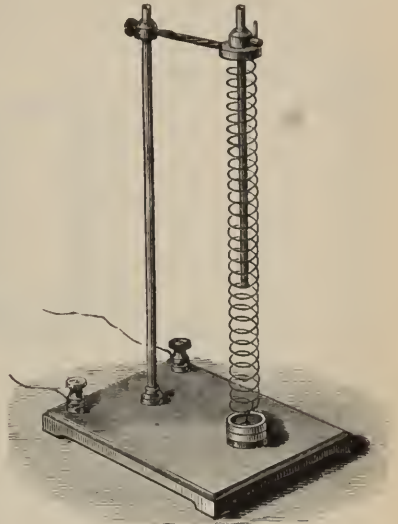

Fig. 874

882. Laws of angular currents.

I. *Two rectilinear currents, the directions of which form an angle with each other, attract one another when both approach or recede from the apex of the angle.*

II. *They repel one another if one approaches and the other recedes from the apex of the angle.*

These two laws may be demonstrated by means of the apparatus above described, the movable circuit being replaced by the circuit BC (fig. 875). If then the rectangular frame is placed horizontally, so that its current is in the same direction as in the movable current, on removing the latter it quickly approaches the fixed coil, which verifies the first law.

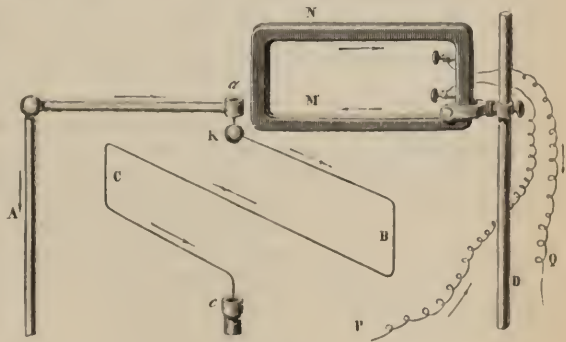

Fig. 875

To prove the second law, the coil is turned so that the currents are in opposite directions, and then repulsion ensues (fig. 875).

Both laws are included in the statement that the two circuits tend to become parallel to each other with their currents in the same direction.

883. **Laws of sinuous currents.**—*The action of a sinuous current is equal to that of a rectilinear current of the same length in projection.*

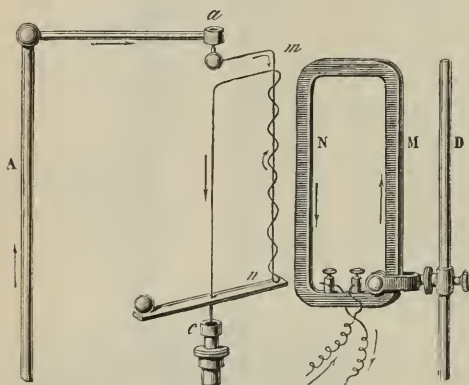

Fig. 876

This principle is demonstrated by arranging the fixed coil vertically and placing near it a movable circuit of insulated wire half sinuous and half rectilinear (fig. 876). It will be seen that there is neither attraction nor repulsion, showing that the action of the sinuous portion *mm* is equalled by that of the rectilinear portion.

An application of this principle will presently be met with in the apparatus called *solenoids* (893),

which are formed of the combination of a sinuous with a rectilinear current.

884. **Action of an infinite rectilinear current on a rectangular or circular current.**—It is easy to see that a horizontal infinite current exercises the same directive action on a rectangular current movable about a vertical axis (fig. 877) as that which has been above stated. For from the direction of the currents indicated by the arrows, the part *QY* acts by attraction not only on the horizontal portion *YD* (*law of angular currents*), but also on the vertical portion *AD*. This latter statement will be evident if we suppose a line to be drawn perpendicular both to *YQ* and to *AD*; it will be the shortest line between their directions. The part of the current *QY* which is on the right of this line will attract *AD*, for both currents are moving in the same direction, and the part on the left will repel *AD*, for one is moving towards, and the other from, the shortest line between them. Hence, from both causes, *AD* will move to the right. The same action evidently takes place between the part *PY* and the parts *CY* and *BC*. Hence, *the fixed current PQ tends to direct the movable rectangular current ABCD into a position parallel to PQ, and such that in the wires CD and PQ the direction of the two currents is the same.*

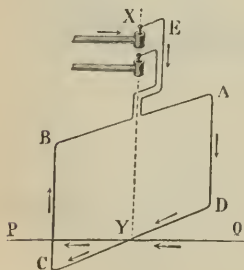

Fig. 877

This principle is readily demonstrated by placing the circuit *ABCD* on the apparatus with two supports (fig. 877), so that at first it makes an angle with the plane of the supports. On passing a somewhat powerful current below the circuit in the same plane as the supports, the movable part

passes into that plane. It is best to use the circuit in fig. 873, which is astatic, while that of fig. 877 is not.

What has been said about the rectangular current in fig. 877 applies also to circular currents, and is demonstrated by the same experiments.

885. **Motion of currents in a magnetic field.**—The phenomena of the attraction and repulsion of currents described in the preceding articles may also be explained by reference to the magnetic fields produced by the currents. A current through a straight wire is accompanied by a magnetic field, the lines of force in which are circles in planes at right angles to the wire, with their centres in the wire (834). A north magnetic pole placed in such a field tends to move round the current along a line of force and the direction of motion is given by Ampère's rule, which states that if we imagine a swimmer in the wire swimming in the direction of the current, and looking at the north pole, the pole will move towards his left hand. In this case the current is supposed to be fixed, and the pole movable, but the action between the two is reciprocal—that is, if the pole is fixed, and the wire carrying the current capable of motion in a direction at right angles to itself, it will move to the right hand of the swimmer. And generally a movable straight conductor carrying a current in a magnetic field, and capable of moving at right angles to its own length, will move towards the right hand of the hypothetical swimmer who, swimming with the current, places himself so that the lines of force in the field pass through him from front to back. Applying this rule to the cases represented in figs. 871, 873, where the lines of force due to the current in M or N are closed curves threading through the frame MN and the swimmer is in the movable conductor B, apparent *repulsion* of B in fig. 871 and *attraction* in fig. 873 must occur. The motion of the rectangular coil, ABCD, in fig. 877, follows the same rule, for the circular lines of force due to the current QP are coming up towards the swimmer in YC, and his right hand is therefore directed towards the direction of P and away from Q, whatever be the position of the rectangle. The rectangle will be at rest, and in a position of minimum potential energy with regard to the current QP, when it is parallel to the latter, and in these circumstances more lines of force due to QP pass through it than when the rectangle has any other position. Moreover, its own lines of force due to the current flowing through it (835) are in the same direction as those proceeding from QP, so that in its position of rest it has the maximum number of lines of force passing through it. This is in conformity with a principle of universal application, which may be stated thus :—When a circuit in a magnetic field is traversed by a current, it will alter its position and configuration so as to enclose the greatest possible number of lines of force.

The principle is illustrated in the following experiment :—If the ends of two copper wires connected to the terminals of a battery are joined by a loop of a flexible conductor, such as the thin tinsel used in embroidery, the loop will probably hang down in such a way as to enclose a very small area ; but, if a current passes through the circuit, the loop swells out so as to present a larger area and to increase the number of lines of force through it. If the material were perfectly flexible, it would take a circular form. In order to use a fairly strong current in this experiment, and at the same time

to avoid the risk of fusion, it is better to immerse the fine wire in water, which will carry off the heat by convection as fast as it is produced, and is practically a non-conductor of electricity.

886. **Rotation of a vertical current by a horizontal circular current.**—A horizontal circular current, acting on a rectilinear vertical, also imparts to it a continuous rotatory motion. In order to show this, the apparatus represented in fig. 878 is used.

It consists of a brass vessel, round which are coiled several turns of insulated copper wire, through which a current passes. In the centre of the vessel is a brass support, *a*, terminated by a small cup containing mercury. In this dips a pivot supporting a copper wire, *b, b*, bent at its ends in two vertical branches, which are soldered to a very light copper ring immersed in acidulated water contained in the vessel. A current entering through the wire *m* passes through the coil A, and terminates at B, which is connected by a wire underneath with the lower part of the column *a*. Ascending in this column, it passes by the wires *b, b* into the copper ring, and through

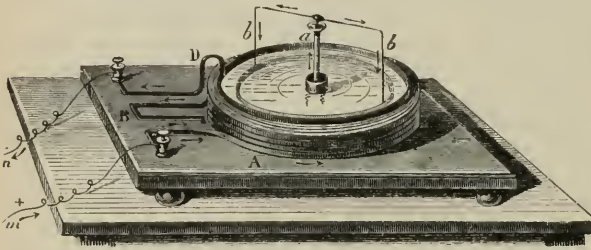

Fig. 878

the acidulated water to the sides of the vessel, whence it returns to the battery by the strip *D*. The circuit being thus closed, the wire *bb* and the ring tend to turn in a

direction contrary to that of the fixed current. This may be explained by reference to the various attractions and repulsions between the circular currents and those in the wire; but the result follows at once from the consideration that the current in the coil *A* produces a magnetic field, the lines of force in which come upwards through the coil. In the neighbourhood of the centre they are nearly straight, and towards the circumference they curl over and enter the coil underneath. If Ampère's swimmer is placed anywhere on the wire *bb* and faces the lines, his right hand will indicate the direction of motion, which will be against that of the current in *A*.

887. **Rotation of magnets by currents.**—Faraday proved that currents impart the same rotatory motions to magnets that they do to currents. This may be shown by means of the apparatus represented in fig. 879. It consists of a large glass vessel, almost filled with mercury. In the centre of it is immersed a magnet, *A*, about eight inches in length, which projects a little above the surface of the mercury, and is loaded at the bottom with a platinum cylinder. At the top of the magnet is a small cavity containing mercury; the current ascending the column *m* passes into this cavity by the rod *C*. From the magnet it passes by the mercury to a copper ring, *G*, when it emerges by the column *n*. When the current flows the magnet begins to rotate round its own axis with a velocity depending on its magnetic power and on the strength of the current.

Instead of making the magnet rotate on its axis, it may be caused to rotate round a line parallel to its axis by arranging the experiment as shown (fig. 880).

This rotatory motion is readily intelligible on Ampère's theory of magnetism (894), according to which, a magnet is traversed on its surface by an infinity of circular currents in the same direction, in planes perpendicular to the axis of the magnet. At the moment at which the current

passes from the magnet into the mercury, it divides on the surface of the mercury into an infinity of rectilinear currents proceeding from the axis of the magnet to the circumference of the glass. Figs. 881 and 882, which correspond respectively to figs. 879 and 880,

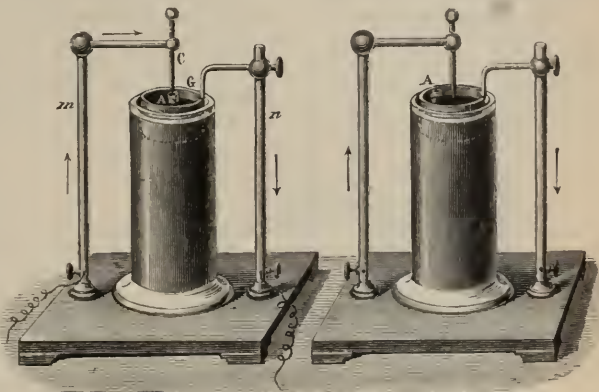

Fig. 879

Fig. 880

give on a larger scale, and on a horizontal plane passing through the surface of the mercury, the direction of the currents to which the rotation is due. In fig. 879, the north pole being at the top, the Amperian currents (894) pass round the magnet in the reverse direction to that of the hands of a watch, as indicated by the arrow *i* (fig. 881), while the currents which radiate from the rod C towards the metal ring GG' have the direction CD, CE, &c. Thus (881) any given element *e* of the magnetic current of the bar A is attracted by the current CE and repelled by the current CD; hence results a rotation of the bar about its axis in the same direction as the hands of a watch.

In fig. 882 the currents CD, CF, being in the opposite direction to those of the bar, would repel the latter, which would be attracted by the currents CE, CH. Hence the bar rotates in a circular direction, shown by the arrow *s*, about the vertical axis which passes through the rod C.

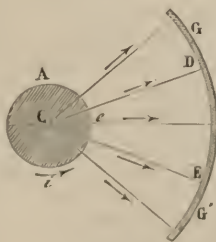

Fig. 881

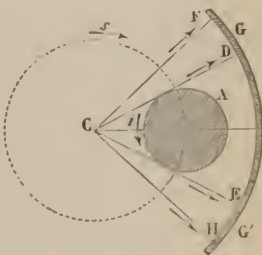

Fig. 882

If the north pole is below, or if the direction of the current is altered, the rotation of the magnet is in the opposite direction.

These motions may also be explained by applying Ampère's rule to the lines of force due to the magnet. In fig. 881 the current enters the magnet at C, the middle of its north end. Lines of force emerge from all parts of the end, so that a swimmer in the current which enters at C will be looking at a north pole in whatever direction he faces, and the point to which he looks must move towards his left hand. Hence the magnet rotates in the direction stated. The reader will have no difficulty in explaining in a similar way the motion of the magnet in the second case (fig. 882).

888. **Directive actions of magnets on currents.**—Not only do currents act upon magnets, but magnets also act upon currents. In Oersted's fundamental experiment (fig. 871), the magnet being movable while the current is fixed, the former is directed and tends to set at right angles to the current. If, on the contrary, the magnet is fixed and the current movable, the latter is

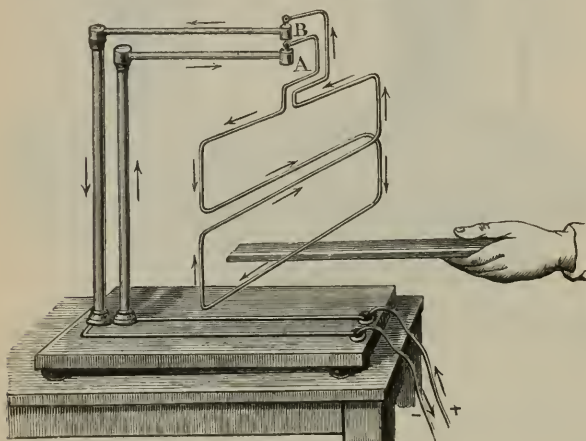

Fig. 883



Fig. 884

directed and sets across the direction of the magnet. This may be illustrated by the apparatus represented in fig. 883. This is the original form of *Ampère's stand*, and is frequently used in experimental demonstration. It needs no explanation. The circuit which the current traverses is movable, and below its lower branch a powerful bar magnet is placed; the circuit immediately begins to turn, and stops after some oscillations in a plane perpendicular to the axis of the magnet.

It is then in a position in which the lower rectangle contains as many as possible of the lines due to the magnet. The current in the upper rectangle of the movable frame is opposite to that in the lower, and thus diminishes the action between the magnet and the lower circuit, but, owing to its greater distance, does so to a comparatively small extent.

For demonstrating the action of magnets upon currents, De la Rive's *floating battery* (fig. 884) is well adapted. It consists of plates of zinc and copper which are immersed in dilute sulphuric acid contained in a glass bulb slightly loaded with mercury to keep it upright, and which can float freely on water. With the plates can be connected either circular or

rectangular wires, coils, or solenoids; they are then traversed by a current, and can be subjected to the action either of magnets or of currents.

889. **Rotation of currents by magnets.**—Not merely can currents be directed by magnets, but they may also be made to rotate, as is seen from the following experiment, devised by Faraday (fig. 885). On a base with levelling screws, and resting on an ivory support, is a copper rod, BD. It is surrounded in part of its length by a bundle of magnetised wires, AB, and at the top of it is a mercury cup. A copper frame, EF, balanced on a steel point, rests in the cup, and the other ends of the circuit, which terminate in steel points, dip in an annular trough full of mercury.

The apparatus being thus arranged, a current of 2 or 3 amperes enters at the binding screw *b*; it thence rises in the rod D, descends by the two branches, reaches the mercury by the steel points, whence it passes by the framework, which is of copper, to the battery by the binding screw *a*. If now the magnetised bundle is raised, the circuit EF rotates in a direction depending on the polarity of A. There is a mechanical force acting on the wire E or F, the direction of which is given by Ampère's rule. It is proportional to the current and to the pole strength of the magnet.

In this experiment the magnetised bundle may be replaced by a solenoid (893) or by an electromagnet, in which case the two binding screws in the base of the apparatus on the left give entrance to the current which is to traverse the solenoid or electromagnet.

The motion of a movable current in a magnetic field is also illustrated by *Barlow's wheel*, represented in fig. 886. It consists of a light-toothed metal wheel which can rotate about a horizontal axis, and is so arranged that one or more teeth dip in a mercury trough. The two branches of a horseshoe magnet are on opposite sides of the trough, and when the poles of a battery are connected with the axis and mercury respectively, the wheel at once rotates. If the current flows from the centre to the circumference of the wheel, and the north pole is in front, the wheel rotates in a direction opposite that of the hands of a watch.

Faraday's disc (fig. 887) is similar; the current arrives and departs by two springs, one B which presses against the axis, and the other A against the circumference of the wheel. H represents the direction of the lines of force of the field.

Let H, which represents the direction of the lines of force, denote also the strength of the field. Then the magnetic flux passing through the disc

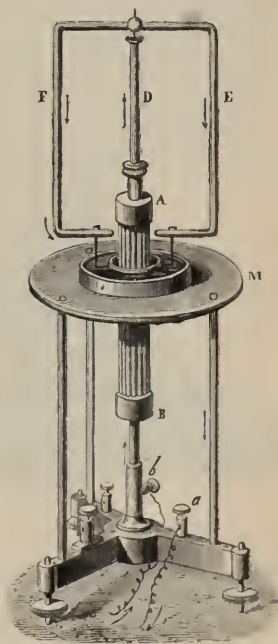

Fig. 885

is $\pi r^2 H$, r being the radius; and if C is the current, the torque or moment of the couple tending to make the disc rotate is $\pi r^2 H C$. The direction of motion is given by Ampère's rule.

890. **Electrodynamic and electromagnetic rotation of liquids.**—The condition of a linear current assumed in the previous experiments is not necessary. This may be illustrated by a simple form of experiment devised by Clerk Maxwell. At the bottom of a small beaker, a copper disc is placed with an insulated tongue bent at right angles, and connected with a similar zinc disc supported about an inch above the copper. Dilute acid is placed so as to cover both discs, and some fine sawdust having been added to the liquid, the whole is placed on the pole of an electromagnet. The rotation of the liquid is then shown by that of the sawdust.

891. **Directive action of the earth on vertical currents.**—The earth, which exercises a directive action on magnets (726), acts also upon currents,

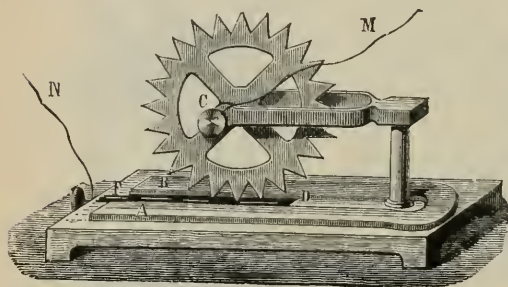

Fig. 886



Fig. 887

giving them in some cases a fixed direction, in others a continuous rotatory motion.

The first of these two actions may be thus enunciated: *Every vertical current movable about an axis parallel to itself places itself under the directive action of the earth in a plane through this axis perpendicular to the magnetic meridian, and stops after some oscillations, on the east of its axis of rotation when it is descending, and on the west when it is ascending.*

This may be demonstrated by means of the apparatus represented in fig. 889, which consists of two brass vessels of somewhat different diameters. The larger, a , about 13 inches in diameter, has an aperture in the centre, through which passes a brass support, b , insulated from the vessel, a , but communicating with the vessel K . This column terminates in a small cup, in which a light wooden rod rests on a pivot. At one end of this rod a fine wire is coiled, each end of which dips in acidulated water, with which the two vessels are respectively filled.

The current arriving by the wire m passes to a strip of copper, which is connected underneath the base of the apparatus with the bottom of the column b . Ascending in this column, the current reaches the vessel K and the acidulated water which it contains; it ascends from thence in the wire c , redescends by the wire e , and, traversing the acidulated water, it

reaches the sides of the vessel *a*, and so back to the battery through the wire *n*.

The circuit being thus closed, the wire *e* moves round the column *b*, and stops to the east of it, when it descends, as is the case in the figure. This result follows from the principles explained in art. 885. The horizontal component of the earth's magnetic field only is concerned, and the movable circuit *bce* places itself so as to add its own lines of force to those of the earth. It tends therefore to remain in an east and west plane, with the current as you look at it from the south going round in the same direction as the hands of a watch, that is with the wire *e* on the east side. If the direction of the current be reversed *e* will rest on the west side.



Fig. 883

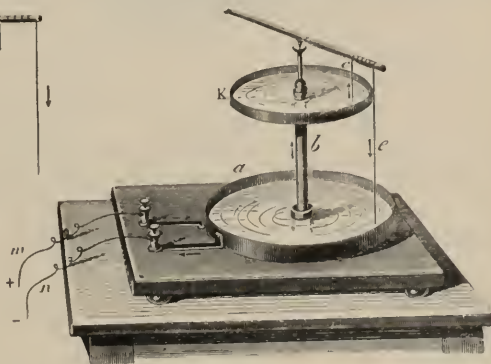

Fig. 889

If the rod with a single wire, in fig. 889, is replaced by one with two wires as in fig. 888, the rod will not move, for as each wire tends to place itself on the east of the column *a*, two equal and contrary effects are produced which counterbalance one another.

892. Action of the earth on currents movable about a vertical axis.—The action of the earth on horizontal currents is not directive, but gives them a continuous rotatory motion.

This may be illustrated by means of the apparatus represented in fig. 890, which only differs from that of fig. 889 in having but one vessel containing acidulated water. The current, ascending by the column *a*, traverses the two wires *cc*, and descends by the wires *bb*, from which it regains the battery; the circuit *bccb* then begins a continuous rotation anti-clockwise or clockwise, according as in the wires *cc* the current goes from the centre, as is the case in the figure, or goes towards it,

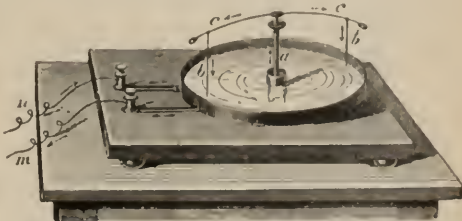

Fig. 890

which is the case when the current enters by the wire m , instead of by n . In this case we have to consider the vertical component of the earth's field; for the two circuits branching from a round to the acid on each side neutralise each other so far as the horizontal component is concerned (891). To face the vertical lines the swimmer in c must look upwards, and since he moves to his right the rotation is anti-clockwise.

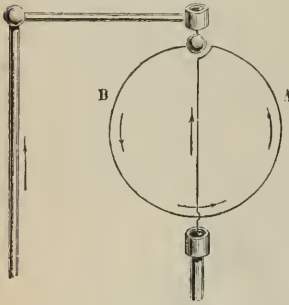

Fig. 891

When a circle of wire such as is shown in fig. 891 is supported so as to be movable about a vertical axis and a current passed through it, the circuit places itself in a plane perpendicular to the magnetic meridian with the current descending on the east side, for in this position the magnetic flux through the circuit is greater than in any other.

From the directive action which the earth exerts on circuits it is necessary, in many experiments, to neutralise this action. This is effected by arranging the movable circuit symmetrically about its axis of rotation, so that the directive action of the earth tends to

turn the two branches in opposite directions. This condition is fulfilled in the circuit in fig. 885. Such circuits are hence called *astatic circuits*.

893. **Solenoid.**—A *solenoid* is a system of equal and parallel circular currents formed of the same piece of covered copper wire and coiled in the form of a helix or spiral, as represented in fig. 892. A solenoid, however, is only complete when part of the wire BC passes in the direction of the axis in the interior of the helix. With this arrangement, when the circuit is traversed by a current it follows



Fig. 892

from what has been said about sinuous currents (883) that the action of a solenoid in a longitudinal direction, AB, is counter-balanced by that of the rectilinear current BC. This action is accordingly null in the direction of the length—that is, there is no

magnetic field in a plane perpendicular to the magnetic axis, all the lines of force lying in planes containing the axis.

The system of lines of force due to a circular current are shown in fig. 824. When a current flows through a number of parallel rings forming a solenoid (fig. 893), the direction of the current being the same in each ring, the lines of force due to the successive circles unite to form a system which traverses the interior of the solenoid from end to end, emerge at A, and, curving round in all directions, re-enter the solenoid at B. Thus the solenoid is associated with a system of lines of force precisely like that already described in the case of a bar magnet, and which is delineated in fig. 679. The solenoid shown in fig. 893 is constructed so that it can be suspended on two pivots in the cups a and c , and be freely movable about a vertical axis. When the circuit is complete the solenoid begins to move, and finally sets with its axis in the magnetic meridian and the end A towards the north. When deflected from this position it returns to it after some oscillations. The solenoid, in fact, behaves exactly like a magnet

with a north pole at A, where the lines of force emerge. It is to be observed that in the position of equilibrium the current is descending on the east side of the coil—that is, as we look at the end A, which corresponds to the north pole of a magnetic needle, we see that the current is going round in a direction opposite to that of the hands of a watch. Further, it may be noted that the position of equilibrium of the solenoid is in agreement with the fundamental principle that a movable coil carrying a current in a magnetic field places itself in such a position

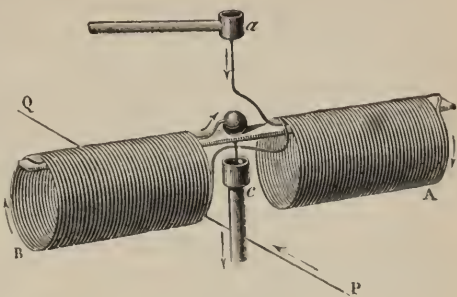

Fig. 893

that the maximum number of lines of force passes through it. For the earth's horizontal lines run from south to north, and therefore in the position of equilibrium the solenoid is full of the earth's lines.

If a current is passed through a wire PQ (fig. 893) stretched north and south under the solenoid, Oersted's experiment (835) may be repeated, the solenoid taking the place of the magnetic needle. If the direction of the current in PQ is from south to north, the north end (A) of the solenoid is deflected to the east, and takes up a new position of equilibrium under the combined action of the magnetic fields due to the earth and to the current in PQ. The result may also be regarded as an illustration of one of Ampère's fundamental laws—namely, that angular currents tend to become parallel and to flow in the same direction.

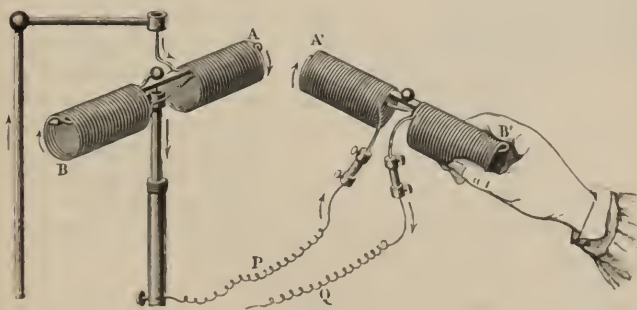

Fig. 894

The same phenomena of attraction and repulsion exist between solenoids and magnets as between magnets themselves. For if one of the poles of a magnet is presented to a movable solenoid traversed by a current, attraction or repulsion will take place, according as the poles of the magnet and of the solenoid are of contrary or of the same name. The same phenomenon

takes place when a solenoid traversed by a current and held in the hand is presented to a movable magnetic needle.

When two solenoids traversed by a current are allowed to act on each other, one of them being held in the hand and the other being movable about a vertical axis, as shown in fig. 894, attraction and repulsion will take place just as in the case of two magnets.

894. **Ampère's theory of magnetism.**—Ampère propounded a theory based on the analogy between solenoids and magnets, by which all magnetic phenomena may be referred to electrodynamic principles.

Instead of attributing magnetic phenomena to the existence of two fluids Ampère assumed that each individual molecule of a magnetic substance is traversed by an electric current, which circulates without meeting with resistance and therefore without the expenditure of energy. The molecular currents, which thus remain of constant strength, are free to move about the centres of the molecules. The coercive force, however, which is little or nothing in soft iron, but considerable in steel, opposes this motion, and tends to keep the molecular currents in any position in which they happen to be. When the magnetic substance is not magnetised, these currents, under the influence of their mutual attractions, occupy such positions that their total action on any external magnetic substance is null. Magnetisation consists in giving to these molecular currents a parallel direction, and the stronger the magnetising force the more perfect the parallelism. The *limit of magnetisation* is attained when the currents are completely parallel.

The resultant of the actions of all the molecular currents is equivalent to that of a single current which traverses the outside of a magnet. For by

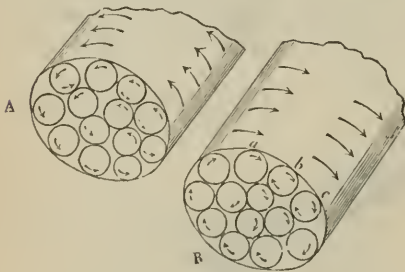

Fig. 895

inspection of fig. 895, in which the molecular currents are represented by a series of small internal circles in the two ends of a cylindrical bar, it will be seen that the adjacent parts of the currents oppose one another and cannot exercise any external electrodynamic action. This is not the case with the surface; there the molecular currents at *abc* are not neutralised by other currents, and as the points *abc*

are infinitely near, they form a series of elements in the same direction situated in planes perpendicular to the axis of the magnet, thus constituting a true solenoid.

895. **Terrestrial current.**—In order to explain terrestrial magnetic effects on this supposition, the existence of electric currents is assumed, which continually circulate round our globe from east to west perpendicular to the magnetic meridian. They are supposed by some to be thermo-electric currents due to the variations of temperature caused by the successive influence of the sun on the different parts of the globe from east to west.

These currents direct magnetic needles; for a suspended magnetic

needle comes to rest when the molecular currents on its under-surface are parallel and in the same direction as the terrestrial currents. As the molecular currents are at right angles to the direction of its length, the needle places its greatest length at right angles to east and west, or north and south. Natural magnetisation is probably imparted in the same way to iron minerals.

896. **Electrodynamometers.**—The principle of the *electrodynamometer* is that of determining the strength of a current by measuring the attraction or repulsion between parallel branches through which the current flows, one branch being fixed and the other movable. Fig. 896 represents the main features of a form devised by Siemens for this purpose; w is a coil of stout copper wire, and w' a single wire; nn are mercury cups, and kk binding screws, by which connection is made with the main circuit LL.

The wire w' is surmounted by a spiral spring f , which is connected at one end with this wire, and at the other with a torsion head, s ; the latter is provided with an index, z , which moves over a graduated scale, S. An index, $z'z'$, is also fixed to the wire w' ; on the right of the lower part of fig. 896 is seen the end of the wire $z'z'$, which projects and moves over the graduated disc, S. At the outset both indexes point to zero; when the current passes the movable coil tends to place its plane parallel to that of the fixed coil with the currents in the two flowing in the same direction, and the point z' is displaced along the scale. By turning the screw s it is brought back to zero, and the angle through which z is moved is a measure of the torsion of the spiral spring f , and this angle is proportional to the square of the strength of the current traversing the circuit.

This electro-dynamometer is not intended for the measurement of very minute currents; it has the advantage that its indications are independent of the external magnetic field, and when the two coils are traversed by the same current they are also independent of the direction of the current, and can accordingly be used with advantage in measuring alternating currents.

It will be noticed that the movable coil, $w'w'$, is always in the same position—viz. at right angles to the fixed coil—when a reading is taken, and, therefore, the electro-magnetic torque on the movable circuit, which is proportional to C^2 (since the current C flows both in the fixed and movable coils), is always exactly balanced by the torsion of the spiral spring which is proportional to the angle of torsion, that is $C^2 = k^2\theta$, or, $C = k\sqrt{\theta}$, where k is a constant and θ the angle through which the torsion head has been turned. If a current, whose strength in amperes is known, is passed through the instrument, and θ is noted, k is determined.

An electro-dynamometer devised by Giltay on a principle first introduced by Bellati is remarkable for its great sensitiveness. A bundle of fine iron wires hangs by a bifilar suspension inside a galvanometer coil, the plane of which is at an angle of 45° with the magnetic meridian. The bundle



Fig. 896

itself is at an angle of 45° with the plane of the coils, and is thus at right angles to the magnetic meridian. When alternating currents are passed through the coil they magnetise the wires with alternate poles, so that the bundle is always deflected in the same direction. The deflections are read off by a mirror and scale, and when small are directly proportional to the square of the current. The apparatus is so sensitive that deflections of 18 cm. on the scale, placed at the usual distance from the mirror of the instrument, are produced by the currents of an ordinary telephone.

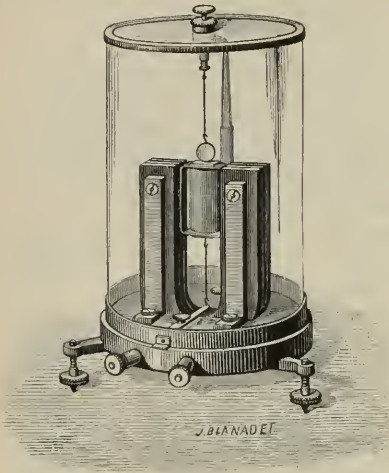

Fig. 897

In Lord Kelvin's Ampere Balance the attraction between two parallel coils, through which the current to be measured passes, is *weighed*. The apparatus consists of a balance beam, pivoted at the centre, in a manner to be presently described, and carrying a flat horizontal coil at each end. Above and below each of these terminal coils is a fixed coil, so that there are altogether six coils, of which four are fixed and two move in the spaces between the fixed coils, and the current to be measured flows through all of them. The wire is so wound that the coil at one end of the beam is repelled by the upper, and attracted by the lower fixed coil, while that at the other end is attracted by the upper, and repelled by the lower coil. The deflected beam is restored to the horizontal position by means of a sliding weight, and the position of the latter on the beam enables the strength of the current to be determined. The instrument really measures the *square* of the strength of the current, since the current flows through both the attracting and attracted coils.

The chief difficulty in instruments of this class is to provide means for the current to enter and leave the moving coil or coils. In Siemen's Electrodynamometer the device of mercury cups is adopted, but this is unsatisfactory in many ways. In the ampere balance the beam is suspended by two sets of fine parallel copper wires, through which the current enters and leaves the moving system. These copper-wire *ligaments* are extremely flexible, and leave the beam almost as much freedom as if it were suspended on knife-edges; and the number of wires in the ligament can be increased, without affecting its flexibility, so as to enable it to carry a strong current.

897. Suspended coil galvanometer.—In the galvanometers already described (841), the coils through which the current passes are fixed, and the needle is movable. A suspended coil galvanometer is one in which a fixed and strong magnetic field is provided by a permanent steel

magnet between the poles of which is suspended a coil carrying the current to be measured. The coil when traversed by a current tends to place itself at right angles to the field.

To this class belong the galvanometers of Deprez and D'Arsonval represented in fig. 897. Between the branches of a strong horseshoe magnet is a soft-iron cylinder, which is supported independently and becomes magnetised by induction. Between this and the magnet is a light rectangular wire coil, supported above and below by wires conveying the current into and out of the moving coil. When the current passes, the coil is deflected and equilibrium is established when the electromagnetic torque is equalled by the torsion of the wire. The motion of the coil can be read off by a spot of light reflected from a mirror (532) attached to it, and for small angles the current is proportional to the angle of deflection. Induction currents due to the motion of the coil in the field are produced when the circuit is closed, and these are greater the less the resistance. When the circuit is closed by a small resistance the galvanometer is virtually dead-beat (963). Dead-beat action is secured, independently of the resistance in the wire circuit, by winding the coil on a light metallic (*e.g.* aluminium) frame.

These instruments are practically independent of external magnetic fields, and may therefore be used in the neighbourhood of dynamos.

898. **Weston Ammeter.**—The principle of this instrument is the same as that of the D'Arsonval galvanometer already described. Fig. 898 shows the instrument with the cover Y (fig. 899) removed, while fig. 900, which is on a larger scale, enables the coil and pole-pieces to be seen. The aluminium frame on which the coil is wound, instead of being suspended by wires, is pivoted top and bottom in jewelled centres, J, and controlled by two hair-springs, S, S, made of non-magnetic material, the springs also serving to lead the current into and out of the moving coil. To the ends of the horseshoe magnet M, M, curved iron pole-pieces, P, P, are attached, and in the centre of the moving coil is a stationary soft-iron cylinder I, so that the lines of magnetic force in the region in which the coil moves are nearly radial. A long pointer attached to the coil moves over the scale, X, which is graduated in amperes, or fractions of an ampere. The instrument illustrated is a *milli-ammeter*, the divisions on the scale being milli-amperes, or thousandths of an ampere. The clearance—that is, the space between the poles P, P, and the core I, in which the coil moves—is very small. This enables the magnetic field to be made strong, and constant in strength. The instrument is dead-beat, and as the moving system is carefully balanced, may be used in any position.

899. **Wattmeter.**—A wattmeter is an instrument for measuring the power absorbed by any conductor or circuit when an electric current passes through it. If C is the current in the conductor or circuit in amperes, and e the difference of potential between its ends in volts, Ce is the power absorbed, in watts. C and e might, in the case of continuous currents, be measured separately by an ammeter and voltmeter respectively, and the values multiplied together to give the watts. A wattmeter gives the product directly. It is essentially an electro-dynamometer, in which, however, the fixed and movable coils, instead of being in series with each other, are entirely separate. Wattmeters are chiefly used with alternating currents, since their indications

give the real power expended in a circuit, which is generally less than the product Ce on account of the difference in phase between the E.M.F. and the current.

One of the coils, of low resistance, is in series with the circuit in question; the other, of high resistance, is in parallel with the circuit. Since the

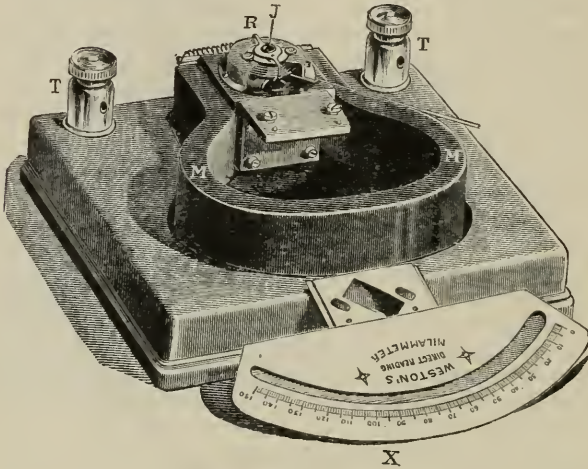

Fig. 898

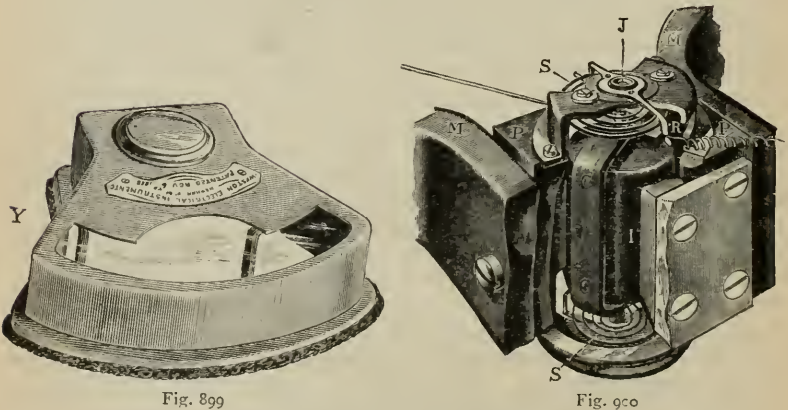

Fig. 899

Fig. 900

From Ayrton's 'Practical Electricity'

current in the high-resistance coil is proportional to the difference of potential, e , at its ends, and since the torque on the movable coil, when restored by torsion to its zero position, is proportional to the product of the currents in the two coils, it follows that the angle through which the pointer, attached to the torsion head, has been moved, is proportional to Ce .

900. **Hall's experiment.**—In the action of magnets on currents which has been described in the foregoing sections, we have been concerned with the action of the magnet on the body which conveys the current.

Professor Hall of Baltimore has made the following experiment to determine whether the path of a current itself in the body of a conductor is or is not deflected when it is exposed to the direct action of a magnetic field. A strip of gold leaf AB, 9 centimetres in length by 2 centimetres broad (fig. 901), is fastened on a glass plate placed between the poles of an electro-

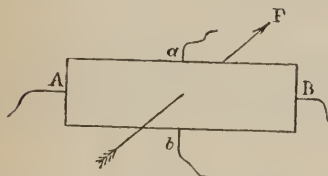

Fig. 901

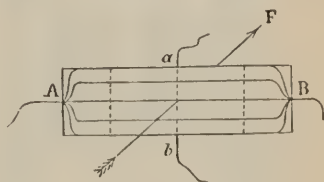

Fig. 902

lines of force of the magnetic field. A difference of potential of from 1 to 2 volts is established between the ends A and B. Two wires leading to a galvanometer *a* and *b* are connected with two equipotential points at the opposite edges of the strip; that is to say, at two points, found by trial, in which there is no deflection in the galvanometer. Fig. 902 shows the general direction of the lines of flow of the current when the electromagnet is not excited, the dotted lines being equipotential lines. When the electromagnet is excited by passing a current through it, a distinct deflection is produced in the galvanometer, showing that the position of the equipotential lines is varied (fig. 903), and that the paths of the current in the conducting

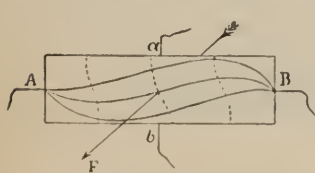

Fig. 903

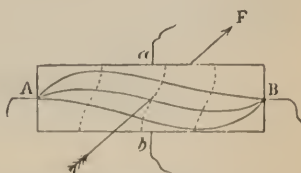

Fig. 904

strip have been deflected. This deflection is permanent, and cannot therefore be due to induction, and its direction is reversed when the current in the electromagnet is reversed (fig. 904).

The magnetic field acts thus upon the current in the gold leaf in such a manner as to displace it towards one edge or the other, and to cause a small portion to pass through the circuit of the galvanometer.

The electricity is displaced in the direction of the electromagnetic force, due to the magnet, from *a* to *b* through the galvanometer in the case of iron, zinc, and cobalt, but from *b* to *a* through the galvanometer, with nickel, gold, and bismuth. Of all metals, bismuth shows the phenomenon in far the highest degree.

CHAPTER VII

ELECTROMAGNETS. MAGNETISATION OF IRON. TELEGRAPHS

901. **Electromagnets.**— If insulated copper wire is wound in the form of a spiral on a tube of non-magnetic material, and a current is passed through it, the spiral becomes a magnet. Such an arrangement is commonly called a solenoid, though it does not strictly conform to the conditions for a solenoid laid down in article 893.

The coil is said to be right-handed (fig. 905) or left handed (fig. 906), according as the direction of the successive turns, to an observer looking at one end, is with or against the motion of a clock hand.



Fig. 905

But whatever the direction of the coiling, the polarity is easily found by the following rule: *If a person swimming in the current looks at the axis of the spiral, the north pole is always on his left.* If the wire is not coiled regularly, but if its direction is reversed, at each change of direction a consequent pole (706) is formed in the magnet. The simplest method of remembering the polarity produced is as follows: What-



Fig. 906

ever be the nature of the helix, whether right or left handed, if the end facing the observer has the current flowing in the direction of the hands of a watch it is a *south* pole, and *vice versa*. The lines of force pass through the interior of the coil in straight lines, emerge at the north pole and, spreading round, enter again at the south pole, each line of force being a continuous curve. If the coil contains an iron core, the latter becomes magnetised, its polarity being the same as that of the coil; but the lines of force are considerably increased in number. An arrangement of a long length of copper wire wound on a bar or *core* of soft iron forms what is called an *electromagnet*. The magnetisation of the iron is only temporary; when the current ceases the magnetisation ceases also, and the iron reverts almost wholly to its ordinary magnetic but unmagnetised condition.

From its property of producing a powerful magnetic field, the coil in

this experiment constitutes a *magnetising coil or spiral*; and the magnetisation of the iron by its means is an application of the principle of magnetic induction. From the fact that electromagnets are far more powerful than permanent magnets, and still more, that their magnetisation can be instantaneously evoked and destroyed, they have met with a host of applications of the very greatest importance; and the form, dimensions, and strength of such electromagnets vary greatly with the purpose for which they are intended.

There are, however, two principal types: *bar magnets*, as in fig. 905, or *horseshoe magnets*, either in one piece, as shown in fig. 907, or else formed of two straight electromagnets, each joined to a cross-piece of soft iron or *yoke*, T, as shown in fig. 909. It is better to have the iron in one piece, but the bending of large masses is difficult, and is apt to increase the coercive force, so that the other plan is generally adopted, great care being taken that the surfaces in contact be very accurately fitted to each other.

In order that the poles at the two ends may be of opposite kinds, the wire must go round each branch in the same direction as it would do if the core had been bent after the winding had been finished. The windings ought to appear in opposite directions on the two legs to an observer who is looking at the two ends (fig. 908), the current going like the hands of a watch round the south pole, and in the opposite direction round the north pole. Fig. 910 represents a compact form

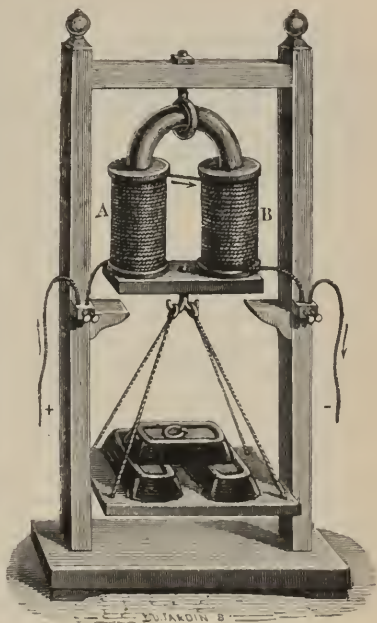

Fig. 907

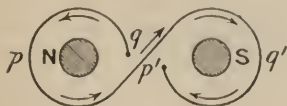

Fig. 908

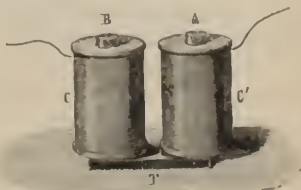

Fig. 909

of electromagnet devised by Joule, the core and armature of which may be constructed by sawing a piece of wrought-iron tubing lengthwise. There must be space enough to contain the wire necessary.

The magnetism in solid and in hollow cylinders of the same diameter is

the same, provided in the latter case there is sufficient thickness of iron for the development of the magnetisation. With currents below a certain strength, wide tubes of sheet iron are far more powerfully magnetised than solid rods of the same length and weight; but with more powerful currents the magnetism of the latter preponderates.

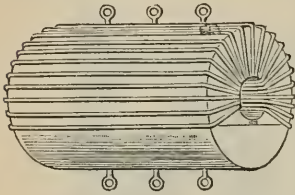

Fig. 910

902. **Magnetic force inside a magnetising coil.** **Magnetomotive force.**—The magnetic force, that is, the force on unit pole, is the same at all points in the interior of a long coil, except near the ends; and, further, is independent of the diameter of the coil. Its value is $4\pi n_1 C_1$, where n_1 is the number of turns per centimetre of length of the coil, and C_1 is the current in absolute measure. If l is the length of the coil, supposed to be wound uniformly, n the total number of turns, $n = n_1 l$, and if the current C is measured in amperes, then, since 10 amperes are equal to 1 absolute unit of current, the magnetic force, or strength of the magnetic field, inside the coil is $\frac{4\pi n C}{10l}$. Let this be called H . When there is no iron in the coil this expression gives also the number of lines of force per square centimetre of cross-section; but if the coil surrounds an iron core the number of lines is increased to an extent corresponding to the increased permeability (721). If B represents the magnetic induction, and μ the permeability,

$$B = \mu H = \frac{4\pi \mu n C}{10l}.$$

If a soft-iron ring or *tore* is coiled round with insulated wire through which a current is passed, it is the seat of a very powerful magnetic induction, though it has no poles, and therefore no external action. Such a system forms a closed *magnetic circuit*; the arrangement represented in fig. 907, where the two poles of an electromagnet are connected by an armature, also forms such a circuit, and an interesting analogy may be made between it and a closed *electric circuit*.

For if N represents the total number of lines passing through the iron whose cross-section is S , $N = BS$,

$$\text{therefore } N = BS = \frac{4\pi \mu n C S}{10l} = \frac{4\pi n C / 10}{\frac{l}{\mu S}} = \frac{M}{Z},$$

an expression analogous to Ohm's formula for currents—viz. $C = \frac{E}{R}$. M is called the *magnetomotive force*, and Z the *magnetic resistance* or *reluctance*. The magnetomotive force is the product of current and total number of turns of wire multiplied by a constant; the reluctance varies directly as the length, and inversely as the cross-section of the iron, and also inversely as μ , the permeability of the iron. The reciprocal of μ is the *specific reluctance* of the iron, corresponding to specific resistance in the analogous case. If N ,

the total number of wires passing through the iron, is called the *magnetic flux*; the above relation may be written

$$\text{magnetic flux} = \frac{\text{magnetomotive force}}{\text{reluctance}}.$$

Flux-density is a better term for B than *magnetic induction*.

The analogy between electric and magnetic circuits also holds if we consider the magnetic circuit as made up of bodies of different permeabilities ;

Z in this case being the sum of expressions like $\frac{l}{\mu S}$. For example, in the

Weston ammeter (898) the magnetic circuit consists of the steel magnet M, the pole-pieces P P, the iron cylinder P, and the two air-gaps separating the pole-pieces from the cylinder ; for each of these l , μ , and S must be determined, and as the reluctance of air is very great as compared with that of iron or steel, we see the importance of making the air-gap as narrow as possible.

The analogy fails, however, in one important respect ; electric resistance is quite independent of electromotive force, while the permeability of a magnetic substance depends upon the value of the magnetomotive force. Hence the analogy is rather formal than real ; it is, however, useful in dealing with calculations about electromagnets.

The expression $4\pi nC$ shows that we get the same magnetic effect whether we have a small number of turns of wire with a strong current, or a great number of turns with a weak current. Thus, with a given bar the same effect is produced by one turn conveying a current of one ampere as by ten turns with a current of one-tenth of an ampere. In the case of electromagnets the magnetising force is usually defined by the number of *ampere-turns* used.

Taking the permeability of air as unity, that of iron is many hundred times as great ; hence the introduction of a layer of air in a magnetic circuit is analogous to the introduction of a bad conductor in an electric circuit. Iron being the most permeable of all substances, a magnetic circuit should have as much iron as possible. The junctions also should be made close and true, since each joint increases the magnetic reluctance.

903. **Ammeters.**—A variety of instruments have been constructed for measuring current, which depend upon the principle that a piece of iron partially or entirely enclosed in a coil through which the current passes strives to place itself in the strongest part of the magnetic field thereby created, the tendency being approximately proportional to the strength of current. A pointer attached to the piece of iron, and moving over a graduated scale, serves to indicate the strength of current. The control, that is, the force opposing the motion of the iron, is supplied either by a spring or a weight. Instruments of the latter class are called gravity ammeters. We proceed to describe one of these, devised by Mr. Evershed. Its working parts are shown in figs. 911 and 912. Along the axis of the coil is a staff, SS, pivoted in jewelled bearings, carrying near one end the pointer, PP, and controlling weight, W. Rigidly attached to this is the *needle* AB, a half-cylinder of thin-sheet soft iron. This is enclosed in a *fixed* brass cylinder, TT, seen in fig. 912, but removed from fig. 911. Another soft-iron

cylinder or collar, CD, part of which is cut away, and which, consequently, has the shape shown in fig. 911, fits closely on the outside of the brass tube. Fig. 911 shows the relative positions of the iron needle AB, and the iron collar CD, when the index points to zero of the scale, that is, when no current is passing. When a current flows round a coil, the needle is pulled round magnetically, so as to fill up, to a greater or less extent, the space where the iron has been cut away from the collar CD, its motion being controlled by the weight W, which is rigidly attached to the axis. The scale is

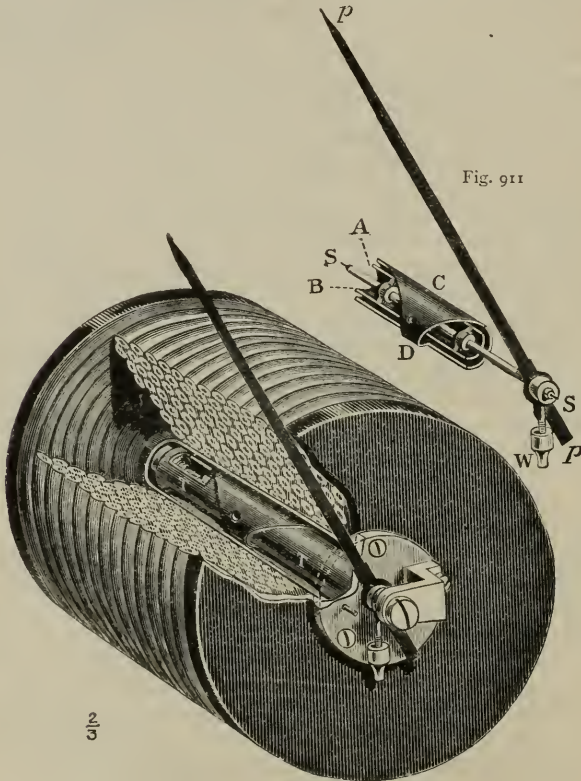

Fig. 911

Fig. 912

From Ayrton's 'Practical Electricity'

graduated empirically. Ammeters with gravity control must be rigidly fixed, and are generally secured to a vertical wall. In instruments to be used on board ship a spring control is substituted.

An ammeter, devised by Professors Ayrton and Perry, depends on the principle that when a portion of an iron core is partly within and partly without a magnetising coil, it is drawn inwards when a current is passed through the coil. The magnetic field not being uniform, the iron is urged towards the strongest part of the field. The essential feature of the

apparatus is a coil of insulated wire, in the axis of which is a spiral attached at one end to an index moving over a graduated scale. At the other end of the spiral is a brass cap to which is attached a thin cylinder of sheet iron, which is in fact the core; it encircles the spiral and projects outside the coil. The spiral itself is formed of a ribbon of thin phosphorus bronze coiled so as to form a very narrow cylinder. This construction gives it the property that, unlike ordinary spirals, when its length increases the free end rotates through a considerable distance. Accordingly, when the current passes through the coil, the iron tube is drawn within the spiral to an extent varying with the strength of the current; this thereby elongates the spiral to which it is attached, and the index attached to the latter moves over the scale, finally taking up a position which depends on the strength

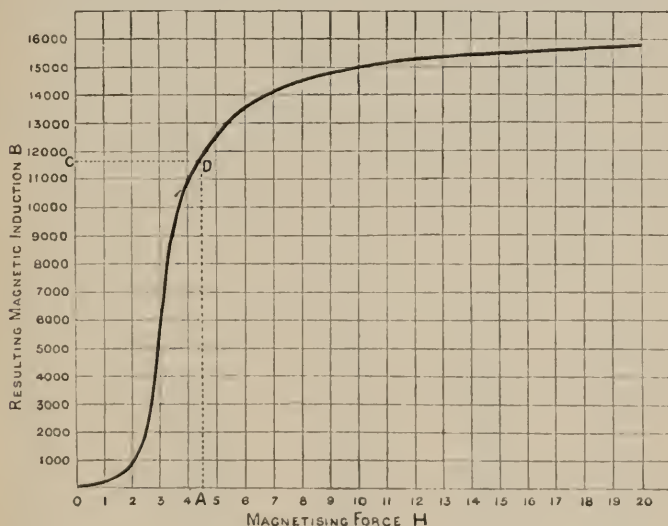

Fig. 913

From Slingo and Brooker's 'Electrical Engineering'

of the current. Such instruments are graduated empirically and within any desired range by observing the deflection caused by passing through them currents of known strength.

904. **Magnetisation curve.**—If we take a given magnetising spiral, at right angles to the magnetic meridian, and place at some distance from it, and in the line of its axis, a small magnetic needle, on passing a current through the spiral the needle is deflected, and this deflection (or, more strictly, its tangent) is a measure of the magnetic moment acquired by the spiral (724); if the current is gradually increased the deflection will also be increased, and in proportion to the strength of the current.

If, however, the spiral contains a bar of soft iron, the case is not so simple. On plotting the curve which represents the ratio of the magnetising force to the magnetisation, as measured by the deflection of the needle, it will be

found that at first the magnetisation is proportional to the magnetising force ; then a stage is reached when the magnetisation increases more rapidly than in direct proportion to the magnetising force, but the rate of increase gradually becomes less, and the magnetisation ultimately approaches a limit which is not materially exceeded, even by a considerable increase in the magnetising force. This represents a state of saturation (698), and it corresponds to the case in which the axes of the molecular magnets are all strictly parallel to the axis of the spiral.

The following table gives a number of results obtained for a specimen of soft iron examined by Professor Ewing by the above method, which is known as the *magnetometer method*. In the first column magnetising forces (H), which are directly proportional to the magnetising current, are given. From the deflection of the magnetometer needle the magnetic moment of the iron can be deduced, and hence the intensity of magnetisation (I) of the iron, since $I = \frac{\text{magnetic moment}}{\text{volume}}$. The values of I are given in the second column. The third column contains the values of the magnetic susceptibility of the iron, obtained by dividing I by H. The values of B are obtained from the formula $B = H + 4\pi I$, and those of μ by dividing B by H (see arts. 721, 722).

H	I	$\kappa = \frac{I}{H}$	B	$\mu = \frac{B}{H}$
·32	3	9	40	120
·84	13	15	170	200
1·37	33	24	420	310
2·14	93	43	1,170	550
2·67	295	110	3,710	1,390
3·24	581	179	7,300	2,250
3·89	793	204	9,970	2,560
4·50	926	206	11,640	2,590
5·17	1,009	195	12,680	2,450
6·20	1,086	175	13,640	2,200
7·94	1,155	145	14,510	1,830
9·79	1,192	122	14,980	1,530
11·57	1,212	105	15,230	1,320
15·06	1,238	82	15,570	1,030
19·76	1,255	64	15,780	800
21·70	1,262	58	15,870	730

This table presents many points of interest, some of which are better seen when the results are plotted in the form of a curve. This has been done in fig. 913, in which abscissæ represent magnetising forces (H), and ordinates represent corresponding values of B, the magnetic induction. Near the origin the curve is a straight line, showing that the magnetism produced by a small force is proportional to the force. The change in the magnetising force from 2 to 5 units causes an extremely rapid rise in the resulting magnetisation, but as the magnetising force is further increased the curve tends to become parallel to the axis of magnetising force. When this parallelism is attained the iron is saturated with magnetism, and

its permeability is unity. The last column in the table shows that the permeability of soft iron increases with the magnetic field, and then diminishes. Its maximum value, 2590, was reached when the magnetising force was 4.5, and when this was raised to 21.7 the permeability fell to 730. Ewing and others, applying magnetising forces as high as 20,000 to wrought iron, reduced its permeability to nearly 2.

The intensity of the magnetisation which can be imparted to a bar is about 1700 C.G.S. units in the case of wrought iron, 1240 with cast iron, and 515 in the case of nickel. Steel can acquire pretty much the same intensity of magnetisation as wrought iron, and retains about one-half in the form of permanent or residual magnetism. Soft iron almost wholly loses its magnetisation when the current ceases, and the more so the purer the iron, and the more carefully it is annealed. In many applications it is of great importance that the cessation of the magnetisation with the current should be as complete as possible. *Permanent* and *residual* magnetism are in fact the same, but the former expression is used when it is desired to retain the magnetism, and the latter when its presence is objectionable.

Residual magnetism is greater in long magnets, that is to say, those in which the diameter is small in comparison with the length. Hence for rapid demagnetisation the core should be short and thick. A bundle of soft-iron wires is more rapidly demagnetised than a massive bar of the same size. Residual magnetism is greater when the magnetising current is not stopped suddenly, as is usually the case, but is gradually brought back to zero by successively introducing increasing resistances.

905. **Portative force.**—The attraction between a magnet and a soft-iron keeper (710) depends only on the area of the surfaces in contact, and on the magnetic induction (or flux-density) B . If S represents the area, and if a weight of M grammes is required to drag the keeper from the magnet, the attractive force = Mg dynes, where $g = 981$ (81), and $Mg = \frac{SB^2}{8\pi}$.

When an armature is not in contact with the poles the attraction diminishes very rapidly with the distance; for in the first place the attraction is inversely proportional to the distance, and then the effect of this distance is to introduce a layer of air which from its very great reluctance greatly lessens the induction in the magnetic circuit.

According to the researches of Bidwell, it appears that for low degrees of magnetisation the portative force increased less rapidly than the current strength up to a certain point, at which the field was about 240 units and the load supported 14,000 grammes per square centimetre. From this point the magnetising current and the load increased in the same ratio. When the field had an intensity of 585 units, the greatest weight supported was 15,900 grammes per sq. cm., or 226 pounds per square inch.

906. **Change of length of an iron rod in a magnetic field.**—Joule found (698) that under a magnetising force which he considered sufficient to saturate the iron, but which appears to have been less than 100 units, the length of an iron bar was increased by $\frac{1}{270000}$. When the bar with its coil was placed in a sort of water thermometer consisting of a glass flask provided with a capillary tube, Joule found, using the same magnetising force as before, that, allowing for the expansion of water due to the heat of the

current, there was no motion in the capillary tube; from this he concluded that the volume of the iron was unaltered by magnetisation, and also that since its length was increased, its diameter must have diminished.

In Shelford Bidwell's investigation of these phenomena, a far higher magnetising force was employed (up to nearly 1500 units), and the results showed that Joule's conclusions required modification.

Bidwell found that the length of a rod of soft iron increased as the magnetising force was raised to 80 units and then diminished, regaining its original value when the magnetising force was about 300 units. Beyond this point the iron rod contracted, and continued to do so until the magnetising force was about 1000 units, after which it remained constant. The maximum elongation varied in different specimens, ranging from the $\frac{200000}{1000000}$ to the $\frac{400000}{1000000}$ part of the length of the rod. The amount of the retraction under strong force was $\frac{1000000}{1000000}$ of the length. The diameter of the rod is also changed; with small forces it is diminished, and with large forces increased, but the longitudinal and transverse changes of dimensions are not often related in such a manner as to leave the volume of the bar unaltered. A magnetising force of 80 or 90 units has indeed generally no effect upon the volume; with a smaller force, however, the volume is diminished, while with a larger one it is increased. Steel behaves in much the same way as iron, but suffers less elongation under moderate forces. The behaviour of cobalt is the reverse of that of iron, contracting under small and lengthening under great magnetic forces. A nickel rod is always shortened, whether the magnetising force is great or small.

907. **Cyclic changes. Magnetic hysteresis.**—Suppose that a rod of iron, absolutely free from permanent magnetism, has been subjected to gradually increasing magnetising forces and that its magnetisation curve is represented by OA (fig. 914), in which, as before, abscissæ represent magnetising forces, and ordinates the corresponding magnetisations. If at the point A the magnetising force is gradually diminished, the curve OA is not retraced, but the ordinates of the descending curve are greater than those of the ascending curve for equal values of the current. When the current is zero there is still a certain amount of magnetisation left (residual magnetism), and to reduce this to zero a magnetising force must be applied in the opposite direction. Let this force be increased to $-F$, then diminished to zero, and then increased positively until the point A is again reached.

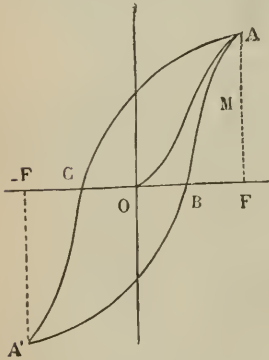

Fig. 914

The iron is now in the same state as it previously was at the point A, having passed through a complete cycle of changes. It may be shown that the area of the loop, ACA'BA', is a measure of the energy which has been spent in carrying each cubic centimetre of the iron through the cycle—that is, the difference between the energy spent in magnetising and that which is recovered in the reverse process.

It will thus be seen that the magnetisation of a bar for a given force

depends not only on its existing condition, but also on its previous state. The magnetisation is greater in the descending than in the ascending period for the same value of the magnetising force. This is due to residual magnetisation; there is a *retardation* or *lag* of the magnetisation in respect of the magnetising force, to which Prof. Ewing has applied the term *hysteresis*. The hysteresis is greater the wider the difference in the two curves. Hysteresis is diminished if the body is submitted to vibrations during the process of magnetisation.

When a soft-iron bar is submitted to magnetisations and demagnetisations in rapid succession, its temperature rises. The energy lost in each cycle is transformed into heat. The loss may attain 15,000 ergs per cubic centimetre of soft iron for each complete cycle, and the term *hysteresis* is used to express this loss as well as to represent generally the phenomenon of magnetic retardation. One erg represents 238×10^{-7} calories (506), and since the density of iron is 7.8, and its specific heat 0.11 (464), the calorific capacity of a cubic centimetre is 0.858. So that, taking the above number, we have 0.0004° as the rise in temperature for each complete cycle. The *coercive force* of the magnetic substance is expressed numerically by the length CO or $\frac{1}{2}$ CB.

908. **Vibratory motion and sounds produced by currents.**—When a rod of soft iron is magnetised by a strong electric current, it gives a very distinct sound, which, however, is only produced at the moment of closing or opening the circuit. This phenomenon arises from a sudden motion of the molecules of iron due to magnetisation or demagnetisation.

When the circuit is broken and closed at very short intervals, De la Rive observed that, whatever be the shape or magnitude of the iron bars, two sounds may always be distinguished; one, which is musical, corresponds to that which the rod would give by vibrating transversely; the other, which consists of a series of harsh sounds, corresponding to the interruptions of the current, was compared by De la Rive to the noise of rain falling on a metal roof. The most marked sound is that obtained by stretching, on a sounding-board, pieces of soft-iron wire, well annealed, from 1 to 2 mm. in diameter and 1 to 2 yards long. These wires, being placed in the axis of a long magnetising coil traversed by powerful currents, send forth a number of sounds, which produce a surprising effect, and much resemble that of a number of church bells heard at a distance. Rods of zinc, copper, or brass give no note even with strong currents.

Wertheim also obtained the same sounds by passing a discontinuous current through the wires themselves. The musical sound is then stronger and more sonorous in general than in the previous experiment. The hypothesis of a molecular movement in the iron wires at the moment of their magnetisation and demagnetisation is confirmed by the researches of Wertheim, who found that their elasticity is then diminished.

909. **Reis's telephone.**—The essential features of this instrument (fig. 915) are a sort of box, B, one side of which is closed by a membrane, C, while there is a mouthpiece, A, in another side. On the membrane is a piece of thin metal-foil C, which is connected with a wire leading to one pole of the battery G, the other pole of which is put to earth. Just above the foil, and almost touching it, is a metal point D, which is connected by the line wire

(912) with one end of a coil of insulated wire surrounding an iron rod, the other end of the wire being put to earth.

When the mouthpiece is spoken or sung into, the sounds set the membrane in vibration ; this coming into contact with the point D causes a rapid

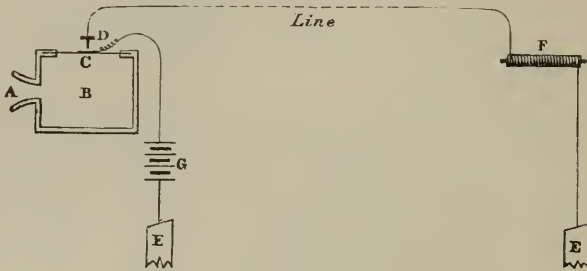

Fig. 915

succession of currents to pass into the line and through the electromagnet in which the corresponding sounds are produced.

910. **Electric bell.**—One form of this instrument is represented in fig. 916. On a wooden board arranged vertically is fixed an electromagnet, E ; the line wire is connected with the binding screw, *m*, with which is also connected one end of the wire of the electromagnet ; the other end is connected with a spring, *c*, to which is attached the armature, *a* ; this again is pressed against by a spring, C, which in turn is connected with the binding screw *n*, from which the wire leads to earth.

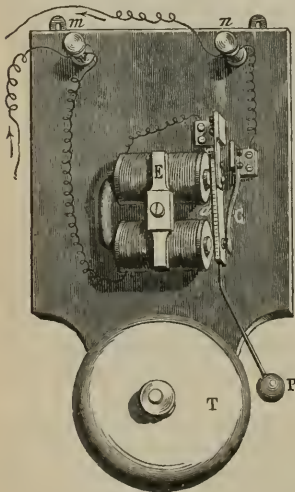

Fig. 916

Whenever the current passes, which is effected by a small contact-maker called a *push*, the armature *a* is attracted, carrying with it a hammer, P, which strikes against the bell T and makes it sound. The moment this takes place, contact is broken between the armature *a* and the spring C, and the current being stopped the electromagnet does not act ; the spring *c*, however, in virtue of its elasticity, brings the armature in contact with the spring C, the current again passes, and so on as long as the current continues to pass.

911. **Electric clocks.**—Electric clocks are clockwork machines, in which an electromagnet is both the motor and the regulator, by means of an electric current regularly interrupted, in a manner resembling that described in the preceding paragraph. Fig. 917 represents the face of such a clock, and fig. 918 the mechanism which works the needles.

An electromagnet, B, attracts an armature of soft iron, P, movable on a pivot *a*. The armature P transmits its oscillating motion to a lever, *s*, which

by means of a ratchet, *n*, turns the wheel A. This, by the pinion, D, turns the wheel C, which by a series of wheels and pinions moves the hands. The small one marks the hours, the large one the minutes; but as the latter does not move regularly, but by sudden starts from second to second, it follows that it may also be used to indicate the seconds.

It is obvious that the regularity of the motion of the hands depends on the regularity of the oscillations of the piece P. This is tested by connecting the clock in series with a standard, which itself has been previously regulated by a seconds pendulum. At each oscillation of the pendulum there is an arrangement by which the circuit is opened and closed, and thus the armature P beats seconds exactly.

To illustrate the use of these clocks, suppose that on the railway from London to Birmingham each station has an electric clock, and that from the London station a conducting wire connects all the clocks on the line to



Fig. 917

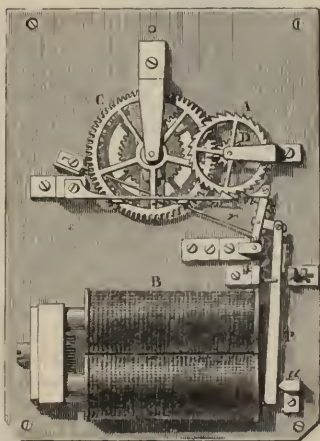

Fig. 918

Birmingham. When the current passes in this wire all the clocks will simultaneously indicate the same hour, the same minute, and the same second; for electricity takes an inappreciable time to go from London to Birmingham.

912. **Electric telegraphs.**—These are apparatus by which signals can be transmitted to considerable distances by means of voltaic currents propagated in metallic wires. Towards the end of the eighteenth century, and at the beginning of the nineteenth, many philosophers proposed to correspond at a distance by means of the effects produced by electric machines when propagated in insulated conducting wires. In 1811, Sæmmering invented a telegraph, in which he used the decomposition of water for giving signals. In 1820, at a time when the electromagnet was unknown, Ampère proposed to correspond by means of magnetic needles, above which a current was sent, as many wires and needles being used as letters were required. In 1834, Gauss and Weber constructed an electromagnetic telegraph in which a voltaic current transmitted by a wire acted on a magnetised bar, the oscillations of

which under its influence were observed by a telescope. They succeeded in thus sending signals from the Observatory to the Physical Cabinet in Göttingen, a distance of a mile and a quarter, and to them belongs the honour of having first demonstrated experimentally the possibility of electric communication at a considerable distance.

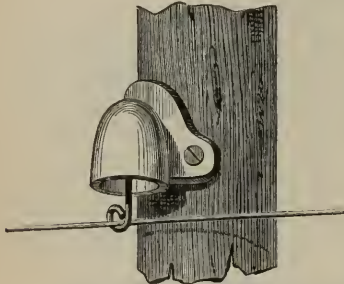

Fig. 919

In 1837, Steinheil in Munich, and Wheatstone in London, constructed telegraphs in which several wires each acted on a single needle; the current in the first case being produced by an electromagnetic machine, and in the second by a constant battery.

Every electric telegraph consists essentially of three parts: (1) a *circuit* consisting of a metallic connection between two places, and a battery or its equivalent for producing the current; (2) a *transmitter* for sending the signals from the one station; and (3) an *indicator* for receiving them at the other station. The mode of transmitting and receiving electric signals can be greatly varied, and we shall limit ourselves to a description of the three principal methods.

On the larger circuits dynamos or accumulators or combinations of the two are used; on smaller ones, where there is constant work, some form of Daniell's battery is used, and for other circuits Leclanché's cell is in extended use. In France, Daniell's battery is used for telegraphic purposes.

The connection between two stations is made by means of copper or galvanised iron wire suspended by porcelain supports (fig. 919), which insulate the wire and protect it against the rain; they are attached to posts or against the sides of buildings. In England and other moist climates special attention is required to be paid to the perfection of the insulation. In towns, wires covered with gutta-percha are placed in tubes laid in the ground. Submarine cables, where great strength is required combined with lightness and high conducting power, are formed on the general type of one of the Atlantic cables, a longitudinal view of which is given in fig. 920, while

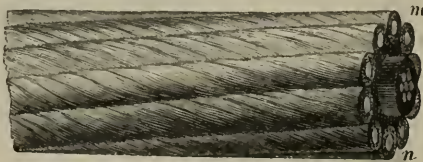

Fig. 920

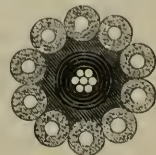

Fig. 921

fig. 921 represents a cross-section. In the centre is the *core*, which is the conductor; it consists of seven copper wires, each 1 mm. in diameter, twisted in a spiral strand and covered with several layers of gutta-percha, separated from each other by a coating of *Chatterton's compound*—a mixture of tar, resin, and gutta-percha. This forms the *insulator* proper, and it should have great resistance to the passage of electricity, combined with low specific

inductive capacity (783). Round the insulator is a coating of hemp, and on the outside is wound spirally a protecting *sheath* of steel wire, spun round with hemp.

At the station which sends the despatch, the line is connected with the positive pole of a battery, the current passes by the line to the other station, and if there were a second return line, it would traverse it in the opposite direction to return to the negative pole. In 1837, Steinheil made the very important discovery that the earth might be used for the return conductor, thereby saving the expense of the second line. For this purpose the end of the conductor at the one station, and the negative pole of the battery at the



Fig. 922

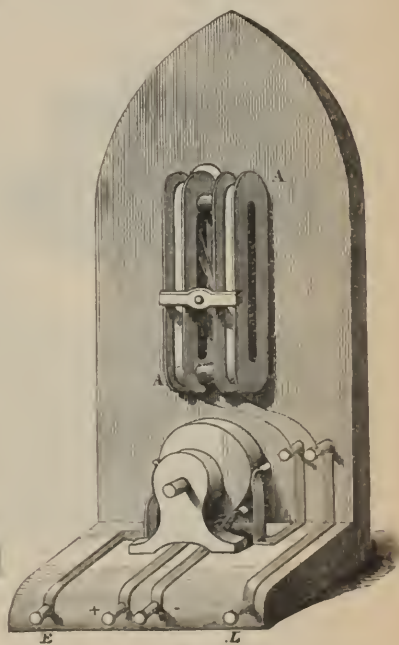

Fig. 923

other, are connected with large copper plates, which are sunk to some depth in the ground. The action is then the same as if the earth acted as a return wire. The earth is, indeed, far superior to a return wire; for the added resistance of such a wire would be considerable, whereas the resistance of the earth beyond a short distance is absolutely *nil*. The earth really *dissipates* the electricity, and maintains the earth plates at the same potential as the earth, so that there is practically no fall of potential between two earth plates connected with a circuit through which a current is flowing.

913. **Wheatstone and Cooke's single-needle telegraph.**—This consists essentially of a vertical galvanometer (840) with a single needle, the arrangement of which is seen in fig. 923, while fig. 922 gives a front view

of the case in which the apparatus is placed, and shows an index parallel to the needle. A (fig. 923) is the galvanometer coil consisting of about 400 feet of fine copper wire, wound on two bobbins.

The signs are made by transmitting the current in different directions through the galvanometer, by which the needle is deflected either to the right or left, according to the will of the operator. The instrument by which this is effected is a *commutator* or *key*, worked by a handle seen in front of fig. 922. When the handle is turned to the right the positive pole, and when it is to the left, the negative pole of the battery is put in connection with the line. If the handle is vertical, as shown, the battery is disconnected from the line.

Another form of sending apparatus, called a *tapper*, is similar to the *commutator* shown in fig. 924. There are two horizontal strips of springy

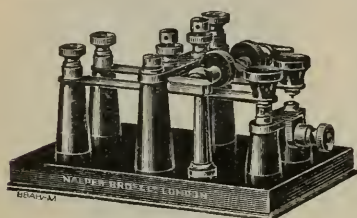

Fig. 924

brass, each of which is fixed at one extremity to the top of an ebonite pillar, where binding-screws are attached to them. At their other ends they are provided with ebonite pressure knobs, whereby each may be pressed into contact with the metal piece below, to which a binding-screw is also attached. Two other ebonite pillars are connected across the top by a brass bridge with a binding-screw at one end. The brass springs are in contact with this bridge unless one or other of the knobs is depressed. All metallic contacts are tipped with platinum. Of the two binding-screws at the left of the figure one is earthed, the other connected through the galvanometer to line; the other two, one in the middle, the other (low down) on the right, are connected to the poles of a battery. If neither knob is depressed the battery is not in action, and a current from the line, after traversing the galvanometer, passes from one strip through the bridge to the other and so to earth. By pressing the right- or left-hand knob, a positive or negative current may be sent into the line, the strip which is depressed being for the time disconnected from the bridge. The instrument illustrated in the figure is provided also with ebonite cams (not required for telegraphic purposes), for keeping either pole of the battery permanently connected with the circuit.

The signs are given by differently combined deflections of the needle as represented in the alphabet on the dial (fig. 922). \backslash denotes a deflection of the upper end of the needle to the left, and $/$ a deflection to the right; I, for instance, is indicated by two deflections to the left, and M by two to the right. D is expressed by right-left-left, and C by right-left-right-left, &c.

These signs are somewhat complicated, and complete mastery of them requires great practice: usually not more than 12 to 20 words can be sent in a minute. The single-needle telegraph was formerly sometimes replaced by the double-needle one, which is constructed on the same principle, but there are two needles and two wires instead of one.

914. **Morse's telegraph.**—The telegraph just described leaves no trace of the despatches sent, and if any errors have been made in copying the

signals there is no means of remedying them. These objections are met in the case of the *writing telegraphs*, in which the signs themselves are printed on a strip of paper at the time at which they are transmitted.

Of the numerous printing and writing telegraphs which have been devised, that of Morse, first brought into use in North America, is best known. It has been almost universally adopted on the Continent, and in England has nearly superseded the needle telegraph. In this instrument there are three distinct parts: the *receiver*, the *sender*, and the *relay*; figs. 925, 926, 927, and 928 represent these apparatus.

Receiver.—We will first describe the receiver (figs. 925 and 926), leaving out of sight for the moment the accessory pieces, G and P, placed on the right of the figure. The current which enters the indicator by the wire, C, passes into an electromagnet, E, which when the circuit is closed attracts an armature of soft iron, A, fixed near the end of a horizontal lever movable

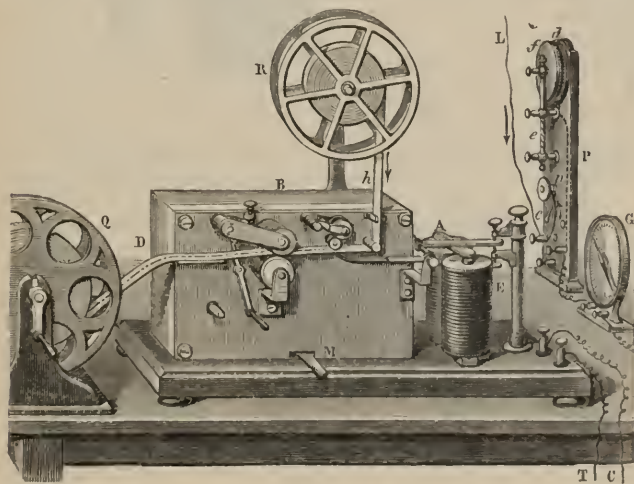

Fig. 925

about an axis, I; when the circuit is open the lever is raised by a spring. By means of two screws, *m* and *n*, the extent of movement of the lever is regulated. At the other end of the lever there is a blunt point which writes the signals. For this purpose a long band of strong paper, *hp*, rolled round a drum, R, passes between two copper rollers with rough surfaces, *u* and *t*, turning in contrary directions. Drawn in the direction of the arrow, the band of paper becomes rolled on a second drum, Q, which is turned by hand. A clockwork motion placed in the box, B, works the rollers, between which the band of paper passes.

The paper being thus set in motion, whenever the electromagnet works, the point strikes the paper, and, without perforating it, produces an indentation the shape of which depends on the time during which the point is in contact with the paper. If it only strikes it instantaneously it makes a *dot*

(-) or short stroke ; but if the contact has any duration, a *dash* (—) of corresponding length is produced. Hence, by varying the length of contact of the transmitting key at one station, the operator produces a combination of dots and dashes at another station, and it is only necessary to give a definite meaning to these combinations.

In order to make an indentation a considerable pressure is required, which necessitates the employment of a strong current, and the newer instruments

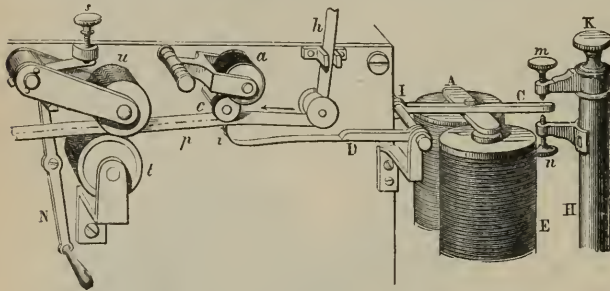

Fig. 926

(fig. 926) are based on the use of *ink-writers*. The paper band passes close to, but not touching, a metal disc with a fine edge, *c*, which turns against a small *ink-roller*, *a*, all

being rotated by the same mechanism. When the armature *A* is attracted, the bent plate at the other end of the lever presses the paper against the

PRINTING.	SINGLE NEEDLE.	PRINTING.	SINGLE NEEDLE.
A ---	✓	N ---	/\
B -----	/\	O -----	///
C -----	/\	P -----	✓/\
D ---	/\	Q -----	///
E -	\	R ---	✓/\
F -----	✓/\	S ---	✓
G -----	///	T ---	/
H -----	✓✓	U ---	✓/\
I --	✓	V -----	✓✓/\
J -----	✓///	W -----	✓/\
K -----	✓/\	X -----	/\
L -----	✓/\	Y -----	/\
M ---	///	Z -----	///

disc, which is inked by contact with the ink-roller, and thus produces a mark on the paper, which is either short or long according to the duration

of the contact. The signs are thus more legible, and are produced by far weaker currents.

The same telegraphic alphabet is now universally used wherever telegraphic communication exists; and the signals for the single-needle instrument (fig. 922) as well as those used for printing have been modified, so that they now correspond to each other. Thus a beat of the top of the needle to the left \ is equivalent to a dot: and a beat to the right / to a dash. The table on the preceding page gives the alphabet.

The *flag signals* employed in military operations are similarly used. A swing of the flag from its upright vertical position to the right or left has the same meaning as the corresponding motion of the top end of the needle. So, too, long or short obscurations of the limelight used in signalling by night, or of the heliograph (533), correspond to dashes and dots.

Morse key.—This consists of a small mahogany base, which acts as support for a metal lever *ab* (fig. 927), movable about a horizontal axis which passes through its middle. The end *a* of this lever is always pressed upwards by a spring beneath, so that it is only by pressing with the finger on the knob *B* that the lever strikes the platinum contact *x*. Round the base are three binding screws, one connected with the wire *P*, which comes from the positive pole of the battery; the second connected with *L*, the line wire; and the third with the wire *A*, which passes to the indicator; for of course two places in communication are each provided with an indicator and communicator.

These details known, there are two cases to be considered. 1. When a message is to be received, the contact *b* is down,

and a current arriving by the line wire passes into the lever of the key and thence by the contact *b* to the indicator. 2. A message is to be transmitted; in this case the knob *B* is pressed so that the lever comes in contact with the contact piece *x*, thereby establishing connection between the battery wire *P* and the line *L*, and cutting out the local indicator. According to the length of time during which *B* is pressed, a dot or dash is produced in the receiver to which the current proceeds.

Relay.—In describing the receiver we have assumed that the current of the line coming by the wire *C* (fig. 925) entered directly into the electromagnet, and worked the armature *A*, recording the signal; but when the circuit consists of many miles of wire, the current may be too weak to act upon the electromagnet with sufficient force to print a despatch. Hence it is necessary to have recourse to a *relay*—that is, to an auxiliary electromagnet which is still traversed by the current of the line, but which serves to introduce into the recording apparatus the current of a *local battery* of from 6 to 15 volts placed at the station, and which is only used to print the signals transmitted by the wire.

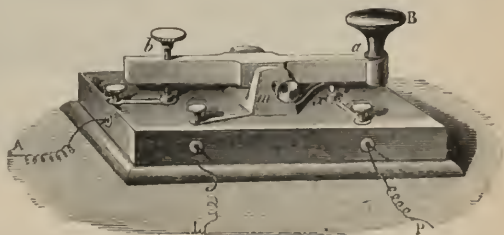

Fig. 927

Fig. 928 shows the relay. The current entering the relay by the binding screw, L, passes into an electromagnet, E, whence it passes into the earth by the binding screw T. Now, each time that the current of the line passes into the relay, the electromagnet attracts an armature, A, fixed at the bottom of a vertical lever, β , which oscillates about a horizontal axis.

At each oscillation the top of the lever β strikes against a button n , and at this moment the current of the local battery, which enters by the binding screw c , ascends the column m , passes into the lever β , descends by the rod o , which transmits it to the screw Z: thence it enters the electromagnet of the indicator, and returns to the local battery from which it started. Then, when the circuit of the line is open, the electromagnet of the relay does not act, and the lever β , drawn by a spring r , leaves the button n , as shown in the drawing, and the local current no longer passes. Thus

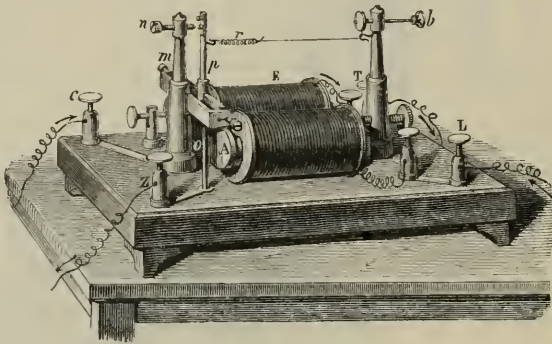

Fig. 928

the relay transmits to the indicator exactly the same phases of passage and intermittence as those effected by the manipulator in the station which sends the despatch.

With a general battery of 25 Daniell cells the current is usually strong enough at upwards of 90 miles from its starting-point to work a relay. For a longer distance a new current must be taken, as will be seen in the paragraph on the change of current (*vide infra*).

The three principal pieces of the Morse apparatus being thus known, the following is the actual path of the current.

The current of the line coming by the wire L (fig. 925) passes at first to the piece P intended to serve as lightning-conductor, when, from the influence of atmospheric electricity in time of storm, the conducting wires become so highly charged with electricity as to give dangerous sparks. This apparatus consists of two copper discs, d and f , provided with teeth on the sides opposite each other, but not touching. The disc d is connected with the earth by a metal plate at the back of the stand which supports this lightning-conductor, while the disc f is in the circuit. The current coming by the line L enters the lightning-conductor by the binding screw fixed at the lower part of the stand on the left; then rises to a commutator, n , which conducts it to a button, c , whence it reaches the disc f by a metal plate at

the back of the stand ; in case a lightning discharge should pass along the wire, it would now act inductively on the disc *d*, and emerge by the points without danger to the apparatus or the person manipulating it. Moreover, from the disc *f*, the current passes into a very fine wire insulated on a tube, *e*. As the wire is melted when the discharge is too strong, it acts as a safety fuse (859), and preserves the apparatus from damage.

Lastly, the current proceeds from the foot of the support to a screw on the right, which conducts it to a small galvanometer, *G*, serving to indicate by the deflection of the needle whether the current passes. From this galvanometer the current passes to a key (fig. 927), which it enters at *L*, emerging at *A* to go to the relay (fig. 928). Entering this at *L*, it works the electromagnet, and establishes the communication necessary for the passage of the current of the local battery, as has been said in speaking of the relay.

Change of current.—To complete this description of the Morse apparatus, it must be observed that in general the current which arrives at *L*, after having traversed several miles, has not sufficient force to register the despatch, or to proceed to a new distant point. The relay already described enables the telegraphic message to be registered by aid of the local battery. In order to transmit the signals to a more distant station another local battery of 20 or 30 cells is switched on by another relay, and passes the signals on through the further section of the line, without necessarily affecting the Morse instrument at the station itself.

915. **The sounder.**—The sound produced when the armature of the electromagnet in a Morse instrument is attracted by the passage of the current is so distinct and clear that many telegraph operators have been in the habit of reading the messages by the sounds thus produced. When necessary their reading could be checked by comparison with the signs produced on the paper.

Based on this fact a form of instrument invented in America has come into use for the purpose of reading by sound. The *sounder*, as it is called, is essentially a small electromagnet on an ebonite base, resembling the relay in fig. 928. The armature is attached to one end of a lever, and is kept at a certain distance from the electromagnet by a spring. When the current passes, the armature is attracted against the electromagnet with a sharp click, and when the current ceases it is withdrawn by the spring. Hence the interval between the sounds is of longer or shorter duration according to the will of the sender, and thus in effect a series of short or long intervals which represent short and long sounds can be produced which correspond to the dots and dashes of the Morse alphabet. Such instruments are simple, easily adjusted, and portable, not occupying more space than an ordinary field-glass. They are coming into extended use, especially for military telegraph work.

916. **Induction in telegraph cables.**—In the earliest experiments on the use of insulated subterranean wires for telegraphic communication it was found that difficulties occurred in their use which were not experienced with overhead wires. This did not arise from defective insulation, for the better the insulation the greater the difficulty. It was suspected by Siemens and others that the retardation was due to statical induction taking place

between the inner wire through the insulator and the conducting sheath ; and Faraday proved that this was the case by the following experiments among others. A length of about 100 miles of gutta-percha-covered copper wire was immersed in water, the ends being led into the observing-room. When the pole of a battery containing a large number of cells was momentarily connected with one end of the wire, the other end being insulated, and a person simultaneously touched the wire and the earth contact, he obtained a violent shock.

When the wire, after being in momentary contact with the battery, was placed in connection with a galvanometer, a considerable deflection was observed ; there was a feebler one 3 or 4 minutes after, and even as long as 20 or 30 minutes afterwards.

When the insulated galvanometer was permanently connected with one end of the wire, and then the free end of the galvanometer wire joined to the pole of the battery, a rush of electricity through the galvanometer into the wire was perceived. The deflection speedily diminished and the needle ultimately came to rest at zero. When the galvanometer was detached from the battery and put to earth, the electricity flowed as rapidly out of the wire, and the needle was momentarily deflected in the opposite direction.

These phenomena are not difficult to explain. The wire with its thin insulating coating of gutta-percha becomes statically charged with electricity from the battery like a Leyden jar. The coating of gutta-percha through which the inductive action takes place is comparatively thin, and the extent of the coatings (copper wire on the one side, and the conducting sheath in contact with water on the other side of the dielectric gutta-percha) is very great. The surface of the copper wire amounted to 8300 square feet and that of the outside coating to four times as much. The potential can only be as great as that of the battery, but, from the enormous surface, the capacity, and therefore the quantity (760), is very great. Thus the wires, after being detached from the battery, showed all the actions of a powerful electric battery. These effects take place, but to a less extent, with wires in air ; the external coating is here the earth, which is so distant that induction and charge are very small, more especially in the long lines.

Hence the difficulty in submarine telegraphy. The electricity which enters the insulating wire must first charge the large Leyden jar which it constitutes, and only after this has happened can the current reach the distant end of the circuit. The current begins later at the distant end, and ceases later. The electricity is not projected like the bullet from a gun, but rather resembles a quantity of water flowing from a large reservoir into a canal in connection with large basins which it has to fill as well as the canal itself. If the electric currents follow too rapidly, an uninterrupted current will appear at the other end, which indicates small differences in strength, but not with sufficient clearness differences in duration or direction. Hence in submarine wires the signals must be slower than in air wires to obtain clear indications. The retardation depends not only on the length (and therefore capacity) of the cable, but also on its self-induction, which will be explained later (967).

By the use of alternating currents sent by a special form of key—that is, of currents which are alternately positive and negative (985)—these

disturbing influences may be materially lessened, and communication be accelerated and made more certain, but they can never be entirely obviated.

The first submarine telegraph cable (figs. 920, 921) was laid between Dover and Cape Grisnez in 1851, and this was followed during the next ten years by the laying of submarine cables of greater length, which were short, however, in comparison with more recent developments. The successful telegraphic bridging of the Atlantic was effected in 1866, after three unsuccessful attempts in 1857, 1858, and 1865. At the present day there are about 200,000 miles of submarine telegraph cable. The greatest undertaking of the kind hitherto attempted is the Pacific cable now being constructed between Vancouver and Australia, *via* Fanning Island, Fiji, and Norfolk Island.

917. **Siphon recorder.**—Lord Kelvin invented an extremely ingenious instrument called the *siphon recorder*, by which the very feeble signals transmitted through long lengths of submarine cable are observed and also recorded. In principle it is a suspended coil galvanometer (896). It must be noted, however, that suspended coil galvanometers for ordinary electric work have only comparatively recently come into use.

A light rectangular coil of fine wire s (fig. 929), connected with the line wire by the screws p and q , hangs by a bifilar suspension between the two poles of a powerful electromagnet AB , so that its plane is parallel to the lines of force between the poles. The space inside the coil is occupied by a mass of soft iron, f , by which the strength of the field is greatly increased. When a current is passed this coil tends to place itself perpendicular to the lines of force, and is deflected either to the right or the left according to the direction of the current; its movements are almost dead-beat (963), as the damping is considerable.

A very light capillary tube c dips with its short end in a reservoir of ink, while the other end is in front of a paper ribbon which is moved along at a uniform rate like the ribbon in a Morse's recorder. By the action of a light tapper the ink spurts out in a continuous series of fine drops against the paper, marking on it a straight line so long as no current passes in the coil. The siphon is, however, connected by a system of silk threads with the coil, and according as this is deflected to the right or the left the end of the siphon is deflected too, and traces a wavy line (fig. 930) on the paper, which represents deflections right or left of the central line, that are, in short, the Morse signals (914).

918. **Duplex telegraphy.**—By this is meant a system of telegraphy by which messages may be simultaneously sent in opposite directions on one

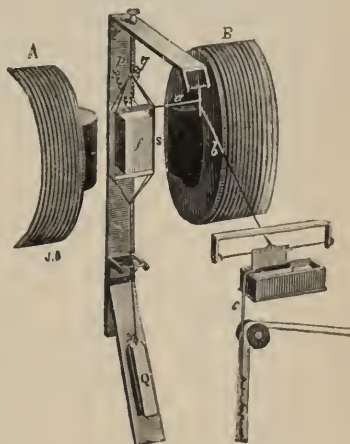

Fig. 929

and the same wire, whereby the working capacity of a line is practically doubled.

Several plans have been devised for accomplishing this very important improvement ; no more can here be attempted than to give a general account of the principle of the method in one or two cases.

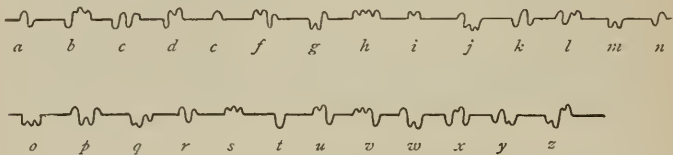

Fig. 930

Let *m* (fig. 931) represent the electromagnet of a Morse's instrument which is wound round with two equal coils in opposite directions ; these coils are represented by the full and dotted lines, and one of them, which may be called the *line coil*, is joined to the line LL', which connects the two stations. The other coil, that represented by the dotted line, which may be called the

equating coil, is in connection with the earth at E through an adjustable resistance, or *artificial line*, R. By this means the resistance of the branch aKE may be made equal to that of the branch aLL'a'. The battery *b* has one pole to earth at E, and the

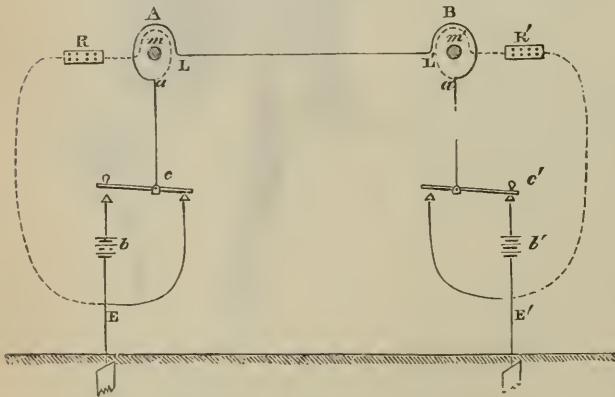

Fig. 931

other pole, by a Morse key, *c*, can be connected at *a*, where the two oppositely wound coils bifurcate. The back contact of the key is also connected with earth.

The station at B is arranged in a similar manner, as is represented by corresponding dashed letters.

Now, when B depresses his key and sends a current into the line, inasmuch as the electromagnet of his instrument is wound with equal coils in opposite directions, the armature is not attracted, for the core is not magnetised because the currents in the two coils counteract one another. Thus, although a current passes from B, there is no indication of it by his own instrument—a condition essential in all systems of duplex telegraphy.

But with regard to the effect on A, there are two cases, according as he is or is not sending a message at the same time. If A's key is not down,

then the current will circulate round the core of the electromagnet and will reach the earth by the path $LacE$; the core will therefore become magnetised, the armature attracted, and a signal produced in the ordinary way.

If, however, at the moment at which B has his key down, A also depresses his, then it will be seen that, as the batteries bb' are exactly alike, their electromotive forces neutralise one another, and no current passes in the line $aLL'a'$: it is, as it were, blocked. But though no current passes in the line coil, a current does pass at each station to earth, through the equating coil, the current in which, being no longer counterbalanced by any opposite current in the line coil, magnetises the core of the electromagnet, which thus attracts the armature and produces a signal.

We have here supposed that A and B both send, for instance, the same currents to line: the final effect is not different if they send opposite currents at the same time. For then the current in the line LL' is doubled. More electricity flows to line from each station through the line coil being no longer balanced by the equating coil; the current of the line coil preponderates and then works the electromagnet.

Hence each station, so to speak, produces the signal which the other one wishes to send.

Another method is based on the principle of Wheatstone's bridge (923). At each station is a battery P (fig. 932), one pole of which is to earth while the other is connected with the key M .

The wire from M is connected at A with the two branches AB and AC , a galvanometer or other receiving instrument being introduced between B and C . The branch AB goes to line and AC to earth. There are exactly corresponding parts at the other station. Now, from the principle of the bridge, the resistances AB and AC may be adjusted in such a manner that the potentials at the points B and C are equal when the key is depressed and the current sent; accordingly, no current passes in the bridge, and the galvanometer is at rest; but the current from A passing to line bifurcates at B' , a portion traversing the galvanometer and going to earth; hence a signal is received at that station.

Other methods of duplex telegraphy are based on the principle of leakage; but for these, as well as for quadruplex telegraphy, special manuals must be consulted. The present speed of transatlantic telegraphy is about twenty words a minute, and there are twelve duplexed cables having, therefore, a carrying capacity of 500 words a minute.

919. **Bain's electrochemical telegraph.**—If a strip of paper is soaked in a solution of potassium ferrocyanide and is placed on a metal surface connected with the negative pole of a battery, on touching the paper with a steel pointer connected with the positive pole, a blue mark due to the formation of Prussian blue will be formed about the iron, so long as the current passes. The first telegraph based on this principle was invented by Bain. The alphabet is the same as Morse's, but the despatch is first composed at

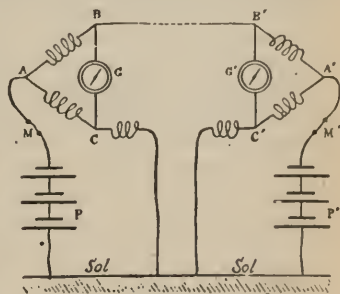

Fig. 932

the departure station on a long strip of ordinary paper. The paper is perforated successively by small round and elongated holes, which correspond respectively to the dots and dashes. The strip so prepared is interposed between a small metal wheel and a metal spring, both forming part of the circuit. The wheel, in turning, carries with it the paper strip, all parts of which pass successively between the wheel and the plate. If the strip were not perforated, it would, not being a conductor, constantly offer a resistance to the passage of a current; but, in consequence of the holes, every time one of them passes, there is contact between the wheel and the plate. Thus the current works the relay of the station to which it is sent, and traces in blue, on a paper disc, impregnated with potassium ferrocyanide, the same series of points and marks as those on the perforated paper.

920. **Earth currents.**—In long telegraph circuits more or less powerful currents are produced, even when the battery is not at work. This arises from a difference of potential being established in the earth at the two places between which the communication is established. These currents are sometimes in one direction and sometimes in another, and are at times so powerful and irregular as quite to interfere with the working of the lines. Lines running NE and SW are most frequently affected; lines running NW and SE are less so, and the currents are far weaker. Their strength often amounts to as much as 40 milliamperes (849), which is a stronger current than is required for working ordinary telegraph instruments.

These currents do not seem to be due to atmospheric electricity, but they are certainly intimately connected with magnetic storms (738).

921. **Writing telegraphs. Telautograph.**—Many systems have been devised for transmitting by electricity the actual handwriting of the person who sends the message. The following gives a general idea of the principle of that invented by Mr. Cowper :—

Two line wires are required, which are severally connected at the receiving station with two galvanometers, whose coils are at right angles to each other. At the sending station is a vertical pencil with two light rods, jointed to it at right angles to each other. One of these contact rods guides a contact piece which is connected by a wire with one pole of a battery, the other pole of which is to earth. This contact piece slides over the edges of a series of contact plates insulated from each other, between each of which and the next a special resistance is interposed, and the last of the contact plates is connected with one line wire. The other contact piece slides over a second series of such plates connected with the other line wire.

Let us consider one contact piece alone; as it moves over the contact plates in one direction or the other, it brings less or more resistance into the circuit, and thereby alters the strength of the current. The effect of this is that the needle of the corresponding galvanometer is less or more deflected. Now the end of this needle is connected by a light thread with a receiving pen, which consists of a glass tube terminating in a very small orifice, and containing ink. An oscillation of the needle would produce an up and down motion of the pen, and if simultaneously a band of paper passed under the pen, being moved regularly by clockwork, there would be produced on it a series of up and down strokes. A corresponding effect would be produced by the action of the needle of the other galvano-

meter, except that its strokes would be backwards and forwards instead of up and down.

Now the action of the writing pen is that it varies simultaneously the strengths of the two currents, and they produce a motion of the receiving pen which is compounded of the two movements described above, and which is an exact reproduction, on a smaller scale, of the original motion. The following line is a facsimile.

A facsimile of a handwritten line in cursive script. The text reads "Royal Society Burlington House". The line starts with a horizontal stroke on the left, followed by the words "Royal Society" and "Burlington House" written in a fluid, connected cursive hand.

Fig. 933

Both the paper written in pencil at the sending station and that written in ink at the receiving station move along as the writing proceeds, and the messages have only to be cut off from time to time.

Experiments made with this instrument show that it will write through resistances equal to 36 miles of telegraph wire.

In Mr. Foster Ritchie's *Telautograph* two wires also are needed to connect the transmitting and receiving instruments; these are connected as a single loop earthed at each end, thus providing three distinct circuits, since currents can be sent through either of the wires to return by earth, or can be sent by one wire to return by the other. The pencil with which the operator writes is connected to two sets of levers which actuate the sliding contacts of two rheostats (857); these rheostats are connected one in series with each of the two lines. As the resistances are varied by the motion of the sliding-contacts corresponding to the motion of the pencil, the currents in the two lines will vary. These currents pass through and deflect the moving coils of two d'Arsonval galvanometers (896) in the receiving instrument, which are connected by two sets of levers to the receiving pen. Thus the position of the pen is controlled by the deflections of the two galvanometers, which are in their turn dependent on the position of the transmitting pencil. The pen will, therefore, exactly follow in its motions the movements of the pencil, and will consequently repeat on the paper at the receiving end the words written on that at the transmitting end. There is an ingenious arrangement by which the receiving pen only makes marks on the paper when the transmitting pencil is pressed down on the writing-table. The message can be written at the ordinary speed of handwriting. There is no difficulty in writing, in spite of the pencil being attached to the rheostats, and having to move them. Moreover, as long as the paper is not shifted the writer can go back and make alterations and additions with perfect accuracy.

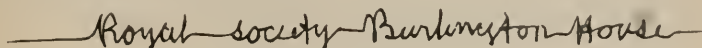
CHAPTER VIII

ELECTRIC MEASUREMENTS

922. **Current.**—Several types of instruments for measuring current have already been described (837-843, 867, 896, 898, 903). In some of these the relation between the indication of the instrument and the current flowing through it follows a known law, as in the tangent and sine galvanometers and Siemens' electro-dynamometer. In others, for example in most ammeters, there is no simple connection between current and deflection, and the scale has to be graduated empirically. In reflecting galvanometers the maximum angular motion of the needle which can be observed does not exceed five or six degrees, and the movement of the spot of light may be taken as directly proportional to the current producing it.

923. **Resistance.**—The most convenient method of ascertaining experimentally the ratio between the resistance of two conductors is by a method known as that of *Wheatstone's bridge*, the general principle of which may be thus stated :—

Suppose two points, A and C (fig. 934), to be connected to the positive and negative poles respectively of a voltaic cell, and these points to be joined by

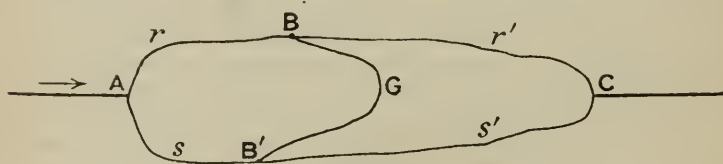

Fig. 934

two wires, ABC, AB'C. The current arriving at A flows through the two branches in strengths inversely proportional to their resistances (853). The potential of any point B in ABC is intermediate between those of A and C, and there must be some point B' in the lower branch, which has the same potential as B, and if these points are joined by a wire, no current will flow through it. If B' is moved a little towards C, B will be at a higher potential than B', and the needle of a galvanometer inserted at G, between B and B', will be deflected, say, to the right; contrariwise, if B' moves towards A, the deflection will be to the left, B' being now at a higher potential than B. If the galvanometer needle is not deflected, B and B' are at the same potential, and this being so, it may be proved that

$$r : r' = s : s',$$

where r , r' , s , s' , are the resistances respectively of AB, BC, AB', B'C.

Hence $r' = r \frac{s'}{s}$, and if r is a standard resistance, and the ratio of s' to s is known, the value of the unknown resistance r' is determined.

To prove the relation just given, let MN , NO , MN' and $N'O'$ (fig. 935) be taken in the same straight line, proportional respectively to the several resistances r , r' , s , s' ; and let MP be drawn at right angles to $O'MO$ of a length proportional to the difference of potential between the points A and C . Then the straight lines PO and PO' represent the slope (or rate of

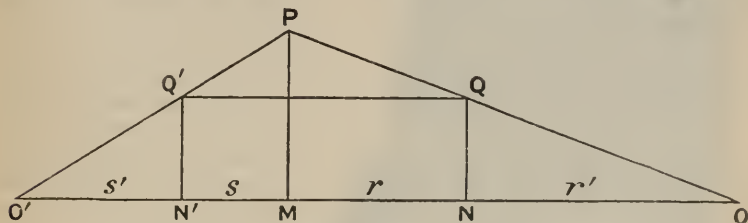

Fig. 935

fall) of potential from A to C along the two branches respectively. If NQ is drawn perpendicular to MO , meeting PO in Q , NQ represents the difference of potential between B and C ; and the point N' (corresponding to B' in the previous figure), where the potential is the same as at N , will be found by drawing QQ' parallel to OO' , and letting fall from Q' the perpendicular $Q'N'$ upon $O'M$. The geometry of the figure gives obviously,

$$\frac{r'}{r + r'} = \frac{NQ}{MP} \quad \text{and} \quad \frac{s'}{s + s'} = \frac{N'Q'}{MP},$$

and therefore since $NQ = N'Q'$

$$\frac{r}{r'} = \frac{s}{s'}$$

A convenient form of Wheatstone's bridge, and one well adapted for purposes of instruction, is that represented in fig. 936. It is called the *metre wire bridge*. It consists of a long mahogany board, on which is fixed

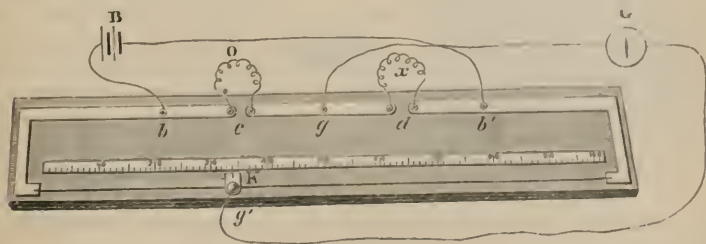

Fig. 936

a thick copper band, which practically offers no resistance. To the ends of this band is soldered a straight platinum or german-silver wire, near which is a scale divided into 100 parts. At c and d are breaks in the copper

band, provided with binding screws, in which are introduced the resistances to be compared, O and x . The wires, from a cell of small E.M.F., so as not to introduce heating effects, are connected with the binding screws b and b' . Another wire connects the binding screw g and one terminal of a sensitive galvanometer, the other terminal of which is connected with a sliding spring contact-key g' , so constructed that when the knob is depressed

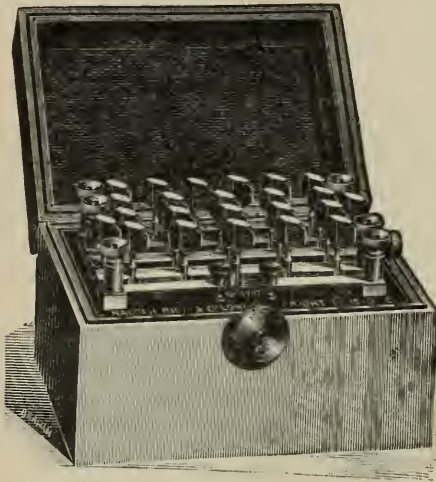

Fig. 937

or 1000 ohms, which correspond to the two parts of the straight wire in the metre bridge; from D to B is a set of standard coils, R , the individual resistance ranging from 1 to 4000, and the total resistance being about 10,000 ohms. The box is provided with two contact

a knife-edge makes contact with the wire. The resistances to be compared having been introduced at c and d , the position on the metre wire is found by trial, at which, when the key is depressed, the needle of the galvanometer is not deflected. When this is found, for instance, at 34, the resistance of O : the resistance of $x = 34 : 66$.

Another form of Wheatstone's bridge, known as the *Post Office Pattern*, is illustrated in fig. 937; fig. 938 gives a plan of the instrument. AC and AD are two resistances each of 10 or 100

keys, K, K , that on the right for the battery circuit, that on the left for the galvanometer circuit. K on the right, when depressed, connects together the two points, A, A , by means of a wire underneath the ebonite top of the box, indicated in fig. 938 by a dotted line. Similarly the left-hand key connects D and D together. The battery is introduced between A and B , the galvanometer between C

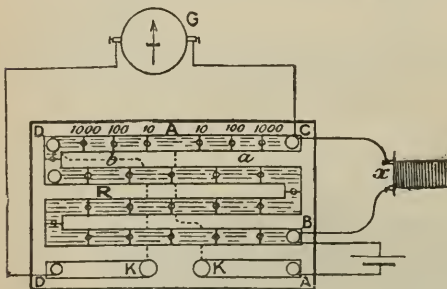

Fig. 938

and D , while the coil, whose resistance is to be measured, is connected by wires to the terminals C and B .

The letters a, b, x, R in fig. 938, representing corresponding resistances, it will be seen that the bridge is *balanced*—that is, no current flows through the galvanometer, when $x/R = a/b$.

To determine the value of the unknown resistance, x , we proceed as

follows:—(1) Unplug 10 and 10 in the branches a and b , that is, make $a = b = 10$, and leave all the rest of the plugs in their places, so that $R = 0$. Now press the keys K, K , first the battery key on the right, then the galvanometer key on the left. The needle will be deflected, say, to the right. Now, unplug a large resistance, or 'infinity,' in R ; the needle will be deflected to the left. Gradually reduce the resistance in R , and suppose that, when $R = 23$ the deflection is to the right, and when $R = 24$ it is to the left. Then the unknown resistance is something between 23 and 24; and so long as $a/b = 10/10$ we cannot approximate closer to the real value of x , since the smallest resistance in the box is 1 ohm.

(2) Let $a = 10, b = 100$; then $x/R = 10/100$ and $x = R/10$, and therefore R must be something between 230 and 240. Suppose we find that the needle moves to the right when $R = 245$, and to the left when $R = 246$; it follows that x is between 24.5 and 24.6 ohms.

(3) Make $b = 1000, a$ being still 10; then $x = R/100$, and R must be between 2450 and 2460. If there is practically no deflection on depressing the keys when R is 2457, $x = 24.57$ ohms. It will thus be seen that we can by this arrangement measure a resistance whose value does not exceed 100 ohms to the hundredth of an ohm. If the resistance to be determined is very large, say 200,000 ohms, we can measure it (though with no great accuracy) by making $a = 1000$ and $b = 10$, so that $x = 100R$, and R will be 2000 ohms. This bridge, in fact, enables us to measure a resistance whose value is anything between .01 ohm and 1,000,000 ohms. But for very high or very low resistances other methods of determination are generally employed.

924. **Resistance of a galvanometer.**—The resistance of a galvanometer may be determined by Wheatstone's bridge in the ordinary way, introducing it in the place of x in fig. 936 or fig. 938. A modification of the bridge method, however, due to Lord Kelvin, enables the resistance to be measured by means of the deflection of the instrument itself.

Thus let the galvanometer whose resistance G is required be inserted at the gap d of the Wheatstone's bridge (fig. 936), O being a known resistance. Join gg' by a simple wire and let the other connections be as before. The galvanometer needle will be deflected, and the deflection will generally alter when K is depressed. Now let K be moved until a position has been found for it, such that the deflection is the same whether K is depressed or not. We then have $G : O =$ the ratio in which K divides the wire.

925. **Difference of potential.**—The difference of potential between two points may be measured by the quadrant electrometer, or the electrostatic voltmeter (798). Large differences of potential may also be measured by Cardew's voltmeter (867), or other hot-wire instrument. The voltmeter, however, in most common use is essentially a sensitive galvanometer, having either a high resistance of its own, or an independent high resistance in series with it. Suppose, for example, it is desired to determine the difference of potential, ϵ , between the ends A, B , of a coil through which a current is flowing. Connect A and B to the terminals of the galvanometer, so that between A and B we have a divided circuit. If R is the resistance of the galvanometer (or galvanometer and associated high resistance coil), and r the resistance of the coil AB , the current flowing through the

galvanometer is $\frac{r}{R}$ of that flowing through the coil (853), and if R is very large in comparison with r , we shall make no appreciable error in assuming that the presence of the galvanometer does not affect the value of e , the D.P. that we wish to measure. Then $e = cR$, where c is the current flowing through the galvanometer, and is directly read off if the galvanometer is a direct-reading voltmeter, or, if an ordinary galvanometer, is obtained by multiplying the deflection by the reduction factor (841). The Weston voltmeter is constructed on the same principle as the ammeter already described (898). It has a resistance of ten or fifteen thousand ohms.

The electromotive force of a cell, that is, the D.P. between its poles on *open* circuit, may be measured by connecting it in circuit with a voltmeter. It is true that in this case the circuit is not open, but if the resistance of the voltmeter is large in comparison with that of the cell, the D.P. between the poles is practically the same whether the circuit is open or closed. This will be made evident by an examination of fig. 835, for if r/R is very small, HD is practically equal to MA .

926. **Determination of resistance by measuring C and e .**—There are many instances in which the resistance of a conductor cannot be conveniently determined by Wheatstone's bridge. In these cases the method of measurement usually adopted is to connect the resistance to be measured in circuit with a suitable battery and an ammeter, and to note the current, C , at the same time that the D.P., e , between the ends of the conductor, is measured by a voltmeter (925). The resistance required is then e/C . This method would be adopted for the measurement of the resistance of a short length of thick wire or cable. A powerful current is passed through the cable, and the D.P. between its ends measured by a sensitive voltmeter. Since $e = CR$, and R is assumed to be very small, it is necessary for C to be large in order that a measurable value of e may be obtained.

The resistance of the carbon filament of a glow lamp cannot be measured by Wheatstone's bridge when the lamp is glowing, but is easily determined by the above method. For example, if C , the current flowing through the lamp, is .5 ampere, and e , the difference of potential at its terminals, is 110 volts, $R = 220$ ohms. The resistance of the lamp when cold, which could be readily measured by the method of Wheatstone's bridge, would be about 400 ohms.

927. **Internal resistance of a cell.**—The following is a method of determining the internal resistance of a cell. A circuit is formed containing the cell, a box of resistance coils, and a galvanometer, and the resistance adjusted so that a convenient deflection of the needle is obtained. The cell is now arranged in parallel with another exactly similar cell, whereby the internal resistance is halved, but the current is kept constant by introducing additional resistance, R_1 , into the circuit. Let C be the current, E the E.M.F., x the internal resistance of each cell, and R the rest of the resistance, then $C = \frac{E}{R+x} = \frac{E}{R+R_1+\frac{x}{2}}$, and $x = 2R_1$.

Another method is that due to Sir H. Mance. The cell whose internal resistance is to be determined is placed in one of the arms of a Wheatstone's

bridge as at fig. 936, a resistance box being placed in the other—for example, the cell in the gap d , and the box of coils at c . The galvanometer is connected to b and b' , and a simple wire connects g and g' ; by trial a position is found for the sliding contact such that when the key is depressed no alteration is produced in the deflection of the galvanometer. When this is found, the ordinary conditions of the bridge hold—that is, the cross products of the resistances are equal.

If the resistance of the cell or battery is very small, a good method of determining it is as follows:—

Measure by a voltmeter the E.M.F. (E) of the cell, that is, the D.P. between its terminals when it is otherwise on open circuit; connect the poles by an ammeter and again note the D.P. (e) between the terminals, and also the current. Then since $C = \frac{E}{R+x} = \frac{e}{R}$, it follows that $x = \frac{E-e}{C}$.

928. **Ohmmeter.**—The resistance of a conductor $= \frac{e}{C}$, where C is the current flowing through the conductor, and e the difference of potential at its ends. The ohmmeter is an ingenious piece of apparatus by which the ratio e/C may be directly obtained. Its principle will be understood from what follows:—

We have already seen (724) that when a compass needle is deflected from the magnetic meridian by an angle θ , due to the action of a transverse field F , $F = H \tan \theta$.

In fig. 939, AA_1 are two parallel circular coils of low resistance connected together like the coils of a Helmholtz galvanometer (837); BB_1

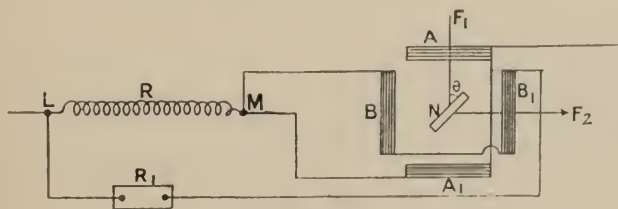

Fig. 939

are two similar coils, of high resistance, with their planes at right angles to those of AA_1 . N is a small magnetic needle pivoted at the centre of these coils, the action of the earth's magnetism on which is neutralised by a weak bar-magnet suitably placed. A current flowing through the coils AA_1 , will give rise to a magnetic field, the direction of which at N will be along NF_1 . Similarly the field at N due to a current in the coils BB_1 , will be along NF_2 . If the strengths of these fields are denoted by F_1 , F_2 , and if θ is the angle which the axis of the needle makes with NF_1 , then, from the relation given above, $\tan \theta = \frac{F_2}{F_1}$. Now let LM be the conductor whose resistance,

R , is to be measured, and let it be joined in series with the low-resistance coils AA_1 , while fine wires connect its extremities with the terminals of the

high-resistance coils BB_1 . The magnetic forces F_1, F_2 , are proportional to the currents C, c , flowing through the coils, and c the current through BB_1 , is proportional to e , the D.P. at the ends of R. Hence $\frac{e}{C} = k \frac{F_2}{F_1} = k \tan \theta$, where k is a constant, and thus the required resistance is proportional to the tangent of the deflection. The value of k is determined by noting the value of θ when R has a *known* value.

929. Comparison of electromotive forces. **Wheatstone's method. Wiedemann's (sum and difference) method.**—We may compare the E.M.F.s of two cells by the aid of a galvanometer (tangent or sensitive reflecting) and a box of resistance coils. Let E_1, E_2 be the E.M.F.s of the two cells.

(1) Join up the first cell, E_1 , in circuit with galvanometer and resistance box, and adjust the resistance until a suitable deflection has been obtained (say 60° in the case of a tangent galvanometer, or 200 scale divisions with a reflecting instrument). Let R be the *total* resistance in the circuit. Now introduce more resistance, a , from the box of coils, so that the deflection is reduced to, say, 30° or 100 divisions. Let C_1, C_2 be the currents in the two cases.

The second cell, E_2 , is now substituted for E_1 , and the resistance modified until the current is C_1 , the total resistance being R_2 ; then further resistance, b , is introduced until the current is reduced to C_2 .

By Ohm's law

$$\begin{aligned} C_1 &= \frac{E_1}{R_1} & C_1 &= \frac{E_2}{R_2} \\ C_2 &= \frac{E_1}{R_1 + a} & C_2 &= \frac{E_2}{R_2 + b} \end{aligned}$$

from which we have $\frac{E_1}{E_2} = \frac{a}{b}$.

This is Wheatstone's method.

(2) In Wiedemann's method the two cells are introduced together into a circuit, their E.M.F.s being similarly directed and a suitable deflection obtained by adjusting the resistance in the circuit. One of the cells is then reversed so that the E.M.F.s may oppose each other, and the deflection noted, the resistance in the circuit not being altered. If R is this resistance, r_1, r_2 the resistances of the cells, and C_1, C_2 the currents in the two cases,

$$\begin{aligned} C_1 &= \frac{E_1 + E_2}{R + r_1 + r_2}, & C_2 &= \frac{E_1 - E_2}{R + r_1 + r_2}, \\ \therefore \frac{C_1}{C_2} &= \frac{E_1 + E_2}{E_1 - E_2}, & \text{and } \frac{E_1}{E_2} &= \frac{C_1 + C_2}{C_1 - C_2} \\ &= \frac{d_1 + d_2}{d_1 - d_2}, & \text{where } d_1, d_2 &\text{ are the deflections of the spot of light} \\ & & &\text{(reflecting galvanometer),} \end{aligned}$$

or = $\frac{\tan \alpha_1 + \tan \alpha_2}{\tan \alpha_1 - \tan \alpha_2}$, in the case of a tangent galvanometer.

(3) The electromotive force of a cell, and generally the difference of potential between any two points of a circuit conveying a current, may be determined by charging a condenser from the poles of the cell or the points

in question, and discharging it through a ballistic galvanometer. Suppose the throw of the needle due to the discharge to be D . Now charge the condenser from a Latimer Clark cell, the E.M.F. of which at 15° C. is 1.435 volts (827), discharge through the galvanometer and let the throw be d . Then, the E.M.F. or potential difference required is $\frac{D}{d} \times 1.435$. If in the second experiment the galvanometer is shunted (854) so that only $1/n$ of the discharge passes through it, the difference of potential is $\frac{nD}{d} \times 1.435$.

930. **Quantity of electricity.**—The strength of an electric current in a conductor is the quantity of electricity which passes through a cross-section of the conductor in the unit time, so that if Q represent quantity, and t the time during which the current C flows, $Q = Ct$. If the current is steady, the quantity of electricity which has passed through a circuit in a certain time is given by a galvanometer, but the case is different if C is variable. We shall see in the chapter on Electrolysis how a quantity of electricity may be measured by the amount of chemical decomposition it is capable of effecting. A ballistic galvanometer (843) is used to measure the quantity of electricity with which a condenser is charged, or the quantity which has traversed a circuit in consequence of induced electromotive force.

The practical unit of electric quantity is a *coulomb*. It is the quantity due to the passage of a current of 1 ampere for 1 second, or of $\frac{1}{2}$ ampere for 2 seconds, and so on.

931. **Electric capacity.**—The capacity of a conductor is measured by the quantity of electricity required to raise its potential by unity, the potential of surrounding bodies being supposed to remain unchanged. The capacity of a condenser is the quantity of electricity which will raise by unity the difference of potential between its coatings. If one coating of a condenser receives a charge of 1 coulomb, and the D.P. between its coatings is increased by 1 volt, the capacity is 1 *farad*. A farad is 10^9 C.G.S. units of capacity. The farad is far too large a unit for practical use; thus the capacity of the earth regarded as a spherical conductor is only $.000636$ of a farad, and even that of the sun does not reach a farad. Accordingly, the technical or working unit of capacity is the millionth part of a farad, or a *microfarad*. It is 10^{-15} absolute units. A Leyden jar with a total coated surface of a square metre, the glass of which is 1 mm. thick, has a capacity of $\frac{1}{3}$ of a microfarad, assuming the specific inductive capacity of the glass to be 3. The capacity of an ordinary submarine cable may be taken at about $\frac{1}{4}$ of a microfarad per nautical mile of 1829 metres (2000 yards). A sphere 9 kilometres in radius has a capacity of a microfarad.

The practical standards consist of circular or square sheets of tinfoil with projecting tongues, a and a' (fig. 940), fastened on thin sheets of mica. Between each pair of such coated sheets is placed an uncoated one of mica, the two sets of tongues being severally connected with each other, and thus the coatings represent the coated surfaces of a condenser, the area of the coated surface of which is the

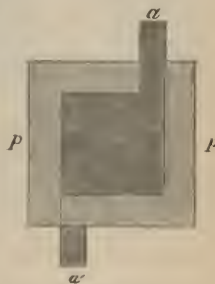

Fig. 940

sum of the areas of the tinfoil sheets. The whole is tightly compressed and enclosed in a box.

The capacities, C and C' , of two condensers may be compared, by an arrangement (fig. 941) resembling that of Wheatstone's bridge, by con-

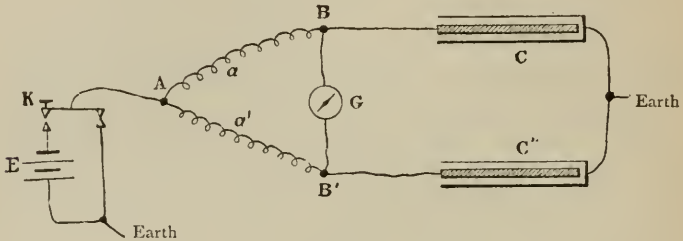

Fig. 941

necting the inner coatings at B and B' respectively (fig. 941), their outer coatings being put to earth. The two resistances a and a' are adjusted, so that by pressing or releasing the key K , which puts the battery E in connection with A , no current is shown in the galvanometer.

The condition of equilibrium is that the two points of the bridge B and B' are at the same potential—that is to say, at a given time the charges Q and Q_1 , are proportional to the capacities C and C' ; as these charges are proportional to the currents which produce them, and as these latter again are inversely as the resistances, we have the proportion

$$C : C' = a' : a.$$

The capacities of two condensers may also be compared by means of a ballistic galvanometer (843) as follows:—Each condenser is connected with a cell and ballistic galvanometer by a switch with a movable tongue. When the tongue is over on one side, the condenser is charged by the cell, the difference of potential between its coatings being the E.M.F. (E) of the cell. When the tongue is rapidly thrown over to the other side the condenser is discharged through the galvanometer. The throw of the needle measures the charge of the condenser. Since $Q = EC$ (760), it follows that if C, C' are the capacities of the two condensers, $C/C' = Q/Q' = d/d'$, where d, d' are the throws of the galvanometer needle in the two cases.

932. **Electric resistance thermometer.**—This instrument, which is adapted for the measurement of temperatures between -200° and $+1100^\circ$ C., depends on the change in the electric resistance of platinum wire with temperature. If the temperature coefficient, σ (851), of pure platinum is known, and the resistance, R_0, R_t , of a coil of platinum is determined at 0° and at t° , the temperature t is given by the formula $t = \frac{R_t - R_0}{R_0 \sigma}$.

One form of Callendar's platinum thermometer is shown in fig. 942. Fine wire of pure platinum is wound on a strip of mica, B , which is enclosed in a porcelain tube, D , the ends of the wire being connected to thick platinum leads, which terminate at the screws P_1, P_2 by which the coil is

connected with the ends of the gap d , fig. 936, of a Wheatstone bridge, and its resistance measured when cold, and again when the tube is placed in the furnace whose temperature is required. To obviate error due to change of resistance of the thick platinum leads, a compensating device is introduced which consists of a platinum wire, A , of the same length and thickness as the platinum leads. This is inclosed in the tube by the side of the leads, its terminals being at C_1C_2 . Hence its resistance will be the same as that of the leads, since their temperatures are always the same. This compensating wire is introduced, along with the balancing resistance, O , into the gap c , fig. 936, the copper wire leads connecting P_1P_2 and C_1C_2 to the bridge being exactly alike. If the key K is kept at the graduation 50 on the metre scale and a balance obtained by varying O , the resistance of O is exactly the same as that of the fine platinum wire.

If the resistance of the coil at 0° has been also measured, the temperature t is deduced from the above formula.

The same principle has been applied by Professor Langley to the invention of an instrument called the *bolometer*, or *actinic balance*, for measuring radiant heat. The characteristic part of such a balance is a resistance which for a great surface has a very small mass. In the latest improved form this consists of a grating of platinum, the bars of which are 32 mm. in length by 1.5 mm. in breadth, and are 1 mm. apart (fig. 943). The thickness is about 1 micron, and this extraordinary tenuity is attained by a process based on that by which Wollaston obtained fine wire. Such a grating is fixed in a slate frame (fig. 944); two of them being placed in the two arms of a Wheatstone's bridge, one of them is exposed

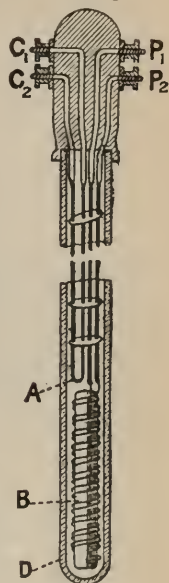

Fig. 942
From 'Watson's
Physics'



Fig. 943

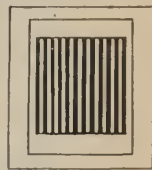

Fig. 944

to the action of radiant heat. The sensitiveness is comparable with that of the most sensitive form of thermo-electric apparatus, *e.g.* that of Mr. Boys (873). It has been used by the inventor to measure the distribution of heat in the solar spectrum. By its means he has been able to map the dark heat of the spectrum (436), and to extend it far beyond the limits which were previously known. It has also been used in the investigation of electric vibrations (1003). By recent improvements Professor Langley has been able to increase the sensitiveness of the apparatus tenfold.

CHAPTER IX

ELECTROLYSIS

WHEN strips of platinum foil connected with the poles of a battery are immersed in a conducting liquid, the latter is decomposed, one of its constituents appearing at the place where the current enters the liquid, the other at the place where it leaves.

933. **Decomposition of water.**—The first decomposition effected by electricity was that of water, in 1800, by Carlisle and Nicholson, by means of a voltaic pile. Water is rapidly decomposed by a battery of 5 or 6 volts; the apparatus (fig. 945) is convenient for the purpose. It consists of a glass vessel fixed on a wooden base. In the bottom of the vessel two platinum plates called electrodes, *p* and *n*, are fitted, communicating by means of copper wires with the binding screws. The vessel is filled with water to which some sulphuric acid has been added to increase its conductivity, for pure water is a very imperfect conductor (852); two glass tubes filled with the acidulated water are inverted over the electrodes, and on interposing the apparatus in the circuit of a battery, decomposition is rapidly set up, and gas bubbles rise from the surface of each plate. The volume of gas liberated at the negative electrode is about double that at the positive, and on examination

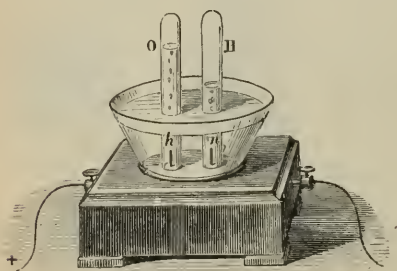

Fig. 945

the former gas is found to be hydrogen and the latter oxygen. This experiment accordingly gives at once the qualitative and quantitative analysis of water. The oxygen thus obtained has the peculiar and penetrating odour observed when an electric machine is worked (809), which is due to ozone. The water contains at the same time peroxide of hydrogen, in producing which some oxygen is consumed. Moreover, oxygen is somewhat more soluble in water

than hydrogen. Owing to these causes the volume of oxygen is less than that required by the composition of water, which is two volumes of hydrogen to one of oxygen. Hence measurements are most exact when the hydrogen alone is determined, and when this is liberated at the surface of a small electrode. This arrangement is called a *water voltameter* (941).

934. **Nomenclature.**—The term *electrolyte* was applied to those liquids which are resolved into their elements by the electric current, by Faraday, to whom the principal discoveries in this subject and the nomenclature are due. *Electrolysis* is the decomposition by the battery; the *electrodes* are the conductors by which the current enters and leaves the electrolyte; the positive electrode, or that by which positive electricity enters, Faraday called the *anode*, and the negative electrode the *kathode*. The products of decomposition are *ions*; *kation*, that which appears at the kathode; and *anion*, that which appears at the anode. The kation is said to be electropositive with regard to the anion, which is relatively electronegative.

Pure water is practically not a conductor of electricity, nor is sulphuric acid; but a solution of sulphuric acid in water is a good conductor. The conductivity increases with the proportion of H_2SO_4 until the density reaches 1.225, after which it diminishes. The solution of highest conductivity has a specific resistance of about 1.1 ohm.

935. **Secondary actions.**—The apparatus represented in fig. 946 consists of a U tube resting on a glass foot. An electric current, produced by three or four Daniell cells, may be passed into any electrolyte contained in the tube by means of electrodes made of sheet platinum, connected by platinum wires with the terminals A and B. Suppose the liquid to be a solution of sodium sulphate in water, and to be coloured with neutral litmus. The action of the current is to split up the sodium sulphate (Na_2SO_4) into sodium (Na_2) and sulphion (SO_4). These are the ions. By a *secondary* chemical action the sodium combines with water at the moment of its separation, producing soda and hydrogen, according to the equation $\text{Na}_2 + 2\text{H}_2\text{O} = 2\text{NHO} + \text{H}_2$. Similarly the anion SO_4 combines with the water of the solution, giving rise to sulphuric acid and oxygen, $\text{SO}_4 + \text{H}_2\text{O} = \text{H}_2\text{SO}_4 + \text{O}$. What is seen, therefore, a short time after the circuit is completed, is the evolution of gas at the two electrodes, oxygen at the anode, and hydrogen at the kathode, while at the same time the liquid becomes red at the anode and blue at the kathode.

If the tube contains neutral solution of copper sulphate (CuSO_4) in water, the ions are copper (Cu) and sulphion (SO_4). The copper is deposited in the metallic state on the platinum kathode, while at the anode oxygen bubbles appear and the solution becomes acid. If the electrodes are made of copper instead of platinum no gas appears, for the SO_4 , at the moment of its liberation, attacks the anode copper, reforming copper sulphate, so that what the anode loses in weight the kathode gains, and there is, on the whole, no decomposition.

The decomposition of a solution of hydrochloric acid into its constituents, chlorine and hydrogen, may be shown by means of this apparatus. Carbon electrodes must, however, be substituted for those of platinum, this metal being attacked by the liberated chlorine: a quantity of common salt also must be added to the hydrochloric acid, in order to diminish the solubility of the liberated chlorine. The decomposition of potassium iodide may be



Fig. 946

demonstrated by means of a single Daniell cell. For this purpose a piece of bibulous paper is soaked with a solution of starch, to which potassium iodide has been added. On touching this paper with the electrodes, a blue spot is produced at the anode due to the action of the liberated iodine on the starch.

936. **Davy's experiment.**—By means of the battery, the compound nature of several substances which had previously been considered as elements has been determined. By means of a battery of 250 cells, Davy, shortly after the discovery of the decomposition of water, succeeded in decomposing the alkalis potash and soda, and proved that they were the oxides of the

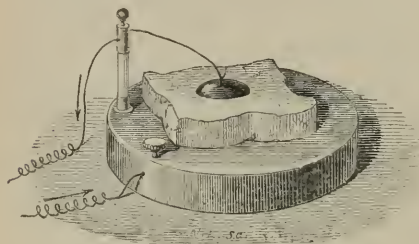

Fig. 947

hitherto unknown metals *potassium* and *sodium*. The decomposition of potash may be demonstrated, with the aid of a battery of 4 to 6 volts, in the following manner: a small cavity is made in a piece of solid caustic potash, which is moistened, and a drop of mercury placed in it (fig. 947). The potash is placed on a piece of platinum connected with the positive pole of the

battery. The mercury is then touched with the negative pole. When the current passes, the potash is decomposed, oxygen is liberated at the positive electrode, while the potassium liberated at the negative electrode amalgamates with the mercury. On distilling this amalgam out of contact with air, the mercury passes off, leaving the potassium.

937. **Grothüss's hypothesis.**—Grothüss gave the following explanation of the chemical decompositions effected by the battery. Adopting the hypothesis that in every binary compound, or body which acts as such, one of the elements is electropositive, and the other electronegative, he assumes that, under the influence of the opposite electricities of the electrodes, there is effected, in the liquid in which they are immersed, a series of successive decompositions and recompositions from one electrode to the other. Hence it is only the elements of the terminal molecules which do not recombine, but, remaining free, appear at the electrodes. Water, for instance, is formed of one atom of oxygen and two atoms of hydrogen; the first gas being electronegative, the second electropositive. Hence when the liquid is traversed by a sufficiently powerful current, the molecule *a*, in contact with the positive electrode, arranges itself as shown in fig. 948—that is, the oxygen is attracted and the hydrogen repelled. The oxygen of this molecule is then given off at the positive electrode, the liberated hydrogen immediately unites with the oxygen of the molecule *b*, the hydrogen of this with the oxygen of the molecule *c*, and so on to the negative electrode, where the last atoms of hydrogen become free and appear on the electrode. The same theory applies to the metallic oxides, to the acids and salts, and explains why in the experiment described in the next article the syrup of violets in the vessel B becomes neither red nor green. The reason why, in the fundamental experiment, the hydrogen is given off at the negative electrode when the circuit is closed will be readily understood from a consideration of this hypothesis.

Clausius objected that, according to this theory, a very great force must be required for overcoming the affinity for each other of the oppositely electrolysed particles of the compound; and that below a certain minimum strength of current no decomposition could occur. Now Buff showed that the action of even the feeblest currents, $\frac{1}{33000}$ of an ampere, for instance, can produce decomposition. Again, when the necessary potential is obtained, it should be sudden and complete; whereas we know that it is proportional to the strength of the current.

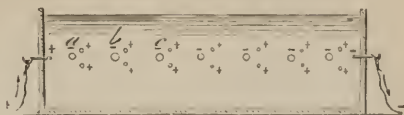

Fig. 948

To overcome this difficulty Clausius applied the theory now generally admitted of the constitution of liquids (294), which was originally propounded by Williamson on the basis of purely chemical considerations. On this theory the particles of a conducting liquid—such as the solution of a salt in water—have not the rigid unalterable condition of a solid body; they are in a perpetual state of separation and reunion, so that we must suppose compound bodies and their elementary constituents to coexist with each other in a liquid.

The theory of Van 't Hoff on the nature of solutions (139), and the experimental researches to which it has led, support the present explanation of electrolytic phenomena, which is due to Arrhenius. In the case of a solution of potassium chloride, KCl, in water, a certain proportion, probably considerable, of the molecules of the salt is in a state of dissociation (394), or *ionisation*, as it is called, which proportion increases with the dilution of the solution; so that along with molecules of the undecomposed salt there are present the free ions potassium and chlorine. These latter are exclusively the carriers of the positive and negative electricity respectively. They may in this respect be regarded as performing a function analogous to that of the pith ball in the convective discharge (786). When electromotive force acts on the solution the ions of chlorine, with their negative charges, tend to move in the direction of the anode, and the ions of potassium, with their positive charges, to the kathode. As they reach the electrodes they give up their charges and are liberated in the free state. Hence the current does not bring about the decomposition, but utilises it, to give definite direction to the particles which are already separated.

These considerations explain why the conductivity of a liquid increases with the temperature (852); for this increases the velocity of the molecules (295) and also the ionisation—that is, the number of partial molecules.

It also shows that the conductivity should increase with the concentration of the liquid, seeing that an increase in the number of decomposable molecules must be favourable to the movement of electricity. On the other hand, an increase in the number must give rise to an increased number of collisions; hence it is that, though for very dilute solutions the conductivity increases with the concentration, it does so more slowly than in direct ratio, and it is not difficult to understand that for some liquids there is a concentration which corresponds to a maximum conductivity, and this in a great many cases is below the point of saturation of the solution.

In dealing with molecular magnitudes, theoretical investigations make it probable that the electrolytic resistance, which the ions experience in being moved by the current, is of the same order of magnitude as the capillary resistance which results from their friction in the liquid (149). Nothing is opposed to the idea that electrolysis is a purely mechanical process. The substance becomes by solution in water (or other solvent) a conductor of electricity—that is, is ionised. The free ions carrying their charges of positive and negative electricity are moving about in all directions, but not more in one direction than in another; the difference of potential is the force in virtue of which they are urged in contrary directions. This motion constitutes the current; the resistance which the ions thereby experience is the electric resistance of the liquid. This, therefore, is the cause of the development of heat in the liquid.

938. **Transmissions effected by the current.**—The following experiments made by Davy illustrate the migration of the ions (943) in an electrolyte traversed by a current:—

i. He placed solution of sodium sulphate in two capsules connected by a thread of asbestos moistened with the same solution, and immersed the positive electrode in one of the capsules, and the negative electrode in the

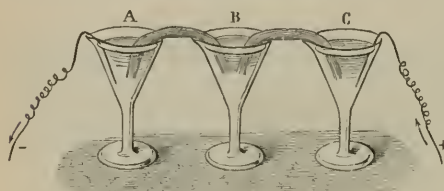

Fig. 949

other. The salt was decomposed, and at the expiration of some time all the sulphuric acid was found in the first capsule, and the soda in the second.

ii. Having taken three glasses, A, B, and C (fig. 949), he poured into the first solution of sodium sulphate, into the second dilute syrup of violets, and into the third pure water, and connected them by moistened threads of asbestos. The current was then passed in the direction from C to A. The sulphate in the vessel A was decomposed, and in the course of time there was nothing but sodium hydrate in this glass, which formed the negative end, while all the acid had been transported to the glass C, which was positive, B containing only coloured water. If, on the contrary, the current passed from A to C, the soda was found in C, while all the acid remained in A; but in both cases the remarkable phenomenon was seen that the syrup of violets in B became neither red nor green by the passage of the acid or base through its mass, a phenomenon which will be readily understood from what has preceded.

939. **Laws of electrolysis.**—The laws of electrolysis were discovered by Faraday; the most important of them are the following:—

1. *Electrolysis cannot take place unless the liquid is a conductor.* Ice is not decomposed by the battery. Other bodies, such as lead oxide, silver chloride, &c., are only electrolysed in a fused state—that is, when they can conduct the current. The converse of this is true; if a liquid transmits a current it must be an electrolyte. From the fact that he was able to obtain a current in liquids which deflected a galvanometer without producing any visible decomposition, Faraday inferred that liquids had a slight conductivity like that of metals independently of their electrolytic conductivity. Later

researches have shown that there is no current without decomposition. There may be a momentary movement of the needle of the galvanometer when the circuit is completed, but there is no permanent current.

II. *The energy of the electrolytic action of the current is the same in all its parts.*

For if a number of water voltameters, V , V' , V'' , are arranged in series so that they are all traversed by the same current (fig. 950), it is found that the weight of hydrogen in each of them in the same time is the same, whatever may be the size and distance apart of the electrodes, or the proportion and nature of the acid.

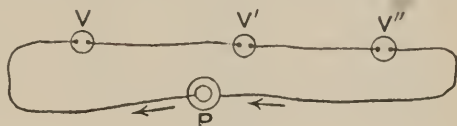

Fig. 950

If the current from the battery divides at A into two branches (fig. 951), in which are two equal voltameters V_1 and V_2 , then the quantities of gas liberated in V and V'' will still be equal to each other, and each equal to the sum of the quantities liberated in V_1 and V_2 , and the quantities in V_1 and V_2 will be inversely as the resistances of the two branches.

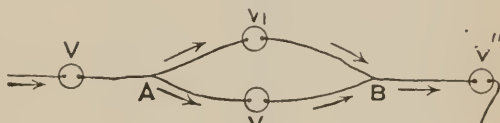

Fig. 951

III. *The same quantity of electricity—that is, the same electric current—decomposes chemically equivalent quantities of all the bodies which it traverses; from which it follows, that the weights of the ions separated in these electrolytes are to each other as their chemical equivalents.*

III. *The same quantity of electricity—that is, the same electric current—decomposes chemically equivalent quantities of all the bodies which it traverses; from which it follows, that the weights of the ions separated in these electrolytes are to each other as their chemical equivalents.*

In a circuit containing a water voltameter, V , Faraday introduced a tube, AB , containing tin chloride kept in a state of fusion by the heat of a spirit

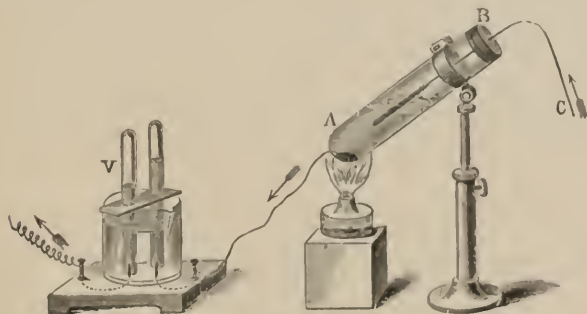

Fig. 952

lamp (fig. 952). In the bottom of the tube a platinum wire was fused which served as the cathode, while the anode consisted of a rod of graphite; when the current passed chlorine was liberated at the anode,

while tin collected at the kathode ; lead oxide contained in a similar tube was also electrolysed and yielded lead at the negative and oxygen at the positive electrode. Comparing the quantities of substances liberated, they are found to be in a certain definite relation. Thus for every 18 parts of water decomposed in the voltameter there will be liberated two parts of hydrogen, 207 parts of lead, and 117 of tin at the respective negative electrodes, and 16 parts of oxygen and 71 (or 2×35.5) parts of chlorine at the corresponding positive electrodes. Now these numbers are exactly as the chemical equivalents (not as the atomic weights) of the bodies.

It will further be found that in each of the cells of the battery 65 parts by weight of zinc have been dissolved for every two parts by weight of hydrogen liberated ; that is, that for every equivalent of a substance decomposed in the circuit one equivalent of zinc is dissolved. This is the case whatever be the number of cells. An increase in the number only has the effect of accelerating the decomposition. It does not increase the relative quantity of electrolyte decomposed. If in any of the cells more than 65 parts of zinc are dissolved for every two parts of hydrogen liberated, the excess arises from a disadvantageous local action (819) ; and the more perfect the battery, the more nearly is the ratio 65 : 2 satisfied.

Chemistry takes account of the *valency* of an element, and divides elements into *monads*, *dyads*, *triads*, and *tetrads*—a classification based on their equivalence to and their power of replacing other elements ; thus one atom of the monad hydrogen ($H = 1$), the basis of this classification, or one atom of monad silver ($Ag = 108$), would combine with one atom of chlorine ($Cl = 35.5$) or one atom of iodine ($I = 127$). One atom of oxygen ($O = 16$) unites with two atoms of hydrogen to form water, or with two atoms of silver to form silver oxide, Ag_2O ; one atom of the dyad zinc ($Zn = 65$) unites with one atom of the dyad oxygen to form ZnO , or with the dyad sulphur ($S = 32$) to form ZnS . Again, gold is a triad, and one atom ($Au = 196$) can combine with three atoms of chlorine to form $AuCl_3$, and, accordingly, one monad atom is equivalent to one-third of the atom of the triad. Now electrolysis proceeds according to the *equivalence* ; that is, the same quantity of electricity which liberates one atom of a monad liberates half an atom of a dyad, and a third of an atom of a triad. This remark applies also to the compound groups, such as NO_3 , which acts as a monad, and SO_4 , which acts as a dyad.

Thus if a current be passed through solutions of mercurous nitrate, $HgNO_3$, and mercuric cyanide, $Hg(CN)_2$, in series, while 200 grammes of mercury are separated in the former, 100 grammes will be separated in the latter.

IV. *The quantity of an electrolyte decomposed in a given time is proportional to the strength of the current.* This may be proved by inserting a water voltameter and a tangent galvanometer in a circuit with a variable number of Daniell cells, and comparing in each case the quantity of hydrogen evolved in a given time with the tangent of the angle of deflection of the galvanometer needle. The ratio will be found to be constant.

940. **Electrochemical equivalent.**—The electrochemical equivalent of an element is the weight in grammes of that element separated from a solution of its salt by the passage of the unit quantity of electricity, the unit

being either the absolute C.G.S. unit or one-tenth of this, the coulomb. The following table gives the atomic weight, valency, chemical equivalents, and electrochemical equivalents of various elements :—

Element	Atomic weight	Valency	Chemical Equivalent	Electrochemical Equivalents	
				Grs. per Coulomb	Coulombs per Gr.
Hydrogen	1	1	1	·00001038	96340
Oxygen	15·96	2	7·98	·00008283	12070
Chlorine	35·37	1	35·37	·0003671	2724
Sodium	23·00	1	23·00	·0002387	4189
Silver	107·7	1	107·7	·001118	894·5
Aluminium	27·4	3	9·01	·0000935	10700
Lead	206·4	2	103·2	·001071	933·7
Zinc	64·88	2	32·44	·0003367	2970
Copper (ic)	63·18	2	31·59	·0003279	3050
Copper (ous)	63·18	1	63·18	·0006558	1525
Iron (ic)	55·88	3	18·63	·0001934	5171
Iron (ous)	55·88	2	27·94	·0002900	3448
Mercury (ic)	199·80	2	99·90	·001037	964·3
Mercury (ous)	199·80	1	199·80	·002074	482·1

The chemical equivalent in the fourth column is obtained by dividing the atomic weight by the valency. Since by Faraday's law (839. iii.) chemically equivalent quantities of different elements are separated from their compounds by the same quantity of electricity, it follows that when the electrochemical equivalent of any element has been determined experimentally, that of any other may be calculated when the chemical equivalents of the two are known. For example, the electrochemical equivalent of zinc is derived from that of silver by multiplying $\cdot001118$ by $\frac{32\cdot44}{107\cdot7}$, the ratio of the chemical equivalents of zinc and silver.

From the above table we see that 96,340 coulombs are required to separate 1 gramme of hydrogen from 8 grammes of oxygen, that is, to decompose 9 grammes of water; or, otherwise, we may say that a coulomb of electricity in traversing an electrolyte carries with it a weight of a metal which is represented by its electrochemical equivalent. The quantity of electricity which is thus associated with an atom of hydrogen or other monovalent element represents a minimum quantity of electricity—the electric atom or *electron* (982) as it has been called by Johnstone Stoney. By various theoretical considerations it has been attempted to estimate its amount; Richarz obtained the number $1\cdot29 \times 10^{-10}$, Ebert $1\cdot4 \times 10^{-10}$, and Stoney 3×10^{-10} electrostatic units; numbers which, arrived at independently, agree very well as to the order of their magnitude. The most recent value obtained by Professor J. J. Thomson is $1\cdot34 \times 10^{-10}$. It was calculated by Weber that if the quantity of positive electricity required to decompose a grain of water were accumulated on a cloud at a distance of 3000 feet from the earth's surface, it would exert an attractive force upon the earth of upwards of 1500 tons. Helmholtz estimated that if the +E attached to the atoms of 1 milligramme of water could be transferred without loss to a sphere,

and the $-E$ similarly to another sphere at a distance of a kilometre, the two spheres would attract each other with a force equal to the weight of 26,800 kilogrammes.

If w represents the weight of an element separated from one of its compounds by the passage of a quantity Q coulombs of electricity, or by a current of C amperes for t seconds, and if z is the electrochemical equivalent of the element,

$$W = zQ = zCt.$$

941. Voltmeters.—A voltmeter is an apparatus for decomposing an electrolyte in which the relation between z and Q can be determined. It may be used for measuring the strength of current when uniform, if the electrochemical equivalent of one of the constituents of the electrolyte is known, for w and t can be observed and measured; or, conversely, by passing a known constant current for a definite time through a voltmeter the electrochemical equivalent of the electrolyte and of its constituents may be determined.

A voltmeter must be distinguished from a voltmeter which measures difference of potential. A voltmeter is generally used as a measurer of electric quantity.

Water voltmeter.—A convenient form of apparatus for determining the electrochemical equivalent of hydrogen is shown in fig. 953. It is a vessel containing pure dilute sulphuric acid, through the base of which pass two platinum wires, terminating in platinum plates e, f . P is a glass bulb connected by a fine tube to a wider tube enveloping the plate f . Its volume from the stopcock at the top to a mark on the fine tube near the dotted line is carefully determined beforehand, as is also the volume of the fine tube per centimetre of length. When an experiment is to be made, the dilute acid is drawn up to the top of the bulb by aspiration, and e and f are connected in circuit with a tangent galvanometer or ammeter, and a battery of 3 or 4 storage cells (947), care being taken that the positive pole is connected to e . The oxygen evolved escapes into the air, the hydrogen displaces the liquid in the bulb P , and the circuit is broken when the level of the liquid reaches the neighbourhood of the mark in the fine tube, the interval during which the current has been flowing being noted. The weight of hydrogen is determined

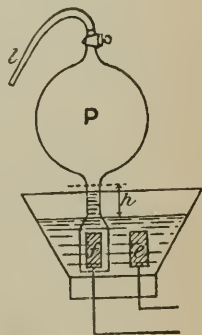

Fig. 953

from the observed volume v by the formula $w = \frac{v \times d}{1 + at} \cdot \frac{\phi}{76}$ (333); in which d

is the density of hydrogen at 0° and 76 cm. = $\cdot 00009$, $a = \frac{1}{273}$, ϕ is the pressure of dry hydrogen in the bulb, and t is the temperature. The bulb contains a mixture of dry hydrogen and aqueous vapour. The pressure of the latter ϕ_1 may be obtained from a table (361). If B = the reduced height of the barometer in cm., ϕ_2 the pressure in cm. of mercury due to the height h of liquid in the tube, the pressure of the mixed gases is $B - \phi_2$;

hence $p = B - p_2 - p_1$. When the value of w has been calculated, z , the electrochemical equivalent of hydrogen, is given by the formula

$$z = \frac{w}{Ct}$$

It is usual to measure the volume of the hydrogen rather than that of the oxygen, in consequence of uncertainty as to the amount of the latter converted into ozone and peroxide of hydrogen, but sometimes the volume of the mixed gases is measured. A convenient apparatus for this purpose is represented in fig. 954. The vessel a is that in which the water is decomposed; it contains two platinum plates, and is in connection with the flask b , which contains water. In this is a lateral delivery tube, c , which is inclined until the level of the liquid in it is the same as in the funnel tube n . The air is then under the same pressure as the atmosphere. When the battery is connected with the decomposing cell a , the gases disengaged expel a corresponding volume of water through the delivery tube c ; at the conclusion of

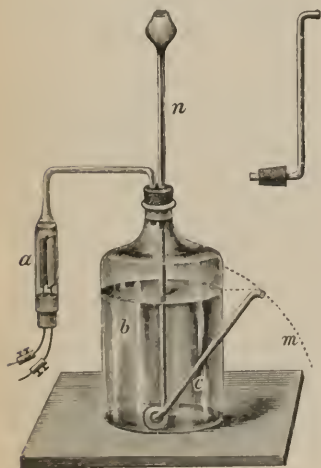

Fig. 954

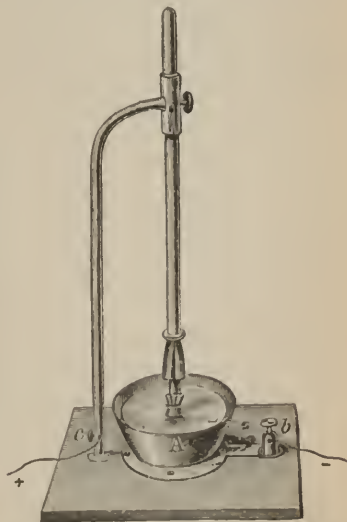

Fig. 955

the experiment, this tube is inclined until the liquid is at the same level as in the tube n and in the flask. The weight of the liquid expelled is then a direct measure of the volume of the disengaged gases.

Silver voltameter.—One form of *silver voltameter* is shown in fig. 955. A solution of silver nitrate is placed in a platinum dish A , of known weight, resting on a brass plate that can be connected with the negative pole of the battery by means of the binding screw b . In this solution dips the positive electrode, which consists of a rod of silver wrapped round with muslin, and suspended to an adjustable support.

When the current passes, silver is deposited on the inside of the platinum dish, and after a certain time the current is stopped and the dish washed,

dried, and weighed ; the increase of weight is a very accurate measure of the quantity of electricity which has passed. Or, if a tangent (or other measuring) galvanometer is included in the circuit and the current maintained constant by means of a rheostat, the electrochemical equivalent of silver may be determined, since $w = zCt$, where w is the increase of weight of the platinum dish in grammes due to the deposited silver, C the current in amperes, and t the time in seconds. Any silver particles which may become detached from the silver anode are retained in the muslin.

Edison has used a *zinc voltameter* for measuring quantities of electricity employed for technical purposes.

Lord Kelvin uses a *copper voltameter*, consisting of two copper plates, immersed in a slightly acid and nearly saturated solution of copper sulphate, for standardising the various ampere-meters he has devised. Care must be taken that the *density of the current*—that is, the actual current divided by the area (in sq. cm.) of the cathode plate exposed—does not exceed a certain value, which is generally about $1/70$; in other words there should be 1 ampere for every 70 square centimetres of plate exposed.

942. **Resistance of a liquid.**—Liquids only conduct by being electrolysed (939) ; such liquids as pure ether, turpentine, benzole, and even water, do not conduct. Solutions of acids of a certain strength are the best conducting liquids known.

The most important of recent researches on the conductivity of liquids are those of Kohlrausch. Owing to the effects of polarisation of the electrodes, which give rise to unknown electromotive forces, it is difficult to get very accurate results with the ordinary methods, and Kohlrausch introduced the use of alternating currents, employing for this purpose those of a small induction coil. His apparatus consisted essentially of a Wheatstone's bridge arrangement, in one arm of which was introduced the liquid resistance to be determined. For the rarer liquids he used such vessels as are represented in fig. 956, which consists of two small glass vessels joined by a glass tube 3 to 9 mm. in the clear. In these are placed cup-shaped electrodes of platinised platinum, in the centre of which are small apertures to allow gas to escape. In place of the galvanometer an electro-dynamometer was used, and more recently the telephone was found of great service (971). The resistances were varied in the other branches until the sound heard in the telephone was reduced to a minimum.

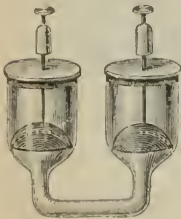

Fig. 956

In another method the tube containing the liquid and a box of resistance coils are included in a simple circuit with battery and key. The difference of potential between two points in the tube is measured by a quadrant electrometer and compared with the difference of potential at the terminals of the box of coils in which a known resistance is unplugged. If L and R are the resistances of liquid and coils respectively, and e_1, e_2 the corresponding D.P.s, since the same current flows through both, $\frac{e_1}{L} = \frac{e_2}{R}$, $\therefore L = R \frac{e_1}{e_2}$. From this the specific resistance of the liquid is obtained if the tube is uniform and of known length and section.

943. **Migration of the ions.**—From what has been said, it would seem that when a solution of copper sulphate is electrolysed between copper electrodes, for any weight of copper deposited at the kathode an equal weight should enter into the solution at the anode, and, the transfer taking place as described, the concentration of the solution should remain unchanged. This, however, is not the case; when the operation takes place without any agitation of the solution, the liquid about the kathode becomes lighter in colour, indicating that the solution there is weaker.

This phenomenon, which was investigated by Hittorf, is ascribed by him to the fact that in electrolysis both electricities associated with their *ions* or products of electrolytic decomposition, travel in the liquid towards their respective electrodes, but with unequal velocities, and this transference is called the *migration of the ions*. Each ion has a special velocity in the liquid independently of the compound of which it forms part; thus in CuSO_4 solution SO_4 travels twice as fast as Cu .

The number which expresses this relative rate of travel is called n , and has this meaning: let us conceive a vertical layer in the liquid the concentration of which remains unchanged by what takes place on each side; then, if after electrolysis we determine the quantity of the constituents on each side, there is an increase of the positive on one side and of the negative on the other. These increases correspond to the quantities of the two constituents which have been driven through.

The number n expresses the ratio of the number of molecules of the anion which passes through the imaginary layer in a given time to the sum of the molecules of anion and kation.

If k is the velocity of the kation, and a that of the anion, then

$$n = \frac{a}{k+a}; \quad 1-n = \frac{k}{k+a}; \quad \frac{1-n}{n} = \frac{k}{a}.$$

Hittorf has shown that n is a constant independent of the strength of the current, but varying with the concentration of the liquid.

944. **Polarisation.**—When the platinum electrodes, which have been used in decomposing water, are disconnected from the battery, and connected with a galvanometer, the existence of a current is indicated which has the opposite direction through the electrolyte to that which had previously passed. This phenomenon is explained by the fact that oxygen has been condensed on the surface of the positive plate, and hydrogen on the surface of the negative plate, analogous to what has been already seen in the case of the non-constant batteries (820). The effect of these is to set up an electromotive force e opposed to that of the battery and called *the electromotive force of polarisation*. The polarisation is not instantaneous, but may increase continuously from zero to a certain maximum limit which may be considerable; the E.M.F. of polarisation increases with the strength of the current, attaining a value of about 1.5 volt with platinum plates in dilute sulphuric acid. It constitutes a negative electromotive force, and must be allowed for in Ohm's formula (845), which then becomes, when applied to a circuit containing a battery whose E.M.F. is E , and an electrolyte in which the E.M.F. of polarisation is e , $C = \frac{E - e}{R}$, R being the total resistance of the circuit.

The quantity of electricity required to produce a given state of polarisation depends on the condition and dimensions of the plate, and is often called the *capacity of polarisation* relative to the given system. When the electrodes consist of plates of the same metal as that of the salt decomposed, there is practically no polarisation. Thus the polarisation is negligible when a copper salt is electrolysed between copper electrodes or a silver salt between silver electrodes.

If a test tube containing mercury is placed in a vessel of mercury, and the electrodes of a voltaic battery are connected with the two masses of mercury separated by the glass, no current passes at the ordinary temperature. But, if the arrangement is gradually heated, a current is set up which increases with the temperature, while the physical condition of the glass appears quite unchanged. If the battery is removed and the electrodes connected with a galvanometer, a current in the opposite direction to the primary one is observed. The surfaces of the mercury in contact with the glass are thus polarised, and the electricity must have been transmitted by the hot glass, which must therefore have undergone a certain amount of decomposition.

945. **Secondary batteries. Grove's gas battery.**—On the property, which platinum has, of condensing gases on its surface, Sir W. Grove constructed his *gas battery* (fig. 957). A single cell consists of two glass

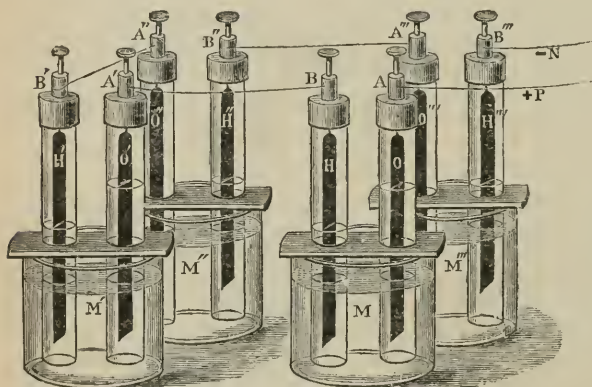

Fig. 957

tubes, B and A, in each of which is fused a platinum electrode, provided on the outside with binding screws. These electrodes are made more efficient by being covered with finely divided platinum. The tubes being filled with the dilute acid, a current from an independent battery

is allowed to pass through the liquid from A to B until B is nearly full of hydrogen, when A will be about half full of oxygen. The vessel M with its tubes, when detached from the battery, has now the properties of a voltaic cell. If A and B are joined to a galvanometer, the deflection of the needle shows that A is the positive and B the negative pole. The E.M.F. is about 1.5 volt. The action of the cell when discharging is to decompose the liquid in the cell, hydrogen being produced at A which combines with the oxygen to re-form water. Similarly in the B tube oxygen is evolved, which combines with the hydrogen; so that the liquid rises in both tubes, but twice as fast in B as in A. The action ceases when the gases have disap-

peared from both tubes, and the cell must be recharged from an independent source.

These cells can be formed into a battery (fig. 957) by joining the dissimilar plates with one another just as they are joined in an ordinary battery. One cell of such a battery is sufficient to decompose potassium iodide, and four will decompose water.

946. **Planté battery.**—Ritter was, however, the first to show that on this principle batteries might be constructed of pieces of metal of the same kind—for instance, platinum—which otherwise give no current. A piece of moistened cloth is interposed between a pair of metal plates, and the ends of this system are connected with the poles of a battery. After some time the apparatus has received a charge, and if separated from the battery can itself produce all the effects of a voltaic battery. Such batteries are called *secondary* batteries. Their action depends on an alteration of the surface of the metal produced by the electric current, the constituents of the liquid with which the cloth is moistened having become accumulated on the opposite plates of the secondary cell.

Planté first showed the practical importance of these batteries. His cell (fig. 958) is constructed as follows: A broad strip of sheet lead with a tongue is laid upon a second

similar sheet, contact being prevented by narrow strips of felt; and two similar strips having been laid on the upper piece, the sheets are rolled together so as to form a compact cylinder. This is placed in a vessel containing dilute sulphuric acid, and, being connected

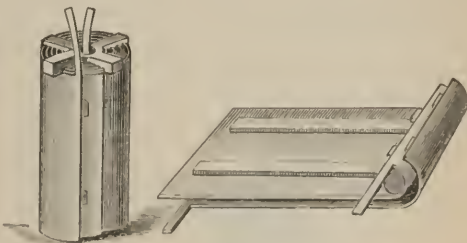

Fig. 958

with a battery of 4 or 5 volts, a current (the primary current) is passed through it. The effect of this is that water is decomposed, oxygen being liberated at the anode plate, and hydrogen at the cathode. The oxygen unites with the lead, forming peroxide of lead. If now the plates are detached from the charging battery and are connected with each other, a powerful current is produced in the opposite direction to the primary; the oxygen of the peroxide at the anode, produced by the decomposition of the dilute acid, combines with the hydrogen, while the lead plate is oxidised. When these operations are repeated several times, the charging current after each discharge being reversed in direction, the activity of the cell increases, owing to the metallic lead which is reduced from the oxide being in a more voluminous and less compact condition, and presenting a much larger surface than the original lead. It is known as *spongy lead*.

947. **Storage batteries. Accumulators.**—Faure made a great improvement in the preparation of the plates. It consists in coating the lead plates with a thick paste of red lead, Pb_3O_4 , so as to have about one gramme to the square centimetre. This is kept in its place by a sheet of parchment paper and slips of felt, and is then coiled up as in Planté's (fig. 959).

When the current is passed, the ultimate effect is that the red lead at the one electrode is oxidised to PbO_2 , while the other is reduced to granular porous grey metallic lead, both which coatings present a large surface. Such coatings, however, are liable to become detached, and a considerable advance was made in the introduction of *grids*, or gratings of lead in which square or round holes are filled with compressed lead oxide; the object being to store firmly as much of the porous material as possible, consistently with strength, lightness, and compactness.

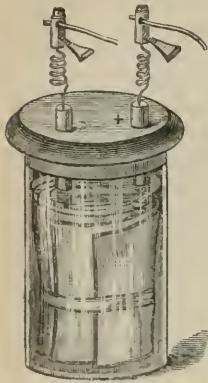

Fig. 959

There are many plans by which this may be effected. Fig. 960 represents one of the cells of the Electric Power Storage Company; it will be seen that the whole of one set of six plates, forming the negative electrode, are fixed together, and a corresponding set of five plates, also joined together, can be placed between the other set, being kept from touching each other by staples or studs of some

insulating material. Each set of plates forms in effect a single large plate, which is thus placed with its coated face opposite the coated faces of the other plate. The object of bringing the plates near each other is to diminish the internal resistance.

The electromotive force of such a cell while it is being charged rises to about $2\frac{1}{2}$ volts, so that a larger E.M.F. than this is required to charge it.

In charging, a considerable number of these cells are often arranged in parallel. By means of a specially contrived commutator a given number of such cells may be combined so as to produce at will the effects either of high potential or of quantity.

The fact that these cells after having been once charged retain the charge for a considerable time has led to their use in what is called 'storing electricity' produced by mechanical power through the agency of powerful dynamo machines. What they do is to store the products of chemical decomposition in a form in which they are immediately available for electric effects.

They are usually charged by shunt wound dynamos (991), whereby about 75 per cent. of the energy is available. An accumulator of a given size can only

consume in each interval of time a definite quantity of gas for its formation by oxidation and reduction. If more gas is developed it escapes uselessly. The charging current must be neither too strong nor too weak. For each

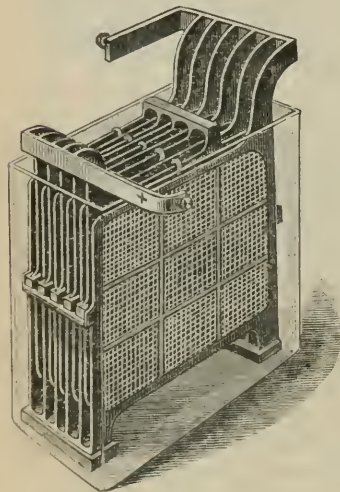

Fig. 960

accumulator there is a special rate of charge and of discharge, which is most advantageous.

Fig. 961 represents the course of charging an accumulator in an actual experiment in which the charging was continued for 22 hours. In the first hour or so the E.M.F. rose rapidly until it was about 2.08 volts, when it was almost stationary for about 10 hours when 220 ampere-hours had been put in,

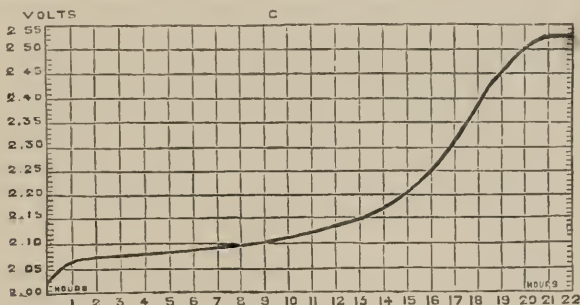

Fig. 961

and the E.M.F. was 2.13 volts; from this point the E.M.F. rose more rapidly, until it reached 2.53 volts at the end of 21 hours. The maximum usually obtained is 2.5 volts, at which the liquid becomes milky owing to a disengagement of gas in the body of the liquid itself, which indicates that the charge is complete.

A charged accumulator gradually loses its charge by leakage, and the efficiency of an accumulator depends on the power of retaining its charge. In this respect great improvement has been made by attention to a number of minute points; the durability now extends to years, whereas it was formerly measured by months or weeks.

The *capacity* of an accumulator, which must not be confounded with electrostatic capacity (760), is measured in terms of *ampere-hours*. A cell whose capacity is 100 ampere-hours would furnish a current of 1 ampere for 100 hours, 2 amperes for 50 hours, and so on. The capacity depends, of course, on the number and size of the plates—that is, on the weight of lead used.

Of perhaps greater importance in judging of an accumulator is the *efficiency*, by which is meant the ratio of the energy it gives out during discharge to that which it absorbs during charge. The energy stored up in an accumulator is measured by the potential at the terminals during the charging, multiplied by the strength of the current and by the time. The product gives the energy in volt-ampere-seconds or joules (860). In like manner the energy given out in the discharge is the potential into the current strength into the time of discharge. The whole charge which can be imparted to an accumulator cannot be advantageously utilised, for the accumulator is injured if this is done, and in practice the charge is only allowed to run down until the potential is 10 per cent. less than at starting.

Thus a given accumulator was charged for 10.16 hours with a current of 5 amperes, the average potential being 2.15 volts; hence the energy stored

is $10 \cdot 16 \times 2 \cdot 15 \times 5 = 109$ watt-hours. In the discharge, which lasted 7.35 hours, the average potential was 1.88, and the currents 6.5 amperes, representing therefore 90 watt-hours; the ratio of the two is 0.826—that is, the efficiency of the accumulator is 82.6 per cent.; a number which is now required for a good accumulator.

It cannot be said that the reactions which take place during the charge and discharge of an accumulator are thoroughly understood; they are undoubtedly more complicated than has been represented above, in which no account has been taken of the sulphuric acid. During the charge the strength of the dilute sulphuric acid, and therewith its conductivity, gradually diminish, while during the discharge both increase. Hence a determination of the specific gravity of the solution at any time is a convenient practical method of measuring the state of the charge. This is effected by flat densimeters (129) which float between the plates. The density may vary between 1.12 and 1.22, representing respectively about 16 and 30 per cent. of sulphuric acid, SH_2O_4 .

As an example, one cell of the Electric Power Storage Company had an internal resistance of 0.0012 ohm at the beginning, and 0.0028 at the end, and weighed 50 kilos. In such a cell 880 watt-hours could be accumulated, and 680 watt-hours, or about 79 per cent., obtained in the discharge. Thus each kilo. represents 13.6 watt-hours of available energy, or $\frac{1}{54}$ of a horse-power; that is, it could yield $\frac{1}{54}$ H.P. for an hour, or 1 H.P. for 1.1 minute.

In accumulators which are to be used to work motors, as in trams, electric boats, &c., the *capacity* is of first importance, while with stationary accumulators, as in electric lighting, the efficiency is the chief point.

Many instructive comparisons may be made between a secondary battery and a charged Leyden jar. Thus, for instance, when the poles of a secondary battery have been connected until no current passes, and are then disconnected for a while, a current in the same direction as the first is obtained on again connecting them; this is the *residual discharge*. The capacity of a secondary battery depends on the area of the electrodes, on their nature, and on that of the interposed liquid, but not on the distance between them. The energy of the Leyden jar is stored in that state of mechanical strain which is called polarisation of the dielectric; in the secondary battery the energy consists in the products which are stored up on the surface of the electrodes in a state ranging from chemical combination to mechanical adherence or simple juxtaposition.

A dry battery (829) which has become inactive may be used as a secondary battery. When a current is passed through it, in a direction contrary to that which the active battery would itself yield, it regains its activity to a certain extent.

948. **Nobili's rings.**—When a drop of copper acetate is placed on a silver plate, and the silver is touched in the middle of the drop with a piece of zinc, there are formed around the point of contact a series of copper rings alternately dark and light. These are *Nobili's coloured rings*. They may be obtained in beautiful iridescent colours by the following process: A solution of lead oxide in potash is obtained by boiling finely powdered litharge

in a solution of potash. In this solution is immersed a polished plate of silver or of german silver, which is connected with the positive electrode of a battery of 10 volts. With the negative pole is connected a fine platinum wire fused in glass, so that only its point projects; and this is placed in the liquid at a small distance from the plate. Around this point lead peroxide is separated on the plate in very thin concentric layers, the thickness of which decreases from the middle. They show the same series of colours as Newton's coloured rings in transmitted light (664). The lead peroxide owes its origin to a secondary decomposition; by the passage of the current some lead oxide is decomposed into metallic lead, which is deposited at the negative pole, and oxygen which is liberated at the positive; and this oxygen combines with some lead oxide to form peroxide, which is deposited on the positive pole as the decomposition proceeds. This process is used for the metallic coloration of objects of domestic use and ornamentation.

The effects are also well seen if a solution of copper sulphate is placed on a silver plate, which is touched with a zinc rod, the point of which is in the solution; for then a current is formed by these metals and the liquid.

949. *Arbor Saturni*, or lead tree. *Arbor Dianæ*.—When in a solution of a salt is immersed a metal which is more oxidisable than the metal of the salt, the latter is precipitated by the former, while the immersed metal is substituted, equivalent for equivalent, for the metal of the salt. This precipitation of one metal by another is attributable partly to the difference in their affinities, and partly to the action of a current which is set up as soon as a portion of the less oxidisable metal has been deposited. The action is promoted by the presence of a slight excess of acid in the solution.

A remarkable instance of the precipitation of one metal by another is the *Arbor Saturni*. This name is given to a series of brilliant ramified crystallisations obtained by zinc in solutions of lead acetate. A glass flask is filled with a clear solution of this salt, and the vessel closed with a cork, to which is fixed a piece of zinc in contact with some copper wire. The flask, being closed, is left to itself. The copper wire at once begins to be covered with a moss-like growth of metallic lead out of which brilliant crystallised laminae of the same metal continue to form; the whole phenomenon has great resemblance to the growth of vegetation, from which indeed the old alchemical name is derived. For the same reason the name *Arbor Dianæ* has been given to the metallic deposit produced in a similar manner by mercury in a solution of silver nitrate.

If a rod of zinc is dipped in an acid solution of stannous chloride, crystallised tin is formed upon it; the experiment is rendered more beautiful by dipping the platinum electrodes of a battery in the solution; if the poles are reversed, the crystallised laminae disappear at one pole to reappear at the other.

950. *Electrocapillary phenomena*.—If a drop of mercury is placed in dilute sulphuric acid containing a trace of chromic acid, and the end of a light iron wire be so fixed that it dips in the acid and just touches the edge of the mercury, the latter begins a series of regular vibrations which may last for hours. The explanation of this phenomenon, which was first

observed by Kühne, is as follows :—When the iron first touches the mercury, an iron-mercury couple is formed, in consequence of which the surface of the mercury is polarised by the deposition of an invisible layer of hydrogen; this polarisation (820) increases the surface-tension of the mercury (137), it becomes rounder, and contact with the iron is broken; the chromic acid present depolarises the mercury, its original shape is restored, the couple is again formed, and the process repeats itself continuously.

Lippmann was led by the observation of this phenomenon to a series of interesting experimental results, which have demonstrated a relation between capillary and electric phenomena. Of these results the most important is the construction of a *capillary electrometer*.

A glass tube, A (fig. 962), is drawn out to a fine point, and is filled with mercury: its lower end dips in a glass vessel, B, containing mercury at the bottom and dilute sulphuric acid at the top. Platinum wires are fused in the tubes A and B, and terminate in the binding screws *a* and *b* respectively.

At the beginning of the experiment, the position of the mercury in the drawn-out tube is such that the pressure due to the surface-tension at

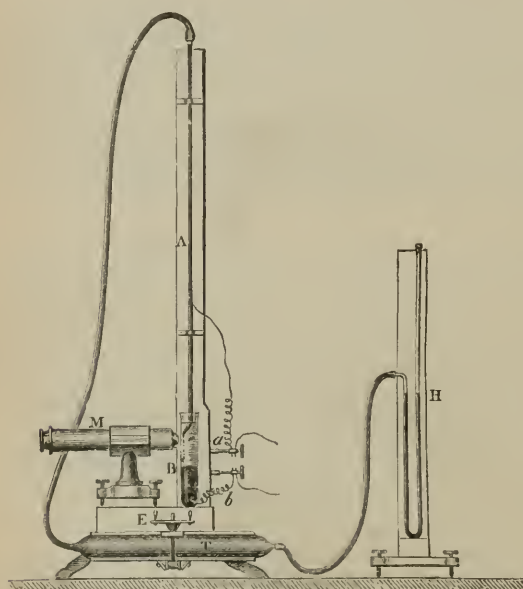

Fig. 962

the surface of separation of the mercury in the tube and the liquid is sufficient to counterbalance the pressure of the column of mercury, A. This position is observed by means of a microscope, the focus of which is at the fiducial mark on the glass at which the mercury stops. If now a difference of potential is established between *a* and *b*, *b* being at the higher potential, the surface-tension of the mercury in the capillary tube is increased, the mercury ascends, and in order that the meniscus may be brought to its former position the pressure on A must be increased. This increase is most simply effected by means of a thick india-rubber tube or bag, T, connected with the top of A, and with a manometer, H, and capable of more or less compression by means of a screw, E. The difference in level of the two legs of the manometer is thus a measure of the increase of the surface-tension, and therewith of the difference of potential. Lippmann

found that, b being at the higher potential, the capillary surface continues to rise until the D.P. is about $\cdot 9$ volt, beyond which it descends, indicating a diminution in the apparent surface-tension. Up to $\cdot 6$ volt the curve giving the relation between the D.P. and the pressure which must be applied to bring back the mercury to the fiducial mark is a straight line, showing that D.P. is proportional to pressure. If a is at a higher potential than b , the mercury surface moves downwards, whatever the D.P. This apparatus is much used in physiological work; the electromotive force applied to it should not exceed $0\cdot 6$ volt, but it can estimate the one-thousandth part of this quantity, and, as its electric capacity is very small, it shows rapid changes of potential, which ordinary electrometers cannot do. For very small electromotive forces, the pressure is kept constant, and the displacement of the meniscus is measured by the microscope. In practical use as an electrometer b is always at a higher potential than a .

Dewar suggested a modified form of the capillary electrometer in which a fine horizontal tube of about 1 mm. diameter contained mercury with a drop of acid at the centre. The ends of the tube are fitted into lateral tubulures in glass bottles containing mercury. A difference of potential of $\cdot 003$ volt causes the drop of acid to move in the direction of the current along the tube.

951. **Electric endosmose.**—By electric endosmose is meant the passage of matter with the current through a porous diaphragm. The phenomenon is observed in the following experiment, due to Porret:—Having divided a glass vessel into two compartments by a porous diaphragm, he poured water into the two compartments to the same height, and immersed two platinum electrodes in connection with a battery of 80 cells. As the water became decomposed, part of the liquid was carried in the direction of the current through the diaphragm, from the positive to the negative compartment, where the level rose above that in the other compartment. A solution of copper sulphate is best for these experiments, because then the disturbing influence of the disengagement of gas at the negative electrode is avoided.

A porous vessel is necessary, for otherwise the transport by the liquid would be at once hydrostatically equalised.

The converse of these phenomena, that is, the production of electric currents, when a liquid is forced through a diaphragm by mechanical means, has also been observed. Such currents, which were discovered by Quincke, are called *diaphragm currents*. A porous diaphragm, p , is fixed in a glass tube (fig. 963), in which are also fused two platinum wires terminating in platinum electrodes, a and b ; on forcing a liquid through the diaphragm the existence of a current is evidenced by a galvanometer with which the wires are connected, the direction of the current being that of the flow of the liquid. The difference of potential due to this flow is proportional to the pressure.

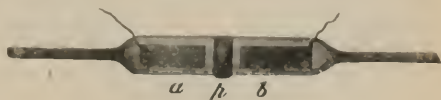

Fig. 963

According to Zöllner, all circulatory motions in liquids, especially when they take place in partial contact with solids, are accompanied by electric currents, which have generally the same direction as that in which the

liquid flows. And he regards earth currents as analogous to diaphragm currents; there are currents in the liquid mass in the interior of the earth, and these currents coming in contact with the solidified masses produce electric currents.

Wertheim found that the elasticity of metal wires is diminished by the current, and not by the heat alone, but by the electricity; he has also found that the cohesion is diminished by the passage of a current.

952. **Calculation of E.M.F. of polarisation.**—Supposing the electric current to flow through dilute sulphuric acid between platinum electrodes without any polarisation, the electric energy absorbed in the liquid and converted into heat would be C^2Rt , C being the current and R the resistance between the electrodes. But in the actual case, some of the energy of the current is employed in decomposing the water and separating hydrogen from oxygen, giving rise to the back E.M.F., e . The energy so spent during the passage of a quantity Q of electricity is eQ ergs, if e and Q are measured in absolute units, or $eQ \times 10^7$ ergs, if e is measured in volts and Q in coulombs, since 1 volt = 10^8 C.G.S. units of E.M.F., and one coulomb = 10^{-1} C.G.S. units of current. Now we know that when 1 gramme of hydrogen is burnt in oxygen to form 9 grammes of water, 34,000 calories of heat are produced, and since 1 calorie is equivalent to 4.2×10^7 ergs (860), it follows that the combustion of 1 gramme of hydrogen yields $34,000 \times 4.2 \times 10^7$ ergs. If we assume that to separate 1 gramme of hydrogen from water the same quantity of energy is required as is afforded by the union of 1 gramme with oxygen to form the water, then, since the electrolysis of 9 grammes of water (yielding 1 gramme of hydrogen) requires 96,340 coulombs (940), it follows that $e \times 10^8 \times Q = e \times 10^8 \times 96,340 = 34,000 \times 4.2 \times 10^7$,

$$\begin{aligned} \text{therefore } e &= \frac{34 \times 4.2}{963.4} \\ &= 1.482 \text{ volt.} \end{aligned}$$

This agrees with the E.M.F. of polarisation as measured directly. If lead electrodes are used the chemical changes are not so simple, and, as we have seen, the back E.M.F. may rise to $2\frac{1}{2}$ volts.

In the case of cells whose E.M.F. is independent of changes of temperature (858), the E.M.F. may be calculated from the heat equivalents of the chemical changes taking place in the cell, in the manner illustrated above in the electrolysis of acidulated water. But with cells whose E.M.F. changes with change of temperature this is not the case. The reason is that with such cells the electric and chemical energies are not equal to each other.

953. **Electrometallurgy.**—The decomposition of salts by the battery has received a most important application in *electrometallurgy*, or *galvanoplastics*, or the art of precipitating certain metals from their solutions by the action of an electric current. The processes are twofold; in the one, *electrotyping* or *galvanoplastics* proper, a mould is used, on which a metal, usually copper, is more or less thickly deposited; the deposit can afterwards be detached, and gives a copy of the original object; in the other, which is known as *electroplating*, a thin coherent coating of metal—gold or silver, for instance—is deposited on objects and remains adherent to them. The art

was discovered independently by Spencer in England and by Jacobi in St. Petersburg.

In order to obtain a galvanoplastic reproduction of a medal or any other object, a mould must first be made, on which a layer of metal is deposited by the electric current.

For this purpose several substances are in use, and one or another is preferred according to circumstances. For medals and similar objects which can be submitted to pressure, gutta-percha may be used with advantage. The gutta-percha is softened in hot water, pressed against the object to be copied and allowed to cool, when it can be detached without difficulty. For the reproduction of engraved wood blocks or type, wax moulds are now commonly used. They are prepared by pouring into a narrow flat pan a suitable mixture of wax, tallow, and Venice turpentine, which is allowed to set, and is then carefully brushed over with very finely powdered graphite. While this composition is still somewhat soft, the wood block or type is pressed upon it either by a screw press or, still better, by hydraulic pressure. If plaster-of-Paris moulds are to be made use of, it is essential that they be first thoroughly saturated with wax or tallow, so as to become impervious to water.

In all cases, whether the moulds are of gutta-percha or wax, or any other non-conducting substance, it is of the highest importance that the surface be brushed over very carefully with graphite, and so made a good conductor while not sensibly altered in sharpness. The conducting surface thus prepared must also be in metallic contact with a wire or a strip of copper by which it is connected with the negative pole of the battery. Sometimes the moulds are made of a fusible alloy (343), which may consist of 5 parts of lead, 8 of bismuth, and 3 of tin. Some of the melted alloy is poured into a shallow box, and just as it begins to solidify, the medal is placed horizontally on it in a fixed position. When the alloy has become cool, a slight shock is sufficient to detach the medal. A copper wire is then bound round the edge of the mould, by which it can be connected with the negative pole of the battery, and then the edge and the back are covered with a thin non-conducting layer of wax or shellac, so that the deposit is formed only on the mould itself.

The most suitable arrangement for producing an electro-deposit of copper consists of a trough of glass, slate, or wood, lined with india rubber or

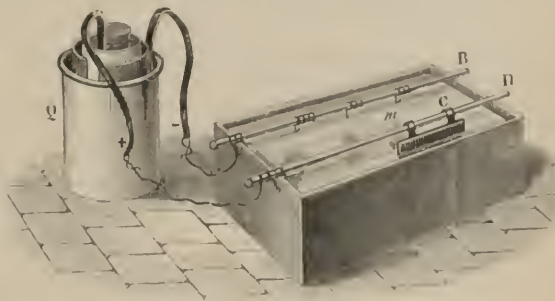

Fig. 964

coated with marine glue (fig. 964). This contains an acid solution of copper sulphate, and across it are stretched copper rods, B and D, connected

respectively with the negative and positive poles of a battery. By their copper conductors the moulds, *m*, are suspended in the liquid from the negative rod B, whilst a sheet of copper, C, presenting a surface about equal to that of the moulds to be covered, is suspended from the positive rod D, at the distance of about two inches, directly opposite to them.

The copper plate suspended from the positive pole not only acts as an electrode, but keeps the solution in a state of concentration, for the acid liberated at the anode dissolves the copper, and reproduces a quantity of copper sulphate equal to that decomposed by the current.

The battery employed for the electric deposition of metals ought to be one of great constancy. Batteries such as Daniell's and Smee's formerly used, have in large establishments been supplanted by accumulators, or by dynamo machines (988), which furnish the electricity at one quarter the expense, and which are especially constructed to furnish currents of small E.M.F.

The *density* of a current (941) is its strength divided by the surface of the electrodes, or the number of amperes per square centimetre, and a statement of this density in conjunction with a knowledge of the composition and strength of the bath is a succinct way of defining the conditions of electric deposition. The density at the electrodes has a great influence on the form in which the ions are separated out; thus with a moderate density silver separates in a crystallised form, and at a greater one in the form of a black powder.

An important industrial application is made of electrolysis in the *refining of copper*. The metal is extracted by the ordinary metallurgical processes so as to yield plates containing 95 per cent. of pure copper. These plates are then used as positive electrodes in a bath of copper sulphate, and the metal is deposited in a state of perfect purity on thin sheets of pure copper, which form the negative electrode, while the impurities fall to the bottom. As the electrodes are practically identical, there is no polarisation (820), and the work of the current is solely employed in overcoming the resistance of the baths. The application of electrolysis to the extraction of metals was of limited use until the powerful currents of dynamos became available. In mountainous countries, where water-power can be had, it may in many cases be practicable to deal *in situ* with the extraction of metals from their ores.

954. **Electroplating.**—The old method of gilding was by means of mercury. It was effected by an amalgam of gold and mercury, which was applied on the metal to be gilded. The objects thus covered were heated in a furnace, the mercury volatilised, and the gold remained in a very thin layer on the objects. The same process was used for silvering; but they were expensive and unhealthy methods, and have now been entirely replaced by electroplating and electrosilvering. Electroplating only differs from the process described in the previous paragraph in that the layer is thinner and adheres more firmly. Brugnatelli, a pupil of Volta, appears to have been the first, in 1803, to observe that a body could be gilded by means of the battery and an alkaline solution of gold; but De la Rive was the first who really used the battery in gilding. The methods both of gilding and silvering owe their present high state of perfection principally to the improvements of Elkington, Kuolz, and others.

The pieces to be gilded have to undergo three processes before gilding.

The first consists in heating them so as to remove the fatty matter which has adhered to them in previous processes.

As the objects to be gilded are usually of what is called *gilding metal* or red brass, which is a special kind of brass rich in copper, and their surface during the operation of heating becomes covered with a layer of cupric or cuprous oxide, this is removed by the second operation. For this purpose the objects, while still hot, are immersed in very dilute nitric acid, where they remain until the oxide is removed. They are then rubbed with a hard brush, washed in distilled water, and dried in gently heated sawdust.

To remove all spots they must undergo the third process, which consists in rapidly immersing them in ordinary nitric acid, and then in a mixture of nitric acid, bay salt, and soot.

When thus prepared, the objects are attached to the negative pole of a battery of 3 or 4 volts. They are then immersed in a bath of gold as previously described. They remain in the bath for a time, which depends on the thickness of the desired deposit. There is a great difference in the composition of the baths. That most in use consists of 1 part of gold chloride and 10 parts of potassium cyanide, dissolved in 200 parts of water. In order to keep the bath in a state of concentration, a piece of gold furnishes the positive electrode, which dissolves in proportion as the gold dissolved in the bath is deposited on the objects attached to the negative pole. The density of the current should not exceed $1/125$, that is, .008 ampere per square centimetre of the surface of the kathode.

The method which has just been described can also be used for gilding silver, bronze, german silver, &c. But other metals, such as iron, steel, zinc, tin, and lead, are very difficult to gild well. To obtain a good coating, they must first be covered with a layer of copper, by means of the battery and a bath of copper sulphate; the copper with which they are coated is then gilded as in the previous case.

The tint of the deposit is modified by adding solutions of copper or of silver to the gold bath; the former gives a reddish and the latter a greenish tint.

955. **Electrosilvering.**—What has been said about gilding applies exactly to the process of electrosilvering. The difference is in the composition of the bath, which consists of 2 parts of silver cyanide and 2 parts of potassium cyanide, dissolved in 250 parts of water. The positive electrode consists of a plate of silver, which prevents the bath from becoming poorer; its surface should be equal to the total surface of the objects to be silvered; the pieces to be silvered, which must be well cleaned, are attached to the negative pole. It may here be observed that these processes succeed best with hot solutions, and when the baths are old. The density of the current should be about $1/300$.

Knowing the weight of any given metal which is transported by unit quantity of electricity (940), it is easy to calculate the weight deposited in a given time by a current of known strength. Thus the current just specified, *i.e.* of $1/300$ ampere per sq. cm., would deposit 1.34 gramme of silver per square decimetre in an hour. A deposit of one ounce of silver on a square foot of surface gives a good coating; its thickness, $\frac{1}{100}$ inch or 0.03 mm., is about half that of thin writing paper.

956. **Electric deposition of iron, nickel, cobalt, and platinum.**—One of the most valuable applications of the electric deposition of metals is to what is called the *steeling* (*acierage*) of engraved copper plates. The bath required for this purpose is obtained by suspending a large sheet of iron, connected with the positive pole of a battery, in a trough filled with a saturated solution of sal-ammoniac; whilst a thin strip of iron, also immersed, is connected with the negative pole. By this means iron from the large plate is dissolved in the sal-ammoniac, while hydrogen is given off on the surface of the small one. When the bath has thus taken up a sufficient quantity of iron, an engraved copper plate is substituted for the small negative strip. A bright deposit of iron begins to form on it at once and the plate assumes the colour of a polished steel plate. The deposit thus obtained in the course of half an hour is exceedingly thin, and an impression of the plate thus covered does not seem different from one obtained from the original copper plate; it possesses, however, an extraordinary degree of hardness, so that a very large number of impressions can be taken from such a plate before the thin coating of iron is worn off. When, however, this is the case, the film of iron is dissolved off by dilute nitric acid, and the plate is again covered with the deposit of iron.

An indefinite number of perfect impressions may, by this means, be obtained from one copper plate, without altering the original sharp condition of the engraving.

The covering of metals by a deposit of *nickel* has of late come into use. The process is essentially the same as that just described. The bath used for the purpose can, however, be made more directly by mixing, in suitable proportions, salts of nickel with those of ammonia. The anode consists of a plate of pure nickel. A special difficulty is met with in the electric deposition of nickel, owing to the tendency of this metal to deposit in an uneven manner, and then to become detached. This difficulty is overcome by frequently removing the articles from the bath and submitting them to a polishing process.

Objects coated with nickel show a highly polished surface of the characteristic bright colour of this metal; the surface layer is moreover very hard and durable, and is little affected either by the atmosphere or even by sulphuretted hydrogen. A deposit of 2 grammes of nickel on the square decimetre represents a coating 0.023 mm. in thickness.

The deposit of *cobalt* has a brighter tint than that of nickel. Professor Silvanus Thompson uses a bath of cobalt sulphate or chloride, to which magnesium sulphate is added.

To obtain a deposit of *platinum*, the hydrate of this metal is dissolved in syrupy phosphoric acid, and this solution diluted with water so that it contains 1.2 to 1.5 per cent. of the hydrate. An anode of platinum or of carbon is used, and the strength of the bath is kept constant by the addition of the hydrate. Objects made of iron, nickel, and zinc must previously be coated with copper.

CHAPTER X

ELECTROMAGNETIC INDUCTION

957. **Induction by currents.**—We have already seen (762) that by *induction* is meant the action which electrified bodies exert at a distance on bodies in the natural state. Hitherto we have had to deal only with electrostatic induction; we shall now see that current electricity produces analogous effects.

Faraday discovered this class of phenomena in 1832, and he gave the name of *currents of induction* or *induced currents* to instantaneous currents developed in conductors under the influence of metallic conductors traversed by electric currents, or by the influence of powerful magnets, or even by the magnetic action of the earth; and the currents which give rise to them he called *inducing currents*.

A closed circuit, AB (fig. 965), contains a galvanometer G. A second circuit, CD, parallel to the first for a great part of the length, is connected with a battery V, and can be closed or broken or reversed at pleasure. The moment the circuit is closed a momentary current is produced in ABG, proceeding in the opposite direction—that is, from B to A. When the circuit is broken a momentary current is produced in the same direction as in CD—that is, from A to B.

The inductive action of a current at the moment of opening or closing may be more conveniently shown by means of two coils A and B (fig. 966), of which B consists of a great length of fine wire, and A is a coil of shorter and thicker wire, and of such dimensions that it can be placed inside B. For distinction A is called the *primary*, B the *secondary* coil. A is connected with a battery and B with a galvanometer. If A is placed inside B, the following phenomena are observed:—

i. At the moment of closing the primary circuit A, the galvanometer, by the deflection of the needle, indicates the passage in B of a current, *inverse* to that in A, that is, in the contrary direction; this is only

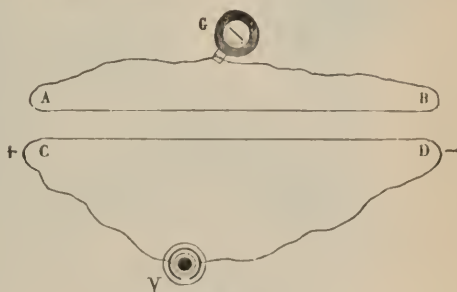

Fig. 965

instantaneous, for the needle immediately reverts to zero, and remains so as long as the inducing current passes through A.

ii. At the moment at which the battery circuit is broken, there is again produced in B an induced current instantaneous like the first, but *direct*, that is, in the same direction as the inducing current.

958. **Production of induced currents by continuous ones.**—Induced currents are also produced when the primary coil traversed by a current is approached to or removed from the secondary. The coil A (fig. 966) being traversed by a current, if it is suddenly placed in the coil B, the galvanometer indicates by the direction of its deflection the flow through it of an *inverse* current; this is only instantaneous; the needle rapidly returns to zero, and remains so as long as the small bobbin is in the large one. If it is rapidly

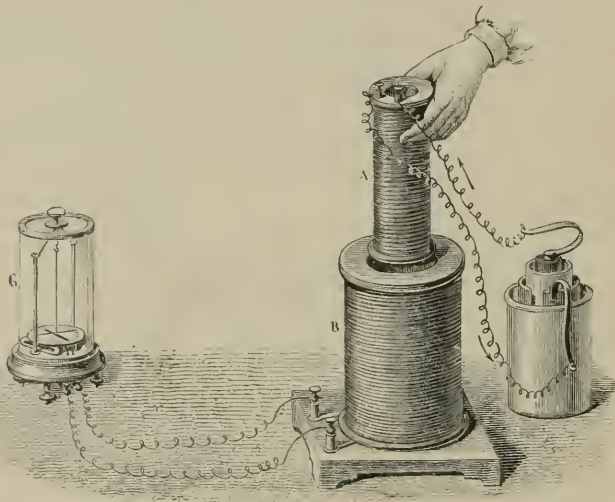

Fig. 966

withdrawn, the galvanometer shows that the wire is traversed by a direct current. If, instead of rapidly introducing or replacing the primary coil, this is done slowly, the galvanometer deflection is relatively small, and smaller, the slower the motion.

If, instead of varying the distance of the inducing current, its strength is varied—that is, either increased by bringing additional battery power into the circuit, or diminished by increasing the resistance—an induced current is produced in the secondary wire, which is inverse if the intensity of the inducing current increases, and direct if it diminishes.

959. **Induction by magnets.**—It has been seen (707) that the influence of a current magnetises a steel bar; in like manner a magnet can produce induced currents in metal circuits. Faraday showed this by means of a coil of wire, like that represented in fig. 967. The terminals being connected

with a galvanometer, a bar magnet is suddenly inserted in the bobbin, and the following phenomena are observed :—

i. At the moment at which the magnet is introduced, the galvanometer indicates in the wire the existence of a current, the direction of which is opposed to that which circulates round the magnet, considering the latter as a solenoid on Ampère's theory (894).

ii. When the magnet is withdrawn, the needle of the galvanometer, which has returned to zero, indicates the passage of a direct current. Care must be taken that the galvanometer is sufficiently far away for the bar magnet to have no direct action upon it.

The inductive action of magnets may also be illustrated by the following experiment : a bar of soft iron is placed in the above bobbin and a strong magnet suddenly brought in contact with it ; the needle of the galvanometer

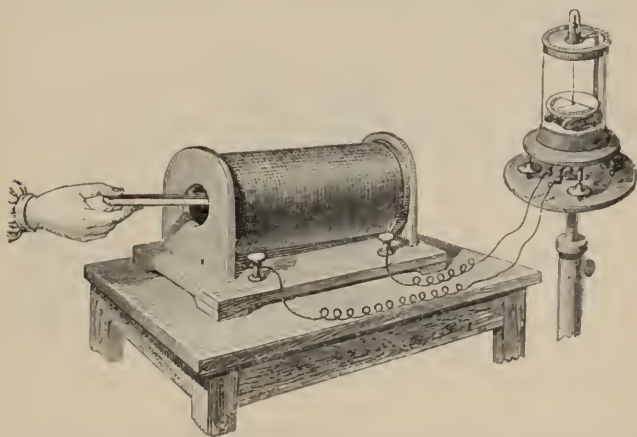

Fig. 967

is deflected, but returns to zero when the magnet is stationary, and is deflected in the opposite direction when it is removed. The induction is here produced by the magnetisation of the soft-iron bar in the interior of the bobbin under the influence of the magnet.

The same inductive effects are produced in the wires of a horseshoe electromagnet, if a strong magnet is made to rotate rapidly in front of the extremities of the wire in such a manner that its poles act successively by influence on the two branches of the electromagnet ; or also by forming two coils round a horseshoe magnet, and passing a plate of soft iron rapidly in front of the poles of the magnet ; the soft iron becoming magnetic reacts by influence on the magnet, and induced currents are produced in the wire alternately in different directions.

960. **General principles of induction.**—All cases of induction may be most conveniently explained by reference to the lines of force in the field due to a magnet or closed circuit. When the number of lines passing through any circuit or part of a circuit is altered, there is an induced

E.M.F. set up which produces a current if the circuit is closed. If the number of lines of force passing through the circuit is increased the current is in one direction ; if diminished, in the opposite direction. Mere motion of a conductor in a magnetic field will not give rise to any induced E.M.F. unless there is a change in the number of enclosed lines. Referring to fig. 966, when the coil A is in the position shown and the battery circuit is suddenly completed, the coil becomes a magnet and some of its lines of force pass through B ; hence an induced E.M.F. is set up in B, and as the secondary current is complete this E.M.F. produces a sudden flow of electricity through the circuit, which deflects the galvanometer needle. When A is thrust into B the number of lines passing through B is increased, and the needle, which has come to rest, is again deflected and in the same direction as before. If A is removed, or the circuit broken, the lines of force will diminish or disappear, and the throw of the galvanometer needle will be in the opposite direction. Should A contain an iron core, the induced currents are much more powerful, on account of the high permeability of iron, and the consequent large increase in the number of lines of force due to the current in A. With regard to the experiment illustrated in fig. 967, it is clear that the effect due to the approach and withdrawal of the bar magnet must be of exactly the same character as that exhibited with the

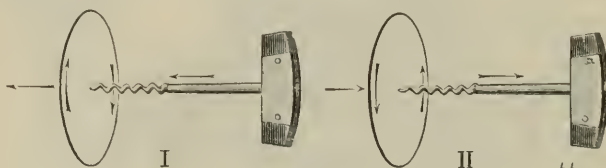

Fig. 968

solenoidal coil in fig. 966. The induced electromotive force, and consequently the throw of the galvanometer needle, depends in all cases upon the rate of change of the enclosed lines of force.

Various rules have been given for realising the direction of the induced E.M.F. Maxwell's rule is a convenient one to remember in dealing with a ring or coil ; it is as follows :—If when a corkscrew is used the direction of turning is called right-handed with regard to the direction in which the point moves, then if the direction of the lines of force through a coil corresponds to that of the point of the corkscrew, the induced E.M.F. is right-handed if the lines are diminishing in number and left-handed if increasing. Both figures (fig. 968) give the direction of the induced E.M.F. and current in the ring when the enclosed lines of force are diminishing. If a ring is moving parallel to itself in a uniform magnetic field, whether at right angles or parallel to the field, there is no alteration in the number of lines of force enclosed, and no current is produced in the ring.

In the case of a straight wire forming part of a closed circuit and moving in such a way as to cut the lines of force in the field, Fleming's rule is useful. It is as follows :—Suppose the forefinger and thumb of the right hand are in the same plane at right angles to each other, and the middle

finger is at right angles to both ; then if the thumb represents the direction of the motion, and the forefinger that of the lines of force, the middle finger will represent the direction of the electromotive force.

Another rule is the following :—Imagine a person identified with the wire and looking in the direction from which the lines of force are proceeding, so that they pass through him from front to back ; if he moves to his right the induced current will be from head to foot.

961. **Lenz's law.**—The direction in which the induced current flows was given by Lenz in a form which is known as Lenz's law, and is as follows :—When a current is induced in a conductor due to the motion in its neighbourhood of a magnet or of a coil carrying a current, its direction is such that the electrodynamic action of the induced current on the magnet or on the current in the coil is such as to oppose the motion. Thus (fig. 965) when CD carrying a current is made to approach AB, an inverse current is produced in the latter and opposite parallel currents *repel* each other. When

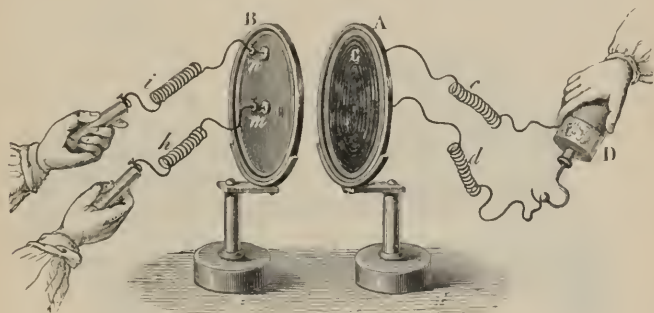

Fig. 969

CD is withdrawn from AB, a direct current is induced, and parallel currents in the same direction *attract* each other. In each case the electrodynamic action between the currents tends to stop the motion which gave rise to the induced current. In fig. 967, if a north pole is thrust into a coil the direction of the induced current will be such as to give north polarity to the near end of the coil ; that is, it will be anti-clockwise. If the primary and secondary coils A and B (fig. 966) are relatively at rest, but the current in A is started, or its strength increased, the effect on B is the same as if A were moved up to its present position from a considerable distance ; and, conversely, if the current in A is diminished or stopped, the effect on B is the same as if A were removed.

962. **Inductive action of the Leyden discharge.**—Fig. 969 represents an apparatus devised by Matteucci, for showing the development of induced currents by the discharge of a Leyden jar.

It consists of two glass plates about 12 inches in diameter, fixed vertically on the two supports A and B. On the anterior face of the plate A are coiled about 30 yards of thick copper wire C. The two ends of this wire pass through the plate, one in the centre, the other near the edge, terminating in

two binding screws, like those representd in m and n on the plate B. To these binding screws are attached two copper wires c and d , through which the inducing current is passed.

On the face of the plate B, which is towards A, is enrolled a spiral of finer copper wire than the wire C. Its ends terminate in the binding screws m and n , on which are fixed two wires, h and i , intended to transmit the induced current. The two wires on the glass plates are not only covered with silk, but each convolution is insulated from the next one by a thick layer of shellac varnish.

In order to show the production of the induced current by the discharge of a Leyden jar, one end of the wire C is connected with the outer coating, and the other end with the knob of the Leyden jar, as shown in the figure. When the spark passes, the electricity traversing the wire C acts by induction on the wire on the plate B, and produces an instantaneous current

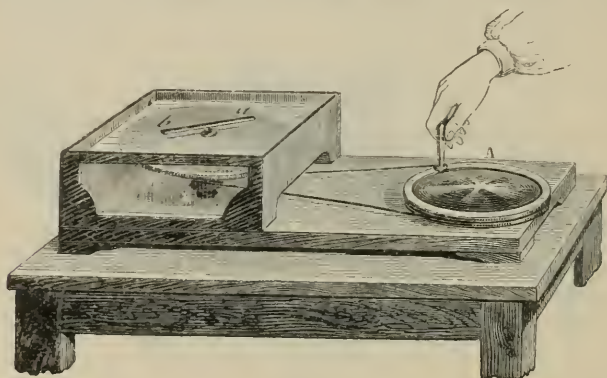

Fig. 970

in this wire. A person holding two brass handles connected with the wires i and h receives a shock, the intensity of which is greater in proportion as the plates A and B are nearer.

The experiment may also be made by simply twisting together two lengths of a few feet of gutta-percha-covered copper wire. The ends of one length being held in the hand, an electric discharge is passed through the other length.

963. **Inductive action of magnets on bodies in motion.**—Arago was the first to observe, in 1824, that the number of oscillations which a magnetised needle makes under the influence of the earth's magnetism, before it comes to rest, is very much lessened by the proximity of certain metallic masses, and especially of copper. This observation led Arago in 1825 to the discovery of an equally unexpected fact—that of the rotative action which a plate of copper in motion exercises on a magnet.

This phenomenon may be shown by means of the apparatus represented in fig. 970. It consists of a copper disc, M, movable about a vertical axis. On this axis is a small pulley, B, round which is coiled an endless cord, passing also round the pulley A. When this is turned by the hand, the disc M may

be rotated with great rapidity. Above the disc is a glass plate, on which is a small pivot supporting a magnetic needle, *ab*. If the disc is rotated with a slow and uniform velocity, the needle is deflected in the direction of the motion, and stops at an angle of from 20° to 30° with the direction of the magnetic meridian, according to the velocity of the rotation of the disc. But if this velocity increases, the needle is ultimately deflected more than 90° ; it is then carried along, describes an entire revolution, and follows the motion of the disc as long as it lasts.

Babbage and Herschel modified Arago's experiment by causing a horse-shoe magnet placed vertically to rotate below a copper disc suspended on silk threads without torsion; the disc rotated in the same direction as the magnets. The effect decreases with the distance of the disc, and varies with its nature. The maximum effect is produced with metals: with wood, glass, water, &c., it disappears. Lastly, the effect is enfeebled if there are non-conducting breaks in the disc, especially in the direction of the radii; but it is increased again if these breaks are soldered with any metal.

Faraday made a number of experiments on the phenomena presented by the motion of conductors in a magnetic field, and was the first to give an adequate explanation of them. They depend on the circumstance that in a magnetic field currents are induced in a solid mass of metal in motion. In Arago's experiment the magnet induces currents in the disc when the latter is rotated; and, conversely, in Babbage's experiment, when the magnet is rotated while the disc is primarily at rest. Now these induced currents, by their electrodynamic action, tend to destroy the motion which gave rise to them; they are simple illustrations of Lenz's law; they act in the same way as friction would do.

For instance, let *AB* (fig. 971) be a needle oscillating over a copper disc, and suppose that in one of its oscillations it goes in the direction of the arrows from *N* to *M*. In approaching *M* it develops induced currents in the copper in such a direction as, by their action on the pole *A*, to stop the motion which gave rise to them. If *A* is a north pole, the currents in the neighbourhood of *M* circulate anti-clockwise, while near *N*, which it is leaving, they have a contrary direction. Tracing the currents due to the south pole *B* in the same way, it will be seen that in the half of the copper disc to the left the currents induced by the motion of the needle have a clockwise, and in the right half an opposite direction, and their effect on both sides of the needle tends to stop it. The damping effect depends upon the strength of the induced currents, and therefore on the conductance of the plate. If a radial slit is made in the plate the circulation of the induced currents is impaired, and the effect diminished.

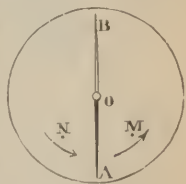

Fig. 971

The damping effect of the copper bowl of a compass on the needle is explained by the electrodynamic action between the needle and the currents it induces in the copper as it moves.

If in Arago's experiment the disc is moving from *N* to *M* (fig. 971), *N* approaches *A* and repels it, while *M*, moving away, attracts it; hence the needle moves in the same direction as the disc.

Faraday suspended a cube of copper to a twisted thread, which was

placed between the poles of an electromagnet (fig. 1017). When the cube was left to itself it began to spin with great velocity, but stopped the moment a strong current was passed through the electromagnet. In fig. 972 MM

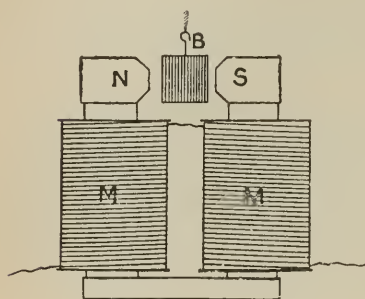
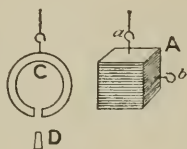

Fig. 972



are the coils wound on the two limbs of an electromagnet, and N and S are soft-iron pole pieces. If Faraday's cube, instead of being solid, is made up of a number of thin square plates of copper separated by varnished paper

(fig. 972, A, B), and has two hooks attached, so that it can be suspended between the poles of the electromagnet with the plates either vertical or horizontal, it will be found that the magnetic field has no action when the suspension is by the hook α , for then, as the cube spins, the plates, being horizontal, do not cut the lines of force. But if the plates are vertical, the motion of the cube is at once arrested when the current is switched on.

In fig. 972 C is a copper ring with a saw-cut at the bottom, which can be filled in with a copper wedge, D. If C is spun between the poles of the electromagnet, the magnetic field has no effect on it unless the wedge is introduced, for otherwise there can be no induced current in the ring; the sides of the gap merely become, alternately, positively and negatively charged.

We are now in a position to explain the dead-beat action of a suspended coil galvanometer (897). If the coil is wound on an aluminium frame, we have a complete metallic circuit in a strong magnetic field, and any motion of the frame must cause the development of induced currents, which tend to stop its motion. It must be remembered that the damping force depends upon the strength of the induced current, and this varies inversely as the resistance of the circuit; and as aluminium is a very good conductor, the damping action is considerable. Sometimes the suspended coil is wound on a paper or pasteboard frame; in these cases there will be no electromagnetic damping if the circuit of the coil is open, and the damping will be a maximum when the galvanometer is short-circuited.

964. **Heat developed by the motion of a conductor in a magnetic field.**—We have seen in Arago's experiment that a rotating copper disc acts at a distance on a magnetic needle, communicating to it a rotatory motion, and that a cube of copper, rotating with great velocity, is suddenly stopped by the influence of the field between the poles of a strong magnet. It is clear that, in order to prevent the rotation of the needle or of the copper, a certain mechanical force must be applied for the purpose of overcoming the resistance which arises from the inductive action of the magnet.

This was shown in a remarkable experiment made by Foucault by means of the apparatus represented in fig. 973. It consists of a powerful electro-magnet fixed horizontally on a table, and provided with soft-iron pole-pieces, A and B. A copper disc, D, 3 inches in diameter and a quarter of an inch thick, partly projects between the pieces A and B, and can be rotated by means of a handle and a series of toothed wheels with a velocity of 150 to 200 turns in a second.

So long as the electric circuit of the electromagnet is broken, very little resistance is experienced in turning the handle, and when once it has begun to rotate rapidly, and is left to itself, the rotation continues in virtue of the acquired velocity. But when the current is made to pass, the disc stops almost instantaneously; and if the handle is turned considerable resistance is felt. If, in spite of this, the rotation is continued, the energy spent is transformed into heat, and the disc becomes heated to a remarkable extent.

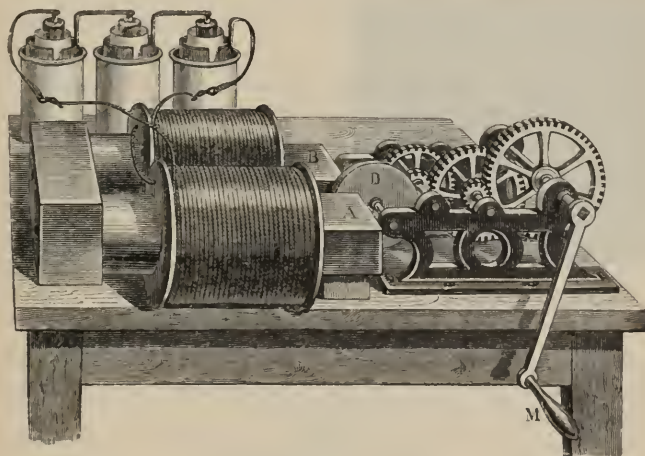

Fig. 973

In an experiment made by Foucault the temperature of the disc rose from 10° to 61° , the current being produced by three Bunsen cells; with six the resistance was such that the rotation could not long be continued. The currents thus produced in solid conductors and converted into heat are often spoken of as *Foucault* or *eddy currents*.

Such currents are of constant occurrence in magneto- and dynamo-electric machines, and weaken their efficiency, because some part of the work expended is required for their production and maintenance; and also because, being converted into heat, they increase the internal resistance of the machine.

These effects are got rid of or greatly diminished by forming the armature cores of insulated iron wires or thin plates parallel to the axis; they are thus at right angles to the direction in which Foucault currents tend to form. This does not, however, prevent the heating effects due to hysteresis (907).

965. **Electromotive force in absolute measure.**—In fig. 974, let H represent the direction of the lines of force in a uniform magnetic field, and let the conductor AB be moved at right angles to the field and parallel to itself; experiment then shows that an E.M.F. is set up *the direction of which is from B to A*.

If the conductor AB is free, electrostatic charges are produced at the ends, positive at A and negative at B , which tend to neutralise each other, and are maintained by the E.M.F. which had produced them, and which counterbalances this tendency.

Suppose the ends of the conductor AB joined by a wire which is outside the field, and therefore not subject to induction. This would be the case, for instance, if AB is moved at right angles to the line joining the poles of a



Fig. 974

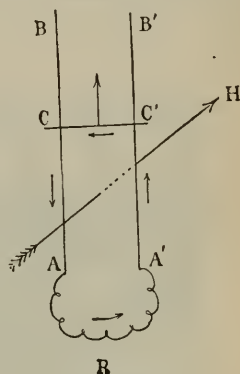

Fig. 975

powerful horseshoe magnet, while the ends are connected by wires with a galvanometer at a distance; a current is then produced as long as the motion continues, the direction of which is $BAA'B'$.

If in the above case l is the length of the conductor, v the velocity with which it is moved across the lines of force, and H the intensity of the field, the electromotive force $e = Hlv$. For unit field, and a velocity of 1 cm. per second, the E.M.F. per centimetre of conductor moved is 1 C.G.S. unit.

Hence the unit electromotive force on the C.G.S. system is defined as that produced in a straight wire 1 centimetre long when moving with a velocity of 1 cm. per second in a direction at right angles to its own length and to the lines of force in a uniform magnetic field of unit intensity.

Suppose, for instance, we have two parallel horizontal metal rails $AB, A'B'$ (fig. 975), with a bar CC' laid across, the ends AA' being connected with a galvanometer. The direction of the field represented by the arrow H is from front to back. If the bar CC' is a metre long and moves at right angles to its own length and to the direction of the field with a uniform velocity of 20 metres per second, then, since the vertical intensity of the earth's field is 0.444 (736), the induced E.M.F. will be $100 \times 0.444 \times 2000 = 8.88 \times 10^4$ C.G.S. units = 8.88×10^{-4} volts, since 1 volt = 10^8 abs. units, and if the total resistance of the circuit is 1 ohm, the current $C = .000888$ ampere or 888 micro-amperes.

An illustration of a method of producing a steady current by the motion of a conductor in a magnetic field is afforded by *Faraday's disc* (fig. 976). It is a disc of metal rotated about a metallic axis passing through its centre and perpendicular to its plane. Suppose two brushes, one B, pressing against the axis, and the other A, against the edge of the disc, are connected by a wire, and suppose the disc be made to rotate uniformly in a uniform magnetic field H, whose direction is perpendicular to the disc.

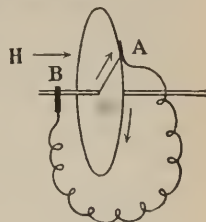

Fig. 976

Any radius of the disc cuts in each revolution SH lines of force, where S is the area of the disc. Hence if T is the time of one revolution, $\frac{SH}{T}$ is equal to the number of lines cut per second, and therefore equal to the electromotive force, and the induced current is $C = \frac{SH}{TR}$, where R is the total resistance in the circuit.

We have already seen (891) that if a current is passed through the disc from axis to circumference, as shown in fig. 887, the disc rotates in a direction opposite to that of the arrow.

966. **Induction by the action of the earth.**—Faraday discovered that terrestrial magnetism can develop induced currents in conductors in motion. He first proved this by placing a solenoidal coil (such as A, fig. 966) with its length parallel to the dipping-needle; on turning this helix 180° about an axis perpendicular to its length in its middle, he observed that at each turn a galvanometer connected with the two ends of the helix was deflected. The apparatus depicted in fig. 977, and known as *Delezenne's circle*, serves well

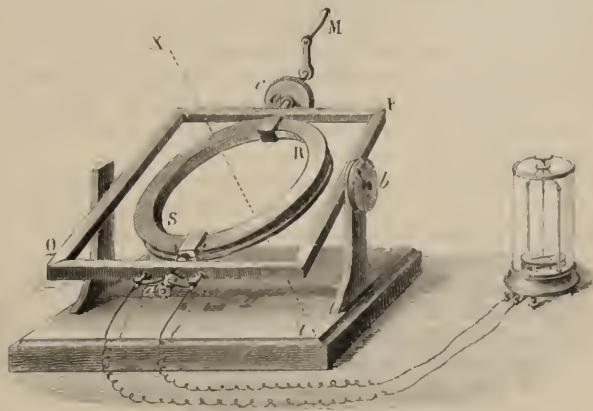

Fig. 977

for showing the currents produced by the inductive action of the earth. It consists of a wooden ring, RS, about a foot in diameter, fixed to an axis, oa, about which it can be turned by means of a handle, M. The axis oa is

itself fixed in a frame PQ, movable about a horizontal axis. By pointers fixed to these two axes the inclination towards the horizon of the frame PQ, and therefore of the axis oa , is indicated on a dial, b , while a second dial, c , gives the angular displacement of the ring. This ring has a groove in which is coiled a great length of insulated copper wire. The two ends of the wire are joined up with brass plates on the insulated axis, whence by means of springs and binding screws they are connected with a ballistic galvanometer.

If the plane of the coil RS, being originally at right angles to the lines of the earth's magnetic field, that is, to the direction of the dip needle, is then suddenly turned through any angle, the needle of the galvanometer shows the passage of a momentary current.

At first the coil is full of lines of force, the flux being AY, where Y denotes the earth's total magnetic force, and A the mean area (in sq. cm.) of one turn of wire. When the coil has been rotated through 90° , the magnetic flux has been diminished to zero; hence by Maxwell's rule (960) as we look down upon the coil in fig. 977 a direct or right-handed current has been developed in it. As the rotation is continued from 90° to 180° the induced current *in the wire* has the same direction as before, for although as we look down it appears to be reversed it must be remembered that the coil itself is reversed in position, the part marked S being now on the right and that marked R on the left. Thus, the current in the coil is throughout the rotation from 0° to 180° in the same direction, say, positive. Similarly from 180° to 360° the current is in the opposite direction, or negative. In turning the coil through 180° the total charge in the number of enclosed lines of force is $2AY$.

Placing now the coil in the position in which its plane is perpendicular to the dip needle, turn it rapidly through 180° , so rapidly that the operation is completed before the needle of the galvanometer has sensibly moved. The rush of electricity through the galvanometer acts like the discharge of a condenser, and causes a throw of the needle proportional to the quantity of electricity which has passed through it; that is $Q = kd$, where Q is the quantity of electricity, d the throw of the needle, and k a constant. The throw of the needle is therefore proportional to Y , the total force of the earth's magnetism.

Let us examine this a little more closely. Suppose that the coil, consisting of n turns of wire, rotates through a small angle, θ , in a short time, t , and that the consequent change in the number of lines passing through the coil is u ; then u/t is the rate of change, and, since each turn of wire cuts the lines, nu/t is by definition equal to the instantaneous E.M.F. generated. Call this electromotive force e , then $e = nu/t$, or $nu = et$. The instantaneous current is equal to the instantaneous electromotive force divided by the resistance of the circuit; if this latter is R , and c is the instantaneous value of the current, $c = e/R$, hence $ct = et/R = nu/R$. In this equation ct is the quantity of electricity passing through the circuit during the short time t . If we take the sum of these quantities during the operation of turning the coil through 180° , we obtain the total quantity of electricity which has passed through the circuit, and since $\Sigma ct = Q = \Sigma nu/R = nN/R$, where N is the total change in the number of lines threading through the coil. But this is known, for it is equal to $2AY$, the letters having the meanings assigned

above. Thus Q is known when we know the resistance, R , of the circuit, and hence the constant k can be determined.

It is convenient to have a unit in which to express the product et , which, as we see above, is of the nature of a number of magnetic lines of force, or a magnetic flux. The name given to the *practical* unit is a *maxwell*, or more shortly a *max*. A maxwell is the product of a volt and a second; it is related to an E.M.F. in the same way as a coulomb is related to an ampere. An E.M.F. of 1 volt applied to a circuit of unit resistance gives rise to a steady flow of 1 ampere; a maxwell applied to a circuit of unit resistance causes 1 coulomb of electricity to flow through it.

If the axis of rotation, oa , is vertical, only the horizontal component of the earth's magnetism can act, and if then the coil is sharply turned from 0° to 180° , the throw of the needle is a measure of the horizontal component H . Similarly, if the axis is horizontal and in the magnetic meridian, only the vertical component V acts, and is thus measured by the throw of the needle.

Hence, from two such sets of observations we may determine the magnetic dip in any place, for $\tan i = \frac{V}{H}$, where i is the inclination or dip (733). If great sensitiveness is required, a ballistic reflecting galvanometer must be used in place of that illustrated in fig. 977.

The arrangement a on the frame is made to act as a commutator (986) adjusting the opposed currents so that they are in the same direction. Hence when the coil RS is rapidly rotated with uniform velocity the galvanometer indicates a steady unidirectional current.

967. **Self-induction. Extra current.**—If a closed circuit traversed by a current is broken, a scarcely perceptible spark is obtained if the wire joining the two poles is short. Further, if the observer himself forms part of the circuit by holding a pole in each hand, no shock is perceived unless the current is very strong. If, on the contrary, the wire is long, and especially if it makes a great number of turns so as to form a coil with very close folds, and still more if a soft-iron bar is inserted in the coil, the spark, which is inappreciable when the circuit is closed, acquires a great intensity when it is opened, and an observer who forms part of the circuit receives a shock which is the stronger the greater the number of turns.

Faraday, who discovered these phenomena, showed that they were effects of induction; not only does a current act inductively on a neighbouring circuit, but each winding acts inductively on the next windings of its own circuit, both on making and on breaking the circuit, by a process which is called *self-induction* or *inductance*. On making the circuit, each winding induces in the neighbouring ones a current in the opposite direction to its own—that is, an *inverse current*. This, which Faraday called the *extra current on making* or the *inverse extra current*, diminishes the intensity of the principal current; the effect is that the current on making does not at once attain its full strength; starting at zero its intensity gradually rises, and only reaches that strength after a time which, though short, is appreciable, more especially when an electromagnet with a great number of coils forms part of the circuit.

When the circuit is broken each winding acts inductively on those near

it, producing a current in the same direction as its own, and forming, as it were, a prolongation of it, but of far higher electromotive force; since the electromotive force depends upon the rapidity with which the lines of force are removed from the circuit, and this may be very great.

To show the existence of this current on breaking, Faraday arranged the experiment as seen in fig. 978. Two wires from the poles E E' of a battery B are connected with the terminals D and F of an electromagnet. On the

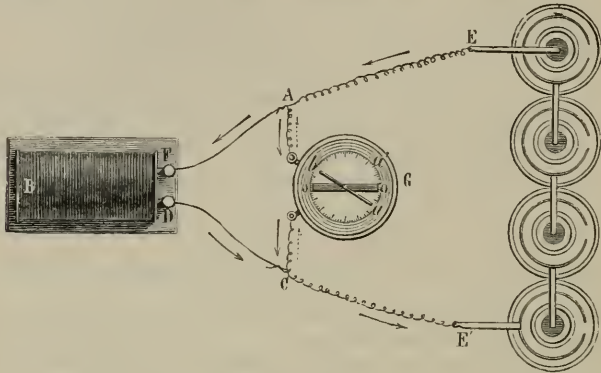

Fig. 978

path of the wires at the points A and C are two other wires, which are connected with a galvanometer, G. Hence the current from the pole E branches at A into two currents, one of which traverses the galvanometer, the other the electromagnet, and both join the negative pole E'.

The needle of the galvanometer, being then deflected from G to a' by the current which goes from A to C, is brought back to zero, and kept there by a stop which prevents it from turning in the direction Ga' , but leaves it free in the opposite direction. On breaking contact at E, it is seen that the moment the circuit is open the needle is deflected in the direction Ga ; showing a current contrary to that which passed during the existence of the battery current—that is, the current from C to A. But the battery circuit being broken, the only remaining one is the circuit AFBDCA; and since in the part CA the current goes from C to A, it must traverse the entire circuit in the direction AFBDC—that is, the same as the principal current. This is the *extra current on opening*, or *direct extra current*, or *self-induction current*.

Faraday pointed out the analogy of the effects of self-induction to those of the inertia of liquids, as in the hydraulic ram, for instance. A flow of water in a pipe can neither be suddenly established nor suddenly stopped, and if a stopcock in the pipe is suddenly turned off a shock is produced due to the energy of the fluid in motion (152). But while the effects of the hydraulic ram are lessened by the bends in a pipe, the extra current is far more marked in a coil than in a straight wire of the same length.

To observe the direct extra current the conductor on which its effect is to be tried may be introduced into the circuit, by being connected in

any suitable manner with the binding screws A and C (fig. 978) in the place of the galvanometer. It can thus be shown that the direct extra current gives violent shocks and bright sparks, decomposes water, melts platinum wires, and magnetises steel needles.

Faraday's experiment may be modified by substituting a small glow-lamp for the galvanometer G. The voltage of the battery must be adjusted to make the lamp just glow when a steady current is flowing. When the main circuit is suddenly broken the lamp glows brilliantly owing to the large E.M.F. developed in the electromagnet by the sudden disappearance of the lines of force through it.

The shock due to self-induction may be tried by attaching wires connected with the poles of a single Grove or storage cell to two files, which are held in the hands. On moving the point of one file over the teeth of the other, a series of shocks is obtained, due to the alternate opening and closing of the circuit. In this experiment the hands should be moistened with water to diminish the resistance of the skin.

968. **Coefficients of self- and mutual-induction.**—The *coefficient*, L , of *self-induction* or *inductance* of a circuit is defined as being numerically equal to the number of lines of force enclosed by the circuit when the latter is traversed by unit current. Thus, LC denotes the number of enclosed lines when the current is C ; L is a constant so long as the form and arrangement of the circuit remain the same, and so long as it contains no iron. The rate of change of LC with time is equal to the electromotive force of self-induction. Suppose the current in a circuit to be gradually diminishing; then the number of enclosed lines is diminishing also, and an *E.M.F. of self-induction* is set up which opposes the weakening of the current, and is equal to the rate of disappearance of the lines of force. On the other hand, if the current is rising, the E.M.F. of self-induction, which is equal to the rate at which the lines of force increase, opposes the rise. If the change in the current is 1 ampere per second, and the induced E.M.F. is 1 volt, then L , the coefficient of self-induction, is unity and is called a *henry*.

Suppose there are two neighbouring circuits, such as the two coils shown in fig. 966; each of them when traversed by a current will be penetrated by a magnetic flux, some of the lines of which will traverse the other circuit. When the currents in the two circuits are equal, the number of lines of force due to either which pass through the other is the same. This number of lines, when each current is 1 ampere, is called the *coefficient of mutual induction*, or the *mutual inductance* of the two circuits, and is denoted by M . M , like L , the coefficient of self-induction, is expressed in henrys. The mutual inductance of the circuits is 1 henry if an E.M.F. of 1 volt in one of them results from a variation of the strength of the current in the other at the rate of 1 ampere per second.

In the case of a coil of wire of many turns the coefficient of self-induction varies as the square of the number of turns.

A striking experiment on self-induction is to introduce a coil of wire into the circuit of an alternate current dynamo machine (985) feeding incandescent lamps, and, when the current is flowing, to insert suddenly a thick iron bar into the coil. The self-induction is at once greater, and more lines of force pass through the coil. The current has to supply the energy necessary

for this increase, and for a time falls in strength; this is seen by the diminished light in the lamps.

969. **Growth of a current and energy of the circuit.**—When a circuit is completed the current does not instantaneously attain its full and final value, since the E.M.F. of the battery is opposed by that due to the self-induction of the circuit. If $C \left(= \frac{E}{R} \right)$ is the final value of the current, the *actual*

current at any time, t , after the circuit is completed, will depend upon the time and also upon the self-induction. Mathematical analysis shows that

it is equal to $C \left(1 - \epsilon^{-\frac{R}{L}t} \right)$, where ϵ is the base of Napierian logarithms,

or 2.71828; so that $C = \epsilon^{-\frac{R}{L}t}$ is the amount by which the current falls

short of its full value at any time, t . This last expression is equal to zero only when t is infinite, but it diminishes as a rule with great rapidity, and becomes sensibly equal to zero for a comparatively small value of t . When

$t = \frac{L}{R}$, the value of the current is $C (1 - \epsilon^{-1})$, or $\cdot 634 \times C$. The quantity

L/R is called the *time-constant* of the circuit; it is the time which must elapse from the moment of completing the circuit before the current attains to a value $\cdot 634$ (or nearly two-thirds) of its full strength. The time-constant is small if the inductance of the circuit is small in comparison with its resistance. On the other hand, in a circuit like that of a transformer, when the inductance is high and the resistance relatively small, the time-constant may be 5 or 10 seconds, or more.

Since $L/R =$ a time, and R is of the nature of a velocity, $L = Rt$ is a length. If $R =$ the C.G.S. unit of resistance, viz. a velocity of 1 centimetre per second, and $t = 1$ second, L is equal to 1 centimetre, and this is the C.G.S. unit of self-induction. But if $R = 1$ ohm $= 10^9$ cm./sec., $L = 10^9$ centimetres. Professors Ayrton and Perry proposed to call this unit a *secohm*, since it may be regarded as the product of a second and an ohm. Since 10^9 cm. is the length of a quadrant of a great circle of the earth, Sir Oliver Lodge proposed to call the practical unit of self-induction a *quadrant* (or briefly, a *quad*). Neither of these suggestions has been adopted; by international agreement the practical unit of self-induction is called a *henry*, after Professor Henry, of Princetown, New Jersey.

Ohm's law is not applicable during the variable state which exists immediately after the completion of the circuit, for, until the current has attained its full value, only a part of the energy derived from the battery appears in the form of heat in the circuit. The remainder has been spent in establishing the magnetic field surrounding and penetrating the circuit, and remains in the form of potential energy in the field. It may be proved that this energy is equal to $\frac{1}{2}LC^2$. Hence, if E is the E.M.F. of the battery and Q the quantity of electricity which has passed through the circuit during any time t , $EQ = C^2Rt + \frac{1}{2}LC^2$, C^2Rt being that part of the energy which is exhibited in the form of heat in accordance with Joule's law, and which increases with the time. The remainder, $\frac{1}{2}LC^2$, depends only on the self-induction and the value of the current, and is independent of time when C has become constant; in other words, energy is not required to maintain

the magnetic field when it has once been established. When the circuit is broken the energy expressed by $\frac{1}{2}LC^2$ is given back to it, and causes the direct extra current and the brightness of the spark on breaking.

970. **Resistance in absolute measure.**—The first determination of the resistance of a conductor in absolute measure was made by a committee of the British Association in 1863. Before that time resistances were expressed in arbitrary units, such, for example, as the resistance of 100 yards of copper wire, or of 1 metre of platinum wire, of specified diameter. As there was no common standard, it was difficult to compare results obtained by different observers at different times or in different countries. Hence the desirability of finding a standard which should be the same at all times and places, and should be independent of the properties of any particular material. Now, for a steady current, we have by Ohm's law $C = E/R$, and to determine R in absolute measure we must have C and E in absolute measure. A current may be measured in absolute measure by a tangent galvanometer (837), when the strength of a magnetic field is known; and an electromotive force may be determined by a method similar to that of article 965, but here, also, it is necessary to know the value of the magnetic field in which the conductor moves. In the British Association experiment C and E were measured, and the arrangement was such that the unknown magnetic fields were one and the same, and cancelled each other. The experiment consists in rotating a circular closed coil of wire, of resistance R , to be determined, about a vertical diameter. The current induced in the coil, due to cutting the horizontal lines of the earth's magnetic field, is an alternating one, its strength varying as the ordinate of a sine curve (59), but to an observer contemplating the rotating coil from the east or west side of it, the current, though varying in amount, will always be in the same direction. For instance, if the coil as seen from above is spinning right-handedly, the induced current ascends in that part of the coil which is towards the north. A compass needle suspended at the centre of the coil will be deflected

exactly as in the case of a tangent galvanometer. Hence $C = \frac{Hr}{2n\pi} \tan \theta$,

where H is the horizontal force, r the mean radius of the coil, n the number of turns, θ the deflection of the needle, and C the *mean* current in absolute measure. The mean current is equal to the mean electromotive force divided by the resistance. Now, as the coil turns from 0° to 90° , the enclosed lines of force change by nAH , where A is the area of one turn; in one revolution the change is $4nAH$, and if T is the periodic time of revolution, the mean induced E.M.F. is $4nAH/T$, and the current is $4nAH/TR$.

Neglecting the effects of self-induction, and equating the two expressions for the current, we have :

$$\frac{Hr}{2n\pi} \tan \theta = \frac{4nAH}{TR}$$

$$\therefore R = \frac{8n^2A}{rT \tan \theta}$$

In this expression n^2 and $\tan \theta$ are mere numbers, A/r is a length, and hence R is equal to a constant multiplied by a velocity. The resistance

of the coil is, therefore, expressed in terms of a velocity, and the unit resistance must be a resistance of 1 centimetre per second. The practical unit is 10^9 cm./sec. (850).

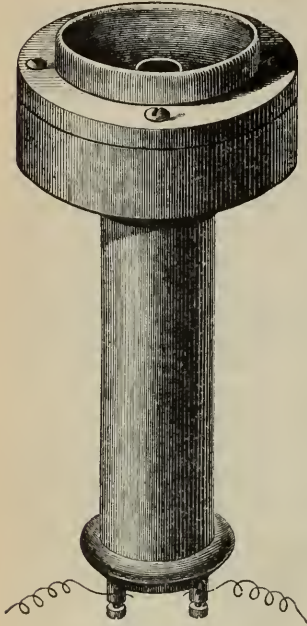

Fig. 979

It consists essentially of a steel magnet, of about 4 inches in length by half an inch in diameter, enclosed in a wooden case. Round one end of this magnet is fitted a thin flat bobbin, BB, of fine insulated copper wire. For a magnet of this size a length of 250 metres of No. 38 wire, offering a resistance of 350 ohms, is well suited.

971. **The telephone.**—To the number of instruments depending on induction may be added the *telephone*, an instrument devised for the transmission of articulate speech, which is equally remarkable for the surprising character of the results which it produces, and for the simplicity of the means by which they are produced. Fig. 979 represents a perspective, and fig. 980 a section of Graham Bell's telephone.

The ends of this coil pass through longitudinal holes, LL, in the case, and are connected with the binding screws CC. In front of the magnet, and at a distance which can be regulated by a screw, but which is something less than a millimetre, is the essential feature of the instrument, a diaphragm, D, of soft iron, called the *tympanum*, not much thicker than a sheet of stout letter-paper. This diaphragm is screwed down by the mouth-piece E, which is similar to, though somewhat larger than, that of a stethoscope.

Two such instruments are connected by wires. Each can be used either as sender or receiver, though in actual practice it is more convenient for each operator to have two telephones, one of which is held to the ear, while the

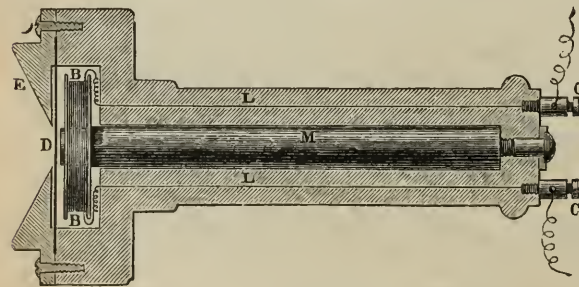

Fig. 980

other is used for speaking into; the latter being larger and more powerful than the receiver.

The action of the instrument depends on the production and variation of electric currents, in the circuit consisting of the two instruments and the connecting wires, by variation of electromotive force, the resistance in

the circuit being constant. Suppose the end of the magnet M, near the tympanum D, to be a north pole; D, being in the field of M, is magnetised, having south polarity at the centre and north polarity round the circumference. So long as D is at rest, the magnetic flux through the coil B is constant; if \bar{D} moves towards the magnet the flux increases, giving rise to an induced E.M.F. in the coil, which drives a current (say, negative) round the circuit; similarly, when D returns, a positive current passes, due to the diminution in the number of lines of force enclosed by B, and when D oscillates in a periodic manner, a regular succession of positive and negative currents passes into the line and to the receiving instrument at the other end. Here the field is alternately strengthened and weakened, causing the tympanum to vibrate in exact correspondence with that at the sending station. Suppose the simple note C, of 256 vibrations, to be sounded in front of the instrument; the air particles oscillate, sound waves reach the tympanum, which is set in vibration owing to the successive increase and diminution of pressure on its front surface, and 256 current waves traverse the circuit. It might be supposed that a tympanum capable of vibrating 256 times a second would be unable to respond to a note of higher or lower pitch, but it is one of the most remarkable properties of this very simple instrument that the tympanum can vibrate rapidly or slowly equally well.

The variety of modes of vibration exhibited by a Chladni plate (284), depending on the places at which it is bowed and damped, helps us to understand this; but the complexity of the motion of a telephone plate must be vastly greater than anything exhibited by a Chladni plate. For it must be remembered that the tones of the human voice are not simple, but each is compounded of a fundamental and a number of superposed harmonics, and as all the characteristics of the voice are faithfully reproduced at the distant instrument, it follows that each tympanum takes up all the component vibrations of a complex tone.

Though the reproduction of the sound in the receiving instrument is perfect as far as articulation is concerned, it is considerably enfeebled, as might be expected. The sound has something of a metallic character, appearing as if heard through a long length of tubing, while it faithfully reproduces the characteristics of the person speaking. It does not result from a series of sharp and distinct makes and breaks, as the circuit is never broken, but there is a continuous rise and fall of current, corresponding, in every gradation and inflection, to the motion of the air agitated by the speaker.

The exact reproduction by one of the instruments of the note sounded into the other is illustrated by the following experiment:—Support two telephones horizontally, any distance apart; connect them in circuit and remove from each its mouth-piece and tympanum, replacing them by steel tuning-forks of exactly the same frequency mounted on resonance boxes (251). If the tuning-forks are adjusted so that one prong of each is within about a millimetre of the end of the corresponding magnet, M (fig. 980), and one of them, A, is sounded by a violoncello bow, the second, B, will at once begin to vibrate. If, however, A is loaded with a little wax, and its frequency thereby slightly lowered, B will no longer respond. The vibration of B can be *seen*, by placing in contact with its prong a small pellet of shellac,

suspended by a fine thread. As B is set in vibration the pellet is jerked off, and as it returns receives another impulse, and so on. If the forks are not exactly in unison the pellet remains quiescent.

Various attempts have been made to improve the loudness of the sounds produced in the telephone, by varying the form of the various parts, and using more powerful magnets of horseshoe and circular forms; *Ader's* telephone, which is largely used in France, is constructed with a circular horseshoe magnet.

The amplitude of the vibration of the disc is extremely small; according to Bosscha it must be about the $\frac{1}{20}$ of the wave-length of yellow light (651).

This extreme delicacy of the telephone is its drawback to speaking through ordinary telegraph circuits. The currents in adjacent wires, the vibration of the posts and of the insulators, or the passage of a cart over the streets, acts by induction on the telephone circuit, and overpowers its indications. When a telephone circuit was placed at a distance of 20 metres from a well-insulated line, through which signals were sent by means of a battery of a few cells, sounds were distinctly heard in the telephone. Speaking under such circumstances is like speaking in a storm. The powerful currents used for systems of electric lighting produce such a roar in an adjacent telephone circuit that it is impossible to speak through the telephone. The only effective way of diminishing the inductive action of adjacent systems is to have two insulated wires close to each other, forming a *loop circuit*. They are thus at the same distance from the inducing circuit, and, as one of the wires is used for going and the other for returning, the similar influences must be in opposite directions, and therefore neutralise each other.

Iron wires present a special difficulty in telephoning through long distances. Telephone currents are alternating ones, and the self-induction of the circuit modifies both their strength and their character. This self-induction is more pronounced the longer the circuit, and with iron it is 300 times as strong as with copper. Hence for long distances a loop circuit of copper or bronze wire is used, and with such circuits it is possible to telephone through very long distances. In America, New York and Chicago, 930 miles apart, are in telephonic communication; the greatest distance in Europe is from London to Marseilles, *via* Paris.

Telephones have been constructed in which the thin iron plate is replaced by a thicker one, or by an unmagnetic one; or if the telephone is held close to the ear, the plate can be dispensed with altogether. In the latter two cases the sounds are perceived only when the spiral surrounding the magnet can vibrate with it.

A telephone may be constructed with a rod of soft iron instead of a magnet; when the rod is held in the line of dip, and the mouth-piece is sung into, the sounds are reproduced.

From its extreme sensitiveness, being perhaps the most delicate galvanoscope we possess, the telephone has become of great service in scientific research. It may be used instead of a galvanometer in a Wheatstone's bridge, in which case the cell is replaced by an intermittent source or by the secondary of a very small induction coil. The resistances in the arms of the

bridge are modified until the sound heard in the telephone disappears or is reduced to a minimum. The method is useful for the measurement of liquid resistances, as, with an alternating source, there is practically no polarisation (942).

Dolbear has constructed a telephone in which the electrostatic action of currents is used. It consists of two circular flat discs of metal rigidly fixed to each other in an insulated case of ebonite. One of the discs is in metallic connection with the line wire, in which are a battery and an induction coil; in this way, while one disc is electrified positively, the other is negatively electrified by induction, and if the current is varied by speaking through a transmitter in the circuit their varying effects are faithfully reproduced, and reappear as sound vibrations on the receiver.

972. **The microphone.**—When the wires of an electric circuit, in which is interposed a telephone, are broken, and rest loosely on each other, sounds produced near the point of contact are reproduced and magnified in the telephone. The *microphone*, invented by Professor Hughes, depends on this fact; its arrangement may be greatly varied; one of the simplest and most convenient forms is that represented in fig. 981. A piece of thin wood is

fitted vertically on a base of the same material; two small rods of gas carbon, C C, about $\frac{1}{8}$ of an inch thick, are fixed horizontally in the upright; by means of binding screws, they are in metallic connection with the wires of a circuit in which are a small battery and a telephone; and in each of them is a cavity. A third piece, D, of the same material, and about one inch long, is pointed at each end, one of which rests in the lower cavity, while the other pivots loosely in the upper one. When a watch is placed on the base B, its ticking is heard in the telephone with surprising

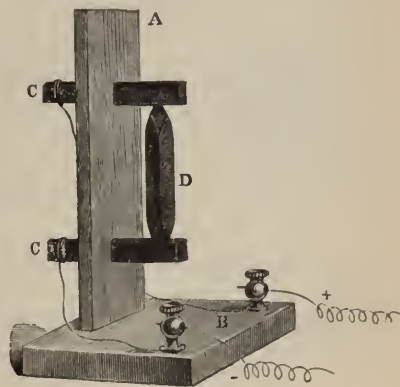

Fig. 981

loudness; the walking of a fly on the base suggests the stamping of a horse; the scratching of a quill, the rustling of silk, the beating of the pulse, are perceived in the telephone at a distance of a hundred miles from the source of sound; while a drop of water falling on the base has a loud crashing sound. To obtain the best results with a particular instrument, the position of the carbon must be carefully adjusted by trial; and indeed the form of the instrument itself must be variously modified for the special object in view; in some cases great sensitiveness is required, in others great range. In order to eliminate as far as possible the effect of accidental vibrations due to the supports, the base should rest on pieces of vulcanised tubing, or on wadding.

When a small disturbance is made either in the air close to the microphone or on its support, the contact between D and the upper and lower socket is varied, and consequently the electric resistance of the contacts, and

possibly of the carbon D itself, in consequence of the slight increase or diminution of pressure upon it, alters, and the resulting variations in current cause sounds to be heard in the telephone.

The form of the original microphone has been variously modified. It is desirable to increase the number of contacts, so as to avoid scratching noises. The Ader microphone consists of ten carbon rods laid in two sets of five each on three cross-pieces, also of carbon, fixed to the same piece of wood. Good results are also obtained by using small fragments or filaments of carbon.

In modern telephone circuits the microphone in some form is generally employed as a sending instrument, the ordinary Bell telephone as a receiver. The usual method is to arrange a small induction coil, about the size of an ordinary cotton reel, with a primary of thick, and a longer secondary of thin, wire. The primary circuit includes battery and microphone transmitter. One end of the secondary is put to earth and the other to a Bell telephone receiver and thence to the telephone line. A person holding the telephone to his ear will receive any message coming from the distant station, the currents passing through the telephone and to earth. The message to be transmitted is spoken to a thin wooden sounding-board on the back of which a number of microphone contacts, like that of fig. 981, are arranged in parallel. The changes of resistance of the carbons give rise to variations of current in the primary circuit of the induction coil, and every such change causes a corresponding induced current in the secondary which travels to the other station. Another form of transmitter consists of granulated carbon partially filling the space between two parallel carbon discs connected in the primary circuit. The impact of sound waves on one of the carbon discs (placed immediately behind the mouth-piece of a transmitter) alters the contact of the granules, and so produces the necessary changes of current.

973. **The telegraphone.**—This is an apparatus invented by Poulsen for recording magnetically on a steel wire a speech spoken into a telephone, the speech being recoverable from the wire after any interval of time. It is a magnetic phonograph (293). The principle of the apparatus is as follows :—A tiny horseshoe electromagnet, connected in circuit with a telephone, is made to travel with uniform velocity over a stretched steel wire, the wire lying between the two poles of the electromagnet. During the motion any words spoken into the telephone are recorded as a series of magnetic fields on the wire. To reproduce the record the magnet is connected to a telephone receiver and is again made to travel along the wire ; as the now magnetised wire passes between its poles it sets up currents which reproduce the recorded speech in the receiver. The record can be left on the wire and used over and over again. If it is desired to wipe out the record a steady current is passed through the magnet coils as it travels from end to end of the recording wire ; this destroys the existing record and leaves the wire ready to receive a fresh one. In the actual instrument the steel wire is wound spirally on a drum which can be rotated by a motor.

974. **Hughes's induction balance.**—The principle of this apparatus may be thus stated :—Suppose we have two exactly equal primary induction coils, A and A', and near them two secondary coils, B and B', also exactly equal, and connected up with a galvanometer, so that the coils act upon it in

opposite directions. If now the current of a battery is sent through the primary coils, joined in series, the inductive effects on each of the secondary coils will be the same, and, as their action on the galvanometer is opposed, no deflection of the needle will be produced. If, however, a piece of iron is introduced into the core of one of the secondary coils, the equality in the induction effects will be destroyed, and the needle of the galvanometer at once deflected.

This principle was first applied by Babbage, Herschel, and in a special apparatus by Dove; but the microphone and the telephone have led the inventor of the former to the invention of an apparatus which has opened out new possibilities, and has placed in the hands of the physicist an elegant and powerful engine of research, which in certain departments of investigation promises to be of great service.

The form of instrument as devised by Professor Hughes is represented in fig. 982, where the essential parts are drawn to scale, though the relative distances of the parts are not so; a and a' are the two primary coils, each of

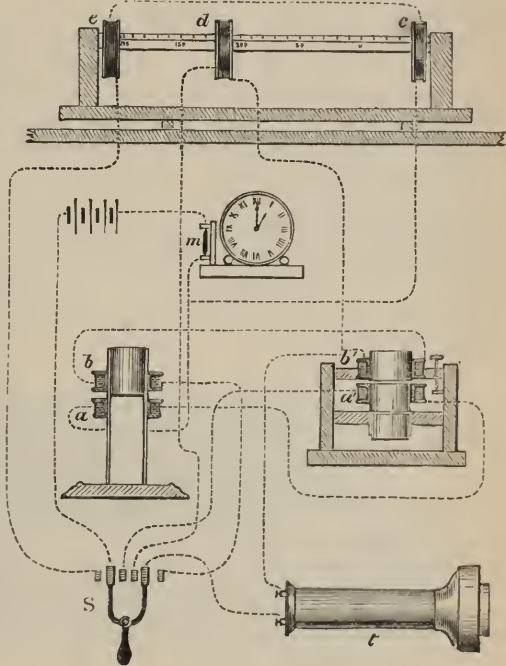

Fig. 982

which consists of 100 metres of fine copper wire wound on a flat boxwood spool; b and b' are two secondary coils, all four coils being, in intention at least, exactly alike. The two primary coils are joined in series with a battery of 3 or 4 volts, in which circuit a microphone, m , is also inserted; the ticking of a small clock on the table acts as make and break.

The secondary coils are joined up with a telephone in such a manner that their action upon it is opposed.

Now, whatever care may be taken in winding the wire on the coils, it is not possible to get at the outset an exact balance. Hence, while the distance between a and b is fixed, that between a' and b' is not so, but can be slightly modified by means of a micrometer screw, and thus, connection with the battery circuit having been made, a balance is obtained by slightly varying the adjustment, and the accomplishment of this is known by there being silence in the telephone. But if now any metal whatever is introduced into one of the secondary coils, a sound is at once heard.

This arrangement is so far a simple differential one, and furnishes as yet no means of measuring the forces brought into play, and for this purpose Hughes uses what is called a *sonometer* or *audiometer*. This consists of three similar coils, c , d , and e , placed vertically on a horizontal graduated rule along which d can be moved. By means of a *switch*, S , the primary coils c and e can be put in communication with the battery and microphone circuit quite independently of the balance, and it is so arranged that the ends of the coils c and e facing each other are of the same polarity; the third coil, d , the secondary one, is connected with the telephone circuit.

If these primary coils c and e were quite equal, then, when connected up with the battery circuit, no sound would be heard in the telephone, when the secondary d is exactly midway between them. But as the coil is moved from this position either towards c or e a sound is heard, due to the preponderance of one or the other. In practice the coils are so arranged that a balance is obtained when the secondary circuit is near one of the coils, c , for instance; this represents a zero of sound, and as the coil d is moved nearer to e a sound of gradually increasing intensity is heard; distances measured off along this line represent values of sound on an arbitrary scale.

Suppose now that a balance has been obtained in the induction balance, and that the coil d in the sonometer is at zero; no sound is then heard in the telephone when the current is switched either in one or the other circuit. But if the balance is disturbed by placing a piece of metal in the core of b , a definite continuous sound is heard. The current is then switched into the sonometer, and the secondary coil d is moved until the ear perceives the same sound in both circuits. The distance along which the coil d has been moved is thus an arbitrary measure of the effect produced.

Although by the switch the transition from one circuit to the other can be effected with great rapidity, and the ear can appreciate minute differences, this has not the value of a null method. Hughes still further improved the balance by the following device, in which the sonometer was dispensed with:—A graduated strip of zinc about 200 mm. in length by 25 mm. wide, and tapering from a thickness of 4 mm. at one end to a fine edge at the other, is made use of. The metal to be tested is placed in a plane between a and b on the left of the plate, and the strip is moved along the top of b' until a balance is obtained.

The instrument is of surprising delicacy; a milligramme of copper or a fine iron wire introduced into one of the coils which has been balanced can be loudly heard, and appreciated by direct measurement. If two shillings fresh from the Mint are balanced, rubbing one of them or breathing on it at once disturbs the balance. A false coin balanced against a genuine one is at once detected. The instrument furnishes a means of testing the delicacy of hearing; such a piece of wire as the above, or a fine spiral of copper, furnishes a kind of test object for this purpose.

CHAPTER XI

PASSAGE OF ELECTRICITY THROUGH GASES

975. **Inductorium. Ruhmkorff's coil.**—Induced currents of high potential, and capable of producing many striking effects, are furnished by apparatus known as *inductoriums*, or *induction coils*. These present considerable variety in their construction, but all consist essentially of a hollow cylinder in which is a bar of soft iron, or bundle of iron wires, with two helices coiled round it, one connected with the poles of a battery, the circuit of which is alternately opened and closed by a self-acting arrangement, and the other serving for the development of the induced current. By means of these apparatus, and with an applied E.M.F. of 8 or 10 volts, physical, chemical,

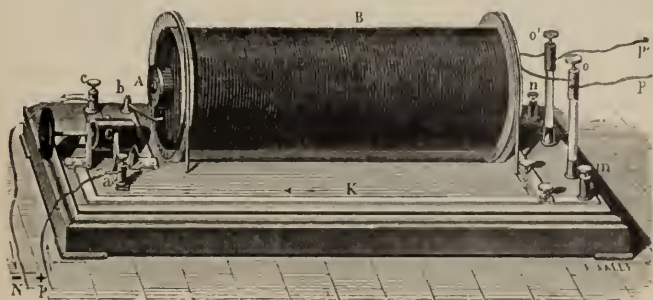

Fig. 983

and physiological effects are produced equal to and even transcending those obtainable with electric machines and the most powerful Leyden batteries.

Fig. 983 is a representation of a powerful induction coil constructed by Ruhmkorff, the coil of which is about 35 cm. in length. The *primary* wire is of copper, and is about 2 mm. in diameter, and 40 or 50 metres in length. It is coiled directly on a cylinder of cardboard, which forms the nucleus of the apparatus, and is enclosed in an insulating cylinder of ebonite. On this is coiled the *secondary* wire, which is also of copper, and is about $\frac{1}{4}$ mm. in diameter. A matter of great importance is the insulation of the secondary wire. The wires are not merely insulated by being in the first case covered with silk, but each individual layer is separated from the rest by melted shellac. In the more recent induction coils, the secondary wire is wound in sections separated from each other by annular sheets of ebonite. The length of the secondary wire varies greatly; in the largest size hitherto made, that

of the late Mr. Spottiswoode, it is as much as 280 miles, while the primary was 1164 yards. With these great lengths the wire is thinner, about $\frac{1}{8}$ mm. The thinner and longer the wire the higher the potential of the induced electricity.

In an average modern induction coil giving a 10-inch spark, such as is used in wireless telegraphy, the primary wire consists of 100 yards of No. 12 gauge copper wire (diameter = 2.64 mm.), its resistance being about a third of an ohm. The secondary is about 10 miles long and has a resistance between 6000 and 7000 ohms. The coefficient of self-induction of the secondary is about 450 henrys (967), that of the primary being about .02 henry.

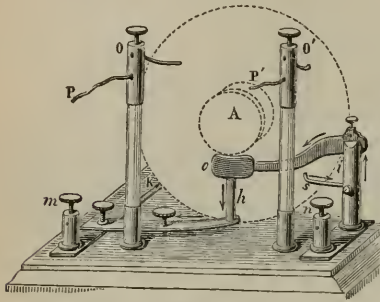

Fig. 984

The following is the working of the apparatus:—The current arriving by the wire P at a binding screw, *a*, passes thence to the commutator C, to be afterwards described (fig. 986), from which by the binding screw *b* it enters the primary wire, and having traversed this, it emerges by the wire *s* (fig. 984). Following the direction of the arrows, it will be seen that the current ascends in the pillar *z*, reaches an oscillating piece of iron, *o*, called the *hammer*, descends by the *anvil* *h*, and passes into a copper plate, K, which takes it to the commutator C.

It goes from there to the binding screw *c*, and finally to the negative pole of the battery by the wire N.

The current in the primary wire only acts inductively on the secondary wire (957), when it is interrupted. The necessary interruption is effected by means of the oscillating hammer *o* (fig. 984). In the centre of the bobbin is a bundle of soft-iron wires, forming together a cylinder a little longer than the bobbin, and thus projecting at the end as seen at A. When the current passes in the primary, the hammer, *o*, is attracted; but immediately, there

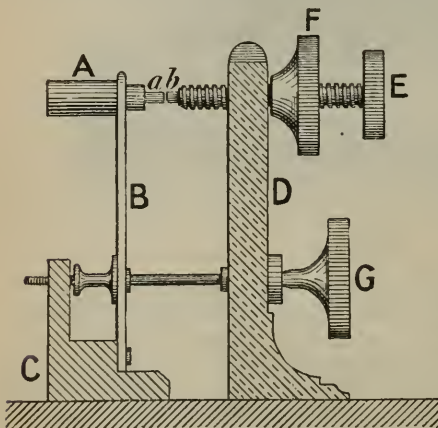

Fig. 985

being no contact between *o* and *h*, the circuit is broken, the magnetisation ceases, and the hammer falls; the current again passing, the same series of phenomena recommences, so that the hammer oscillates with great rapidity.

A more effective current interrupter or *make and break* is shown in fig. 985. A is the soft-iron hammer attached to the top of a stiff brass spring B, the tension of which can be regulated by a screw G. It is tipped

with platinum at *a*. D is a brass upright with a brass screw passing through it, also tipped with platinum at *b*. The screw can be adjusted in position by the head E and clamped by the nut F. The primary current passes from the commutator to D, thence across the contact *ab*, down the spring B, and into the primary wire. As soon as the circuit is complete, A is attracted to the left by the magnetised core (not shown in the figure) and contact at *ab* is broken. The rapidity of oscillation of the vibrator and the sharpness of the break can be regulated to some extent by the screw-head G.

976. **Condenser.**—As the current passes thus intermittently in the primary wire of the coil, induced electromotive forces, alternately direct and inverse, are produced in the secondary wire. As the secondary wire is carefully insulated and of great length, and as the interrupter breaks the primary circuit with considerable sharpness, the induced electromotive force is capable of producing very powerful effects. Fizeau increased the electromotive force still more by connecting the terminals of a condenser to the two sides of the make and break.

This condenser consists of sheets of tinfoil placed over each other and insulated by larger sheets of stout paper soaked in paraffin or resin (931). The whole being placed in a box at the base of the apparatus, one of the coatings is connected with one side and the other coating with the other side of the make and break in the primary circuit—that is, one coating is connected to *a*, the other to *b* (fig. 984), or one to C and the other to D (fig. 985).

The capacity of the condenser should bear a relation to the self-induction of the primary circuit and the rapidity of the contact-breaker. To understand the effect of the condenser, it must be observed that at each break of the primary circuit a direct extra current is produced in it, the E.M.F. of which is sufficient to produce a large spark between the platinum terminals *a* and *b* (fig. 985). When the condenser is connected, the electric charges, instead of producing so strong a spark, pass into the condenser, but rebounding, traverse the circuit and give rise to a current through the primary contrary to that of the battery, which instantly demagnetises the soft-iron core. Hence the E.M.F. induced in the secondary, which depends upon the rapidity with which the lines of force disappear, is much greater than it would be without the condenser, and the injurious effect of the spark between *a* and *b* is to a large extent prevented.

The *commutator* serves to break contact or send the primary current in either direction. It is seen on the right of fig. 983, and fig. 986 shows a section. The ebonite cylinder, A, has brass plates, C C', on opposite sides. Against these press two elastic brass springs, joined to two binding screws, *a* and *c*, with which are also connected the poles of the battery. The current arriving at *a* rises in C; thence by a screw, *y*, it reaches the binding screw *b* and the primary winding; then returning by the plate K, which is connected with the hammer, the current goes to C' by the screw *x*; descends to *c*, and rejoins the battery by the wire N. If, by means of the milled head, the key is turned 180 degrees, it is easy to

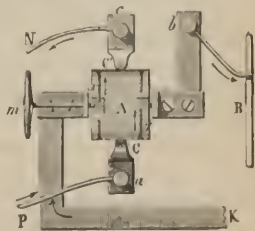

Fig. 986

see that exactly the opposite takes place : the current reaches the hammer by the plate K and emerges at *b*. If, lastly, it is only turned through 90 degrees, the elastic springs rest on the ebonite A instead of on the plate CC', and the circuit is broken.

The two wires from the apparatus at *o* and *o'* (fig. 983) are the two ends of the secondary coil. They are connected with the thicker wires P P', so that the current can be sent in any desired direction. With large coils the hammer cannot be used, for the surfaces become so much heated as to melt. But Foucault invented a mercury contact-breaker which is free from this inconvenience, and which is an important improvement. Very powerful discharges were obtained by Spottiswoode from his coil by disconnecting the contact-breaker and sending into it the alternate currents of a powerful magneto machine.

Another form of current breaker is *Wehnell's electrolytic interrupter*. It consists of an anode of stout platinum wire, projecting about a quarter of an inch from a glass tube into which it is fused, and a lead plate for kathode, the two being immersed in sulphuric acid (1 of acid to 5 of water). When a current passes from a source of 20 to 100 volts the platinum glows intermittently, and the circuit is made and broken with great rapidity. A long thick spark shaped thus \wedge is produced between the terminals of the secondary, whose frequency depends upon the size of the platinum anode, the volts applied, and the self-induction in the primary. The explanation of the action is to be found partly at least in the spheroidal state (390) intermittently assumed by the liquid in the neighbourhood of the hot platinum.

977. **Effects produced by Ruhmkorff's coil.**—The high potential of the electricity of induction coils has long been known, and many luminous and heating effects have been obtained by their means. But it is only since the improvements which Ruhmkorff introduced into his coil that it has been possible to obtain the large electromotive forces now common.

Induced electromotive forces are produced in the secondary coil at each opening and closing of the primary. But these E.M.F.s are of very unequal intensity. When the primary circuit is closed, the E.M.F. of the battery is opposed by that due to self-induction, and the current (and with it the magnetic field) rises only gradually to its full value. But on breaking the primary circuit, owing to the action of the condenser, these same lines of force are removed with great rapidity. Hence the E.M.F. on 'break' is high and of short duration, while that on 'make' is relatively feeble and of much longer duration. If the terminals of the secondary are brought within a millimetre of each other, and the 'make and break' worked by hand, it is found that a bright spark passes on break, but none at all on make. But if a galvanometer is placed in the circuit of the secondary, the opposite throws of the needle are the same on making and on breaking the primary, showing that the quantity of electricity passing through the instrument is the same in the two cases; hence, when the interrupter is working automatically, the needle, being equally urged in opposite directions in rapid succession, suffers no permanent deflection.

A striking distance of 1 mm. (805) corresponds to an electromotive force of 5490 volts; and the striking distance of 1 inch, which is furnished by even a small machine, represents a potential of over 70,000 volts.

The *physiological* effects of Ruhmkorff's coil are very powerful ; in fact, shocks are so violent that many experimenters have been suddenly prostrated by them. A rabbit may be killed with two Bunsen cells, and a somewhat larger number would kill a man.

The *heating* effects are also easily observed : an air thermometer is heated by the alternating currents ; if a very fine iron wire is interposed between the two ends P and P' of the secondary (fig. 983), this wire is immediately melted, and burns with a bright light. A curious phenomenon may here be observed, namely, that when each of the wires P and P' terminates in a very fine iron wire, and these two are brought near each other, the wire corresponding to the negative pole alone melts, showing that its temperature is higher.

The *chemical* effects are very varied ; thus, according to the shape and distance of the platinum electrodes immersed in water, and to the degree of acidulation of the water, either luminous effects may be produced in water without decomposition, or the water may be decomposed and the mixed gases disengaged at the two electrodes, or the decomposition may take place, and the mixed gases separate either at a single pole or at both poles.

Gases may also be decomposed or combined by the continued action of the spark from the coil. If the terminals of a small Ruhmkorff coil are connected to two platinum wires passing through an hermetically sealed tube containing air, their ends being separated by a small gap, as shown in fig. 987, moist nitrogen and oxygen combine to form nitrous acid.

The *luminous* effects of Ruhmkorff's coil are also very remarkable, and vary according as they take place in air, in vapour, or in very rarefied gases. In air the coil produces a very bright loud spark, which, with the large coil made for the late W. Spottiswoode, has a length of 42 inches. In vacuo the effects are also remarkable. The experiment is made by connecting the two wires of the coil P and P' with the two rods of the electric egg (805) used for producing in vacuo the luminous effects of the electric machine. Exhaustion having been produced up to 1 or 2 mm. by a Fleuss Pump (205), a beautiful luminous trail is produced from one knob to the other, which is virtually constant, and has the same intensity as that obtained with a powerful electric machine when the plate is rapidly turned. This experiment is shown in figs. 991 and 992. Fig. 990 represents a remarkable deviation which light undergoes when the hand is presented to the egg.

The positive pole shows the greater brilliancy ; its light is of a fiery red, while that of the negative pole is of a feeble violet colour ; moreover, the latter extends along all the length of the negative rod, which is not the case with the positive pole.

The coil also produces mechanical effects so powerful that, with the largest apparatus, glass plates two inches thick have been perforated. This result, however, is not obtained by a single discharge, but by several successive discharges.

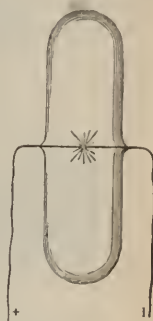

Fig. 987

The experiment is arranged as shown in fig. 988. The two ends of the secondary wire are connected with the binding screws *a* and *b*; by means of a copper wire, the terminal *a* is connected with the lower part of an apparatus for piercing glass like that already described (fig. 793); the other terminal is attached to the other conductor by a wire *d*. The latter is insulated in a large

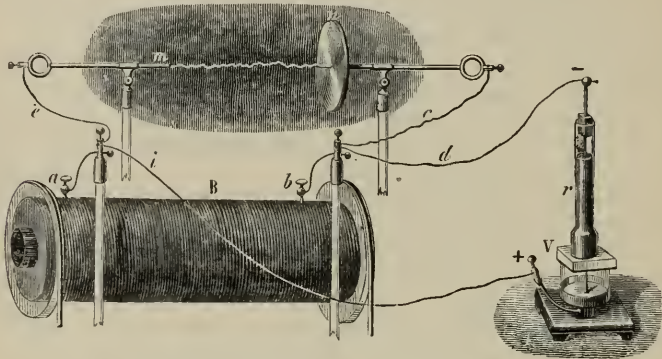

Fig. 988

glass tube *r*, filled with shellac, which is run in while in a state of fusion. Between the two conductors is the glass to be perforated, *V*. When this presents too great a resistance, there is danger lest the spark pass in the coil itself, perforating the insulating layers which separate the wires, and then the coil is destroyed. To avoid this, two wires, *e* and *c*, connect the poles of

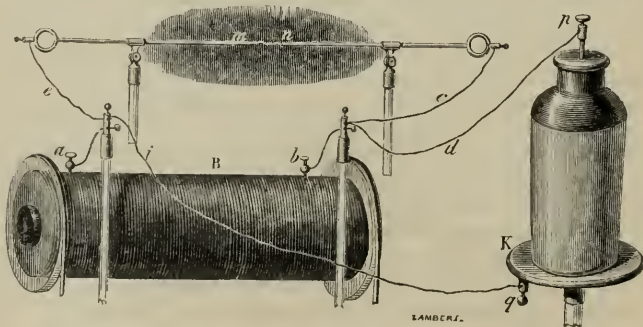

Fig. 989

the coil with two metallic rods whose distance from each other can be regulated. If then the spark cannot penetrate through the glass, it strikes across, and the coil is not injured.

The coil can also be used to charge Leyden jars. With a large coil giving sparks of 6 to 8 inches, and with 6 large Bunsen cells, Ruhmkorff charged batteries of 6 jars each, having about 3 square yards of coated surface.

The experiment with a single Leyden jar (fig. 989) is made as follows:—The coatings of the latter are in connection with the poles of the coil by the wires *d* and *i*, and these same poles are also connected, by means of the wires *e* and *c*, with the two horizontal rods of a universal discharger (fig. 772). The jar is then being constantly charged by the wires *i* and *d*, sometimes in one direction and sometimes in another, and as constantly discharged by the wires *e* and *c*; the discharges from *m* to *n* taking place as sparks two or three inches in length, very luminous, and producing a deafening sound. The discharges of the jar take place in one direction only, since the D.P. between *m* and *n* at 'make' of primary is insufficient to produce a spark.

978. **Stratification of the electric light.**—Quiet observed, in studying the electric light which Ruhmkorff's coil gives in a vacuum, that if some

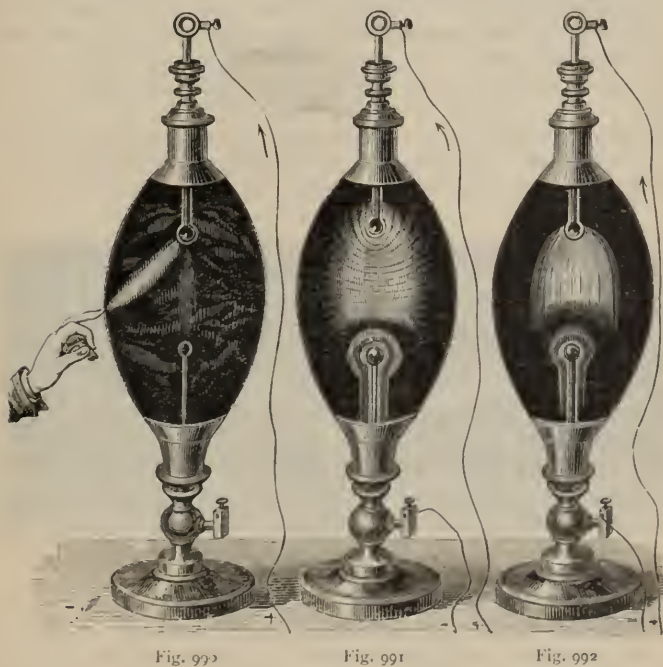

Fig. 990

Fig. 991

Fig. 992

of the vapour of turpentine, wood spirit, alcohol, or carbon bisulphide, &c., is introduced into the vessel before exhaustion, the aspect of the light is totally modified. It appears then like a series of alternately bright and dark zones, forming a pile of electric light between the two electrodes (fig. 991).

In this experiment it follows, from the discontinuity of the current of induction, that the light is not continuous, but consists of a series of discharges which are nearer each other in proportion as the hammer A (fig. 985) oscillates more rapidly.

The light of the positive pole is most frequently red, and that of the

negative pole violet. The tint varies, however, with the vapour or gas in the globe.

979. **Geissler's tubes.**—The brilliancy and beauty of the stratification of the electric light are most remarkable when the discharge of the Ruhmkorff coil takes place in glass tubes containing a highly rarefied vapour or gas. These phenomena, which were originally investigated by Gassiot, are produced by means of sealed glass tubes first constructed by Geissler, of Bonn, and generally known as *Geissler's tubes* (589). The tubes are filled with different gases or vapours, and are then exhausted, so that the pressure does not exceed half a millimetre. At the ends of the tubes two platinum wires are fused into the glass.

When the two platinum wires are connected with the ends of a Ruhmkorff coil, magnificent lustrous striæ, separated by dark bands, are produced throughout the tube. These striæ vary in shape, colour, and lustre with the degree of the vacuum, the nature of the gas or vapour, and the dimensions of the tube. The phenomenon has occasionally a still more brilliant aspect from the fluorescence which the electric discharge excites in the glass.

Fig. 993 shows the striæ in carbonic acid under a quarter of a millimetre pressure; the colour is greenish, and the striæ have not the same form as in hydrogen. In nitrogen the light is orange yellow.

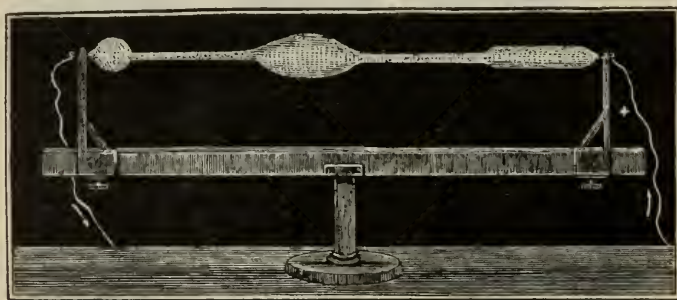

Fig. 993

Plücker found that the light in a Geissler's tube did not depend on the substance of the electrodes, but on the nature of the gas or vapour in the tube. He found that the lights furnished by hydrogen, nitrogen, carbonic oxide, &c., give different spectra when they are decomposed by a prism.

980. **De la Rue and Müller's experiments.**—These physicists made a very extensive and elaborate series of experiments on the stratification of the electric light by means of the currents produced by their battery (826). They employed for some of these experiments as many as 14,400 cells, which is a battery of the highest electromotive force ever put together. It is impossible to attempt to describe here more than a few of the results obtained.

All the striæ start from the positive pole. For a definite pressure an aureole is formed at the positive pole; with a diminished pressure this detaches itself, is succeeded by others, and so on.

One of the most curious results is the definite and stationary character of the striæ for given conditions: they are remarkably permanent, and seem almost as if they could be manipulated; a single stria may be seen falling down a tube like a feather in a vacuum, or like a drop of water.

The length of the spark between two terminals varies with the square of the number of cells; thus while 1000 cells give a spark of 0.0051 inch under ordinary atmospheric pressure, 11,000 cells give a spark of 0.62 inch.

With an increase of exhaustion the potential necessary to cause a discharge to pass diminishes to a certain pressure which represents an exhaustion of least resistance; from this it again increases, and the strata thicken and diminish in number until a point is reached at which no discharge takes place, however high be the potential.

A change in the current often produces an entire change in the colour of the stratification; thus in hydrogen the change is from blue to pink, due to *rise* or *fall* of current. If the discharge is irregular and the strata indistinct, an alteration in the strength of the current makes the strata distinct and steady. Even when the strata are apparently quite steady and permanent, a pulsation may be detected in the current by means of the telephone.

The colour of the discharge in one and the same gas greatly depends on the degree of rarefaction. The least resistance to the discharge in hydrogen, and when its brilliancy is greatest, is at a pressure of 0.642 mm. or 8.45 **M** (**M** is a very convenient symbol for the millionth of an atmosphere). When the rarefaction has attained 0.002 mm. or 3 **M**, the discharge only just passes even with a potential of 11,330 volts; while with an exhaustion of 0.000055 mm. (= 0.08**M**), the nearest approach to a perfect vacuum ever attained, not only is there no discharge due to the large battery employed, but the 1-inch spark of an induction coil does not pass.

At a given pressure, air offers a greater resistance than hydrogen; a spark which passes in hydrogen across a distance of 5.6 mm. will strike across a distance of only 3 mm. in air.

In air at a pressure of 62 mm., which corresponds to an atmospheric height of 12.4 miles, the electric discharge has the carmine tint so often seen in the display of the aurora borealis (1044); at a pressure of 1.5 mm., corresponding to a height of 30.96 miles, it is salmon-coloured; and at a pressure of 0.8 mm., representing a height of 33.96 miles, it is of a pale white. Under a pressure of 0.379 mm. the discharge has the greatest brilliancy. This represents a height of 37.67 miles, and would be visible at a distance of 585 miles: it is probably the upper limit of the height, though on the other hand it is possible that the discharge may sometimes take place at a height of a few thousand feet.

The electric discharge does not pass through a vacuum, as is shown by the following experiment:—A small tube containing caustic potash is fused to a Geissler's tube connected with a Sprengel pump. By continual exhaustion while the caustic potash is being heated, as complete a vacuum as possible is made and the tube sealed. The last minute trace of aqueous vapour is absorbed by the caustic potash as it cools. In this complete vacuum the discharge, however strong, no longer passes; the vacuum acts as a complete non-conductor.

If, however, the caustic potash is gently heated, a trace of aqueous vapour

is given off, and a green fluorescent light flashes along the tube; as the heating is continued and the vapour becomes denser we get the stratification, until ultimately the electricity passes along the tube in the form of a narrow purple line. If the tube is allowed again to cool, the phenomena reproduce themselves in the reverse order.

981. **Kathode rays.**—The phenomena of the electric discharge in highly rarefied gases have been examined by Hittorf and by Sir W. Crookes; the most complete and remarkable experiments are those due to the latter.

When the wires from a Ruhmkorff coil or from an influence machine are connected up with a vacuum tube, a discharge passes; if the air has been rarefied to about $\frac{1}{300}$ of an atmosphere, the negative pole is surrounded by a faint bluish light, the glow light, while from the positive electrode, the anode, a peach-blossom coloured stream of light passes, filling the greater part of the tube, being separated from the glow light of the kathode by a dark space. The stream of light appears continuous, but when viewed in a rotating mirror it is seen to be stratified, that is, made up of alternate dark and bright spaces. This stream of light from the anode has the character of a movable conductor, and is attracted or repelled by a magnet.

As the rarefaction proceeds the glow light of the kathode and the dark space extend continually farther towards the anode, the positive light receding in the same measure; this goes on with increasing rarefaction until the

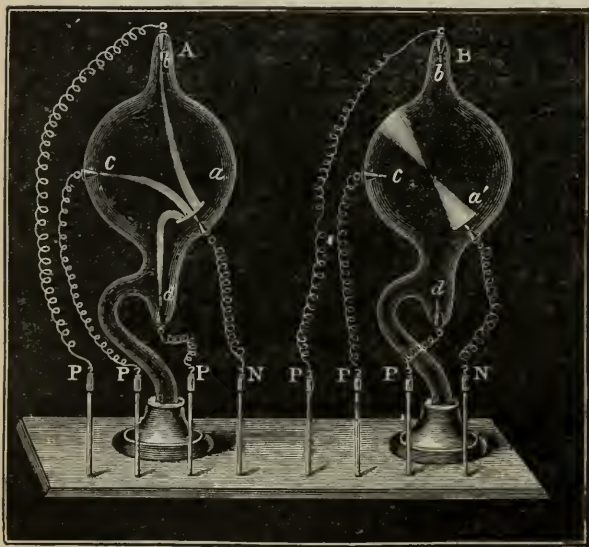

Fig. 994

positive light wholly disappears, and the rays from the kathode entirely fill the tube. Such rays are known as *kathode rays* and have many striking peculiarities. The light is faint, but when it strikes against the glass at the opposite end of the tube it excites the brightest fluorescence, with a colour which is affected by the nature of the glass. The rays proceed

from the kathode in straight lines, and do not follow any bends in the tubes. This rectilinear propagation is well illustrated by the following experiment of Crookes. In fig. 994, A, the negative pole of the induction coil is connected with the electrode *a*, which is made of aluminium, and forms a slightly con-

cave mirror. If the exhaustion is not more than 2 mm. pressure, and the positive pole is connected successively with the electrodes *b*, *c*, *d*, the discharge takes place in curved lines as shown in the figure. But when the rarefaction is exceedingly great, about a millionth of an atmosphere, the appearance is that presented in fig. 994, B. With whatever electrode the positive pole is connected, the rays proceed from the anode in straight lines, cross in the centre of curvature of the mirror, and, striking against the opposite side, excite there the most brilliant fluorescence.

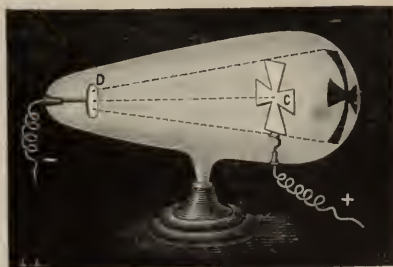

Fig. 995

The phenomena occur as if particles were shot from the negative electrode at right angles to the surface. Thus in fig. 995 the kathode *D* is a small slightly convex mirror of aluminium, while *c* is a cross of aluminium or mica which is so fastened by a small joint that it can be raised or lowered. When the discharge passes the kathode rays proceed in straight lines and impinging on the glass make the whole of it fluorescent except that portion corresponding to the cross, which thus throws a shadow. If the cross *c* is lowered, the part which was previously in shadow is now more brightly luminous than the rest, so that a bright cross stands out on a less bright ground. This is due to the fact that the brightness of the fluorescence is a maximum when the kathode rays first impinge and wanes with continued bombardment. Hence when the cross is thrown down, that part of the glass which has been protected looks brighter than the rest.

The kathode rays can also produce mechanical effects favouring the view of the material character of these radiations. A Geissler's tube (fig. 996) is constructed with a pair of glass rails in it, on which rolls the axis

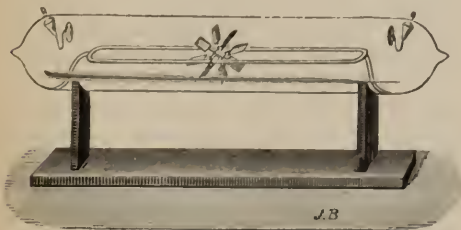

Fig. 996



Fig. 997

of a light wheel, on the spokes of which are mica vanes. If the discharge is directed against the top of the vanes, the wheel moves along towards the anode.

The experiment represented in fig. 997 shows the very great heat which cathode rays can produce; *a* is the negative electrode in the form of a concave mirror, *b* a strip of platinum foil. With a sufficiently powerful induction coil the platinum can be made white-hot or even melted.

Some of the most beautiful of these experiments are those made by directing the discharge on various precious stones. In these circumstances diamond emits a splendid green fluorescence, ruby a brilliant red, emerald a carmine, and so forth.

The phenomena here described are regarded by Crookes as due to an *ultra-gaseous* state, which he calls *radiant matter*. In gas under the ordinary pressure the average free path of a molecule of air is 0.0001 mm.; as the gas is more rarefied the length of the path increases, so that with the high degrees of exhaustion which Crookes employs in his later experiments—as much as the one twenty-millionth of an atmosphere—the length of the mean path is so much increased that its dimensions are comparable with those of the vessel, and along with this increase the number of intermolecular shocks diminishes in a corresponding ratio. It is to this condition, in which the molecules move forward with unimpeded motion, and, striking against the sides, give rise to the fluorescence, that Crookes attributes the effects produced.

It was believed for a long time that cathode rays were unable to penetrate even the thinnest slice of a solid. Lenard, however, showed that these rays could pass through a thin film of aluminium and that their properties were in no respect modified by the passage. He made a small aperture in the end of a tube opposite the cathode, and closed it by thin aluminium foil. When this tube was exhausted to about the one-millionth of an atmosphere, the cathode rays passed through the window of aluminium into the air, causing a faint bluish light, which had no fixed boundary but did not extend to more than 5 cm. These rays, called *Lenard rays*, are more easily studied if the window, instead of opening upon the air, opens into another tube from which the air can be exhausted. They appear to have all the properties of cathode rays. Lenard investigated their absorption by various media, and found a simple relation connecting the absorption with the density. He regarded these rays as a phenomenon of the ether, and not as due to the existence of ordinary matter in the tube.

982. **Velocity, mass, and charge of an ion.**—Perrin showed that cathode rays carried negative electricity with them, and J. J. Thomson found that when the rays are deflected by a magnet, the negative electrification follows the path of the deflected rays. J. J. Thomson and others have investigated the velocity with which the negatively charged ions travel, and also the ratio of the charge which each ion carries to the mass of the ion. One of the methods employed depends upon the fact that the cathode stream is deflected both by a magnetic and by an electric field. When both fields are applied at the same time at right angles to each other, it is possible, by regulating the strength of the fields, to make the deflections exactly neutralise each other, and when this is the case the ratio of the two fields gives the velocity required. In this way, Thomson found the velocity of the ions to be 2.8×10^9 cm./sec., or about 1/10 the velocity of light. This same value was also obtained by Thomson by a different method, and has been confirmed

by Lenard and others ; it is the same whether the discharge takes place in air or in hydrogen or in carbonic acid, in each case a high vacuum being necessary.

Again, by measuring the curvature of the path of the deflected rays produced by a magnetic field, J. J. Thomson determined the ratio e/m , m being the mass of an ion and e its charge. By this and by other methods employed by various investigators (Lenard, Wiechart, &c.) e/m has been found to be equal to 10^7 .

The value of e/m in the case of liquid electrolysis, for example when e is the charge of a hydrogen ion and m is its mass, is 10^4 . But in all the cases in which the charges on the ions in gaseous vacua (air, hydrogen, carbonic acid) have been compared with the charge on the hydrogen ion in the electrolysis of solutions they have been proved equal to it. Hence it follows that m , the mass of the carrier of a negative charge in a highly rarefied vacuum tube, is only $1/1000$ of that of an atom of hydrogen, and thus we have to admit the existence of bodies whose mass is only $1/1000$ part of that which has hitherto been regarded as the smallest indivisible unit. They are called *electrons* or *corpuscles*. The charge (e) carried by a corpuscle is 3.4×10^{-10} (940).

983. **Röntgen rays.**—Röntgen surrounded a tube, in which kathode rays were formed, by an envelope of black cardboard, and observed that a screen coated with barium platinocyanide, brought near the envelope, became highly fluorescent, whether the coated or uncoated side of the screen was presented. The effect was produced even at a distance of two metres.

This effect is due to what have been called *X* or *Röntgen* rays, and must be considered as originating in that portion of the tube which fluoresces in consequence of its being struck by the kathode rays ; and from this surface the *X* rays spread in all directions. They are not identical with the kathode rays, though produced by them.

Unlike the kathode rays, they are not deflected by a magnet ; they pass readily through paper, wood, leather, and ebonite. Different metals transmit them in very various proportions ; for example, an aluminium plate 3.5 mm. thick ; zinc, 0.1 mm. ; lead, 0.05 mm. ; and platinum 0.018 mm. were all about equally transparent. When passed through prisms of aluminium or ebonite they are not refracted, nor are they concentrated by a lens ; they do not seem to be reflected regularly.

They act on ordinary sensitive dry plates even when in a closed slide, and even also when this is wrapped in black paper. To protect such a plate from the action of the rays, the slide must be wrapped in lead foil.

If the hand is held over a sensitive plate contained in a slide, and exposed to the rays, the plate on development shows an image of the skeleton of the hand, for the rays pass with more difficulty through the bones than through the soft parts of the hand. A number of important applications to surgery have already been made.

The form of tube which has been found best for producing these rays is shown in fig. 998. A and K are the anode and kathode respectively, K being a disc of aluminium rendered concave, with its centre of curvature at the centre of the platinum plate A, which is inclined at 45° to the axis of the tube. When the tube is sufficiently exhausted kathode rays proceeding

from K are concentrated on a small area of A, and from this Röntgen rays proceed in straight lines, chiefly in the direction of the arrow. Such a tube is called a *focus-tube*.

One of the most remarkable properties of Röntgen rays is their power of ionising the air, that is, rendering it a conductor of electricity. If the focus-

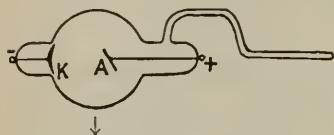

Fig. 998

tube and induction coil are placed inside a metal box, in which an opening is made in front of the focus-tube, and the opening closed by a thin aluminium window, the Röntgen rays can only escape through the window. When a charged electroscope is placed in front of the window and the coil is excited, the leaves at once collapse, even when the electroscope is some distance away, the charge escaping through the conducting air. The air appears to retain its conductivity for some time, for though the electroscope, when placed on one side out of the line of discharge of the rays, is unaffected when the coil is turned on, the leaves at once collapse when the ionised air is blown by a bellows on the cap. Positive and negative electricity are discharged with equal facility. When knobs connected to the two coatings of a charged Leyden jar are at such a distance apart that no discharge occurs, sparks will at once pass between the knobs when the jar is placed in the path of the rays. Non-conductors, as well as conductors, are acted on; a rod of excited sealing-wax or glass at once loses its charge when held near the focus-tube.

984. **Radio-activity.**—In 1896, soon after the publication of the discovery of Röntgen rays, Becquerel found that a photographic plate covered up in black paper or thin aluminium foil was acted on by the salts of uranium and by the metal itself. Rays producing these effects were known as *Becquerel rays*. Further, the radiation from uranium, like the Röntgen rays, rendered the air through which it passed a conductor of electricity. Since that time other substances have been discovered which spontaneously emit rays similar to those of uranium. Such bodies are called *radio-active*. M. and Madame Curie discovered the element *radium*, which transcends all other bodies in the energy of its radiation, and Rutherford and others have studied the radio-activity of *thorium*, which was shown by Schmidt in 1898 to give out rays very similar to those emitted by uranium. A radio-active body may be defined as one spontaneously emitting radiations which to a greater or less extent (1) act upon a photographic plate in a dark room, (2) excite phosphorescence, and (3) ionise the gas through which they pass, *i.e.* render it a conductor of electricity.

Uranium occurs chiefly as an oxide in the mineral *pitch-blende*, and the fact that some specimens of pitch-blende appeared to be more radio-active than uranium itself led M. and Madame Curie to a chemical examination of pitch-blende involving enormous labour, but resulting in the discovery of an element—which they called radium—having a radio-activity about a million times greater than that possessed by uranium. Some tons of pitch-blende only furnished a few decigrams of a salt of radium, of which of course only a fraction was pure radium. There are only three radio-active elements known, *viz.* radium, thorium, and uranium; *polonium* discovered by Madame

Curie and *actinium* by Debiere are probably only transition products of radium.

Each of the three radio-active elements emits three kinds of radiation, known as α , β , and γ radiation, of which we proceed to give some of the properties. The α radiation consists of positively charged particles moving with a velocity $\frac{1}{2}$ that of light, and having a mass about twice that of the hydrogen atom. They may be deviated from a straight-line course, but only to a small extent, by a powerful electric or magnetic field. They have small penetrative power, being stopped by 0.1 mm. of mica or aluminium foil, or a few millimetres of air at atmospheric pressure. Their photographic action is comparatively small, but they ionise the gas through which they pass to a powerful extent, this effect being detected by a sensitive gold-leaf electro-scope of special construction. The energy of the α rays, measured by their ionising power, constitutes 99 per cent. of the total energy radiated.

The β radiation consists of negatively charged particles. Like cathode rays (981), with which, perhaps, they may be identified, the β rays are readily deflected by a magnetic or electric field. They are projected with a velocity varying from .6 to .9 that of light, that is, their velocity is about 10 times as great as that of the α rays. They exhibit great penetrative power; 5 mm. of aluminium or 2 mm. of lead are necessary to stop them. They have a mass of about $\frac{1}{1000}$ that of an hydrogen atom, and are similar to those which constitute the cathode rays, and to the negative ions shot out by metals in vacuo under the influence of violet light.

The γ rays have still greater penetrative power; they will pass through 7 cm. of lead, 19 cm. of iron, or 150 cm. of water before their intensity is reduced to 1 per cent. of its original value. They are not deflected by a magnetic or electric field, and in some respects they resemble Röntgen rays, but at present not much is known about them.

In 1900 Rutherford found that the radiation from thorium is accompanied by the emission of a gaseous substance having temporary radio-activity. This he called an *emanation* to distinguish it from the radiations already described. The emanation diffuses slowly through the air, and acts as an independent source of straight line (α , β , γ) radiation, gradually decaying with time. A similar emanation is given off by radium, but not by uranium. Emanations are chemically very inert; they may be bubbled through liquids, condensed at the temperature of liquid air and again volatilised by a rise of temperature. From measurements of the rate of diffusion the density of the radium emanation was found to be about 100 times that of hydrogen.

Solid bodies with which the emanations come in contact themselves acquire temporarily radio-active properties. This is known as *excited* or *induced radio-activity*. The matter which produces the excited radio-activity (which is not the emanation, though it is produced from it) may be dissolved from the bodies to which it has attached itself by certain acids. The emanation itself is not soluble.

Emanations are emitted much more freely from compounds of the radio-active elements in solution than in the solid form, and the rate of emission is largely affected by physical conditions, such as temperature. Rutherford showed that these differences are apparent only, and that the emanating power of a radio-active substance depends only on the mass of the element

present whatever the state of combination in which it exists. In a solution the emanation escapes as fast as it is formed ; in the solid it is occluded or stored up, and when the solid is dissolved the imprisoned emanation is set free. The same result follows when the solid is heated.

Rutherford and Soddy obtained from thorium salts substances whose radio-activity was much greater than that of the original salt. If ammonia is added to a thorium solution the thorium is precipitated. The precipitated thorium has lost a large part of its activity, and now emits *a* rays only ; the filtrate, which is chemically free from thorium, is much more active, weight for weight, than the thorium from which it was obtained. This active material was called *Thorium-X*. A month later it was found that the thorium-*X* was no longer active, while the thorium had completely regained its activity. More careful study showed that the thorium-*X* lost half its activity in four days, and that exactly as one gained the other lost its activity, and that the sum of the activities of the thorium and thorium-*X* was constant. Crookes had previously found that an active uranium compound may be chemically separated into two parts, one of which (uranium-*X*) was very radio-active, emitting *all* the β rays, while the other (which contained all the uranium) was nearly inactive, emitting only *a* rays. The latter regained as the uranium-*X* lost its activity. The process could be repeated indefinitely. No similar separation can be effected in the case of radium. On the other hand uranium gives off no emanation.

According to Rutherford thorium is constantly manufacturing at a uniform rate a substance, thorium-*X*, which is the radio-active constituent of thorium ; its radio-activity gradually dies away. The normal radio-activity of a thorium compound is due to a state of dynamical equilibrium in which the increase of activity due to the production of fresh thorium-*X* just balances the loss due to the fading away of the thorium-*X* previously produced. The thorium-*X* is only active for about a week.

Ramsay and Soddy have detected, by means of the spectroscope, the presence of helium in the gases evolved from a sample of radium which had been kept as a solid for some months. The spectrum of helium was invisible when the emanation was first collected and examined, but it soon appeared and increased in intensity with lapse of time. It has been concluded from this, and from other experiments made by Curie and Dewar, that helium is one of the final products obtained by the disintegration of the radium atom.

The energy involved in a given amount of radio-active change is enormous, certainly a hundred thousand times as great as that involved in the most energetic chemical action known. Curie and Laborde showed that a radium salt is always at a higher temperature than its surroundings. Using 7 grm. of pure radium bromide, they found by a mercury thermometer that the temperature of the radium was 3° C. above that of the surrounding air. By means of a Bunsen's calorimeter they showed that 1 grm. of pure radium emits a quantity of heat of about 100 calories per hour. Thorium and uranium are much less energetic ; the radio-activities of uranium, thorium, and radium being approximately as 1 : 1000 : 1,000,000. Of the total energy of radiation of radium 99 per cent. is due to *a* rays.

Sir Wm. Crookes has devised a simple apparatus called a *Spinthariscopescope*, for exhibiting the action of radium on a phosphorescent zinc sulphide

screen. A small piece of metal which has been dipped in a radium solution is fixed a fraction of a millimetre from the screen. When this is examined by a lens, brilliant scintillations are seen on the screen due to the bombardment of the screen by the α radiation.

The disintegration theory of radio-activity is now commonly held, since it explains the facts better than any other. According to this theory, the atoms of radio-active elements undergo spontaneous disintegration; each disintegrated atom passes through a succession of well-marked changes, accompanied in most cases by the emission of α rays. These changes are few and comparatively simple in the case of uranium. A uranium salt emits α , β , and γ rays, but not emanation; by chemical means a product can be separated from it (uranium- X) which gives out β and γ rays, the uranium emitting only α rays. The uranium- X gradually loses its radio-activity as the uranium regains that which it had lost, the sum of the two radio-activities being constant. In the case of radium the changes are more numerous but equally well marked. Radium emits α , β , and γ rays, and an emanation. When the emanation is separated from the radium compound (by solution or heat) the remaining radium emits only α particles, the emanation passing by two stages into a condition in which α , β , and γ rays are emitted. Excited radio-activity on the walls of the containing vessel is due to a product of the emanation. This product is soluble in some acids, not in others, and is volatilised at a white heat. There is evidence of further changes before the final products are reached. Helium is very likely one of the final products.

Many ordinary substances are radio-active to a slight extent, for example rain water, water from deep wells, air from caves, &c. It is probable that all bodies are slightly radio-active and emit ionising radiations, but that emanations are evolved to an appreciable extent by a very small number of elements.

CHAPTER XII

MAGNETO- AND DYNAMO-ELECTRIC MACHINES

985. **Alternating currents.**—We have seen that when a coil such as that represented in fig. 976 is rotated in a magnetic field, induced currents are developed in it. When the terminals of the coil are connected to a galvanometer and the circuit then closed, the current produced follows the same variations as the E.M.F., since the resistance is constant, or it would do so if there were no such thing as self-induction. The effect of self-induction is to cause the current to lag behind the electromotive force. Self-induction opposes any change in the current, retarding both its rise and fall, and is a maximum when the current is zero, and zero when the current is a maximum. It thus comes about that the current reaches its maximum a little after the E.M.F. has passed *its* maximum, the *lag* being constant throughout the cycle. Such currents are called *alternate* or *alternating* currents, and are, when their changes follow the sine law, further known as *sinusoidal* currents.

Suppose the field to be horizontal and the coil to rotate uniformly about a horizontal axis perpendicular to the lines of force. The E.M.F. at any moment is equal to the rate at which the lines of force are being cut, or what comes to the same thing, the E.M.F. is equal to the rate of variation of the enclosed lines of force. Now when the coil is vertical, although the number of lines enclosed is a maximum, they are (at the moment of verticality) undergoing no variation; hence the E.M.F. is zero. On the other hand, when the coil is horizontal it encloses (at the moment) no lines; just before this position is reached the lines are passing through in one direction, just after it is left they pass through in the opposite direction, and it is easy to show that the rate of change is greater in this position than in any other. Thus, as the coil rotates the induced E.M.F. increases from zero to a maximum in the first quadrant, and falls to zero again in the second quadrant; as the coil turns through the third and fourth quadrants the same changes occur, but with reversed sign. These changes are represented graphically by the sine curve XY of fig. 45, and the E.M.F. at any moment is proportional to the sine of the angle the coil has turned through from the vertical. If e represents the E.M.F. when the coil has turned through an angle θ , and E the maximum E.M.F.,

$$\begin{aligned} e &= E \sin \theta \\ &= E \sin \phi t \quad (59), \end{aligned}$$

if ϕ is the uniform angular velocity with which the coil is rotating, and t the time measured from the zero position.

It might be thought that the maximum value of the current would be

equal to the maximum value of the E.M.F. divided by the resistance of the circuit, in accordance with Ohm's law. But this is not so; self-induction, by continually opposing any change in the current, gives rise to what is equivalent to an extra resistance, which is compounded with the true or *ohmic* resistance, the combination being called the *impedance*. The impedance of a circuit may be shown to be equal to $\sqrt{R^2 + \dot{\phi}^2 L^2}$, where R is the ohmic resistance, L the inductance, and $\dot{\phi}$ the angular velocity of the rotating coil; $\dot{\phi} = 2\pi n$ where n is the number of revolutions per second. The E.M.F. and current vary from 0 to a maximum; the mean or average value of either may be shown to be equal to $\frac{2}{\pi}$, or .637 of its maximum. If E is the maximum value of the *impressed* E.M.F., that is, the E.M.F. applied to the circuit, and ϕ the angle by which the current lags behind the E.M.F., we shall have

$$C = \frac{E}{\sqrt{R^2 + \dot{\phi}^2 L^2}}, \text{ and } \tan \phi = \frac{\dot{\phi} L}{R};$$

also, average value of current = $\frac{\text{average value of E.M.F.}}{\text{impedance}}$.

Alternate currents are usually measured by some form of electro-dynamometer (896), since an ordinary suspended needle or suspended-coil galvanometer would be useless for the purpose. The angle through which the torsion head of the electro-dynamometer must be moved to bring the movable coil to its initial position varies as the square of the current, and therefore is the same for a given current whether it is positive or negative. If the current is sinusoidal, the instrument indicates the mean value of its square, and the square root of the angle through which the torsion head has been turned is proportional, not to the mean current, but to the square root of the mean value of its square, called the *square root of mean square*. This is the *effective current*, and is equal to the continuous current which would give the same instrumental reading.

986. **Magneto-electric machine.**—After the discovery of magneto-electric induction, several attempts were made to produce an uninterrupted series of sparks by rotating a coil in a magnetic field. Apparatus for this purpose were devised by Pixii and Ritchie, and subsequently by Saxton, Ettinghausen, and Clarke. Fig. 999 represents that invented by Clarke. It consists of a powerful horseshoe magnetic battery, A , fixed against a vertical wooden support.

In front of this is an electromagnet, BB' , whose soft-iron cores are connected by the iron yoke V , while a similar plate of brass joins the pole-ends of the cores and forms a support for the rotating spindle. This spindle terminates at one end in a commutator qo , and at the other in a pulley connected by an endless band to the driving wheel.

The wire of the electromagnet is, of course, wound in opposite directions on the two bobbins B and B' ; one of its free ends is joined through the spindle to the brass ferrule o , and the other to a ferrule q which is insulated from the axis. The springs b and c carry off the induced current; they are always in connection with the ends of the wire if they press respectively against the brass rings o and q . The spring a is only used when it is desired to effect a sharp break in the circuit.

When the electromagnet turns, its two branches become alternately magnetised in opposite directions under the influence of the magnet A. Suppose in the position shown in the figure, B is opposite the north pole of the magnetic battery A, the lines of force leaving this pole pass through the air-gap, the core of B, the yoke V, the core of B', and the air-gap to the south pole of A, and then through the magnet A to the starting-point, so completing the magnetic circuit. The electromagnet in this position contains more lines of force than in any other; as soon as it begins to move, say, anti-clockwise, the number of lines diminishes, and when it has turned through 90° , so that the yoke V is vertical, no lines pass through it. When

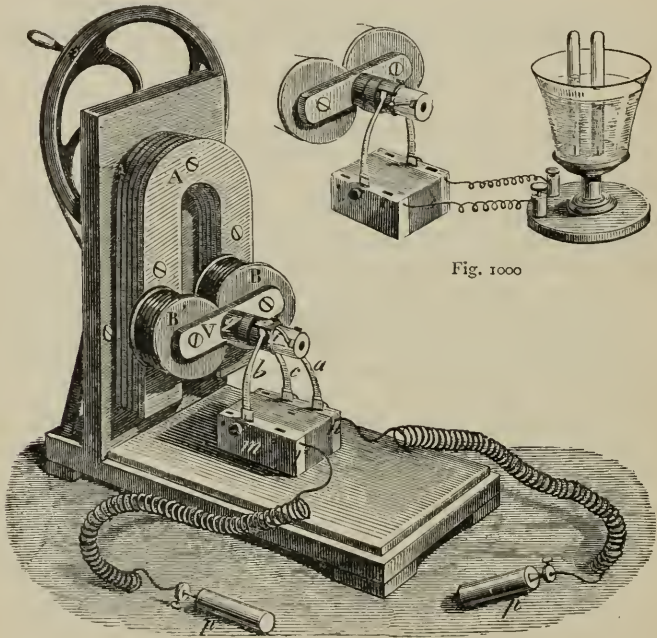

Fig. 1000

Fig. 999

this position is passed the number of lines begins to increase, but in the opposite direction, and reaches a maximum when another quarter turn has been made. But a little consideration will show that the direction of the electromotive force in the wire on the bobbins is the same throughout this half-turn, its amount being zero in the two horizontal positions, and a maximum in the vertical. During the second half of the revolution exactly the same changes recur, but the sign of the induced E.M.F. is reversed. If the circuit is completed by joining the springs *b* and *c* by a conductor, we have alternating currents produced in it which are approximately sinusoidal. A galvanometer included in the circuit will show little or no deflection, since the flow of electricity through it is as much in one direction as in the opposite.

For physiological effects copper spirals are fixed at m and n , and the experimenter, holding the handles p and p' in his moistened hands, feels a sharp shock at each half-revolution, the intensity of which depends on the velocity of rotation. The muscles contract with such force that they cease to obey the will, and the hands can with difficulty be detached. With an apparatus of large dimensions a continuance of the shock is unendurable.

By the use of a *two-part commutator* the current may be *rectified*—that is, the direction may be changed at every half-revolution, so that, although the current is not constant, it has always the same direction. It consists of a brass ferrule on the insulated axis, split diametrically, so as to be reduced to two half-cylinders insulated from each other, and from the axis of rotation (fig. 1000). The two parts of the commutator are connected to the two ends of the wire forming the electromagnet. It will be seen from fig. 1000 that, as the coils rotate, each spring touches one part of the commutator during half the revolution, and the other part during the second half; and the gaps are so placed on the axis that the change of contact of the springs from the one to the other takes place at the moment when the direction of the current is changing, that is, when V is horizontal. Fig. 1000 shows the arrangement for the decomposition of water.

The principle of Clarke's machine was subsequently utilised in large magneto-electric machines for the production of the electric light, the machines of Nollet and de Meritens being well-known examples. In these the single magnetic battery and pair of coils of Clarke's machine were replaced by a considerable number of batteries arranged on a circular or cylindrical frame, with a corresponding number of coils with iron cores. In modern machines permanent steel magnets are dispensed with, and the necessary magnetic fields are produced by electromagnets, called *the field magnets*, actuated from some independent source, either a battery or more generally a direct-current dynamo.

Fig. 1001 is a diagrammatic picture giving the arrangement of the field magnets and rotating coils, called the *armature*, in a type of alternating current machine adopted by Siemens. The magnetic field is produced by two sets of cylindrical electromagnets, whose cores are securely fixed to two circular cast-iron frames. Three pairs of coils are shown in the figure, and the coils are connected in such a way that the exciting current makes the ends of the cores which face each other of opposite polarity, as well as those which are side by side on the same ring. Thus, the lines of force from any N pole pass to the S pole opposite, as well as to S S poles on either side of N.

The armature coils, shown in the figure as circular turns of wire, are in reality pear-shaped coils wound over wooden cores, and arranged on the circumference of a wheel which is mounted on the shaft and can be rotated at any desired speed.

The coils in rotating cut through a succession of strong magnetic fields, alternating in direction. Since in any adjacent pair of coils the fields are opposite, the coils must be wound as shown in the figure, in order that the currents induced in neighbouring coils may be in the same direction.

Suppose the direction of rotation of the armature coils (fig. 1001) is anti-

clockwise, then the coils are just leaving the pole-pieces. In each coil the number of enclosed lines is diminishing, and, therefore, applying the rule of art. 960, it will be found that the direction of the induced current is that shown in the figure. The E.M.F. increases until each coil reaches a position midway between the pole-pieces, the number of enclosed lines being then a minimum; when the coil has reached the next pole-piece the E.M.F. is zero. The number of alternations is equal to the number of coils on either frame, and the change of sign takes place when the armature coils are just over the pole ends of the field magnet.

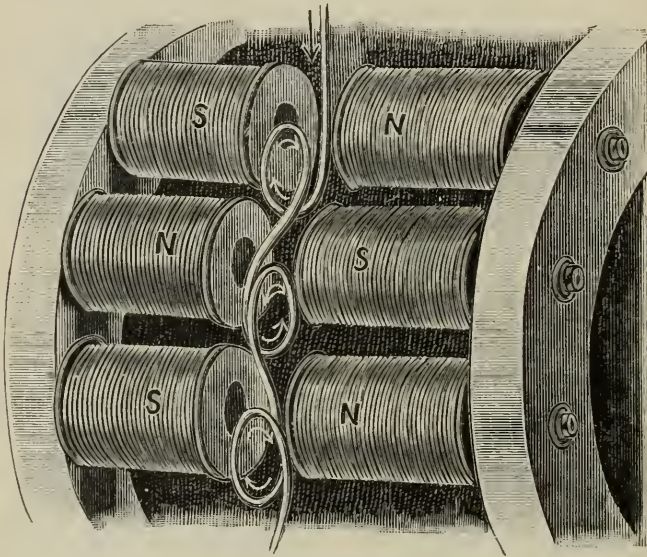

Fig. 1001

(From Slingo and Brooker's 'Electrical Engineering')

The induced E.M.F. varies, as we have seen, with the ordinate of a sine curve; its average value, since it depends upon the rate at which the armature coils cut the lines of force due to the field magnets, must vary with the number of lines emanating from each field pole, and with the number of alternations per second, and this latter factor is equal to the number of revolutions per second multiplied by the number of pairs of poles. If, then, N is the number of lines emanating from each pole, p the number of pairs of poles, and V the number of revolutions per second, the average E.M.F. is proportional to NpV .

987. **Siemens's armature.**—Werner Siemens devised a cylindrical armature for magneto-electric machines, in which the insulated wire is wound lengthwise on the core, instead of transversely, as is usually the case.

It consists of a soft-iron rod or cylinder, AB (fig. 1002), from one foot to three feet in length. A deep groove is cut in this cylinder and on the ends,

in which is coiled the insulated wire, as shown in section in fig. 1003. To the two ends of the cylinder, brass discs, E and D, are secured. With E is connected a commutator C, consisting of a steel sleeve cut obliquely into two parts which are insulated from each other and from the axis of rotation, and connected respectively with the two ends of the wire. On the other disc is a pulley, *p*, round which passes a cord, so that the bobbin revolves very rapidly on the two pivots.

If the coil is made to rotate rapidly between the opposite poles of magnetised masses, then as the segments A and B become alternately magnetised and demagnetised, their induction produces in the wire a series

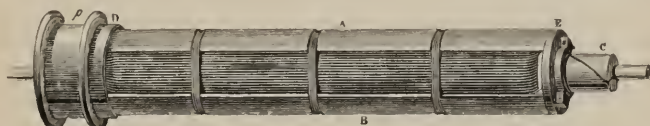

Fig. 1002

of currents alternately positive and negative, as in Clarke's apparatus (986). When these currents are collected in a commutator which adjusts them—that is, sends all the positive currents on one spring and all the negative on another—these springs become the positive and negative terminals of a direct-current machine.

The magnetic field in which the armature rotates may be produced by an electromagnet as well as by permanent steel magnets. Fig. 1003 shows a section of such an arrangement; AA are the iron plates or cases on which the wire is wound, and CC the iron pole-pieces separated by non-magnetic metal, OO.

988. **Dynamo-electric machines.**—A great advance was made by the discovery of the principle of the reaction of a current on itself—a discovery made by Dr. Werner Siemens and Sir C. Wheatstone independently of each other and almost simultaneously. When an armature is rotating between the poles of a horse-shoe electromagnet through the coils of which no current passes, since there is no magnetic field there will be no induced

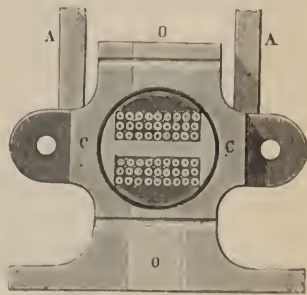

Fig. 1003

E.M.F. in the armature. But iron which has once been magnetised almost always retains some trace of residual magnetism, and consequently there will *generally* be a magnetic field—possibly very feeble—between the poles of an electromagnet. The dynamo principle consists in connecting the armature circuit and the field-magnet circuit so that any current developed in the armature may pass, wholly or in part, through the field-magnet coils. The result will be that any current induced in the armature, due to the slight residual magnetism of the field magnets, will also pass through the field-magnet coils and strengthen the field, thereby increasing the induced

current, which again reacts on the field, and so on. Thus a trace of residual magnetism is sufficient to start the apparatus, and the current then goes on increasing as the rotation is continued, and is indeed only limited by the limit to the magnetisation of the iron.

Apparatus which transform mechanical energy into the energy of electric currents, or conversely, are known as *dynamo-electric machines*, or briefly *dynamos*. The name was originally restricted to self-exciting machines—that is, to those in which no permanent magnets, or extraneous means of excitation, were employed. It is now used without limitation for electric generators or motors.

Dynamo machines are called *dynamo-electric generators* when they convert mechanical into electric energy, and *dynamo-electric motors* when they are arranged to produce mechanical power at the expense of an electric current.

989. **Gramme ring.**—We have seen how, by the use of a two-part commutator, the alternate currents developed by the rotation of a coil of wire in

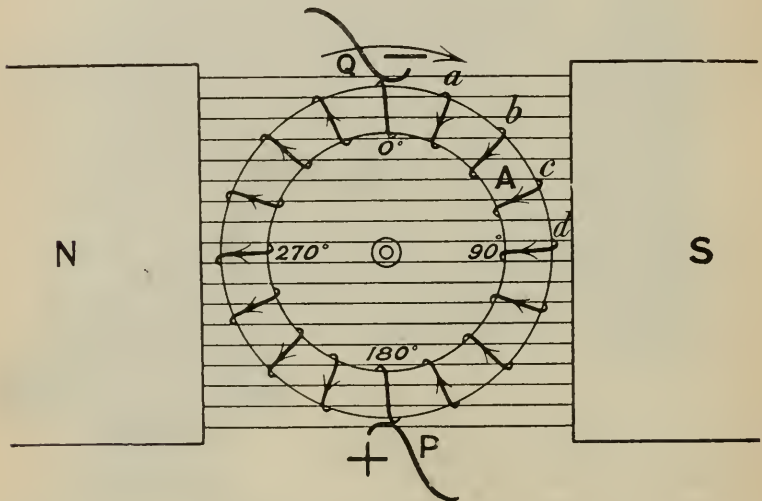

Fig. 1004

a magnetic field may be rectified. But though the current is thus rendered unidirectional, it is of very varying strength, changing from zero to a maximum, and again to zero, twice over in each revolution. By the application of a principle discovered by Pacinotti in 1862, and subsequently and independently by Gramme, it is possible to obtain from a revolving coil a practically continuous and steady current. One form of armature in which the principle is embodied is known as a Gramme ring.

The principle of the Gramme ring will be understood from the following explanation:—Let N and S (fig. 1004) be the poles of the field magnets, and we will suppose the field to be uniform, as represented by uniformly

spaced lines drawn from N to S. A is a wooden ring wound with an endless wire, capable of turning about an axis through its centre at right angles to the plane of the paper, with uniform angular velocity. Further, let us suppose the wire to be bare copper wire, the successive turns being close together, but not touching, and sufficiently insulated from each other by the wood on which they are wound: for simplicity, only 16 turns are represented in the figure. Each convolution as it rotates will have an electromotive force induced in it, the magnitude of which depends on its position in the field; in the turns near 0° and 180° it will be very small, and in those near 90° and 270° it will be a maximum, since there the lines of force are cut most rapidly. With a right-handed rotation of the armature the direction of the E.M.F., and therefore of the currents in the successive turns, will be as indicated in the figure. It will be seen that there results a current flowing downwards from Q to P through the right-hand half of the armature, and an equal current also flowing downwards on the left-hand side. These are opposed to each other and hence there is no resultant current. But if P and Q are springs pressing against the wire at 0° and 180° , and are connected to an external circuit, the two currents unite into a single current which flows out into the external circuit at P and returns to the armature at Q. This current is practically continuous, the fluctuations from perfect steadiness becoming smaller and smaller as the number of coils on the ring is increased.

Since the induced E.M.F. depends upon the rate of cutting lines of force, it is clear that a very great advantage will be gained by winding the wire on an iron core, since under given conditions the magnetic flux is very much greater through an iron than through a non-magnetic core. The wire is insulated, and the springs or brushes for carrying off the current, instead of touching the periphery of the ring, are arranged to rub against a series of metal strips, called *commutator segments*, arranged on the rotating shaft and connected to the successive turns or coils on the ring. Fig. 1005 shows the arrangement of a real Gramme ring. The core is not solid, but consists of a coil of a number of turns of varnished soft-iron wire, and consequently the changes in its magnetisation which take place are far more rapid, and the heating effect due to these rapid changes is less than would be the case if it were one solid ring; the wire is continuous, and the two ends are soldered together.

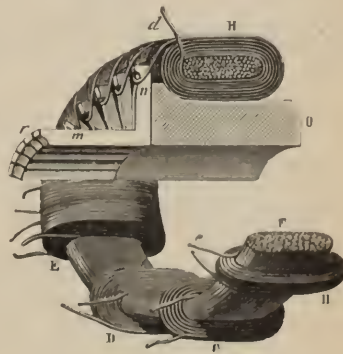

Fig. 1005

On this core are wound the coils B, C, D, &c.; they are connected to the copper commutator segments, *mn*, to each of which are soldered the wires of two successive coils, so as to form a continuous whole. The commutator segments are insulated from each other by mica, and are fixed on

a wooden block *o*, mounted on the axis of rotation. The commutator segments form a sheath about this axis, and two flat brushes of copper wire are in contact with the upper and lower parts of this sheath, and receive the currents which originate in the coils.

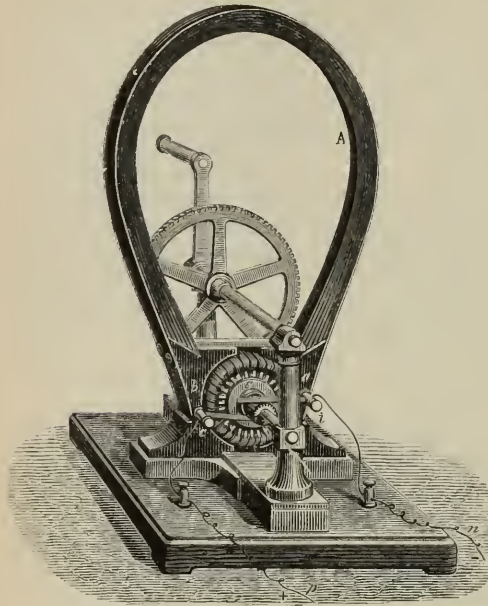

Fig. 1006

Fig. 1006 shows a small hand machine fitted with a Gramme ring armature, the field being excited by a set of Jamin's permanent magnets. The points of contact of the brushes, it will be seen, are on a line at right angles to the magnetic field.

990. Displacement of the brushes. Angle of lead.—Fig. 1007 represents the direction of the lines of force in the simple case of a Gramme ring when rotated on *open* circuit. It will be seen how they almost entirely pass through the ring. The line AB is then the position

in which the brushes should be placed in accordance with the explanation given.

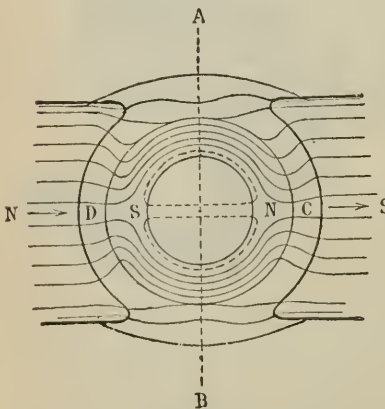

Fig. 1007

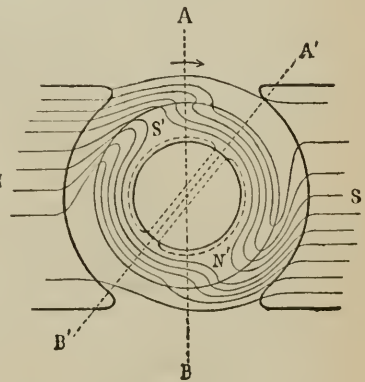

Fig. 1008

When the armature is rotated on *closed* circuit and the brushes are in the position corresponding to the ends of AB, sparks pass between the brushes

and the contact pieces, which would speedily destroy them. It is found that by displacing the brushes in the direction of the motion a position is found, varying with the strength of the current, in which the sparking disappears.

This is attributable to the fact that the total field is now the resultant of the original field and that due to the magnetisation of the core of the armature by the current flowing through it. The effect of the composition of the two fields is a displacement of the original lines of force (fig. 1008), and the points in which the induced electromotive force is null are moved into the position A'B'. The angle through which the line of brushes must be displaced so as to prevent sparking is called the *angle of lead*.

991. **Classification of dynamo machines.**—The principal types of dynamo machines are depicted in figs. 1009-1012, originally due to Prof. Sylvanus Thompson. The field magnet is represented as a horseshoe with long limbs, on which the exciting wire is wound, and an iron yoke. The iron pole-pieces are curved so as to embrace as closely as possible the rotating armature. The latter is not shown in the figures, but the commutator, with its segments and contact brushes, is indicated. Fig. 1009 represents a machine in which the current from a battery or separate machine excites the field magnets, and this type is known as the *separately excited machine*.

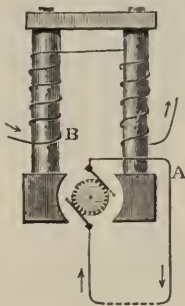

Fig. 1009

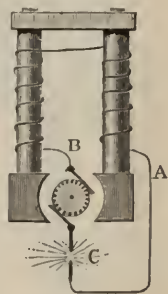

Fig. 1010

In a separately excited, as in a magneto, machine the E.M.F. is proportional to the speed of the revolution, and for a given speed, E being constant, the current varies inversely as the resistance.

Fig. 1010 represents the original form of the dynamo; the current from the armature passes directly from one brush into the wire of the field magnet, from thence into the external circuit, returning to the armature by the other brush; such machines are said to be *series wound*. There is no D.P. between the terminals of a series wound dynamo on open circuit. When the terminals are joined by a resistance, or in technical language when a load is applied, the machine quickly excites, and the E.M.F. rises to its proper value for that load. As the resistance increases the current falls, both directly and also in consequence of the diminished E.M.F. caused by the weakening of the field; and when the resistance exceeds a certain limit the machine does not excite. On the other hand, when the external resistance decreases, there is a limit to the increase of the current due to saturation of the field magnets and other causes. Series wound dynamos are not used for charging accumulator cells, since there is always a danger that, on a temporary break in the circuit or slackening of the speed of running, the (back) E.M.F. of the cells may overpower that of the machine, reverse its magnetism and drive it backwards.

A third type is that represented in fig. 1011, and is known as the *shunt wound dynamo*; the current through the armature divides at B, one portion

passes through the long and thin wire of the field magnet, and the other through the external circuit—for instance, an electroplating bath.

Thus the external circuit and the shunt coils are in parallel and share the current produced in the armature. The shunt coils have a high resistance as compared with the field-magnet coils of a series dynamo. When the machine is on open circuit, the armature and shunt are in series with each other, and under these conditions the D.P. at the terminals is a maximum for a given speed. When the poles are joined by a resistance which is gradually diminished from a high value, the D.P. diminishes and the current increases up to a certain limit, after which it again diminishes and tends to vanish when the load is very large. Near the limiting value a change in the external resistance produces only a slight effect on the current, for increase of resistance throws more current into the shunt coils, and therefore strengthens the field and with it the E.M.F.

The *compound wound* dynamo is represented in fig. 1012. There are two field-magnet coils, one of low resistance, the other of relatively high resistance, connected respectively in series with, and in shunt with, the external circuit. The coils may be wound in such a way that the machine may give either constant pressure or constant current within certain limits of load. A constant pressure machine is used for feeding pressure lamps in parallel. If a number of these lamps are removed, the resistance in the external circuit is increased, and the current would be lessened, partly from Ohm's law, and partly from the weaker magnetisation whereby the difference

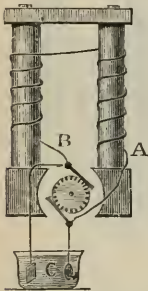

Fig. 1011

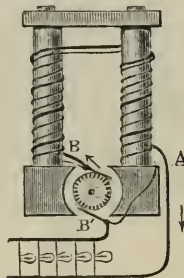

Fig. 1012

of potential would be less, and possibly to such an extent that the lamps would not glow; but with the compound winding a greater proportion of the current now passes through the shunt wire, and thus the field is strengthened. By a suitable choice of the resistances, and the relative number of turns of the wires, the increase of the magnetisation can be made so great that the diminution in the difference of potential is thereby compensated.

992. **Drum armature.** **Siemens's dynamo-electric machines.**—There is another type of armature used in direct-current machines, known as a *drum armature*. The core is a cylinder or drum formed of a number of thin iron discs or washers insulated from each other, and on this the wire is wound longitudinally, crossing over at the ends, each turn being shifted slightly on the drum with regard to the preceding one. The wire forms a closed circuit, and as in the ring armature, the ends of each turn or group of turns are brought to commutator segments ranged on the axis of rotation. The principal difficulty in winding drum armatures is to carry over the wire at the ends of the drum in such a way that the end faces may not be blocked up with wire and insulating material, and ventilation prevented, and many ingenious plans have been devised for overcoming this difficulty.

Fig. 1013 represents the essential features of one of the small-sized vertical machines made by Siemens & Co., a characteristic of which is the drum armature. The poles of the field magnets MM' , MM' are joined together, north to north and south to south, by massive pieces of soft iron, bent so as to almost completely encircle the armature; the front pieces, N , form the north pole of the combined field magnet, and similar pieces behind form the south pole, and the lines of force run horizontally from front to back. D is the armature, and C the commutator segments on which rest two pairs of brushes, the plane of commutation being nearly vertical. One advantage of the drum armature is that all the turns of wire on the drum cut all the lines of force which pass through the armature core. Drum armatures are now much more used than ring armatures, especially in slow-speed dynamos. The resistance from brush to brush, as in the case of the Gramme ring, is only one-quarter of the actual resistance of the wire on the armature.

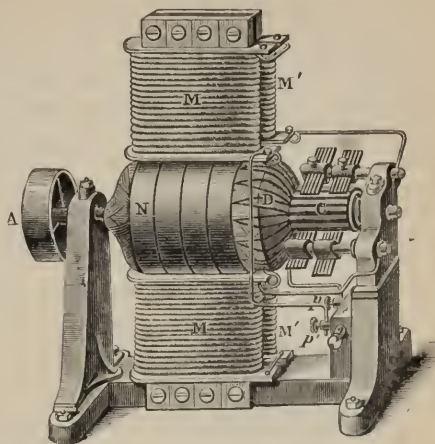

Fig. 1013

993. **Motors.**—An electric motor is a machine for converting electric into mechanical energy. Any dynamo-generator may serve as a motor; that is, if a current from a battery or other source is allowed to pass through its armature and field magnets, the armature will rotate. In the case of a series wound machine (fig. 1010), the direction of rotation is opposite to that in which the armature must be driven in order to produce a current in the same direction. This will be clear from a consideration of fig. 1008, for as in the *generator* the south pole, S' , of the armature is urged away from the north pole and towards the south pole of the field magnet, work being done against magnetic forces, so in the machine used as a *motor* the direction of the current being the same, S' , will be attracted towards N , and the direction of rotation will be reversed. If the machine is shunt wound, on the contrary, and a battery is inserted in the external circuit to produce a current in the same direction as that due to the action of the machine as a generator, the armature will rotate in the *same* direction as before, since the polarity of the field magnets is reversed.

If a battery or dynamo is connected up with an ammeter and a motor whose armature is prevented from turning, the current, C , is equal to $\frac{E}{R}$ where E is the applied E.M.F., and R the resistance of the circuit. When the armature is allowed to rotate, the current, as indicated by the ammeter, falls, owing to the back E.M.F. set up in the motor, and the diminution of current is greater, the greater the speed; for the armature

cannot rotate without developing an electromotive force, and the direction of this must, by Lenz's law, be such as to tend to stop the motion. Let e denote this back E.M.F. for a given speed, then $C = \frac{E - e}{R}$. The power supplied from the source = CE watts, of which an amount equal to C^2R is absorbed in heat in the circuit; the remainder, which from the above equation is equal to Ce , represents the power absorbed by the motor and converted into mechanical power. The *efficiency* of the motor = $\frac{Ce}{CE}$ or $\frac{e}{E}$, and is greater the more nearly this fraction is equal to unity; that is, the smaller the current. The maximum amount of energy in a given time will be obtained from the motor when Ce or $\frac{e(E - e)}{R}$ is a maximum. Now, since the sum of the two factors e and $E - e$ is constant, their product will be a maximum when they are equal to each other, or when $E - e = e$, or $e = \frac{E}{2}$. Thus, the maximum efficiency of a motor must be distinguished from its maximum rate of working.

994. **Transformers.**—Ruhmkorff's coil, as we have seen, is an arrangement by means of which we can transform electricity of low into electricity of high potential. There is no creation of electricity; the energy produced in the secondary circuit is produced at the cost of that in the primary. The apparatus acts, in short, as a *transformer* or *converter*, and it is reversible, for if we connect the long thin wire with a source of electricity yielding alternating currents at high potential, we get alternating currents in the short thick wire, of low potential but of much greater strength. The functions of the wires are reversed in this case; the thin long wire is the primary and the short thick wire the secondary. This modification of the principle of Ruhmkorff's coil is of great practical importance in the transmission of electric energy.

One type of transformer, represented in fig. 1014, consists of a closed iron ring, or preferably a bundle of soft-iron wires or strips, so as to hinder the formation of eddy currents (964). In either case the magnetic circuit is closed, the primary wire AB is coiled on this, and over it the secondary, ab , both carefully insulated; or the two sets are coiled separately in individual sections, as shown in the figure.

In another type, represented in fig. 1015, the primary and secondary wires are wound together and form the core, while on this is coiled in a continuous circuit at right angles iron wire or strips, coated on the surface with iron oxide, which, being an insulator, tends to prevent the formation of eddy currents.

It is of great importance that the insulation of transformers be good, more especially when, as in recent times, it is requisite to transform potentials of 40,000 to 50,000 volts, or even more. In such cases the whole transformer is placed in oil, which penetrates the pores and insulates admirably.

The chief requirement in any transformer is that it shall effect the transformation of electric energy without great loss. In the ideal case the transformed electric energy would be equal to the original, which, however, is impossible; for in the first case heat, according to Joule's law, is produced

both in the primary and the secondary wire, and this is lost as far as useful effect is concerned. Then, further, some energy is consumed in eddy currents, and, moreover, the magnetisation and demagnetisation of the iron core or envelope represent a loss of energy, which is spoken of as the loss by hysteresis (907).

Owing to all these causes, the power in the secondary wire is always less than that in the primary, and the ratio of the two is called the *efficiency*. In the most improved modern forms an efficiency of 96 per cent. is attained. The efficiency is greater when the transformer works under a full load. The magnetisation then oscillates within narrower limits, and the losses due to hysteresis are smaller.

In the transmission of power from one place to another, transformers play an important part. Suppose a source of power available of 50,000 watts, for example, and that this is to be transmitted in the form of

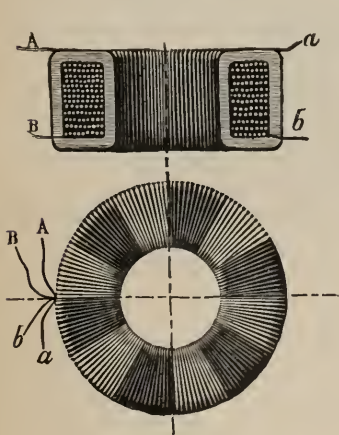

Fig. 1014

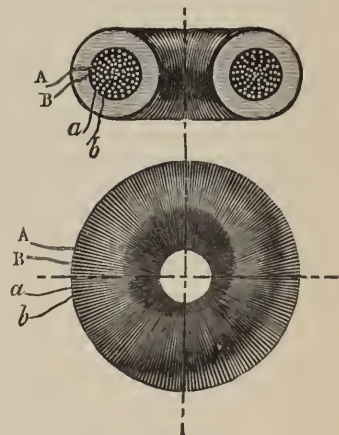

Fig. 1015

electric power to a certain distance, there to be utilised. Since a watt represents the product of two factors, a volt and an ampere, we may vary these factors, which make up the total, in any way we like. We may transmit it in the form of a strong current of low electromotive force, or of a weak current with very high electromotive force. Thus, for instance, we can transmit the above quantity as a current of 500 amperes under a pressure of 100 volts. But for this purpose the resistance of the conductor through which the current passes must be small, which necessitates that it have a large section and consist of very good conducting material—that is, of copper.

The energy could, however, also be transmitted in the form of a weak current, say of 10 amperes, under a pressure of 5000 volts; the conductor required for this purpose might be very much thinner, and therefore far less costly.

By increasing the number of coils of a dynamo machine, and the speed of rotation, currents may be produced of very high electromotive force. But in practice it is found that a certain speed of rotation cannot be

exceeded, and, moreover, the difficulty of insulation in the machines themselves is greatly increased; the electricity is apt to discharge in the body of the machine itself, and thus destroy the insulation. In practice it is not safe to go beyond 2000 volts.

Here comes in the great utility of transformers. Suppose the generator to produce a strong electric current of low potential, which is then passed into a suitable transformer and, on the principle $CE = C'E'$, is converted into a small current of high electromotive force. This weak current is then transmitted along a thin wire to the place where it is to be utilised, where it again enters a transformer, and is changed into a current of the desired strength.

The first great progress made in this direction was at the Electric Exhibition of 1891, at Frankfort-on-the-Main, in which mechanical power was transmitted from Lauffen-on-the-Neckar through a distance of 110 miles with a loss of 28 per cent. The water-power available at Lauffen worked a turbine producing 300 horse-power; this generated an enormous current of 4000 amperes at 55 volts, or 220,000 watts; by means of copper rods over an inch in diameter this current was passed into a transformer, where it was changed into a current of 8 amperes at 27,000 volts. This small current was transmitted through copper wires $\frac{3}{8}$ of an inch in diameter, to Frankfort, where it again entered a transformer, in which its electromotive force was transformed down to 100 volts.

The chief practical difficulty in the transmission of power economically seems now to be one of insulation.

CHAPTER XIII.]

DIAMAGNETISM

995. **Diamagnetism.**—Coulomb observed, in 1802, that magnets act upon all bodies in a more or less marked degree : this action was at first attributed to the presence of ferruginous particles. Brugmann also found that certain bodies—for instance, bars of bismuth—when suspended between the poles of a powerful magnet, do not set *axially* between the poles, that is, in the line joining the poles, but *equatorially*, or at right angles to that line. In other words, while a magnetic substance such as iron sets *along* the lines of force of the magnetic field, a bar of bismuth sets *at right angles* to the field. This phenomenon was explained by the assumption that the bodies were transversely magnetic. Faraday made the important discovery in 1845 that *all* solids and liquids which he examined are either attracted or repelled by a powerful electromagnet. The bodies which are attracted are called magnetic or *paramagnetic*, and those which are repelled are *diamagnetic* bodies. Among the metals, iron, nickel, cobalt, manganese, platinum, cerium, osmium, and palladium are paramagnetic ; while bismuth, antimony, zinc, tin, mercury, lead, silver, copper, gold, and arsenic are diamagnetic, bismuth being the most so and arsenic the least. The three metals iron, nickel, and cobalt exhibit the magnetic property in so marked a degree as compared with other paramagnetic substances that they are generally classed by themselves and called *ferromagnetic* (701). Diamagnetic effects were first observed by Faraday in a particular kind of glass called *Faraday's heavy glass* ; they can be exhibited only by means of very powerful magnets. In experimenting on the diamagnetic effects exhibited by solids, liquids, and gases, pole-pieces of soft iron, S and Q (figs. 1016-1018), of different shapes, are screwed on the magnets.

i. *Diamagnetism of solids.* A small rectangular bar, suspended between the poles of an electromagnet, sets *equatorially*, or at right angles to the lines of force, if it is a diamagnetic substance, such as bismuth, antimony, or copper ; but *axially*, or in the direction of the lines of force, if it is a magnetic substance, such as iron, nickel or cobalt. Besides the substances enumerated above, the following are diamagnetic : rock crystal, alum, glass, phosphorus, iodine, sulphur, sugar, bread ; and the following are magnetic : many kinds of paper and sealing-wax, flint, spar, graphite, charcoal, &c.

ii. *Diamagnetism of liquids.* To experiment with liquids, very thin glass tubes filled with the substance are suspended between the poles instead of the cube *m* in the figure 1017. If the liquids are magnetic, such as solutions of iron or cobalt, the tubes set *axially* ; if diamagnetic, like water, blood, milk, alcohol, ether, oil of turpentine, and most saline solutions, the tubes set

equatorially. The attraction or repulsion of a magnetic substance is affected by the magnetic quality of the medium which surrounds it. For example, a thin glass bulb containing a solution of ferric chloride is attracted when suspended in a vessel containing a weaker solution, and repelled if the vessel contains a stronger solution of ferric chloride. Thus a paramagnetic substance may *appear* to be repelled by a magnet, just as a balloon filled with hydrogen appears to be repelled by the earth, the explanation in each case being that the medium displaced is more powerfully attracted than the body which displaces it.

A diamagnetic substance surrounded by a magnetic or neutral substance sets equatorially. According to its composition glass is sometimes magnetic and sometimes diamagnetic, and as glass tubes are used for containing the

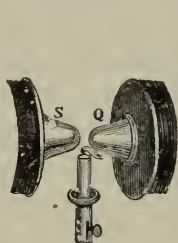

Fig. 1016

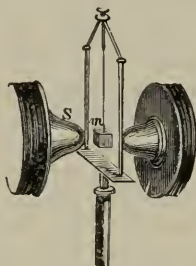

Fig. 1017

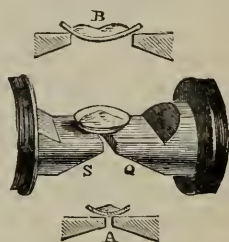

Fig. 1018

liquids in these investigations, its deportment must first be determined, and then taken into account in the experiment.

The behaviour of liquids in a magnetic field may also be observed by Plücker's method. A solution of a para- or diamagnetic liquid is placed on a watch-glass between the two poles, S and Q, of a powerful electro-magnet. When the current passes, the form of the surface is altered as represented in fig. 1018; this continues as long as the current passes, and is produced to different extents with all magnetic liquids. The changes in the aspects of the liquids are, however, so small as to require careful scrutiny to detect their existence. A method of magnifying these changes so as to render them visible to large audiences was devised by Professor Barrett. A source of light is placed above the watch-glass containing a drop of the solution to be tried. Below the watch-glass, and between the legs of the magnet, is placed a mirror at an angle of 45° . By this means the beam of light passing through the watch-glass is reflected at right angles on to a screen, where an image of the drop is focused by a lens. If now a drop of diamagnetic liquid, such as water, or, better, sulphuric acid, be placed on the watch-glass, as soon as the current passes, the drop retreats from the two poles, and gathers itself up into a little heap, as at A (fig. 1018). So doing, it forms a double convex lens, by which the light is brought to a short focus below the drop, an effect instantly seen on the screen. When the current is interrupted the drop falls, and the light returns to its former appearance. A paramagnetic liquid, such as a solution of ferric chloride, has exactly the opposite effect. The drop becomes flattened, and instead of assuming a plano-convex shape, it becomes nearly concavo-convex, as at B. The light

is dispersed, and the effect shows itself on the screen. Instead of a mirror and lens, a sheet of white paper may be placed in an inclined position under the watch-glass; the effects are somewhat varied, but equally pronounced.

iii. *Diamagnetism of gases.* Bancalari observed that the flame of a candle placed between the two poles in Faraday's apparatus was strongly repelled (fig. 1016). All flames present the same phenomenon to different extents, resinous flames or smoke being most powerfully affected.

The magnetic deportment of gases may be exhibited for lecture purposes by inflating soap bubbles with them between the poles of the electromagnet, and projecting on them either the lime or the electric light.

Faraday experimented on the magnetic nature of gases. He allowed gas mixed with a small quantity of a visible gas or vapour, so as to render it perceptible, to ascend between the two poles of a magnet, and observed their deflections from the vertical line in the axial or equatorial direction; in this way he found that oxygen was least, nitrogen more, and hydrogen most diamagnetic. With iodine vapour, produced by placing a little iodine on a hot plate between the two poles, the repulsion is strongly marked. Becquerel found that oxygen is the most strongly paramagnetic of all gases, and that a cubic yard of this gas condensed would act on a magnetic needle like 5.5 grains of iron. This magnetism of gases may be shown by suspending a glass globe to the pan of a balance, above the pole of a powerful magnet; this globe, after being exhausted, is exactly counterpoised, and having been filled with a given gas, the weight is ascertained which is required to detach it. With oxygen the attraction is appreciable, and is five times as much as with air under the same pressure. Faraday found that oxygen, although paramagnetic under ordinary circumstances, became diamagnetic when the temperature was much raised.

Liquid oxygen is highly paramagnetic. Dewar found that when some of this contained in an open glass vessel was brought near the pole of a powerful electromagnet, it flew towards it and remained adherent until all was evaporated.

In the crystallised bodies which do not belong to the regular system, the directions in which the magnetism or diamagnetism of a body is most easily excited are generally related to the crystallographic axis of the substance. The optic axis of the uniaxial crystals sets either axially or equatorially when a crystal is suspended between the poles of an electromagnet. Faraday assumed from this the existence of a *magneto-crystalline* force, but it appears probable from Knoblauch's researches that the action arises from an unequal density in different directions, inasmuch as unequal pressure in different directions produces the same result.

According to Plücker, for a given magnetising force, the specific magnetisms developed in equal weights of the undermentioned substances are represented by the following numbers, those bodies with the minus signs prefixed being diamagnetic:—

Iron	1,000,000	Nickel oxide	287
Cobalt	1,009,000	Phosphorus	-13.1
Nickel	465,800	Water	-25
Iron oxide	759	Bismuth	-23.6

If a sphere of iron is placed in a uniform magnetic field, lines of force are drawn into the substance of the sphere so that the number of lines through it is greater than the number that previously passed through the space

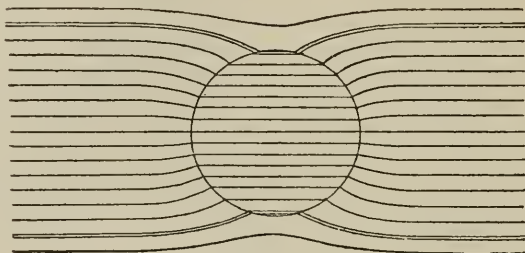

Fig. 1019

which it occupies (fig. 1019). Its magnetic susceptibility (722) is positive, and its magnetic permeability greater than unity. If, however, the substance of the sphere is diamagnetic—for instance, a ball of bismuth—the lines of force in the field are apparently repelled, so that fewer lines pass through it than would have been the case had it been a neutral substance (fig. 1020). Its

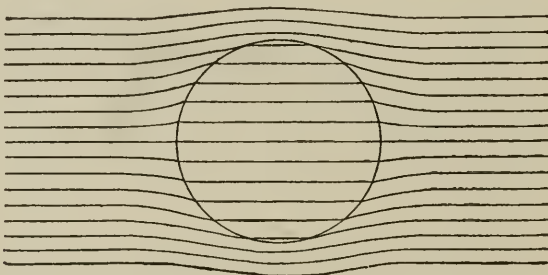

Fig. 1020

susceptibility is negative and its permeability less than unity. A rod of iron places itself axially in a magnetic field, because in that position the number of lines of force or induction passing through it is a maximum; a rod of bismuth similarly places itself equatorially to render the number of lines of induction a minimum. Paramagnetic substances move into the strongest parts of a variable field, diamagnetic substances into the weakest.

CHAPTER XIV

CONNECTION BETWEEN ELECTRICITY AND LIGHT

996. **Optical effects of powerful magnets.**—Faraday discovered, in 1845, that a powerful magnetic field exercises an action on the propagation of light in substances exposed to its action; thus if a polarised ray traverses them in the direction of the lines of force, the plane of polarisation is rotated either to the right or to the left according to the direction of the magnetisation.

Fig. 1021 represents Faraday's apparatus, as constructed by Ruhmkorff. It consists of two powerful electromagnets, M and N, fixed on two iron

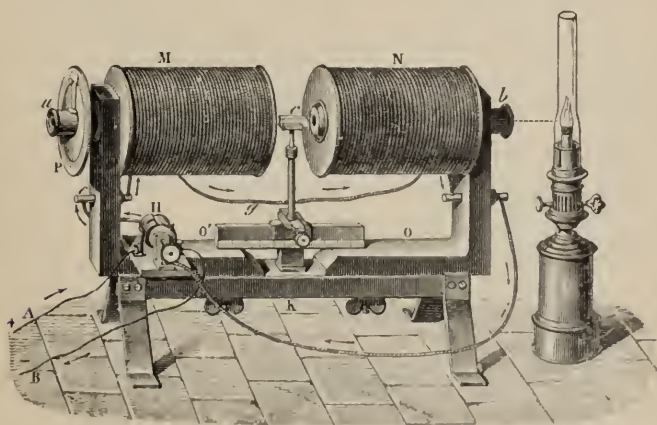

Fig. 1021

supports, O O', which can be moved on an iron base, K. The current from a battery of 20 volts passes by the wire A to the commutator, H, the coil M, and then to the coil N, by the wire *g*, descends in the wire *i*, passes again to the commutator, and emerges at B. The two cylinders of soft iron, which are in the axis of the coils, are perforated by cylindrical holes to allow the light to pass. At *b* and *a* there are two Nicol prisms, *b* serving as polariser and *a* as analyser. By means of a limb this latter can be rotated about a horizontal axis, the angle being read off on a graduated circle, P.

The two prisms being then placed so that their principal sections are perpendicular to each other, the prism *a* completely extinguishes the light

transmitted through the prism *b*. If at *c*, on the axis of the two coils, a slab is placed with parallel faces, of heavy or flint glass, monochromatic light is still extinguished so long as the current does not pass; but when the connections are made, the light reappears, and in order to extinguish it the analyser must be turned through an angle which can be read off on the limb, and which measures the rotation. By reversing the direction of the current the rotation is reversed. If the source of light is not monochromatic, and if the analyser is turned to left or right, according to the direction of the current, the light passes through the different tints of the spectrum, as is the case with plates of quartz cut perpendicularly to the axis (690). Becquerel showed that a large number of other substances besides heavy glass rotate the plane of polarisation under the influence of powerful magnets. The direction of the rotation for most transparent sub-

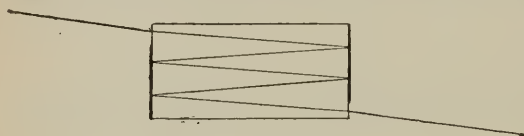

Fig. 1022

stances is the same as that of the current which produces the given magnetic field, and is independent of the direction in which the rays of light pass. Hence if the ray is reflected on itself and traverses the substance a second time in the opposite direction, the rotation is doubled. By thus increasing the path of the ray by successive reflections (fig. 1022), the rotation may be increased in the same proportion.

The rotation of the plane of polarisation between two points is proportional to the distance between the two points and to the intensity of the magnetic field. This is known as *Verdet's law*.

The angle, expressed in circular measure, through which the plane of polarisation is rotated, when unit magnetic field acts upon a plate 1 cm. thick of a given material, is called *Verdet's constant* for that material. For different rays it is *nearly* as the inverse square of the wave-length. For the ray D and at 0° it is $0.040'$ for bisulphide of carbon and $0.013'$ for water. It diminishes with rise of temperature.

By means of Faraday's apparatus it has been found that thin layers of iron, cobalt, and nickel, so fine as to be transparent, exert a powerful rotation of the plane of polarisation for transmitted light. The rotation for the central rays of the spectrum in iron is 32,000 times that in glass of the same thickness. In all diamagnetic substances the rotation is in the direction of the magnetising current; in paramagnetic substances it is in the opposite direction.

997. **Kerr's electro-optical experiments.**—Dr. Kerr discovered a remarkable relationship between electricity and light. He found that when certain dielectrics are subjected to electric strain, they become doubly refracting (673). The general arrangement of the experiments is as follows:—A cell, P (fig. 1023), is suitably constructed of stout glass plates, in which is placed the liquid under examination; its dimensions are 4 inches in length by 1 inch in width, and about $\frac{1}{8}$ of an inch in thickness. Two copper plates placed horizontally, and kept at a distance of about $\frac{1}{2}$ of an inch, can be

connected with the electrodes of a Holtz machine (fig. 744), or, what is more convenient, with the opposite coatings of a Leyden jar, which in turn is charged by such a machine. B is the mirror of a heliostat, by which a beam of light may be sent in the required direction. M and N are two Nicol prisms (674); C is a compensator, while D is a condensing lens.

Of the two Nicol prisms, M serves as polariser, and N as analyser (670); at the outset they are arranged so that their principal sections are at

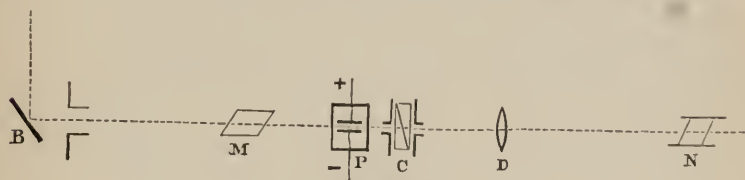

Fig. 1023

right angles to each other, and make an angle of 45° with the vertical. Thus the light polarised by the prism M is extinguished by the analyser N, so that the field between them is quite dark, and remains so even when the cell is filled with liquid; the cell is so arranged that the observer looks through the slit of dielectric which is between the conductors in the cell.

If now the plates are oppositely charged, the field at once becomes clear. Of all dielectrics hitherto examined, carbon bisulphide is that which best exhibits the phenomenon. A fraction of a turn of a Holtz machine is at once sufficient to produce light in the field, which disappears immediately the plates are discharged. As the machine is worked and the potential rises, the light between the conductors gradually increases in brightness until a pure and brilliant white is obtained; with further increase of potential a fine progression of chromatic effects is obtained; the luminous band between the conductors changes first from white to a straw colour, which deepens gradually to a rich yellow; it then passes through orange to a deep brown, next to a pure and dense red, through purple and violet to a rich and full blue, and then to green. All the colours are beautifully dense and pure, and as fine as anything seen in experiments with crystals in the polariscope. The phenomenon generally ceases at the green of the second order with a discharge of electric sparks. The action of carbon bisulphide under electric strain is similar to that of rapidly cooled glass or glass stretched in a direction parallel to the lines of force; it is an action of the same kind as that of a uniaxial crystal (677); in this respect carbon bisulphide occupies a place among dielectrics similar to that of Iceland spar among crystals.

In order to measure the effect produced, a compensator, C, is placed behind the cell; the plates are connected with Lord Kelvin's quadrant electrometer in such a manner that the potential can be directly measured, and then compared simultaneously with the difference of the path of the extraordinary and ordinary ray in the dielectric. Kerr arrived thus at the law: 'The strength of the electro-optical action of a given dielectric, that

is, the difference in the path of the ordinary and extraordinary rays, for unit thickness of the dielectric, varies directly as the square of the resultant electrical force.' Kerr also found that when a pencil of plane polarised light is reflected from the polished surface of either pole of an electromagnet of iron, it undergoes a rotation in the direction contrary to that of the magnetising current. This result is also obtained when it is reflected from the sides of the electromagnet when the magnet is excited.

998. **Zeeman effect.**—Another connection between light and magnetism was discovered by Zeeman in 1897, who found that the spectrum lines of an incandescent vapour are modified when the vapour is subjected to a powerful magnetic field. Suppose the spark giving the incandescent vapour to have the position *c* in fig. 1021, and to be examined in a direction at right angles to the lines of force. It is found that each spectrum line is tripled, and the separation between the constituents of a triplet is proportional to the strength of the magnetic field. Using a polariscope in combination with the spectroscope, it is found that the outer lines are polarised in a plane parallel to the lines of force, and the central line in a plane perpendicular to the lines. If the radiant vapour is viewed in a direction parallel to the magnetic field, which can be done with the arrangement illustrated in fig. 1021, the central line of the triplet vanishes, while the outer ones are circularly polarised—the shorter waves (those nearer the violet end of the spectrum) in the direction of the magnetising current, and the longer waves in the opposite sense.

Further investigation has shown that the phenomena are much more complicated than was at first supposed; different spectrum lines are found to behave in different ways in the magnetic field, some appearing as quartets, while others are resolved into sextets or more complicated forms.

999. **Influence of light on conductivity. Photophone.**—The metalloid selenium has under ordinary conditions a high resistance, but if a specimen of this substance is raised to the melting temperature and slowly cooled, it becomes a moderately good conductor. Its resistance in this state is changed, to a marked extent, when light falls upon it. This was shown by the following experiment:—A thin strip of selenium, about 38 mm. long by 13 mm. broad, was provided at the ends with conducting wires and placed in a box with a draw-lid. The selenium, having been carefully balanced in a Wheatstone's bridge, was exposed to diffused light by withdrawing the lid, when the resistance at once fell in the ratio of 11 to 9. On exposure to the various spectrum colours, after having been in the dark, it was found to be most affected by the red, but the maximum action was just outside the red, where the resistance fell in the ratio of 3 to 2. Momentary exposure to the light of a gas-lamp, or even to that of a candle, caused a diminution of resistance. Exposure to full sunlight diminished the resistance by one-half. The effect produced on exposure to light is immediate, while recurrence to the normal state takes place more slowly. A vessel of hot water placed near the strip produced no effect, and hence the phenomenon cannot be due to heat, but there appear to be certain rays which have the power of producing a molecular change in the selenium by which its conductivity is increased.

If the two electrodes of a Ruhmkorff coil are connected with a Geissler tube, suitably exhausted, so that a discharge just does not pass when the

apparatus is in the dark, it passes at once when the tube is exposed to ultra-violet rays.

It has also been noticed that the length of a spark between two discharging spheres is modified when ultra-violet light—for example, that radiated by another spark in the neighbourhood—falls upon the spheres.

On the property which selenium has of changing its resistance, due to the incidence of light upon it, is based the action of an apparatus invented by Mr. A. Graham Bell, and called by him a *photophone*, by which articulate speech can be transmitted to a considerable distance by the simple agency of a beam of light. Its performance depends not only upon the action of light on crystallised selenium, but also on the fact that a thin plate of glass bulges—becomes alternately convex and concave—when sound waves fall upon it.

A plate of microscope glass, silvered in front, is fitted into a mouthpiece like that of a telephone, the silvered face being outside. This is the transmitter. A powerful beam of solar, or electric, light is directed by a large mirror on the transmitter, and, after reflection, is rendered parallel by means of a suitable lens. It then falls upon a parabolic mirror in a direction parallel to the axes, and accordingly converges after reflection to the focus, where a selenium cell is fixed. The latter is constructed as follows:—Two fine copper wires are wound side by side, and as close together as possible, without touching, on a small strip of mica, there being 20 or 30 turns. The free ends of the wire are connected to a circuit containing battery and telephone.

The spaces between the successive turns are now filled with melted selenium, which is carefully annealed and then rendered sensitive to the action of light.

When the parallel beam of light is concentrated on the selenium cell, the latter will have a definite resistance and no sound will be heard in the telephone. But if the transmitter is spoken into, the microscope glass vibrates, changes its curvature, and so causes the beam, which falls on the parabolic mirror, to be alternately diverging and converging. The result is that the quantity of light falling on the selenium cell, and hence its resistance, changes in correspondence with the words spoken into the transmitter.

1000. **Absolute electric units. Dimensions.**—Assuming the centimetre, gramme, and second as units respectively of length, mass, and time, it has been shown (63) how the units of force, work, &c., may be derived from them. We may now proceed to the further derivation of electric units and determine their dimensions, that is, their relation to the fundamental units; and there are two ways in which this may be done. We may start with the law of repulsion between two similar charges of electricity, and build up a system on this basis; this system is called the *electrostatic system*. Or we may take as our starting-point the repulsion between two magnetic poles, the system so derived being called the *electro-magnetic system*. Each of these systems is *absolute*, in the sense that in both the various units are derived in the simplest possible manner from the centimetre, gramme, and second. The electrostatic system is, perhaps, the simpler of the two, but that based on magnetic action is more convenient, and best lends itself to

the practical determination of the more important standards, such as those of E.M.F. and resistance.

We shall distinguish the electrostatic units by small, and the electromagnetic units by the corresponding capital letters, a square bracket indicating that the dimensions of the particular quantity are referred to.

ELECTROSTATIC SYSTEM.

Quantity of electricity, q .—Coulomb's law states that the repulsion between two equal charges of q units, separated by a distance r , in air, is $F = \frac{q^2}{r^2}$ (753). If the charges are placed, not in air, but in a medium whose specific inductive capacity is κ , the force in action between them is given by $F = \frac{q^2}{\kappa r^2}$. The dimensions of κ are not known, but as we have no right to assume that the specific inductive capacity of a substance is independent of length, mass, and time, we must retain the symbol κ in the equations to represent its unknown dimensions.

Hence $q = F^{\frac{1}{2}} \kappa^{\frac{1}{2}} r$, and since $[F] = MLT^{-2}$ (63)

$$[q] = M^{\frac{1}{2}} L^{\frac{1}{2}} T^{-1} \kappa^{\frac{1}{2}} L = M^{\frac{1}{2}} L^{\frac{3}{2}} T^{-1} \kappa^{\frac{1}{2}}.$$

Potential, e .—Since W (work) = eq , and $[W] = ML^2T^{-2}$

$$[e] = ML^2T^{-2} \div M^{\frac{1}{2}} L^{\frac{3}{2}} T^{-1} \kappa^{\frac{1}{2}} = M^{\frac{1}{2}} L^{\frac{1}{2}} T^{-1} \kappa^{-\frac{1}{2}}.$$

Capacity, c .—Since quantity = capacity \times difference of potential (760) $c = \frac{q}{e}$,

$$\therefore [c] = M^{\frac{1}{2}} L^{\frac{3}{2}} T^{-1} \kappa^{\frac{1}{2}} \div M^{\frac{1}{2}} L^{\frac{1}{2}} T^{-1} \kappa^{-\frac{1}{2}} = L\kappa.$$

Thus the capacity of a conductor depends on length and specific inductive capacity only. It has been shown (760) that, in air, the capacity of a sphere is equal to its radius.

Current, i .—The strength of a current is the quantity of electricity passing per unit time, or $i = \frac{q}{t}$

$$\therefore [i] = M^{\frac{1}{2}} L^{\frac{3}{2}} T^{-2} \kappa^{\frac{1}{2}}.$$

Resistance, r .—By Ohm's law, $r = \frac{e}{i}$,

$$\therefore [r] = M^{\frac{1}{2}} L^{\frac{1}{2}} T^{-1} \kappa^{-\frac{1}{2}} \div M^{\frac{1}{2}} L^{\frac{3}{2}} T^{-2} \kappa^{\frac{1}{2}} = L^{-1} T \kappa^{-1}.$$

ELECTROMAGNETIC SYSTEM

In this system the action between two magnetic poles is the starting-point. By Coulomb's law (719) $F = \frac{m^2}{r^2}$, if the poles, each of strength m , are separated by a distance, r , in air. If, however, the medium has a magnetic

permeability μ , the force is $\frac{m^2}{\mu r^2}$. The symbol μ must be retained, as we do not know the dimensions of magnetic permeability.

Magnetic pole, m.—From the formula $F = m^2/\mu r^2$, we have

$$[m] = M^{\frac{1}{2}} L^{\frac{3}{2}} T^{-1} \mu^{\frac{1}{2}}.$$

Magnetic field, H.—Unit magnetic field is that in which unit pole is acted on by unit force, or $H = \frac{\text{Force}}{m}$,

$$\therefore [H] = MLT^{-2} \div M^{\frac{1}{2}} L^{\frac{3}{2}} T^{-1} \mu^{\frac{1}{2}} = M^{\frac{1}{2}} L^{-\frac{1}{2}} T^{-1} \mu^{-\frac{1}{2}}.$$

Magnetic induction or flux density, B.—Since $B = \mu H$ (721),

$$[B] = M^{\frac{1}{2}} L^{-\frac{1}{2}} T^{-1} \mu^{\frac{1}{2}}.$$

Electric current, I.—If a current of strength, I , flows through a wire of length, r , bent into the form of an arc of a circle of radius r , the force on a pole placed at the centre of the circle is mIr/r^2 , or, $F = mI/r$. Hence the dimensions of a current are given by

$$\begin{aligned} [I] &= MLT^{-2}L \div M^{\frac{1}{2}} L^{\frac{3}{2}} T^{-1} \mu^{\frac{1}{2}} \\ &= M^{\frac{1}{2}} L^{\frac{1}{2}} T^{-1} \mu^{-\frac{1}{2}}. \end{aligned}$$

Quantity of electricity, Q.—Since $Q = It$,

$$[Q] = M^{\frac{1}{2}} L^{\frac{1}{2}} \mu^{-\frac{1}{2}}.$$

Electromotive force. Difference of potential, E.—Since work, $W = EQ$,

$$[E] = ML^2T^{-2} \div M^{\frac{1}{2}} L^{\frac{1}{2}} \mu^{-\frac{1}{2}} = M^{\frac{1}{2}} L^{\frac{3}{2}} T^{-2} \mu^{\frac{1}{2}}.$$

Resistance, R.—By Ohm's law, $R = \frac{E}{I}$,

$$\therefore [R] = M^{\frac{1}{2}} L^{\frac{3}{2}} T^{-2} \mu^{\frac{1}{2}} \div M^{\frac{1}{2}} L^{\frac{1}{2}} T^{-1} \mu^{-\frac{1}{2}} = LT^{-1} \mu.$$

Capacity, C.—Since $Q = EC$,

$$[C] = M^{\frac{1}{2}} L^{\frac{1}{2}} \mu^{-\frac{1}{2}} \div M^{\frac{1}{2}} L^{\frac{3}{2}} T^{-2} \mu^{\frac{1}{2}} = L^{-1} T^2 \mu^{-1}.$$

In article 737 the dimensions of magnetic pole, magnetic field, and magnetic flux were given on the assumption that the force F , between two poles = $\frac{mm'}{r^2}$. The reader will have no difficulty in modifying them, by taking $F = \frac{mm'}{\mu r^2}$, so as to avoid the assumption that the magnetic permeability of the medium is equal to unity.

1001. **Relation of electrostatic to electromagnetic units.**—Since the dimensions of any physical quantity must be the same whatever system of units is employed in specifying it, it follows that the dimensions of q, e, ϵ , &c., are the same respectively as those of Q, E, C , &c. Now, as we have seen, $[q] = M^{\frac{1}{2}} L^{\frac{3}{2}} T^{-1} \kappa^{\frac{1}{2}}$, and $[Q] = M^{\frac{1}{2}} L^{\frac{1}{2}} \mu^{-\frac{1}{2}}$, and therefore

$$M^{\frac{1}{2}} L^{\frac{3}{2}} T^{-1} \kappa^{\frac{1}{2}} = M^{\frac{1}{2}} L^{\frac{1}{2}} \mu^{-\frac{1}{2}},$$

$$\therefore LT^{-1} = \kappa^{-\frac{1}{2}} \mu^{-\frac{1}{2}}.$$

That is, $\frac{1}{\sqrt{\mu\kappa}}$ is of the nature of a velocity; call it v . The same result is arrived at if we equate the dimensions, on the two systems, of any of the other magnitudes. Thus, although we know nothing as to the dimensions of either κ or μ , we see that the reciprocal of the square root of their product is a velocity. This velocity can be determined by measuring a given quantity of electricity, or a given difference of potential, or the capacity of a given condenser, both electrostatically and electromagnetically. For example, if P_s is the numerical value of a certain definite quantity of electricity measured on the electrostatic system, and P_m the numerical value of the same quantity measured on the electromagnetic system, we must have

$$P_s \{(\text{gr.})^{\frac{1}{2}} (\text{cm.})^{\frac{3}{2}} (\text{sec.})^{-1} \kappa^{\frac{1}{2}}\} = P_m \{(\text{gr.})^{\frac{1}{2}} (\text{cm.})^{\frac{1}{2}} \mu^{-\frac{1}{2}}\}$$

$$\text{or, } \frac{P_s}{P_m} \cdot \left(\frac{\text{cm.}}{\text{sec.}}\right) = \mu^{-\frac{1}{2}} \kappa^{-\frac{1}{2}} = v.$$

Thus the ratio of P_s to P_m (which ratio has the dimensions of a velocity) is equal to v . Let a condenser be constructed of brass plates separated by air; its capacity is $\frac{A}{4\pi d}$ (799), and if it is charged and the difference of potential, V , between its coatings is measured by an absolute electrometer (797), its charge, expressed in electrostatic measure, is $\frac{AV}{4\pi d} = P_s$. If the condenser is then discharged through a ballistic galvanometer (843) of known constants, the charge (electromagnetic) $= P_m = \frac{HT}{\pi G} \sin \frac{\theta}{2}$. The ratio P_s/P_m is found to be about $3 \times 10^{10} = v$, from which it follows that the unit in terms of which P_s is measured is $\frac{1}{3 \times 10^{10}}$ that in which P_m is measured; or that the electromagnetic unit of quantity is 3×10^{10} times the electrostatic unit. Similarly, it has been found that the electrostatic unit of electromotive force or potential is 3×10^{10} electromagnetic units, &c. The relations between the units may be formulated as follows:

1	electromagnetic unit of quantity	= v	electrostatic units
I	" " current	= v	" "
I	" " capacity	= v^2	" "
v	" units of E.M.F.	= 1	" unit
v^2	" " resistance	= 1	" "

The first determination of v was made in 1856 by Weber and Kohlrausch, who measured a quantity of electricity, and found $v = 3.107 \times 10^{10}$. Since that time many determinations of v have been made, amongst others by Lord Kelvin, Clerk Maxwell, Ayrton and Perry, Rowland, and J. J. Thomson. The mean value of the various results obtained is very nearly 3×10^{10} . This number agrees very closely with that which has been experimentally found for the velocity of light—186,400 miles per second (518).

1002. **Electromagnetic theory of light.**—When two conducting plates separated by a dielectric, such as the coatings of a Leyden jar, are connected to the poles of a battery, the plates become oppositely charged. The positive and negative charges strive to unite, and would do so were the medium

between them a conductor. Although no current in the ordinary sense passes, we have seen that the dielectric is profoundly modified by the presence of the charges on the plates. According to Faraday it is polarised (766), and Dr. Kerr's experiments (797) showed that it is strained, as a solid is strained by the application of mechanical stress. The experiment of the dissected Leyden jar (787) showed that the electrification of the charged jar resided in the glass, and that the metal coatings merely served the purpose of distributing the charge over the surface of the glass. Using the phraseology of Clerk Maxwell, we say that when connection of the plates with the battery is made, a *displacement* of electricity takes place in the dielectric, or that there is a *displacement current* through the dielectric, positive electricity tending to move in the direction of the electromotive force, the result being that if the positive plate has a charge Q , an equal quantity, Q , passes through each section of the dielectric drawn parallel to the plate. This displacement of electricity from point to point is resisted by the *electric elasticity* of the dielectric, so that for a given applied electromotive force the displacement (and therefore the charge Q) is least in the case of that dielectric whose *electric elasticity* is greatest, just as, for a given applied mechanical pressure, the deformation of an elastic solid is inversely proportional to the elasticity of the solid. But we know that when a condenser is charged, the charge for a given applied E.M.F. is proportional to the specific inductive capacity of the dielectric (783). Hence the electric elasticity of a medium is inversely proportional to its specific inductive capacity; its reciprocal is sometimes called the *pliability* of the medium, so that $\text{pliability} = 1/\kappa$, when κ is the specific inductive capacity.

If the plates are alternately charged in opposite directions, the electric displacement alternates, and as it is always resisted by the electric elasticity of the dielectric, it follows that if the alternations follow each other with sufficient rapidity, they will give rise to waves in the surrounding medium, just as the to-and-fro motions of air particles give rise to sound waves in air. Now a disturbance, when produced at any point in an elastic medium, spreads with a velocity $= \sqrt{\frac{e}{d}}$ (231), where e is the elasticity and d the density of the medium. If we imagine a medium whose elasticity is $1/\kappa$, κ being its dielectric constant, and whose density is μ , the magnetic permeability of the medium, the velocity of wave motion through it will be $\sqrt{\frac{1}{\mu\kappa}}$, which is equal to v , the velocity of light.

Clerk Maxwell, discarding the idea of action at a distance, adopted the views of Faraday as to the part played by the media surrounding conductors in electric phenomena; these views he represented in mathematical forms, and so rendered them capable of theoretical development. Maxwell's theory led him to the conclusion that electric and magnetic forces are propagated from one place to another by a medium which occupies all space, with a velocity $1/\sqrt{\kappa\mu}$, where κ is the specific inductive capacity, and μ the magnetic permeability of the medium. Now this is the velocity of light through what we call the luminiferous ether, and as it seems unnecessary to fill all space with two different ethers through which luminous and electric disturbances

respectively travel with equal velocities, we are led to the conclusion that the same medium transmits both, and further, that luminous and electric disturbances are the same in kind ; in other words, that light is an electromagnetic phenomenon. This is Maxwell's electromagnetic theory of light.

One consequence of the theory is that the specific inductive capacity of a medium should be equal to the square of its refractive index. For consider two media, say air and glass : let κ_1 and μ_1 be the sp. ind. cap. and permeability of air, and V_1 the velocity of propagation through it, and let κ_2, μ_2, V_2 have the same meanings in reference to glass ; also let n be the refractive index of glass ; that is, the ratio of the velocity of light in air to the velocity in glass. Then, $n = \frac{V_1}{V_2} = \sqrt{\frac{\mu_2 \kappa_1}{\kappa_2 \mu_1}}$. But the magnetic permeability of air and glass are practically the same, and if we call the sp. ind. capacity of air unity, $\kappa_2 = \kappa$ = the specific inductive capacity of glass with air taken as the standard, and then $n = \sqrt{\kappa}$ or $\kappa = n^2$. This is known as *Maxwell's law*.

Since the refractive index of a substance varies with the wave-length of the radiation, it is clear that if we wish to test Maxwell's law by experimentally determining κ and n , the experiments ought to be made under like conditions with regard to wave-length, and unless this is done we cannot expect very close agreement. The following substances, for which κ and n were determined in the ordinary way at the temperature of the atmosphere, obey the law very fairly :—

Substance	κ	n^2
Paraffin	2'29	2'02
Petroleum oil	2'07	2'075
Turpentine	2'23	2'128
Benzine	2'38	2'26
Carbon bisulphide	2'67	2'67
Sulphur	4'73	4'89
Resin	2'55	2'37

Exceptions are much more numerous than accordances, but it has been shown by Fleming and Dewar, in the case of many substances, that the specific inductive capacity varies enormously with temperature, and that if it is determined at a very low temperature, the agreement between κ and n^2 is much closer than at ordinary temperatures. The following are examples, taken from Fleming's Cantor lectures :—

Substance	κ at 15° C.	κ at -185° C.	n^2
Water	30	2'4-2'9	1'78 (D line)
Ethyl alcohol	25'8	3'11	1'83
Amyl „	16	2'14	1'95
Ethylic ether	4'25	2'31	1'81
Olive oil	3'16	2'18	2'13

In the case of water it has been found that n , measured electrically for waves about 6 metres long, is 8.9, hence $n^2 = 79.2$, and is therefore equal to κ at ordinary temperatures.

Faraday was unable to detect any difference in the dielectric constants of various gases. Boltzmann has shown, however, that there are differences among them, and that for them there is a very close agreement between $\sqrt{\kappa}$ and n , as is seen from the following table:—

—	κ	$\sqrt{\kappa}$	n
Vacuum	1.00000	1.000000	1.000000
Air	1.00059	1.000295	1.000294
Carbon dioxide	1.00095	1.000473	1.000449
Hydrogen	1.00026	1.000132	1.000128
Ethylene	1.00131	1.000656	1.000678

1003. **Hertz's experiments.**—The theoretical previsions of what is known as the 'Faraday-Maxwell' theory received a striking confirmation in a most remarkable and beautiful series of experiments by the late Professor Hertz, of which we can only give an outline of some of the principal results.

In order to demonstrate that light is essentially an electromagnetic phenomenon, it would be necessary to produce, with a vibratory motion of purely electromagnetic origin, the same class of phenomena as can be produced with ordinary light, such, more especially, as interference and refraction.

Hertz devised an apparatus which he calls a *vibrator* or *oscillator* or *radiator* for obtaining by continuous but very rapid electric oscillations true rays of electric energy. Two spheres or plates of metal, A A' (fig. 1024), are provided with straight metal rods with small knobs at the end, the distance, C, of which can be adjusted. The rods are in connection with the terminals of a Ruhmkorff coil B, which charges the two spheres to different potentials, and a spark passes at C. This spark, by heating the air, forms, as it were, a path for the subsequent oscillations (800), and the vibrator now discharges itself independently, as if it were detached from the coil, forming between the discharges of the Ruhmkorff a series of oscillations of extreme rapidity. Theory shows that the period, t , of the oscillations in ACA' = $2\pi\sqrt{LC}$, where C is the capacity of the two plates or spheres A, A', and L the self-induction of the rod and spark gap connecting them, both expressed in electromagnetic units. In considering the electric oscillations in ACA', we may leave the induction coil out of consideration, regarding it merely as a device for charging A and A' up to a certain difference of potential. If the small knobs at C are a little less than 1 centimetre apart, the difference of potential between A and A' will rise to about 36,000 volts (805) before a spark occurs. When a spark passes electric oscillations are set up in the conductor ACA' (800), each part of it becoming alternately positively and negatively charged, and thus waves are produced in the surrounding

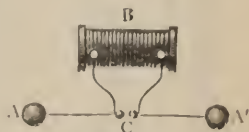

Fig. 1024

space. Hertz succeeded in measuring the length of these waves and also their velocity, which he showed to be the same as that of light, thus confirming Maxwell's theory. In one of Hertz's experiments A and A' were spheres 15 cm. in radius, and the connecting wire was 1 metre long, with a spark gap of 1 centimetre in the middle. The wave-length of the radiated waves was found to be 4.8 metres, which gives, as the period of the oscillation, since $v\lambda = \lambda$, 1.6 hundred-millionths of a second. The oscillations diminish rapidly in amplitude; indeed, after ten or twelve to-and-fro swings they come to an end. Thus the whole series is completed in the one five-millionth part of a second, and for the rest of the interval between one spark and another there is no radiation.

Let us next consider how electric radiation may be detected. If we have a vibrating tuning-fork producing sound waves and we approach to it a body tuned in unison with the fork, the body in question begins to vibrate also; such bodies, as we have seen, are called *resonators* (255). In order to investigate the distribution of electric waves in the region about a vibrator, Hertz used what he called an *electric resonator*. This consists (fig. 1025) of a wire ring, one end terminating in a point and the other in a small knob, which by a micrometric arrangement, not shown in the figure, may be kept at any desired distance. The dimensions of the frame are adjusted—*tuned* as it were—so that its oscillations synchronise with those of the vibrator.

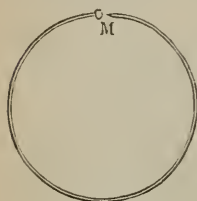

Fig. 1025

If now the resonator is placed with its axis parallel to the axis of the vibrator—positions are found in which a flow of minute sparks passes between the ends of the resonator; their quantity and strength diminish as the distance from the vibrator increases, but are perceptible at even 50 or 60 feet. These waves are transverse to the direction of propagation, as appears from the fact that when in a given position the resonator is giving sparks, it ceases to do so when turned at right angles. When the vibrator works well the whole room is pervaded by electric waves, and by varying the position and distance of the resonator in reference to the vibrator, it is possible to plot out the exact form of the wave motion in the field.

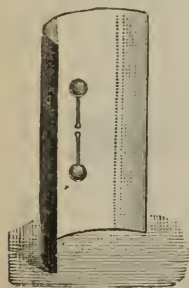

Fig. 1026

These electric waves pass through ordinary conductors, such as a door, or a wall, but are reflected from a conducting surface. If the vibrator is placed at a suitable distance in front of a large sheet of metal, the waves are reflected from the wall, and interfering with incident rays give rise to stationary waves made up of nodes and loops at regular intervals, quite analogous to the corresponding acoustical phenomenon. This may be demonstrated by means of the resonator, which gives no spark if placed at a node, but does so if in a loop. If the metal is a perfect conductor, there is formed a node at the reflecting surface and others at equal distances. This is analogous to the case of a stopped pipe.

If the vibrator is placed in front of a tall cylindrical metal reflector with a parabolic section (fig. 1026), the effects produced are more pronounced,

and can be perceived at a greater distance than before. A mass of electric rays parallel to the focal line is formed, and the experiment of the conjugate mirrors (425) may be repeated. An insulating screen placed between the two mirrors does not stop the action, but a conducting screen does.

The electric rays undergo refraction on passing from one medium to another. This Hertz demonstrated by means of a huge prism of pitch, weighing about half a ton, 5 feet in height, with a refracting angle of 30° , and with a face of over a square yard. When the rays, rendered parallel by the mirror, fell on this, they were deflected towards the base, and by means of the resonator the position of minimum deviation could be obtained, and thus the refractive index was found to be 1.69; the optical refractive index is between 1.5 and 1.6.

By allowing electric rays to fall on a plane reflecting surface, part are absorbed and part reflected, and it is readily shown that the angle of reflection, as with light and heat, is equal to the angle of incidence (522).

If the electric rays concentrated by a mirror fall on a grating formed of parallel copper wires, it is found that when the grating is in the direction of the rays—that is, when the wires are parallel to the focal line of the mirror—they are stopped, but are transmitted when the wires are turned at right angles to the direction. This is a phenomenon of polarisation; the grating acts in regard to the rays like a tourmaline in respect of plane polarised light (672). In another experiment Hertz reproduced the phenomena of diffraction (661).

Hertz's experiments have been reproduced by many observers, and with other resonators and modifications in the way of experimenting. Dragoumis found that Geissler's tubes were well fitted for this purpose. Lecher's method of investigation is convenient. The vibrator is formed of two metal plates,

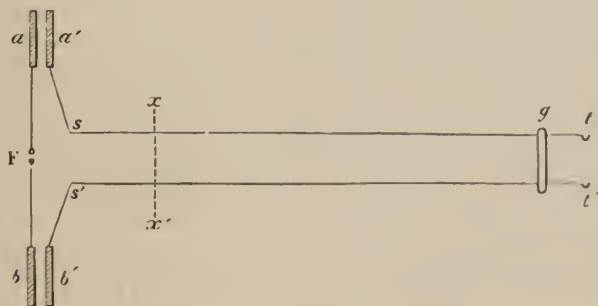

Fig. 1027

$a b$ (fig. 1027), connected with the terminals of a Ruhmkorff coil as in fig. 1023, opposite which are two similar ones, $a'b'$; from these pass wires, $s s'$, 40 or 50 feet in length and about 6 inches apart, parallel from s to t , which are tightly stretched by means of strings.

In this arrangement a and b are the plates of two condensers which discharge with oscillations when the induction coil is set in action. The

potentials of the plates a' and b' are therefore raised and lowered with great frequency; hence the wires connected to them are subjected to rapidly varying electromotive force, and if they are properly adjusted as to length and distance apart, stationary waves are produced in them due to high frequency oscillating currents. At the free ends of the wire will be loops—that is, there will be maximum changes of potential there, but no currents. If a Geissler tube g , with or without electrodes, is placed across the ends of the wires, it becomes luminous; and if a metal wire, xx' , is placed across the wires the luminosity may cease, but by moving the cross wire backwards or forwards, positions are found for which the luminosity reappears. This happens when the two separate circuits, $a'sx's'b$, xgx' , are in resonance with each other. If a portion of each of the wires is cut off the resonance is disturbed, the tube is dark, and to restore the luminosity the bridge xx' must be moved nearer to F ; the amount of the displacement is half the length of the pieces thus cut off.

If a sheet of tinfoil is attached to each end, the capacity is increased, the period of the vibration is increased, the wave-length is greater, and to keep the tubes luminous the cross wire must be moved nearer the ends $t't'$. This leads to a method of determining the electric wave-length. In certain experiments with a period of vibration of the one ten-millionth of a second, the distance of two consecutive nodes, or half a wave-length, was found to be 14 m., so that from the formula (226) this gives for the velocity of electric waves 280,000 kilometres per second—that is, approximately the same as that of light (518).

The velocity is the same whatever be the nature of the wires used, from which it follows that the transmission is effected by the medium between the wires and not by the wire itself.

The positions of the nodes on either of the wires st , $s't'$ may be found by encircling the wire by an insulated coil of fine platinum wire which is included in one arm of a Wheatstone's bridge (923). The resistance of the wire is increased when its temperature is raised. When the coil is situated at a current-node on the wire its resistance is not altered, but it increases and rises to a maximum as the coil is shifted to a point half-way between two nodes. At the two sides of a node the oscillatory currents are always in opposite directions, and so there is practically no current and no development of heat; at a loop the currents have their maximum intensity, and the wire is heated to the greatest extent. Thus the platinum-wire coil acts as a bolometer (932). A thermo-electric junction of iron and nickel is frequently used instead of the platinum-wire coil.

The circular wire resonator of Hertz presents many difficulties in its use. The sparks are always small and cannot generally be seen except in a dark room. A much more sensitive detector or receiver is that which was called by Lodge a *coherer*, and is based on an experiment made by Branly, in which a circuit was formed including a Daniell cell, a glass tube containing metal filings, and a galvanometer. No current passed through the circuit since the filings are a non-conductor. When, however, the spark of an electric machine or a Leyden jar was produced in the neighbourhood of the tube, the needle of the galvanometer was powerfully deflected. The current ceased to pass when the tube containing the filings was gently

tapped, but did so when a spark was again produced, and so on. Thus the incidence of electric waves enormously diminishes the resistance of the filings; in the original condition they are separated by thin air films, and the effect of the electric radiation is to set up rapidly alternating electromotive force through the filings, bringing them into electric contact and causing them to *cohere*.

The theory of Maxwell and the experiments of Hertz have led to a fundamental change in our views as to the way in which the electric current is transmitted. It has hitherto been considered that when the circuit is closed the wire itself is the agency by which the current is transmitted. We must for the future consider that the surrounding medium, the ether, transmits the electric energy, and that this energy enters the wire from the outside; it is there destroyed as electromagnetic energy, but is converted into heat, which heat travels by radiation from layer to layer like changes of temperature in a conductor. The less the rapidity with which the electric forces change their direction in the medium, the more completely does heat penetrate the wire; when the change takes place many million times in a second the interior of the wire is not affected by the current. This is analogous to the case of a body which is subject to excessively rapid alternations of heat and cold.

In Hertz's experiments the wave-length of the radiation was of the order 6 metres. Professor J. C. Bose, of Calcutta, constructed an electric radiation apparatus of great sensitiveness in which the wave-length was reduced to 6 mm. The oscillator consisted of 3 platinum spheres arranged in a vertical line; the middle one was 4 mm. in diameter and was separated from the others (of about half the size) by very small (and adjustable) spark gaps. The small spheres were connected to the terminals of the secondary of a small Ruhmkorff coil, enclosed in an iron-lined copper box, and minute sparks passed between the small spheres and the large one. The receiver was of the coherer type, and was enclosed in a small cylinder about 70 or 80 cm. from the oscillator, in which there was a narrow vertical opening or window for the reception of the incident rays. Wires passing through lead tubing connected the terminals of the coherer to a cell and a D'Arsonval galvanometer enclosed in a metal box. The object of the metal casing was to absorb any stray radiation, and prevent its setting up electric oscillations in the circuit of the galvanometer. Outside the metal box which contained the Ruhmkorff and a storage cell was a contact key, by which the primary circuit could be made or broken. When this was pressed for an instant, one or more sparks occurred between the balls of the oscillator, and electric radiation was emitted which, when the oscillator was properly directed, fell upon the window of the receiving cylinder and produced a deflection of the spot of light.

With this apparatus Professor Bose showed that electric radiation obeys the ordinary laws of light in respect of reflection, refraction, polarisation and absorption.

1004. **Wireless telegraphy.**—Hertz's experiments were made about the year 1888; in 1896 Mr. Marconi brought over to England a system of signalling between two stations by means of electric waves, and without the intervention of conductors of any kind. Since that time great advances have been

made, and the distances signalled through increased from a few miles to 200 miles (from the Isle of Wight to Cornwall). More recently Mr. Marconi has successfully transmitted messages from Cornwall to Cape Cod and to Cape Breton.

The transmitter in Marconi's system consists of a Ruhmkorff induction coil, capable of giving a 10-inch spark in air. The terminals of the secondary are provided with polished brass balls about 2 cm. in diameter, and kept at about 1 centimetre apart (fig. 1028), but the spark gap is increased as the distance to be signalled over is greater. One of the terminals is earthed, while the other is connected with an insulated vertical conducting wire whose length is from 100 to 200 feet. This last is the essential part of the transmitter; it is called the *aerial wire*, or the *antenna*. The primary circuit of the Ruhmkorff includes a battery of about 10 volts, which is applied by a special form of key for a longer or shorter time, corresponding to the dots and dashes to be sent.

When the key is depressed sparks pass between the terminal balls of the secondary. Each spark gives rise to electric oscillations in the aerial wire, which are transmitted in all directions through the ether and fall upon a similar aerial wire at the receiving station. In the simplest form of the receiving apparatus the aerial wire (fig. 1029) is connected to earth through a coherer, and the terminals of the coherer are joined by a circuit containing cell and galvanometer or relay (914). The circuit of the galvanometer is not closed because the coherer is not a conductor; but when Hertz waves impinge upon the receiving wire oscillations are set up in it which, traversing the coherer, render it a conductor, and the galvanometer needle is deflected. Many forms of coherer have been tried; that employed by Marconi, which is at least as sensitive as any other, consists of a mixture of grains of nickel and silver contained in a small exhausted glass tube between silver electrodes very close together. When by the impact of Hertz waves the metallic powder is rendered conductive, a slight mechanical tap is necessary to restore it to its former non-conducting state. A 'tapper' is consequently a necessary part of the receiving apparatus.

In fig. 1028, A is the aerial conductor, S the spark balls in the secondary of the induction coil, K a signalling key in the primary, which can be depressed for an interval of time corresponding to a dot or a dash. Of the spark balls one is connected with the vertical conductor, the other is earthed. Fig. 1029 shows the receiver in its simplest form. The aerial wire A' is like that at the sending station—that is, the same aerial wire is used both for sending and for receiving; it is connected to earth through the coherer C. R is a relay (914) which sets in action a circuit containing a battery of 8 or 10 dry cells and a recording instrument, M.

These cells also work—by an electromagnet similar to that of an electric bell (910)—the 'tapper,' which is close to C, but is not shown in the figure. When the transmitting key is depressed for an interval of time corresponding to a dot, several sparks pass at S, giving rise to electric oscillations in the vertical conductor, A. The waves radiated from it fall on A' and set up oscillations in it whereby C becomes a conductor, and completes the circuit CR for a dot-interval of time, so that the Morse instrument at M records a dot. Similarly a longer depression of the transmitting key gives rise to a dash.

It is found that with an oscillator such as that described, known as a *simple aerial*, the oscillations are damped out very rapidly, all the energy being radiated in a few strong swings. The radiation is intense, but it lasts a very short time. The periodic time of vibration, $t = 2\pi\sqrt{LC}$, where L is the inductance and C the capacity of the oscillating system. The receiving system will absorb the incident radiation to the greatest extent when its natural period of oscillation corresponds to that of the transmitter—that is, when the transmitting and receiving circuits are in tune with each other. Hence recent experiments have been directed (1) to diminution of damping, in other words, to the maintenance of the oscillations in the transmitter;

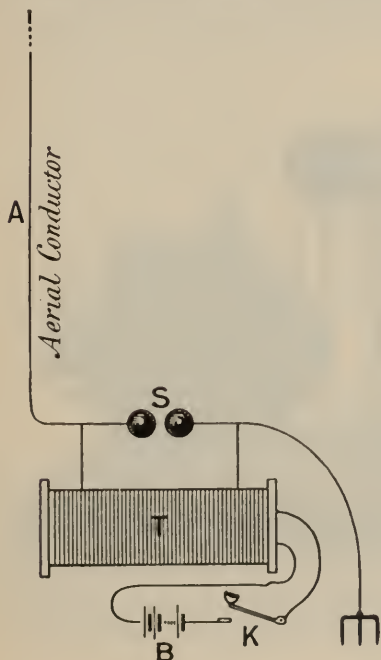

Fig. 1028

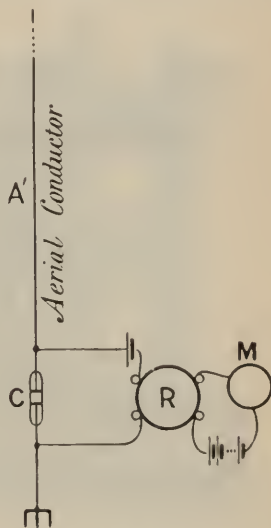

Fig. 1029

and (2) to the accurate turning of the two circuits, so as to make the product LC the same for both. Tuning, however, cannot be applied successfully to the simple aerial, on account of the rapid damping of the oscillations; further, the arrangement is only effective for short distances, since the amount of energy it can radiate is very small, being equal to $\frac{1}{2}V^2C$, where V is the difference of potential at the spark gap and C is the capacity of the condenser. If the spark gap is 1 cm., $V = 30,000$ volts, and the capacity of an aerial, 180 feet high, is about .0003 microfarad; hence it will be found that $\frac{1}{2}V^2C$ is only $\frac{1}{10}$ foot-pound. For distances greater than a few miles it is usual to connect the spark balls to a circuit containing one or more Leyden jars, an adjustable self-induction and the primary of a transformer. The

ends of the secondary of the transformer are connected respectively to the aerial and to earth. The energy thus radiated by the aerial is drawn through the transformer from the circuit containing the Leyden jars, the capacity of which may be made large.

In connection with the question of tuning we may gain some help by considering some analogous acoustic phenomena. When a loud noise is made in the neighbourhood of a piano, from the wires of which the dampers have been removed, every wire is set in vibration, quite independently of wave-length. This corresponds to a transmitter with intense but brief oscillations; all receivers in the neighbourhood, if they are sufficiently sensitive, will be affected, whatever their natural period. When, however, a note of feeble intensity, but of definite pitch, is sounded in the room where the

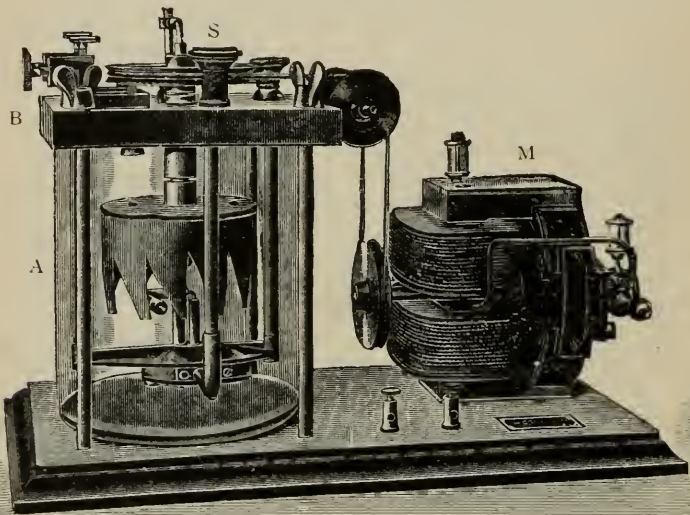

Fig. 1030

piano is, that string only will respond which is in unison with the note; the rest will be unaffected. This corresponds to the transmitter with less intense but more prolonged oscillations: a receiver in tune with it will respond; others not in tune will not respond. Resonance depends upon the accumulated effects of properly timed impulses. They may be small but they must be maintained. If the electromotive impulses acting upon a receiving circuit die away very quickly, resonant effects cannot be produced. Tuning has now been so far perfected that signals passed between the Isle of Wight and Poole (Dorsetshire) are not interfered with by those transmitted from Portsmouth to Portland, though the two lines of communication cross each other at a small angle.

For the purposes of wireless telegraphy it is desirable to have a more rapid and regular make and break for the induction coil than that with which the instrument is ordinarily provided (975), and several forms of mechanical break have been devised. Fig. 1030 shows a form in which the number of 'breaks' per second, and also the duration of each 'make,' can be greatly varied. A is a glass cylinder, with a stout ebonite lid B, through the centre of which passes a spindle which can be put into rapid rotation by means of a motor M, driven by a battery of 5 or 6 volts. The spindle has attached to it near the top a portion of a cylinder provided with a number of equidistant blades, and at the bottom an arrangement which rotates inside a fixed flat cylindrical box, seen at the bottom of the glass cylinder. This box communicates with a vertical tube, in which a small orifice is made on the side facing the blades. By

means of the knob S at the top of the tube the orifice can be raised or lowered, so that the mercury expelled from it may strike the blades at any distance from their tips. The lower part of the glass vessel contains mercury, to the height of about $1\frac{1}{2}$ inches, and the rest is filled with paraffin oil. When the spindle is set in rotation, mercury, which enters the flat cylinder by an aperture on the top, is forced up the lateral tube S, and is driven out of the small orifice in a horizontal stream against the revolving blades. If this apparatus is inserted between the battery (10 volts) and the primary of the induction coil, and the cylinder with its blades rotated by the motor, the circuit is made and broken by the mercury meeting the blades or passing through the spaces between them. The mercury can be made to impinge upon the broad or the narrow parts of the blades at pleasure, thus altering the duration of the 'make.'

The success which has been attained in transmitting signals through great distances is partly due to the use of a specially constructed transformer (994) in the receiving circuit, commonly called a *jigger*. Instead of connecting the vertical receiving wire in series with the coherer, as in fig. 1029, it is connected with the primary, P, of this transformer (fig. 1031), the secondary, S, of which is in series with the coherer C, cell B, and relay R. A condenser, K, is inserted between a and b. By this arrangement the voltage of the received oscillations is increased in the ratio of about 10 to 1, and the resistance of the coherer more easily broken down. Tuning

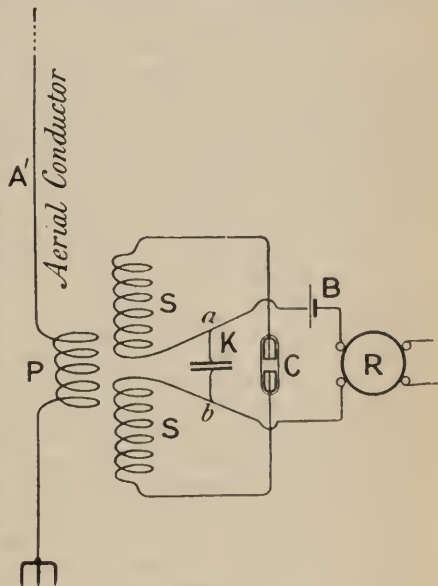

Fig. 1031

is effected by varying the self-induction of the aerial wire, and the capacity of the condenser K, and in other ways, the object being to make LC the same for the transmitting and the receiving apparatus.

Various other forms of receiver are employed besides the coherer. Dr. DeForest's receiver (or *responder*) is a small electrolytic cell, the anode being a very fine platinum wire, the kathode a small cup of platinum, and the electrolyte nitric acid or potash. The circuit is completed through a cell and a telephone, but in consequence of polarisation there is ordinarily no current round the circuit. The arrangement is that of fig. 1029, C being now the electrolytic receiver, and R being replaced by a telephone. When electric waves reach the aerial, oscillations are set up in the electrolyte which destroy the polarisation so long as they last, and so give rise to sounds in the telephone.

In the *magnetic detector*, a new receiver devised by Marconi, the aerial is connected to earth through a small helix (call it P) about 5 cm. long and 0.6 cm. in diameter. Through the helix a continuous band of fine stranded iron wire is constantly moving by clockwork, and as it passes through is magnetised by an externally placed steel magnet. When the iron wire leaves the influence of the magnet its induced magnetism does not entirely disappear, but is partially retained in consequence of hysteresis (907). The effect of electric waves impinging on the aerial is to start electric oscillations which traverse the helix and destroy the hysteresis. This effect is at once detected by a telephone in a circuit containing a small flat coil (call it S) which envelops the coil P. The magnetic detector is very sensitive; it is used in liners as they cross the Atlantic for the reception of news from Poldhu (Cornwall), or Cape Cod (Massachusetts). No jigger is required with this receiver or with that of DeForest. Tuning is effected by altering the number of turns of wire in a coil which connects the aerial with the helix P, and so altering the value of the self-inductance in the receiving circuit. The drawback at present to the general employment of these receivers is that they must be used in conjunction with a telephone, and thus no permanent record remains of the signal or message received. This objection cannot be urged against a very ingenious receiver invented by Sir Oliver Lodge, and used in the Lodge-Muirhead system of wireless telegraphy. It is of the coherer type, and consists of a small thin steel disc whose lower edge, as the disc rotates about a horizontal axis, is immersed in a small vessel of mercury covered with a thin layer of paraffin oil. The axis of the disc and the mercury are connected respectively with the aerial and earth as in fig. 1029, and are also connected with a circuit containing a cell and a siphon recorder (917). The electric contact of the steel disc and the mercury is so poor in consequence of the layer of oil that practically no current passes through the siphon recorder, but the insulation is broken down when electric waves impinge upon the aerial wire, being instantly re-established by the rotation of the disc. Consequently no tapper is required and a permanent record is obtained of the signals received. This apparatus has been found to answer well for moderate distances.

1005. **Penetration of rapidly alternating currents and oscillatory currents into a conductor.**—If we consider a conducting wire as made up of a number

of parallel conducting filaments, an alternating current passing through any particular filament will be impeded by the induction due to currents in the neighbouring filaments, and their effect will be most felt in the axis of the wire. Consequently the currents will be stronger nearer the circumference than in the middle. If the alternations are sufficiently rapid the current will be practically confined to the *skin* of the conductor, the skin being defined as the thickness in which the strength of the current falls to $1/\epsilon$ or $\cdot37$ of its value at the surface. If n , the frequency of the alternations, = 100, the thickness of the skin is $\cdot5$ mm. for iron, and $6\cdot5$ mm. for copper. But if $n = 10^6$, as in the oscillatory discharge of a Leyden jar or Hertz vibrator, the thickness of the skin is $\cdot005$ mm. for iron, and $\cdot07$ mm. for copper. Hence, since a lightning discharge is oscillatory, a lightning conductor of comparatively thin copper ribbon or stranded iron wire is as serviceable as a massive rod, and cheaper.

CHAPTER XV

PHYSIOLOGICAL ACTION OF THE CURRENT. ANIMAL ELECTRICITY

1006. **Physiological actions.**—Under this name are included the effects produced by a battery current on living organisms or tissues.

When the electrodes of a battery of many cells are grasped by the two hands a violent shock is felt, especially if the hands are moistened with acidulated water, which increases the conductivity. The violence of the shock increases with the number of elements used, and with a large number—as 200 Bunsen's cells, giving an electromotive force of 360 volts—is even dangerous.

The power of contracting upon the application of a voltaic current seems to be a very general property of *protoplasm*—the physical basis of both animal and vegetable life ; if, for example, a current of moderate strength is passed through such a simple form of protoplasm as an amœba, it immediately withdraws its processes, ceases its changes of form, and contracts into a rounded ball—soon, however, resuming its activity upon the cessation of the current. Essentially similar effects of the current have been observed in the protoplasm of young vegetable cells.

If a frog's fresh muscle (which will retain its vitality for a considerable time after removal from the body of the animal) is introduced into a galvanic circuit, no apparent effect will be observed during the steady passage of the current, but every opening or closure of the circuit will cause a muscular contraction, as will also any sudden and considerable alteration in the strength of the current. By very rapidly interrupting the current the muscle can be thrown into a state of uninterrupted contraction, or physiological *tetanus*, each new contraction occurring before the previous one has passed off. Other things being equal, the amount of shortening exhibited by the muscles increases, up to a certain limit, with the intensity of the current. These phenomena entirely disappear with the life of the muscle ; hence the experiments are somewhat more difficult with warm-blooded animals, the vitality of whose muscles, after exposure or removal from the body, is maintained with more difficulty ; but the results of careful experiment are exactly the same here as in the case of the frog.

The influence of an electric current upon living nerves is very remarkable ; as a general rule, it may be stated that its effect is to throw the nerve into a state of activity, whatever its special function may be : thus, if the nerve is one going to a muscle, the latter will be caused to contract ; if it is one of common sensation, pain will be produced ; if one of special sense, the sensation of a flash of light, or of a taste, &c., will be produced, according to the nerve irritated. These effects do not manifest themselves during the even passage of the current, but only when the circuit is either opened or

closed or both. Of course the continuity of the nerve with the organ where its activity manifests itself must be maintained intact. The changes set up by the current in the different nerve-trunks are probably similar, the various sensations, &c., produced depending on the different terminal organs with which the nerves are connected.

If a powerful electric current is passed through the body of a recently killed animal, violent movements are produced, as the muscles ordinarily retain their vitality for a considerable time after general systemic death: by this means, also, life has been re-established in animals which were apparently dead—a properly applied current stimulating the respiratory muscles to contract.

Burdon Sanderson found that the movement which causes the *Dionæa muscipula* (Venus's fly-trap), one of those which are called *carnivorous plants*, to close its hairy leaves and thereby entrap insects which alight upon it, is accompanied by an electric current in a manner analogous to that manifested in muscular contraction. The manner in which the irritation is caused seems immaterial.

1007. **Muscular currents.**—The existence of electric currents in living muscle was first indicated by Galvani, but his researches fell into oblivion after the discovery of the voltaic pile, which was supposed to explain all the phenomena. Since then, Nobili, Matteucci, Du Bois Reymond, and others, have shown that electric currents do exist in living muscles and nerves.

For investigating these currents it is necessary to have a delicate galvanometer, and also electrodes which will not become polarised or give a current of their own, and which will not in any way alter the muscle when placed in contact with it; the electrodes which satisfy these conditions best (*non-polarisable electrodes*) are those of Du Bois Reymond, as modified by Donders. Each consists of a glass tube, one end of which is narrowed and stopped by a plug of paste made by moistening china-clay with a solution of common salt; the tube is then partially filled with a saturated solution of zinc sulphate; and into this dips the end of a piece of thoroughly amalgamated zinc wire, the other end of which is connected by a copper wire with the galvanometer; the moistened china-clay is a conducting medium which is perfectly neutral to the muscle, and amalgamated zinc in solution of zinc sulphate does not become polarised. The ordinary galvanometer has been superseded in many physiological investigations by the capillary electrometer of Lippmann (950).

1008. **Currents of muscle at rest.**—If a living irritable muscle is removed from a recently killed frog, and if one electrode is placed in contact with its surface, and the other with its tendon, the galvanometer will indicate a current from the former to the latter; showing, therefore, that the surface of the muscle is positive with respect to the tendon. By varying the position of the electrodes, and making various artificial sections, it is found—

1. That any longitudinal section is positive to any transverse section.
2. That any point of a longitudinal section nearer the middle of the muscle is positive to any other point of the same section farther from the centre.
3. In any artificial transverse section any point nearer the periphery is positive to one nearer the centre.

4. The current obtained between two points in a longitudinal or in a transverse section is always much more feeble than that obtained between two different sections.

5. No current is obtained if two points of the same section equidistant from its centre are taken.

6. To obtain these currents it is not necessary to employ a whole muscle or a considerable part of one, but the smallest fragment that can be experimented with is sufficient.

To explain the existence and relations of these muscular currents it may be supposed that each muscle is made up of regularly disposed electromotor elements which may be regarded as cylinders whose axes are parallel to that of the muscle, and whose sides are charged with positive and their ends with negative electricity; and, further, that all are suspended and enveloped in a conducting medium. In such a case it is clear that throughout most of the muscle the positive electricities of the opposed surfaces would neutralise one another, as would also the negative charges of the ends of the cylinders; so that, so long as the muscle was intact, only the charges at its sides and ends would be left to manifest themselves by the production of electromotive phenomena; the whole muscle being enveloped in a conducting stratum, a current would constantly be passing from the longitudinal to the transverse section, and, a part of this being led off by the wire circuit, would manifest itself in the galvanometer.

A perfectly fresh muscle, very carefully removed, with the least possible contact with foreign matters, sometimes gives almost no current between its different natural sections, and the current always becomes more marked after the muscle has been exposed a short time; nevertheless, the phenomena are vital, for the currents disappear completely with the life of the muscle, sometimes becoming first irregular or even reversed in direction.

1009. **Rheoscopic frog. Contraction without metals.**—The existence of the muscular currents can be manifested without a galvanometer, by using another muscle as a galvanoscope. Thus, if the nerve of one living muscle of a frog is dropped suddenly on another living muscle, so as to come in contact with its longitudinal and transverse sections, a contraction of the first muscle will occur, due to the stimulation of its nerve by the passage through it of the electric current derived from the surface of the second.

1010. **Currents in active muscle.**—When a muscle is made to contract there occurs a sudden diminution of its natural electric current, as indicated by the galvanometer. This is so instantaneous that, in the case of a single muscular contraction, it does not overcome the inertia of the needle of the galvanometer; but if the contractions are made to succeed one another very rapidly—that is, if the muscle is *tetanisèd*—then the needle swings steadily back towards zero from the position in which the current of the resting muscle had kept it, often gaining such momentum in the swing as to pass beyond the zero point, but soon reverting to some point between zero and its original position.

The negative variation in the case of a simple muscular contraction can, however, be made manifest by using another muscle as a rheoscope; if the nerve of this second muscle is laid over the first muscle in such a position that the muscular current passes through it, and the first muscle is then made

to contract, the sudden alteration in its strength of the current stimulates the nerve laid on it, and so causes a contraction of the muscle to which the latter belongs.

The same phenomenon can be demonstrated in the muscles of warm-blooded animals ; but with less ease, on account of the difficulty of keeping them alive after they are laid bare or removed from the body. Experiments made by placing electrodes outside the skin, or passing them through it, are inexact and unsatisfactory.

1011. **Electric currents in nerve.**—The same electric indications can be obtained from nerves as from muscles—at least as far as their smaller size will permit ; the currents are more feeble than the muscular ones, but can be demonstrated by the galvanometer in a similar way. Negative variation has been proved to occur in active nerve as in active muscle. The effect of a constant current passed through one part of a nerve on the amount of the normal nerve-current, measured at another part, has already been described.

1012. **Electric fish.**—Electric fish are those fish which have the remarkable property of giving, when touched, shocks like those of the Leyden jar. Of these fish there are several species, the best known of which are the torpedo, the gymnotus, and the silurus. The torpedo, which is very common in the Mediterranean, was carefully studied by Becquerel and Breschet in France, and by Matteucci in Italy. The gymnotus was investigated by Humboldt and Bonpland in South America, and in England by Faraday, who had the opportunity of examining live specimens.

The shock which they give serves as a means both of offence and of defence. It is purely voluntary, and becomes gradually weaker as it is repeated and as these animals lose their vitality, for the electric action soon exhausts them materially. According to Faraday, the shock which the gymnotus gives is equal to that of a battery of 15 jars exposing a coating of 25 square feet, which explains how it is that horses frequently give way under the repeated attacks of the gymnotus.

Numerous experiments show that these shocks are due to ordinary electricity. For if, touching with one hand the back of the animal, the belly is touched with the other, or with a metal rod, a violent shock is felt in the wrists and arms ; while no shock is felt if the animal is touched with an insulating body. Further, when the back is connected with one end of a galvanometer wire and the belly with the other, at each discharge the needle is deflected, but immediately returns to zero, which shows that there is an instantaneous current ; and, moreover, the direction of the needle shows that the current goes externally from the back to the belly of the fish. Lastly, if the current of a torpedo be passed through a helix in the centre of which is a small steel bar, the latter is magnetised by the passage of a discharge.

By means of the galvanometer, Matteucci established the following facts :—

1. When a torpedo is lively, it can give a shock in any part of its body, but as its vitality diminishes, the parts at which it can give a shock are nearer the organ which is the seat of the development of electricity.
2. Any point of the back is always positive as compared with the corresponding point of the belly.
3. Of any two points at different distances from

the electric organ, the nearer always plays the part of a positive pole, and the farther that of a negative pole. With the belly the reverse is the case.

The organ where the electricity is produced in the torpedo is double, and formed of two parts symmetrically situated on two sides of the head and attached to the skull-bone by the internal face. Each part consists of nearly parallel lamellæ of connective tissue enclosing small chambers, in which lie the so-called *electric plates*, each of which has a final nerve ramification distributed on one of its faces. The face, on which the nerve ends, is turned the same way in all the plates, and when the discharge takes place is always negative to the other.

Matteucci investigated the influence of the brain on the discharge. For this purpose he laid bare the brain of a living torpedo, and found that the first three lobes could be irritated without the discharge being produced, and that when they were removed the animal still possessed the faculty of giving a shock. The fourth lobe, on the contrary, could not be irritated without an immediate production of the discharge; but if it was removed, all disengagement of electricity disappeared, even if the other lobes remained untouched. Hence it would appear that the primary source of the electricity elaborated is the fourth lobe, whence it is transmitted by means of the nerves to the two organs described above, which act as multipliers. In the silurus the head appears also to be the seat of the electricity; but in the gymnotus it is found in the tail.

1013. **Application of electricity to medicine.**—The first applications of electricity to medicine date from the discovery of the Leyden jar. Nollet and Bose appear to have been the first who thought of the application, and soon the spark and electric friction became a universal panacea; but it must be admitted that the results of subsequent trials did not come up to the hopes of the early experimentalists.

After the discovery of dynamic electricity Galvani proposed its application to medicine; since which time many physicists and physiologists have been engaged upon this subject, and yet there is still much uncertainty as to the real effects of electricity, the cases in which it is to be applied, and the best mode of applying it. Practical men prefer the use of currents to that of statical electricity, and, except in a few cases, discontinuous to continuous currents. There is, finally, a choice between the currents of the battery and induction currents; further, the effects of the latter differ, according as induction currents of the first or second order are used. In fact, since induction currents, although very intense, have a very feeble chemical action, it follows that when they traverse the organs they do not produce the chemical effects of the current of the battery, and hence do not tend to produce the same disorganisation. Further, in electrifying the muscles of the face, induction currents are to be preferred, for these currents only act feebly on the retina, while the currents of the battery act energetically on this organ, and may affect it dangerously. There is a difference in the action of induced currents of different orders; for while the primary induced current causes lively muscular actions, but has little action on the cutaneous sensibility, the secondary induced current, on the contrary, increases the cutaneous sensibility to such a point that its use ought not to be prescribed to persons whose skin is very irritable.

Hence electric currents should not be applied in therapeutics without a thorough knowledge of their various properties. They ought to be used with great prudence, for their continued action may produce serious accidents. Matteucci says : 'In commencing, a feeble current must always be used. This precaution now seems to me the more important as I did not think it so before seeing a paralytic person seized with almost tetanic convulsions under the action of a current formed of a single element. Take care not to continue the application too long, especially if the current is energetic. Rather apply a frequently interrupted current than a continuous one, especially if it be strong ; but after twenty or thirty shocks, at most, let the patient take a few moments' rest.'

Röntgen or *X*-rays (983) are extensively employed for the examination of various parts of the body and for the localisation of foreign substances, such as needles, bullets, &c., in the body. The part to be examined (*e.g.* the wrist) is placed on a table over a prepared photographic plate wrapped in black paper which is impervious to ordinary light. The focus tube (983) is then arranged about 15 inches above the wrist and is set in action. The time of exposure depends on the part of the body which is being examined ; for the wrist 15 seconds would be sufficient, for the thigh or the abdomen 5 or 6 minutes. The exposure depends upon the size and power of the induction coil and also on the size of the focus tube. The higher the degree to which the vacuum in the tube has been carried, the greater is the E.M.F. required to produce the kathode discharge and the greater the penetration of the *X*-rays. Tubes are thus distinguished as 'hard' and 'soft,' a 'soft' tube being one in which the rays have less penetration power, and which is often preferred as showing more sharply the contrast between the bones and the fleshy part of the body.

ELEMENTARY OUTLINES
OF
METEOROLOGY AND CLIMATOLOGY

METEOROLOGY

1014. **Meteorology.**—The phenomena which are produced in the atmosphere are called *meteors*; and *meteorology* is that part of physics which is concerned with the study of these phenomena.

A distinction is made between *aerial* meteors, such as winds, hurricanes, and whirlwinds; *aqueous* meteors, comprising fogs, clouds, rain, dew, snow, and hail; and *luminous* meteors, as lightning, the rainbow, and the aurora borealis.

1015. **Meteorograph.**—The importance of being able to make continuous observations of various meteorological phenomena has led to the construction of various forms of automatic arrangements for this purpose, of which that of Osler in England may be mentioned. One of the most comprehensive and complete is Secchi's *meteorograph*, which consists of a base of masonry about 2 feet high (fig. 1032); on this are fixed four columns about $2\frac{1}{2}$ yards high which support a table on which is a clockwork regulating the whole of the movements. The phenomena are registered on two sheets which move downwards on two opposite sides, their motion being regulated by the clockwork. One of them occupies ten days in so doing, and on it are registered the direction and velocity of the wind, the temperature of the air, the height of the barometer, and the occurrence of rain; on the second, which only takes two days, the barometric height and the occurrence of rain are repeated, but on a much larger scale; this gives moreover the moisture of the air.

Direction of the wind.—The four principal directions of the wind are registered by means of four pencils fixed at the top of thin brass rods, *a, b, c, d* (fig. 1032), which are provided at the bottom ends with soft-iron keepers attracted by two electromagnets, *E E'*, for west and north, and by two other electromagnets lower down for south and east. These four electromagnets, as well as all the others on the apparatus, are worked by a single battery of twenty-four cells. The passage of the current in one or another

of these electromagnets is regulated by means of a vane (fig. 1032) consisting of two plates at an angle of thirty degrees with each other, by

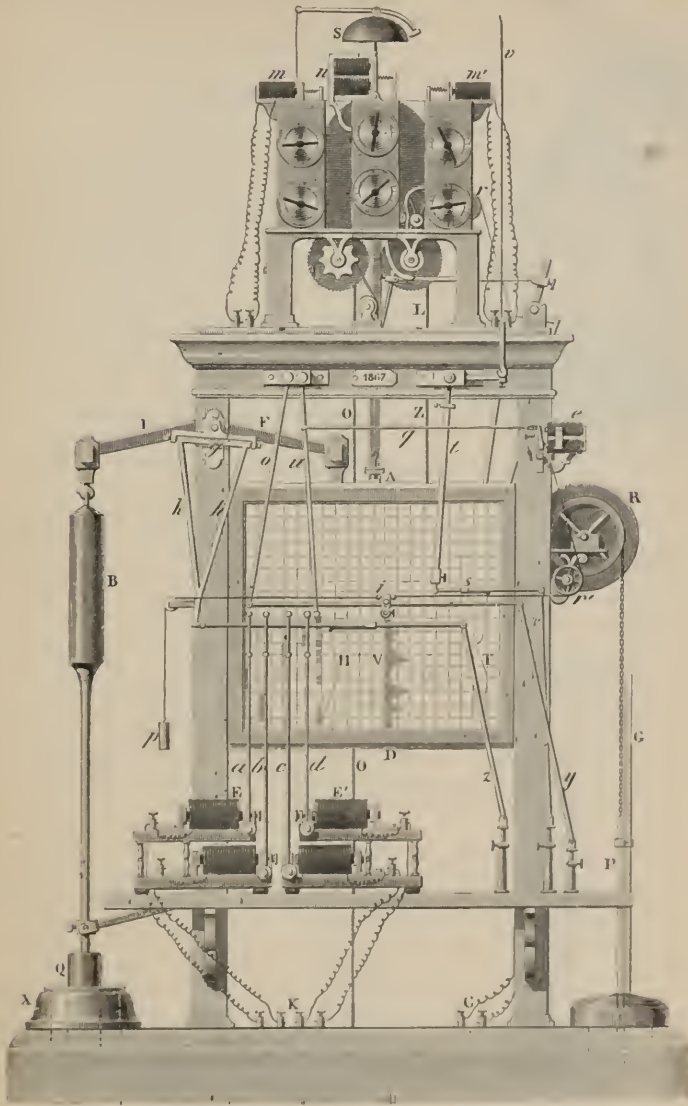

Fig. 1032

which greater steadiness is obtained than with a single plate. In the rod of the vane is a small brass plate, *o* ; this part is in the centre of four metal

sectors, insulated from each other, and each provided with a binding-screw, by which connection is established with the binding-screws K, and the electromagnets E E'. The battery current reaches the rod of the vane by the wire *a*, and passes thence to the sliding contact *o*, which leads it to the electromagnet for the north, for instance.

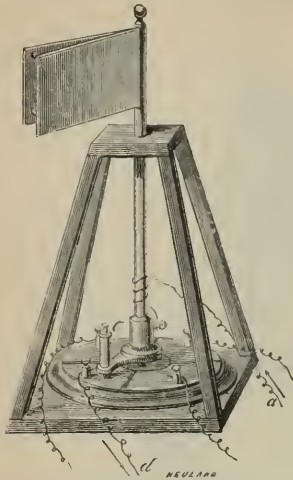

Fig. 1033

and its pencil traces a different series of marks. The rate of displacement of the paper being known, we get the direction of the prevalent wind at a given moment.

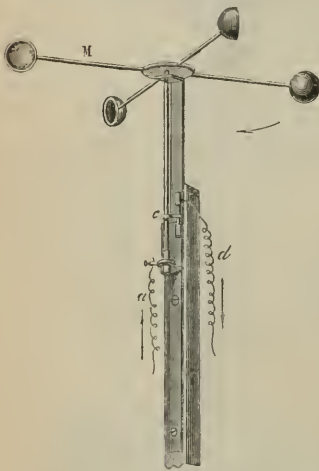

Fig. 1034

If the current passed constantly in this electromagnet, the pencil on the rod *d* would be stationary; but from the electromagnet E' the current passes into a second electromagnet, *n*, over the clockwork, and its circuit is thereby alternately opened and closed, as will be seen when we speak of the velocity of the wind. Hence the armature of the rod *d*, alternately free and attracted, oscillates; and its pencil, which is always pressed against the paper AD by the elasticity of the rod, traces on it a series of parallel dashes as the paper descends, and so long as the wind is in the north. If the wind changes then to west, for instance, the rod *a* oscillates and its pencil traces a different series of marks. The rate of displacement of the paper being known, we get the direction of the prevalent wind at a given moment.

Velocity of the wind.—This is indicated by a Robinson's *anemometer*, and is registered in two ways: by two counters which mark in decametres and kilometres the distance travelled by the wind; and by a pencil which traces on a table a curve, the ordinates of which are proportional to the velocity of the wind.

Robinson, who originally devised this form of anemometer (fig. 1034), proved that its velocity is proportional to that of the wind; in this apparatus the length of the arms is so calculated that each revolution corresponds to a velocity of 10 metres. The anemometer is placed at a considerable distance from the meteorograph, and is connected with it by a copper wire, *d*, which passes to the electromagnet, *n*, of the counter. On its rod there is, moreover, an excentric, which at each turn touches a metal contact in connection with the wire *d*. The battery current reaches the anemometer by a wire *a*, the circuit is closed once at each revolution, and the current passes to the electromagnet *n*, which

moves the needle of the dial through one division. There are fifty such divisions, which represent as many turns of the vane, and therefore so many multiples of 10 metres. The lower dial marks the kilometres.

The curve of velocities is traced on the sheet by a pencil, i , fixed to a horizontal rod. This is joined at its two ends to two guide-rods, o and y , which keep it horizontal. The pencil and the rod are moved laterally by a chain which passes over two pulleys, r' and r , and is then coiled over a pulley placed on the shaft of the counter, but connected with it merely by a ratchet-wheel; and moved thus by the counter and the chain, the pencil traces every hour on the sheet a line the length of which is proportioned to the velocity of the wind. From hour to hour an excentric moved by clockwork detaches, from the shaft of the counter, the pulley on which is coiled the chain, and this pulley becoming out of gear, a weight, p , connected with the pencil, i , restores the pencil to its starting-point. All the lines, V , traced successively by the pencil, start as ordinates from the same straight line, and their ends give the curve of velocities.

The counters on the right and left are worked by electromagnets, $m m'$, and are intended to denote the velocity of special winds; for instance, those of the north and south, by connecting their electromagnets with the north and south sectors of the vane (fig. 1033).

Temperature of the air.—This is indicated by the expansion and contraction of a copper wire of 16 metres in length stretched backwards and forwards on a fir post 8 metres in length. The whole being placed on the outside—on the roof for instance—the expansion and contraction are transmitted by a system of levers to a wire, v , which passes to the meteorograph, where it is jointed to a bent lever, t . This is jointed to a horizontal rod, s , which supports a pencil, and at the other end is jointed to a guide-rod, x . Thus the pencil, sharing the oscillations of the whole system, traces the curve of the temperatures.

Pressure of the atmosphere.—This is registered by the oscillations of a barometer, B , suspended at one end of a bent scale-beam, $1F$, playing on a knife-edge (fig. 1036). The arm F supports a counterpoise; to the arm I is suspended the barometer B , which is wider at the top than at the bottom. A wooden flange or floater, fixed to the lower part of the tube, plunges in a bath of mercury, so that the buoyancy of the liquid counterbalances part of the weight of the barometer. Owing to the large diameter of the barometric chamber, a very slight variation of level in this chamber makes the tube oscillate, and with it the scale-beam $1F$. To the axis of this is attached a triangle, ghk (fig. 1032), jointed to a horizontal rod, which in turn is connected with a guide-rod, z . In the middle of this rod is a pencil which, sharing in the oscillations of the triangle ghk , traces the curve H of pressure. A bent lever at the bottom of the barometer tube keeps the latter in a vertical position.

Rainfall.—This is registered between the direction of the winds and the curve H by a pencil at the end of a rod, u , which is worked by an electromagnet, e . On the roof is a funnel which collects the rain, and a long tube leads the water to a small water-balance with the cups placed near the meteorograph (fig. 1035). To the axis of the scale-beam one pole of the battery is connected; the left cup being full, tips up, and a contact, a , closes the circuit, and the current passes then to one of the binding-screws,

C (fig. 1032), and hence to the electromagnet, *e*. Then the right cup, being in turn full, tips in the opposite direction, and the contact *b* now transmits the current to the electromagnet. Thus, at each oscillation, this latter attracts its armature, and with it the rod *u*, which makes a mark by means of a pencil at the end. If the rain is abundant, the oscillations of the beam are rapid, and the marks, being very close together, give a deep shade; if, on the contrary, the oscillations are slow, the marks are at a greater distance, and give a light shade. When the rain ceases the oscillations cease also, and the pencil makes no mark.

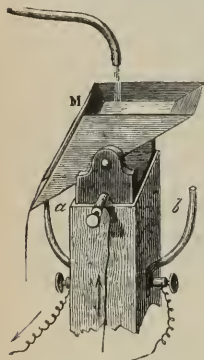

Fig. 1035

To complete this description of the first face of the meteorograph: *S* is the alarm-bell of the clock-work; *OO* a cord supporting a weight which moves the works of the hour-hand; *LZ* is a second cord that supports the weight which works the alarm; the wheel *U*, placed below the clockwork, winds up the sheet *AD* when it is at the bottom of its course.

The second sheet (fig. 1036) gives the barometric height and the rainfall like the first, but on a larger scale, since the motion of the sheet is five times as rapid. Its principal function is that of registering the moisture of the air. This is effected by means of the *psychrometer* (fig. 1037). *T* and *T'* are two thermometers fixed on two plates. The muslin which covers

the second is kept continually moist by water dropping on it. In each of the bulbs is fused a platinum wire; the stems of the thermometers are open at the top, and in them are two platinum wires, *m* and *n*, suspended to a metal frame movable on four pulleys supported by a fixed piece, *B*. The frame *A*, in contact with the current of the battery, is suspended to a steel wire, *L*, which passes over a pulley to the meteorograph (fig. 1036). Here is a long triangular lever, *W*, which supports a small wheel, to which is fixed the wire *L*. The lever *W*, which turns about an axis, *f*, is moved by a rod, *a*, by means of an excentric, which the clock works every quarter of an hour. At each oscillation the lever *W* transmits its motion to a small chariot, on which is an electromagnet, *x*, and at the same time to the steel wire *L*, which supports the frame *A* (fig. 1037). The chariot, moved towards the left by the rotation of the excentric, lets the frame sink. The moment the first platinum wire reaches the mercurial column of the dry-bulb thermometer, which is the highest, the circuit is closed, and the current passes into the electromagnet of the chariot. An armature at once causes a pencil to mark a point on the sheet which is the beginning of a line representing the path of the dry-bulb thermometer. As the frame continues to descend, the second platinum wire touches the mercury of the wet bulb, and causes a current to flow in a relay, *M*, which opens the circuit of the electromagnet, *x*. The pencil is then detached; then, returning upon itself, the chariot reproduces the closing and opening of the circuit in the opposite direction, the pencil making another mark, which is the end of the line. There are thus formed two series of dots arranged in two curves, one of which represents the path of the dry, and the other the path of the wet, bulb. The horizontal distance of the two points of these curves is proportional to the

difference $t-t_1$ of the temperatures indicated at the same moment by the thermometers (fig. 1037).

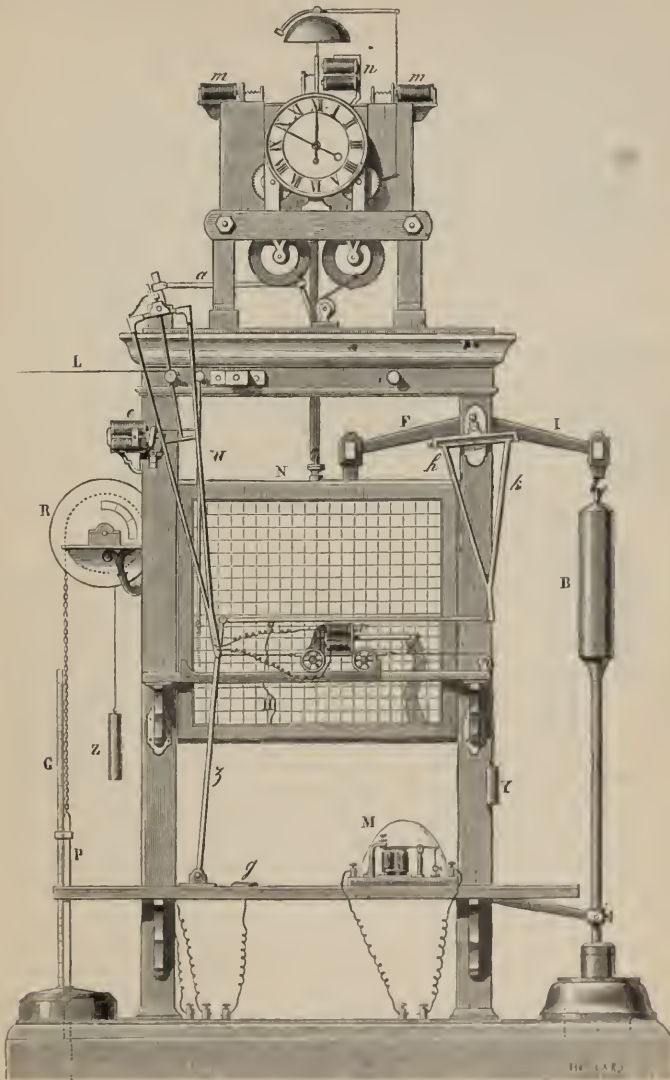

Fig. 1036

Quantity of rain.—The quantity of rain which falls in a given time is registered on a disc of paper on a pulley, R. On the groove of this is coiled a chain to which is suspended a brass tube, P. This is fixed at the

bottom to a float, which plunges in a reservoir placed in the base of the meteorograph. On passing out of the water-balance (fig. 1035) the water passes into this reservoir, and as its section is one-fourth that of the funnel, the height of water which falls is quadrupled; it is measured on a scale, G, divided into millimetres.

As the float rises, a weight, Z, moves the pulley in the contrary direction, and its rotation is proportional to the height of water which has fallen. A

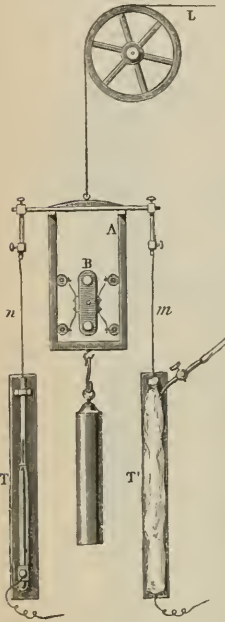

Fig. 1037

pencil moves at the same time from the centre to the circumference of the paper disc with a velocity of 5 mm. in 24 hours: hence the quantity of rain which falls every day is noted on a different place on the paper disc.

1016. **Direction and velocity of winds.**—*Winds* are currents moving in the atmosphere with variable directions and velocities. There are eight principal directions in which they blow—*north, north-east, east, south-east, south, south-west, west, and north-west*. Mariners further divide each of the distances between those eight directions into four others, making in all 32 directions, which are called *points* or *rhumbs*. A figure of 32 rhumbs on a circle, in the form of a star, is known as the *mariner's card*.

Velocity is determined by means of the *anemometer* (fig. 1034), a small vane with fans, which the wind turns; the velocity is deduced from the number of turns made in a given time. In our climate the mean velocity is from 18 to 20 feet in a second. With a velocity of less than 18 inches in a second no movement is perceptible, and smoke ascends straight; with a velocity between $1\frac{1}{2}$ and 2 feet per second the wind is perceptible and moves a pennant; from 13 to 22 feet it is moderate,

it stretches a flag and moves the leaves of trees; with from 23 to 36 feet velocity it is fresh, and moves the branches of trees; with 36 to 56 feet it is strong, and moves the larger branches and the smaller stems; with a velocity of 56 to 90 feet it is a storm, and entire trees are moved; and from 90 to 120 it is a hurricane.

To measure the pressure of the wind a plate is used, which by means of a vane is always kept in a direction facing the wind. Behind the plate are one or more springs, which are the more pressed the greater is the pressure of the wind against the plate. Knowing the distance through which the plate is pressed, we can calculate the pressure which the wind exerts on the plate in question.

With some degree of approximation, and for low velocities, the pressure may be taken as proportional to the square of the velocity. Thus, if the pressure on the square foot is 0.005 pound with a velocity of 1.5 foot in a second, it is 0.02 pound with a velocity of 3 feet, and 0.123 with a velocity of 7.33 feet.

1017. **Causes of winds.**—Winds are produced by a disturbance of the equilibrium in some part of the atmosphere: a disturbance always resulting from a difference in temperature between adjacent countries. Thus, if the temperature of a certain extent of ground becomes higher, the air in contact with it becomes heated, expands and rises towards the higher regions of the atmosphere; whence it flows, producing winds which blow from hot to cold countries. But at the same time the equilibrium is destroyed at the surface of the earth, for the barometric pressure on the colder adjacent parts is greater than on that which has been heated, and hence a current will be produced with a velocity dependent on the difference between these pressures: thus two distinct winds will be produced—an upper one setting *outwards* from the heated region, and a lower one setting *inwards* towards it.

1018. **Regular, periodic, and variable winds.**—According to the more or less constant directions in which winds blow, they may be classed as regular, periodic, and variable winds.

i. *Regular winds* are those which blow all the year through in a virtually constant direction. These winds, which are also known as the *trade winds*, are uninterruptedly observed far from the land in equatorial regions, blowing from the north-east to the south-west in the Northern Hemisphere, and from the south-east to the north-west in the Southern Hemisphere. They prevail on the two sides of the equator as far as 30° of latitude, and they blow in the same direction as the apparent motion of the sun—that is, from east to west.

The air above the equator being gradually heated, rises as the sun passes round from east to west, and its place is supplied by the colder air from the north or south. The direction of the wind, however, is modified by this fact, that the velocity which this colder air has derived from the rotation of the earth—namely, the velocity of the surface of the earth at the point from which it started—is less than the velocity of the surface of the earth at the point at which it has now arrived: hence the currents acquire, in reference to the equator, the constant direction which characterises the trade winds.

ii. *Periodic winds* are those which blow regularly in the same direction at the same seasons and at the same hours of the day: the monsoon, simoon, and the land and sea breeze are examples of this class. The name *monsoon* is given to winds which blow for six months in one direction and for six months in another. They are principally observed in the Red Sea and in the Arabian Gulf, in the Bay of Bengal and in the Chinese Sea. These winds blow towards the continents in summer, and in a contrary direction in winter. The *simoon* is a hot wind which blows over the deserts of Asia and Africa, and which is characterised by its high temperature and by the sands which it raises in the atmosphere and carries with it. During the prevalence of this wind the air is darkened, the skin feels dry, the respiration is accelerated, and a burning thirst is experienced.

This wind is known under the name of *sirocco* in Italy and Algiers, where it blows from the great desert of Sahara. In Egypt, where it prevails from the end of April to June, it is called *kamsin*. The natives of Africa, in order to protect themselves from the effects of the too rapid perspiration occasioned by this wind, cover themselves with fatty substances.

A wind characteristic of Switzerland and known as the *Föhn* originates as

follows : a mass of air coming from the south-east being impelled over a mountain ridge becomes rarefied as it ascends ; the temperature falls, and it deposits its moisture on the other side as rain or snow. Being driven still forward into the valleys, the superincumbent pressure being greater, the air is condensed, and its temperature rises, and having parted with its moisture it appears as a wind which is at once hot and dry. One observation gave the temperature at 31.4° C., while it only contained 20 per cent. of moisture.

The *land and sea breeze* is a wind which blows on the sea-coast, during the day from the sea towards the land, and during the night from the land to the sea. For during the day the land becomes more heated than the sea, in consequence of its lower specific heat and greater conductivity, and hence, as the superincumbent air becomes more heated than that upon the sea, it ascends and is replaced by a current of colder and denser air flowing from the sea towards the land. During the night the land cools more rapidly than the sea, and hence the same phenomenon is produced, but in a contrary direction. The sea breeze commences after sunrise, increases up to three o'clock in the afternoon, decreases towards evening, and is changed into a land breeze after sunset. These winds are only perceived at a slight distance from the shore. They are regular in the tropics, but less so in our climates ; traces of them are seen as far as the coasts of Greenland. The proximity of mountains, and also of forests, likewise gives rise to periodical daily breezes.

iii. *Variable winds* are those which blow sometimes in one direction and sometimes in another, alternately, without being subject to any law. In mean latitudes the direction of the wind is very variable ; towards the poles this irregularity increases, and under the arctic zone the winds frequently blow from several points of the horizon at once. On the other hand, in approaching the torrid zone they become more regular. The south-west wind prevails in England, in the north of France, and in Germany ; in the south of France the direction inclines towards the north, and in Spain and Italy the north wind predominates.

1019. **Law of the rotation of winds.**—Notwithstanding the great irregularity which characterises the direction of the winds in our latitude, it has been ascertained that the wind has a preponderating tendency to veer round according to the sun's motion—that is, to pass from north, through north-east-south-east to south, and so on round in the same direction from west to north ; that it often makes a complete circuit in that direction, or more than one in succession, occupying many days in doing so, but that it rarely veers, and very rarely or never makes a complete circuit in the opposite direction. This course of the winds is most regularly observed in winter. According to Leverrier, the displacement of the north-east by the south-west wind arises from the occurrence of a whirlwind formed upon the Gulf Stream. For a station in south latitude a contrary law of rotation prevails.

This law, though more or less suspected for a long time, was first formally enunciated and explained by Dove, and is known as *Dove's law of rotation of winds*.

1020. **Weather charts.**—A considerable advance has been made in weather forecasts by the frequent and systematic publication of *weather charts* that is to say, maps in which the barometric pressure, the tempe-

ature, the force of the wind, &c., are expressed for considerable areas in an exact and comprehensive manner. A careful study of such maps renders possible a forecast of the weather for a day or more in advance. We can here do no more than explain the meaning of the principal terms in use.

If lines are drawn through those places on the earth's surface where the corrected barometric height at a given time is the same, such lines are called *isobarometric lines*, or, more briefly, *isobaric lines* or *isobars*. Between any two points on the same isobar there is no difference of pressure. Isobars are usually drawn for a difference of 2.5 mm. or of $\frac{1}{10}$ of an inch.

If we take a horizontal line between two isobars, and at that point at which the pressure is greatest draw a perpendicular line on any suitable scale, which shall represent the *difference* in pressure between the two places, the line drawn from the top of this perpendicular to the lower isobar will form an angle with the horizontal, and the steepness of this angle is a measure of the fall in pressure between the two stations, and is called the *barometric gradient*. Gradients are usually expressed in England and America in hundredths of an inch of mercury for one degree of sixty nautical miles, and on the Continent in millimetres for the same distance. The closer are the isobars the steeper is the gradient, and the more powerful the wind; and though no exact numerical relationship can be proved to exist between the steepness of the gradient and the force of the wind, it may be taken that a gradient of about 6 represents a strong breeze; and a gradient of 10, or a difference in pressure of $\frac{1}{10}$ of an inch, for 60 miles, is a stiff gale.

The direction of the wind is from the place of higher pressure to that of lower, and in this respect the law of Buys Ballot may be mentioned, which has been found to hold in all cases of the Northern Hemisphere, where local configuration does not come into play. *If we stand with our back to the wind, the line of lower pressure is on the left hand.* For places in the Southern Hemisphere exactly the opposite law holds.

If within any area the pressure is lower, the wind blows round that area, the place of lowest pressure being on the left of the observer, standing with his back to the wind. The direction of the wind is, in short, contrary to that of the hands of a watch. Such a circulation is called *cyclonic*; it is that which is characteristic of the West Indian hurricanes, which are known as *cyclones*. Conversely, the wind blows round an area of higher pressure in the same direction as the hands of a watch; and this circulation is called *anti-cyclonic*.

Cyclonic systems are by far the most frequent, and are characterised by steep gradients; the air in them tends to move in towards the centre, and thence to the upper regions of the atmosphere. They bring with them over the greater part of the region which they cover much moisture, an abundance of cloud, and heavy rain. An anti-cyclonic system has the opposite characteristics: the gradients are slight, the wind is light, and moves with the hands of a watch. The air is dry, so that there is but little cloud, and no rain. Cyclonic systems, from the dampness of the air, produce warm weather in winter, and cold wet weather in summer. Anti-cyclonic systems bring our hardest frosts in winter and greatest heat in summer, as there is but little moisture in the air to temper the extremes of climate. Both systems travel

over the earth's surface—the cyclones rapidly, but the anti-cyclones more slowly.

1021. **Fogs and mists.**—When aqueous vapour rising from a vessel of boiling water diffuses in the colder air, it is condensed; a sort of cloud is formed, consisting of a number of small particles of water, which remain apparently suspended in the air. These are usually spoken of as vapour, yet they are not so—at any rate, not in the physical sense of the word, for in reality they are condensed vapour.

When this condensation of aqueous vapour is not occasioned by contact with cold solid bodies, but takes place throughout large spaces of the atmosphere, it constitutes *fogs* or *mists*, which, in fact, are essentially the same as the appearance seen over a vessel of hot water.

A chief cause of fogs consists in the moist soil being at a higher temperature than the air. The vapours which then ascend condense and become visible. In all cases, however, the air must have reached its point of saturation before condensation takes place. Fogs may also be produced when a current of hot and moist air passes over a river at a lower temperature than its own; for then, the air being cooled as soon as it is saturated, the excess of vapour present is condensed. The distinction between mists and fogs is one of degree rather than of kind. A fog is a very thick mist.

By observations based on diffraction phenomena (660), the diameter of fog particles has been found to vary from 0·0154 to 0·0521 mm.; the longer the continuance of fine weather, the smaller are the particles; before rains they increase rapidly.

Dines, by direct microscopic measurement, found that the diameter of fog particles varied with the same fog from 0·015 to 0·127 mm.; the larger occur in dense fogs, in lighter fogs they sink to 0·0033. Kämtz found from 0·014 to 0·035 mm.

When water is coated with a layer of coal-tar, it is prevented from evaporating. Frankland ascribed the *dry fog* met with in London to the large quantities of coal-tar and paraffin vapour which are sent into the atmosphere, and which, condensing on the particles of fog, prevent their evaporation.

Aitkin has shown that aqueous vapour never, under ordinary conditions, condenses unless some liquid or solid is present on which it is deposited. Particles of dust in the air are the nuclei for clouds and fogs. This he showed by passing steam into filtered air; it remained quite clear, while a turbidity was produced under the same circumstances in unfiltered air. The density of the cloud was found to depend on the number of particles of dust in the air. A most abundant source of dust is the combustion of coal. The sulphur in the coal in burning also forms sulphurous acid, which, though a gas, is found to act as a nucleus.

It has been shown by C. T. R. Wilson that gaseous ions (982) serve as nuclei on which aqueous vapour will condense. In the upper regions of the atmosphere the air is probably always ionised to some extent, and thus, even where there is no dust or foreign matter of any kind, condensation of aqueous vapour into droplets becomes intelligible.

1022. **Clouds.**—*Clouds* are masses of vapour condensed into little drops or particles of extreme minuteness, like fogs. There is no difference of kind

between fogs and clouds. Fogs are clouds resting on the ground. To a person enveloped in it, a cloud on a mountain appears like a fog. They always result from the condensation of vapour which rises from the earth. The horizontal base of a cloud denotes a layer of air in which the ascending current of air has attained the dew-point. According to their appearance clouds were divided by Howard into four principal kinds: the *nimbus*, the *stratus*, the *cumulus*, and the *cirrus*. These four kinds are represented in fig. 1038, and are designated respectively by one, two, three, and four birds on the wing.

The *cirrus* consists of small whitish clouds, which have a fibrous or wispy appearance, and occupy the highest regions of the atmosphere. The name of *mares' tails*, by which they are generally known, well describes



Fig. 1038

their appearance. From the low temperature of the spaces which they occupy, it is certain that cirrus clouds consist of frozen particles; and hence it is that halos, coronæ, and other optical appearances, produced by refraction and reflection from ice-crystals, appear almost always in these clouds and their derivatives. Their appearance often precedes a change of weather.

The *cumulus* are rounded spherical forms which look like mountains of cotton wool piled one on the other. They are more frequent in summer than in winter, and after being formed in the morning, they generally disappear towards evening. If, on the contrary, they become more numerous and especially if surmounted by cirrus clouds, rain or storms may be expected. Any such cumulus is nothing more than an ascending current of air which makes its path visible by condensed aqueous vapour.

Stratus clouds consist of very large and continuous horizontal sheets, which form chiefly at sunset and disappear at sunrise. They are frequent in autumn and unusual in spring-time, and are lower than the preceding.

The *nimbus* or rain clouds, which are sometimes classed as one of the fundamental varieties, are properly a combination of the three preceding kinds. They affect no particular form, and are solely distinguished by a uniform grey tint and by fringed edges. They are indicated on the right of the figure by the presence of one bird.

The fundamental forms pass into one another in the most varied manner. Howard classed these transitional forms as *cirro-cumulus*, *cirro-stratus*, and *cumulo-stratus*, and it is often very difficult to tell, from the appearance of a cloud, which type it most resembles. The *cirro-cumulus* is most characteristically known as a 'mackerel sky'; it consists of small roundish masses, disposed with more or less irregularity. It is frequent in summer, and attendant on warm and dry weather. *Cirro-stratus* appears to result from the subsidence of the fibres of cirrus to a horizontal position, which at the same time approach laterally. The form and relative position when seen in the distance frequently give the idea of shoals of fish. The tendency of *cumulo-stratus* is to spread, settle down into the *nimbus*, and finally fall as rain.

The height of clouds varies greatly; in the mean it is from 1300 to 1500 yards in winter, and from 3300 to 4300 yards in summer. But clouds often exist at greater heights; Gay-Lussac in his balloon ascent, at a height of 7630 yards, observed cirrus clouds above him, which appeared to be at a considerable height. In Ethiopia, D'Abbadie observed storm-clouds whose height was only 230 yards above the ground.

In order to explain the suspension of clouds in the atmosphere, Halley first proposed the hypothesis of vesicular vapours. He supposed that clouds are formed of an infinity of extremely minute vesicles, hollow, like soap-bubbles filled with air, which are hotter than the surrounding air, so that these vesicles float in the air like so many small balloons. Others assume that clouds and fogs consist of extremely minute droplets of water, which are retained in the atmosphere by the ascensional force of currents of hot air, just as light powders are raised by the wind. Ordinarily, clouds do not appear to descend, but this absence of downward motion is only apparent. In fact, clouds do usually fall slowly, but then the lower part is continually dissipated on coming in contact with the lower and more heated layers; at the same time the upper part is always increasing from the condensation of new vapours, so that from these two actions clouds appear to retain the same height. It must be remembered also that the viscosity of the air opposes the fall of the particles of a cloud. Stokes showed that the force resisting motion depends not only on the viscosity but also on the velocity of the water particles, and that its value is $6\pi\eta av$, where η is the coefficient of viscosity (450), a the radius of a drop, and v its velocity. Hence clouds descend with *uniform* velocity which varies with the square of the diameter of the water particles.

1023. **Formation of clouds.**—Many causes may concur in the formation of clouds. The usual cause of the formation of a cloud is the ascent, into higher regions of the atmosphere, of air laden with aqueous vapour; it

thereby expands, being under diminished pressure ; and in consequence of this expansion it is cooled, and cooling produces a condensation of vapour. Hence it is that high mountains, stopping the currents of air and forcing them to rise, are an abundant source of rain. If the air is quite dry, its temperature would be one degree lower for every 300 metres. The case is different with moist air ; for when the air has ascended so high that its temperature has fallen to the dew-point, aqueous vapour is condensed, and in consequence of this heat is liberated ; when the dew-point is thus attained, and the air is saturated, the cooling due to the ascent and expansion of air is counteracted by this liberation of latent heat, so that the diminution of temperature with the height is considerably slower in the case of moist than of dry air. About one-half of the entire quantity of moisture in the air is contained in the first six or seven thousand feet upon the ground.

The following calculation will give us the quantity of water separated in a given case : Suppose air at a temperature of 20° to be saturated with aqueous vapour at that temperature ; the pressure of the vapour will be 17.4 mm., and the weight contained in one cubic metre of air 17.1 grammes.

If the air has risen to a height of 3500 metres, the pressure to which it is subjected is reduced to $\frac{2}{3}$ of its original value ; the temperature of the air is now 4° C., and its volume about $1\frac{1}{2}$ times what it originally was. As it remains saturated the pressure will be 6.1 mm., and the quantity of vapour will be 6.4 grammes in a cubic metre—that is to say, $6.4 \times 1\frac{1}{2} = 9.6$ grammes in the whole mass of what was originally a cubic metre. The pressure of aqueous vapour has sunk during the ascent from 17.4 mm. to 6.1 mm., and its weight from 17.1 grammes to 9.6 grammes ; that is, a weight of 7.5 grammes has been deposited from the mass of air which at the sea-level occupied a space of one cubic metre. These 7.5 grammes are in the form of the small droplets which constitute fogs or clouds.

If the mass of air has risen to a height of 8500 metres, where the pressure is only one-third that on the sea-level, the temperature is -28° , and the space it occupies three times as great as at first. The pressure of aqueous vapour is 0.5 mm., and its weight 0.6 gramme per cubic metre. Hence there is now only 1.8 gramme left of the entire quantity of aqueous vapour originally present, and the remaining 15.3 grammes would be separated as water or ice. A similar calculation will show that at a height of 4200 metres, where the temperature is zero and the pressure $\frac{2}{3}$, the quantity of water present in the original cubic metre is only 0.82 gramme, the rest being deposited.

Thus, a mass of air which, at the sea-level, occupies a space of a cubic metre, and is saturated with aqueous vapour at 20° , and then contains 17.1 grammes, will contain only 9.6 grammes at a height of 3500 metres, 8.2 grammes at 4200 metres, and 1.8 gramme at 8500 metres. Hence, while a mass of air rises from the sea-level to a height of 4200 feet, 8.9 grammes of aqueous vapour are separated as cloud-particles ; at 8500 metres, or about double the height, 6.4 grammes are separated in the form of ice.

A hot moist current of air mixing with a colder current undergoes a cooling, which brings about a condensation of the vapour. Thus, the hot and moist winds of the south and south-west, mixing with the colder air of our latitudes, give rain. The winds of the north and north-east tend also,

in mixing with our atmosphere, to condense the vapours ; but as these winds, owing to their low temperature, are very dry, the mixture rarely attains saturation, and generally gives no rain.

The formation of clouds in this way is thus explained by Hutton. The pressure of aqueous vapour, and therewith the quantity present in a given space when saturated, diminishes according to a geometrical progression, while the temperature falls in arithmetical progression, and therefore the elasticity of the vapour present at any time is reduced by a fall of temperature more rapidly than in direct proportion to the fall. Hence, if a current of warm air, saturated with aqueous vapour, meets a current of cold air also saturated, the air acquires the mean temperature of the two, but can retain only a portion of the vapour in the invisible condition, and a cloud or mist is formed. Thus, suppose a cubic metre of air at 10° C. mixes with a cubic metre of air at 20° C., and that they are respectively saturated with aqueous vapour. By formula (407) it is easily calculated that the weight of water contained in the cubic metre of air at 10° C. is 9.397 grammes, and in that at 20° C. is 17.153 grammes, or 26.559 grammes in all. When mixed they produce two cubic metres of air at 15° C. ; but as the weight of water required to saturate this is only $2 \times 12.8 = 25.6$ grammes, the excess, 0.95 gramme, will be deposited in the form of mist or clouds.

1024. *Rain.*—When the individual water-particles become larger and heavier by the condensation of aqueous vapour, and when, finally, individual particles unite, they form regular drops, which fall as *rain*.

The quantity of rain which falls annually in any given place, or the annual rainfall, is measured by means of a *rain-gauge*, or *pluviometer*.

Ordinarily it consists of a cylindrical vessel, M (figs. 1039 and 1040), closed at the top by a funnel-shaped lid, in which there is a very small hole, through which the rain falls. At the bottom of the vessel is a glass tube, A, in which the water rises to the same height as inside the rain-gauge, and is measured by a scale on the side, as shown in the figures.

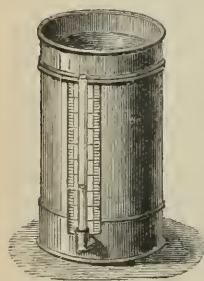

Fig. 1039

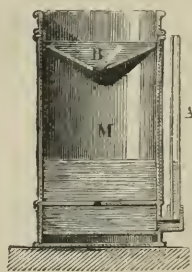

Fig. 1040

The apparatus being placed in an exposed situation, if at the end of a month the height of water in the tube is two inches, for example, it shows that the water has attained this height in the vessel, and, consequently, that a layer of two inches in depth expresses the quantity of rain which this extent of surface has received.

It has been noticed that the quantity of rain indicated by the rain-gauge is greater the nearer this instrument is to the ground. This has been ascribed to the fact that the raindrops, which are generally colder than the layers of air which they traverse, condense the vapour in these layers, and therefore constantly increase in volume. Hence more rain falls on the surface of the ground than at a certain height. But it has been objected that the excess

of the quantity of rain which falls, over that at a certain height, is six or seven times that which could arise from condensation, even during the whole course of the raindrops from the clouds to the earth. The difference must therefore be ascribed to purely local causes, and it is now assumed that the difference arises from eddies produced in the air about the rain-gauge, which are more perceptible the higher it is above the ground : as these eddies disperse the drops which would otherwise fall into the instrument, they diminish the quantity of water which it receives.

In any case it is clear that, if raindrops traverse moist air, they will, from their lower temperature, condense aqueous vapour and increase in volume. If, on the contrary, they traverse dry air, the drops tend to vaporise, and less rain falls than at a certain height ; it might even happen that the rain did not reach the earth.

From measurements of the coronæ (1022), Delezenne determined the diameter of the globules in the case of rain-clouds just about to fall, and in the case of the cloud from a low-pressure steam-engine (474). The former was found to vary from 0·0565 to 0·0226 mm., and the latter from 0·0051 to 0·0042 mm. With the former, 5500 droplets would be needed to make a drop of water a millimetre in diameter, and with the latter 50,000.

According to the same author, there would be about 15 mgr. of globules in a cubic metre of a cloud which produced a rainfall of 10 mm. of water in an hour. With this number the mean distances of the particles with the above magnitudes are respectively 1·845, 0·706, 0·167, and 0·148 mm.

Many local circumstances may affect the quantity of rain which falls in different countries ; but, other things being equal, most rain falls in hot climates, for there the vaporisation is most abundant. The rainfall decreases, in fact, from the equator to the poles. At London it is 23·5 inches ; at Bordeaux it is 25·8 ; at Madeira it is 27·7 ; at Havannah it is 91·2 ; and at St. Domingo it is 107·6. The quantity varies with the season : in Paris, in winter, it is 4·2 inches ; in spring, 6·9 ; in summer, 6·3 ; and in autumn, 4·8 inches. The heaviest annual rainfall at any place on the globe is on the Khasi Hills, in Bengal, where it is 600 inches ; of which 500 inches fall in seven months. On July 1, 1851, a rainfall of 25½ inches on one day was observed at Cherrapoonjee. At Kurrachee, in the north-west of India, the rainfall is only 7 inches.

The rainfall diminishes with the height of a station above the sea-level at the rate of 3 or 4 per cent. for each 100 feet of altitude above the sea.

The driest recorded place in England is Lincoln, where the mean rainfall is 20 inches ; and the wettest is Stye, at the head of Borrowdale, in Cumberland, where it amounts to 165 inches. The greatest average amount of rainfall in any one day, taking the means of all stations, is 1½ inch ; though individual stations far exceed this amount, sometimes reaching 4 inches.

An inch of rain on a square yard of surface expresses a fall of 46·74 pounds, or 4·67 gallons. On an acre it corresponds to 22,622 gallons, or 100·9935 tons. 100 tons *per inch per acre* is a ready way of remembering this.

1025. **Waterspouts.**—On hot summer days, and when the weather is otherwise calm, we often notice sand and dust carried forward in a column with a whirling motion. As storms come on, larger whirlwinds of this kind

are formed, which carry with them leaves, straw, and even small branches. When they are of larger dimensions they form real whirlwinds. They are probably due to the contact of two winds blowing in the upper regions of the atmosphere. When they pass over land they form large conical-shaped masses of dust, which make them visible at a distance; when they pass over rivers or the sea they present a curious phenomenon: the water is disturbed, and rises in the form of a cone, while the clouds are depressed in the form of an inverted cone; the two cones then unite and form a continuous column from the sea to the clouds (fig. 1041). Even, however, on the high seas the water of these waterspouts is never salt, proving that they are formed of condensed vapour, and not of sea-water raised by aspiration.

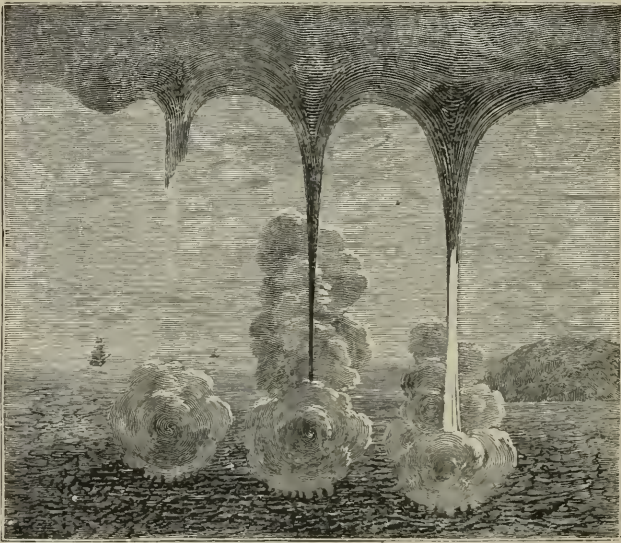

Fig. 1041

1026. Influence of aqueous vapour on climate.—Tyndall applied the property possessed by aqueous vapour of powerfully absorbing and radiating heat to the explanation of some obscure points in meteorology. He established the fact that in a tube 4 feet long the atmospheric vapour on a day of average dryness absorbs 10 per cent. of obscure heat. With the earth warmed by the sun as a source, at the very least 10 per cent. of its heat is intercepted within 10 feet of the surface. The absorption and radiation of aqueous vapour is more than 16,000 times that possessed by dry air.

The *radiative* power of aqueous vapour may be the main cause of the torrent-like rains that occur in the tropics, and also of the formation of cumulus clouds in our own latitudes. The same property probably causes the descent of very fine rain, called *serain*, which has more the characteristics of falling dew, as it appears a short time after sunset, when the sky is clear;

its production has therefore been attributed to the cold resulting from the radiation of the air. It is not the air, however, but the aqueous vapour in the air, which by its own radiation chills itself, so that it condenses into *sérein*.

The *absorbent* power of aqueous vapour is of even greater importance. Whenever the air is dry, terrestrial radiation at night is so rapid as to cause intense cold. Thus in the central parts of Asia, Africa, and Australia, the daily range of the thermometer is enormous; in the interior of the last-named continent a difference in temperature of no less than 40° C. has been recorded within 24 hours. In India, and even in the Sahara, ice has been formed at night, owing to the copious radiation. But the radiation which aqueous vapour absorbs most largely is of the kind emitted from sources of low temperature; it is to a large extent transparent to the short waves emitted by the sun, whilst it is almost opaque to the heat radiated from the earth. Consequently the solar rays penetrate our atmosphere with a loss, as estimated by Pouillet, of only 25 per cent., when directed vertically downwards, but after warming the earth they cannot retrace the atmosphere. Through thus preventing the escape of terrestrial heat, the aqueous vapour in the air moderates the extreme chilling which is due to the unchecked radiation from the earth, and raises the temperature of that region over which it is spread. In Tyndall's words, 'aqueous vapour is a blanket more necessary to the vegetable life of England than clothing is to man. Remove for a single summer night the aqueous vapour from the air which overspreads this country, and every plant capable of being destroyed by a freezing temperature would perish. The warmth of our fields and gardens would pour itself unrequited into space, and the sun would rise upon an island held fast in the iron grip of frost.'

1027. **Tyndall's researches.**—Tyndall found that the action of the sun or of the electric light decomposed certain highly rarefied vapours. He used a glass tube, which could be exhausted and then filled with air charged with the vapours of volatile liquids, by allowing the air to bubble through small Wolff bottles containing them. The tube having been filled with air charged with vapour of amyl nitrite at a definite pressure, a somewhat convergent beam of sunlight or of the radiation from an electric arc was passed into the tube. For a moment the tube appeared optically empty, but suddenly a shower of liquid spherules was precipitated on the path of the beam, forming a luminous white cloud. It was shown that the effect was not due to chemical action between the vapour and the air, nor to heating action, but was the result of the action of the more refrangible constituents of the incident radiation. When the incident beam, before entering the experimental tube, was made to pass through a layer of liquid amyl nitrite an eighth of an inch in thickness, the luminous effect was not appreciably diminished, but the chemical action was almost entirely stopped. Thus, that special constituent of the luminous radiation which effects the decomposition of the vapour is absorbed by the liquid. The decomposition of liquid amyl nitrite by light, if it takes place at all, is far less rapid and distinct than that of the vapour. The absorption in the same, whether the nitrite is in the liquid or in the vaporous state, showing that it is not the act of the molecule as a whole, but that it is atomic; that is, that it is to the

atoms that the peculiar rate of vibration is transferred which brings about the decomposition of the body.

In cases where the vapours are under a sufficient degree of attenuation, whatever otherwise be their nature, the visible action commences with the formation of a *blue cloud*. The term 'cloud,' however, must not be understood in its ordinary sense; the blue cloud is invisible in ordinary daylight, and to be seen must be surrounded by darkness, *it alone* being illuminated by a powerful beam of light. The blue cloud differs in many important particulars from the finest ordinary clouds, and may be considered to occupy an intermediate position between these clouds and true cloudless vapour.

By graduating the quantity of vapour, the precipitation may be obtained of any required degree of fineness; forming either particles distinguishable by the naked eye, or particles beyond the reach of the highest microscopic power. The case is similar to that of carbonic acid gas, which, diffused in the atmosphere, resists the decomposing action of solar light, but is decomposed when in contact with the chlorophyll in the leaves of plants.

When the blue cloud produced in these experiments was examined by any polarising arrangement, the light emitted laterally from the beam—that is, in the direction at right angles to its axis—was found to be perfectly polarised. This phenomenon was observed in its greatest perfection the more perfect the blue of the cloud. It is produced by any particles, provided they are sufficiently fine. This is quite analogous to the light of the blue sky. When this is examined by a Nicol prism, or any other analyser, it is found that the light emitted at right angles to the path of the sun's rays is polarised.

Tyndall's experiments illustrate, though they do not explain, the blue colour of the sky. A more complete explanation was suggested by Lord Rayleigh in 1871. Assuming the existence of any small particles in the upper regions of the atmosphere, these will impede to a greater or less extent the passage of radiant waves which fall upon them, and, for particles of a given size, short waves will be more obstructed than longer ones. In other words, when radiation passes through a medium containing small particles the longer waves will be more freely transmitted than those of higher refrangibility. Hence, white light, after passing through such a medium, would appear yellowish or even reddish if the thickness were sufficient, and on the other hand the rays reflected or scattered by the small particles would have a blue or violet tint. It must be remembered, however, that the sunlight which reaches us from any point of the sky has lost some of its constituents at both ends of the spectrum; by transmission it has lost some of the shortest waves, and by reflection and scattering by small particles it has been deprived of waves at the lower end of the spectrum. In other words, it will be compounded of waves of intermediate length, and will appear blue or blue-green, the exact colour depending on the size and closeness together of the particles.

1028. **Dew. Hoarfrost.**—*Dew* is aqueous vapour which has condensed on bodies during the night in the form of minute globules. It is occasioned by the chilling which bodies near the surface of the earth experience in consequence of nocturnal radiation. Their temperature having then sunk several degrees below that of the air, it frequently happens, especially in hot

seasons, that this temperature is below that at which the atmosphere is saturated. The layer of air which is immediately in contact with the chilled bodies, and which has virtually the same temperature, then deposits a portion of the vapour which it contains (400); just as when a bottle of cold water is brought into a warm room it becomes covered with moisture, owing to the condensation of aqueous vapour upon it.

According to this theory, which was first propounded by Dr. Wells, all causes which promote the cooling of bodies increase the quantity of dew. These causes are the emissive power of bodies, the state of the sky, and the agitation of the air. Bodies which have a great radiating power more readily become cool, and therefore ought to condense more vapour. In fact there is generally no deposit of dew on metals, whose radiating power is very small, especially when they are polished; while the ground, sand, glass, and plants, which have a great radiating power, become abundantly covered with dew.

The state of the sky also exercises a great influence on the formation of dew. If the sky is cloudless, the planetary spaces send to the earth an inappreciable quantity of heat, while the earth radiates very considerably, and therefore, becoming very much chilled, there is an abundant deposit of dew. But if there are clouds, as their temperature is far higher than that of the planetary surfaces, they radiate in turn towards the earth, and as bodies on the surface of the earth experience only a feeble chilling, no deposit of dew takes place.

Wind also influences the quantity of vapour deposited. A gentle breeze increases the deposition, since it renews the air; the contrary effect is produced by a strong wind, which heats the surface by contact, and thus does not allow the air time to become cooled. Finally the deposit of dew is more abundant according as the air is moister, for then it is nearer its point of saturation.

Hoarfrost and *rime* are dew which has been deposited on bodies cooled below zero, and has become frozen. The flocculent form which the small crystals present of which rime is formed, shows that the vapour solidifies directly without passing through the liquid state. Hoarfrost, like dew, is formed on bodies which radiate most, such as the stalks and leaves of vegetables, and is chiefly deposited on the parts turned towards the sky.

We must distinguish between the dew formed in consequence of lowering of temperature by radiation, and the deposit formed by warm moist air passing over a cold wall; in mild weather this deposit forms a liquid, and in severe weather a snow or icy coating. Unlike dew a deposit of this kind is most abundantly found on good conductors, for they are the coldest.

1029. **Snow. Sleet.**—*Snow* is water solidified in stellate crystals, variously modified, and floating in the atmosphere. These crystals arise from the congelation of the minute particles which constitute the clouds, when the temperature of the latter is below zero. They are more regular when formed in a calm atmosphere. Their form may be investigated when they are collected on a black surface and viewed through a strong lens. The regularity, and at the same time variety, of their forms are truly beautiful. Fig. 1042 shows some of these forms as seen through a microscope. Very roughly, a fall of one foot of snow may be taken as equal to an inch of rain.

It snows most in countries near the poles, or lying high above the sea-level. By the limit of perpetual snow—or, briefly, *snow-line*—is meant that height above the sea-level at which the snow does not melt, even in the hottest summers. It is lower nearer the poles than the equator: it does not depend solely on the latitude, but is influenced by many local circumstances.

Sleet is also solidified water, and consists of small icy needles pressed together in a confused manner. Its formation is ascribed to the sudden congelation of the minute globules of the clouds in an agitated atmosphere.

When the ground is cooled below zero after severe frost and a thaw sets in, the moist air passing over the ground deposits its moisture, which is

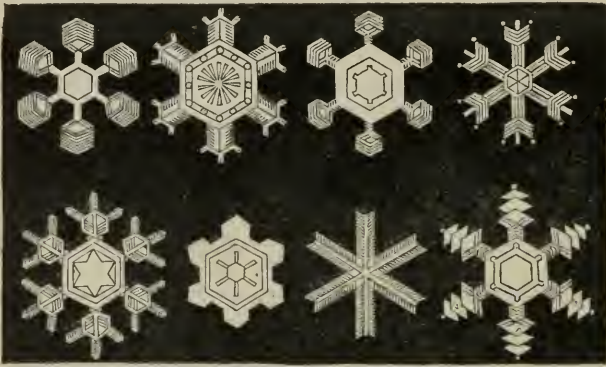

Fig. 1042

converted into a continuous sheet of ice; this is known as *glazed frost* (the French *verglas*); it may also occur when raindrops which have been cooled below zero in the higher regions of the air, and are accordingly in a state of superfusion (348), fall on the ground, which may even be above the freezing-point.

1030. **Hail.**—*Hail* is a mass of compact globules of ice of different sizes which fall in the atmosphere. In our climate hail falls principally during spring and summer, and at the hottest times of the day; it rarely falls at night. The fall of hail is always preceded by a peculiar noise.

Hail is generally the precursor of storms; it rarely accompanies them, and follows them still more rarely. Hail falls from the size of a small pea to that of an egg or an orange, with a core of compressed snow which is surrounded by concentric layers of ice. While snowstorms may last for days, hailstorms do not last for more than a quarter of an hour. The formation of hailstones has never been altogether satisfactorily accounted for; nor, more especially, their great size.

1031. **Ice. Regelation.**—Ice is an aggregation of snow-crystals, such as are shown in fig. 1042. The transparency of ice is due to the close contact of these crystals, which causes the individual particles to blend into an unbroken mass, and renders the substance *optically*, as well as mechanically,

continuous. When large masses of ice slowly melt away, a crystalline form is sometimes seen by the gradual disintegration into rude hexagonal prisms ; a similar structure is frequently met with, but in greater perfection, in the ice-caves or glaciers of cold regions.

An experiment of Tyndall shows the beautiful structure of ice. When a piece of ice is cut parallel to its planes of freezing, and the radiation from any source of light is permitted to pass through it, the disintegration of the substance proceeds in a remarkable way. By observing the plate of ice through a lens, numerous small crystals will be seen studding the interior of the block ; as the heat continues these crystals expand, and finally assume the shape of six-rayed stars of exquisite beauty.

This is a kind of negative crystallisation, the crystals produced being composed of water ; they owe their formation to the molecular disturbance caused by the absorption of heat from the source. Nothing is easier than to reproduce this phenomenon, if care is taken in cutting the ice. The planes of freezing can be found by noting the direction of the bubbles in ice, which are either sparsely arranged in striæ at right angles to the surface, or thickly collected in beds parallel to the surface of the water. A warm and smooth metal plate should be used to level and reduce the ice to a slab not exceeding half an inch in thickness.

A still more important property of ice remains to be noticed. Faraday discovered that when two pieces of melting ice are pressed together they freeze into one at their points of contact. This curious phenomenon is now known under the name of *Regelation*. The cause of it has been the subject of much controversy ; Faraday's explanation is as follows :—The particles on the exterior of a block of ice are held by cohesion on one side only : when the temperature is at 0° C., these exterior particles, being partly free, are the first to pass into the liquid state, and a film of water covers the solid. But the particles in the interior of the block are bounded on all sides by the solid ice, the force of cohesion is here a maximum, and hence the interior ice has no tendency to pass into a liquid, even when the whole mass is at 0° . If the block is now split in halves, a liquid film instantly covers the fractured surfaces, for the force of cohesion on the fractured surfaces has been lessened by the act. By placing the halves together, so that their original position shall be regained, the liquid films on the two fractured surfaces again become bounded by ice on both sides. The film being excessively thin, the force of cohesion is able to act across it ; the consequence of this is, the liquid particles pass back into the solid state, and the block is reunited by *regelation*.

A more satisfactory explanation is that which refers the phenomenon to the lowering of the freezing-point of water by pressure (342). Two pieces of ice at 0° C. will not melt, if they are prevented from absorbing heat. When pressed together at 0° , since the melting-point is lowered, an incipient liquefaction takes place at the surfaces of contact, and when the pressure is relaxed, the freezing-point rises and the two pieces are frozen together. The formation of a snowball is explained in the same way. At temperatures below 0° C. a snowball cannot be made ; the snow is dry and the pressure of the hands is not sufficient to lower the melting-point necessary to produce regelation.

The snow-bridges, also, which span wide chasms in the Alps and elsewhere, and over which men can walk in safety, owe their existence to the regelation of gradually accumulating particles of snow.

We see an example of this formation of ice from pressure in the glazed appearance of the tracks in snow on roads over which heavy carts have passed.

Bottomley has made a very instructive experiment which illustrates the effect of pressure on regelation. A block of ice is suspended on two supports, and a hempen string with heavy weights at each end is laid across it. After some time the string has slowly cut its way through, but the cut surfaces have reunited, and, excepting a few bubbles, show no trace of the operation. If a metallic wire is used instead of the string, the action is accelerated owing to the heat conducted along the wire from the outside.

1032. **Glaciers.**—Tyndall applied this regelating property of ice to an explanation of the formation and motion of glaciers, of which the following is a brief description :—In elevated regions, the *snow-line* (1029) marks the boundary of eternal snow, for above this the heat of summer is unable to melt the winter's snow. By the heat of the sun and the consequent percolation of water melted from the surface, the lower portions of the snow-field are raised to 0° C. ; at the same time this part is closely pressed together by the weight of the snow above ; regelation therefore sets in, converting the loose snow into a coherent mass.

By increasing pressure, the intermingled air which renders snow opaque is ejected and the snow becomes transparent ; ice is then formed. Its own weight and the pressure from behind urge downwards the glacier which has thus been formed. In its descent the glacier behaves like a river, passing through narrow gorges with a certain velocity, and then spreading out and moving more slowly as its bed widens. Further, just as the central portions of a river move faster than the sides, so Forbes ascertained that the centre of a glacier moves more quickly than its margin, and from the same reason (the difference in the friction encountered) the surface moves more rapidly than the bottom. To explain these facts Forbes assumed ice to be a viscous body capable of flexure, and flowing like lava ; but as ice has not the properties of a viscous substance, the now generally accepted explanation of glacier motion is that supplied by the theory of regelation. According to this theory, the brittle ice of the glacier is crushed and broken through narrow channels, and partially melted owing to the increased pressure, and then, as it emerges from the gorge which confined it, the pressure is relieved and the liquefied portion again freezes and becomes united by virtue of regelation. By numerous experiments Tyndall artificially imitated, on a small scale, the moulding of glaciers by the crushing and subsequent regelation of ice.

1033. **Atmospheric electricity. Franklin's experiment.**—The most frequent luminous phenomena, and the most remarkable for their effects, are those produced by the free electricity in the atmosphere. The first physicists who observed the electric spark compared it to the gleam of lightning, and its crackling to the sound of thunder. But Franklin, by the aid of powerful Leyden batteries, first established a complete parallelism between lightning and electricity ; and indicated, in a memoir published in 1749, the experiments necessary to attract electricity from the clouds by

means of pointed rods. The experiment was tried by Dalibard in France ; and Franklin, pending the erection of a pointed rod on a spire in Philadelphia, had the happy idea of flying a kite, provided with a metal point, which could reach the higher regions of the atmosphere. In June, 1752, during stormy weather, he flew the kite in a field near Philadelphia. The kite was flown with ordinary packthread, at the end of which Franklin attached a key, and to the key a silk cord, in order to insulate the apparatus ; he then fixed the silk cord to a tree, and having presented his hand to the key, at first he obtained no spark. He was beginning to despair of success, when, rain having fallen, the cord became a good conductor, and a spark passed. Franklin, in his letters, describes his emotion on witnessing the success of the experiment as being so great that he could not refrain from tears.

Franklin imagined that the kite drew from the cloud its electricity ; it is, in fact, a simple case of induction, and depends on the inductive action which the thunder-cloud exerts upon the kite and the cord.

1034. **Apparatus to investigate the electricity of the atmosphere.**—To observe the electric potential in fine weather, an apparatus may be used as devised by Saussure for this kind of investigation. It is an electroscope similar to that already described (748), but the rod to which the gold leaves are fixed is surmounted by a conductor 2 feet in length, and terminates in either a knob or a point (fig. 1043). To protect the apparatus against rain, it is covered with a metal shield 4 inches in diameter. The glass case is square instead of being round, and a divided scale on its inside face indicates the divergence of the gold leaves. This electroscope gives signs of atmospheric electricity only as long as it is raised in the atmosphere so that its pointed end is in layers of air of different electric potential from its own.

To measure the potential of the atmosphere Saussure also used a copper ball, which he projected vertically with his hand. This ball was fixed to one end of a metal wire, the other end of which was attached to a ring, which could glide along the conductor of the electroscope. From the divergence of the gold leaves, the electric condition of the air at the height which the ball attained could be determined. Becquerel, in experiments made on the St. Bernard, improved Saussure's apparatus by substituting for the knob an arrow, which was projected into the atmosphere by means of a bow. A gilt silk thread, 38 yards long, was fixed with one end to the arrow, while the other end was attached to the stem of an electroscope.

To observe the electricity of clouds, where the potential may be very considerable, use is made of a long bar terminating in a point. This bar,

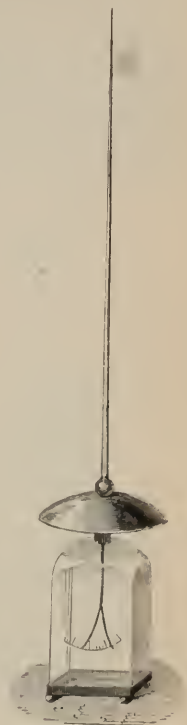

Fig. 1043

which is insulated with care, is fixed to the summit of a building, and its lower end is connected with an electrometer. Let the space round the point of the bar be at a positive potential, V . The bar, which we will suppose to be at zero potential, becomes charged by induction with negative at the point and positive at the lower end, so that the leaves of the electroscope diverge. Negative electricity is discharged from the point (780) until its potential is equal to that of the surrounding space. When equilibrium is established, the electroscope indicates the potential of the point and, therefore, of the space in its neighbourhood. If the potential of this space rises, the point discharges negative electricity and the leaves diverge wider; if the potential falls the point discharges positive electricity, and the divergence diminishes.

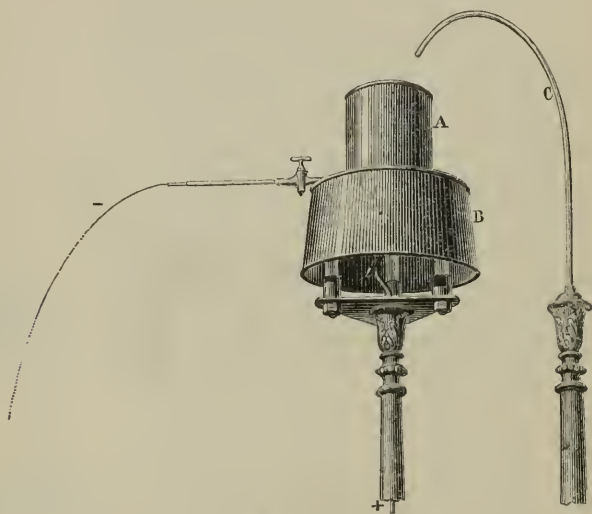

Fig. 1044

Thus the electroscope shows the changes in potential of the space round the point. In stormy weather the potential may be considerable, and as the bar can then give dangerous shocks, a metal ball must be placed near it which is well connected with the ground, and which is nearer the bar than the observer himself; so that if a discharge should ensue, it will strike the ball and not the observer. Richmann, of St. Petersburg, was killed in an experiment of this kind, by a discharge which struck him on the forehead.

In modern arrangements, the sharp point has been replaced by a burning match or by dropping water. A roll of nitrate of lead paper, looking something like a thin cigarette, is attached to the conductor, and when lighted smoulders slowly, producing a smoke which rapidly dissipates electricity and raises the potential of the conductor to that of the surrounding space.

A convenient instrument for investigating atmospheric electricity was introduced by Lord Kelvin, one form of which used in the Meteorological Observatory of Montsouris, is represented in fig. 1044. It consists of a large metal vessel, *A*, resting on three insulating brass legs fixed to the top

of a tall column of cast iron. A sheet-metal mantle, B, protects the supports from the rain. The apparatus is arranged in the open, and can be filled with water from a pipe, C. The water issues through a long lateral jet in A, in a stream so fine that the volume of the water is only slowly altered. An insulated wire, *i*, passing through the column, connects the vessel A with an electrometer placed indoors. This plan of collecting the atmospheric electricity is adopted in balloons, where a smouldering match is undesirable.

The manner in which the electricity of the atmosphere is registered is seen from fig. 1045, which represents the form in use at the Montsouris observatory.

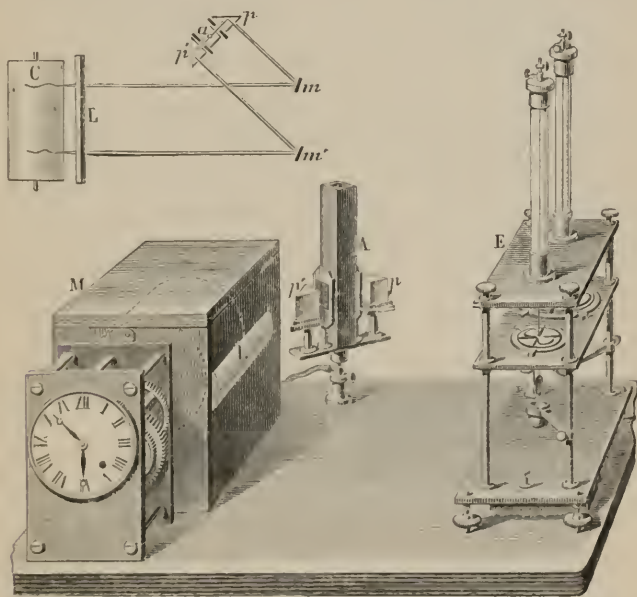

Fig. 1045

In a light-tight box is a band of sensitised photographic paper, stretched on the surface of a cylinder and moved by clockwork.

In one side of the box is a long cylindrical glass lens, L, in front of which at E are two quadrant electrometers (796). Both of these are connected with the same collector of electricity, placed outside, and their sectors are charged by the same source of electricity, but one of them is ten times as sensitive as the other. Near one side of the box is a gas-burner with an opaque chimney, A, in two opposite sides of which are longitudinal slits, through which the light passes to two total reflection prisms (550), *p p'*, which are arranged so as to send two pencils of light on the mirrors, *m m'*, of the electrometer. This is shown on a larger scale on the left of the figure: the two pencils fall upon the lens, L, which concentrates in a point the slices of light issuing from the chimney and reflected from the mirror. These follow

the motion of the mirror, and thus impress on the sensitive paper the curves of electric potential of the air. There is also an arrangement by which an electromagnet puts the electrometers to earth for a few minutes at every hour, and thus discharges them. The mirrors revert then to their original position and commence a new trace.

There are some objections to the use of the water-dropping apparatus. For example, the water freezes in severe weather, and accidental impurities in the water may choke the fine tube. Radium chloride (984) has recently been used as a collector of electricity with some success.

1035. **Ordinary electricity of the atmosphere.**—By means of the different apparatus which have been described, it has been found that the presence of electricity in the atmosphere is not confined to stormy weather, but that the atmosphere always contains free electricity, in the vast majority of cases positive, but occasionally negative. When the sky is unclouded the potential is always positive, and increases with the height above the ground. Its value is greatest in the highest and most isolated places. No trace of positive electricity is found in houses, streets, and under trees; in towns, positive electricity is most perceptible in large open spaces, on quays, or on bridges. Lord Kelvin found in the Isle of Arran, at a height of 9 feet above the ground, a difference of potential equal to 200 to 400 Daniell cells, or from 216 to 432 volts. This represents a rise of potential of from 24 to 48 volts for each foot of ascent. The potential at any point is subject to great variation; with winds from the north and north-east the potential was often six to ten times as much as the higher of these amounts. The change of potential is most rapid in cold dry weather, when the quantity of moisture in the air is at its lowest. Thus, at a temperature of -8° to -12° C., Exner found a change of 600 volts per metre in the direction of the vertical. With a vapour-pressure of 2.3 mm. the change was 325, with 6.8 it was 116, and with 12.5 it was 68.

Between 5 and 7.30 A.M. the positive electricity in the air is at a minimum; it increases from 7 to 9.30 A.M., according to the season, and then attains its first maximum. It then decreases rapidly until from 2.30 to 4.30 P.M., and again increases till it reaches its second maximum, from 6.30 to 9.30 P.M.; the remainder of the night the electricity decreases until sunrise. Thus the greatest amount of electricity is observed when the barometric pressure is highest. These increasing and decreasing periods, which are observed all the year, are more perceptible when the sky is clearer and the weather more settled. The positive electricity of fine weather is much stronger in winter than in summer. It may, in short, be said that electricity of the air follows the opposite course to that of temperature and moisture.

When the sky is clouded, the electricity is sometimes positive and sometimes negative. According to Palmieri, the occurrence of negative electricity is a certain indication that within a distance of 40 miles it either rains, or snows, or hails. It often happens that the electricity changes its sign several times in the course of the day, owing to the passage of an electrified cloud. During storms, and when it rains or snows, the atmosphere may be positively electrified one day, and negatively the next, and the numbers of the two sets of days are virtually equal.

During a thunderstorm the changes in potential and sign of electricity are so rapid that the photographic method of registration fails.

From a long series of observations on the electricity of the atmosphere made in the early morning, Dellman found that the electricity increased with the density of the fog, but in a far more rapid ratio.

The electricity of the ground was found by Peltier to be always negative, and this seems to be the cardinal fact in reference to atmospheric electricity ; it is so, however, to different extents, according to the hygrometric state and temperature of the air. The density is, moreover, exceedingly small, being calculated at 0·00036 unit per square centimetre, from which it follows that the electric pressure (757) is 0·0000008 dyne per square centimetre, or less than the millionth of a milligramme-weight. Even if the pressure were ten times as great, it would be insufficient to raise the lightest bodies.

1036. **Causes of atmospheric electricity.**—Although many hypotheses have been propounded to explain the origin of atmospheric electricity, it must be confessed that our knowledge is in an unsatisfactory state.

Volta first showed that the evaporation of water produced electricity. Pouillet subsequently showed that no electricity is produced by the evaporation of distilled water ; but that if an alkali or a salt is dissolved, even in small quantity, the vapour is positively and the solution is negatively electrified. The reverse is the case if the water contains acid. Hence it has been assumed, that as the waters which exist on the surface of the earth and on the sea always contain salt dissolved, the vapours disengaged ought to be positively and the earth negatively electrified. The development of electricity by evaporation may be observed by heating strongly a platinum dish, adding to it a small quantity of liquid, and placing it on the upper plate of the condensing electroscope (fig. 795), taking care to connect the lower plate with the ground. When the water of the capsule is evaporated, the connection with the ground is broken, and the upper plate raised. The gold leaves then diverge if the water contains salts, but remain quiescent if the water is pure.

Reasoning from such experiments, Pouillet ascribed the development of electricity by evaporation to the separation of particles of water from the substances dissolved ; but Reich and Riess showed that the electricity disengaged during evaporation could be attributed to the friction which the particles of water carried away in the current of vapour exert against the sides of the vessel, just as in Armstrong's hydro-electric machine (771). By a series of experiments, Gaugain arrived at the same result.

Sohncke recalls an experiment of Faraday which he has repeated, showing that the friction of minute particles of water against dry ice is an abundant source of electricity ; he ascribes atmospheric electricity to this origin, suggesting that in the upper regions particles of both water and ice may coexist. The ice particles become positively electrified, while those of water are negative. When these fall in rain, they carry with them their negative electricity. A similar theory has been propounded by Luvini.

1037. **Electricity of clouds.**—Clouds are in general electrified usually positively, but sometimes negatively, and differ only in their higher or lower potential. The formation of positive clouds is by some ascribed to

the vapour disengaged from the ground and condensed in the higher regions. Negative clouds are supposed to result from fogs, which, by their contact with the ground, become charged with negative electricity, which they retain on rising into the atmosphere; or to have been separated from the ground by layers of moist air, and negatively electrified by induction from the positive clouds, which have repelled into the ground positive electricity. Thunder-clouds are sometimes as low as 700 to 1000 feet; but their usual height appears to be 3000 to 6000 feet.

Whatever be the origin of atmospheric electricity, there can be no doubt that the invisible aqueous vapour is the carrier of it, and it is easy to explain the high potential of clouds from the condensation of this vapour. For suppose 1000 vapour-particles, each of the same size and possessing the same charge of electricity, coalesce to form a single droplet, the diameter of such a droplet will be ten times that of the individual particles—that is, its capacity is ten times as great, since the capacity is equal to the radius (760); but the quantity of electricity will be 1000 times as great as on the small one, and therefore the potential will be 100 times as great. Now the number of vapour-particles which go to form a single droplet is rather to be counted by billions; hence, however small be the finite value which we assign to the potential of the electricity of the vapour-particles, that of the drops will be enormously greater, and sufficient to account for the high potential of clouds.

1038. **Lightning.**—This, as is well known, is the dazzling light emitted by the electric spark when it shoots from clouds charged with electricity. In the lower regions of the atmosphere the light is white, but in the higher regions, where the air is more rarefied, it takes a somewhat reddish tint; as does the spark of the electric machine in a rarefied medium (803).

The flashes of lightning are often more than a mile, and sometimes extend to four or five miles, in length; they generally pass through the atmosphere in an irregular direction—a phenomenon ascribed to the resistance offered by the air condensed by the passage of a strong discharge. The spark then diverges from a right line, and takes the direction of least resistance. In a vacuum, electricity passes in a straight line.

We cannot, however, regard the length of a lightning flash as the direct striking distance between two conductors. Owing to the number of droplets met on its path, the discharge is rather to be compared with that of the luminous tubes and panes (785). The experiments of Mascart on the relation between the striking distance (805) and the potential required to produce it show that the striking distance increases far more rapidly than the potential. Thus, while the potential required for a striking distance of 1 cm. is represented by 8·3, for 4 cm. it is 15·9, for 8 cm. 20·5, and for 15 cm. 23·3. From this it is possible that a lightning discharge is produced by a difference of potentials between two clouds which is not greatly out of proportion with those obtained by our electric machines.

Several kinds of lightning flashes may be distinguished—1, the *zigzag* flashes, which move with extreme velocity in the form of a line of fire with sharp outlines, closely resembling the spark of an electric machine. The recent investigation of the shape of lightning discharges by means of extra rapid photographic dry plates (622) has shown that the path of a dis-

charge is not so sharply zigzag as is usually represented, but has more the shape of the course of a river as shown on a map, and with frequent branchings; 2, the *sheet* flashes, which, instead of being linear, like the preceding, fill the entire horizon without having any distinct shape. This kind, which is most frequent, appears to be produced in the cloud itself, and to illuminate the mass. According to Kundt, the number of sheet discharges is to the zigzag discharges as 11 : 6; and from spectrum observations it would appear that the former are brush discharges between clouds, while the latter are true electric discharges between the clouds and the earth. Another kind, called *heat lightning*, is ascribed to distant lightning flashes, which are below the horizon, but illuminate the higher strata of clouds, so that their brightness is visible at great distances; they produce no sound, probably in consequence of the fact of their being so far off that the rolling of thunder cannot reach the ear of the observer. There is, further, the very unusual phenomenon of *globe lightning*, or the flashes which appear in the form of globes of fire 18 inches in diameter. These, which are sometimes visible for as much as ten seconds, descend from the clouds to the earth with such slowness that the eye can follow them. They often rebound on reaching the ground; at other times they burst and explode with a noise like that of the report of many cannon. No adequate explanation has been given of these, though Planté with a large battery of his cells has imitated the phenomena.

The duration of the light of the first three kinds does not amount to the millionth of a second, as was determined by Wheatstone by means of his rotating wheel, which was turned so rapidly that the spokes were invisible: on illuminating it by the lightning flash, its duration was so short that whatever the velocity of rotation of the wheel, it appeared quite stationary; that is, its displacement is not perceptible during the time the lightning exists. The light produced by a lightning flash must be comparable to that of the sun in brightness, though it does not appear to us brighter than ordinary moonlight. But considering its excessively brief duration, and that the full effect of any light on the eye is only produced when its duration is at least the tenth of a second, it follows that a landscape continuously illuminated by the lightning flash would appear 100,000 times as bright as it actually appears to us during the flash.

Here also may be mentioned the phenomenon known as *St. Elmo's fire*, which occurs in a highly electric state of the atmosphere when the clouds are low. It is a sort of brush discharge (804), appearing like small flames issuing from prominent point-objects such as masts, tops of trees, lightning-conductors; it has also been observed on the points of helmets and lances, alpenstocks; it is of course most easily seen in the dark, and is accompanied by a slight rustling noise. On the sea during thunderstorms it is not uncommon on mastheads and yardarms.

1039. **Thunder.**—*Thunder* is the violent report which succeeds lightning. The occurrence of lightning and thunder is practically simultaneous, but an interval of several seconds is generally observed between the perception of these two phenomena, which arises from the fact that sound travels at the rate of only about 1100 feet in a second (230), while the passage of light is almost instantaneous. Hence an observer will hear the noise of

thunder only five or six seconds, for instance, after the lightning, according as the distance of the thunder-cloud is five or six times 1100 feet. The noise of thunder arises in some such manner as the crack of a whip or the report of a gun. The lightning discharge, whether by heating the air or by a purely mechanical action, such as is illustrated with Kinnersley's thermometer (fig. 749), causes it to expand with explosive violence, which is only possible by a compression of the surrounding air. This compressed air rushes in to fill the partial vacuum, forming itself, in turn, a partial vacuum, and thus, giving rise to alternate condensation and rarefaction, constitutes the wave-motion producing the sound. The depth of the note represents a great wave-length, and shows that the disturbance must have a great length. Near the place where the lightning strikes the sound is sharp and of short duration. At a greater distance a series of reports are heard in rapid succession. At a still greater distance the noise, feeble at first, changes into a prolonged rolling sound of varying intensity. If the lightning is at a greater distance than 14 or 15 miles, it is no longer heard, for sound is more imperfectly propagated through air than through solid bodies; hence there are lightning discharges without thunder; these occur at times when the sky is cloudless.

The rolling of thunder, the alternate rise and fall of the sound, occurs ordinarily with sheet lightning, less so with forked lightning, when the sound is short and crackling.

Various causes contribute to produce the rolling; one cause is the reflection from the ground, from clouds, and even from layers of air of unequal density. Lightning, too, is not a single discharge, but a series of discharges, each of which gives rise to a particular sound, and which are variously reflected by objects which they meet on their path. If two waves reach the ear simultaneously they strengthen each other if they are in the same phase, but if in different ones they interfere partially or wholly and the sound sinks. Thus it may happen that the sound after sinking may rise again. This is the well-known phenomenon of beats (263). The phenomenon has finally been ascribed to the irregularities in the path of the lightning itself, assuming that the air at each salient angle is at its greatest compression, which would produce the unequal intensity of the sound. The distance of the nearest point of a lightning flash is obtained in kilometres if we divide the time in seconds which elapses between the lightning flash and the beginning of the thunder by 3.

This is evident since $s = vt$, and v the velocity of sound is 330 metres or $\frac{1}{3}$ kilometre per second.

1040. **Effects of lightning.**—The lightning discharge is the electric discharge which strikes between a thunder-cloud and the ground. The latter, by the induction of the electricity from the cloud, becomes charged with contrary electricity; and when the tendency of the two electricities to combine exceeds the resistance of the air, the spark passes, which is often expressed by saying that 'a thunderbolt has fallen.'

The discharge usually falls first on the nearest and best conducting objects, and, in fact, trees, elevated buildings, metals, are particularly struck by the discharge. Hence it is imprudent to stand under trees during a thunderstorm.

The effects of lightning are very varied, and of the same kind as those of Leyden batteries (790), but of far greater power. The lightning discharge kills men and animals, ignites combustibles, melts metals, breaks bad conductors in pieces. When it penetrates the ground it melts the silicious substances on its path, and thus produces in the direction of the discharge those remarkable vitrified tubes called *fulgurites*, some of which are as much as 12 yards in length; in most cases there are found to be accumulations of water below such fulgurites. When it strikes bars of iron it magnetises them, and often inverts the poles of compass needles.

The action of lightning on trees is very singular. When struck by it they are sometimes stripped of their bark, either wholly or partially, or the wood is often split into thin laths, or into a mass of fibres. Franklin ascribed this to the sudden evaporation of the water.

After the passage of lightning a highly peculiar odour is frequently produced, like that perceived in a room in which an electric machine is being worked. This is due to the formation of *ozone*, a peculiar allotropic modification of oxygen. An electrified cloud forms with the earth below a condenser, the intervening mass of air being the dielectric. This mass of air is therefore in a state of strain, like the dielectric in a charged Leyden jar, and it is to this state of strain which precedes the actual discharge, rather than to the discharge itself, that is due the production of ozone.

Heated air conducts better than cold air, perhaps owing to its smaller density. Hence it is that large numbers of animals are often killed by a single discharge, as they crowd together in a storm, and a column of warm air rises from the group.

1041. **Return shock.**—This is a violent and sometimes fatal shock which men and animals experience, even when at a great distance from the place where the lightning discharge passes. It is caused by the inductive action which the thunder-cloud exerts on bodies placed within the sphere of its activity. These bodies are then, like the ground, charged with the opposite electricity to that of the cloud; but when the latter is discharged by the recombination of its electricity with that of the ground, the induction ceases, and the bodies reverting rapidly from the electric state to the neutral state, the concussion in question is produced—the *return* or *back shock*.

The return shock is always less violent than the direct one; there is no instance of its having produced any inflammation, yet plenty of cases in which it has killed both men and animals; in such cases no broken limbs, wounds, or burns are observed.

The return shock may be imitated by placing a gold-leaf electroscope connected by a wire with the ground near an electric machine; when the machine is worked, at each spark taken from the prime conductor the gold leaves of the electroscope suddenly diverge.

It is stated that persons struck by lightning often lose their lives only by a temporary injury to the nerves which control the act of respiration; so that under favourable circumstances such persons might probably be saved if respiration could be restored by artificial means.

1042. **Lightning-conductor.**—This was invented by Franklin in 1755.

There are two principal parts in a lightning-conductor, the rod and the conductor. The *rod* (fig. 1046) is a pointed bar of iron, preferably galvanised,

P, fixed vertically to a tube or rod of iron, which, by means of a collar *aa*, and tube *g*, is fitted on the roof of the edifice to be protected; it is from 6 to 10 feet in height, and its basal section is about 2 or 3 inches in diameter. The *conductor* is best formed of a wire rope, C, attached to the rod by a metal collar, *b*. The section of the metallic conductor ought to be about half a square inch, and the individual wires 0.04 to 0.06 inch in diameter: they ought to be twisted in strands, like an ordinary cord. The conductor is usually led into a well, a pond, or other continuous mass of water, and to connect it better with the ground it should terminate in a plate called an earth plate, or if a strand of wires the separate wires should be spread out. This plate should be of the same metal as the conductor, so as to avoid the possibility of local galvanic action (819), by which one or the other metal would be eaten away and the continuity destroyed. If there is no well near, a hole is dug in the soil to the depth of 6 or 7 yards, or to where the earth is permanently damp; where the ground is naturally dry it is advantageous to direct the rainfall from the roof towards where the plate is placed, and the ends of the conductor having been introduced, the hole is filled with powdered coke, which conducts very well. A good earth contact is obtained when it is possible to connect the wire conductors with large iron gas or water pipes.

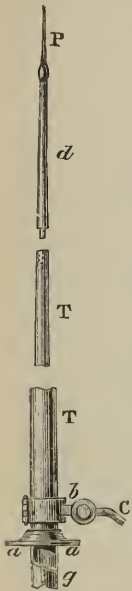

Fig. 1046

The action of a lightning-conductor is regarded as an illustration of the action of induction and of the property of points (780); when a storm cloud positively electrified, for instance, forms in the atmosphere, it acts inductively on the earth, producing a negative charge on bodies placed on the surface, the larger as these bodies are at a greater height. The density is then greatest on the highest bodies, which are therefore most exposed to the electric discharge; but if these bodies are provided with metal points, like the rods of conductors, the negative electricity flows into the atmosphere, and neutralises the positive electricity of the cloud. Hence the action of the lightning-conductor is twofold; not only does it tend to prevent the accumulation of electricity on the surface of the earth, but it also tends to restore the clouds to their natural state, both which concur in preventing lightning discharges. The quantity of electricity is, however, sometimes so abundant that the lightning-conductor is inadequate to discharge the electricity accumulated, and the lightning strikes; but the conductor receives the discharge, in consequence of the greater conductivity, and the edifice is preserved.

A conductor, to be efficient, ought to satisfy the following conditions:—
 (i.) The rod ought to be so large as not to be melted if the discharge passes.
 (ii.) It ought to terminate in a point, or in several points, to give readier issue to the electricity disengaged by induction from the ground. (iii.) Copper was formerly preferred to iron owing to its greater conductivity. But the lightning discharge is strictly analogous to the discharge of a Leyden jar, which according to circumstances may form either a continuous discharge

like a steady current, or a series of oscillations (800). In the latter case the discharge is restricted to the surface owing to the effect of impedance (1005), which may have a greater influence than the ohmic resistance, so that the advantage of the greater conducting power of copper disappears. The conductor must be continuous from the point to the ground, and the connection between the rod and the ground must be as intimate as possible; this is the most important of all, and the one point most frequently neglected in the older arrangements. A lightning-conductor with bad earth contact is not only useless but dangerous. In regard to this, it may be said that the best earth for contact is water. The continuity of the conductor may be tested by means of a voltaic cell and a portable form of galvanometer. (iv.) If the building which is provided with a lightning-conductor contains metallic surfaces of any extent, such as zinc roofs, metal gutters, or ironwork, these ought to be connected with the conductor, or, still better, have each a separate earth connection. If the last two conditions are not fulfilled, there is a great danger of lateral discharges—that is to say, that the discharge takes place between the conductor and the edifice, and then it increases the danger.

The requirements above laid down are based on the older view of the protection of buildings. Another mode of protection is based on the screening action of a closed conducting surface either continuous or formed of wire gauze. Such an enveloping conductor, as we have seen (765), protects a body inside it from external electric action, and probably does so also in the case of violent and sudden electric discharges. If a building could be surrounded by a wire cage which itself had good earth contact, this would be an efficient protection. Accordingly, an alternative plan aims at providing all the ridges, eaves and corners, and chimneys of a building with abundance of galvanised iron wire, preferably barbed, and with wire netting, all in metallic connection with each other and with the earth.

Copper conductors with a surface of 50 sq. mm. have been known to be raised to nearly a red heat by a lightning discharge, and such as have a section of 5 sq. mm. have frequently been melted. An estimate based on this fact gives for the quantity of electricity passing in such a discharge values of not less than 50 nor more than 290 coulombs.

1043. **Rainbow.**—The *rainbow* is a luminous phenomenon which appears in the clouds opposite the sun when they are resolved into rain. It consists of seven concentric arcs, presenting successively the colours of the solar spectrum. Usually only a single bow is perceived, but there are sometimes two: a lower one, the colours of which are very bright; and an external or *secondary* one, which is paler, and in which the order of the colours is reversed. In the interior rainbow the red is the highest colour; in the other rainbow the violet is. It is seldom that three bows are seen; theoretically a greater number may exist, but their colours become so faint that they cannot be perceived.

The phenomenon of the rainbow is produced by decomposition of the white light of the sun when it passes into the drops, and by its reflection from their inside face. In fact, the same phenomenon is witnessed in dew-drops and in jets of water—in short, wherever sunlight passes into drops of water under a certain angle.

The appearance and the extent of the rainbow depend on the position of the observer, and on the height of the sun above the horizon; hence only some of the rays refracted by the raindrops, and reflected in their concavity to the eye of the spectator, are adapted to produce the phenomenon. Those which do so are called *effective rays*.

To explain this let us suppose n (fig. 1047) to be a drop of water, into which a solar ray Sa penetrates. At a point of incidence, a , part of the light is reflected from the surface of the liquid; another, entering it, is decomposed and traverses the drop in the direction ab . Arrived at b , part of the light emerges from the raindrop, the other part is reflected from the concave surface, and tends to emerge at g . At this point the light is again partially reflected; the remainder emerges in a direction gO , which forms with the incident ray, Sa , an angle called the *angle of deviation*. It is such rays as gO , proceeding from the side next the observer, which produce

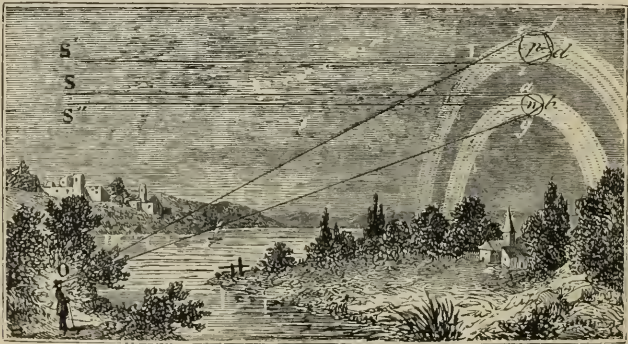

Fig. 1047

on the retina the sensation of colours, provided the light is sufficiently intense.

It can be shown mathematically that in the case of a series of rays which impinge on the same drop, and only undergo one reflection in the interior, the angle of deviation increases from the ray $S''n$, for which it is zero, up to a certain limit, beyond which it decreases, and that near this limit rays passing parallel into a drop of rain also emerge parallel. From this parallelism a beam of light is produced sufficiently intense to impress the retina; these are the rays which emerge parallel and are efficient.

As the different rays which compose a beam of white light are unequally refrangible, the maximum angle of deviation is not the same for all. For red rays the angle of deviation corresponding to the active rays is $42^{\circ} 2'$, and for violet rays it is $40^{\circ} 17'$. Hence, for all drops placed so that rays proceeding from the sun to the drop make, with those proceeding from the drop to the eye, an angle of $42^{\circ} 2'$, this organ will receive the sensation of red light; this will be the case with all drops situated on the circumference of the base of a cone, the summit of which is the spectator's eye; the axis of this cone is parallel to the sun's rays, and the angle formed by the two



opposed generating lines is $84^{\circ} 4'$. This explains the formation of the red band in the rainbow; the angle of the cone in the case of the violet band is $80^{\circ} 34'$.

The cones corresponding to each band have a common axis called the *visual axis*. As this right line is parallel to the rays of the sun, it follows that when this axis is on the horizon, the visual axis is itself horizontal, and the rainbow appears as a semicircle. If the sun rises, the visual axis sinks, and with it the rainbow. Lastly, when the sun is at a height of $42^{\circ} 2'$, the arc disappears entirely below the horizon. Hence the rainbow is never seen except in the morning and evening.

What has been said refers to the interior arc. The secondary bow is formed by rays which have undergone two reflections, as shown by the ray *S'idfeO*, in the drop *p*. The angle *S'IO* formed by the emergent and incident rays is called the angle of deviation. The angle is no longer susceptible of a maximum, but of a minimum deviation, which varies for each kind of rays, and to which also efficient rays correspond. It is calculated that the minimum angle from violet rays is $54^{\circ} 7'$, and for red rays only $50^{\circ} 57'$; hence it is that the red bow is here on the inside, and the violet arc on the outside. There is a loss of light for every internal reflection in the drop of rain, and therefore the colours of the secondary bow are always feebler than those of the internal one. The secondary bow ceases to be visible when the sun is 54° above the horizon.

The moon sometimes produces rainbows like the sun, but they are very pale.

1044. **Aurora borealis.**—The *aurora borealis*, or northern light, or more properly *polar aurora*, is a remarkable luminous phenomenon which is frequently seen in the atmosphere in high latitudes. Fig. 1048 represents an aurora borealis observed at Bossekop, in Lapland, lat. 70° , in the winter of 1838-39.

Plate III. represents a very beautiful aurora observed by Lemström on the north coast of Norway. The radial divergence of the aurora and the convergence towards a corona is due to an effect of perspective. The work of this author (*L'Aurora Boréale*, Gauthier Villars, Paris) is a storehouse of information on this subject.

A French scientific commission to the North observed 150 auroræ boreales in 200 days; it appears that at the poles, nights without an aurora borealis are quite exceptional, so that it may be assumed that they take place every night, though with varying intensity. They are visible at a considerable distance from the poles, and over an immense area. Sometimes the same aurora borealis has been seen at the same time at places so widely apart as Moscow, Warsaw, Rome, and Cadiz. The height of the aurora above the surface of the ground is probably lower than has generally been stated. Lemström holds that from 22 to 44 miles is a close approximation to the truth; and it may be regarded as certain that even in more southern latitudes the aurora is often seen much lower—at a height of two or three miles, for instance. In polar countries certain forms of aurora, more especially those of weak flames, are seen to proceed from the ground on the tops of certain mountains. They are most frequent at the equinoxes, and least so at the solstices. The number differs in different years, attaining

a maximum every 11 years at the same time as the sun-spots, and like these a minimum which is about five or six years from the maximum. The years 1844, 1855, 1866, and 1877 were poor in the appearance of the aurora.

There is, moreover, a period of about 60 years ; for the years 1728, 1780, and 1842 have been remarkable for the prevalence of the aurora. The last two periods are also remarkable for the occurrence of disturbances in the earth's magnetism.

Numerous hypotheses have been devised to account for the auroræ boreales. As they share the rotation of the earth, they must have an atmospheric origin. Their direction is not due north and south, but is always parallel to that of the dipping-needle, pointing to the magnetic pole ; this points to their intimate connection with the earth's magnetism. Magnetic

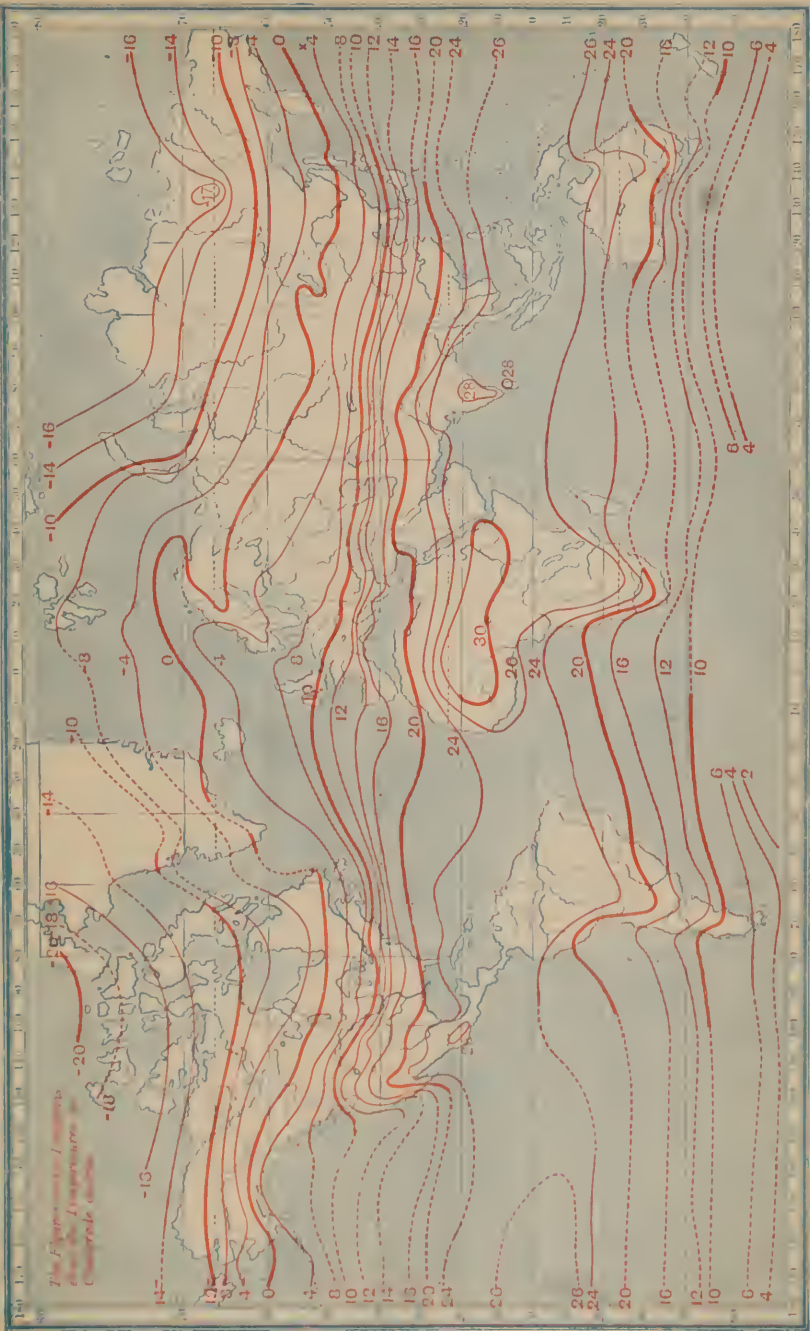

Fig. 1048

storms (738), and the prevalence of strong earth currents, are usually coincident with the appearance of especially brilliant auroræ.

It is probable that the attenuated air in the upper regions of the atmosphere is a fairly good conductor of electricity, and we know that when a conductor moves across the lines of force in a magnetic field, electromotive force is set up, and electric discharge may follow. Thus it is probable that the aurora is an electric discharge due to variations in the magnetic field which exists in the space surrounding the earth.

The spectrum of the aurora borealis has been found to consist of several lines in the green, and of an indistinct line in the blue ; to which must be added a red line due to the red protuberances ; these lines are the same as those of nitrogen, greatly rarefied and at a low temperature ; one special line between the green and the yellow, and called the *yellow* line, is so characteristic of the aurora that it is visible even when the eye can discern



The figures within / squares show the temperatures in Centigrade scale.

140 130 120 110 100 90 80 70 60 50 40 30 20 10 0 10 20 30 40 50 60 70 80 90 100 110 120 130 140

14 12 10 8 6 4 2 0 2 4 6 8 10 12 14 16 18 20 22 24 26 28 30 32 34 36 38 40 42 44 46 48 50 52 54 56 58 60 62 64 66 68 70 72 74 76 78 80 82 84 86 88 90 92 94 96 98 100 102 104 106 108 110 112 114 116 118 120 122 124 126 128 130 132 134 136 138 140

no other trace of this light ; this line has not been produced in laboratory experiments.

De la Rive held that auroræ boreales were due to electric discharges which take place in polar regions between the positive electricity of the atmosphere and the negative electricity of the earth. The positively electrified aqueous vapours are supposed to be carried by the equatorial current in the higher regions of the atmosphere to the poles, where the neutralisation takes place. These discharges produce luminous appearances of the same kind as are observed in Geissler's tubes ; and De la Rive showed by means of an apparatus specially devised for the purpose that the forms of the luminous phenomena are in accordance with this theory.

By direct experiments Lemström has been able to imitate and reproduce a peculiar form of aurora observed in winter as a flame-like appearance on the tops of two mountains 800 and 1100 metres in height, and to show that it is of electric origin. He erected on the summit of a hill a system of pointed rods extending over a surface of nearly 4000 square feet ; each rod was carefully insulated from the earth by means of a Mascart's insulator (fig. 707), but was connected with the rest, and an insulated wire led down from this system into the valley, where it was connected with one terminal of a galvanometer, the other being put to earth. The existence of a positive current from the air to the earth was observed, and at the same time yellowish-white columns of light, reaching to a height of 120 metres, were observed to issue from the points. Observed with the spectroscope it gave the characteristic lines between D and E.

Making similar experiments on even a larger scale in Lapland on a detached peak, he observed that the characteristic luminous phenomena were produced there, while the neighbouring peaks remained dark.

The investigations of Exner relative to the fall of atmospheric electric potential lend a further support to the view that the aurora is due to electricity. In the polar regions the rate of fall of potential is 13 times greater in summer, and 18 times greater in winter than at the equator. Hence an electric phenomenon, which depends on the magnitude of this fall of potential, must be more intense in winter and in high latitudes than in summer and in the torrid zones.

The occurrence of irregular currents of electricity which manifest themselves by abnormal disturbances of telegraphic communications is not infrequent : such currents have received the name of *earth currents*. Sabine held that irregular magnetic disturbances are due to a peculiar action of the sun, and are probably independent of its radiant heat and light. It has also been ascertained that the aurora borealis, as well as earth currents, invariably accompanies these magnetic disturbances. According to the late Balfour Stewart, auroræ and earth currents are to be regarded as secondary phenomena due to small but rapid changes in the earth's magnetism : he likened the body of the earth to the magnetic core of a Ruhmkorff's coil (975) : the lower strata of the atmosphere forming the insulator, while the upper and rarer, and therefore electrically conducting, strata may be considered as the secondary coil.

On this analogy the sun may perhaps be likened to the primary current which performs the part of producing changes in the magnetic state of the

core. Now in Ruhmkorff's coil the energy of the secondary current is derived from that of the primary current. Thus, if the analogy is correct, the energy of the aurora borealis may in like manner come from the sun ; but until we know more of the connection between the sun and terrestrial magnetism, these ideas are to be accepted with some reserve.

CLIMATOLOGY

1045. **Mean temperature.**—The *mean daily temperature* is that obtained by adding together 24 hourly observations, and dividing by 24. A very close approximation to the mean temperature is obtained by taking the mean of the highest and lowest temperatures of the day and of the night, which are determined by means of the maximum and minimum thermometers. These ought to be protected from the sun's rays, to be raised above the ground, and far from all objects which might influence them by their radiation.

The temperature of a month is the mean of the temperature of 30 days, and the temperature of the year is the mean of those of 12 months. Finally the temperature of a place is the mean of its annual temperatures for a great number of years. The mean temperature of London is 8.28° C., or 46.9° F. The temperatures in all cases are those of the air, and not those of the ground.

1046. **Causes which modify the temperature of the air.**—The principal causes which modify the temperature of the air are the latitude of a place, its height, the direction of the winds, and proximity of seas.

Influence of the latitude.—The influence of the latitude arises from the greater or less obliquity of the solar rays, for as the quantity of heat absorbed is greater the more perpendicular are the rays, the heat absorbed decreases from the equator to the poles, for the rays become more oblique. This loss is, however, in summer, in the temperate and arctic zones, partially compensated by the length of the days. Under the equator, where the length of the days is constant, the temperature is almost invariable ; in the latitude of London, and in more northerly countries, where the days are very unequal, the temperature varies greatly ; but in summer it sometimes rises almost as high as under the equator. The lowering of the temperature produced by the latitude is small ; thus, in a latitude 115 miles north of Paris, the temperature is only 1° C. lower.

Influence of height.—The height of a place above the sea-level has a much more considerable influence on the temperature than its latitude.

The cooling on ascending in the atmosphere has been observed in balloon ascents, and a proof of it is seen in the perpetual snows which cover the highest mountains. It is due in part to the greater rarefaction of the air, which necessarily diminishes its absorbing power ; besides which the air is at a greater distance from the ground, which heats it by contact ; and finally, dry air is very diathermanous.

The law of the diminution of temperature corresponding to greater heights in the atmosphere has not been made out, in consequence of the numerous disturbing causes which modify it, such as the prevalent winds, the hygrometric state, the time of day, the season of the year, &c. The

71 Forces in this Isotherm is
from the temperatures of
Celsius degrees

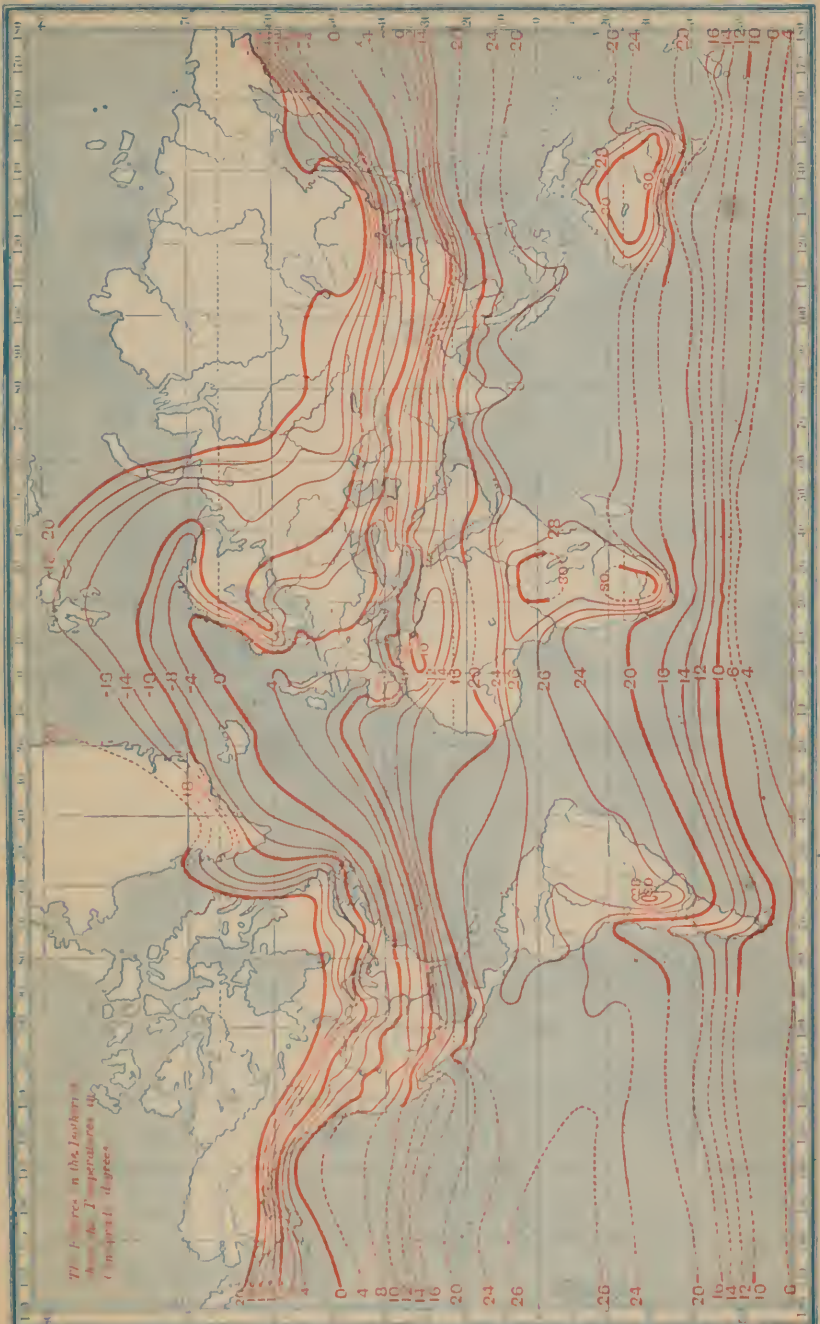

difference between the temperatures of two places at unequal heights is not proportional to the difference of level, but for moderate heights an approximation to the law may be made. As the mean of a series of very careful observations made during balloon ascents, a diminution of 1° C. corresponded to an increase in height of 210 metres.

It will thus be seen that at a certain height above the ground there must be a surface or layer where the temperature is uniformly zero. The height of this isothermal surface (1048) will vary materially with the time of the year, being lower in the cold months : it varies also with the time of day, rising rapidly about midday. In summer this height may be taken at from 3400 to 3700 metres above the sea-level.

Direction of winds.—As winds share the temperature of the countries which they have traversed, their direction exercises great influence on the air in any place. In Paris, the hottest winds are the south ; then come the south-east, the south-west, the west, the east, the north-west, north, and lastly, the north-east, which is the coldest. The character of the wind changes with the seasons ; the east wind, which is cold in winter, is warm in summer.

Proximity of the sea.—The neighbourhood of the sea tends to raise the temperature of the air, and to render it uniform. The average temperature of the sea in equatorial and polar countries is always higher than that of the atmosphere. With reference to the uniformity of the temperature, it has been found that in temperate regions—that is, from 25° to 50° of latitude—the difference between the highest and lowest temperature of a day does not exceed, on the sea, 2° to 3° ; while upon the continent the difference amounts to from 12° to 15° . In islands the uniformity of temperature is very perceptible. In continents, on the contrary, the winters for the same latitudes become colder, and the difference between the temperature of summer and winter becomes greater.

1047. **Gulf Stream.**—A similar influence to that of the winds is exerted by currents of warm water. To one of these, the Gulf Stream, the mildness of the climate in the north-west of Europe is mainly due. This great body of water, taking its origin in equatorial regions, flows through the Gulf of Mexico, whence it derives its name ; passing by the southern shores of North America, it makes its way in a north-westerly direction across the Atlantic, and finally washes the coast of Ireland and the north-west of Europe generally. Its temperature in the Gulf is about 28° C. ; and it is usually a little more than 5° C. higher than the rest of the ocean on which it floats, owing to its lower specific gravity. To its influence is due the milder climate of West Europe as compared with that of the opposite coast of America ; thus the river Hudson, in the latitude of Rome, is frozen over three months in the year. It also causes the polar regions to be separated from the coasts of Europe by a girdle of open sea ; and thus the harbour of Hammerfest is open the year round. Besides this influence in thus moderating climate, the Gulf Stream is an important help to navigators.

1048. **Isothermal lines.**—When on a map all the points whose temperature is known to be the same are joined, curves are obtained which Humboldt first noticed, and which he called *isothermal lines*. If the temperature of a place only varied with the obliquity of the sun's rays—that is, with the

latitude—*isothermal lines* would all be parallel to the equator ; but as the temperature is influenced by many local causes, especially by the height, the *isothermal lines* are always more or less curved. On the sea, however, they are almost parallel. Maps vii, viii, and ix represent these lines for the Year, for January, and for July.

A distinction is made between *isothermal lines*, *isotheral lines*, and *isochimenal lines*, where the *mean general*, the *mean summer*, and the *mean winter* temperatures are respectively constant. An *isothermal zone* is the space comprised between two *isothermal lines*. Kupffer also distinguishes *isogeothermic lines* where the mean temperature of the soil is constant.

1049. **Climate.**—By the climate of a place is understood the whole of the meteorological conditions to which the place is subjected ; its mean annual temperature, summer and winter temperatures, and the extremes within which these are comprised. Some writers distinguish seven classes of climates, according to their mean annual temperature : a *hot climate* from 30° to 25° C. ; a *warm climate* from 25° to 20° C. ; a *mild climate* from 20° to 15° C. ; a *temperate climate* from 15° to 10° C. ; a *cold climate* from 10° to 5° C. ; a *very cold climate* from 5° to zero C. ; and an *arctic climate* where the temperature is below zero.

Those climates, again, are classed as *constant climates* where the summer and winter temperatures do not differ from the mean temperature by more than 6° or 8° ; *variable climates*, where the difference amounts to from 16° to 20° ; and *extreme climates*, where the difference is greater than 30° . The climates of Paris and London are variable ; those of Pekin and New York are extreme. Island climates are generally little variable, as the temperature of the sea is nearly constant ; and hence the distinction between land and sea climates. Marine climates are characterised by the fact that the difference between the temperature of summer and winter is always less than in the case of continental climates. But the temperature is by no means the only character which influences climate ; there are, in addition, the moisture of the air, the quantity and frequency of the rains, the number of storms, the direction and intensity of the winds, and the nature of the soil.

1050. **Distribution of temperature on the surface of the globe.**—The temperature of the air on the surface of the globe decreases from the equator to the poles ; but it is subject to perturbing causes so numerous and so purely local, that its decrease cannot be expressed by any law. It has hitherto not been possible to do more than obtain by numerous observations the mean temperature of each place, or the maximum and minimum temperatures. The following table gives a general idea of the distribution of heat in the Northern Hemisphere.

Mean temperature at different latitudes

Abyssinia $31\cdot0^{\circ}$ C.	Naples $16\cdot7^{\circ}$ C.
Calcutta $28\cdot5$	Mexico $16\cdot6$
Jamaica $26\cdot1$	Marseilles $14\cdot1$
Senegal $24\cdot6$	Constantinople $13\cdot7$
Cairo $22\cdot4$	Pekin $12\cdot7$
Constantine $17\cdot2$	Paris $10\cdot8$

The figures on the isotherms show the Temperatures in Centigrade degrees.

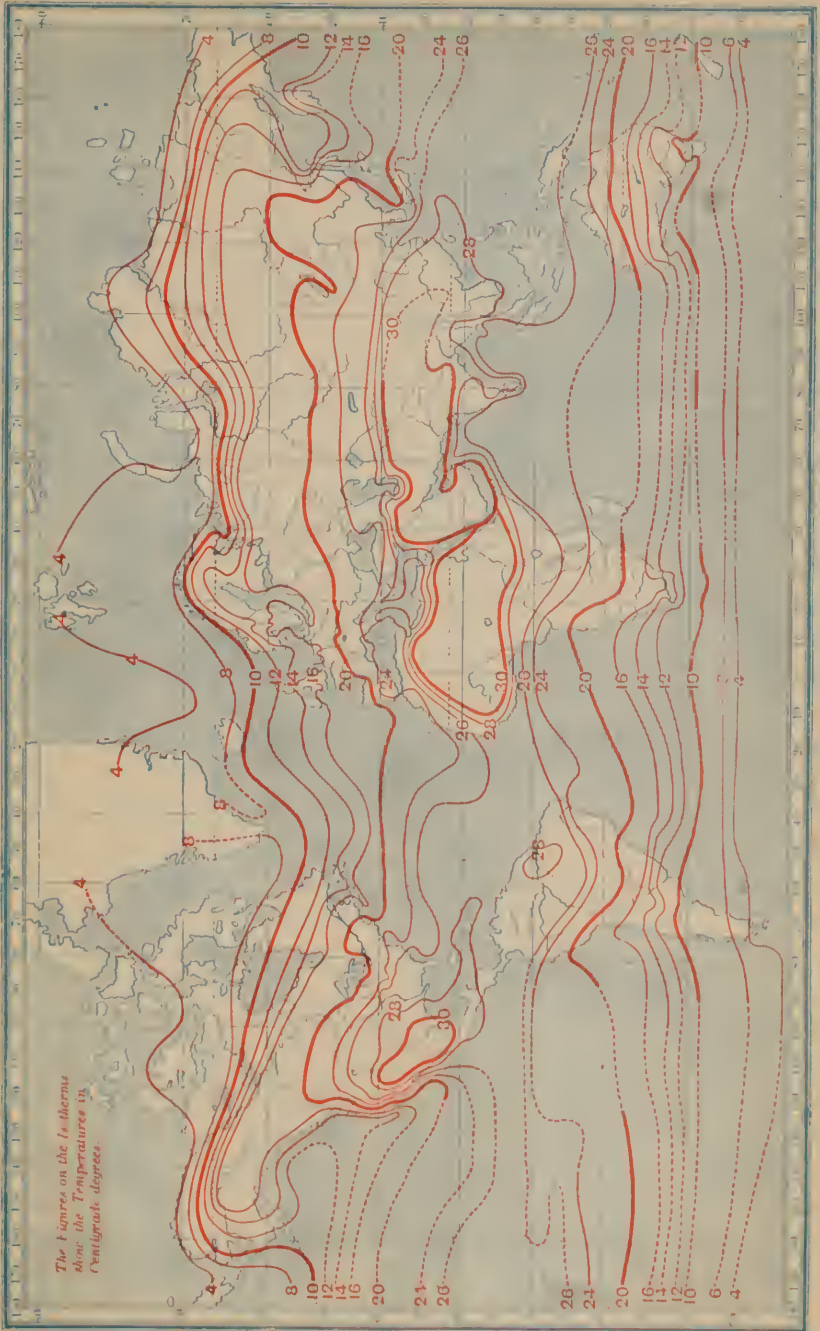



Brussels	10·2° C.	Moscow	3·6° C.
Strasbourg	9·8	St. Petersburg	3·5
Geneva	9·7	St. Gothard	-1·0
Boston	9·0	Greenland	-7·7
London	8·3	Melville Island	-18·7
Stockholm	5·6		

These are mean yearly temperatures. The highest temperature which has been observed on the surface of the globe is 47·4° at Esne, in Egypt, and the lowest is -75° in the Arctic Expedition of 1876; which gives a difference of 122° between the extreme temperatures observed on the surface of the globe.

The highest temperature observed at Paris was 38·4° on July 8, 1793, and the lowest -23·5° on December 26, 1798. The highest observed at Greenwich was 35° C. in 1808, and the lowest -20° C. in 1838.

No arctic voyagers have succeeded in reaching the poles, in consequence of the seas round them being completely frozen, and hence the temperature there is not known. In our hemisphere the existence of a single *glacial pole*—that is, a place where there was the maximum cold—has been long assumed. But the bendings which the isothermal lines present in the Northern Hemisphere have shown that in this hemisphere there are two cold poles—one in Asia, to the north of Taimur Bay; and the other in America, north of Barrow's Straits, about 15° from the earth's north pole. The mean temperature of the first of these poles has been estimated at -17°, and that of the second at -19°. With respect to the southern hemispheres, the observations are not sufficiently numerous to decide whether there are one or two poles of greatest cold, or to determine their position.

1051. **Temperatures of lakes, seas, and springs.**—In the tropics the temperature of the sea is generally the same as that of the air; in polar regions the sea is always warmer than the atmosphere.

The temperature of the sea in the torrid zone is always about 26° to 27° at the surface: it diminishes as the depth increases, and in temperate as well as in tropical regions the temperature of the sea at great depths is between 2·5° and 3·5°. The low temperature of the lower layers is caused by submarine currents which carry the cold water of the polar seas towards the equator.

The variations in the temperature of lakes are more considerable; their surface, which becomes frozen in winter, may become heated to 20° or 25° in summer. The temperature of the bottom, on the contrary, is virtually 4°, which is that of the maximum density of pure water.

Springs, which arise from rain water which has penetrated into the crust of the globe to a greater or less depth, necessarily tend to assume the temperature of the terrestrial layers which they traverse. Hence, when they reach the surface their temperature depends on the depth which they have attained. If this depth is that of the layer of invariable temperature, the springs have a temperature of 10° or 11° in this country, for this is the temperature of this layer, or about the mean annual temperature. If the springs are not very copious, their temperature is raised in summer and cooled in winter by that of the layers which they traverse in passing from the invariable layer to the

surface. But if they come from below the layer of invariable temperature their temperature may considerably exceed the mean temperature of the place, and they are then called *thermal springs*. The following list gives the temperatures of some of them :—

Wildbad	37·5° C.
Vichy	40
Bath	46
Ems	46
Baden-Baden	67·5
Chaudes-Aigues	88
Trincheras	97
Great Geysir, in Iceland, at a depth of 66 feet	124

From their high temperature they have the property of dissolving many mineral substances which they traverse in their passage, and hence form *mineral waters*. The temperature of mineral waters is not modified in general by the abundance of rain or of dryness ; but it is by earthquakes, after which they have sometimes been found to rise and at other times to sink.

1052. **Distribution of land and water.**—The distribution of water on the surface of the earth exercises great influence on climate. The area covered by water is considerably greater than that of the dry land ; and the distribution is unequal in the two hemispheres. The entire surface of the globe occupies about 200 millions of square miles, nearly three-fourths of which are covered by water ; that is, the extent of the water is nearly three times as great as that of the land. The surface of the sea in the Southern Hemisphere is to that in the Northern in about the ratio of 13 to 9.

The depth of the open sea is very variable ; the lead generally reaches the bottom at about 300 to 450 yards ; in the ocean it is often 1300 yards, and instances are known in which a bottom has not been reached at a depth of 4500. It has been computed that the total mass of the water does not exceed that of a liquid layer surrounding the earth with a depth of about 1100 yards.

PROBLEMS AND EXAMPLES IN PHYSICS



I. MECHANICS

1. A body being placed successively in the two pans of a balance, requires 180 grammes to hold it in equilibrium in one pan, and 181 grammes in the other; required the weight of the body to a milligramme.

From the formula $x = \sqrt{p'p}$ we have

$$x = \sqrt{180 \times 181} = 180.499 \text{ gr.}$$

2. What resistance does a nut offer when placed in a pair of nutcrackers at a distance of $\frac{3}{4}$ of an inch from the joint, if a force of 5 pounds applied at a distance of 4 inches from the joint is just sufficient to crack it? *Ans.* $26\frac{2}{3}$ pounds.

3. What force is required to raise a cask weighing 6 cwt. into a cart 0.8 metre high along a ladder 2.75 metres in length? *Ans.* $195\frac{1}{2}$ pounds.

4. If a horse can move 30 cwt. along a level road, what can it move along a road the inclination of which is 1 in 80, the coefficient of friction on each road being $\frac{1}{10}$?

Ans. $26\frac{3}{4}$ cwt.

5. The piston of a force-pump has a diameter of 8 centimetres, and the arms of the lever by which it is worked are respectively 12 and 96 centimetres in length; what force must be exerted at the longer arm if a pressure of 12.36 pounds per sq. cm. is to be applied? *Ans.* 77.69 pounds.

6. A stone is thrown vertically downwards from a balloon with a velocity of 50 metres per second. How soon will the velocity amount to 99 metres per second, and through what distance will the stone have fallen?

To find the time requisite for the body to have acquired the velocity of 99 metres per second, we have

$$v = V + gt;$$

in which V is the initial velocity, g the acceleration of gravity, which, with sufficient approximation, is equal to 9.8 (metre, second), and t the time. Substituting these values, we have

$$t = \frac{99 - 50}{9.8} = \frac{49}{9.8} = 5 \text{ seconds.}$$

For the space traversed we have

$$s = Vt + \frac{1}{2}gt^2 = 50 \times 5 + 4.9 \times 25 = 372.5 \text{ metres.}$$

7. A projectile was thrown vertically upwards to a height of 510.22 m. Disregarding the resistance of the air, what was the initial velocity of the body?

The velocity is the same as that which the body would have acquired on falling from a height of 510.22 metres.

From the formula $v = \sqrt{2gs}$ we get

$$v = \sqrt{2 \times 9.8 \times 510.22} = \sqrt{10000} = 100 \text{ metres per sec.}$$

8. A stone is thrown vertically upwards with an initial velocity of 100 metres per second. After what time would it return to its original position?

The time of rising and falling is the same, but the time of falling is $\frac{v}{g}$ (from the formula $v=gt$) or $\frac{100}{9.8} = 10.2$, which is half the time required; therefore $t = 20.4$ sec.

9. A stone is thrown vertically upwards with an initial velocity of 100 metres per second; after x seconds a second stone is thrown with the same velocity. The second stone is rising 8.7 seconds before it meets the first. What interval separated the throws?

The rising stone will have the velocity $v = V - gt$, whence $v = 100 - 9.8 \times 8.7$. On the other hand, the falling stone, at the moment the stones meet, will have the velocity given by the equation $v = gt'$, in which t' is the time during which the stone falls before it meets the second one. This time is equal to 8.7 seconds + $x - \frac{100}{9.8}$. Hence its velocity is

$$v = 9.8 \left(8.7 + x - \frac{100}{9.8} \right).$$

Equating the two values of v and reducing, we obtain $x = 3$ seconds.

10. A body moving with a uniformly accelerated motion traverses a space of 1000 metres in 10 seconds. What would be the space traversed during the eighteenth second if the motion continued in the same manner?

The formula $s = \frac{1}{2}ft^2$ gives for the acceleration $f = 20$ (metre, second).

The space traversed during the eighteenth second will be equal to the difference of the space traversed in 18 seconds and that traversed at the end of the seventeenth.

$$x = \frac{20 \times 18^2}{2} - \frac{20 \times 17^2}{2} = 350 \text{ metres.}$$

11. A cannon-ball is shot vertically upwards with a velocity of 250 metres per second. After what interval of time will its velocity have been reduced to 54 metres per second under the retarding influence of gravity, and what space will have been traversed by the ball at the end of this time?

If t be the time, then at the end of each second the initial velocity will be diminished by 9.8 m./sec. Hence we shall have

$$54 = 250 - t \times 9.8, \text{ whence } t = 20 \text{ seconds;}$$

and for the space traversed

$$= 250 \times 20 - \frac{9.8 \times 20^2}{2} = 3040 \text{ metres.}$$

12. A body falls in air from a height of 4000 metres. Required the time of its fall and its velocity when it strikes the ground.

From the formula $s = \frac{1}{2}gt^2$ we have for the time $t = \sqrt{\frac{2s}{g}}$; and, on the other

hand, from the formula for velocity $v = gt$ we have $t = \frac{v}{g} = \frac{200}{9.8} = 20.4$.

Hence $\frac{v}{g} = \sqrt{\frac{2s}{g}}$, from which $v = \sqrt{2gs}$, and substituting the values for s and g , $v = 280$ m./sec.

13. A stone is thrown into a pit 150 metres deep and reaches the bottom in 4 seconds. With what velocity was it thrown, and what velocity had it acquired on reaching the bottom? *Ans.* The stone was thrown with a velocity of 17.9, and on reaching the bottom had acquired the velocity 57.1.

14. A stone is thrown downwards from a height of 150 metres with a velocity of 10 metres per second. How long will it require to fall?

The distance through which the stone falls is equal to the sum of the distances through which it would fall in virtue of its initial impulse and of that which it would traverse under the influence of gravity alone ; that is, $150 = 10t + \frac{9 \cdot 8 t^2}{2}$.

Taking the positive value only we get $t = 4 \cdot 61$ seconds.

15. How far will a heavy body fall in vacuo during the time in which its velocity increases from 40·25 feet per second to 88·55 feet per second ?

Ans. Taking the value of g at 32·2, the body will fall through 96·6 feet.

16. Required the time of oscillation of a simple pendulum whose length is 0·9938 metre, and in a place where the intensity of gravity is 9·81.

From the formula $t = 2\pi \sqrt{\frac{l}{g}}$, in which t expresses the time of one oscillation, l the length of the pendulum, and g the intensity of gravity, we have

$$t = 2 \times 3 \cdot 1416 \sqrt{\frac{0 \cdot 99384}{9 \cdot 81}} = 2 \text{ seconds.}$$

17. In a place at which the length of the seconds pendulum is 0·99384, it is required to know the length of a pendulum which makes one oscillation in 10 seconds.

In the present case, as g remains the same in the general formula, and t varies, the length l must vary also. We shall have, then,

$$2 : 10 = 2\pi \sqrt{\frac{l}{g}} : 2\pi \sqrt{\frac{l'}{g}}$$

from which, reducing and introducing the values, we have

$$l' = 5^2 \times 0 \cdot 99384 = 24 \cdot 846.$$

18. A pendulum, the length of which is 195 cm., makes 30,841 oscillations in a day. Required the length of the seconds pendulum. *Ans.* 99·385 cm.

19. A pendulum clock loses 5 seconds in a day. By how much must it be shortened to keep correct time ?

Let s = the number of seconds in one day, and s' the number indicated by the clock, then $s : s' = n : n' = l' : l = \sqrt{l'} : \sqrt{l} \therefore 86400 : 86395 = 1 : \sqrt{l/l'} = 1 : \sqrt{x}$
 $\therefore x = \cdot 9998843$.

Hence $1 - x = 0 \cdot 0001157$ *Ans.*

20. What is the normal acceleration of a body which traverses a circle of 4·2 metres diameter with a linear velocity of 3 metres per second ? *Ans.* 4·286 metres.

21. A force brought to bear on a body moving at the rate of 50 ft./sec. brings it to rest in 5 seconds. Through what distance will the body move after the force begins to act ? *Ans.* 125 ft.

22. An iron ball falls from a height of 68 cm. on a horizontal iron plate, and rebounds to a height of 27 cm. Required the coefficient of elasticity of the iron.

If an imperfectly elastic ball with the velocity v strikes against a plate, it rebounds with the velocity $v_1 = -k v$, from which, disregarding the sign, $k = \frac{v_1}{v}$. Now we have the velocity $v_1 = \sqrt{2gh_1}$, and $v = \sqrt{2gh}$, from which $k = \frac{\sqrt{h_1}}{\sqrt{h}}$. Substituting the corresponding values, we get $k = 0 \cdot 63$.

23. Two inelastic bodies, weighing respectively 100 and 200 pounds, strike against each other with velocities of 50 and 20 feet ; what is their common velocity, after the impact ? *Ans.* 30, or 3·3, according as they move in the same or in opposite directions before impact.

24. 160 oz. of gold are coined into 623 sovereigns. If 89 sovereigns in one scale pan of a balance just balance 40 oz. in the other, how many sovereigns in the second scale pan will balance 640 oz. in the first ? *Ans.* 4361.

II. HYDROMECHANICS

1. The force with which a hydraulic press is worked is 20 pounds; the arm of the lever on which this force acts is 5 times as long as that of the resistance; lastly, the area of the large piston is 70 times that of the smaller one. Required the force transmitted to the large piston.

$$\begin{aligned} \text{Force on smaller piston} &= 20 \times 5 = P \\ \text{,, larger ,,} &= 70 P = 7000 \text{ pounds.} \end{aligned}$$

2. The force with which a hydraulic press is worked being 30 kilos., and the arm of the lever by which this force is applied being 10 times as long as that of the resistance, and the diameter of the small piston being 2 cm.; find the diameter of the large piston, in order that a force of 2000 kilos. may act upon it. *Ans.* 5.164 cm.

3. What force would be necessary to support a cubic decimetre of platinum in mercury at zero? Density of mercury 13.6 and that of platinum 21.5.

From the formula $P = VD$ the weight of a cubic decimetre of platinum is $1 \times 21.5 = 21.5$ kilos, and that of a cubic decimetre of mercury is $1 \times 13.6 = 13.6$ kilos. From the principle of Archimedes, the immersed platinum loses part of its weight equal to that of the mercury which it displaces. Its weight in the liquid is therefore $21.5 - 13.6 = 7.9$, and this represents the force required.

4. Given a body A which weighs 7.55 grammes in air, 5.17 gr. in water, and 6.35 gr. in another liquid, B ; required from these data the density of the body A and that of the liquid B .

The weight of the body A loses in water $7.55 - 5.17 = 2.38$ grammes; this represents the weight of the displaced water. In the liquid B it loses $7.55 - 6.35 = 1.2$ gr.; this is the weight of the same volume of the body B , as that of A and of the displaced water. The specific gravity of A is therefore

$$\frac{7.55}{2.38} = 3.172, \text{ and that of } B \frac{1.20}{2.38} = 0.504.$$

5. A cube of lead, the side of which is 4 cm., is to be supported in water by being attached to a sphere of cork. What must be the diameter of the latter, the specific gravity of cork being 0.24, and that of lead 11.35?

The volume of the lead is 64 cubic centimetres; its weight in air is therefore 64×11.35 , and its weight in water $64 \times 11.35 - 64 = 662.4$ gr.

If r is the radius of the sphere in centimetres, its volume in cubic centimetres will be $\frac{4\pi r^3}{3}$, and its weight in grammes is $\frac{4\pi r^3 \times 0.24}{3}$. Now, as the weight of the displaced water is obviously $\frac{4}{3}\pi r^3$ in grammes, there will be an upward buoyancy represented by $\frac{4\pi r^3}{3} - \frac{4\pi r^3 \times 0.24}{3} = \frac{4\pi r^3 \times 0.76}{3}$ which must be equal to the weight of the lead; that is, $\frac{4\pi r^3 \times 0.76}{3} = 662.5$, from which $r = 5.925$ cm. and the diameter = 11.85 cm.

6. A cylindrical steel magnet 15 cm. in length and 1.2 mm. in diameter is loaded at one end with a cylinder of platinum of the same diameter and of such a length that when the solid thus formed is in mercury, the free end of the steel projects 10 mm. above the surface. Required the length of this platinum, the specific gravity of steel being 7.8, and of that of platinum 21.5.

The weight of the steel in grammes will be $15\pi r^2 \times 7.8$, and of the platinum $x\pi r^2 \times 21.5$.

These are together equal to the weight of the displaced mercury, which is $\pi r^2 (14 + x) 13.6$, from which $x = 9.29$ cm.

7. A cylindrical silver wire 1.5 mm. in diameter weighs 3.2875 grammes ; it is to be covered with a layer of gold 0.2 mm. in thickness. Required the weight of the gold, the specific gravity of silver being 10.47 and that of gold 19.26.

If r is the radius of the silver wire and R its radius when covered with gold, then $r = 0.075$ cm. and $R = 0.095$ cm. The volume of the silver wire will be $\pi r^2 l$ and its weight $\pi r^2 l \times 10.47$, from which $l = 17.768$ cm.

The volume of the layer of gold is

$$\pi (R^2 - r^2) \times 17.768,$$

and its weight

$$\pi (0.095^2 - 0.075^2) \times 17.768 \times 19.26 = 3.656 \text{ gr. nearly.}$$

8. A kilogramme of copper is to be drawn into wire having a diameter of 0.16 cm. What length will it yield? Specific gravity of copper 8.88.

The wire produced represents a cylinder l cm. in length, the weight of which is $\pi r^2 l \times 8.88$, and this is equal to 1000 grammes. Hence $l = 56.0085$ metres.

9. The specific gravity of cast copper being 8.79, and that of copper wire being 8.88, what change of volume does a kilogramme of cast copper undergo in being drawn into wire? Ans. 1.024 cc.

10. Determine the volumes of two liquids, the densities of which are respectively 1.3 and 0.7, and which produce a mixture of three volumes having the density 0.9.

If x and y are the volumes, then from $P = VD$, $1.3x + 0.7y = 3 \times 0.9$ and $x + y = 3$, from which $x = 1$ and $y = 2$.

11. The specific gravity of zinc being 7 and that of copper 9, what weight of each metal must be taken to form 50 grammes of an alloy having the specific gravity 8.2, it being assumed that the volume of the alloy is exactly the sum of the alloyed metals?

Let $x =$ the weight of the zinc, and y that of the copper, then $x + y = 50$, and from the formula $V = \frac{P}{D}$, since the volume is unchanged $\frac{x}{7} + \frac{y}{9} = \frac{50}{8.2}$. From these two equations we get $x = 17.07$, and $y = 32.93$.

12. A platinum sphere 3 cm. in diameter is suspended to the beam of an accurate balance, and is completely immersed in mercury. It is exactly counterbalanced by a copper cylinder of the same diameter completely immersed in water. Required the height of the cylinder. Specific gravity of mercury 13.6, of copper 8.8, and of platinum 21.5. Ans. 2.025 cm.

13. To balance an ingot of platinum 27 grammes of brass are placed in the other pan of the balance. What weight would have been necessary if the weighing had been effected in vacuo? The density of platinum is 21.5, that of brass 8.3, and air under a pressure of 760 mm. and at the temperature 0° has 1/770 the density of water.

The weight of brass in air is not 27 grammes, but this weight minus the weight of a volume of air equal to its own.

Since $P = VD \therefore V = \frac{P}{D}$ and the weight of the air is $\frac{P}{D \times 770} = \frac{27}{8.3 \times 770}$.

By similar considerations, if x is the weight of platinum in vacuo, its weight in air will be x minus the weight of air displaced, that is $x - \frac{x}{21.5 \times 770}$, and this weight is equal to that of the true weight of the brass ; and we have

$$x - \frac{x}{21.5 \times 770} = 27 - \frac{27}{8.3 \times 770}; \text{ from which } x = 26.956.$$

14. A body loses in carbonic acid gas 1.15 gr. of its weight. What would be its loss of weight in air and in hydrogen respectively?

Since a litre of air at 0° and 760 mm. weighs 1.293 gr. the same volume of carbonic acid weighs $1.293 \times 1.524 = 1.97$ gr. We shall, therefore, obtain the volume of carbonic acid corresponding to 1.15 gr. by dividing this number by 1.97, which gives 0.5837 litre. This being then the volume of the body, it displaces that

volume of air, and therefore its loss of weight in air is $0.5837 \times 1.293 = 0.7547$ gr. and in hydrogen $0.5837 \times 1.293 \times 0.069 = 0.052076$.

15. Calculate the ascensional force of a spherical balloon of oiled silk which, when empty, weighs 62.5 kilos., and which is filled with impure hydrogen, the density of which is $1/13$ that of air. The oiled silk weighs 0.250 kilo. per sq. m.

The surface of the balloon is $\frac{62.5}{0.25} = 250$ sq. m. This surface being that of a sphere, is equal to $4\pi R^2$, whence $4\pi R^2 = 250$ and $R = 4.459$; therefore $V = \frac{4\pi R^3}{3} = 371.52$ cubic metres.

The weight of air displaced is 371.52×1.293 kilo. = 480.375 kilos.; the weight of the hydrogen is 36.88 kilos., and therefore the ascensional force is $480.375 - (36.88 + 62.5) = 380.995$ kilos.

16. A balloon 4 metres in diameter is made of the same material and filled with the same hydrogen as above. How much hydrogen is required to fill it, and what weight can it support?

The volume is $\frac{4}{3}\pi R^3 = 33.51$ cubic metres, and the surface $4\pi R^2 = 50.265$ sq. m. The weight of the air displaced is $33.51 \times 1.293 = 43.328$ kilos., and that of the hydrogen is from the above data 3.333 kilos., while the weight of the material is 12.566 kilos. Hence the weight which the balloon can support is

$$43.328 - (12.566 + 3.333) = 27.429 \text{ kilos.}$$

17. Under the receiver of an air-pump is placed a balance, to which are suspended two cubes; one of these is 3 cm. in the side, and weighs 26.324 gr.; and the other is 5 cm. in the side, and weighs 26.2597 grammes. When a partial vacuum is made these cubes just balance each other. What is the pressure? *Ans.* 37.4 cm.

18. A soap-bubble 8 cm. in diameter was filled with a mixture of one volume of hydrogen gas and 15 volumes of air. The bubble just floated in the air; required the thickness of the film.

The weight of the volume of air displaced is $\frac{4}{3}\pi r^3 \times 0.001293$ gr., and that of the mixture of gases $\frac{4}{3}\pi r^3 \times 0.001293 \times \frac{15 + 0.0693}{16}$; and the difference of these will equal the weight of the soap-bubble.

This weight is that of a spherical shell, which, since its thickness t is very small, is with sufficient accuracy $4\pi r^2 t s$ in grammes, where s is the specific gravity = 1.1. Hence

$$\frac{4}{3}\pi r^3 \left(0.001293 - 0.001293 \times \frac{15.0693}{16} \right) = 4\pi r^2 t \times 1.1.$$

Dividing each side by $\frac{4}{3}\pi r^2$, and putting $r = 4$, we get

$$4 \times 0.001293 \left(1 - \frac{15.0693}{16} \right) = 3.3 t;$$

whence $t = 0.0009116629$ cm. = 911.7 micro-millimetres.

19. In a vessel whose capacity is 3 litres, there are introduced 2 litres of hydrogen under the pressure of 5 atmospheres; 3 litres of nitrogen under the pressure of half an atmosphere, and 4 litres of carbonic acid under the pressure of 4 atmospheres. What is the final pressure of the gas, the temperature being supposed constant during the experiment?

The pressure of the hydrogen will be $\frac{2 \times 5}{3}$, that of the nitrogen will remain unchanged, and that of the carbonic acid will be $\frac{4 \times 4}{3}$. Hence, by Dalton's law, the total pressure will be

$$\frac{10}{3} + \frac{1}{2} + \frac{16}{3} = 9\frac{1}{2} \text{ atmospheres.}$$

20. In a barometer which is immersed in a deep bath the mercury stands 743 mm. above the level of the bath. The tube is lowered until the barometric space, which contains air, is reduced to one-third, and the mercury is then at a height of 701 mm. Required the atmospheric pressure at the time of observation. *Ans.* = 764 mm.

21. What is the pressure on the piston of a steam boiler of 8 decimetres diameter if the pressure in the boiler is 3 atmospheres? *Ans.* 10385·85 kilos.

22. What is the pressure of the atmosphere at that height at which an ascent of 21 metres corresponds to a diminution of 1 mm. in the barometric height? *Ans.* 378·9 mm.

23. What would be the height of the atmosphere if its density were everywhere uniform? *Ans.* 7954·1 metres, or nearly 5 miles

24. How high must we ascend at the sea-level to produce a depression of 1 mm. in the height of the barometer?

Ans. Taking mercury as 10,500 times as heavy as air, the height will be 10·5 metres.

25. Mercury is poured into a barometer tube so that it contains 15 cc. of air under the ordinary atmospheric pressure. The tube is inverted in a mercury bath and the air then occupies a space of 25 cc., the mercury occupying a height of 302 mm. What is the pressure of the atmosphere?

Let x be the required pressure, the air in the upper part of the tube will have a pressure represented by $\frac{15x}{25}$, and this, together with the height of the mercurial column 302, will be the pressure exerted in the interior of the tube on the level of the mercury in the bath, which is equal to the atmospheric pressure; that is $\frac{15x}{25} + 302 = x$, from which $x = 755$ mm.

26. What force is necessary to support a cylindrical bell-jar full of mercury immersed in mercury; its internal diameter being 6 cm., its height ob above the surface of the mercury (fig. 1) 18 cm., and the pressure of the atmosphere 77 cm.?

The downward force on the bell-jar is equal to that of a column of mercury the section of whose base is cd , and the height that of the barometer. This pressure is equal to

$$\pi R^2 \times 77 \times 13\cdot6.$$

The pressure on the inside is that of the atmosphere less the weight of a column of mercury whose base is cd and height ob . This is equal to $\pi R^2 \times (77 - 18) \times 13\cdot6$, and the force required is the difference of these two forces. Making $R = 3$ cm., this is found to be 6·9 kilos.

27. A barometer is placed within a tube which is afterwards hermetically closed. At the moment of closing, the temperature is 15° and the pressure 750 mm. The external space is then heated to 30°. What will be the height of the barometer?

The effect of the increase of temperature would be to raise the mercury in the tube in the ratio $1 + \frac{30}{5550}$ to $1 + \frac{15}{5550}$, and the height h would therefore be

$$= \frac{75 \left(1 + \frac{30}{5550} \right)}{1 + \frac{15}{5550}}$$

and since in the closed space the pressure of the air increases in the ratio $1 + 30a : 1 + 15a$, we shall have finally $h = 301\cdot74$ mm.

28. The heights of two barometers A and B have been observed, at -10° and $+15^\circ$ respectively, to be $A = 737$ and $B = 763$. Required their corrected heights at 0° . *Ans.* $A = 738\cdot33$. $B = 760\cdot94$.



Fig. 1

29. An electric current gives in an hour 840 cubic centimetres of detonating gas under a pressure of 760 and at the temperature $12^{\circ}5$; a second current gives in the same time 960 cubic centimetres under a pressure of 755 and at the temperature $15^{\circ}5$. Compare the quantities of gas given by the two currents. *Ans.* 1 : 1.129.



Fig. 2

The specific gravity of sea-water being 1.026, the depth of 100 metres will represent a column of pure water 102.6 metres in height. As the pressure of an atmosphere is equal to a pressure of 10.33 metres of pure water, the pressure of this column

$$= \frac{102.68}{10.33} = 9.94 \text{ atm.}$$

Hence, adding the atmospheric pressure, the bladder is now under a pressure of 10.94 atmospheres, and its volume being inversely as the pressure will be $\frac{2}{10.94} = 0.183$ litre, if the temperature is unaltered. But the temperature is increased by 4° , and therefore the volume is increased in the ratio 277 to 273, and becomes

$$0.183 \times \frac{277}{273} = 0.18568 \text{ litre.}$$

32. To what height will water be raised in the tube of a pump by the first stroke of the piston, the length of stroke of which is 0.5 m., the height of the tube 6 m., and its section $\frac{1}{10}$ that of the piston? At starting the air in the tube is under a pressure of 10 m.

If we take the section of the tube as unity, that of the body of the pump is 10; and the volumes of the tube and of the body of the pump are in the ratio of 6 to 5. Then if x is the height to which the water is raised in the pipe, the volumes of air in the pump before and after the working of the pump are 6 at the pressure 10, and $5 + 6 - x$ at the pressure $10 - x$.

Forming an equation from these terms, and solving, we have two values, $x' = 18.26$ and $x'' = 2.74$. The first of these must be rejected as being physically impossible; and the true height is $x = 2.74$ metres.

33. A receiver with a capacity of 10 litres contains air under the pressure 76 cm. It is closed by a valve, the section of which is 32 sq. cm., and is weighted with 25 kilos. The temperature of the air is 30° ; its density at 0° and 76 cm. pressure is $\frac{1}{773}$ that of water. The coefficient of expansion of air is 0.00366. Required the weight of air which must be admitted to raise the valve.

The air already present need not be taken into account, as it is under the pressure of the atmosphere. Let x be the pressure in cm. of mercury of that which is admitted, $\frac{x \times 13.6}{1000}$ will represent its pressure in kilos. per sq. cm.; and therefore

the internal pressure on the valve, which is equal to the external pressure of 25 kilos., is $x \times 13.6 \times 32 = 25 \text{ k.}$ From which $x = 57.44$.

For the weight we shall have

$$P = \frac{10 \times 0.001293}{1 + 0.00366 \times 30} \times \frac{57.44}{76.00} = 8.8055 \text{ grammes.}$$

34. A bell-jar contains 3.17 litres of air; a pressure gauge connected with it marks zero when in contact with the air (fig. 3). The jar is closed and the machine worked; the mercury rises to 65 cm. A barometer stands at 76 cm. during the experiment. Required the weight of air withdrawn from the bell-jar and the weight of that which remains.

At 0° and 76 cm. the weight of air in the bell-jar is

$$1.293 \times 3.17 = 4.09881.$$

At 0° and under the pressure 76 - 65 the weight of the residual air is

$$\frac{4.09881 \times 11}{76} = 0.5932,$$

and therefore the weight of that which is withdrawn is

$$4.0988 - 0.5932 = 3.5056 \text{ gr.}$$

35. The capacity of the receiver of an air-pump is 7.53; it is full of air under the ordinary atmospheric pressure and at 0°. Required the weight of air when the pressure is reduced to 0.21; the weight withdrawn by the piston; and the weight which would be left at 15°.

The weight of 7.53 litres of air under the ordinary conditions is 9.736 grammes.

Under a pressure of 0.21 it will be 2.69 grammes, and at the temperature 15° it will

$$\text{be } \frac{2.69}{1 + 0.00366 \times 15} = 0.255 \text{ gramme.}$$

36. In a theoretically perfect air-pump, how great is the rarefaction after 10 strokes, if the volumes of the barrel and the receiver are respectively 2 and 3?

$$\text{Ans.} = 4.59 \text{ mm. ; or about } 1/166 \text{ of an atmosphere.}$$

37. What must be the capacity of the barrel of an air-pump if the density of the air in a receiver of 4 litres is to be reduced to $\frac{1}{3}$ its value in two strokes? *Ans.* 2.9.

38. The reservoir of an air-gun, the capacity of which is 40 cubic inches, contains air whose pressure is 8 times that of the mean atmospheric pressure. A shot is fired when the atmospheric pressure is 741 mm. and the gas which escapes occupies a volume of 80 cubic inches. What is the pressure of the residual air? *Ans.* 6.05 atmospheres.

39. Suppose that at the limit of the atmosphere the pressure of the attenuated air is .001 mm. of mercury and the temperature - 135°, and that in a place at the sea-level, in latitude 45°, the pressure of the atmosphere is 760 mm. and its temperature 15° C. Determine from these data the height of the atmosphere.

From the formula $18400 \left\{ 1 + 0.002 \left\{ T + t \right\} \right\} \log \frac{H}{H_0}$, we get for the height in metres 82,237, which is equal to 51.1 miles.

40. If water is continually flowing through an aperture of 3 square inches with a velocity of 10 feet per second, how many cubic feet will flow out in an hour?

$$\text{Ans. } 750 \text{ cubic feet.}$$

41. With what velocity does water issue from an aperture of 3 square inches, if 37.5 cubic feet flow out every minute?

$$\text{Ans. } 30 \text{ ft./sec.}$$

42. What is the ratio of the pressure in the above two cases?

$$\text{Ans. } 1 : 9.$$

43. What is the theoretical velocity of water from an aperture which is 9 feet below the surface of water?

$$\text{Ans. } 24 \text{ ft. sec.}$$

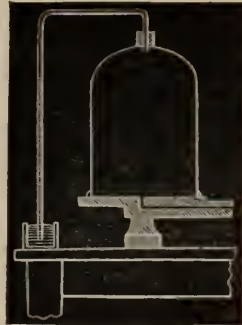

Fig. 3

44. In a cylinder, water stands 2 feet above the aperture and is loaded by a piston which presses with a force of 6 pounds on the square inch. Required the velocity of the effluent water.
Ans. 32 ft./sec.

45. How deep must the aperture of the longer leg of a siphon, which has a section of 4 sq. cm., be below the surface of the water in order that 25 litres may flow out in a minute?
Ans. 5.535 cm.

46. Through a *circular* aperture having an area of 0.196 sq. cm. in the bottom of a reservoir of water which was kept at a constant level, 55 cm. above the bottom, it was found that 98.5 grammes of water flowed in 22 seconds. Required the coefficient of efflux.

Since the velocity of efflux through an aperture in the bottom of a vessel is given by the formula $v = \sqrt{2gh}$, it will readily be seen that the weight in grammes of water which flows in a given time, t , will be given by the formula $w = a a t \sqrt{2gh}$, where a is the area in sq. cm., a the coefficient of efflux, t the time in seconds, and h the height in cm. Hence in this case $a = 0.699$.

47. Similarly through a *square* aperture, the area of which was almost exactly the same as the above, and at the same depth, 104.4 grammes flowed out in 21.6 seconds. In this case $a = 0.73$.

III. SOUND

1. A stone is dropped into a well, and 4 seconds afterwards the report of its striking the water is heard. Required the depth, knowing that the temperature of the air in the well was $10^{\circ}74$.

From the formula $v = 333 \sqrt{1 + at}$ we get for the velocity of sound at the temperature in question 339.05 metres.

Let t be the time which the stone occupies in falling; then $\frac{1}{2}gt^2 = x$ will represent the depth of the well; on the other hand, the time occupied by the report will be $4 - t$, and the distance will be $(4 - t)v = x$ (i); thus $(4 - t)v = \frac{1}{2}gt^2$ (ii), from which, substituting the values,

$$(4 - t) 339.5 = 4.9 t^2$$

$t = 3.793$ seconds, and substituting this value in either of the equations (i) or (ii), we have the depth = 72.6 metres nearly.

2. A bullet is fired from a rifle with a velocity of 414 metres per sec., and is heard to strike a target 4 seconds afterwards. Required the distance of the target from the marksman, the temperature being assumed to be zero.

$$\frac{x}{414} + \frac{x}{333} = 4; x = 738.2 \text{ metres.}$$

3. At what distance is an observer from an echo which repeats a sound after 3 seconds, the temperature of the air being 10° ?

In these 3 seconds the sound traverses a distance of $3 \times 339 = 1017$ metres; this distance is twice that between the observer and the reflecting surface; hence the distance is

$$\frac{1017}{2} = 508.5 \text{ metres.}$$

4. Between a flash of lightning and the moment at which the corresponding thunder is first heard, the interval is the same as that between two beats of the pulse. Knowing that the pulse makes 80 beats in a minute, and assuming the temperature of the air to be 15°C. , what is the distance of the discharge? *Ans.* 454.1 metres.

5. A locomotive passing an observer at the rate of 80 miles an hour is sounding its whistle, the frequency of which is 600. The velocity of sound in air being 1120 ft./sec., determine the change of pitch observed.

Ans. From 694 to 506, a little more than 'a fourth.'

6. What is the velocity of sound in coal gas at 0° , the density being 0.5?

Ans. 470.9 metres per sec.

7. What must be the temperature of air in order that sound may travel in it with the same velocity as in hydrogen at 0° ?

Ans. About 3680°C.

8. What must be the temperature of air in order that the velocity of sound may be the same as in carbonic acid at 0° ?

Ans. $-105^{\circ}5 \text{C.}$

9. Kendall, in a North Pole Expedition, found the velocity of sound at -40° was 314 m. How closely does this agree with that calculated from the value we have assumed for 0° ?

Ans. 6.64 metres too much.

10. What is the value in C.G.S. units of Young's modulus of elasticity for a metal of which the density is 7.5, and in which sound travels with a velocity of 5600 m./sec.?

Ans. 2.352×10^{11} .

11. If a bell is struck immediately at the level of the sea, and its sound, reflected from the bottom, is heard 3 seconds after, what is the depth of the sea?

Ans. 7140 feet.

12. What is the length of the sound wave in air at 0° produced by a siren having 12 apertures and rotating 1660 times per minute? Velocity of sound in air at 0° is 332 m./sec. *Ans.* 1 metre.

13. A siren with 15 holes in the disc gives 150 beats per minute, with a given organ pipe when the disc makes 2000 revolutions per minute, and 90 beats per minute when the disc makes 2016 revs./min. What is the frequency of the organ pipe? *Ans.* 502.5 vibrations per second.

14. A person stands 150 feet on one side of the line of fire of a rifle range 450 feet in length and at right angles to a point 150 feet in front of the target. What is the mean velocity of the bullet if the person hears it strike the target $\frac{1}{9}$ of a second later than the report of the gun? The temperature is assumed to be $16^\circ.5$. *Ans.* 2038 ft./sec.

15. An echo repeats five syllables, each of which requires a quarter of a second to pronounce, and half a second elapses between the time the last syllable is heard and the first syllable is repeated. What is the distance of the echo, the temperature of the air being 10° C. ? *Ans.* 297.47 metres.

16. The note given by a silver wire a millimetre in diameter and a metre in length being the middle C, what is the tension of the wire? Density of silver 10.47. *Ans.* 22.67 kilos.

17. The density of iron being 7.8 and that of copper 8.8, what must be the thickness of wires of these materials, of the same length and equally stretched, so that they may give the same note?

From the formula for the transverse vibration of strings we have for the number of vibrations $n = \frac{1}{rl} \sqrt{\frac{P}{\pi d}}$. As in the present case, the tensions, the length of the strings, and the number of vibrations are the same, we have

$$\frac{1}{rl} \sqrt{\frac{P}{\pi d}} = \frac{1}{r_1 l} \sqrt{\frac{P}{\pi d_1}}, \text{ whence } \frac{r}{r_1} = \sqrt{\frac{8.8}{7.8}} = 1.062.$$

18. A wire stretched by a weight of 13 kilos. sounds a certain note. What must be the stretching weight to produce the major third above this note?

The major third having $\frac{5}{4}$ the number of vibrations of the fundamental note, and as, all other things being the same, the numbers of vibrations are directly as the square roots of the stretching weight, we shall have $x = 20.312$ kilos.

19. The diameters of two wires of the same length and material are 1.5 and 3.8 mm.; and their stretching weights 6 and 24 kilos. respectively. Required the ratio of the numbers of their vibrations. *Ans.* $n : n_1 = 1.266 : 1$.

20. A brass wire 1 metre in length stretched by a weight of 2 kilos., and a silver wire of the same diameter, but 3.165 metres in length, give the same number of vibrations. What is the stretching weight in the latter case? *Ans.* $w = 25$ kilos.

21. Four strings of the same length and material, but of different thicknesses, are stretched on a violin and tuned to give successive fifths. If the tensions are the same, compare the thicknesses of the strings. *Ans.* 27 : 18 : 12 : 8.

22. In the last question what must be the relative tensions on the strings that they may all give the same note? *Ans.* 11.39 : 5.06 : 2.25 : 1.

23. A copper wire 1.25 mm. in diameter and a platinum one of 0.75 mm. are stretched by equal weights. What is the ratio of their lengths, if, when the copper wire gives the note C, the platinum gives F on the diatonic scale?

Ans. The length of the copper is to the length of the platinum = 1.264 : 1.

24. An organ pipe gives the note C at a temperature 0° ; at what temperature will it yield the major third above this note? *Ans.* 153° C.

25. A brass wire a metre in length, and stretched by a weight of a kilo., yields

the same note as a silver wire of the same diameter but 2.5 metres in length and stretched by a weight of 7.5 kilos. Required the specific gravity of the silver.

Ans. 10.068.

26. How many beats are produced in a second by two notes whose rates of vibration are respectively 340 and 354?

Ans. 14.

27. Two weights, A and B, are attached to two strings, the lengths of which are on the ratio 9 : 10, but which are otherwise similar. When the weights are exchanged the number of beats heard when the two strings give their fundamental notes is 3 times as great as before. Find the ratio of the weights.

Ans. A : B = 9 : 10.

IV. HEAT

1. Two mercurial thermometers are constructed of the same glass; the internal diameter of one of the bulbs is 7.5 mm. and of its tube 2.5; the bulb of the other is 6.2 in diameter and its tube 1.5. What is the ratio of the length of a degree of the first thermometer to a degree of the second?

Let A and B be the two thermometers, D and D' the diameters of the bulbs, and d and d' the diameters of the tubes. Let us imagine a third thermometer C with the same bulb as B and the same tube as A , and let l , l' , and l'' denote the length of a degree in each of the thermometers respectively. Since the stems of A and C have the equal diameters, the lengths l and l'' are directly as the volumes of the bulbs, or, what is the same, as the cubes of their diameters; and as B and C have the same bulb, the lengths l' and l'' are inversely proportionate to the sections of the stems, or, what amounts to the same, to the squares of their diameters. We have then

$$\frac{l}{l'} = \frac{D^3}{D'^3} \text{ and } \frac{l'}{l''} = \frac{d'^2}{d^2};$$

introducing the values and solving, we have

$$\frac{l}{l''} = 0.638.$$

2. At what temperature is the number on the Centigrade and Fahrenheit thermometers the same?
Ans. — 40°.

3. The same question for the Fahrenheit and Réaumur scales.
Ans. — 25.6.

4. A capillary tube is divided into 180 parts of equal capacity, the mercury in 25 of which weighs 1.2 gramme. What must be the radius of a spherical bulb to be blown to it so that 180 divisions correspond to 150 degrees Centigrade?

Since 25 divisions of the tube contain 1.2 gramme, 180 divisions contain $\frac{1.2 \times 180}{25} = 8.64$.

And since these 180 divisions are to represent 150 degrees, the weight of mercury corresponding to a single degree is $\frac{8.64}{150}$. But as the expansion corresponding to one degree is only the apparent expansion of mercury in glass, the weight $\frac{8.64}{150}$ is $\frac{1}{6480}$ of the mercury in the reservoir, which is $\frac{4}{3} \pi R^3$. From this $R = 1.8755$ centimetre.

5. By how much is the circumference of an iron wheel, whose diameter is 6 feet, increased when its temperature is raised 400 degrees? Coefficient of expansion of iron = 0.000122.
Ans. By 0.092 foot.

6. What must be the length of a wire of this metal which for a rise of temperature of 1° expands by one foot?
Ans. 81967 feet.

7. Two walls, which when perpendicular are 30 feet apart, have bulged outwards to the extent of 2.4 inches. They are to be made perpendicular by the contraction of an iron bar. By how much must its temperature be raised above that of the air, which is taken at 0°?
Ans. 546.4.

8. An iron wire 4 sq. mm. in cross section is stretched $\frac{1}{81200}$ of its length by a



Fig. 4

weight of 1 kilo. What weight must be applied to a bar 9 sq. mm. in cross section, when it is heated from 0° to 20° , in order to prevent it from expanding?

Ans. 44·5 kilos.

9. If the coefficient of apparent expansion of mercury in glass is $\frac{1}{8500}$, what mass of mercury will overflow from a weight thermometer which contains 400 grs. of mercury at 0° C., when its temperature is raised to 100° .

Ans. 6·061 grs.

10. A bottle holds when quite full at the temperature of melting ice 20 cubic inches of ice-cold water. How many cubic inches of boiling water will it hold, the bottle as well as the water being at 100° C.? Coefficient of linear expansion of glass is 9×10^{-6} .

Ans. 20·054.

11. At the temperature zero a solid is immersed 0·975 of its total volume in alcohol. At the temperature 25° the solid is wholly immersed. The coefficient of expansion of the solid being 0·000026, required the coefficient of expansion of the alcohol.

Ans. 0·001052.

12. Into a glass globe, the capacity of which at 0° is 250 cc., are introduced 25 cc. of air measured at 0° and 76 cm. The flask being closed and heated to 100° , required the internal pressure. Coefficient of cubical expansion of glass $\frac{1}{38700}$.

At 100° the capacity of the flask is 250 $\left(1 + \frac{100}{38700}\right)$; again at 100° the volume of the free air under the pressure 76 is 25 $(1 + 100 \times 0\cdot00366)$. But its real volume is $250 \times \frac{388}{387}$ under a pressure x . Hence

$$76 : x = 250 \times \frac{388}{387} : 25 \times 1\cdot366, \text{ from which } x = 10\cdot3548 \text{ cm.}$$

13. The specific gravity of mercury at 0° being 13·6, required the volume of 3 kilogrammes at 85° . Coefficient of expansion 0·0018.

Ans. 224 cc.

14. A hollow copper sphere 20 cm. in diameter is filled with air at 0° under a pressure of $1\frac{1}{2}$ atmosphere; what is the total pressure on the interior surface when the enclosed air is heated to a temperature of 600° ?

Ans. 6226·5 kilos.

15. Calculate the weight of air in a room $20 \times 10 \times 2$ metres when the barometer stands at 77 cm. and the Centigrade thermometer at 15° . If the barometer was at 42 cm. and the thermometer at 25° , what weight of air would it contain? Given that 0·01293 gr. of air at 0° and 76 cm. has a volume of 1 cc.

Ans. 499·1 kilos. ; 263 kilos.

16. Between the limits of pressure 700 to 780 mm. the boiling-point of water varies $0\cdot0375$ C. for each mm. of pressure. Between what limits of temperature does the boiling point vary when the height of the barometer is between 735 and 755 mm.?

Ans. Between $99\cdot0625$ and $99\cdot8125$.

17. Liquid phosphorus cooled down to 30° is made to solidify at this temperature. Required to know if the solidification will be complete, and if not, what weight will remain melted? The melting point of phosphorus is $44\cdot2$; its latent heat of fusion 5·4, and its specific heat 0·2.

Let x be the weight of phosphorus which solidifies; in so doing it will give out a quantity of heat = $5\cdot4 x$; this is expended in raising the whole weight of the phosphorus from 30 to $44\cdot2$. Hence we have $5\cdot4 x = 1 \times (44\cdot2 - 30) 0\cdot2$, from which $x = \frac{2\cdot84}{5\cdot4} = 0\cdot526$, so that 0·474 of phosphorus will remain liquid.

18. A pound of ice at 0° is placed in two pounds of water at 0° ; required the weight of steam at 100° which will melt the ice and raise the temperature of the mixture to 30° . The latent heat of the liquefaction of ice is 79·2, and that of the vaporisation of water 536.

Ans. 279 pound.

19. 65·5 grammes of ice at -20° having been placed in x grammes of oil of

turpentine at 13.3° , the final temperature is found to be 3.1° . The specific heat of turpentine is 0.4 , and it is contained in a vessel, weighing 25 grammes, whose specific heat is 0.1 . The specific heat of ice is 0.5 . Required the value of x .

Ans. $x = 1475$ grammes.

20. In what proportion must water at a temperature of 30° and linseed oil (sp. heat = 0.5) at a temperature of 50° be mixed so that there are 20 kilos. of the mixture at 40° ?

Ans. Water = 6.66 kilos. and linseed oil = 13.34 .

21. By how much will mercury at 0° be raised by an equal volume of water at 100° ?

Ans. $68^{\circ}.9$ C.

22. The specific heat of gold being 0.03244 , what weight of it at 45° will raise a kilogramme of water from $12^{\circ}.3$ to $15^{\circ}.7$?

Let x be the weight sought; then x kilogrammes of gold in sinking from 45° to $15^{\circ}.7$ will give out a quantity of heat represented by $x(45^{\circ} - 15^{\circ}.7)0.03244$, and this is equal to the heat gained by the water, that is to $1(15^{\circ}.7 - 12^{\circ}.3) = 3.4$, hence $x = 3.58$.

23. The specific heat of copper sulphide is 0.1212 , and that of silver sulphide 0.0746 . 5 kilos. of a mixture of these two bodies at 40° , when immersed in 6 kilos. of water at 7.669° , raises its temperature to 10° . How much of each sulphide did the mixture contain?

The weight of the copper sulphide = 2 , and that of the silver sulphide 3 .

24. Into a mass of water at 0° , 100 grammes of ice at -12° are introduced; a weight of 7.2 grammes of water at 0° freezes about the lump immersed, while its temperature rises to zero. Required the specific heat of ice. Latent heat of water = 79.2 .

Ans. 0.4752 .

25. Four pounds of copper filings at 130° are placed in 20 pounds of water at 20° , the temperature of which is thereby raised 2 degrees. What is the specific heat, c , of copper?

Ans. $c = 0.0926$.

26. Two pieces of the same metal, weighing 300 and 350 grammes, heated to a temperature x , have been immersed, the former in 3351.6 grammes of water at 10° , and the latter in 1935.4 grammes at the same temperature. The temperature in the first case rises to 20° , and in the second to 30° . Required the original temperature and the specific heat of the metal. *Ans.* x the temperature = 1000° ; c the specific heat = 0.114 .

27. In what proportions must a kilogramme of water at 50° be divided in order that the heat which one portion gives out in cooling to ice at zero may be sufficient to change the other into steam at 100° ?

Ans. $8203 : 1797$.

28. Three mixtures are formed by mixing two and two together, equal quantities of ice, salt, and water at 0° . Which of these mixtures will have the highest and which the lowest temperature? *Ans.* The mixture of ice and salt will produce the lowest temperature, while that of ice and water will produce no lowering of temperature.

29. In 25.45 kilos. of water at $12^{\circ}.5$ are placed 6.17 kilos. of a body at a temperature of 80° ; the mixture acquires the temperature $14^{\circ}.1$. Required the specific heat of the body.

If c is the specific heat required, then $mc(t' - \theta)$ represents the heat lost by the body in cooling from 80° to $14^{\circ}.1$; and that absorbed by the water in rising from $12^{\circ}.5$ to $14^{\circ}.1$ is $m'(\theta - t)$. These two values are equal. Substituting the numbers, we have $c = 0.10014$.

30. Assuming that 1 gr. of water expands by $.09$ c.c. on freezing and evolves 80 calories, determine the specific heat of a substance 10 gr. of which when introduced into a Bunsen's calorimeter at a temperature of 100° C. produce a contraction of 70 cubic mmi.

Ans. $.062$

31. Equal lengths of the same thin wire traversed by the same electric current are placed respectively in 1 kilo. of water and in 3 kilos. of mercury. The water is raised 10° in temperature; by how much will the mercury be raised?

Ans. $100^{\circ}.04$.

32. How many cubic feet of air under constant pressure are heated through 1°C . by one thermal unit? *Ans.* 55.3 cubic feet.

33. Given two pieces of metal, one x weighing 2 kilos, heated to 80° , and the other y weighing 3 kilos., and at the temperature 50° . To determine their specific heats they are immersed in a kilogramme of water at 10° , which is thereby raised to $26^{\circ}3$.

The experiment is repeated, the two metals being at the temperature 100° and 40° respectively, and, as before, they are placed in a kilogramme of water at 10° , which this time is raised to $28^{\circ}4$. Required the specific heats of the two metals.

$$\text{Ans. } x = 0.115; y = 0.0555.$$

34. For high temperatures the specific heat of iron is $0.1053 + 0.000017 t$. What is the temperature of a red-hot iron ball weighing a kilogramme, which, plunged in 16 kilogrammes of water, raises its temperature from 12° to 24° ? What was the temperature of the iron?

$$(0.1053 + 0.000017 t) (t - 24) = 16 (24 - 12),$$

$$\text{or } 0.000017 t^2 + 1.048892 t - 2.5272 = 192;$$

$$\text{whence } t = 1493.3^{\circ}\text{C}.$$

35. A kilogramme of the vapour of alcohol at 80° passes through a copper worm placed in 10.8 kilogrammes of water at 12° , the temperature of which is thereby raised to 36° . The copper worm and copper vessel in which the water is contained weigh together 3 kilogrammes. Required the latent heat of alcohol vapour. *Ans.* 238.77.

36. Determine the temperature of combustion of charcoal in burning to form carbonic acid.

We know from chemistry that one part by weight of carbon in burning unites with $2\frac{3}{8}$ parts by weight of oxygen to form $3\frac{3}{8}$ parts by weight of carbonic acid. Again the number of thermal units produced by the combustion of a pound of charcoal is 8080; the whole of this heat is contained in the $3\frac{3}{8}$ parts of carbonic acid produced, and if its specific heat were the same as that of water, its temperature would be

$$\frac{8080}{3\frac{3}{8}} = 2204^{\circ}\text{C}.; \text{ but since the specific heat of carbonic acid is } 0.2163 \text{ that of an equal}$$

$$\text{weight of water, the temperature will be } \frac{2204}{0.2163} = 10189^{\circ}\text{C}.$$

37. A glass globe measuring 60 cubic centimetres is found to weigh 19.515 grammes when filled with air under a pressure of 752.3 mm. and at a temperature of 10°C . Some ether is introduced and vaporised at a temperature of 60° , whereupon the flask is sealed while quite full of vapour, the pressure being 753.4 mm. Its weight is now found to be 19.6025 grammes. Required the density of the ether vapour compared with that of hydrogen. *Ans.* 37.

38. Calculate the density of alcohol vapour as compared with air by Gay-Lussac's method from the following data:—

Weight of alcohol 0.1047 gr.; vol. of vapour at 110°C . = 82.55 cc.; height of mercury above the level in the bath, 98 mm.; barometric height, 752.3 mm.; temperature of the room, 15°C . *Ans.* 1.6.

39. In a determination of the vapour density by Gay-Lussac's method, 0.1163 gramme of substance was employed. The volume observed was 50.79 cc., the height of the mercury above the level of that in the bath was 80.0 mm, the height of the oil column reduced to millimetres of mercury 16.9; the temperature 215°C ., and the height of the barometer at the time of observation 755.5 mm. Required the specific gravity of the vapour as compared with that of hydrogen. *Ans.* 50.1.

40. Through a U-tube containing pumice saturated with sulphuric acid a cubic metre of air at 15° is passed, and the tube is found to weigh 3.95 grammes more. Required the hygrometric state of the air.

The pressure of aqueous vapour at 15° is 12.699 mm.; hence the weight of a cubic metre of aqueous vapour saturated at 15° is $\frac{1293 \times 12.699 \times 5}{\left(1 + \frac{15}{273}\right) 760 \times 8} = 12.79$ grammes,

and the hygrometric state is $\frac{3.95}{12.79} = 0.309$.

41. A quantity of dry air measures $4,500$ cc. at 10° C., and 760 mm. pressure. If the air is heated to 33° and saturated with vapour at that temperature, find the volume of the mass of air in order that the pressure may be doubled, the pressure of aqueous vapour at 33° being 37.41 mm. *Ans.* 2493 cc.

42. The quantity of water given out by the lungs and skin may be taken at 30 ounces in 24 hours. How many cubic inches of air already half saturated at 10° will be fully saturated by the moisture exhaled from the above two sources by one man? Pressure of aqueous vapour at 10° in inches = 0.361 . Pressure of the atmosphere = 30 inches. *Ans.* 6121 cubic feet.

43. A mass of air extending over an area of $60,000$ square metres to a height of 300 metres has the dew point at 15° , its temperature being 20° . How much rain will fall if the temperature sinks to 10° ?

The weight of vapour condensed from one cubic metre in these circumstances will be 3.1435 grammes, and therefore from $18,000,000$ cubic metres it will be $56,583$ kilogrammes, which is equal to a rainfall 0.0943 mm. in depth.

44. When 3 cubic metres of air at 10° and 5 cubic metres at 18° , each saturated with aqueous vapour at those temperatures, are mixed together, is any water precipitated? And if so, how much?

The weight of water contained in the two masses under the given conditions are respectively 28.18 and 76.59 grammes; the weight required to saturate the mixture at the temperature of 15° is 102.39 grammes, and therefore 2.38 grammes will be precipitated.

45. The temperature of the air at sunset being 10° , what must be the lowest hygrometric state, in order that dew may be deposited, it being assumed that in consequence of nocturnal radiation the temperature of the ground is 7° below that of the air? *Ans.* The hygrometric state must be at least 0.62 of total saturation.

46. It is stated as a practical rule that when the pressure of aqueous vapour present in the atmosphere, as indicated by the dew point, is equal to x mm. of mercury, the weight of water present in a cubic metre of that air is x grammes. What is the error in this statement for a pressure of 10 mm. and the temperature 15° C.?

Ans. 0.172 gr.

47. A mass of 1 kilo. is moving with a velocity of 500 ft. per second. What is its energy in calories? *Ans.* 2751 .

48. A raindrop falls to the ground from a height of a mile; by how much would its temperature be raised, assuming that it imparts no heat to the air or to the ground? *Ans.* $3^{\circ}.8$ C.

49. A lead bullet falls through a height of 10 metres; by what amount will its temperature have been raised when it reaches the ground, if all the heat is expended in raising the temperature of the bullet? *Ans.* 0.7515° C.

50. Determine the value of the mechanical equivalent of heat from the following data. Specific heat of air at constant pressure = $.2374$; velocity of sound in air at 0° = 333 m./sec; density of air at 0° and 760 mm. = $.001293$; $g = 981$; density of mercury at 0° = 13.6 ; coefficient of expansion of air = $1/273$.

Ans. 4.135×10^7 .

51. From what height must a lead bullet fall in order that its temperature may be raised n degrees?—and what velocity will it have acquired? It is assumed that all the heat is expended in raising the temperature of the bullet; the specific heat of lead is 0.0314 , and Joule's equivalent 424 , a metre being the unit of length.

Ans. $13.31 \times n$ metres; $v = 28.8 \sqrt{n}$ metres per second.

52. How much heat is disengaged if a bullet weighing 50 grammes and having a velocity of 50 metres strikes a target?

Ans. Sufficient to raise one gramme of water through 15° C.

53. How much heat is produced in the room of a manufactory in which 1.2 horse-power of the motor is consumed each second in overcoming the resistance of friction?

Ans. A quantity sufficient to raise 102561 pounds of water one degree Centigrade.

54. What is the ratio between the quantities of heat which are respectively produced when a bullet weighing 50 grammes and having a velocity of 500 metres, and a cannon-ball weighing 40 kilogrammes with a velocity of 400 metres, strike a target?

Ans. 1 : 512.

55. The specific heat of lead is 0.031 , and its latent heat of fusion 5.37 . What is the mechanical equivalent of the heat necessary to raise 5 pounds of lead from a temperature of 270° C. to its melting-point 335° C., and then to melt it?

Ans. 51326 foot-pounds.

56. Assuming that the temperature at which heat leaves a perfect engine is 16° C., at what temperature must it be taken in in order to obtain a theoretical useful effect of $\frac{1}{3}$?

Ans. 160.5° C.

57. Assuming that in a perfect engine heat is taken in at a temperature of 144° , and is given out at a temperature of 36° : what is the greatest theoretical useful effect?

Ans. 0.259 :

58. How many calories will be conducted in an hour through each square metre of an iron plate 3 cm. thick, its two sides being kept at the respective temperatures of 20° and 200° , the mean specific conductivity of iron between these temperatures being 0.12 ?

Ans. 21,600.

V. LIGHT

1. How many candles are required to produce at a distance of 2.5 metres the same illuminating effect as one candle at a distance of 0.45 metre? *Ans.* 31.
2. Two sources of light whose intensities are as 1 : 2 are 2 metres apart. At what position is a space between them equally illuminated?
Ans. 0.828 metre from the less intense light.
3. A candle sends its rays vertically against a plane surface. When the candle is removed to thrice the distance and the surface makes an angle of 60° with the original position, what is the ratio of the illuminations in the two cases? *Ans.* 18 : 1.
4. An observer, whose eye is 6 feet above the ground, stands at a distance of 18 feet from the near edge of a still pond, and sees there the image of the top of a tree, the base of which is at a distance of 100 yards from the place at which the image is formed. Required the height of the tree. *Ans.* 100 feet.
5. What is the height of a tower which casts a shadow 56.4 metres in length when a vertical rod 0.95 metre in height produces a shadow 1.38 metre in length?
Ans. 38.8.
6. A minute hole is made in the shutter of a dark room, and at a distance of 2.5 metres a screen is held. What is the size of the image of a tree which is 15.3 metres high and is at a distance of 40 metres? *Ans.* 95.625 cm.
7. What is the length of the shadow of a tree 50 feet high when the sun is 30° above the horizon? What when it is 45° , and 60° ? *Ans.* 86.6; 50, and 28.867 feet.
8. Under what visual angle does a line of 30 feet appear at a distance of 18 feet.
Ans. $79^\circ 36'$.
9. The apparent diameter of the moon amounts to $31' 3''$. What is its real diameter if its distance from the earth is taken at 239000 geographical miles?
Ans. 2158 geographical miles.
10. What must be the angle between two plane mirrors in order that an incident ray which is parallel to one of them may after two reflections be parallel to the other?
Ans. 60° .
11. For an ordinary eye an object is visible with a moderate illumination and pur-air under a visual angle of 40 seconds. At what distance, therefore, can a black circle (6 inches in diameter) be seen on a white ground? *Ans.* 2578 feet.
12. At what distance from a circle with a diameter of one foot is the visual angle a second? *Ans.* 206265 feet.
13. At what distance would a circular disc 1 inch in diameter, of the same brightness as the sun's surface, illuminate a given object to the same extent as a vertical sun in the tropics, the light absorbed by the air being neglected?
Ans. Taking the sun's angular diameter at 30', $x = 38$ inches.
14. What is the minimum deviation for a glass prism ($n = 1.53$), whose refracting angle is 60° ? *Ans.* $39^\circ 50'$.
15. A ray of monochromatic light is incident at 60° on one face of a prism whose angle is 30° . After refraction at this face and reflection at the second face of the prism the ray returns on its own path. What is the refractive index of the material of the prism? *Ans.* 1.732.
16. What is the minimum deviation for a prism of the same substance when the refracting angle is 45° ? *Ans.* $63^\circ 38'$.
17. The refracting angle of a prism of silicate of lead was found by measurement to be $21^\circ 12'$, and the minimum deviation to be $24^\circ 46'$. Required the refractive index of the substance. *Ans.* 2.122.

18. Construct the path of a ray which falls on an equiangular crown-glass prism at an angle of 30° ; and find its deviation. *Ans.* $70^\circ 45'$.

19. What are the angles of refraction of a ray which passes from air into glass at an angle of 40° ; from air into water at an angle of 65° ; and from air into diamond at an angle of 80° ? *Ans.* $25^\circ 20'$; $44^\circ 5'$; $23^\circ 12'$.

20. The focal length of a concave mirror is 8 metres. What is the distance of the image from the mirror when the object is at a distance of 12, 5, and 7 metres respectively? *Ans.* 24; - 13'3, and - 56.

21. An object at a distance of 10 feet produces a distinct image at a distance of 3 feet. What is the focal length of the mirror? *Ans.* 2'3077 feet.

22. Required the focal length of a crown-glass meniscus lens, the radius of curvature of the concave face being 45 mm., and that of the convex face 30 mm.; the index of refraction being 1'5. *Ans.* $f = 180$ mm.

23. What is the focal length of a double-convex lens of diamond, the radius of curvature of each of whose faces is 4 mm., the refractive index of diamond being 2'487? *Ans.* 1'34 mm.

24. A watch-glass with ground edges, the radius of curvature of which was 4'5 cm., was filled with water, and a glass plate slid over it. The focal length of the plano-convex lens thus formed was found to be 13'5 cm. Required the refractive index of the water. *Ans.* $n = 1'33$.

25. If the refractive index from air to glass is $3/2$, and that from air to water is $4/3$, find the ratio of the focal lengths of a glass lens in water and in air. *Ans.* 4 : 1.

26. What is the focal length of a convex lens when the distances of the image and object are respectively 5 and 36 cm.? *Ans.* 4'4 cm.

27. The radii of curvature of a double-convex lens of crown glass are 6 and 8 inches. What is the focal length? *Ans.* 6'85 inches.

28. A concave lens and a concave mirror having a common axis are 6 inches apart. Rays starting from a point on the axis 12 inches from the lens fall on the lens, then on the mirror, and converge to a point $4\frac{1}{2}$ inches from the mirror. If the radius of curvature of the mirror is 6 inches, what is the focal length of the lens? *Ans.* 5 ft.

29. The focal length of a double-convex lens is 4 inches; the radius of curvature of one of its faces is 3 inches. What is that of the second? *Ans.* 6 inches.

30. If the focal length of a convex lens is 1 cm., at what distance must a luminous object be placed so that its image is formed at 2 cm. distance from the lens? *Ans.* 2 cm.

31. A candle at a distance of 120 cm. from a lens forms an image on the other side of the lens at a distance of 200 cm. Required the nature of the lens and its focal length. *Ans.* It is a convex lens, and its focal length is 75 cm.

32. A plano-convex lens was found to produce at a distance of 62 cm. a sharp image of an infinitely distant object. In front of the same lens, at a distance of 84 cm., a millimetre scale was placed, and a sharp image was formed at a distance of 250 cm. It was thus found that 10 mm. in the object corresponded to 29 in the image. From these observations determine the focal length of the lens. *Ans.* The mean of the results is 62'4.

33. A beam of light is converged by a lens A to a point B, 10 inches from the lens. If a second lens (focal length = 10 inches) is placed symmetrically between A and B, and 8 inches from A, determine the new point of convergence of the beam where the second lens is (1) convex, (2) concave. *Ans.* (1) 9'66, (2) 10'5 inches, from A.

34. The image of a distant tree was sharply formed at a distance of 31 cm. from the centre of a concave mirror.

In another case the image of an object 18 mm. in length at a distance of 405 mm. from the mirror was formed at 1350 mm. from the mirror and had a length of 61 mm. In another experiment the distances of object and image and the size of the image were respectively 2200, 355, and 3 mm.

Deduce from these several data the focal length of the mirror. *Ans.* 31'2 ; 30'5.

35. If the refractive index of crown glass for sodium light is 1'50, and that of flint glass 1'60, find approximately the angle of a flint-glass prism required to correct the deviation produced by a crown-glass prism of 20°. What is the dispersion produced by the two prisms when combined so as to give no deviation between two rays between which the dispersive power of crown glass is 0'04 and of flint glass 0'06?

Ans. 10° ; 0'12.

36. Prove that the magnifying power of a simple telescope consisting of two lenses only (object glass and eyepiece) when focused for parallel rays is equal to the ratio of the diameter of the object glass to the diameter of the image of the object glass formed by the eyepiece.

37. A diffraction grating, with lines 0'05 mm. apart, is held in front of a Bunsen's burner in which common salt is volatilised, and when viewed through a telescope it is found that the angular distances of the first, second, fourth, and sixth bright bands from the central one are respectively 0° 41', 1° 21', 2° 42', and 4° 3'. Required the wave-length of sodium light.

The formula $\lambda = \frac{d \sin \phi}{n}$, where λ is the wave-length, ϕ the angular distance of any bright line of order n from the central one, gives as the mean of the 4 observations :

Ans. 0'00059088 mm.

VI. MAGNETISM

1. A compass needle at the magnetic equator makes 15 oscillations in a minute; how many will it make in a place where the horizontal force of the earth's magnetism is $\frac{16}{25}$ as great? *Ans.* 12.

2. A compass needle makes 9 oscillations a minute under the influence of the earth's magnetism alone; how many will it make when re-magnetised so as to be half as strong again as before? *Ans.* 11.

3. A small compass needle makes 100 oscillations in 7 min. 42 sec. under the influence of the earth's magnetism only; when the south pole of a long bar magnet A is placed 10 inches north of it, it makes 100 oscillations in 4 min. 3 sec.; and with the south pole of another magnet B in the same place, it makes 100 oscillations in 4 min. 48 sec. What are the relative strengths of the poles of the magnets A and B? *Ans.* 1'404 : 1.

4. A horizontal bar magnet makes 100 oscillations in 12'5 minutes at a certain place A. At another place B the same magnet having lost 10 per cent. of its magnetism makes 100 oscillations in 13 minutes. Compare the horizontal forces at A and B. *Ans.* '973 : 1.

5. A small compass needle makes 100 vibrations in 5 min. 36 sec. under the influence of the earth's magnetism only, and 100 in 4 min. 54 sec. when a horizontal bar magnet is placed with its centre vertically below the needle and with its axis on the magnetic meridian. Compare the force exerted upon the needle by the bar magnet with that exerted by the earth. *Ans.* '143 : 1.

6. Find the total magnetic force of the earth at a place where $H = '223$ and the dip is 60° . *Ans.* '446.

7. A dip needle is supported at its centre of gravity and moves in a vertical plane inclined at 45° to the plane of the magnetic meridian. Compare the horizontal and vertical forces acting on the needle with those which would act if the plane of motion were that of the magnetic meridian. *Ans.* $H_1 : H_2 = 1 : \sqrt{2}$; $V_1 = V_2$.

8. At a place where the magnetic dip is 60° , a dip needle makes 10 oscillations per minute when swinging in the plane of the magnetic meridian; find how many oscillations per minute it will make when swinging in the plane perpendicular to the magnetic meridian. *Ans.* 9'305.

9. Compare the work required to twist a magnet through 60° from the meridian with that required to twist it 90° . What is the actual amount of work in either case if the moment of the magnet is 200 and the earth's horizontal field 0'18. *Ans.* $\frac{1}{2}$; 18, 9.

10. A bar magnet lies on a table in a direction perpendicular to the magnetic meridian. In the prolongation of its axis, and at distances 30 and 60 cm. from its centre, are placed small compass needles. Compare the tangents of the deflections of the needles, assuming that they have no influence on each other. *Ans.* 8 : 1.

11. A small compass needle is pivoted on a point fixed to a horizontal table which is movable about a vertical axis. A short bar magnet is now laid on the table, with its centre in, and its length perpendicular to, the magnetic axis of the needle, and the needle is thereby deflected. It is then found that the table must be turned through 30° for the needle to point to the centre of the bar. Show that the magnetic moment of the bar is $\frac{1}{2} Hr^2$ where H = the horizontal force, and r = distance of a pole of the magnet from the needle's centre.

12. A magnet placed due east (magnetic) of a compass needle deflects the needle

through 60° . If at another station where the horizontal force is three times as great, the same magnet is similarly placed with respect to the compass needle, what will be the deflection? *Ans.* 30° .

13. A horizontal magnet is supported by a vertical wire, and is in the magnetic meridian. The top of the wire has to be twisted through 120° in order to deflect the magnet through a right angle. By how much has the top of the wire to be twisted for the needle to be deflected through 30° only? *Ans.* 45° .

14. Two magnets, the moment of one of which is double that of the other, are rigidly connected together, with the centre and axis of one vertically over the centre and axis of the other, and the whole is suspended by a fine metallic wire. When the magnets are oppositely directed, the top end of the wire has to be twisted through 75° in order to deflect the combination 30° from the meridian. By how much must the top end of the wire be twisted when the magnets are similarly directed in order that the combination may take up a position perpendicular to the magnetic meridian? *Ans.* 360° .

15. Two bar magnets whose magnetic moments are as $1.728 : 1$ are placed parallel to each other, with their N. poles pointing in opposite directions and perpendicular to the line A B joining their centres, this line being in the direction of the magnetic meridian. At what point on A B must a compass needle be placed that it may not be deflected by the magnets? *Ans.* If a, b are the distances from the first and second magnets respectively, $a : b = 6 : 5$.

16. Prove that the magnetic force exerted by a short magnet at a point A on the line passing through its centre and perpendicular to its axis is the same as the force exerted at a point on the axis the distance of which from the centre of the magnet is $\sqrt[3]{2}$ times the distance of A from the centre.

17. A long fine iron wire which is magnetised and bent into a horse-shoe with its poles 4 inches apart is suspended by a thread with its poles in a horizontal line. The opposite ends of two very long bar magnets are placed in the same horizontal line on opposite sides of the suspended horse-shoe and at distances of 2 and 3 inches from its nearest poles, but the position of equilibrium of the wire is not thereby disturbed. Show that the pole strengths of the magnets are as 20 : 49.

18. A short bar magnet is placed on a table with its axis perpendicular to the magnetic meridian, and passing through the centre of a compass needle. In London the compass needle is deflected through a certain angle when the centre of the magnet is 25 inches from the centre of the needle. When the experiment is repeated in Bombay the magnet must be moved 5 inches nearer to the needle to produce the same deflection. Use these data to compare the horizontal forces in London and Bombay. *Ans.* $H_1 : H_2 = 1 : 1.95$.

VII. FRICTIONAL ELECTRICITY

1. At one end of a light glass thread, carefully balanced so as to oscillate in a vertical plane, is a pith ball. Over this and in contact with it is a fixed pith ball of the same dimensions. Both balls being charged with the same electricity, it is found that to keep them $1\frac{1}{4}$ inch apart, a weight of $\cdot 9$ mgr. must be placed at the free end of the glass thread. What weight must be placed there to keep the balls $1\cdot 05$ inch apart?

Ans. $1\cdot 6$ mgr.

2. A small insulated sphere A charged with the quantity of + electricity 2 is at a distance of 25 mm. from a second similar sphere B charged with the quantity 5; the latter is momentarily touched with an un electrified sphere B, of the same size, and the distance altered to 20 mm. What is the ratio of the repulsive forces in the two cases?

Ans. $32 : 25$.

3. Two equally charged spheres repel each other when their centres are half a metre apart with a force equal to the weight of 6 mgr. What is the charge on each in electrostatic units?

Ans. $121\cdot 3$.

4. Two insulated spheres of different sizes are charged with positive electricity so that when they are placed at equal distances from, but on opposite sides of, an insulated positively charged pith ball it remains at rest. If the two spheres are put in contact by a long thin wire will the ball move, and if so, in what direction?

5. A short ebonite rod with a small electrified knob at one end is mounted so as to turn freely about its centre in a horizontal plane. In a horizontal line from this, and at a distance from it of 25 and 50 cm. respectively, are placed insulated balls that are also charged. The rod makes 10 vibrations in a given time, but makes 30 vibrations in the same time if the balls are interchanged. Compare the charges on the balls.

Ans. If Q_1 and Q_2 are the charges, $Q_1 : Q_2 = -7 : 1$.

6. Two insulated spheres A and B, whose diameters are respectively as 7 : 10, have equal quantities of electricity imparted to them. In what ratio are their electric densities?

Ans. $100 : 49$.

7. Two such spheres whose diameters are as 3 : 5 contain respectively the quantities of electricity 7 and 10. In what ratio are their densities? *Ans.* $35 : 18$.

8. Can the leaves of an electroscope be made to diverge when they are kept at zero potential? If so, describe how and explain why.

9. Equal quantities of electricity are communicated to two insulated metallic spheres whose radii are as 5 : 1. What are their relative potentials? The spheres are then put in conducting communication by means of a long thin wire which is afterwards removed. What are now the relative surface densities of the two spheres?

Ans. If V_1, V_2 are the potentials and σ_1, σ_2 the densities, $V_1 : V_2 = 1 : 5 = \sigma_1 : \sigma_2$.

10. Two similar and equally sensitive gold-leaf electroscopes, A and B, are connected together by a fine wire. State and explain the behaviour of the electroscopes when (1) a positively charged body is placed near A, (2) the wire connection is removed (by insulating tongs), (3) B is touched, (4) the wire connection is restored.

Ans. In (4) B diverges with + electricity; the divergence of A is increased.

11. Two Leyden jars are exactly alike except that in one the tinfoil coatings are separated by glass, and in the other by ebonite. A charge of electricity is given to the glass jar, and the potential of its inner coating measured. The charge is then shared between the two jars, and the potential falls to $\cdot 6$ of its former value. If the specific inductive capacity of ebonite is 2, what is that of glass? *Ans.* 3.

12. Two spheres whose radii are 5 inches and 1 inch are charged with equal quantities of positive electricity. Which has the higher potential, and which the

higher electric density? How are the potential and density of each sphere modified after they have been allowed for a moment to touch each other?

Ans. Potential of the first is twice, and its density four times as great as that of the second. After contact potential is the same, and density of first twice as great as that of second.

13. A Leyden jar consists of two spherical concentric surfaces of 5 and 6 cm. diameters respectively, the intervening space being filled with air. The outer sphere is uninsulated and the inner is charged with 20 units of electricity. How much work is done when the inner sphere is earthed? *Ans.* 13'33 ergs.

14. An insulated sphere of 2 cm. radius is connected by a long thin wire with another insulated sphere, the radius of which is 6 cm., and which is surrounded by a third sphere of 8 cm. radius concentric with it. The wire which connects the first and second spheres passes through a small hole in the third so as not to touch it. All the spheres are conductors. Calculate the capacity of the connected spheres. *Ans.* 26.

15. Three condensers, each having a capacity C , are charged in parallel to a difference of potential V . What is the difference of potential of the terminal when the charged condensers are arranged in series. *Ans.* $\frac{3}{2}V$.

16. Two equal horizontal discs, A and B, are placed symmetrically one over the other and separated by air, A being insulated and B earthed. When A is charged the plates attract each other. Will the attraction be the same when the space between them is filled with paraffin? *Ans.* The attraction will be diminished. See Arts. 760, 797.

17. Four Leyden jars, whose capacities are 1, 2, 3, 4 respectively, are arranged in series, the inner coating of the first and the outer coating of the last being connected to the electrodes of an influence machine between which sparks pass. Could the effects observed be produced by the aid of a single jar, and if so, what would be its capacity? *Ans.* Yes; 48.

18. Within a spherical vessel of brass 1 cm. thick, the external diameter of which is 14 cm., a brass ball 8 cm. in diameter is hung by a silk thread, so that the centres of the two spheres coincide. If the ball is charged with 36 units of positive electricity, and if the potential of the vessel is 7, what is the potential of the ball? *Ans.* 10.

19. Within a very thin hollow spherical conductor is placed a sphere of the same substance, but insulated from it and concentric with it; their diameters are respectively 16 and 10 cm. The potential of the inner sphere is 9, and the charge on the exterior surface of the spherical conductor is 24. What changes of potential would occur if the inner were to touch the outer sphere? *Ans.* Before contact potentials are 9 and 3; after contact each is 13.

20. The area of one of the coatings of a Leyden jar is 1000 sq. cm., the specific inductive capacity of the glass is 5 and the thickness of the glass 3 mm. What is the radius of a conducting sphere which has the same electric capacity as the Leyden jar. *Ans.* 13'25 in.

21. Three insulated conducting spheres, A, B, and C, whose radii are respectively 1, 2, and 3, are charged with electricity, so that their respective potentials are as 3 : 2 : 1, and are then connected by wires, whose capacity may be neglected. What is the total quantity and potential of the system? *Ans.* $Q = 10$; $V = 1'66$.

22. Supposing each of the spheres discharged separately, what would be the total work they would produce, as compared with that produced by the discharge of the whole system? *Ans.* 30 : 25.

23. If 100 units of work must be done to move an electric charge $Q (= 4)$ from a place where the potential is -10 to another place where the potential is V , what is the value of V ? *Ans.* 15.

21. Two spheres of diameter 6 and 10 cm., placed at a distance from each other, are charged with 8 and 10 units of electricity respectively. They are then connected by a fine wire? What is the loss of energy? *Ans.* 4167 erg.

25. An insulated ice-pail and an insulated brass ball are both charged with positive electricity at a distance from each other, the pail to a high potential, the ball to a low potential. The ball is then brought near to the pail and lowered into it without touching it until the bottom is reached. After contact the ball is removed. Describe the changes of potential, both of ball and pail, (1) before contact, (2) on contact, (3) after removal

26. How much energy is expended in carrying a charge of 50 units of electricity from a place where the potential is 20 to another where it is 30? *Ans.* 500 units.

VIII. VOLTAIC ELECTRICITY

1. A tangent galvanometer offering no appreciable resistance is connected by short thick wires with the poles of a cell, and is deflected 20° . By how much will it be deflected if two exactly similar cells are connected in parallel with the first?

Ans. $47^\circ 30'$.

2. By how much if the three cells are connected in series?

Ans. 20° .

3. Two cells each of 1 ohm resistance are connected in series by a wire the resistance of which is also 1 ohm. If each of these when connected singly by short thick wires to a tangent galvanometer of no appreciable resistance deflects it 25° , how much will the combination deflect it, the connections being made by short thick wires?

Ans. $17^\circ 16'$.

4. A single thermo-electric couple deflects a galvanometer of 100 ohms resistance $0^\circ 30'$; how much will a series of 30 such couples deflect it, the temperature-difference being the same in each case, and the connections being made by short thick wires?

Ans. $14^\circ 40'$.

5. Suppose a sine galvanometer had been used in the last question, and the first reading had been $0^\circ 30'$, what would the second be?

Ans. $15^\circ 10'$.

6. The internal resistance of a cell is half an ohm; a tangent galvanometer of 1 ohm resistance, connected with it by short thick wires, is deflected 15° ; by how much will it be deflected if for one of the thick wires a thin wire of $1\frac{1}{2}$ ohm resistance is substituted?

Ans. $7^\circ 37'$.

7. What will be the deflection if each of the wires is replaced by a thin wire of $1\frac{1}{2}$ ohm resistance?

Ans. $5^\circ 6'$.

8. A cell of one-third of an ohm resistance deflects a tangent galvanometer of unknown resistance 45° , the connection being made by two short thick wires. If a wire of 3 ohms resistance be substituted for one of the short wires the deflection is 30° . What is the resistance of the galvanometer?

Ans. 3.75 ohms.

9. If the resistance of 130 yards of a particular copper wire $\frac{1}{16}$ of an inch in diameter is an ohm, what is the resistance of 8242 yards of copper wire $\frac{1}{12}$ of an inch in diameter?

Ans. 35.66 ohms.

10. Express in ohms the resistance of one mile of copper wire $\frac{1}{4}$ of an inch in diameter of the same quality as that referred to in 9.

Ans. 0.8461.

11. What length of platinum wire 0.05 of an inch in diameter must be taken to get a resistance equal to 1 ohm, the specific resistance of platinum in microhms per cm. cube being 10.9.

Ans. 14.9 metres.

12. 660 yards of iron wire 0.0625 of an inch in diameter have the same electric resistance as a mile of copper wire 0.0416 of an inch in diameter. Find the specific resistance of iron, that of copper being unity.

Ans. 6.02.

13. Two cells the electromotive forces of which are as 2 : 1 are joined up in series with their E.M.F.'s acting in the same direction, and the circuit is completed through a tangent galvanometer the needle of which is deflected through 60° . If one of the cells is reversed, no other change being made, what will be the deflection?

Ans. 30° .

14. A current flows through two tangent galvanometers in series, each of which consists of a single ring of copper, the radius of one ring being 3 times that of the other. In which of the galvanometers will the deflection be greater? If the greater deflection is 60° , what will the smaller be?

Ans. (1) In the smaller; (2) 30° .

15. The coil of a tangent galvanometer is placed at right angles to the magnetic meridian, and a steady current passes through it. The needle when set in vibration makes 5 oscillations in a given time, but only 3 in the same time when the current is reversed. Compare the magnetic force at the centre of the coil due to the current with that due to the earth.

Ans. 8 : 17.

16. Ten exactly similar cells in series produce a deflection of 45° in a tangent galvanometer, the external resistance of the circuit being 10 ohms. If they are arranged five in series and two in parallel, a deflection of $33^\circ 42'$ is produced; find the internal resistance of the cell.

Ans. $\frac{1}{2}$ ohm.

17. Ten exactly similar cells each of $\frac{2}{3}$ of an ohm resistance give, when arranged in 2 series of five each, a current of 2 amperes through a resistance R; but when arranged in 5 series of 2 each the current is 3 amperes. What is R?

Ans. 242 ohm.

18. What arrangement of 6 cells, each of $\frac{2}{3}$ of an ohm resistance, will give the strongest current through an external resistance of 2 ohms?

Ans. Indifferent whether all in series or in two series of five each.

19. What is the best arrangement of 20 cells, each of 0.8 ohm resistance, against an external resistance of 4 ohms?

Ans. 10 cells of 2 each.

20. In a circuit containing a tangent galvanometer and a voltmeter, the current which deflects the galvanometer 45° produces 10.32 cubic centimetres of mixed gas in a minute. The electrodes are put farther apart, and the deflection is now 20° ; find how much gas is now produced per minute.

Ans. 3.757 cc.

21. A battery of 6 cells arranged in two parallel rows, each containing 3 cells in series, is joined up in series with 2 cells, the cells having all the same E.M.F. and resistance, and the circuit is completed by a wire whose resistance is equal to half that of the cells in series. Determine the strength of the current produced in terms of that given by one cell when short-circuited.

Ans. $\frac{2}{3}$.

22. A battery of 12 equal cells in series, screwed up in a box, being suspected of having some of the cells wrongly connected, is put into circuit with a galvanometer and two cells similar to the others. Currents in the ratio of 3 : 2 are obtained according as the introduced cells are arranged with their E.M.F.'s with or against the battery E.M.F. What is the state of the battery?

Ans. One cell is reversed.

23. A coil of 6 turns, each of which is 1 metre in diameter, is placed with its plane in the magnetic meridian. What current will deflect a needle at the centre through 45° , the horizontal force of the earth's magnetism being 0.18.

Ans. 2.4 amperes.

24. If the unit of time is 1 second, and if unit quantity and unit potential are so defined that unit quantity falling through unit potential does 1 foot-pound of work, how much work per second will be required to maintain a current of 10 units through a resistance of 20 units, both measured on the same system?

Ans. 2,000 foot-pounds.

25. Four similar cells are arranged in series. The E.M.F. and internal resistance of each are 1.5 v. and 0.5ω respectively. The terminals of the battery are connected by a wire of 3ω resistance. What is the difference of potential between the poles of one of the cells (1) on open circuit, (2) when the current is glowing?

Ans. (1) 1.5 volt; (2) 0.9 volt.

26. The ends A and B of a thick wire are connected to the poles of a battery, and an ammeter in the circuit indicates 10 amperes. A and B are also connected by another circuit containing a galvanometer of 5000 ohms resistance, the deflection of the needle of which indicates a current of .00002 ampere. What is the resistance of the wire AB?

Ans. .01 ohm.

27. The positive poles A and B of a Grove and a Daniell cell are joined by a wire of 0.3ω resistance, and the negative poles C and D by a wire of 0.5ω . What is the D.P. between the middle points of AB and CD?

Grove Cell : int. res. = 0.2ω , E.M.F. = 1.8 volt.

Daniell ,, : ,, = 0.4ω , ,, = 1.1 ,,

Ans. 1.5 volt.

28. A circuit is made up of (1) a battery with terminals A, B, its resistance being 3ω and its E.M.F. 2.7 volts, (2) a wire BC of 1.5ω resistance, (3) two wires in parallel CDF, CEF, with respective resistances 3ω and 7ω , (4) a wire FA of resistance 1.5ω . The middle point of the last wire is earthed. Find the potentials of the points A, B, C, F.

Ans. $-0.25, 1.45, 0.95, 0.25$.

29. Twelve wires of equal length and electric resistance are arranged to form the edges of a cube, and a current of 40 milli amperes is led into the cube at one corner and out at the opposite corner. Find the D.P. between these two corners and the effective resistance of the framework, the resistance of each wire being 6 ohms.

Ans. D.P. = 0.2 volts, R = 5 ohms.

30. 100 inches of copper wire weighing 100 grains has a resistance of 0.1516 ohm. Required the resistance of 50 inches weighing 200 grains.

Ans. 0.0379 .

31. A mile of nearly pure copper wire weighing one pound has a resistance of 1200 ohms at $15^{\circ}5$ C.; what is the resistance at the same temperature of a mile of the same quality of wire weighing 125 pounds?

Ans. 9.6 ohms.

32. The specific gravity of platinum is $2\frac{1}{2}$ times that of copper; its specific resistance $5\frac{5}{8}$ as great. What length of platinum wire weighing 100 gr. has the same resistance as 10 metres of copper wire also weighing 100 gr.?

Ans. 7.45 m.

33. A cell with a resistance of an ohm is connected by very short thick wires with the binding screws of a tangent galvanometer, the resistance of which is half an ohm, and the deflection is 45° ; if the screws of the galvanometer are also connected at the same time by a wire of 1 ohm resistance, find the deflection.

Ans. $36^{\circ}52'$.

34. The resistance of a tangent galvanometer is half an ohm, and the deflection when the current of a cell is passed through it is 30° . When a wire of 2 ohms resistance is introduced into the circuit the deflection is 15° ; find the internal resistance of the cell.

Ans. 1.23 ohm.

35. When the current of a cell, the resistance of which is $\frac{2}{3}$ of an ohm, is passed through a galvanometer connected with it by very short thick wires, the deflection is 45° ; when the binding screws are also connected by a shunt having a resistance of 1 the deflection is $33^{\circ}42'$. Find the resistance of the galvanometer.

Ans. 2 ohms.

35. A cell whose internal resistance is 2 ohms has its + pole connected with the binding screw A of a galvanometer formed of a thick band of copper. From the other screw B a wire of 20 ohms resistance passes to the - pole, and the deflection read off is $7^{\circ}8'$. Find the deflection when B is at the same time connected with the - pole by a second wire of 30 ohms resistance.

Ans. $11^{\circ}8'$.

37. A Leclanché cell deflects a tangent galvanometer 30° when 200 ohms resistance are introduced into the circuit, 15° when 570 ohms are introduced; a standard Daniell cell deflects it 30° when 100 ohms are in circuit, and 15° when 250 additional ohms are introduced. Required the electromotive force of the Leclanché in terms of that of the Daniell.

Ans. 1.48 .

38. A Bunsen and a Daniell cell are placed in the same circuit in the first case so that the carbon of the Bunsen is united to the zinc of the Daniell; and in the second case so that their E.M.F.s oppose each other. The deflections of a tangent galvanometer in the circuit are respectively $30^{\circ}2'$, and $10^{\circ}6'$. Required the electromotive force of the Bunsen in terms of the Daniell.

Ans. 1.89 .

39. A telegraph line constructed of copper wire, a kilometre of which weighs 30.5 kilogrammes, is to be replaced by iron wire a kilometre of which weighs 135.6 kilo-

grammes. In what ratio does the resistance alter? *Ans.* The resistance of the iron wire will be 1.18 times that of the copper wire for which it is substituted.

40. A telegraph line which has previously consisted of copper wire weighing 30.5 kilogrammes to the kilometre is to be replaced by an iron wire of the same length which shall offer the same resistance. What must be the section of the latter, and what its weight per kilometre?

Ans. The section of the copper wire is 3.4357 sq. mm., that of the iron by which it is replaced is 20.6 sq. mm., and its weight per kilometre is 160.4 kilogrammes.

41. When the poles of a voltaic cell are connected by a conductor of resistance 1, a current of strength 1.32 is produced; and when they are connected by a conductor of resistance 5 the strength of the current is 0.33. Find from these data the internal resistance and the electromotive force of the cell. *Ans.* $R = \frac{1}{3} E = 1.76$.

42. Two points 135° apart in a uniform circular conducting ring are connected with the opposite poles of a voltaic battery. Compare the strengths of the current in the two portions of the ring.

43. A mile of cable with a resistance of 3.59 ohms was put in water, with the end B insulated; its core having been pricked with a needle the resistance tested from the end A was found to be 2.81 ohms. A being insulated, a test from B showed the resistance to be 2.76. Required the distance from B to the injured spot.

Ans. 867 yards

44. A silver wire is joined end to end to an iron wire of the same length, but of double the diameter, and six times the specific resistance; the other ends are joined to the battery, the current of which is transmitted for five minutes, during which time a total quantity of 45 units of heat is generated in the two wires. How is it shared between them?

Ans. $Ag : Fe = 18 : 27$.

45. The poles of a battery are connected by two wires in parallel, whose resistances are 2ω and 3ω respectively, that of the battery being 1ω . Compare the amounts of heat developed in the two wires and in the battery in a given time.

Ans. $18 : 12 : 25$.

46. A current of 1 ampere flowing for one second through a resistance of 1ω produces 0.239 calories of heat. What current would have to flow for an hour through a resistance of 41.84ω in order that the heat produced might suffice to raise a kilogramme of water from 0° C. to the boiling-point?

Ans. 0.308 ampere.

47. A wire AB of 0.33ω resistance forms part of a circuit through which an electric current flows in direction from A to B. The points A and B are also connected by another conducting path, in which is included a cell of 1.287 volt and a galvanometer, the positive pole of the cell being joined to A. If the galvanometer needle is not deflected, what is the strength of the current in the wire AB?

Ans. 3.9 ampere.

48. A circuit is formed of 6 similar cells in series and a wire of 10ω resistance. The E.M.F. of each cell is 1 volt, and its internal resistance 0.5ω . Determine the D.P. between the positive and negative poles of any one of the cells.

Ans. 0.25 volt.

49. A circuit contains a battery (E.M.F. = 8 volts, res. = 3ω), a coil of wire ($r = 0.2\omega$), and a water voltmeter ($r = .5\omega$, back E.M.F. = 1.5 volt). Determine the current, the D.P. at the terminals of the battery, and the D.P. at the terminals of the voltmeter.

Ans. $c = 1.18$ ampere; $e_1 = 4.46$ volts; $e_2 = 2.09$ volts.

50. The centre of a circular coil of wire is on the same level as a compass needle, and the coil is moved round the needle in such a way that its centre is always the same distance from the centre of the needle, and its plane vertical and parallel to the magnetic meridian. Show that there are 4 positions of the coil in which a current traversing it will cause no deflection of the needle.

51. Two tangent galvanometers are similar in all respects except that in one a single coil is used, while in the other there are two coils (each of which is similar to that in the other instrument) close together. The instruments are joined up in parallel, and a current passed through them. What is the relation between the deflections of the needles?
Ans. The deflections are the same.

52. In a thermo-electric circuit consisting of iron and copper, if one junction is at 0° and the other at 100° , a strong current is produced; but if one junction is at 230° and the other at 330° there is little or no current. Explain this.

53. Two cells A and B (E.M.F. and internal resistance of each are 1 volt and 1ω respectively) are arranged in series. The positive and negative poles of this battery are connected with the positive and negative of a third cell C exactly like A and B, the connecting wires having negligible resistances. What is the current in the circuit, and what is the D.P. between the poles of the cell C?

Ans. Current = $\frac{1}{33}$ ampere; D.P. = 1.33 volt.

54. A compass needle is placed at the centre of two concentric circles which are in the same vertical plane, and are made of wires similar in all respects, except that the outer is copper, the inner German silver. The wires are connected in parallel, but so that the currents flowing through them circulate in opposite directions. What must be the ratio of the diameters of the circles that no effect may be produced on the needle? The specific resistances of copper and German silver are respectively 1.6 and 30 microhms per cm. cube.
Ans. Ratio = 4.33 : 1.

55. A battery of 20 secondary cells arranged in series, each cell having an E.M.F. of 2 volts, can maintain 10 lamps glowing. The lamps are in parallel, and each lamp requires an E.M.F. of 30 volts and a current of 0.5 ampere. What is the resistance of the cells?
Ans. 0.1 ω .

56. Six cells of equal E.M.F. and resistance are joined up in series with an external resistance which is half that of the battery. Show that the 6 cells may be joined up in three other ways, and give the same current as before.

57. If 1 ampere must be passed for 1609 minutes through acidulated water to evolve 1 gr. of hydrogen, for how long must 5 amperes be passed through a copper voltmeter that 1 gr. of copper may be deposited? Copper is divalent, and its atomic weight is 63.
Ans. $10^m 12.6$.

58. The atomic weight of hydrogen being 1, that of zinc 65, and that of copper 63.5, show what will be total quantity of zinc dissolved and of copper deposited in a Daniell's battery of 10 cells, while 2 decigrams of hydrogen are evolved in a voltmeter connected in circuit with the battery.
Ans. 6.5 gr. zinc, 6.35 gr. copper.

59. A tangent galvanometer is placed with its coil perpendicular to the magnetic meridian. When no current is passing through it the needle, on being set in vibration, oscillates 10 times in 15 seconds. Will the rate of vibration be altered when a current is passing through the coil, and if so will it be increased or diminished?

60. A wire the total resistance of which is 4ω is bent into the form of a square ABCD, the loose ends being soldered together. Find the resistance of the system when a current enters at B and leaves at D. Will it be modified if the corners A and C are connected by another wire?
Ans. 1 ω . No.

61. A wire is held in the magnetic meridian over a compass needle, and a current is passed through it of sufficient strength to deflect the needle through an angle which cannot be distinguished from a right angle. Show that when the needle is thus placed the current tends to lift it from its pivot.

62. Six similar cells are arranged in series, and a circuit completed through a coil of wire and a galvanometer. The resistances of the battery, coil, and galvanometer are 10, 50, and 20ω respectively. If the D.P. between the ends of the galvanometer is 2 volts, what is the E.M.F. of each cell of the battery?
Ans. 1.33 volt.

63. Three 16 candle-power and eight 30 candle-power lamps are placed in parallel across 110 volt mains. Taking the efficiency of each lamp as 3.5 watts per candle, find (a) the resistance of each lamp, (b) the current passing through each, (c) the total current passing, (d) the resistance between the mains.

Ans. (a) 216.1, 345.9 ohms.

(b) .509, .318 amp.

(c) 4.073 amp.

(d) 27 ohms.

64. A circular hoop of wire is hung by a fine wire in a vertical plane; another hoop, through which a current passes, is placed so that the straight line joining the centres of the two hoops is at right angles to their planes. Describe and explain the effect on the first hoop of suddenly turning the second hoop through 180° about a vertical axis.

65. A window casement of iron faces the south, and the hinges which support it are on the east. What electric phenomena are observed (a) when the window is opened, and (b) when it is closed?

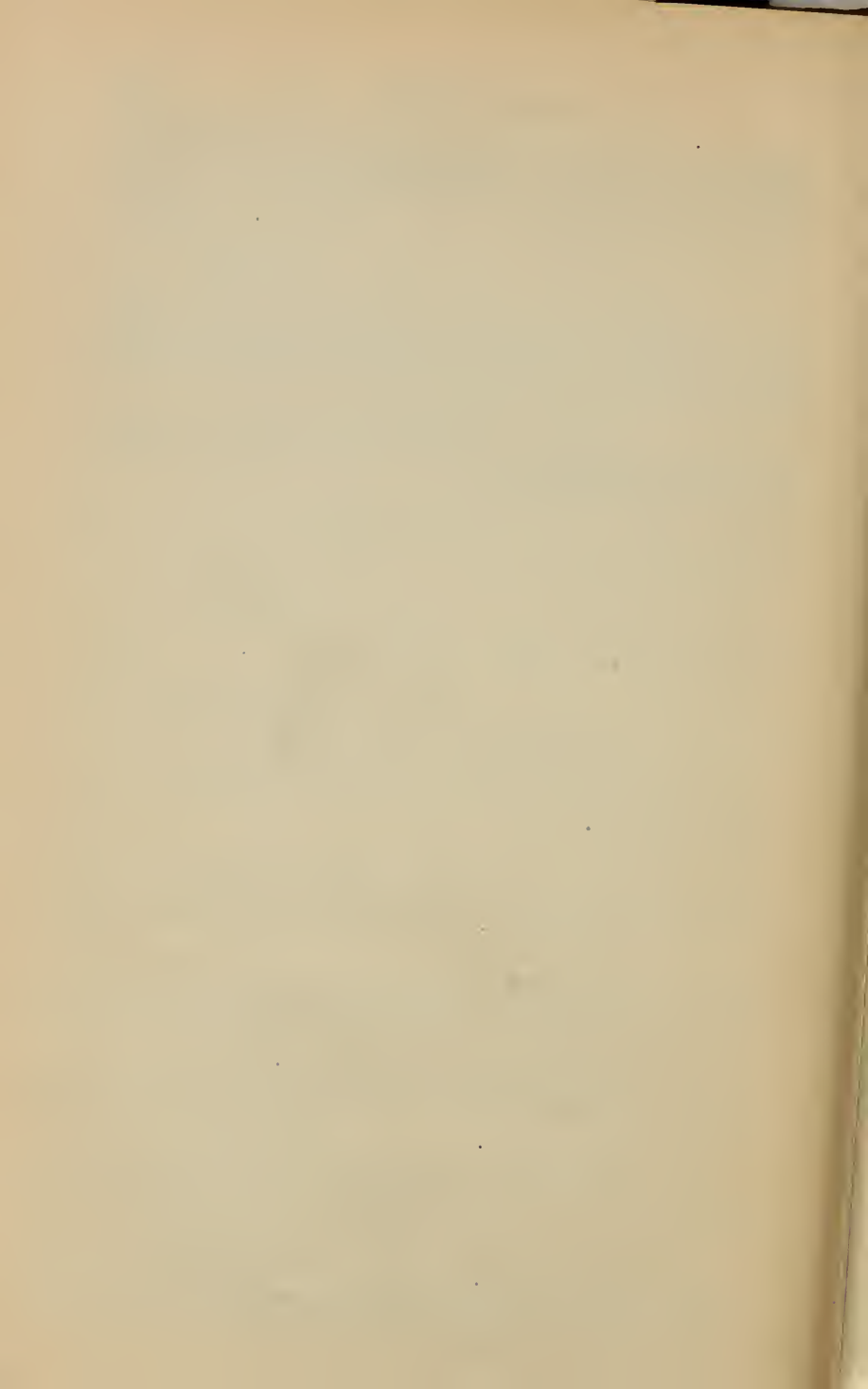

INDEX

(THE NUMBERS REFER TO THE ARTICLES)

- A**BERRATION, chromatic, 594 ;
 spherical, 542, 570
 Abnormal dispersion, 592
 Absolute expansion of mercury, 323
 Absolute, measure of temperature, 337,
 505 ; electric current, 837 ; E.M.F.,
 965 ; resistance, 970
 Absolute units, 63 ; electric, 1000
 Absorbent power of aqueous vapour, 1026
 Absorbing power, 428
 Absorption, electric, 789 ; of gases by
 solids, 194 ; of gases by liquids, 190 ;
 of heat by liquids, 439 ; by vapours,
 442 ; heat produced by, 489
 Acceleration, 32, 51, 61, 79
 Accidental, haloes, 641 ; images, 640
 Accommodation (of the eye), 634
 Accumulator, hydraulic, 107 ; electric,
 947
 Achromatism, 595
 Achromatopsy, 646
 Acierage, 956
 Aclinic line, 733
 Acoustic, foci, 238 ; attraction and repul-
 sion, 292
 Actinic, balance, 932 ; rays, 438, 584
 Action and reaction, 42
 Ader's telephone, 972
 Adhesion, 18
 Adiabatic lines, 507
 Aerial, meteors, 1014 ; perspective, 631 ;
 conductor, 1004
 Acrolites, 487
 Affinity, 17
 After action, elastic, 87
 Agonic lines, 728
 Air, aspirating action of currents of, 208 ;
 causes which modify temperature of,
 1015, 1046 ; heating by, 500 ; thermo-
 meter, 335 ; resistance of, 50 ; trap,
 169 ; gap, 977
 Air-balloons, 197 ; chamber, 218
 Air-brake, 212
 Air-pump, 201, 474 ; Bianchi's, 204
 condensing, 210 ; Fleuss, 205 ; gauges,
 202 ; rarefaction in, 201 ; receiver
 of, 201 ; Sprengel's, 206
 Ajutage, 146
 Alcarrazas, 376
 Alcohol thermometer, 307
 Alcoholic value of wines, 381
 Alcoholometer, 126
 Allotropic bodies, specific heat of, 463
 Alloys, melting point of, 343 ; specific
 resistance of, 850
 Alternating currents, 985
 Amagat's experiments, 96, 182
 Amalgam, electric, 769
 Amalgamated zinc, 819
 Amici's camera lucida, 615
 Ammeter, 989 ; Weston, 898 ; Evershed,
 903 ; Ayrton & Perry, 903
 Ampère, 831, 837, 849 ; turns, 902
 Ampère's *memoria technica*, 835 ; stand,
 888 ; theory of magnetism, 894
 Amplitude of vibration, 56, 253
 Analyser of polarised light, 670
 Analysis, spectral, 587 ; thermal, of
 solar light, 434
 Anamorphoses, 543
 Anelectrics, 742
 Anemometer, 1015
 Aneroid barometer, 188
 Angle, of deviation, 555 ; critical, 550 ;
 of polarisation, 668 ; of reflection and
 incidence, 522, 546 ; of refraction,
 546 ; visual, 630 ; of lead in dynamos,
 990
 Angular, currents, laws of, 882 ; velocity,
 55
 Animal heat, 494
 Anion, 934
 Annealing, 90, 93
 Annual variations of magnetic declination,
 729
 Anode, 934

(THE NUMBERS REFER TO THE ARTICLES)

- Antenna, 1004
 Anticyclone, 1020
 Antinode, 270
 Aperture, of mirror, 534; of lens, 570
 Aplanatic lenses, 570
 Aqueous humour of the eye, 625
 Aqueous vapour, its influence on climate, 1026; pressure of, 354-364
 Arago's experiment, 182, 963
 Arbor Dianæ, 949; Saturni, 949
 Arc, electric, 863
 Arc lamp, 864
 Archimedes' principle, 112; applied to gases, 196
 Armature, 709; Gramme ring, 989; drum, 992; Siemens', 987
 Armstrong's hydro-electric machine, 771
 Artesian wells, 110
 Artificial magnets, 694
 Ascent of liquids, in capillary tubes, 131; between plates, 132
 Aspirating action of air currents, 208
 Astatic, needles, 839; circuits, 892
 Astigmatism, 643
 Astronomical telescope, 606
 Athermancy, 439
 Atmolysis, 191
 Atmosphere, its composition, 159; crushing force of, 161; pressure of, 165; electricity in the, 1035; moisture of, 406
 Atmospheric, electricity, causes of, 1036, 1037; pressure, 158, 160, 165, 1015
 Atomic heat, 464
 Atoms, 3
 Attraction, capillary, 130; acoustic, 292; and repulsion produced by capillarity, 136; universal, 68
 Attraction, magnetic, laws of, 717; electric, laws of, 747, 753
 Atwood's machine, 79
 Audiometer, 974
 Audiphone, 240
 Aura, electric, 780
 Aurora borealis, 738, 1044
 Aurum musivum, 769
 Axis, optic, of crystal, 654, of mirror, 534, of lens, 562; of oscillation, 81
 Azimuth circle, 730
- B**AINE'S telegraph, 919
 Balance, 73; actinic, 932; beam of, 73; compensating, 321; delicacy of, 75; hydrostatic, 113, 122; induction, 974; knife-edge of, 73; physical and chemical, 75; spring, 87; torsion, 89, 718, 753
- Ballistic, galvanometer, 843; pendulum 83
 Balloons, 197-200; Montgolfier, 197 weight raised by, 200
 Barker's mill, 150
 Barlow's wheel, 889
 Barometers, 166; aneroid, 188; Bunten's, 169; cistern, 167; corrections in, 171, 172; determination of heights by, 179; differential, 187; Fortin's, 168; Gay-Lussac's, 169; glycerine, 178; precautions with, 170; wheel, 176; variations of height of, 173
 Barometric, formula, Laplace's, 179; gradients, 1020; height, corrected for temperature, 327; manometer, 187; variations, 174
 Baroscope, 196
 Battery, Bunsen's, 825; bichromate, 826; Clark's, 827; Daniell's, 822; floating, 888; gas, 945; gravity, 823; Grove's, 824; Leclanché's, 828; Leyden, 790; Minotto's, 823; secondary, 945; Smee's, 826; thermo-electric, 872; Wollaston's, 818
 Beats, 263
 Beaumé's hydrometer, 125
 Becquerel's pyrometer, 875; rays, 984
 Bell, of a trumpet, 239; electric, 910
 Bell's telephone, 971; photophone, 999
 Bellows, 243; hydrostatic, 100; water, 208
 Bells, 284
 Berthelot's calorimetric bomb, 492
 Berthollet's experiment, 189
 Bianchi's air-pump, 204
 Biaxial crystals, double refraction in, 658; rings in, 681
 Bichromate battery, 826
 Bi-compound engine, 477
 Bidwell's experiments, 906
 Binocular vision, 635
 Biot's apparatus, 691, 754
 Biquartz, 692
 Black's experiments on latent heat, 467
 Bladder, swimming, 116
 Blagden's law, 346
 Block and tackle, 44
 Blood-globules, 12
 Blue sky, 1027
 Bohnenberger's electroscope, 830
 Boiler, of steam engine, 473; water tube, 473A
 Boiling, 366; by cooling, 370
 Boiling-point, influence, of dissolved substances on, 368, of nature of vessel on, 369, of pressure on, 370; in a ther-

(THE NUMBERS REFER TO THE ARTICLES)

- mometer, 303 ; measurement of heights by, 372
 Bolometer, 932
 Bomb, calorimetric, 492
 Borda's method, 77
 Bottomley's experiment, 1031
 Boutigny's experiments, 390
 Boxes, resistance, 856
 Boyle's law, 181, 182
 Boys' radiomicrometer, 873 ; quartz threads, 89
 Brake, friction, 479 ; air, 210
 Bramah's hydraulic press, 107
 Breaking weight, 90
 Breezes, land and sea, 1018
 Breguet's thermometer, 310
 Bridge, Wheatstone's, 923
 British and French system of weights and measures, 26
 Brittle bodies, 92
 Brush discharge, 804
 Brushes, displacement of, 990
 Bulbs, specific gravity, 122
 Bunsen's, Sprengel-pump, 207 ; battery, 825 ; ice calorimeter, 456 ; photometer, 520
 Bunsen and Kirchhoff's researches, 584
 Buoyancy of liquids, 99
 Burning mirrors, 425

CABLE telegraph, 916
 Cagniard-Latour's, siren, 242 ; experiments on formation of vapour, 373
 Cailletet's and Pictet's researches, 385
 Calibration, 301
 Callan's battery, 825
 Callendar's platinum resistance thermometer, 932
 Calorescence, 438
 Calorie, 452
 Calorific effects, of electric discharge, 806 ; of electric current, 858 ; of the spectrum, 434, 584
 Calorimeter, Bunsen's ice, 456 ; Black's, 455 ; Favre and Silbermann's, 470 ; Lavoisier and Laplace's, 455 ; Regnault's, 459
 Calorimetry, 452
 Calotype process, 620
 Camera lucida, 615 ; Amici's, 615 ; Wollaston's, 615 ; camera obscura, 515, 614 ; photographic, 620
 Campani's eyepiece, 603
 Capacity, error of barometric, 167 ; electric, 760 ; specific inductive, 783 ; measurement of, 931 ; of accumulator, 947
 Capillarity, 130 ; attraction and repulsion produced by, 136 ; correction of barometric reading for, 171
 Capillary, phenomena, 130-138 ; electrometer, 950
 Carbonic acid, absorption of radiation by, 443
 Cardan's barometer suspension, 168
 Cardew's voltmeter, 867
 Carnot's cycle, 508 ; principle, 508
 Carré's mode of freezing, 377
 Cartesian diver, 115
 Cascade, charging by, 792
 Cathometer, 87
 Catoptric telescopes, 609
 Caustics, 542, 570
 Cauterisation, galvanic, 859
 Celsius' scale, 304
 Centesimal alcoholometer, 125
 Centigrade scale, 304
 Centre, optical, 566 ; of gravity, 70 ; of parallel forces, 41 ; of pressure, 101
 Centrifugal force, 55
 Centripetal force, 55
 C. G. S. System, 63
 Charge of a Leyden jar, penetration of, 789 ; measurement of, 793 ; residual, 789
 Charles's law, 332
 Chatterton's compound, 912
 Chemical, affinity, 17 ; equivalent, 940 ; heat due to chemical action, 491 ; action of current, 815, 933 ; harmonicon, 280 ; hygrometer, 399 ; properties of the spectrum, 584
 Children's experiment, 858
 Chimney, 497
 Chladni's experiments, 284
 Chlorophyl, 591
 Chords, major and minor, 248 ; physical constitution of, 265 ; vocal, 260
 Choroid, 625
 Chromatic scale, 250 ; aberration, 594
 Ciliary processes, 625
 Circle, azimuthal, 730
 Circular polarisation, 683
 Cirrocumulus and -stratus, 1022
 Cirrus, 1022
 Cistern barometer, 167
 Clamond's thermo-electric battery, 874
 Clarinet, 273
 Clark's cell, 827
 Clarke's magneto-electric machine, 986
 Cleavage, electricity produced by, 750

(THE NUMBERS REFER TO THE ARTICLES)

- Clément and Désormes' experiment, 208
 Climate, 1049; influence of aqueous vapour on, 1026
 Climatology, 1045-1052
 Clocks, 83; electric, 911
 Clouds, 1022; electricity of, 1037; formation of, 1023
 Coatings of Leyden jar, 786, 787
 Coefficient, of linear expansion, 317, 327; of conductivity, 411; Poisson's, 87; temperature, of resistance, 850
 Coercive force, 702, 740, 907
 Coherer, 1003
 Cohesion, 16
 Coil, primary and secondary, of induction, 957, 975; resistance, 856
 Cold, apparent reflection of, 425; produced by evaporation, 376, by expansion of gases, 506, by nocturnal radiation, 504; sources of, 502
 Colladon and Sturm's experiments, 234
 Collimation, line of, 606
 Collimator, 559
 Coloration produced by rotatory polarisation, 689
 Colour, 7; of bodies, 580; surface, 592; disc, 578; disease, 646
 Colours, contrast of, 641; mixed, 581; simple, 575; complementary, 581; produced by polarised light, 676-682; of thin plates, 664
 Combination notes, 264
 Combustion, 490; heat disengaged during, 491
 Comma, musical, 248
 Commutator, 986
 Compass, deviation of, 740; declination, 730; mariner's, 732; inclination, 734; prismatic, 732
 Compensation pendulum, 321
 Complementary colours, 581
 Component forces, 35
 Composition, of velocities, 54; of harmonic motions, 58, 59
 Compound, microscope, 602; wound dynamo, 991; bi- and tri-, engine, 477
 Compressed glass, colours produced by, 682
 Compressibility, 7, 19; of gases, 156, 182; of liquids, 96
 Concave mirrors, 425, 535
 Concert pitch, 251
 Condensation, of vapour, 380; method for specific heat, 461; of aqueous vapour, 1021, 1023
 Condensed gas, 194, 210
 Condenser, electric, 781, 799; of an engine, 474; limits to charge of, 783; of Ruhmkorff's coil, 976; Liebig's, 380
 Condensing, engine, 474; air-pump, 210; electroscope, 795; hygrometers, 400
 Conductance, 845
 Conduction, of heat, 410; of electricity, 743
 Conductivity, of solid bodies for heat, 410; coefficient of, 411; of liquids, 413; of gases, 414; specific electric, 845
 Conductors, 743; good and bad, 410; lightning, 1042
 Congelation, 346
 Conjugate mirrors, 425; focus, 535
 Connecting rod, 474
 Conservation of energy, 67
 Consonance, 255
 Constant cells, 821
 Contact theory of electricity, 815
 Contractile force, 320
 Convection, 414; currents, 449; electrolytic, 937
 Convective discharge, 786
 Convex mirror, 536, 538; lens, 562, 564
 Cooling, method of, 460; law of, 422
 Cornea, 625
 Cornet-à-piston, 282
 Corona, 1044
 Corpuscles, 982
 Corpuscular theory of light, 510
 Corti's fibres, 261
 Cosine, law of the, 420, 519
 Coulomb, 831, 1000
 Coulomb's law, 753; torsion balance, 718, 753
 Couple, 40; terrestrial magnetic, 726
 voltaic, 816; thermo-electric, 872
 Couronne des tasses, 818
 Cowper's writing telegraph, 921
 Crab winch, 45
 Crane, 45
 Critical, angle, 550; temperature, pressure, and volume, 373
 Crookes', radiometer, 449; vacuum, 206, 450; experiments, 981
 Cross-wires of a telescope, 606
 Crutch of a clock, 83
 Cryohydrate, 351
 Cyphorus, 376
 Crystallisation, 347
 Crystalloids, 140
 Crystals, 347; expansion of, 317; doubly refracting, 653; 673; uniaxial, 654; positive and negative, 657

(THE NUMBERS REFER TO THE ARTICLES)

- Cumulostratus clouds, 1022
 Cumulus clouds, 1022
 Current, unit of electric, 849
 Currents, action of, on currents, 880; motion of, in magnetic field, 885; action of earth on, 891; constant, 821; diaphragm, 951; direct and inverse, 957; extra, 967; strength of, 849; induction by, 957; laws of angular, 882; laws of sinuous, 883; local, 827; magnetisation by, 707, 901; muscular, 1007; rotation of magnets by, 887; earth, 1044; thermal effects of, 858
 Curves, magnetic, 700
 Cut-out, 859
 Cyclones, 1020
 Cylinder of steam engine, 474
 Cymbal, 284
- D**AGUERRETYPE, 620
 Daltonism, 646
 Dalton's, laws of gases and vapours, 388; method of determining the pressure of aqueous vapour, 359
 Damping, of strings, 281; of galvanometer needle, 843; of electric oscillations, 1004
 Daniell's, battery, 822; hygrometer, 401; pyrometer, 312
 Dark lines of the solar spectrum, 585, 590
 Davy's safety lamp, 410
 Dead-beat galvanometer, 843; dead-point, 476
 Declination, of a star, 611; magnetic, 727-730; variations in, 728; compass, 730
 Decomposition of water, 933; of white light, 574
 Decrement, logarithmic, 843
 De Forest's wireless telegraphy receiver, 1004
 De la Rive's floating battery, 888
 De la Rue and Müller's, battery, 826; experiments, 980
 Delezenne's circle, 966
 Densimeter, 129
 Density, 27; of an electric current, 953; of the earth, 69; electric, 755; of gases, 338-340; maximum of water, 331; of vapours, method, of Gay-Lussac, 391, of Dumas, 393, of Deville and Troost, 393, of Hofmann, 392
 Depression of liquids in capillary tube, 131; between surfaces, 132; of vapour pressure, molecular, 346
 Descartes' laws of refraction, 546
 Developer, 620
 Deviation, angle of, 555; minimum, 558; of compass, 740
 Deville and Troost's method, 393
 Dew, 1028; point, 400
 Diagram indicator, 479
 Dyalser, 140
 Dialysis, 140
 Diamagnetism, 701, 995
 Diaphanous bodies, 511
 Diaphragm, 602; currents, 951
 Diathermancy, 439
 Diatonic scale, 250
 Dielectric, polarisation, 770; constant, 783; strength, 784
 Dielectrics, 783
 Differential, barometer, 187; galvanometer, 842; lamp, 864; thermometer, 300; note, 264
 Diffraction, 514; fringes, 660; gratings, 661; spectra, 662
 Diffused light, 528
 Diffusion of liquids, 140; of gases, 191
 Diffusivity, 412
 Digester, Papin's, 374
 Dimensions of units, 63, 737, 758, 1000
 Dionæa muscipula, 1006
 Dioptric telescopes, 609
 Diosmose, 139
 Dip, magnetic, 733, 966; circle, 734
 Diphenylamine, 349
 Diplopia, 645
 Dipping needle, 734
 Direct vision spectroscope, 588
 Directive action of earth's magnetism, 726; on currents, 891, 892
 Disc, Newton's, 578; Maxwell's colour, 581
 Discharge, convective, 786; electric, effects of the, 800; spark and brush, 804; silent, 809; lateral, 1042
 Discharger, universal, 781
 Discharging rod, 732
 Dispersion, 555, 574; abnormal, 592
 Dispersive power, 577
 Displacement, of brushes, 990; electric, 1002
 Disruptive discharge, 800
 Dissipation of energy, 509
 Dissociation, 394, 493, 937
 Dissolving views, 616
 Distance, estimation of, 631; adaptation of eye to, 634
 Distillation, 380
 Distinct vision, distance of, 598

(THE NUMBERS REFER TO THE ARTICLES)

- Distribution, of free electricity, 754; of magnetism, 713; of temperature, 1050; of land and water, 1052
- Diurnal variations of magnetism, 729
- Diver, Cartesian, 115
- Divisibility, 7, 12
- Döbereiner's lamp, 489
- Dolbear's experiments, 971
- Dominant chords, 248
- Doppler's principle, 233, 590
- Double-image prism, 673
- Double refraction, 653, 666
- Double-weighing, 77
- Doublet, Wollaston's, 597
- Dove's law of storms, 1019
- Draught of fire-places, 497
- Drawplate, 91
- Dredging machines, 152
- Driving wheels, 477
- Drum, 285
- Drum armature, 992
- Drummond's light, 618
- Dry, batteries and piles, 829; plates, 622
- Duboscq's, microscope, 618; regulator, 864
- Ductility, 7, 91
- Duhamel's graphic method, 245
- Dulong and Arago's experiments on Boyle's law, 182; method of determining the tension of aqueous vapour, 360
- Dulong and Petit's, determination of absolute expansion of mercury, 323; method of cooling, 460; law, 464
- Dumas's method for vapour density, 393
- Duplex telegraphy, 918
- Duration of electric spark, 810
- Dutroche's endosmometer, 139
- Dynamical theory of heat, 433; of gases, 295
- Dynamo electric machine, 988, 991, 992
- Dynamometer, 88, 479; electro, 896, 899
- Dyne, 63
- E**AR, the, 261
- Ear trumpet, 239
- Earth, density of, 68; action of, on currents, 891; currents, 920, 1044; flattening of, by rotation, 84; magnetic poles of the, 733; magnetisation by the, 739
- Earth's magnetism, force of, 735
- Ebullition, 366
- Eccentric, 475
- Echelon lenses, 619
- Echoes, monosyllabic, trisyllabic, multiple, 237
- Eclipses, 514
- Eddy currents, 964
- Edelmann's hygrometer, 399
- Edison's, phonograph, 294; and Lalande's cell, 826
- Efficiency, of an accumulator, 847; of a machine, 153, 480; of a motor, 993; of heat engines, 482
- Effluvium, electric, 809
- Efflux, velocity of, 142; quantity of, 144; influence of tubes on, 145; through capillary tubes, 147
- Effusion of gases, 192
- Elastic after action, 87
- Elastic force of gases, 154; of vapours, 354
- Elasticity, 7, 20, 85-89
- Electric, arc, 853; batteries, 790; bell, 910; capacity, 760; conductivity, 743, 845; charge, 752; chimes, 779; clocks, 911; convection of heat, 879; current, 815; density, 755; egg, 805; endosmose, 951; field, 759; fish, 1012; furnace, 866; lamp, 865; light, 863; machines, 768, 776; pendulum, 747; pliability, 1002; potential, 757; pyrometer, 875; residue, 786; resistance, 850, 923, 970; resistance thermometer, 932; shock, 802; spark, 778; telegraphs, 912-921; tension, 956; thermometer (Kinnersley), 806; whirl, 780
- Electricity, application of, to medicine, 1013; atmospheric, 1033-1042; contact theory of, 813; development of, by friction, 742, by pressure and cleavage, 750; distribution of, 754; disengagement of, in chemical actions, 814; mechanical effects of, 808; velocity of, 811; theories of, 746; work required for production of, 777; and light, 996
- Electrocapillary phenomena, 950
- Electrochemical equivalent, 940
- Electrodes, 934; polarisation of, 820; non-polarisable, 1007
- Electrodynamometer, 896, 899
- Electrogilding, 954
- Electrolysis, 933; laws of, 939
- Electrolyte, 934
- Electromagnetic, motors, 993; units, 1000; theory of light, 1002
- Electromagnets, 901
- Electrometallurgy, 953
- Electrometer, 748; Lane's, 793; quadrant, 796; Thomson's absolute, 797; capillary, 950

(THE NUMBERS REFER TO THE ARTICLES)

- Electromotive, series, 816; force, 848, determination of, 929; force of cells, 831, 929, 965
 Electron, 940
 Electrophorus, 772
 Electroplating, 954 956
 Electroscopes, 748; Bohnenberger's, 830; Volta's condensing, 795
 Electrostatic, units, 1000; pressure, 756; capacity, 760; induction, 762; voltmeter, 798
 Electrostriction, 808
 Elliptic polarisation, 683, 686
 Emission theory, 510
 Emissive power, 429
 Emmetropic eye, 643
 Emulsions, 140; gelatine, 622
 Endosmometer, 139
 Endosmose, 139; electric, 951; of gases, 191
 Endosmotic equivalent, 139
 Endothermic reactions, 493
 Energy, 64; conservation of, 67; dissipation of, 509; transformations of, 66; varieties of, 65
 Engines, gas, 482; steam, 474; low and high pressure, 477; locomotive, 476; fire, 220; horizontal, 474; work of, 480; hot air, 481; oil, 483
 Equator, magnetic, 733
 Equilibrium, of forces, 38; of floating bodies, 114; of heavy bodies, 70; of liquids, 103-106; mobile, of temperature, 421; neutral, 72; stable, 72; unstable, 72
 Equipotential surfaces, 759
 Equivalent, electrochemical, 840; endosmotic, 139; mechanical, of heat, 506
 Erg, 63
 Escapement, 83; wheel, 83
 Ether, 433; luminiferous, 510
 Eustachian tube, 261
 Evaporation, 352; causes which accelerate, 365; cold due to, 376; latent heat of, 375
 Evaporation and ebullition, 365
 Ewing's experiments, 715
 Exchanges, theory of, 421
 Exhaustion, produced by air-pump, 202; by Sprengel's pump, 206
 Exosmose, 139
 Exothermic reactions, 493
 Expansibility of gases, 155
 Expansion, by heat, 298; of solids, 314-321; of liquids, 322 331; of gases, 332 - 335; coefficients of, 317; measurement of linear, 315, 316; force of, 320
 Expansion of gases, cold produced by, 503
 Expansive force of water in freezing, 349
 Experiment, Berthollet's, 189; Franklin's, 371; Florentine, 96; Pascal's, 164; Torricellian, 163
 Extension, 7, 9; of liquids, 96
 Extra current, 967
 Eye, 625; accommodation of, 634; not achromatic, 642; refractive indices of media of, 626; path of rays in, 628; dimensions of various parts of, 627; glasses, 644
 Eye lens, 603; Campani's, Huyghens', Ramsden's, 603
FAHRENHEIT'S hydrometer, 122; thermometer scale, 304
 Falling bodies, laws of, 78
 Falsetto notes, 263
 Farad, 931
 Faraday's, ice-pail experiments, 764; chamber, 765; disc, 889, 965; theory of induction, 766; voltameter, 933; wheel, 639
 Fatigue, elastic, 87
 Favre and Silbermann's, calorimeter, 470; determination of heat of combustion, 491
 Feed-valve, 473
 Ferromagnetic substances, 701
 Fibres, Corti's, 261
 Field, electric, 759; magnetic, 699; of a microscope, 603; of view, 604
 Field lens, 603
 Field magnets, 986, 988
 Figures, Lichtenberg's, 788
 Filament of glow lamp, 865
 Filters, 15
 Finder, 606
 Fire-ball, 1038; -engine, 220; -places, 496
 Fish, electric, 1012
 Fishes, swimming bladder of, 116
 Fizeau's experiments, 317, 518
 Flag signals, 914
 Flame, 490; sensitive, 280
 Flask, specific gravity, 120, 122
 Flattening of the earth, 84
 Fleming's, rule, 960; cell, 817
 Fleuss pump, 205
 Flexure, elasticity of, 88
 Floating bodies, 114
 Florentine experiment, 13, 96
 Fluid, 4; imponderable, 6; elastic, 154; magnetic, 698

(THE NUMBERS REFER TO THE ARTICLES)

- Fluidity, 7
 Fluorescence, 593
 Flute, 282
 Flux, of magnetic force, 723; density, 902
 Fluxes, 343
 Focal length, determination of, of mirror, 539; of lens, 572
 Foci, acoustic, 237; conjugate, 425, 535, 584; magnetic, 735
 Focus, of concave mirror, 535; of convex mirror, 536; of lens, 563; of parabolic mirror, 544
 Focusing the microscope, 597, 602
 Fog-signal, 242
 Fogs, 1021
 Föhn, 1018
 Foot-pound, 61, 480
 Force, 29; centrifugal, 55; pump, 218; coercive, 702, 907; elastic, of gases, 154; lines of magnetic, 699; of expansion and contraction, 320; electro-motive, 831, 848; representation of, 29; of liquids, 330; portable, 710, 905
 Forces, 6; along the same line, 33; equilibrium of, 36; molecular, 85; moments of, 39; parallelogram of, 36; polygon of, 37; triangle of, 38
 Fortin's barometer, 168
 Foucault, currents, 964; determination of velocity of light, 517; experiment, 964
 Fountain, in vacuo, 211; intermittent, 213, at Giggleswick, 215; Hero's, 212
 Fovea centralis, 625
 Franklin's, experiment, 371, 1033; plate, 785; theory of electricity, 746
 Fraunhofer's lines, 585
 Free path, 296
 Freezing, apparatus for, 377
 Freezing, mixtures, 350; point in a thermometer, 303
 Fresnel's, experimentum crucis, 659; rhomb, 685
 Friction, 46, 49; heat of, 484; hydraulic, 146; internal, of liquids, 50, 147, and of gases, 450; development of electricity by, 742; brake, 479
 Friction wheels, 79
 Fringes, 659
 Frog, rheoscopic, 1009
 Frost, 1028
 Fulcrum, 43
 Fulgurites, 1040
 Fulminating pane, 785
 Furnace, electric, 866
 Fusing point, 341
 Fusion, laws of, 341; vitreous, 341; latent heat of, 467
 GALILEO'S telescope, 608
 Galleries, whispering, 237
 Galvani's experiment, 812
 Galvanometer, tangent, 837; sensitive, 839; astatic needle, 840; mirror, 841; ballistic, 843; dead-beat, 843; suspended coil, 896; differential, 842; sine, 838
 Galvanoplastics, 953
 Gas, battery, 945; engines, 482
 Gaseous state, 4
 Gases, absorption of, by liquids, 190, by solids, 194, by vapours, 440; application of Archimedes' principle to, 196; cold produced by expansion of, 503; occlusion of, 195; compressibility of, 156, 182; condensed, 194, 210; conductivity of, 415; diamagnetism of, 995; density of, 338; dynamical theory of, 295; expansion of, 155, 332; endosmose of, 191; effusion of, 192; transpiration of, 193; index of refraction of, 561; laws of mixture of, 189; permanent, 383; liquefaction of, 383; physical properties of, 154; pressure exerted by, 158; radiation of, 446; specific heat of, 466; velocity of sound in, 231; viscosity of, 450; weight of, 156
 Gauge, air-pump, 202; McLeod's, 206; rain, 1024
 Gauss' proof of inverse square law, 725
 Gay-Lussac's, alcoholometer, 126; barometer, 169; determination of the expansion of gases, 332; of vapour-density, 391; stopcock, 388
 Geissler's tubes, 206, 590, 979
 Geographical meridian, 727
 Geometrical shadows, 514
 Geryk pump, 205
 Giffard's injector, 208
 Gilding metal, 954
 Glacial pole, 1050
 Glaciers, 1032
 Glashier's, balloon ascents, 197; factors, 404
 Glass, compressed, 682; expansion of, 326; magnifying, 597; object, 601; opera, 608; unannealed, 682
 Glasses, weather, 176
 Globe lightning, 1038
 Glow, electric, 804; worm, 649; lamp, 865

(THE NUMBERS REFER TO THE ARTICLES)

- Glycerine barometer, 178
 Gold-leaf electroscope, 748
 Gong, 284
 Goniometers, 543
 Governor of a steam engine, 474
 Gradient, barometric, 1020
 Gramme, ring, 989; electric machine, 989
 Graphic method, Duhamel's, 245; Foster's, 861
 Graphophone, 293
 Gratings, 661
 Grave harmonic, 264
 Gravesand's ring, 298
 Gravitational density, 186
 Gravitation, 6, 84; terrestrial, 69, 84; accelerative effect of, 29; constant of, 29
 Gravity battery, 823
 Gravity, centre of, 70; determination of constant of, 77
 Gregorian telescope, 610
 Gridiron pendulum, 321
 Grimaldi's experiment, 659
 Grothüß's hypothesis, 937
 Grove's, battery, 824; gas battery, 945
 Growth of current in circuit, 969
 Guard ring, 797
 Guericke's, air-pump, 201; Magdeburg hemispheres, 162
 Guide-blades of a turbine, 151
 Guitar, 281
 Gulf Stream, 1047
 Guthrie's researches, 351
 Gymnotus, 1012
- H**AIL, 1030
 Hair hygrometer, 405
 Haldat's apparatus, 100
 Hall's experiment, 900
 Hallström's experiments, 331
 Haloes, 641, 660, 1022
 Hammer, oscillating, 975; of a piano, 281
 Hampson's apparatus, 387
 Harcourt's pentane lamp, 520
 Hardening, 90, 93
 Hardness, 7; scale of, 92
 Harmonic, triad, 248; grave, 264; motion, 57
 Harmonicon, chemical, 280
 Harmonics, 254, 275
 Harp, 281; Marloye's, 283
 Harris's unit jar, 794
 Heat, 294; animal, 494; absorption of, by vapour, &c., 440, 445; atomic, 464; conduction of, 409; dynamical theory of, 433; latent, 344; mechanical equivalent of, 506; polarisation of, 693; produced by absorption and imbibition, 489; of combination, 491; radiant, 417, 420; reflection of, 423; sources of, 484-494; specific, 453-466; transmission of, 409; terrestrial, 488; in electric circuit, 858
 Heating, 495; by steam, 499; by hot air, 500; by hot water, 501
 Hefner Alteneck, lamp, 520; regulator, 869
 Height of barometer, 167; variations in, 173
 Heights of places, determination of, by barometer, 179; by boiling point, 372
 Heliograph, 533
 Heliostat, 543
 Helmholtz's, analysis of sound, 256-259; galvanometer, 837
 Hemispheres, Magdeburg, 162
 Henley's electrometer, 748
 Henry, 968
 Herapath's salt, 672
 Hero's fountain, 212
 Heroult's electric furnace, 866
 Herschelian telescope, 612
 Hertz's experiments, 1003
 Hirn's experiments, 506
 Hoar-frost, 1028
 Hofmann's density of vapours, 392
 Holtz's electric machine, 775
 Homogeneous, light, 583; medium, 513
 Hope's experiments, 331
 Horizontal, line, 69; plane, 69; force of earth's magnetism, 736
 Horn, musical instrument, 282
 Horse-power, 63, 479
 Hot-air, engines, 481; heating by, 500
 Hotness, 299
 Hot-water, heating by, 501
 Hot-wire instruments, 867
 Howard's nomenclature of clouds, 1022
 Hughes's, microphone, 972; induction balance, 974
 Humours, aqueous and vitreous, of the eye, 625
 Huyghens' eyepiece, 603
 Hyaloid membrane, 625
 Hydraulic, press, 107; engine, 153; friction, 146; lift, 107; power, application of, 107; ram, 152; sourniquet, 150
 Hydro-electric machine, 771
 Hydrogen, liquefaction of, 387
 Hydrometers, 119-129
 Hydrostatic, bellows, 100; paradox, 102 balance, 119, 122

(THE NUMBERS REFER TO THE ARTICLES)

- Hygrometers, 398, 405; chemical, 399; condensing, 400; Daniell's, 401; wet-bulb, 404; Regnault's, 402; Dines', 403; absorption, 405
- Hygrometric, state, 397; substances, 396
- Hygroscope, 405
- Hypermetropia, 643
- Hypsometer, 372
- Hysteresis, 907
- I**CE, 1031; specific heat by fusion of, 455; Bunsen's ice calorimeter, 456; expansive force of, 349; machine, 593
- Iceland spar, 673
- Ice-pail experiments, 764
- Ideal, gas, 294; solution, 13
- Idioelectrics, 742
- Images, accidental, 640; conditions of distinctness of, 598; formation of, in concave mirrors, 535, in convex mirrors, 538, in plane mirrors, 525; multiple, 526; magnitude of, 540; produced by small apertures, 515; virtual and real, 525; inversion of, 629
- Imbibition, heat produced by, 489
- Impedance, 985
- Impenetrability, 7, 8
- Imponderable matter, 6
- Incandescent lamps, 865
- Inclination, magnetic, 733; compass, 734
- Inclined plane, 46; motion on, 52
- Index of refraction, 547; measurement of, in solids, 559; in liquids, 560; in gases, 561
- Indicator diagram, McInnes', 480
- Indices, refractive, table of, 561
- Induced currents, 957-969; general principles of, 960
- Inductance, 967
- Induction, balance, 974; by the earth, 966; of a current on itself, 967; electrostatic, 762; in telegraph cables, 916; Faraday's theory of, 766; by Leyden discharge, 962; by magnets, 959; magnetic, 700
- Inductive capacity, specific, 783
- Inductorium, 975
- Inertia, 7, 22; applications of, 23; moment of, 89A, 711, 736
- Influence, magnetic, 700; electrostatic, 762
- Ingenhaus's experiment, 410
- Injector, Giffard's, 208
- Insects, sounds produced by, 244
- Insolation, 650
- Instruments, optical, 596; polarising, 670; mouth, 272; reed, 273; stringed, 281; wind, 271
- Insulating, bodies, 744; stool, 778
- Insulators, 743
- Intensity, of light, 519; of magnetisation, 722; of reflected light, 529; of a musical note, 246; of radiant heat, 420; of sound, causes which influence, 227; magnetic, 720, 735; of terrestrial gravity, 84; of magnetisation, 904
- Interference, of light, 659; of sound, 262
- Intermittent, fountain, 213; springs, 215; siphon, 215
- Interrupter, of induction coil, 975; Wehnelt, 976; mercury, 1004
- Intervals, musical, 247
- Inversion, of images, 629; thermo-electric, 870
- Ionisation, 937
- Ions, 934, 943, 982
- Iris, 625
- Iron ships, magnetism of, 740
- Irradiation, 641
- Irregular reflection, 528
- Isobars, 1020
- Isochimeral line, 1048
- Isochronism, 56
- Isoclinic lines, 733
- Isodynamic lines, 735
- Isogeothermic lines, 1048
- Isogonic lines, 728
- Isothermal lines, 1048
- Isothermal, lines, 373; 412, 507, 1048; zone, 1048
- J**AR, Harris's unit, 794; Leyden, 786-794
- Jet, lateral, 143; height of, 144; form of, 149
- Jew's harp, 273
- Jolly's, spring balance, 87; determination of gravity, 77
- Joly's condensation method for specific heat, 461
- Jordan's glycerine barometer, 178
- Joule's, experiment on heat and work, 506; equivalent, 506; law, 860; electromagnet, 901
- Jupiter, 516
- Jurin's laws of capillarity, 131
- K**ALEIDOPHONE, 639
- Kaleidoscope, 526
- Kamsin, 1018

(THE NUMBERS REFER TO THE ARTICLES)

- Kater's pendulum, 81
 Kathode, 934 ; rays, 981
 Kation, 934
 Keepers, 709
 Kelvin, Lord (*see* Thomson)
 Kerr's electro-optical experiments, 997
 Keynote, 249
 Kienmayer's amalgam, 769
 Kilogramme, 62, 479
 Kilowatt, 860
 Kinematograph, 639
 Kinetic energy, 64, 506
 Kinnersley's thermometer, 808
 Kirchhoff's laws, 855
 Knife-edge, 73
 König's, apparatus, 257 ; manometric flames, 290
 Kundt's velocity of sound, 279
- L** ABYRINTH of the ear, 261
 Lactometer, 128
 Lag, magnetic, 907
 Lalande and Chaperon's cell, 826
 Lambert's method, 581
 Lamp, incandescent, 865 ; Döbereiner, 489 ; differential, 864 ; safety, 410
 Land and water, distribution of, 1052
 Lane's electrometer, 793
 Langley's, observations on the spectrum, 436 ; bolometer, 932
 Lantern, magic, 616
 Laplace's barometric formula, 179
 Laryngoscope, 573
 Larynx, 260
 Latent heat, 344 ; of fusion, 467 ; of vapours, 375, 468
 Lateral jet, 143
 Latitude, magnetic, 733 ; influence of, on the temperature of the air, 1050 ; parallel of, 84
 Lavoisier and Laplace's calorimeter, 455 ; method of determining linear expansion, 315
 Lead, angle of, 990
 Lead tree, 949
 Lechatellier's thermo-junction, 875
 Lecher's method, 1003
 Leclanché's cell, 828
 Ledger lines, 252
 Leidenfrost's phenomenon, 390
 Lenard rays, 981
 Lens, axis of, 562 ; optical centre of, secondary axis of, 566
 Lenses, 562-572 ; formulae for, 563 ; achromatic, 595 ; aplanatic, 570 ; combination of, 571 ; in echelon, 619 ; images in double convex, 564, in double concave, 565 ; lighthouse, 619
 Lenz's law, 961
 Leslie's, cube, 427 ; experiment, 376 ; thermometer, 309
 Level, water, 108 ; spirit, 109
 Level surface, 69
 Lever, 43
 Leyden discharge, inductive action of, 962
 Leyden jars, 786-794 ; potential and capacity of, 799 ; work by, 801
 Lichtenberg's figures, 788
 Liebig's condenser, 380
 Lift, hydraulic, 107
 Ligament, suspensory, 625
 Light, 510 ; diffraction of, 660 ; homogeneous, 583 ; intensity of, 519 ; interference of, 659 ; laws of reflection of, 522 ; oxyhydrogen, 618 ; polarisation of, 666 ; change of intensity with distance of, 519, 522 ; sources of, 648 ; theory of polarised, 675 ; undulatory theory of, 510, 651 ; velocity of, 516-518
 Lighthouse lenses, 619
 Lighting, electric, 864
 Lightning, 1038 ; effects of, 1040 ; conductor, 1042
 Limit, of elasticity, 20 ; of perceptible sounds, 244 ; of magnetisation, 894
 Linde's, ice-machine, 503 ; apparatus, 387
 Line, aclinic, 733 ; of collimation, 606
 isoclinic, 733 ; agonic, 728 ; isogonic, 728 ; isodynamic, 735 ; of sight, 606
 Linear, expansion, coefficients of, 317 ; thermopile, 435
 Lines, of magnetic force, 699 ; of electric force, 759
 Lippmann's, capillary electrometer, 950 ; colour photography, 624
 Liquefaction, of gases, 383 ; of vapours, 378
 Liquids, 95 ; buoyancy of, 99 ; compressibility of, 96 ; conductivity of, 413 ; calculation of density of, 120 ; diffusion of, 140 ; diamagnetism of, 995 ; expansion of, 322 ; equilibrium of, 103 ; manner in which they are heated, 414 ; pressure of, on sides of vessel, 101 ; refraction of, 560 ; rotatory power of, 691 ; spheroidal form of, 16 ; spheroidal state of, 390 ; specific heat of, 463 ; volatile and fixed, 352 ; tensions of vapours of, 362 ; of mixed liquids, 363
 Lissajous's experiments, 286-288

(THE NUMBERS REFER TO THE ARTICLES)

- Local, action, 819; battery, 914
 Locatelli's lamp, 432
 Locomotives, 476
 Lodestone, 694
 Lodge's wireless telegraph receiver, 1004
 Longitudinal elasticity, 87
 Long sight, 643
 Loops and nodes, 270
 Loss of weight in air, correction for, 408
 Loudness of a musical tone, 246
 Lullin's experiment, 808
 Luminiferous ether, 510
 Luminous, bodies, 511; heat, 440; meteors, 1014; paint, 649; pencil, 512; radiation, 437; ray, 512
- M**ACHINE, Atwood's, 79; electric, 768-776
 Mackerel-sky, 1022
 Macleod's gauge, 206
 Magdeburg hemispheres, 162
 Magic lantern, 616
 Magnetic, attraction and repulsion, 696; battery, 708; circuit, 902; curves, 700; declination, 727; dip, 733; elements, 727; equator, 733; field, 699, 834, 836; flux density, 721; foci, 735; force, laws of, 717; force due to bar magnet, 723; induction, 700, 902; influence, 700; moment, 720, 724; intensity, 721; meridian, 726; needle, 694; observatories, 738; poles, 716, 733; reluctance, 902; saturation, 698; storms, 728, 738; substances, 701; detector, 1004
 Magnetisation, 703; by the action of the earth, 739; by currents, 707, 904; curve, 904; intensity of, 904; by single, separate, and double touch, 704-706; limit of, 894
 Magnetism, 6, 694; earth's, 726; of iron ships, 740; Ampère's theory of, 894; remanent, 904; theory of, 698; terrestrial, 726; distribution of free, 713; effect of temperature on, 712
 Magneto and dynamo-electric machines, 985-992
 Magnetometer method, 904
 Magnetomotive force, 902
 Magnets, artificial and natural, 694; broken, 697; action of earth on, 726; Meyer's floating, 714; heat developed by, 964; north and south poles of, 695; portable force of, 710; saturation of, 698; effect of temperature on, 712; induction by, 959; inductive action of, on moving bodies, 963; action of, on currents, 889, on solenoids, 893; optical effects of, 996
 Magnification, 540, 569; linear and superficial measure of, 600
 Magnifying, glass, 597; power, 605, of a telescope, 606
 Magnitude, 9; apparent, of an object, 599; of images in mirrors, 540
 Major, chord, 247; triads, 248
 Malleability, 7, 91
 Mance's, heliograph, 533; method, 927
 Manganese, magnetic limit of, 711; magnetic effect of, in alloys, 701
 Manhole, 473
 Manometer, 96, 184; with compressed air, 185; Regnault's barometric, 187
 Manometric flames, 290
 Mares' tails, 1022
 Marine, barometer, 169; engines, 474
 Mariner's, card, 1016; compass, 732
 Mariotte and Boyle's law, 181
 Mariotte's tube, 181
 Marloye's harp, 283
 Marsh gas, absorption of radiation by, 443
 Mascart's insulator, 744
 Maskelyne's experiment, 69
 Mason's hygrometer, 404
 Mass, measure of, 26; unit of, 26
 Matter, 2
 Matteucci's experiments, 766, 962
 Matthiessen's thermometer, 309
 Maximum and minimum thermometers, 311
 Maximum current, conditions of, 847
 Maxwell's, electromagnetic theory of light, 1002; colour discs, 581; rule, 960; law, 1002
 Mayer's floating magnets, 714
 Mean temperature, 1045
 Measure of force, 29; of work, 61
 Measure of magnification, 600; of mass, 26; of space, 25; of time, 24; of velocity, 28
 Measurement of small angles by reflection, 530
 Mechanical, equivalent of heat, 506; effects of electric discharge, 808
 Megavolt, 848
 Meloni's researches, 424
 Melting point, influence of pressure on, 342
 Membranes, semipermeable, 139; sensitive, 229; vibrations of, 285
 Meniscus, 130; convex and concave, 130; in barometer, 171
 Mensbrugghe's experiment, 133

(THE NUMBERS REFER TO THE ARTICLES)

- Mercury, frozen, 376, 384, 390; pendulum, 321; expansion of, 322; pump, 209; purification of, 169
- Meridian, 25; geographical and magnetic, 726
- Metacentre, 114
- Metal, Rose's and Wood's fusible, 341
- Meteoric stones, 487
- Meteorograph, 1015
- Meteorology, 1014
- Meteors, aerial, 1014
- Metre wire bridge, 923
- Metronome, 83
- Meyer's method for vapour density, 393
- Mho, 845
- Microfarad, 931
- Micrometer, 625; screw, 11
- Microphone, 972
- Microscope, simple, 597; Duboscq's, 618; compound, 601; field of, 604; focusing, 598; magnifying powers of, 600; photo-electric, 618; solar, 617
- Microspectroscope, 591
- Microvolt, 848
- Migration of the ions, 943
- Mill, Barker's, 150
- Milliammeter, 898
- Milliampère, 849
- Mineral waters, 1051
- Minimum, thermometer, 311; deviation, 558
- Minor chord, 248
- Minotto's battery, 823
- Mirage, 551
- Mirrors, 523; applications of, 543; burning, 425; concave, 424, 535, 537; conjugate, 425; convex, 536; parabolic, 544; rotating, 530, 810; spherical, 534
- Mists, 1021
- Mixture, of gases, 189; of gases and liquids, 190; laws of, 388
- Mixtures, freezing, 350; method of, 457
- Mobile equilibrium, 421
- Mobility, 7, 21
- Modulus, Young's, 87
- Moisture of the atmosphere, 406
- Molecular forces, 3; sieve, 139; state of bodies, 4; state, relation of absorption to, 450; velocity, 296
- Molecules, 3
- Moment, of forces, 39; of magnet, 720; comparison of moments, 724; of inertia, 89a, 711, 736
- Momentum, 31
- Monochord, 267
- Monochromatic light, 583
- Monosyllabic echo, 237
- Monsoon, 1018
- Montgolfier's, balloon, 197; ram, 152
- Moon, light of, 521
- Morin's apparatus, 80
- Morren's mercury pump, 209
- Morse's, telegraph, 914; key, 914
- Moser's images, 194
- Motion, 21; on an inclined plane, 50; laws of, 32; in a circle, 55; resistance to, in a fluid, 50; uniformly accelerated, 51; of a pendulum, 56; of a projectile, 53
- Motor, electric, 993
- Multiple, echoes, 237; images formed by mirrors, 526, 549
- Muscular currents, 1007
- Musical, boxes, 283; comma, 248; intervals, 247; scale, 248; temperament, 250; note, properties of, 246; intensity, 246; notation, 252; pitch and timbre, 246; range, 252
- Mutual induction, 968
- Myopia, 643
- N**ASCENT state, 17
- Natterer's apparatus, 384
- Natural magnets, 694
- Needle, declination, 728; dipping, 734; astatic, 839; magnetic, 695; thermo-electric, 875
- Negative plate, 816
- Negatives on glass, 621
- Nernst lamp, 865
- Nerve-currents, 1011
- Neumann's law, 465
- Neutral, region, 762; equilibrium, 72; temperature, 870
- Newton's, disc, 578; law of cooling, 422; rings, 664, 665; theory of light, 579
- Newtonian telescope, 611
- Niaudet's cell, 826
- Nicholson's hydrometer, 119
- Nickel, electric deposition of, 956
- Nicol's prism, 674
- Nimbus, 1022
- Robert's lines, 605
- Nobili's, rings, 948; thermo-electric pile, 873
- Nocturnal radiation, 504
- Nodal points, 270, 275, 650
- Nodes and loops, 270; of an organ pipe, 275; explanation of, 277
- Noises, 221
- Nonconductors, 743
- Non-polarisable electrodes, 1007
- Norremberg's apparatus, 671

(THE NUMBERS REFER TO THE ARTICLES)

- Northern light, 1044
 Norwegian stove, 416
 Notation, musical, 252
 Notes, in music, 246; musical, of women and boys, 260; wave-length of, 253
 Nut of a screw, 48
- O**BJECT-GLASS, 602, 606
 Objective, 602
 Oboe, 273
 Obscure, radiation, 437; rays, 438, transmutation of, 438
 Observatories, magnetic, 738
 Occlusion of gases, 195
 Occultation, 516
 Octave, 247
 Oersted's experiment, 835
 Ohm, 831
 Ohmmeter, 928
 Ohm's, law, 845; prism, 659
 Opaque bodies, 511
 Opera-glasses, 608
 Ophthalmoscope, 647
 Optic, axis, 630; axis of biaxial crystals, 658; angle, 630; nerve, 625
 Optical, centre, 566; effects of magnets, 996; instruments, 596
 Optometer, 632
 Orbit of the eye, 625
 Organ, 281; pipes, 275; nodes and loops of, 275
 Orthochromatic plates, 622
 Oscillating currents, 800, 1004, 1005
 Oscillation, 57; axis of, 81; method of, 719, 753
 Osmose, 139
 Osmotic pressure, 139
 Otto von Guericke's air-pump, 201
 Otto's gas engine, 483
 Overshot wheels, 151
 Oxyhydrogen light, 618
 Ozone, 809, 933, 1040
- P**ACINOTTI'S ring, 989
 Paddles of steam vessels, 151
 Paint, luminous, 650
 Pallet, 83
 Pandæan pipe, 282
 Pane, fulminating, 785
 Papin's digester, 374
 Parabolic, mirrors, 544; curve, 80, 143
 Parachute, 199
 Paradox, hydrostatic, 102
 Parallel, of latitude, 84; forces, 39, centre of, 39; rays, 512; cells in, 846; condensers in, 799
 Parallelogram of forces, 36
 Paramagnetic bodies, 701
 Pascal's law of equality of pressures, 97; experiments, 164
 Passage tint, 692
 Path, mean, of molecules, 296
 Pedal, 281
 Peltier's effect, 878
 Pelton's wheel, 151
 Pendulum, 56; application to clocks, 83; ballistic, 83; compensation, 321; electric, 742; length of compound, 81; reversible, 81; verification of laws of, 82
 Penetration of a telescope, 607
 Pentane lamp, 520
 Penumbra, 514
 Percussion, heat due to, 486
 Period of vibration, 56
 Permanent, gases, 383; magnetism, 904
 Permeability, magnetic, 721, 904
 Persistence of impression on the retina, 639
 Perspective, aerial, 631
 Phantasmagoria, 618
 Phase, 57, 287
 Phenakistoscope, 639
 Phonautograph, 289
 Phonograph, Edison's, 293
 Phosphorescence, 649
 Phosphorogenic rays, 584
 Phosphoroscope, 650
 Photo-electric microscope, 618
 Photo-electricity, 751
 Photogenic apparatus, 618
 Photography, 620-624
 Photometers, 520
 Photophone, 999
 Physical, phenomena, 5; agents, 6; properties of gases, 154; shadows, 514
 Physiological effects, of the electric discharge, 802; of the current, 1006; of Ruhmkorff's coil, 977
 Piano, 281
 Pictet's researches, 386
 Piezo-electricity, 751
 Piezometer, 96
 Pigment colours, 582
 Pile, voltaic, 818; thermo-electric, 873
 Pincette, tourmaline, 680
 Pipes, organ, 272
 Pisa, tower of, 70
 Pistol, electric, 809
 Piston, of air-pump, 201; rod, 474
 Pitch, concert, 251; of a note, 246; a screw, 48

(THE NUMBERS REFER TO THE ARTICLES)

- Plane, inclined, 46 ; mirrors, 523
 Planté's secondary battery, 946
 Plate electric machine, 768
 Plates, 553 ; colours of thin, 664 ; vibrations of, 284 ; Chladni's, 284 ; photographic dry, 622
 Pliability, electric, 1002
 Plumb line, 69
 Pluviometer, 1024
 Pneumatic syringe, 156, 486
 Point, boiling, 366
 Points, action of, 761, 780 ; nodal, 270
 Poisseuille's apparatus, 147
 Poisson's coefficient, 87
 Polar aurora, 1044
 Polarisation, of liquid, 944 ; E. M. F. of, 952 ; angle of, 668 ; current, 944 ; of electrodes, 820, 944 ; by double refraction, 666 ; by reflection, 667 ; by single refraction, 669 ; elliptic and circular, 683 ; of heat, 693 ; of light, 666 ; of the electric medium, 766 ; rotatory, 687 ; elliptic, 686
 Polarised light, theory of, 675 ; colours produced by the interference of, 676-682
 Polarising instruments, 670
 Pole, glacial, 1050
 Poles, of cell, 816 ; electric, 754 ; of the earth, 733 ; magnetic, 733 ; of a magnet, 695, 716 ; unit, 720 ; mutual action of, 696 ; red and blue, 696
 Polygon of forces, 7
 Polyorama, 618
 Polyprism, 555
 Pores, 13
 Porosity, 7, 13 ; application of, 15
 Portable force, 710, 905
 Positive plate, 816
 Postal battery, 914
 Potential difference, 757 ; measurement of, 925
 Potential energy, 64 ; of electricity, 757, 763 ; of a Leyden jar, 799
 Pound, avoirdupois, 26, 30 ; foot, 61
 Poudal, 30
 Power, 62 ; of a lens, 644 ; of a microscope, 604 ; of a machine, 860
 Presbyopia, 643
 Press, hydraulic, 107
 Pressure, centre of, 101 ; on a body in a liquid, 111 ; atmospheric, 163 ; amount of, on human body, 165 ; experiment illustrating, 211 ; influence on melting point, 342 ; heat produced by, 486 ; electric, 757 ; electricity produced by, 751 ; of light, 448
 Pressures, equality of, 97 ; vertical downward, 98 ; vertical upward, 99 ; independent of form of vessel, 100 ; on the sides of vessels, 101 ; capillary, 134 ; of vapour, 354
 Prévost's theory of exchanges, 421
 Primary coil, 957, 975
 Principle of Archimedes, 112
 Prism, 554 ; right angled, 556, 616 ; double refracting, 673 ; Nicol's, 674 ; with variable angle, 555 ; double image, 673
 Prismatic compass, 732
 Projectile, motion of, 53
 Prony's brake, 479
 Proof plane, 754
 Propagation of light, 513
 Protuberances, 590
 Psychrometer, 404, 1015
 Pulley, 44
 Pump, air, 201 ; condensing, 210 ; filter, 207 ; centrifugal, 151A
 Pumping engine, 474
 Pumps, different kinds of, 216 ; suction, 217 ; suction and force, 218
 Punctum cæcum, 625
 Pupil of the eye, 625
 Pyknometer, 120
 Pyroelectricity, 751
 Pyroheliometer, 487
 Pyrometers, 312 ; electric, 875, 932
- Q**UADRANT electrometer, 748, 796
 Quadrantal error of compass, 740
 Quality of musical note, 246
 Quantity, electric, 752, 930
 Quartz threads, 89
- R**ADIANT heat, 417 ; detection and measurement of, 418 ; causes which modify the intensity of, 420 ; Melloni's researches on, 432 ; relation of gases and vapours to, 443 ; relation of, to sound, 451
 Radiating power, 429 ; identity of absorbing and, 430 ; causes which modify, 431 ; of gases, 446
 Radiation, cold produced by, 504 ; of gases, 446 ; luminous, and obscure, 437 ; laws of, 437 ; solar, 487
 Radiative power of vapours, 1026
 Radioactivity, 982
 Radiometer, 449
 Radiomicrometer, 873
 Railway, friction on centrifugal, 55

(THE NUMBERS REFER TO THE ARTICLES)

- Rain, 1024 ; clouds, 1024 ; bow, 1043 ; fall, 1015, 1024, 1025 ; gauge, 1024 ; drop, velocity of, 50
- Ram, hydraulic, 152
- Ramsden's, electric machine, 768 ; eye-piece, 603
- Raoult's researches, 346
- Rarefaction, in air-pump, 202 ; by Sprengel's pump, 206
- Ray, incident, 546 ; luminous, 512 ; ordinary and extraordinary, 655
- Rays, actinic, or Ritteric, 438 ; divergent and convergent, 513 ; of heat, 417, 434 ; invisible, 433 ; obscure, 438 ; path of, in eye, 628 ; phosphorogenic, 584 ; polarised, 666 ; transmission of thermal, 439
- Reaction and action, 42
- Real image, 535, 564
- Réaumur scale, 304
- Receiver, of air-pump, 201 ; of electric waves, 1004
- Recomposition of white light, 578
- Reduction factor, 838, 841
- Reed instruments, 273
- Refining of copper, electric, 853
- Reflected light, intensity of, 529
- Reflecting, power, 427 ; goniometer, 543 ; sextant, 531 ; stereoscope, 637 ; telescope, 609
- Reflection, apparent, of cold, 428 ; laws of, 423 ; of heat, 423 ; from concave mirrors, 425 ; irregular, 528 ; in a vacuum, 427 ; of light, 522 ; total, 550 ; of sound, 236
- Refracting, stereoscope, 638 ; telescope, 606
- Refraction, 545-559 ; double, 653 ; polarisation by, 666, 669 ; explanation of single, 652 ; of sound, 238 ; constant of, 561 ; atomic, 561 ; molecular, 561
- Refractive index, 547 ; determination of, 559 ; of gases, 561 ; of liquids, 560 ; of solids, 561 ; indices of media of the eye, 626
- Refractory substances, 341
- Refrangibility of light, alteration of, 593
- Regelation, 1031
- Regnault's, experiments, 229 ; determination of density of gases, 334, 335 ; manometer, 187 ; methods of determining the expansion of gases, 334 ; of specific heat, 459 ; of pressure of aqueous vapour, 361 ; hygrometer, 402
- Regulator of the electric light, 864
- Regulus, 343
- Reis's telephone, 909
- Relay, 914
- Reluctance, magnetic, 902
- Remanent magnetism, 902
- Replenisher, 774
- Repulsion, laws of, magnetic, 718, electric, 753
- Residual, charge, 789 ; magnetism, 902
- Residue, electric, 789
- Resinous electricity, 745
- Resistance, limiting angle of, 46 ; of a fluid, 50 ; of a conductor, 743, 850 ; specific, 845, 850 ; influence of temperature on, 851 ; of a liquid, 852, 942 ; coils, 856 ; measurement of, 923 ; of galvanometer, 924 ; of a cell, 927 ; in absolute measure, 970
- Resistivity, 845
- Resonance, 255, 276 ; box, 251 ; globe, 256
- Resonator, electric, 1003
- Resultant of forces, 35-37
- Retardation, magnetic, 907
- Retina, 625 ; persistence of impression on, 639
- Return shock, 1041
- Reversible pendulum, 81
- Reversibility of Holtz's machine, 775
- Reversing gear of steam engine, 475
- Reversion spectroscope, 588
- Rheoscopic frog, 1009
- Rheostat, 857
- Rhomb, Fresnel's, 685
- Rhumbs, 732
- Riess's thermometer, 806
- Right ascension, 611
- Rigidity, simple, 89
- Rime, 1028
- Rings, coloured, 680 ; Gravesande's, 298 ; in biaxial crystals, 681 ; Newton's, 664, 665 ; Nobili's, 948
- Ritchie's, experiment, 430 ; telautograph, 921
- Ritteric rays, 438
- Robinson's anemometer, 1015
- Rock salt, heat transmitted through, 440
- Rods, vibrations of, 283
- Roget's vibrating spiral, 881
- Röntgen rays, 983
- Rose's fusible metal, 341
- Rotary engine, 478
- Rotating mirror, 517, 811
- Rotation, electrodynamic and electromagnetic, of liquids, 890 ; of winds, 1019
- Rotation, of the earth, 84 ; of magnets

(THE NUMBERS REFER TO THE ARTICLES)

- by currents, 887; of currents by magnets, 886, 889
- Rotatory polarisation, 687; of liquids, 691; coloration produced by, 689; due to magnetic field, 996
- Rousseau's densimeter, 129
- Roy and Ramsden's measurement of linear expansion, 316
- Rubbers of an electric machine, 768
- Ruhlmann's barometric and thermometric observations, 180
- Ruhmkorff's coil, 975; effects produced by, 977
- Rumford's photometer, 520
- Rutherford's thermometers, 311
- SACCHARIMETER**, 692
- Safety, catch, 859; tube, 382; valve, 107, 374, 473; lamp, 410
- Salimeters, 128
- Salts, decomposition of, by current, 935
- Saturation, degree of, 397; magnetic, 698, 904; of colours, 582
- Saussure's hygrometer, 405
- Savart's toothed wheel, 241
- Scale of hardness, 92
- Scales, in music, 248; chromatic, 250; of a thermometer, 304
- Scattered, heat, 428; light, 528
- Scheiner's experiment, 632
- Schiehallion experiment, 69
- Scintillation of stars, 551
- Sciopticon, 616
- Sclerotica, 625
- Scott's phonautograph, 289
- Scraping sound, 283
- Scratching sound, 283
- Screen, magnetic, 721
- Screw, 11, 48
- Scum valve, 473
- Search light, 543
- Secchi's meteorograph, 1015
- Secondary, axis of a lens, 566; batteries, 945; coil, 921; actions, 935
- Seconds pendulum, 81
- Secular magnetic variations, 728
- Segments, ventral and nodal, 270, 275
- Segner's water-wheel, 151
- Selenite, 678
- Selenium, 999
- Self-induction, 967; coefficient of, 968
- Semicircular error of compass, 740
- Semi-conductors, 743
- Semipermeable membranes, 139
- Semiprism, 587
- Semitones, 249
- Senarmont's experiment, 412
- Sensitive membrane, 229
- Serein, 1026
- Series and parallel, 799, 846
- Series, thermo-electric, 869; dynamo, 991
- Sextant, 531
- Shadows, 514
- Sharpness of sight, 633
- Shock, electric, 800; return, 1041
- Shooting stars, 487
- Short sight, 643
- Shunt, of galvanometer, 854; dynamo, 991
- Siemens', armature, 987; dynamo, 986, 992; electric thermometer, 995; electro-dynamometer, 896
- Sieve, molecular, 139
- Sight, long and short, 643
- Silent discharge, 809
- Silurus, 1012
- Silver voltameter, 941
- Simoom, 1018
- Simple, harmonic motion, 57; rigidity, 89; cell, 815
- Sine galvanometer, 838
- Sines, curve of, 59
- Singing of liquids, 366
- Sinuous currents, 883
- Sinusoidal currents, 985
- Siphon, 214; barometer, 169; recorder, 917; intermittent, 215
- Siren, 242
- Sirocco, 1018
- Six's thermometer, 311
- Size, estimation of, 631
- Sky, colour of, 1027
- Slect, 1029
- Slide valve, 474, 475
- Sling, 55
- Smee's battery, 826
- Snow, 1029; line, 1029
- Soap-bubble, colours of, 664
- Solar, constant, 487; microscope, 618; light, thermal analysis of, 434; radiation, 487; spectrum, 576, properties of the, 584, dark lines of, 585; time, 24; day, 24
- Soldering, 18
- Soleil's saccharimeter, 692
- Solenoid, 893
- Solidification, 346; change of volume on, 349; retardation of, 348
- Solidity, 4, 7
- Solids, conductivity of, 411; index of refraction in, 561; diamagnetism of, 995; linear and cubical expansion of, 317; surface tension of, 96
- Solids, formulæ of expansion, 319

(THE NUMBERS REFER TO THE ARTICLES)

- Solution, 345; ideal, 139
 Sondhauss's experiments, 238
 Sonometer, 267, 974
 Sound, 222; cause of, 223; not propagated in vacuo, 224; propagated in all elastic bodies, 225; propagation of, in air, 226; causes which influence intensity of, 227; apparatus to strengthen, 228; interference of, 262; velocity of, in air, 230, in gases, 231, in liquids, 234, in solids, 235; reflection of, 236; refraction of, 238; relation of radiant heat to, 451; transmission of, 228; waves, 229
 Sound, Helmholtz's analysis of, 256
 Sound, König's apparatus, 259; Kundt's, 279
 Sounder, 915
 Sounds, intensity of, 291; limit of perceptible, 244; synthesis of, 258; perceptions of, 261; produced by currents, 908
 Space, measure of, 25
 Spar, Iceland, 673
 Spark, and brush discharge, 804; electric, 778; duration and velocity of, 810, 811; gap, 977
 Sparking distance, 805, 832
 Speaking, trumpet, 239; tubes, 228
 Specific gravity, 27, 118-129; bottle, 120, 122; hydrometer, 119; of gases, 338; tables of, 121, 123
 Specific heat, 453-466; of liquids, 462; of gases, 466
 Specific, inductive capacity, 783; resistance, 845, 850
 Spectacles, 644
 Spectrometer, 559
 Spectroscope, 587; direct vision, 588; experiments with, 589; uses of the, 591
 Spectrum, 436; pure, 576; solar, 574; dark lines of, 585; diffraction, 662; properties of, 584; of aurora borealis, 1044; analysis, 586; colours and pigment, 582
 Specular reflection, 528
 Spherical aberration, 542, 570
 Spheroidal, form of liquids, 16; state, 390
 Spherometer, 11, 539
 Spiral, 901; Roget's vibrating, 881
 Spirit-level, 109
 Spray producer, 208
 Sprengel's air-pump, 206
 Spring balance, 87
 Springs, 1051; intermittent, 215
 Stable equilibrium, 72
 Standard cell, Daniell's, 821; L. Clark's, 827
 Stars, declination of, 612; spectral analysis of, 590
 Staubbach, 78
 Stave, 251
 Steam, heating by, 499
 Steam, engines, 472, work of, 479; boiler, 473; horn, 242; pipe, 208, 473
 Stealing, 956
 Stereometer, 186
 Stereoscopes, 636-638
 Stethoscope, 240
 Stills, 379
 Stool, insulating, 778
 Stopcock, doubly exhausting, 202; Gay-Lussac's, 388
 Stop valve, 473
 Storage batteries, 947
 Storms, magnetic, 738
 Stoves, 498; Norwegian, 416
 Stratification of electric light, 978
 Stratus clouds, 1022
 Strength, dielectric, 784
 Stretching of liquids, 96
 Striking distance, 805
 Stringed instruments, 281
 Strings, transverse vibration of, 266
 Stuffing-box, 477
 Subdominant chords, 248
 Substance, 2
 Suction pump, 217; and force pump, 218
 Sun, 521; analysis of radiation of, 435, 590
 Sun-spots, 738
 Superfusion, 348
 Surface, tension, 133-138; table of, 137; viscosity, 148
 Susceptibility, magnetic, 722
 Suspension, axis of, 73; Cardan's, 168
 Suspensory ligament, 625
 Swan lamps, 865
 Swimming, 117; bladder of fishes, 116
 Switch, 974
 Symmer's theory of electricity, 746
 Synthesis of sounds, 258
 Syringe, pneumatic, 156, 486

TAMTAM metal, 93
 Tangent galvanometer, 837
 Tapper, 1004
 Tears of wine, 134
 Telautograph, 921
 Telegraph, cables, 912; single needle, 913; Morse, 914; sounder, 915; writing, 921; Cowper's, 921; induction

(THE NUMBERS REFER TO THE ARTICLES)

- in, 916; electric, 912-921; electro-chemical, 919
- Telegraphone, 973
- Telegraphy, duplex, 918; without wires, 1004
- Telephone, 971; Reis's, 909; toy, 235
- Telescopes, 606; astronomical, 606; terrestrial, 607; Galileo's, 608; Gregorian, 610; Herschelian, 612; Newtonian, 611; reflecting, 609; notable, 613
- Telluric lines, 585
- Temperament, musical, 250
- Temperature, 299; correction for, in barometer, 172; critical, 373; determined by specific heat, 463
- Temperature, absolute zero of, 504, 508; influence of, on specific gravity, 123, on expansion, 319, on electric resistance, 851; mean, 1045; how modified, 1046; distribution of, 1050; of lakes, seas, and springs, 1051
- Temperatures, different remarkable, 313
- Tempering, 93
- Tenacity, 7, 90
- Tension, electric, 756; surface, 133
- Terrestrial, currents, 895, 920; heat, 488; magnetic couple, 726; magnetism, 726-736; telescope, 607
- Terrestrial gravitation, 69, 84
- Test objects, 605
- Thaumatrope, 639
- Theodolite, 10
- Theory, 5; of induction, 766
- Thermal, analysis of sunlight, 434; unit, 452, 493; springs, 1051
- Thermal, rays, transmission of, 439; unit, 452
- Thermobarometer, 372
- Thermo-dynamic efficiency, 481
- Thermo-electric, series, 869; inversion, 870; battery, 872, 874; pile, 418, 873; pyrometer, 875; diagram, 877
- Thermometer, 300; mercury, construction of, 302-304; displacement of zero of, 305; alcohol, 307; differential air, 309; metallic, 310; maximum and minimum, 311; correction of readings, 329; weight, 324; air, 335; Kinnersley's, 808; electric, 875, 932
- Thermoscope, 308
- Thin plates, colours of, 664
- Thomson effect, 879
- Thomson's, electrometers, 796, 797; galvanometer, 841; apparatus for atmospheric electricity, 1034; water-dropping collector, 773
- Thorium, radiation of, 982
- Thread of a screw, 48
- Threads, fine, 89
- Throw of a needle, 843
- Thunder, 1039
- Timbre, 246
- Time, measure of, 24; mean solar, 24; constant, 969
- Tint, 582; transition, 692
- Tones, combinational, 264; differential, 264
- Tonic, 248
- Toothed wheel, 241, 518
- Torpedo, 1012
- Toricelli's experiment, 163; theorem, 142; vacuum, 170
- Torsion, angle of, 89; balance, 89, 718, 753; moment of, 89
- Torsional elasticity, 89
- Total reflection, 550
- Tourmaline, 672, 751; pincette, 680
- Tourniquet, hydraulic, 150
- Tower of Pisa, 70
- Toy telephone, 235
- Trachea, 260
- Trajectory, 53
- Transformation of energy, 66
- Transformers, 994
- Transit, 24
- Transition tint, 692
- Translucent bodies, 511
- Transmission, of heat, 409; of light, 510, 553; of power by current, 994; of sound, 225
- Transparency, 7, 511
- Transpiration of gases, 193
- Triad, harmonic, 248
- Triangle, 283
- Triangle of forces, 38
- Tri-compound engine, 477
- Trumpet, speaking, ear, 239
- Tubes, Geissler's, 206, 979; safety, 382; speaking, 228
- Tuning-fork, 251, 283, 292
- Turbines, 151
- Twaddle's hydrometer, 125
- Twilight, 528
- Twinkling of stars, 551
- Tympanum, 261
- Tyndall's researches, 435, 451, 1027, 1032
- U**LTRAGASEOUS state, 981
- Unannealed glass, colours produced by, 682
- Undershot wheels, 151

(THE NUMBERS REFER TO THE ARTICLES)

- Undulation, length of, 226, 651
 Undulatory theory, 294, 510, 651
 Uniaxial crystals, 654; double refraction in, 658; positive and negative, 657
 Unit, Harris's, jar, 794; thermal, 452
 Unit of length, area and volume, 24; heat, 452; of work, 62
 Units, fundamental, 63; absolute electric, 1000
 Unstable equilibrium, 72
 Uranium, radiation of, 982
- V**ACUUM, application of air-pump to formation of, 201; extent of, produced by air-pump, 202; Crookes's, 450, 981; fall of bodies in a, 78; formation of vapour in, 354; heat radiated in, 419; reflection in a, 428; Torricellian, 170
 Valency, of an element, 940
 Valve, safety, 107, 374, 473; face, 474; slide, 475
 Van der Waals' formula, 183
 Vane, electric, 780
 Van 't Hoff's theory, 139, 937
 Vaporisation, 353; latent heat of, 375, 469
 Vapour, aqueous, pressure of, at various temperatures, 354-364; formation of, in closed tube, 373; latent heat of, 375; definition of, 373
 Vapours, 352; absorption of heat by, 440; absorptive powers of, 445; density of, Gay-Lussac's method, 391; Hofmann's, 392; densities of, 394; Dumas's method, 393; elastic force of, 354; formation of, in vacuo, 355; saturated, 356; unsaturated, 357; pressure of, of different liquids, 362; of mixed liquids, 363; in communicating vessels, 364
 Variations, magnetic, annual, 729, diurnal, 729; barometric, 173, causes of, 174, relation of, to weather, 175
 Velocities, composition of, 54
 Velocity, 28; of efflux, 142; of electricity, 811; of light, 516; graphic representation of changes of, 54; molecular, 296; of sound in air, 230, in gases, 231, 232, in liquids, 234, in solids, 235, Kundt's method of measuring, 279; of winds, 1015
 Vena contracta, 145
 Ventral segment, 270, 275
 Verdet's constant, 996
 Vernier, 10
 Vestibule of the ear, 261
 Vibrating spiral, Roget's, 881
 Vibration, 223; amplitude of, 56; produced by currents, 908; of tuning-forks, 283, 288
 Vibrations, 266; of membranes, 285; measurement of number of, 241; number of, producing any note, 251; of musical pipe, 277; of rods, 283; of plates, 284; of strings, 265
 Vierordt's quantitative spectrum analysis, 591
 View, field of, 604
 Vinometer, 381
 Violin, 281
 Virtual and real images, 525, 537
 Viscosity, 95, 147; of gases, 450
 Vision, distance of distinct, 633; binocular, 635
 Visual angle, 630
 Vital fluid, 812
 Vitreous, electric, 745; fusion, 341; humour, 625
 Vocal chords, 260
 Volatile liquids, 352
 Volt, 816, 831
 Volta's, condensing electroscope, 795; electrophorus, 772; fundamental experiment, 813
 Voltaic, arc, 863; cell, 816; pile, battery, 818; induction, 957
 Voltmeter, water, 933, 941; silver, 941; copper, 941
 Voltmeter, 925; electrostatic, 798; Cardew, 867; hot wire, 867
 Volume, unit of, 25; determination of, 113; change of, on solidification, 349; of a liquid and that of its vapour, relation between, 395; elasticity, 86
 Volumometer, 186
 Voss's electric machine, 775
- W**ATER, barometer, 177; bellows, 208; decomposition of, 933; hammer, 78; hot, heating by, 501; level, 109; maximum density of, 331; spouts, 1025; wheels, 151; gauge, 473
 Water-dropping collector, 773
 Watt, 860; wattmeter, 899
 Waves, 226; length of, 226, 651, 663; plane, 652; amplitude of oscillation in, 253

(THE NUMBERS REFER TO THE ARTICLES)

- Weather, its influence on barometric variations, 175; glasses, 176; charts, 1020; forecasts, 1020
- Wedge, 47
- Wedgwood's pyrometer, 312
- Wehnelt, interrupter, 976
- Weighing, method of double, 77
- Weight, 26; of bodies weighed in air, correction for loss of, 408; of gases, 157; thermometer, 325
- Wells's theory of dew, 1028
- Wells, artesian, 110
- Weston ammeter, 898
- Wet-bulb hygrometer, 404
- Wheatstone's, bridge, 923; method of comparing E.M.F.s, 929; photometer, 520; rotating mirror, 810; and Cooke's: telegraph, 913
- Wheel and axle, 45
- Wheel barometer, 176
- Wheels, friction, 79; escapement, 83; water, 151
- Whirl, electric, 780
- Whispering galleries, 237
- White light, decomposition of, 574; re-composition of, 578
- Wiedemann and Franz's tables of conductivity, 410
- Wimshurst's machine, 776
- Winch, 46
- Wind, chest, 273; instruments, 271, 282
- Wind pipe, 260
- Windhausen's ice machine, 503
- Winds, causes of, 1017; direction and velocity of, 1015, 1016; law of rotation of, 1019; periodical, regular, and variable, 1018
- Wine, alcoholic value of, 381; tears of, 134
- Wireless telegraphy, 1004
- Wollaston's, battery, 818; camera lucida, 615; cryophorus, 376; doublet, 597
- Wood, conductivity of, 410
- Wood's fusible metal, 341
- Work, 60; measure of, 61; of an engine, 480; rate of, 481; unit of, 62; internal and external, of bodies, 296
- Worthington's experiments on stretched liquids, 96
- Writing telegraphs, 921
- YELLOW** spot, 625
- Yoke, 901
- Young and Fresnel's experiment, 659
- Young's modulus, 88
- ZAMBONI'S** pile, 829
- Zeeman effect, 998
- Zero, absolute, 504; pressure of aqueous vapour below, 358; displacement of, 305
- Zigzag lightning, 1038
- Zinc, amalgamated, 819
- Zither, 281
- Zoetrope, 639
- Zone, isothermal, 1048





